



**THE DATASHEET OF
AD7732BRUZ**



FEATURES

High resolution ADC

- 24 bits no missing codes
- $\pm 0.0015\%$ nonlinearity

Optimized for fast channel switching

- 18-bit p-p resolution (21 bits effective) at 500 Hz
- 16-bit p-p resolution (19 bits effective) at 2 kHz
- 14-bit p-p resolution (18 bits effective) at 15 kHz

On-chip per channel system calibration

2 fully differential analog inputs

- Input ranges +5 V, ± 5 V, +10 V, ± 10 V
- Overvoltage tolerant
- Up to ± 16.5 V not affecting adjacent channel
- Up to ± 50 V absolute maximum

3-wire serial interface

- SPI™, QSPI™, MICROWIRE™, and DSP compatible
- Schmitt trigger on logic inputs

Single-supply operation

- 5 V analog supply
- 3 V or 5 V digital supply

Package: 28-lead TSSOP

APPLICATIONS

PLCs/DCS

Multiplexing applications

Process control

Industrial instrumentation

GENERAL DESCRIPTION

The AD7732 is a high precision, high throughput analog front end. True 16-bit p-p resolution is achievable with a total conversion time of 500 μ s (2 kHz channel switching), making it ideally suitable for high resolution multiplexing applications.

The part can be configured via a simple digital interface, which allows users to balance the noise performance against data throughput up to a 15.4 kHz.

The analog front end features two fully differential input channels with unipolar or true bipolar input ranges to ± 10 V while operating from a single +5 V analog supply. The part has an overrange and underrange detection capability and accepts an analog input overvoltage to ± 16.5 V without degrading the performance of the adjacent channels.

FUNCTIONAL BLOCK DIAGRAM

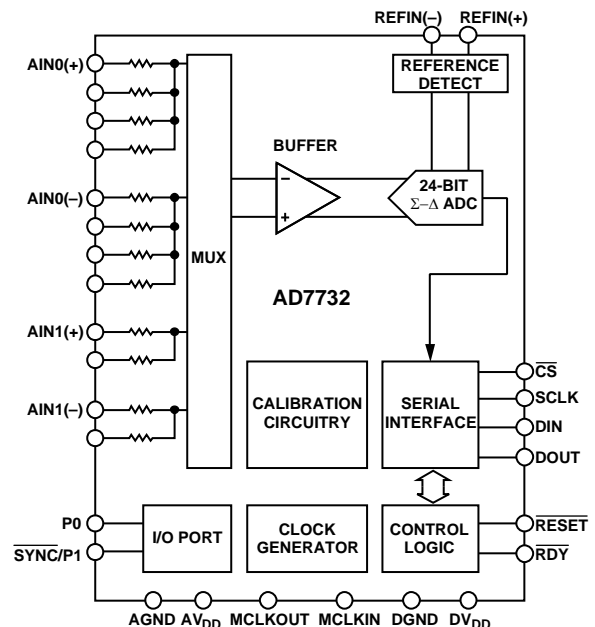

Figure 1.

The differential reference input features “No-Reference” detect capability. The ADC also supports per channel system calibration options. The digital serial interface can be configured for 3-wire operation and is compatible with microcontrollers and digital signal processors. All interface inputs are Schmitt triggered.

The part is specified for operation over the extended industrial temperature range of -40°C to $+105^{\circ}\text{C}$.

Other parts in the AD7732 family are the AD7734 and the AD7738.

The AD7734 is similar to AD7732, but its analog front end features four single-ended input channels.

The AD7738 analog front end is configurable for four fully differential or eight single-ended input channels, features 0.625 V to 2.5 V bipolar/unipolar input ranges, and accepts a common-mode input voltage from 200 mV to $\text{AV}_{\text{DD}} - 300$ mV. The AD7738 multiplexer output is pinned out externally, allowing the user to implement programmable gain or signal conditioning before being applied to the ADC.

Rev. A

Information furnished by Analog Devices is believed to be accurate and reliable. However, no responsibility is assumed by Analog Devices for its use, nor for any infringements of patents or other rights of third parties that may result from its use. Specifications subject to change without notice. No license is granted by implication or otherwise under any patent or patent rights of Analog Devices. Trademarks and registered trademarks are the property of their respective owners.

TABLE OF CONTENTS

AD7732—Specifications.....	3	Digital Interface Description	22
Timing Specifications.....	6	Hardware	22
Absolute Maximum Ratings.....	8	Reset	23
Typical Performance Characteristics	9	Access the AD7732 Registers.....	23
Output Noise and Resolution Specification.....	10	Single Conversion and Reading Data	23
Chopping Enabled.....	10	Dump Mode.....	24
Chopping Disabled.....	11	Continuous Conversion Mode	24
Pin Configurations and Functional Descriptions.....	12	Continuous Read (Continuous Conversion) Mode	25
Register Description.....	14	Circuit Description.....	26
Register Access.....	15	Analog Front End.....	26
Communications Register.....	15	Analog Input's Extended Voltage Range	27
I/O Port Register.....	16	Chopping.....	27
Revision Register	16	Multiplexer, Conversion, and Data Output Timing	28
Test Register	16	Sigma-Delta ADC	28
ADC Status Register.....	17	Frequency Response	28
Checksum Register.....	17	Voltage Reference Inputs.....	29
ADC Zero-Scale Calibration Register	17	Reference Detect.....	29
ADC Full-Scale Register.....	17	I/O Port.....	30
Channel Data Registers.....	17	Calibration.....	30
Channel Zero-Scale Calibration Registers	18	ADC Zero-Scale Self-Calibration	30
Channel Full-Scale Calibration Registers.....	18	Per Channel System Calibration	30
Channel Status Registers	18	High Common-Mode Voltage Application	31
Channel Setup Registers	19	Outline Dimensions	32
Channel Conversion Time Registers	19	Ordering Guide	32
Mode Register	20		

REVISION HISTORY

6/11—Rev. 0 to Rev. A

Changes to ADC Performance Chopping Enabled, Offset Error (Unipolar, Bipolar) Parameter, Offset Drift vs. Temperature Parameter, Positive Full-Scale Drift vs. Temp. Parameter, and Channel-to-Channel Isolation Parameter in Table 1	3
Change to ADC Performance Chopping Disabled, Channel-to-Channel Isolation Parameter in Table 1	3

Changes to Figure 22.....	25
Changes to Ordering Guide.....	32

2/03—Revision 0: Initial Version

AD7732—SPECIFICATIONS

Table 1. (–40°C to +105°C; AV_{DD} = 5 V ± 5%; DV_{DD} = 2.7 V to 3.6 V, or 5 V ± 5%; BIAS (all), REFIN(+) = 2.5 V; REFIN(–) = AGND; RA, RB, RC, RD open circuit; AIN Range = ±10 V; f_{MCLKIN} = 6.144 MHz; unless otherwise noted.)

Parameter	Min	Typ	Max	Unit	Test Conditions/Comments	
ADC PERFORMANCE						
CHOPPING ENABLED						
Conversion Time Rate	372		12190	Hz	Configure via Conv. Time Register FW ≥ 6 (Conversion Time ≥ 165 μs)	
No Missing Codes ^{1, 2}	24			Bits		
Output Noise		See Table 4			f _{MCLKIN} = 2.5 MHz, V _{CM} = 0 V f _{MCLKIN} = 6.144 MHz, V _{CM} = 0 V Before Calibration Before Calibration Before Calibration Before Calibration After Calibration At DC At DC, AIN = 7 V, AV _{DD} = 5 V ± 5% At DC, Maximum ±16.5 V AIN Voltage	
Resolution		See Table 5 and Table 6				
Integral Nonlinearity (INL) ^{1, 2, 3}		±0.0003	±0.0015	% of FSR		
Integral Nonlinearity (INL) ^{2, 3}		±0.0010	±0.0030	% of FSR		
Offset Error (Unipolar, Bipolar) ⁴			±13	mV		
Offset Drift vs. Temperature ¹		±2.5		μV/°C		
Gain Error ³			±0.7	%		
Gain Drift vs. Temperature ¹			±3.2	ppm of FS/°C		
Positive Full-Scale Error ⁴			±0.7	% of FSR		
Positive Full-Scale Drift vs. Temp. ¹		±3		ppm of FS/°C		
Bipolar Negative Full-Scale Error ⁵		±0.0060		% of FSR		
Common-Mode Rejection	50	65		dB		
Power Supply Sensitivity		±4	±10	LSB ₁₆		
Channel-to-Channel Isolation		110		dB		
ADC PERFORMANCE						
CHOPPING DISABLED						
Conversion Time Rate	737		15437	Hz	Configure via Conv. Time Register FW ≥ 8 (Conversion Time ≥ 117 μs)	
No Missing Codes ^{1, 2}	24			Bits		
Output Noise		See Table 7			% of FSR Before Calibration Before Calibration Before Calibration Before Calibration After Calibration At DC At DC, AIN = 7 V, AV _{DD} = 5 V ± 5% At DC, Maximum ±16.5 V AIN Voltage	
Resolution		See Table 8 and Table 9				
Integral Nonlinearity (INL) ^{2, 3}		±0.0015		% of FSR		
Offset Error (Unipolar, Bipolar) ⁶		±10		mV		
Offset Drift vs. Temperature		±25		μV/°C		
Gain Error ⁴		±0.5		%		
Gain Drift vs. Temperature		±5.3		ppm of FS/°C		
Positive Full-Scale Error ⁴		±0.5		% of FSR		
Positive Full-Scale Drift vs. Temp. ¹		±4		ppm of FS/°C		
Bipolar Negative Full-Scale Error ⁵		±0.0060		% of FSR		
Common-Mode Rejection		55		dB		
Power Supply Sensitivity		±4		LSB ₁₆		
Channel-to-Channel Isolation		110		dB		
ANALOG INPUTS						
Analog Input Differential Voltage ⁷						
±10 V Range		±10		V		
0 V to +10 V Range		0 to +10		V		
±5 V Range		±5		V		
0 V to +5 V Range		0 to +5		V		
AIN Absolute Voltage ^{1, 2, 8}	–16.5		+16.5	V		
BIAS Voltage ¹	0	2.5	AV _{DD}	V		
RA, RB, RC, RD Voltage ¹	–10.5		+20	V		
AIN Impedance ^{1, 9}	100	124		kΩ		
AIN Pin Impedance ^{1, 9}	87.5	108.5		kΩ		
BIAS Pin Impedance ^{1, 9}	12.5	15.5		kΩ		

AD7732

Parameter	Min	Typ	Max	Unit	Test Conditions/Comments
RA, RB, RC, RD Pin Impedance ^{1,9}	25	31		k Ω	
Input Resistor Matching		0.2		%	
Input Resistor Temp. Coefficient		-30		ppm/ $^{\circ}$ C	
REFERENCE INPUTS					
REFIN(+) to REFIN(-) Voltage ^{1,10}	2.475	2.5	2.525	V	NOREF Bit in Channel Status Register
NOREF Trigger Voltage		0.5		V	
REFIN(+), REFIN(-) Common-Mode Voltage ¹	0		AV_{DD}	V	
Reference Input DC Current ¹¹			400	μ A	
SYSTEM CALIBRATION^{1,12}					
Full-Scale Calibration Limit			$+1.05 \times FS$	V	
Zero-Scale Calibration Limit	$-1.05 \times FS$			V	
Input Span	$0.8 \times FS$		$2.1 \times FS$	V	
LOGIC INPUTS					
Input Current			± 1	μ A	$\overline{CS} = DV_{DD}$ $\overline{CS} = DGND$, Internal Pull-Up Resistor
Input Current \overline{CS}			± 10	μ A	
			-40	μ A	
Input Capacitance		5		pF	
V_{T+}^1	1.4		2	V	$DV_{DD} = 5 V$
V_{T-}^1	0.8		1.4	V	$DV_{DD} = 5 V$
$V_{T+} - V_{T-}^1$	0.3		0.85	V	$DV_{DD} = 5 V$
V_{T+}^1	0.95		2	V	$DV_{DD} = 3 V$
V_{T-}^1	0.4		1.1	V	$DV_{DD} = 3 V$
$V_{T+} - V_{T-}^1$	0.3		0.85	V	$DV_{DD} = 3 V$
MCLK IN ONLY					
Input Current			± 10	μ A	$DV_{DD} = 5 V$ $DV_{DD} = 5 V$ $DV_{DD} = 3 V$ $DV_{DD} = 3 V$
Input Capacitance		5		pF	
V_{INL} Input Low Voltage			0.8	V	
V_{INH} Input High Voltage	3.5			V	
V_{INL} Input Low Voltage			0.4	V	
V_{INH} Input High Voltage	2.5			V	
LOGIC OUTPUTS¹³					
V_{OL} Output Low Voltage			0.4	V	$I_{SINK} = 800 \mu A$, $DV_{DD} = 5 V$ $I_{SOURCE} = 200 \mu A$, $DV_{DD} = 5 V$ $I_{SINK} = 100 \mu A$, $DV_{DD} = 3 V$ $I_{SOURCE} = 100 \mu A$, $DV_{DD} = 3 V$
V_{OH} Output High Voltage	4.0			V	
V_{OL} Output Low Voltage			0.4	V	
V_{OH} Output High Voltage	$DV_{DD} - 0.6$			V	
Floating State Leakage Current			± 1	μ A	
Floating State Leakage Capacitance		3		pF	
P0, P1 INPUTS/OUTPUTS					
Input Current			± 10	μ A	Levels Referenced to Analog Supplies
V_{INL} Input Low Voltage			0.8	V	$AV_{DD} = 5 V$
V_{INH} Input High Voltage	3.5			V	$AV_{DD} = 5 V$
V_{OL} Output Low Voltage			0.4	V	$I_{SINK} = 7 mA$, See Abs. Max. Ratings
V_{OH} Output High Voltage	4.0			V	$I_{SOURCE} = 200 \mu A$, $AV_{DD} = 5 V$
POWER REQUIREMENTS					
AV_{DD} -AGND Voltage	4.75		5.25	V	$AV_{DD} = 5 V$ $DV_{DD} = 5 V$ $DV_{DD} = 3 V$
DV_{DD} -DGND Voltage	4.75		5.25	V	
	2.70		3.60	V	
AV_{DD} Current (Normal Mode)		13.5	15.9	mA	
DV_{DD} Current (Normal Mode) ¹⁴		2.8	3.1	mA	
DV_{DD} Current (Normal Mode) ¹⁴		1.0	1.5	mA	

Parameter	Min	Typ	Max	Unit	Test Conditions/Comments
Power Dissipation (Normal Mode) ¹⁴		85	100	mW	
AV _{DD} +DV _{DD} Current (Standby Mode) ¹⁵		140		μA	
Power Dissipation (Standby Mode) ¹⁵		750		μW	

¹ Specifications are not production tested but guaranteed by design and/or characterization data at initial product release.

² See Typical Performance Characteristics.

³ V_{CM} = Common-Mode Voltage = 0 V.

⁴ Specifications before calibration. Channel system calibration reduces these errors to the order of the noise.

⁵ Applies after the zero-scale and full-scale calibration. The negative full-scale error represents the remaining error after removing the offset and gain error.

⁶ ADC zero-scale self-calibration reduces this error to ±10 mV. Channel zero-scale system calibration reduces this error to the order of the noise.

⁷ For specified performance. The output data span corresponds to the specified nominal input voltage range. The ADC is functional outside the nominal input voltage range, but the performance might degrade. Outside the nominal input voltage range, the OVR bit in the channel status register is set and the channel data register value depends on the CLAMP bit in the mode register. See the register and circuit descriptions for more details.

⁸ The AIN absolute voltage of ±16.5 V applies for a nominal VBIAS voltage of +2.5 V. By configuring the BIAS and RA to RD pins differently, the part will work with higher AIN absolute voltages as long as the internal voltage seen by the multiplexer and the input buffer is within 200 mV to AV_{DD} - 300 mV. Absolute voltage for the AIN, BIAS, and RA to RD pins must never exceed the values specified in the Absolute Maximum Ratings.

⁹ Pin impedance is from the pin to the internal node. In normal circuit configuration, the analog input total impedance is typically 108.5 kΩ + 15.5 kΩ = 124 kΩ.

¹⁰ For specified performance. Part is functional with lower V_{REF}.

¹¹ Dynamic current charging the sigma-delta modulator input switching capacitor.

¹² Outside the specified calibration range, calibration is possible but the performance may degrade.

¹³ These logic output levels apply to the MCLK OUT output when it is loaded with a single CMOS load.

¹⁴ With external MCLK, MCLKOUT is disabled (the CLKDIS bit is set in the mode register).

¹⁵ External MCLKIN = 0 V or DV_{DD}, Digital Inputs = 0 V or DV_{DD}, and P0 and P1 = 0 V or AV_{DD}.

TIMING SPECIFICATIONS

Table 2. (AV_{DD} = 5 V ± 5%; DV_{DD} = 2.7 V to 3.6 V, or 5 V ± 5%; Input Logic 0 = 0 V; Logic 1 = DV_{DD}; unless otherwise noted.)¹

Parameter	Min	Typ	Max	Unit	Test Conditions/Comments
Master Clock Range	1		6.144	MHz	
t ₁	50			ns	$\overline{\text{SYNC}}$ Pulsewidth
t ₂	500			ns	RESET Pulsewidth
Read Operation					
t ₄	0			ns	$\overline{\text{CS}}$ Falling Edge to SCLK Falling Edge Setup Time
t ₅ ²	0		60	ns	SCLK Falling Edge to Data Valid Delay DV _{DD} of 4.75 V to 5.25 V
t _{5A} ^{2,3}	0		80	ns	DV _{DD} of 2.7 V to 3.3 V $\overline{\text{CS}}$ Falling Edge to Data Valid Delay
	0		60	ns	DV _{DD} of 4.75 V to 5.25 V
	0		80	ns	DV _{DD} of 2.7 V to 3.3 V
t ₆	50			ns	SCLK High Pulsewidth
t ₇	50			ns	SCLK Low Pulsewidth
t ₈	0			ns	$\overline{\text{CS}}$ Rising Edge after SCLK Rising Edge Hold Time
t ₉ ⁴	10		80	ns	Bus Relinquish Time after SCLK Rising Edge
Write Operation					
t ₁₁	0			ns	$\overline{\text{CS}}$ Falling Edge to SCLK Falling Edge Setup
t ₁₂	30			ns	Data Valid to SCLK Rising Edge Setup Time
t ₁₃	25			ns	Data Valid after SCLK Rising Edge Hold Time
t ₁₄	50			ns	SCLK High Pulsewidth
t ₁₅	50			ns	SCLK Low Pulsewidth
t ₁₆	0			ns	$\overline{\text{CS}}$ Rising Edge after SCLK Rising Edge Hold Time

¹ Sample tested during initial release to ensure compliance. All input signals are specified with $t_r = t_f = 5$ ns (10% to 90% of DV_{DD}) and timed from a voltage level of 1.6 V. See Figure 2 and Figure 3.

² These numbers are measured with the load circuit of Figure 4 and defined as the time required for the output to cross the V_{OL} or V_{OH} limits.

³ This specification is relevant only if $\overline{\text{CS}}$ goes low while SCLK is low.

⁴ These numbers are derived from the measured time taken by the data output to change 0.5 V when loaded with the circuit of Figure 4. The measured number is then extrapolated back to remove effects of charging or discharging the 50 pF capacitor. This means that the times quoted in the Timing Characteristics are the true bus relinquish times of the part and as such are independent of external bus loading capacitances.

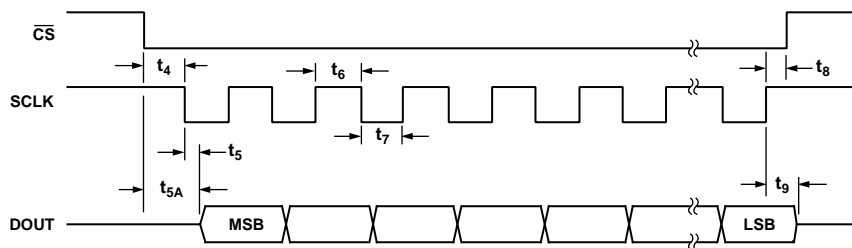

Figure 2. Read Cycle Timing Diagram

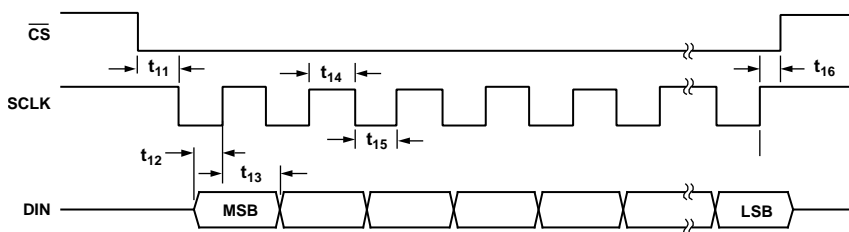

Figure 3. Write Cycle Timing Diagram

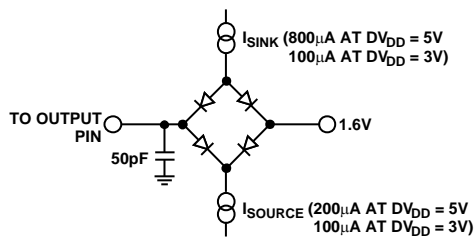

Figure 4. Load Circuit for Access Time and Bus Relinquish Time

AD7732

ABSOLUTE MAXIMUM RATINGS

Table 3. $T_A = 25^\circ\text{C}$, unless otherwise noted.

Parameter	Rating
AV_{DD} to AGND, DV_{DD} to DGND	-0.3 V to +7 V
AGND to DGND	-0.3 V to +0.3 V
AV_{DD} to DV_{DD}	-5 V to +5 V
AIN to AGND	-50 V to +50 V
RA, RB, RC, RD to AGND	-11 V to +25 V
BIAS to AGND	-0.3 V to $AV_{DD} + 0.3$ V
REFIN+, REFIN- to AGND	-0.3 V to $AV_{DD} + 0.3$ V
P0, P1 Voltage to AGND	-0.3 V to $AV_{DD} + 0.3$ V
P0, P1 Current ($T_{MAX} = 70^\circ\text{C}$)	8 mA
P0, P1 Current ($T_{MAX} = 85^\circ\text{C}$)	5 mA
P0, P1 Current ($T_{MAX} = 105^\circ\text{C}$)	2.5 mA
Digital Input Voltage to DGND	-0.3 V to $DV_{DD} + 0.3$ V
Digital Output Voltage to DGND	-0.3 V to $DV_{DD} + 0.3$ V
Operating Temperature Range	-40°C to $+105^\circ\text{C}$
Storage Temperature Range	-65°C to $+150^\circ\text{C}$
Junction Temperature	150°C
TSSOP Package, Power Dissipation	660 mW
θ_{JA} Thermal Impedance	$97.9^\circ\text{C}/\text{W}$
Lead Temperature, Soldering	
Vapor Phase (60 sec)	215°C
Infrared (15 sec)	220°C

Stresses above those listed under Absolute Maximum Ratings may cause permanent damage to the device. This is a stress rating only; functional operation of the device at these or any other conditions above those indicated in the operational section of this specification is not implied. Exposure to absolute maximum rating conditions for extended periods may affect device reliability.

TYPICAL PERFORMANCE CHARACTERISTICS

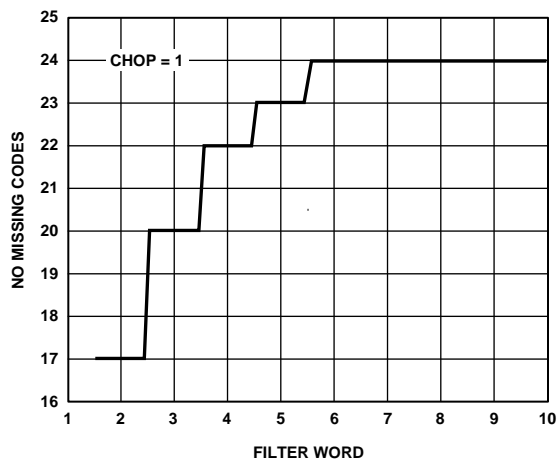

Figure 5. No Missing Codes Performance, Chopping Enabled

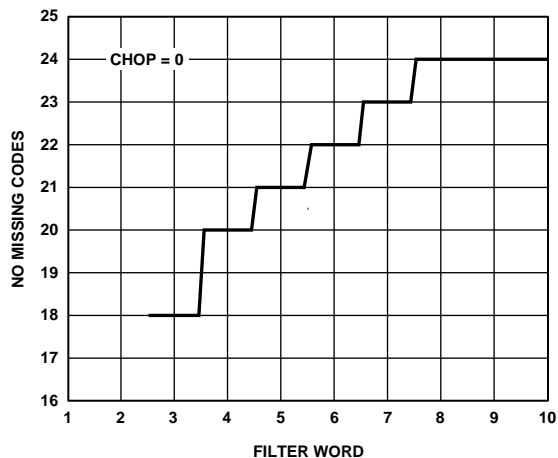

Figure 6. No Missing Codes Performance, Chopping Disabled

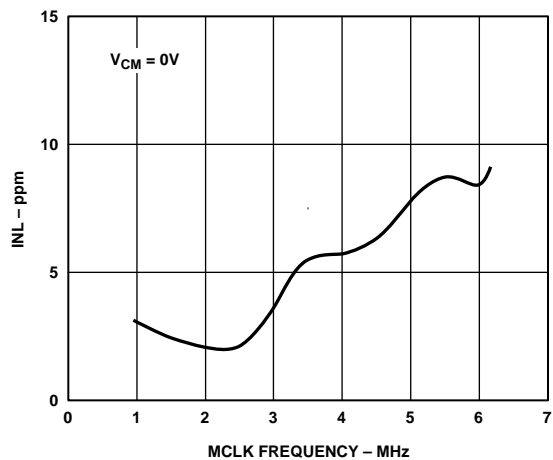

Figure 7. Typical INL vs. MCLK Frequency, ± 10 V Differential Signal, AIN Common-Mode Voltage = 0 V, BIAS(+) = BIAS(-) = 2.5 V

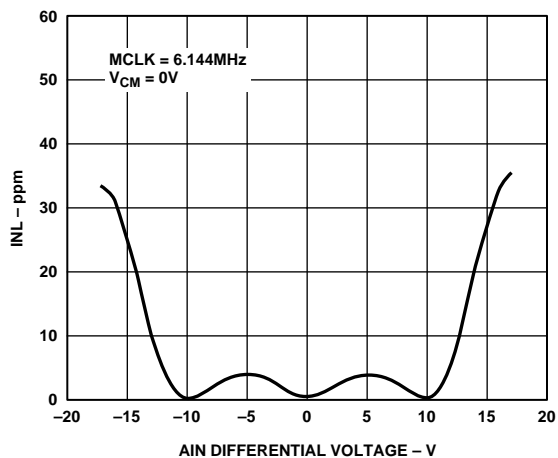

Figure 8. Typical INL vs. AIN Differential Voltage, AIN Common-Mode Voltage = 0 V, MCLK = 6.144 MHz, BIAS(+) = BIAS(-) = 2.5 V

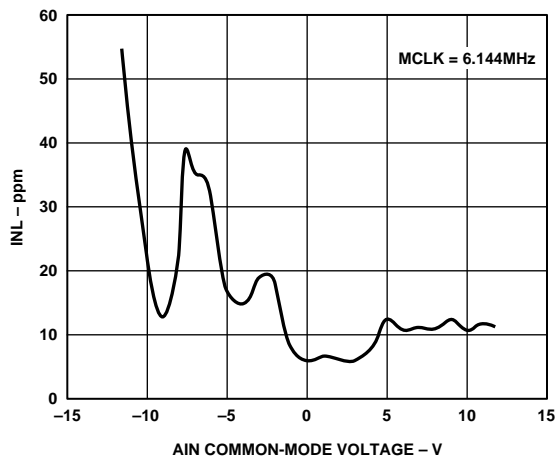

Figure 9. Typical INL vs. AIN Common-Mode Voltage, ± 10 V Differential Signal, MCLK = 6.144 MHz, BIAS(+) = BIAS(-) = 2.5 V

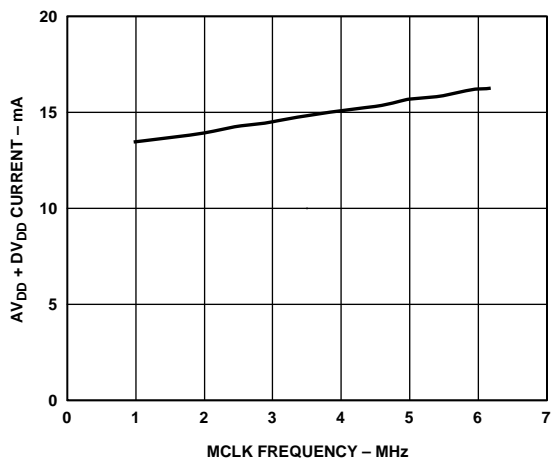

Figure 10. Typical Supply Current vs. MCLK Frequency, Normal Operation, Converting

OUTPUT NOISE AND RESOLUTION SPECIFICATION

The AD7732 can be operated with chopping enabled or disabled, allowing the ADC to be programmed to either optimize the throughput rate and channel switching time or to optimize the offset drift performance. Noise tables for these two primary modes of operation are outlined below for a selection of output rates and settling times.

The AD7732 noise performance depends on the selected chopping mode, the filter word (FW) value, and the selected analog input range. The AD7732 noise will not vary significantly with MCLK frequency.

Chopping Enabled

The first mode, in which the AD7732 is configured with chopping enabled (CHOP = 1), provides very low noise with

lower output rates. Table 4 to Table 6 show the -3 dB frequencies and typical performance versus the channel conversion time and equivalent output data rate, respectively. Table 4 shows the typical output rms noise. Table 5 shows the typical effective resolution based on rms noise. Table 6 shows the typical output peak-to-peak resolution, representing values for which there will be no code flicker within a 6-sigma limit. The peak-to-peak resolutions are not calculated based on rms noise but on peak-to-peak noise.

These typical numbers are generated from 4096 data samples acquired in continuous conversion mode with an analog input voltage set to 0 V and MCLK = 6.144 MHz. The conversion time is selected via the channel conversion time register.

Table 4. Typical Output RMS Noise in μ V vs. Conversion Time and Input Range with Chopping Enabled

FW	Conversion Time Register	Conversion Time (μ s)	Output Data Rate (Hz)	-3 dB Frequency (Hz)	RMS Noise (μ V)
127	FFh	2686	372	200	9.6
46	AEh	999	1001	520	15.5
22	96h	499	2005	1040	22.7
17	91h	395	2534	1300	26.1
8	88h	207	4826	2500	39.2
6	86h	166	6041	3100	46.0
2	82h	82	12166	6300	120.0

Table 5. Typical Effective Resolution in Bits vs. Conversion Time and Input Range with Chopping Enabled

FW	Conversion Time Register	Conversion Time (μ s)	Output Data Rate (Hz)	-3 dB Frequency (Hz)	Input Range/Effective Resolution (Bits)			
					± 10 V	0 V to +10 V	± 5 V	0 V to +5 V
127	FFh	2686	372	200	21.0	20.0	20.0	19.0
46	AEh	999	1001	520	20.3	19.3	19.3	18.3
22	96h	499	2005	1040	19.7	18.7	18.7	17.7
17	91h	395	2534	1300	19.5	18.5	18.5	17.5
8	88h	207	4826	2500	19.0	18.0	18.0	17.0
6	86h	166	6041	3100	18.7	17.7	17.7	16.7
2	82h	82	12166	6300	17.3	16.3	16.3	15.3

Table 6. Typical Peak-to-Peak Resolution in Bits vs. Conversion Time and Input Range with Chopping Enabled

FW	Conversion Time Register	Conversion Time (μ s)	Output Data Rate (Hz)	-3 dB Frequency (Hz)	Input Range/Peak-to-Peak Resolution (Bits)			
					± 10 V	0 V to +10 V	± 5 V	0 V to +5 V
127	FFh	2686	372	200	18.1	17.1	17.1	16.1
46	AEh	999	1001	520	17.4	16.4	16.4	15.4
22	96h	499	2005	1040	16.9	15.9	15.9	14.9
17	91h	395	2534	1300	16.7	15.7	15.7	14.7
8	88h	207	4826	2500	16.2	15.2	15.2	14.2
6	86h	166	6041	3100	15.8	14.8	14.8	13.8
2	82h	82	12166	6300	15.0	13.4	13.4	12.4

Chopping Disabled

The second mode, in which the AD7732 is configured with chopping disabled (CHOP = 0), provides faster conversion time while still maintaining high resolution. Table 7 to Table 9 show the -3 dB frequencies and typical performance versus the channel conversion time and equivalent output data rate, respectively. Table 7 shows the typical output rms noise. Table 8 shows the typical effective resolution based on the rms noise. Table 9 shows the typical output peak-to-peak resolution,

representing values for which there will be no code flicker within a 6-sigma limit. The peak-to-peak resolutions are not calculated based on rms noise but on peak-to-peak noise.

These typical numbers are generated from 4096 data samples acquired in continuous conversion mode with an analog input voltage set to 0 V and MCLK = 6.144 MHz. The conversion time is selected via the channel conversion time register.

Table 7. Typical Output RMS Noise in μV vs. Conversion Time and Input Range with Chopping Disabled

FW	Conversion Time Register	Conversion Time (μs)	Output Data Rate (Hz)	-3 dB Frequency (Hz)	RMS Noise (μV)
127	7Fh	1357	737	670	13.2
92	5Ch	992	1008	920	15.5
44	2Ch	492	2032	1850	22.7
35	23h	398	2511	2290	26.3
16	10h	200	4991	2500	39.0
8	08h	117	8545	7780	57.0
3	03h	65	15398	14000	132

Table 8. Typical Effective Resolution in Bits vs. Conversion Time and Input Range with Chopping Disabled

FW	Conversion Time Register	Conversion Time (μs)	Output Data Rate (Hz)	-3 dB Frequency (Hz)	Input Range/Effective Resolution (Bits)			
					$\pm 10\text{ V}$	0 V to +10 V	$\pm 5\text{ V}$	0 V to +5 V
127	7Fh	1357	737	670	20.5	19.5	19.5	18.5
92	5Ch	992	1008	920	20.3	19.3	19.3	18.3
44	2Ch	492	2032	1850	19.7	18.7	18.7	17.7
35	23h	398	2511	2290	19.5	18.5	18.5	17.5
16	10h	200	4991	2500	19.0	18.0	18.0	17.0
8	08h	117	8545	7780	18.4	17.4	17.4	16.4
3	03h	65	15398	14000	17.2	16.2	16.2	15.2

Table 9. Typical Peak-to-Peak Resolution in Bits vs. Conversion Time and Input Range with Chopping Disabled

FW	Conversion Time Register	Conversion Time (μs)	Output Data Rate (Hz)	-3 dB Frequency (Hz)	Input Range/Peak-to-Peak Resolution (Bits)			
					$\pm 10\text{ V}$	0 V to +10 V	$\pm 5\text{ V}$	0 V to +5 V
127	7Fh	1357	737	670	17.6	16.6	16.6	15.6
92	5Ch	992	1008	920	17.4	16.4	16.4	15.4
44	2Ch	492	2032	1850	16.8	15.8	15.8	14.8
35	23h	398	2511	2290	16.6	15.6	15.6	14.6
16	10h	200	4991	2500	16.1	15.1	15.1	14.1
8	08h	117	8545	7780	15.5	14.5	14.5	13.5
3	03h	65	15398	14000	14.3	13.3	13.3	12.3

PIN CONFIGURATIONS AND FUNCTIONAL DESCRIPTIONS

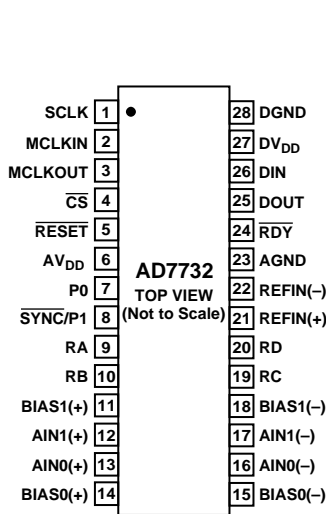

Figure 11. 28-Lead TSSOP

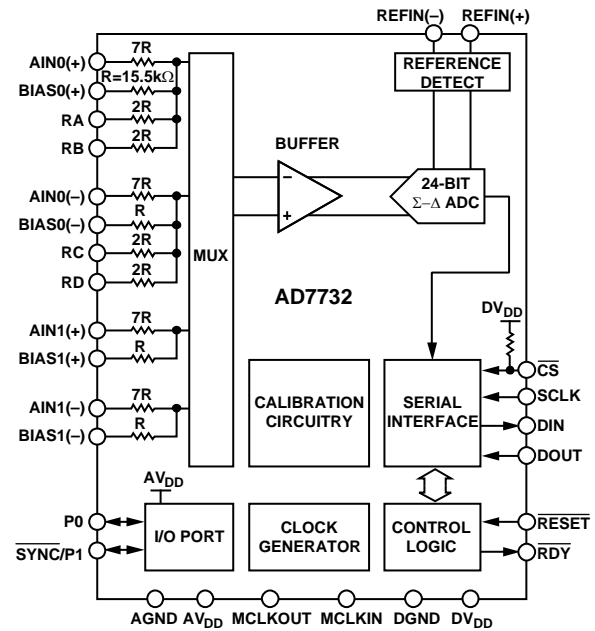

Figure 12. Block Diagram

Table 10. Pin Function Descriptions—28-Lead TSSOP

Pin No.	Mnemonic	Description
1	SCLK	Serial Clock. Schmitt triggered logic input. An external serial clock is applied to this input to transfer serial data to or from the AD7732.
2	MCLKIN	Master Clock Signal for the ADC. This can be provided in the form of a crystal/resonator or external clock. A crystal/resonator can be tied across the MCLKIN and MCLKOUT pins. Alternatively, the MCLKIN pin can be driven with a CMOS compatible clock and MCLKOUT left unconnected.
3	MCLKOUT	When the master clock for the device is a crystal/resonator, the crystal/resonator is connected between MCLKIN and MCLKOUT. If an external clock is applied to the MCLKIN, MCLKOUT provides an inverted clock signal or can be switched off to reduce the device power consumption. MCLK OUT is capable of driving one CMOS load.
4	$\overline{\text{CS}}$	Chip Select. Active low Schmitt triggered logic input with an internal pull-up resistor. With this input hardwired low, the AD7732 can operate in its 3-wire interface mode using SCLK, DIN, and DOUT. $\overline{\text{CS}}$ can be used to select the device in systems with more than one device on the serial bus. It can also be used as an 8-bit frame synchronization signal.
5	$\overline{\text{RESET}}$	Schmitt Triggered Logic Input. Active low input that resets the control logic, interface logic, digital filter, analog modulator, and all on-chip registers of the part to power-on status. Effectively, everything on the part except the clock oscillator is reset when the $\overline{\text{RESET}}$ pin is exercised.
6	AV _{DD}	Analog Positive Supply Voltage. 5 V to AGND nominal.
7	P0	Digital Input/Output. The pin direction is determined by the P0 DIR bit; the digital value can be read/written as the P0 bit in the I/O port register. The digital voltage is referenced to analog supplies. When configured as an input, the pin should be tied high or low.

Pin No.	Mnemonic	Description
8	$\overline{\text{SYNC/P1}}$	SYNC/Digital Input/Digital Output. The pin direction is determined by the P1 DIR bit; the digital value can be read/written as the P1 bit in the I/O port register. When the SYNC bit in the I/O port register is set to 1, the $\overline{\text{SYNC/P1}}$ pin can be used to synchronize the AD7732 modulator and digital filter with other devices in the system. The digital voltage is referenced to analog supplies. When configured as an input, the pin should be tied high or low.
9	RA	RA, in association with RB and BIAS0(+), can be used to level shift the positive analog input 0. In normal circuit configuration, this pin is left open circuit.
10	RB	RB, in association with RA and BIAS0(+), can be used to level shift the positive analog input 0. In normal circuit configuration, this pin is left open circuit.
11	BIAS1(+)	This input is used to level shift the positive analog input 1. This signal is used to ensure that the differential signal seen by the internal buffer amplifier is within its common-mode range. BIAS pins will normally be connected to 2.5 V.
12	AIN1(+)	Positive Analog Input Channel 1.
13	AIN0(+)	Positive Analog Input Channel 0.
14	BIAS0(+)	Voltage Bias for Positive Analog Input 0. This pin has the same function as BIAS1(+).
15	BIAS0(-)	Voltage Bias for Negative Analog Input 0. This pin has the same function as BIAS1(+).
16	AIN0(-)	Negative Analog Input Channel 0.
17	AIN1(-)	Negative Analog Input Channel 1.
18	BIAS1(-)	Voltage Bias for Negative Analog Input 1. This pin has the same function as BIAS1(+).
19	RC	RC, in association with RD and BIAS0(-), can be used to level shift the negative analog input 0. In normal circuit configuration, this pin is left open circuit.
20	RD	RD, in association with RC and BIAS0(-), can be used to level shift the negative analog input 0. In normal circuit configuration, this pin is left open circuit.
21	REFIN(+)	Positive Terminal of the Differential Reference Input. REFIN(+) voltage potential can lie anywhere between AV_{DD} and AGND. In normal circuit configuration, this pin should be connected to a 2.5 V reference voltage.
22	REFIN(-)	Negative Terminal of the Differential Reference Input. REFIN(-) voltage potential can lie anywhere between AV_{DD} and AGND. In normal circuit configuration, this pin should be connected to a 0 V reference voltage.
23	AGND	Ground Reference Point for Analog Circuitry.
24	$\overline{\text{RDY}}$	Logic Output. Used as a status output in both conversion mode and calibration mode. In conversion mode, a falling edge on this output indicates that either any channel or all channels have unread data available, according to the RDYFN bit in the I/O port register. In calibration mode, a falling edge on this output indicates that calibration is complete (see the Digital Interface Description section for more details).
25	DOUT	Serial data output with serial data being read from the output shift register on the part. This output shift register can contain information from any AD7732 register, depending on the address bits of the communications register.
26	DIN	Serial data input (Schmitt triggered) with serial data being written to the input shift register on the part. Data from this input shift register is transferred to any AD7732 register, depending on the address bits of the communications register.
27	DV_{DD}	Digital Supply Voltage, 3 V or 5 V Nominal.
28	DGND	Ground Reference Point for Digital Circuitry.

REGISTER DESCRIPTION

Table 11. Register Summary

Register	Addr	Dir	Bit 7	Bit 6	Bit 5	Bit 4	Bit 3	Bit 2	Bit 1	Bit 0
	(hex)		Default Value							
Communications	00	W	0	R/W	6-Bit Register Address					
I/O Port	01	R/W	P0	P1	P0 DIR	P1 DIR	RDYFN	0	0	SYNC
			P0 Pin	P1 Pin	1	1	0	0	0	0
Revision	02	R	Chip Revision Code				Chip Generic Code			
			x	x	x	x	0	1	0	0
Test	03	R/W	24-Bit Manufacturing Test Register							
ADC Status	04	R	–	–	–	–	–	RDY1	–	RDY0
			0	0	0	0	0	0	0	0
Checksum	05	R/W	16-Bit Checksum Register							
ADC Zero-Scale Calibration	06	R/W	24-Bit ADC Zero-Scale Calibration Register							
			800000h							
ADC Full-Scale	07	R/W	24-Bit ADC Full-Scale Register							
			800000h							
Channel Data ¹	08, 0A	R	16-/24-Bit Data Registers							
			8000h							
Channel Zero-Scale Cal. ¹	10, 12	R/W	24-Bit Channel Zero-Scale Calibration Registers							
			800000h							
Channel Full-Scale Cal. ¹	18, 1A	R/W	24-Bit Channel Full-Scale Calibration Registers							
			200000h							
Channel Status ¹	20, 22	R	0	CH1	0	0/P0	RDY/P1	NOREF	SIGN	OVR
			Channel Number			0	0	0	0	0
Channel Setup ¹	28, 2A	R/W	0	0	0	Stat OPT	ENABLE	0	RNG1	RNG0
			0	0	0	0	0	0	0	0
Channel Conversion Time ¹	30, 32	R/W	CHOP	FW (7-Bit Filter Word)						
			1	11h						
Mode ²	38, 3A	R/W	MD2	MD1	MD0	CLKDIS	DUMP	Cont RD	24/16 BIT	CLAMP
			0	0	0	0	0	0	0	0

¹Bit 1 in the communication register specifies the channel number of the register being accessed.

²There is only one mode register, although the mode register can be accessed in one of two address locations. The address used to write the mode register specifies the ADC channel on which the mode will be applied. Only address 38h must be used for reading from the mode register.

Table 12. Operational Mode Summary

MD2	MD1	MD0	Mode
0	0	0	Idle Mode
0	0	1	Continuous Conversion Mode
0	1	0	Single Conversion Mode
0	1	1	Power-Down (Standby) Mode
1	0	0	ADC Zero-Scale Self-Calibration
1	0	1	For Future Use
1	1	0	Channel Zero-Scale System Calibration
1	1	1	Channel Full-Scale System Calibration

Table 13. Input Range Summary

RNG1	RNG0	Nominal Input Voltage Range
0	0	±10 V
0	1	0 V to +10 V
1	0	±5 V
1	1	0 V to +5 V

Register Access

The AD7732 is configurable through a series of registers. Some of them configure and control general AD7732 features, while others are specific to each channel. The register data widths vary from 8 bits to 24 bits. All registers are accessed through the communications register, i.e., any communication to the AD7732 must start with a write to the communications register specifying which register will be subsequently read or written.

Communications Register

8 Bits, Write-Only Register, Address 00h

All communications to the part must start with a write operation to the communications register. The data written to

the communications register determines whether the subsequent operation will be a read or write and to which register this operation will be directed. The digital interface defaults to expect write operation to the communications register after power-on, after reset, or after the subsequent read or write operation to the selected register is complete. If the interface sequence is lost, the part can be reset by writing at least 32 serial clock cycles with DIN high and \overline{CS} low. (Note that all of the parts, including the modulator, filter, interface, and all registers are reset in this case.) Remember to keep DIN low while reading 32 bits or more either in continuous read mode or with the DUMP bit and “24/16” bit in the mode register set.

Bit	Bit 7	Bit 6	Bit 5	Bit 4	Bit 3	Bit 2	Bit 1	Bit 0
Mnemonic	0	R/W	6-Bit Register Address					

Bit	Mnemonic	Description
7	0	This bit must be 0 for proper operation.
6	$\overline{R/W}$	A 0 in this bit indicates that the next operation will be a write to a specified register. A 1 in this bit indicates that the next operation will be a read from a specified register.
5–0	Address	Address specifying to which register the read or write operation will be directed. For channel specific registers, Bit 1 specifies the channel number. When the subsequent operation writes to the Mode register, Bit 1 specifies the channel selected for operation determined by the mode register value (see Table 14).

Table 14.

Bit 2	Bit 1	Bit 0	Channel	Input
0	0	0	0	AIN0(+) – AIN0(–)
0	1	0	1	AIN1(+) – AIN1(–)

AD7732

I/O Port Register

8 Bits, Read/Write Register, Address 01h, Default Value 30h + Digital Input Value × 40h

The bits in this register are used to configure and access the digital I/O port on the AD7732.

Bit	Bit 7	Bit 6	Bit 5	Bit 4	Bit 3	Bit 2	Bit 1	Bit 0
Mnemonic	P0	P1	P0 DIR	P1 DIR	RDYFN	0	0	SYNC
Default	P0 Pin	P1 Pin	1	1	0	0	0	0

Bit	Mnemonic	Description
7, 6	P0, P1	When the P0 and P1 pins are configured as outputs, the P0 and P1 bits determine the pins' output level. When the P0 and P1 pins are configured as inputs, the P0 and P1 bits reflect the current input level on the pins.
5, 4	P0 DIR, P1 DIR	These bits determine whether the P0 and P1 pins are configured as inputs or outputs. When set to 1, the corresponding pin will be an input; when reset to 0, the corresponding pin will be an output.
3	RDYFN	This bit is used to control the function of the $\overline{\text{RDY}}$ pin on the AD7732. When this bit is reset to 0, the $\overline{\text{RDY}}$ pin goes low when any channel has unread data. When this bit is set to 1, the $\overline{\text{RDY}}$ pin will only go low if all enabled channels have unread data.
2, 1	0	These bits must be 0 for proper operation.
0	SYNC	This bit enables the $\overline{\text{SYNC}}$ pin function. By default, this bit is 0 and $\overline{\text{SYNC}}$ /P1 can be used as a digital I/O pin. When the SYNC bit is set to 1, the $\overline{\text{SYNC}}$ pin can be used to synchronize the AD7732 modulator and digital filter with other devices in the system.

Revision Register

8 Bits, Read-Only Register, Address 02h, Default Value 04h + Chip Revision × 10h

Bit	Bit 7	Bit 6	Bit 5	Bit 4	Bit 3	Bit 2	Bit 1	Bit 0
Mnemonic	Chip Revision Code				Chip Generic Code			
Default	x	x	x	x	0	1	0	0

Bit	Mnemonic	Description
7-4	Chip Revision Code	4-Bit Factory Chip Revision Code
3-0	Chip Generic Code	On the AD7732, these bits will read back as 04h.

Test Register

24 Bits, Read/Write Register, Address 03h

This register is used for testing the part in the manufacturing process. The user must not change the default configuration of this register.

ADC Status Register

8 Bits, Read-Only Register, Address 04h, Default Value 00h

In conversion modes, the register bits reflect the individual channel status. When a conversion is complete, the corresponding channel data register is updated and the corresponding RDY bit is set to 1. When the channel data register is read, the corresponding bit is reset to 0. The bit is also reset to 0 when no read operation has taken place and the result of the next conversion is being updated to the channel data register. Writing to the mode register resets all the bits to 0.

In calibration modes, all the register bits are reset to 0 while a calibration is in progress; all the register bits are set to 1 when the calibration is complete.

The $\overline{\text{RDY}}$ pin output is related to the content of the ADC status register as defined by the RDYFN bit in the I/O port register.

The RDY0 bit corresponds to the differential input 0, and the RDY1 bit corresponds to the differential input 1.

Bit	Bit 7	Bit 6	Bit 5	Bit 4	Bit 3	Bit 2	Bit 1	Bit 0
Mnemonic	–	–	–	–	–	RDY1	–	RDY0
Default	0	0	0	0	0	0	0	0

Checksum Register

16 Bits, Read/Write Register, Address 05h

This register is described in the *Using the AD7732/AD7734/AD7738/AD7739 Checksum Register* application note, (www.analog.com/AN-626).

ADC Zero-Scale Calibration Register

24 Bits, Read/Write Register, Address 06h, Default Value 800000h

The register holds the ADC zero-scale calibration coefficient. The value in this register is used in conjunction with the value in the ADC full-scale calibration register and the corresponding channel zero-scale and channel full-scale calibration registers to scale digitally all channels' conversion results. The value in this register is updated automatically following the execution of an ADC zero-scale self-calibration. Writing this register is possible in the idle mode only (see the Calibration section for more details).

ADC Full-Scale Register

24 Bits, Read/Write Register, Address 07h, Default Value 800000h

This register holds the ADC full-scale coefficient. The user is advised not to change the default configuration of this register.

Channel Data Registers

16 Bit/24 Bit, Read-Only Registers, Address 08h, 0Ah, Default Width 16 Bits, Default Value 8000h

These registers contain the most up-to-date conversion results corresponding to each analog input channel. The 16-bit or 24-bit data width can be configured by setting the 16 bit/24 bit in the mode register. The relevant RDY bit in the channel status register goes high when the result is updated. The RDY bit will return low once the data register reading has begun. The $\overline{\text{RDY}}$ pin can be configured to indicate when any channel has unread data or waits until all enabled channels have unread data. If any channel data register read operation is in progress when a new result is updated, no update of the data register will occur. This avoids having corrupted data. Reading the status registers can be associated with reading the data registers in the dump mode. Reading the status registers is always associated with reading the data registers in the continuous read mode (see the Digital Interface Description section for more details).

Channel Zero-Scale Calibration Registers

24 Bits, Read/Write Registers, Address 10h, 12h, Default Value 800000h

These registers hold the particular channel zero-scale calibration coefficients. The value in these registers is used in conjunction with the value in the corresponding channel full-scale calibration register, the ADC zero-scale calibration register, and the ADC full-scale register to digitally scale the particular channel conversion results. The value in this register is updated automatically following the execution of a channel zero-scale system calibration.

The format of the channel zero-scale calibration register is a sign bit and 22 bits unsigned value. Writing this register is possible in the idle mode only (see the Calibration section for more details).

Channel Status Registers

8 Bits, Read-Only Register, Address 20h, 22h, Default Value 20h × Channel Number

These registers contain individual channel status information and some general AD7732 status information. Reading the status registers can be associated with reading the data registers in the dump mode. Reading the status registers is always associated with reading the data registers in the continuous read mode (see the Digital Interface Description section for more details).

Channel Full-Scale Calibration Registers

24 Bits, Read/Write Registers, Address 18h, 1Ah, Default Value 200000h

These registers hold the particular channel full-scale calibration coefficients. The value in these registers is used in conjunction with the value in the corresponding channel zero-scale calibration register, the ADC zero-scale calibration register, and the ADC full-scale register to digitally scale the particular channel conversion results. The value in this register is updated automatically following the execution of a channel full-scale system calibration. Writing this register is possible in the idle mode only (see the Calibration section for more details).

Bit	Bit 7	Bit 6	Bit 5	Bit 4	Bit 3	Bit 2	Bit 1	Bit 0
Mnemonic	0	CH1	0	O/P0	RDY/P1	NOREF	SIGN	OVR
Default	Channel Number			0	0	0	0	0

Bit	Mnemonic	Description
7–5	CH1	These bits reflect the channel number. This can be used for current channel identification and easier operation of the dump mode and continuous read mode.
4	O/P0	When the status option bit of the corresponding channel setup register is reset to 0, this bit is read as a zero. When the status option bit is set to 1, this bit reflects the state of the P0 pin, whether it is configured as an input or an output.
3	RDY/P1	When the status option bit of the corresponding channel setup register is reset to 0, this bit reflects the selected channel RDY bit in the ADC status register. When the status option bit is set to 1, this bit reflects the state of the P1 pin, whether it is configured as an input or an output.
2	NOREF	This bit indicates the reference input status. If the voltage between the REFIN(+) and REFIN(–) pins is less than NOREF, the trigger voltage and a conversion is executed, then the NOREF bit goes to 1.
1	SIGN	The voltage polarity at the analog input. It will be 0 for a positive voltage and 1 for a negative voltage.
0	OVR	This bit reflects either the overrange or the underrange on the analog input. The bit is set to 1 when the analog input voltage goes over or under the nominal voltage range (see the Analog Input’s Extended Voltage Range section).

Channel Setup Registers

8 Bits, Read/Write Register, Address 28h, 2Ah, Default Value 00h

These registers are used to configure the selected channel, to configure its input voltage range, and to set up the corresponding channel status register.

Bit	Bit 7	Bit 6	Bit 5	Bit 4	Bit 3	Bit 2	Bit 1	Bit 0
Mnemonic	0	0	0	Stat OPT	ENABLE	0	RNG1	RNG0
Default	0	0	0	0	0	0	0	0

Bit	Mnemonic	Description
7-5	0	These bits must be 0 for proper operation.
4	Stat OPT	Status Option. When this bit is set to 1, the P0 and P1 bits in the channel status register will reflect the state of the P0 and P1 pins. When this bit is reset to 0, the RDY bit in the channel status register will reflect the channel corresponding to the RDY bit in the ADC status register.
3	ENABLE	Channel Enable. Set this bit to 1 to enable the channel in the continuous conversion mode. A single conversion will take place regardless of this bit's value.
2	0	This bit must be 0 for proper operation.
1-0	RNG1-RNG0	This is the channel input voltage range (see Table 15).

Table 15.

RNG1	RNG0	Nominal Input Voltage Range
0	0	±10 V
0	1	0 V to +10 V
1	0	±5 V
1	1	0 V to +5 V

Channel Conversion Time Registers

8 Bits, Read/Write Register, Address 30h, 32h, Default Value 91h

The conversion time registers enable or disable chopping and configure the digital filter for a particular channel. This register value affects the conversion time, frequency response, and noise performance of the ADC.

Bit	Bit 7	Bit 6	Bit 5	Bit 4	Bit 3	Bit 2	Bit 1	Bit 0
Mnemonic	CHOP	FW (7-Bit Filter Word)						
Default	1	11h						

Bit	Mnemonic	Description
7	CHOP	Chopping Enable Bit. Set to 1 to apply chopping mode for a particular channel.
6-0	FW	<p>CHOP = 1, single conversion or continuous conversion with one channel enabled. Conversion Time (μs) = (FW \times 128 + 248)/MCLK Frequency (MHz), the FW range is 2 to 127.</p> <p>CHOP = 1, continuous conversion with two channels enabled. Conversion Time (μs) = (FW \times 128 + 249)/MCLK Frequency (MHz), the FW range is 2 to 127.</p> <p>CHOP = 0, single conversion or continuous conversion with one channel enabled. Conversion Time (μs) = (FW \times 64 + 206)/MCLK Frequency (MHz), the FW range is 3 to 127.</p> <p>CHOP = 0, continuous conversion with two channels enabled. Conversion Time (μs) = (FW \times 64 + 207)/MCLK Frequency (MHz), the FW range is 3 to 127.</p>

AD7732

Mode Register

8 Bits, Read/Write Register, Address 38h, 3Ah, Default Value 00h

The mode register configures the part and determines its operating mode. Writing to the mode register clears the ADC status register, sets the $\overline{\text{RDY}}$ pin to a logic high level, exits all current operations, and starts the mode specified by the mode bits.

The AD7732 contains only one mode register. Bit 1 of the address is used for writing to the mode register to specify the channel selected for the operation determined by the MD2 to MD0 bits. Only the address 38h must be used for reading from the mode register.

Bit	Bit 7	Bit 6	Bit 5	Bit 4	Bit 3	Bit 2	Bit 1	Bit 0
Mnemonic	MD2	MD1	MD0	CLKDIS	DUMP	Cont RD	24/16 BIT	CLAMP
Default	0	0	0	0	0	0	0	0

Bit	Mnemonic	Description
7–5	MD2–MD0	Mode Bits. These three bits determine the AD7732 operation mode. Writing a new value to the mode bits will exit the part from the mode in which it has been operating and place it in the newly requested mode immediately. The function of the mode bits is described in more detail below.
4	CLKDIS	Master Clock Output Disable. When this bit is set to 1, the master clock is disabled from appearing at the MCLKOUT pin and the MCLKOUT pin is in a high impedance state. This allows turning off the MCLKOUT as a power saving feature. When using an external clock on MCLKIN, the AD7732 continues to have internal clocks and will convert normally regardless of the CLKDIS bit state. When using a crystal oscillator or ceramic resonator across the MCLKIN and MCLKOUT pins, the AD7732 clock is stopped and no conversions can take place when the CLKDIS bit is active. The AD7732 digital interface can still be accessed using the SCLK pin.
3	DUMP	DUMP Mode. When this bit is reset to 0, the channel status register and channel data register will be addressed and read separately. When the DUMP bit is set to 1, the channel status register will be followed immediately by a read of the channel data register regardless of whether the status or data register has been addressed through the communication register. The continuous read mode will always be dump mode reading of the channel status and data register, regardless of the dump bit value (see the Digital Interface Description section for more details).
2	Cont RD	When this bit is set to 1, the AD7732 will operate in the continuous read mode (see the Digital Interface Description section for more details).
1	24/16 BIT	The Channel Data Register Data Width Selection Bit. When set to 1, the channel data registers will be 24 bits wide. When set to 0, the channel data registers will be 16 bits wide.
0	CLAMP	This bit determines the channel data register's value when the analog input voltage is outside the nominal input voltage range. When the CLAMP bit is set to 1, the channel data register will be digitally clamped either to all 0s or all 1s when the analog input voltage goes outside the nominal input voltage range. When the CLAMP bit is reset to 0, the data registers reflect the analog input voltage even outside the nominal voltage range (see the Analog Input's Extended Voltage Range section).

MD2	MD1	MD0	Mode	Address Used for Mode Register Write Specifies:
0	0	0	Idle Mode	
0	0	1	Continuous Conversion Mode	The First Channel to Start Converting
0	1	0	Single Conversion Mode	Channel to Convert
0	1	1	Power-Down (Standby) Mode	
1	0	0	ADC Zero-Scale Self-Calibration	Channel Conversion Time Used for the ADC Self-Calibration
1	0	1	For Future Use	
1	1	0	Channel Zero-Scale System Calibration	Channel to Calibrate
1	1	1	Channel Full-Scale System Calibration	Channel to Calibrate

MD2	MD1	MD0	Operating Mode
0	0	0	<p>Idle Mode</p> <p>The default mode after power-on or reset.</p> <p>The AD7732 automatically returns to this mode after any calibration or after a single conversion.</p>
0	0	1	<p>Continuous Conversion Mode</p> <p>The AD7732 performs a conversion on the specified channel. After the conversion is complete, the relevant channel data register and channel status register are updated, the relevant RDY bit in the ADC status register is set, and the AD7732 continues converting on the next enabled channel. The part will cycle through all enabled channels until it is put into another mode or reset. The cycle period will be the sum of all enabled channels' conversion times, set by the corresponding channel conversion time registers.</p>
0	1	0	<p>Single Conversion Mode</p> <p>The AD7732 performs a conversion on the specified channel. After the conversion is complete, the relevant channel data register and channel status register are updated, the relevant RDY bit in the ADC status register is set, the RDY pin goes low, the MD2–MD0 bits are reset, and the AD7732 returns to idle mode. Requesting a single conversion ignores the channel setup register enable bits; a conversion will be performed even if that channel is disabled.</p>
0	1	1	<p>Power-Down (Standby) Mode</p> <p>The ADC and the analog front end (internal buffer) go into the power-down mode.</p> <p>The AD7732 digital interface can still be accessed. The CLKDIS bit works separately, and the MCLKOUT mode is not affected by the power-down (standby) mode.</p>
1	0	0	<p>ADC Zero-Scale Self-Calibration Mode</p> <p>A zero-scale self-calibration is performed on internally shorted ADC inputs.</p> <p>After the calibration is complete, the contents of the ADC zero-scale calibration register are updated, all RDY bits in the ADC status register are set, the RDY pin goes low, the MD2–MD0 bits are reset, and the AD7732 returns to idle mode.</p>
1	0	1	For Future Use.
1	1	0	<p>Channel Zero-Scale System Calibration Mode</p> <p>A zero-scale system calibration is performed on the selected channel. An external system zero-scale voltage should be provided at the AD7732 analog input and should remain stable for the duration of the calibration. After the calibration is complete, the contents of the corresponding channel zero-scale calibration register are updated, all RDY bits in the ADC status register are set, the RDY pin goes low, the MD2–MD0 bits are reset, and the AD7732 returns to idle mode.</p>
1	1	1	<p>Channel Full-Scale System Calibration Mode</p> <p>A full-scale system calibration is performed on the selected channel. An external system full-scale voltage should be provided at the AD7732 analog input and this voltage should remain stable for the duration of the calibration. After the calibration is complete, the contents of the corresponding channel full-scale calibration register are updated, all RDY bits in the ADC status register are set, the RDY pin goes low, the MD2–MD0 bits are reset, and the AD7732 returns to idle mode.</p>

DIGITAL INTERFACE DESCRIPTION

Hardware

The AD7732 serial interface can be connected to the host device via the serial interface in several different ways.

The $\overline{\text{CS}}$ pin can be used to select the AD7732 as one of several circuits connected to the host serial interface. When $\overline{\text{CS}}$ is high, the AD7732 ignores the SCLK and DIN signals and the DOUT pin goes to the high impedance state. When the $\overline{\text{CS}}$ signal is not used, connect the $\overline{\text{CS}}$ pin to DGND.

The $\overline{\text{RDY}}$ pin can be polled for high-to-low transition or can drive the host device interrupt input to indicate that the AD7732 has finished the selected operation and/or new data from the AD7732 is available. The host system can also wait a designated time after a given command is written to the device before reading. Alternatively, the AD7732 status can be polled. When the $\overline{\text{RDY}}$ pin is not used in the system, it should be left as an open circuit. (Note that the $\overline{\text{RDY}}$ pin is always an active digital output, i.e., it never goes into a high impedance state.)

The $\overline{\text{RESET}}$ pin can be used to reset the AD7732. When not used, connect this pin to DV_{DD}.

The AD7732 interface can be reduced to just two wires connecting the DIN and DOUT pins to a single bidirectional data line. The second signal in this 2-wire configuration is the SCLK signal. The host system should change the data line direction with reference to the AD7732 timing specification (see the Bus Relinquish Time in Table 2). The AD7732 cannot operate in the continuous read mode in 2-wire serial interface configuration.

All the digital interface inputs are Schmitt-Triggered; therefore, the AD7732 interface features higher noise immunity and can be easily isolated from the host system via optocouplers. Figure 13, Figure 14, and Figure 15 outline some of the possible host device interfaces: SPI without using the $\overline{\text{CS}}$ signal (Figure 13), a DSP interface (Figure 14), and a 2-wire configuration (Figure 15).

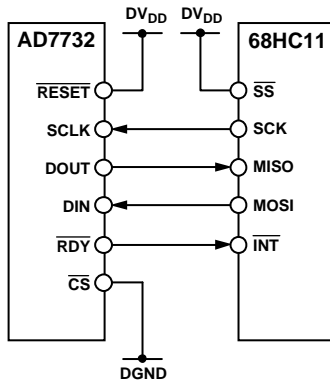

Figure 13. AD7732 to Host Device Interface, SPI

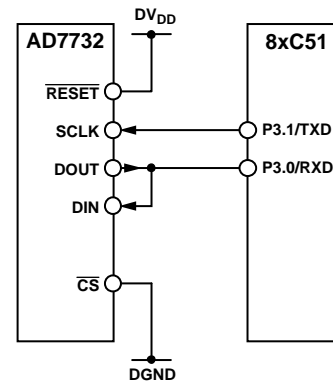

Figure 15. AD7732 to Host Device Interface, 2-Wire Configuration

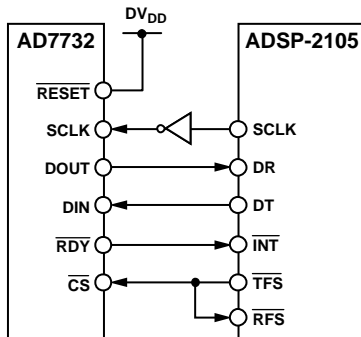

Figure 14. AD7732 to Host Device Interface, DSP

Reset

The AD7732 can be reset by the $\overline{\text{RESET}}$ pin or by writing a reset sequence to the AD7732 serial interface.

The reset sequence is $N \times 0 + 32 \times 1$, which could be the data sequence 00h + FFh + FFh + FFh + FFh in a byte-oriented interface. The AD7732 also features a power-on reset with a trip point of 2 V and goes to the defined default state after power-on.

It is the system designer's responsibility to prevent an unwanted write operation to the AD7732. The unwanted write operation could happen when a spurious clock appears on the SCLK while the $\overline{\text{CS}}$ pin is low. It should be noted that on system power-on, if the AD7732 interface signals are floating or undefined, the part can be inadvertently configured into an unknown state. This could be easily overcome by initiating either a hardware reset event or a 32 ones reset sequence as the first step in the system configuration.

Access the AD7732 Registers

All communications to the part start with a write operation to the communications register followed by either reading or writing the addressed register.

In a simultaneous read-write interface (such as SPI), write 0 to the AD7732 while reading data.

Figure 16 shows the AD7732 interface read sequence for the ADC status register.

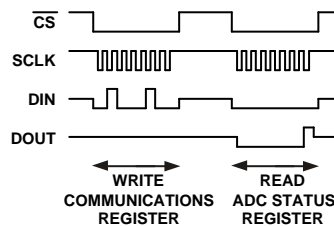

Figure 16. Serial Interface Signals—Registers Access

Single Conversion and Reading Data

When the mode register is being written, the ADC status byte is cleared and the RDY pin goes high, regardless of its previous state. When the single conversion command is written to the mode register, the ADC starts the conversion on the channel selected by the address of the mode register. After the conversion is completed, the data register is updated, the mode register is changed to idle mode, the relevant RDY bit is set, and the RDY pin goes low. The RDY bit is reset and the RDY pin returns high when the relevant channel data register is being read.

Figure 17 shows the digital interface signals executing a single conversion on Channel 0, waiting for the RDY pin to go low, and reading the Channel 0 data register.

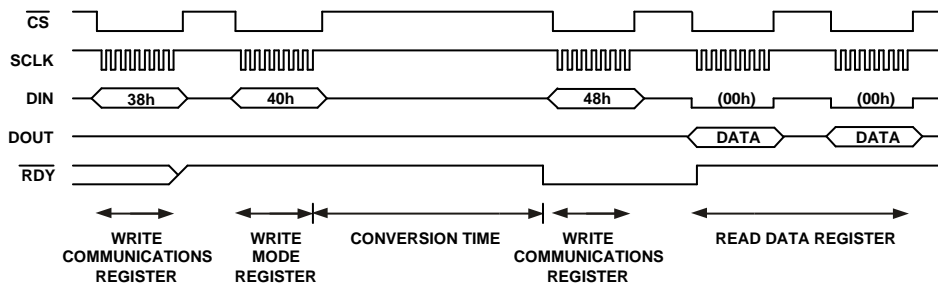

Figure 17. Serial Interface Signals—Single Conversion Command and 16-Bits Data Reading

Dump Mode

When the DUMP bit in the mode register is set to 1, the channel status register will be read immediately by a read of the channel data register, regardless of whether the status or the data register has been addressed through the communications register. The DIN pin should not be high while reading 24-bit data in dump mode; otherwise, the AD7732 will be reset.

Figure 18 shows the digital interface signals executing a single conversion on Channel 0, waiting for the $\overline{\text{RDY}}$ pin to go low, and reading the Channel 0 status register and data register in the dump mode.

Continuous Conversion Mode

When the mode register is being written, the ADC status byte is cleared and the $\overline{\text{RDY}}$ pin goes high, regardless of its previous state. When the continuous conversion command is written to the mode register, the ADC starts conversion on the channel selected by the address of the mode register.

After the conversion is complete, the relevant channel data register and channel status register are updated, the relevant $\overline{\text{RDY}}$ bit in the ADC status register is set, and the AD7732 continues converting on the next enabled channel. The part will cycle through all enabled channels until put into another mode or reset. The cycle period will be the sum of all enabled channels' conversion times, set by the corresponding channel conversion time registers.

The $\overline{\text{RDY}}$ bit is reset when the relevant channel data register is being read. The behavior of the $\overline{\text{RDY}}$ pin depends on the $\overline{\text{RDYFN}}$ bit in the I/O port register. When the $\overline{\text{RDYFN}}$ bit is 0, the $\overline{\text{RDY}}$ pin goes low when any channel has unread data. When the $\overline{\text{RDYFN}}$ bit is set to 1, the $\overline{\text{RDY}}$ pin will only go low if all enabled channels have unread data.

If an ADC conversion result has not been read before a new ADC conversion is completed, the new result will overwrite the previous one. The relevant $\overline{\text{RDY}}$ bit goes low and the $\overline{\text{RDY}}$ pin goes high for at least 163 MCLK cycles (~26.5 μs), indicating when the data register is updated and the previous conversion data is lost.

If the data register is being read as an ADC conversion completes, the data register will not be updated with the new result (to avoid data corruption) and the new conversion data is lost.

Figure 19 shows the digital interface signal's sequence for the continuous conversion mode with Channels 0 and 1 enabled and the $\overline{\text{RDYFN}}$ bit set to 0. The $\overline{\text{RDY}}$ pin goes low and the data register is read after each conversion. Figure 20 shows a similar sequence but with the $\overline{\text{RDYFN}}$ bit set to 1. The $\overline{\text{RDY}}$ pin goes low and all data registers are read after all conversions are completed. Figure 21 shows the $\overline{\text{RDY}}$ pin when no data are read from the AD7732.

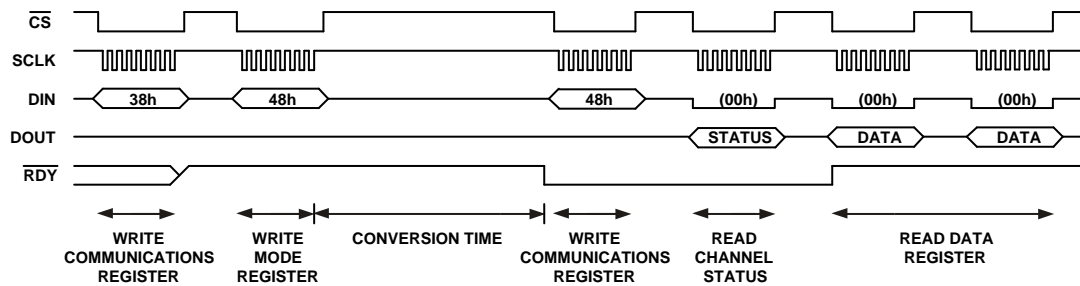

Figure 18. Serial Interface Signals—Single Conversion Command, 16-Bits Data Reading, Dump Mode

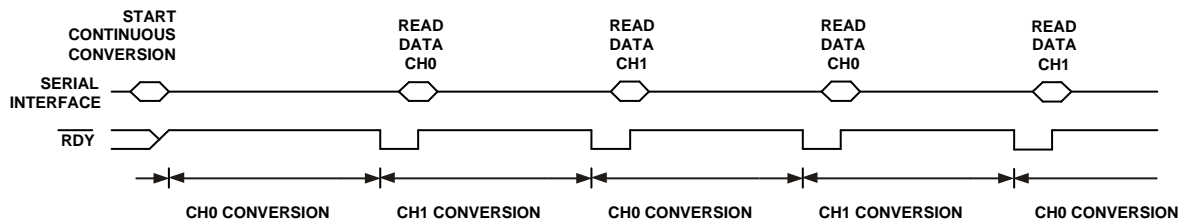

Figure 19. Continuous Conversion, CH0 and CH1, $\overline{\text{RDYFN}} = 0$

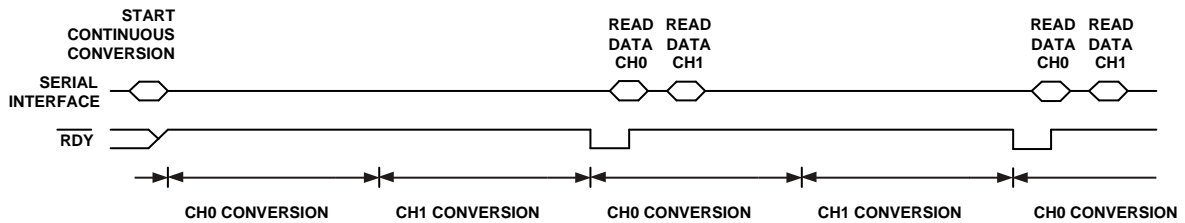

Figure 20. Continuous Conversion, CH0 and CH1, RDYFN = 1

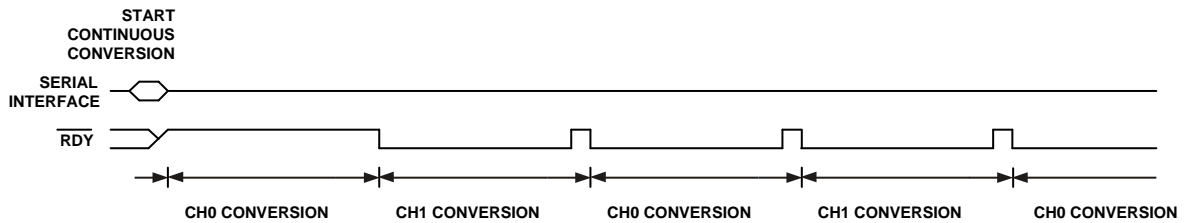

Figure 21. Continuous Conversion, CH0 and CH1, No Data Read

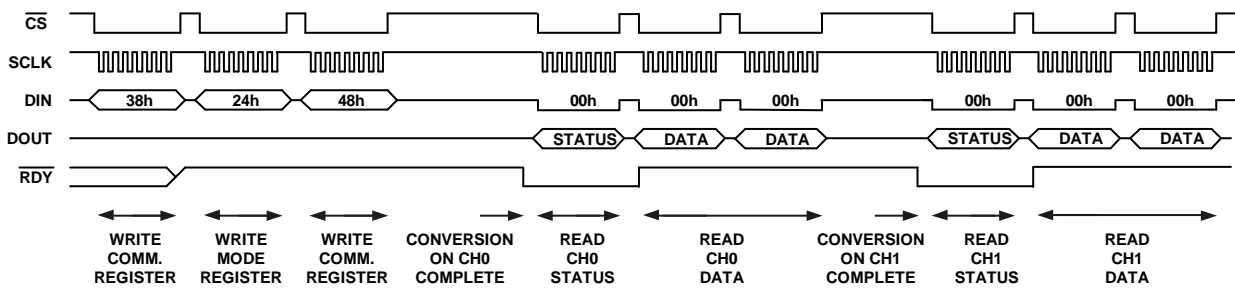

Figure 22. Continuous Conversion, CH0 and CH1, Continuous Read

Continuous Read (Continuous Conversion) Mode

When the Cont RD bit in the mode register is set, the first write of 48h to the communications register starts the continuous read mode. As shown in Figure 22, subsequent accesses to the part sequentially read the channel status and data registers of the last completed conversion without any further configuration of the communications register being required.

Note that the continuous conversion bit in the mode register should be set when entering the continuous read mode.

Note that the continuous read mode is a dump mode reading of the channel status and data registers regardless of the dump bit value. Use the channel bits in the channel status register to check/recognize that channel data is actually being shifted out.

Note that the last completed conversion result is being read. Therefore the RDYFN bit in the I/O port register should be 0

and reading the result should always start before the next conversion is completed.

The AD7732 will stay in continuous read mode as long as the DIN pin is low while the \overline{CS} pin is low; therefore, write 0 to the AD7732 while reading in continuous read mode. To exit continuous read mode, take the DIN pin high for at least 100 ns after a read is complete. (Write 80h to the AD7732 to exit continuous reading.)

Taking the DIN pin high does not change the Cont RD bit in the mode register. Therefore, the next write of 48h starts the continuous read mode again. To completely stop the continuous read mode, write to the mode register to clear the Cont RD bit.

CIRCUIT DESCRIPTION

The AD7732 is a sigma-delta ADC that is intended for the measurement of wide dynamic range, low frequency signals in industrial process control, instrumentation, and PLC systems.

It contains thin film resistor dividers, a multiplexer, an input buffer, a sigma-delta (or charge balancing) ADC, a digital filter, a clock oscillator, a digital I/O port, and a serial communications interface.

Analog Front End

The AD7732 features two fully differential analog inputs. The on-chip thin film resistor dividers allow ± 10 V, ± 5 V, 0 V to $+10$ V, and 0 V to $+5$ V input signals to be connected directly to the analog input pins.

The resistor divider input stage is followed by the multiplexer and then by a wide bandwidth, fast settling time differential input buffer capable of driving the dynamic load of a high speed sigma-delta modulator.

In normal circuit configuration, the BIAS pins are connected to the 2.5 V (reference) voltage source. This ensures that the differential signal seen by the internal input buffer is within its absolute/common-mode range of $AGND + 200$ mV to $AV_{DD} - 300$ mV.

The AD7732 AIN differential voltage should be within the specified nominal (up to ± 10 V) input range, otherwise the performance on channel might degrade (see the Analog Input's Extended Voltage Range section).

The AD7732 INL performance varies with the AIN common-mode voltage (Figure 9). The differential analog input voltage of ± 10 V with a common-mode voltage of 0 V means that the AIN differential voltage is centered around $AGND$ and both $AIN(+)$ and $AIN(-)$ change within ± 5 V respect to $AGND$. The AD7732 INL also varies with the MCLK frequency (Figure 7).

If the BIAS pins are in normal configuration, the AIN pin absolute voltage up to ± 16.5 V does not degrade the adjacent channel's performance. An AIN absolute voltage over ± 16.5 V results in current flowing through the internal protection diodes located behind the thin film resistors; the adjacent channel can be affected. By configuring the BIAS and RA to RD pins differently, the part will work with higher AIN absolute voltages as long as the internal voltage seen by the multiplexer and input buffer is within 200 mV to $AV_{DD} - 300$ mV. Absolute voltage for the AIN, BIAS, and RA to RD pins must never exceed the values specified in the Absolute Maximum Ratings.

Note that the OVR bit in the channel status register is generated digitally from the conversion result and indicates the sigma-delta modulator (nominal) overrange. The OVR bit DOES NOT indicate exceeding the AIN pin absolute/common-mode voltage limits.

Figure 23 shows the AD7732 analog input internal structure.

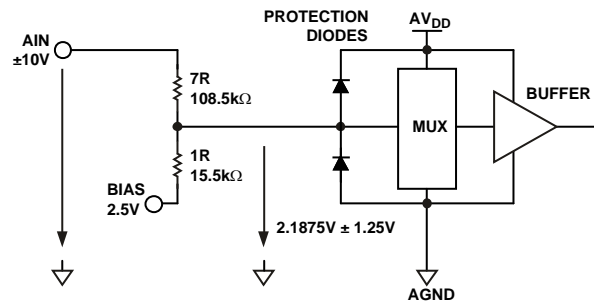

Figure 23. Simplified Analog Input Internal Structure

Analog Input's Extended Voltage Range

The AD7732 output data code span corresponds to the nominal input voltage range. The ADC is functional outside the nominal input voltage range, but the performance might degrade. The sigma-delta modulator was designed to fully cover a ± 11.6 V differential input voltage; outside this range, the performance might degrade more rapidly. The adjacent channels are not affected by up to ± 16.5 V absolute analog input voltage (Figure 8).

When the CLAMP bit in the mode register is set to 1, the channel data register will be digitally clamped to either all 0s or all 1s when the analog input voltage goes outside the nominal input voltage range.

As shown in Table 16 and Table 17, when CLAMP = 0, the data reflects the analog input voltage outside the nominal voltage range. In this case, the SIGN and OVR bits in the channel status register should be considered along with the data register value to decode the actual conversion result.

Note that the OVR bit in the channel status register is generated digitally from the conversion result and indicates the sigma-delta modulator (nominal) overrange. The OVR bit DOES NOT indicate exceeding the AIN pin's absolute voltage limits.

Table 16. Extended Input Voltage Range, Nominal Voltage Range ± 10 V, 16 Bits, CLAMP = 0

Input (V)	Data (hex)	SIGN	OVR
11.60039	147B	0	1
10.00061	0001	0	1
10.00031	0000	0	1
10.00000	FFFF	0	0
0.00031	8001	0	0
0.00000	8000	0	0
-0.00031	7FFF	1	0
-10.00000	0000	1	0
-10.00031	FFFF	1	1
-10.00061	FFFE	1	1
-11.60040	EB85	1	1

Table 17. Extended Input Voltage Range, Nominal Voltage Range 0 V to +10 V, 16 Bits, CLAMP = 0

Input (V)	Data (hex)	SIGN	OVR
11.60006	28F5	0	1
10.00031	0001	0	1
10.00015	0000	0	1
10.00000	FFFF	0	0
0.00015	0001	0	0
0.00000	0000	0	0
-0.00015	0000	1	1

Chopping

With chopping enabled, the multiplexer repeatedly reverses the ADC inputs. Every output data result is then calculated as an average of two conversions, the first with the positive and the second with the negative offset term included. This effectively removes any offset error of the input buffer and sigma-delta modulator.

However, chopping is applied only behind the input resistor divider stage; therefore, chopping does not eliminate the offset error and drifts caused by the resistors. Figure 24 shows the channel signal chain with chopping enabled.

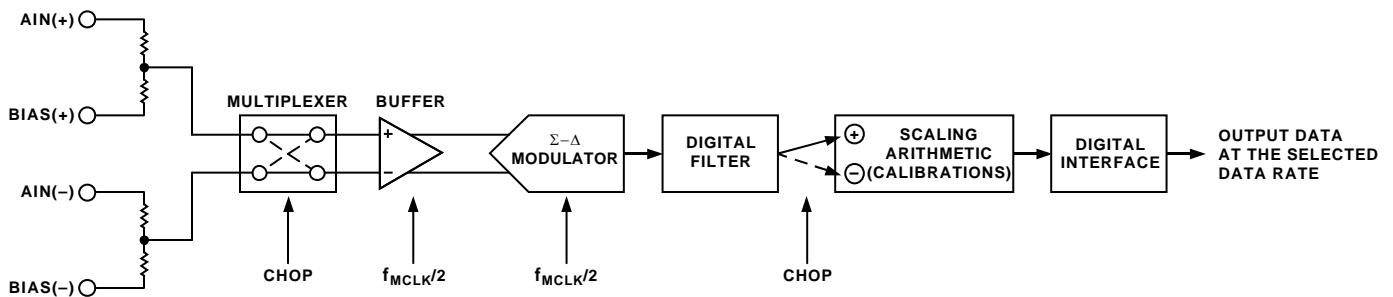

Figure 24. Channel Signal Chain Diagram with Chopping Enabled

Multiplexer, Conversion, and Data Output Timing

The specified conversion time includes one or two settling and sampling periods and a scaling time.

With chopping enabled (Figure 25), a conversion cycle starts with a settling time of 43 MCLK cycles or 44 MCLK cycles (~7 μ s with a 6.144 MHz MCLK) to allow the circuits following the multiplexer to settle. The sigma-delta modulator then samples the analog signals and the digital filter processes the digital data stream. The sampling time depends on FW, i.e., on the channel conversion time register contents. After another settling of 42 MCLK cycles (~6.8 μ s), the sampling time is repeated with a reversed (chopped) analog input signal. Then, during the scaling time of 163 MCLK cycles (~26.5 μ s), the two results from the digital filter are averaged, scaled using the calibration registers, and written into the channel data register.

With chopping disabled (Figure 26), there is only one sampling time preceded by a settling time of 43 MCLK cycles or 44 MCLK cycles and followed by a scaling time of 163 MCLK cycles.

The $\overline{\text{RDY}}$ pin goes high during the scaling time, regardless of its previous state. The relevant RDY bit is set in the ADC status register and in the channel status register, and the $\overline{\text{RDY}}$ pin goes low when the channel data register is updated and the channel conversion cycle is finished. If in continuous conversion mode, the part will automatically continue with a conversion cycle on the next enabled channel.

Note that every channel can be configured independently for conversion time and chopping mode. The overall cycle and effective per channel data rates depend on all enabled channel settings.

Sigma-Delta ADC

The AD7732 core consists of a charge balancing sigma-delta modulator and a digital filter. The architecture is optimized for fast, fully settled conversion. This allows for fast channel-to-channel switching while maintaining inherently excellent linearity, high resolution, and low noise.

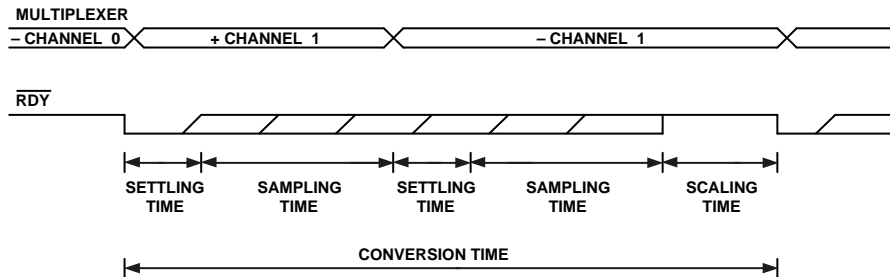

Figure 25. Multiplexer and Conversion Timing—Continuous Conversion on Several Channels with Chopping Enabled

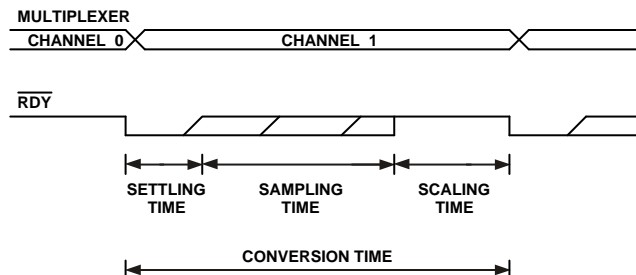

Figure 26. Multiplexer and Conversion Timing—Continuous Conversion on Several Channels with Chopping Disabled

Frequency Response

The sigma-delta modulator runs at $\frac{1}{2}$ the MCLK frequency, which is effectively the sampling frequency. Therefore, the Nyquist frequency is $\frac{1}{4}$ the MCLK frequency. The digital filter, in association with the modulator, features the frequency response of a first order low-pass filter. The -3 dB point is close to the frequency of $1/\text{channel conversion time}$. The roll-off is -20 dB/dec up to the Nyquist frequency. If chopping is enabled, the input signal is resampled by chopping. Therefore, the overall frequency response features notches close to the frequency of $1/\text{channel conversion time}$. The top envelope is again the ADC response of -20 dB/dec.

The typical frequency response plots are given in Figure 27 and Figure 28. The plots are normalized to $1/\text{channel conversion time}$.

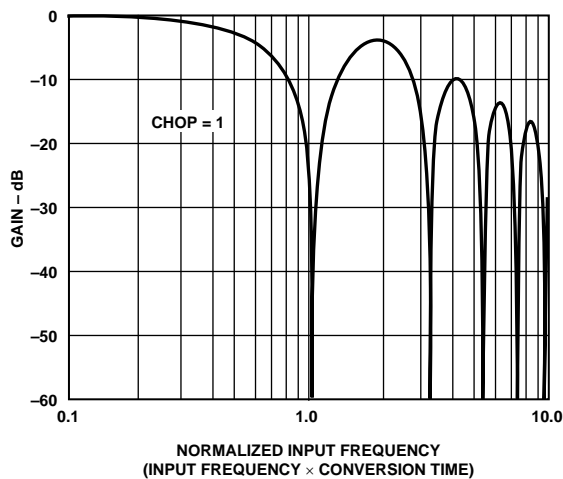

Figure 27. Typical ADC Frequency Response, Chopping Enabled

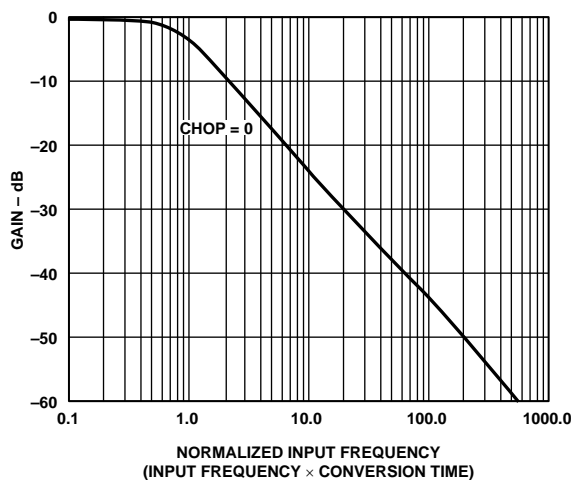

Figure 28. Typical ADC Frequency Response, Chopping Disabled

Voltage Reference Inputs

The AD7732 has a differential reference input, REF IN(+) and REF IN(-). The common-mode range for these inputs is from AGND to AV_{DD} . The nominal differential reference voltage for specified operation is 2.5 V. Both reference inputs feature dynamic load. Therefore, the reference inputs should be connected to a low impedance reference voltage source. External resistance/capacitance combinations may result in gain errors on the part.

The output noise performance outlined in Table 4 through Table 9 is for an analog input of 0 V and is unaffected by noise on the reference. To obtain the same noise performance as shown in the noise tables over the full input range requires a low noise reference source for the AD7732. If the reference noise in the bandwidth of interest is excessive, it will degrade the performance of the AD7732.

Recommended reference voltage sources for the AD7732 include the AD780, ADR421, REF43, and REF192. Note that in a typical connection, the voltage reference must be capable of sinking current flowing out of the BIAS pins through the internal resistors if a positive voltage is applied to the analog input. The AD780 meets this requirement. If the voltage reference used in an application is not capable of sinking current, an external resistor ($5\text{ k}\Omega$) should be connected in parallel to the REFIN pins.

Reference Detect

The AD7732 includes on-chip circuitry to detect if the part has a valid reference for conversions. If the voltage between the REFIN(+) and REFIN(-) pins goes below the NOREF trigger voltage (0.5 V typ) and the AD7732 is performing a conversion, the NOREF bit in the channel status register is set.

I/O Port

The AD7732 P0 pin can be used as a general-purpose digital I/O pin. The P1 pin (SYNC/P1) can be used as a general-purpose digital I/O pin or to synchronize the AD7732 with other devices in the system. When the SYNC bit in the I/O port register is set and the SYNC pin is low, the AD7732 does not process any conversion. If it is put into single conversion mode, continuous conversion mode, or any calibration mode, the AD7732 waits until the SYNC pin goes high and then starts operation. This allows conversion to start from a known point in time, i.e., the rising edge of the SYNC pin.

The digital P0 and P1 voltage is referenced to the analog supplies. When configured as inputs, the pins should be tied high or low.

Calibration

The AD7732 provides zero-scale self-calibration and zero- and full-scale system calibration capability that can effectively reduce the offset error and gain error to the order of the noise. After each conversion, the ADC conversion result is scaled using the ADC calibration registers and the relevant channel calibration registers before being written to the data register.

For unipolar ranges:

$$\text{Data} = ((\text{ADC result} - \text{ADC ZS Cal. reg.}) \\ \times \text{ADC FS Reg./200000h} - \text{Ch. ZS Cal. reg.}) \\ \times \text{Ch. FS Cal. reg./200000h}$$

For bipolar ranges:

$$\text{Data} = ((\text{ADC result} - \text{ADC ZS Cal. reg.}) \\ \times \text{ADC FS Reg./400000h} + 800000h - \text{Ch. ZS Cal. reg.}) \\ \times \text{Ch. FS Cal. reg./200000h}$$

Where the ADC result is in the range of 0 to FFFFFFFh.

Note that the channel zero-scale calibration register has the format of a sign bit and a 22-bit channel offset value. It is strongly recommended that the user not change the ADC full-scale register.

To start any calibration, write the relevant mode bits to the AD7732 mode register. After the calibration is complete, the contents of the corresponding calibration registers are updated, all RDY bits in the ADC status register are set, the RDY pin

goes low, and the AD7732 reverts to idle mode. The calibration duration is the same as the conversion time configured on the selected channel. A longer conversion time gives less noise and yields a more exact calibration; therefore, use at least the default conversion time to initiate any calibration.

ADC Zero-Scale Self-Calibration

The ADC zero-scale self-calibration can reduce the offset error in the chopping disabled mode. If repeated after a temperature change, it can also reduce the offset drift error in the chopping disabled mode.

The zero-scale self-calibration is performed on internally shorted ADC inputs. The negative analog input terminal on the selected channel is used to set the ADC zero-scale calibration common mode. Therefore, either the negative terminal of the selected differential pair or the AINCOM on the single-ended channel configuration should be driven to a proper common-mode voltage.

It is strongly recommended that the ADC zero-scale calibration register should only be updated as part of a zero-scale self-calibration.

Per Channel System Calibration

If the per channel system calibrations are used, these should be initiated in the following order: a channel zero-scale system calibration, followed by a channel full-scale system calibration.

The system calibration is affected by the ADC zero-scale and full-scale calibration registers. Therefore, if both self-calibration and system calibration are used in the system, an ADC full-scale self-calibration should be performed first, followed by a system calibration cycle.

While executing a system calibration, the fully settled system zero-scale voltage signal or system full-scale voltage signal must be connected to the selected channel analog inputs.

The per channel calibration registers can be read, stored, or modified and written back to the AD7732. Note that when writing the calibration registers the AD7732 must be in idle mode. Note that outside the specified calibration range, calibration is possible but the performance may degrade (see the System Calibration section in Table 1).

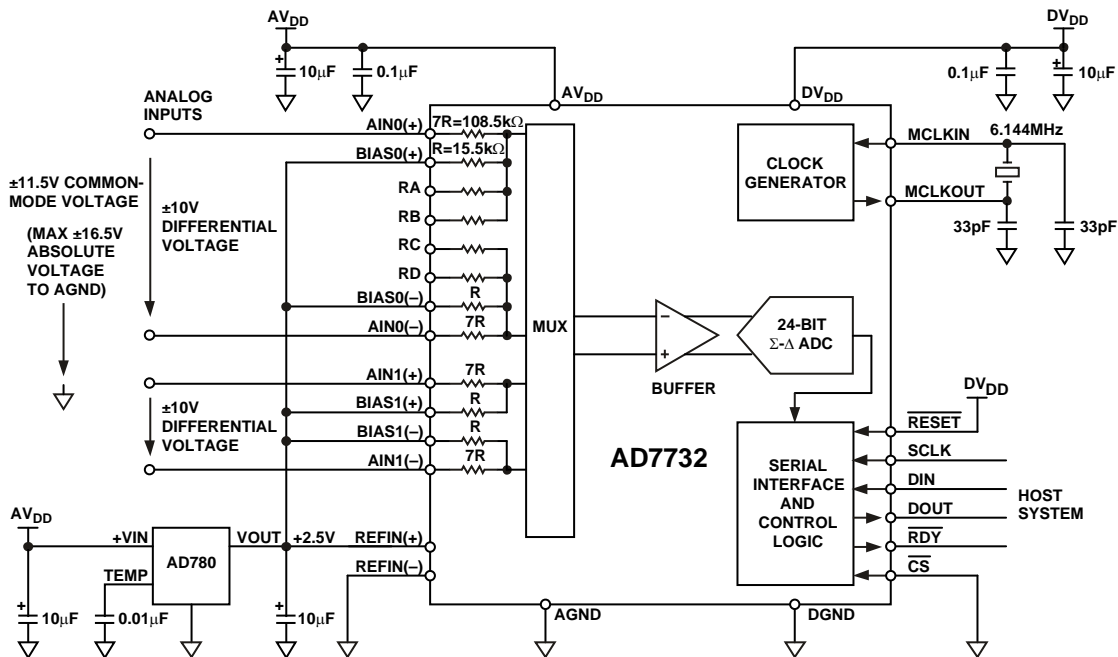

Figure 29. Typical Connections for the AD7732 Application

High Common-Mode Voltage Application

Using additional thin film resistors on AIN0 and an external operational amplifier with a $\pm 15\text{ V}$ power supply, the AD7732 AIN0 can easily be configured to accept high common-mode voltages.

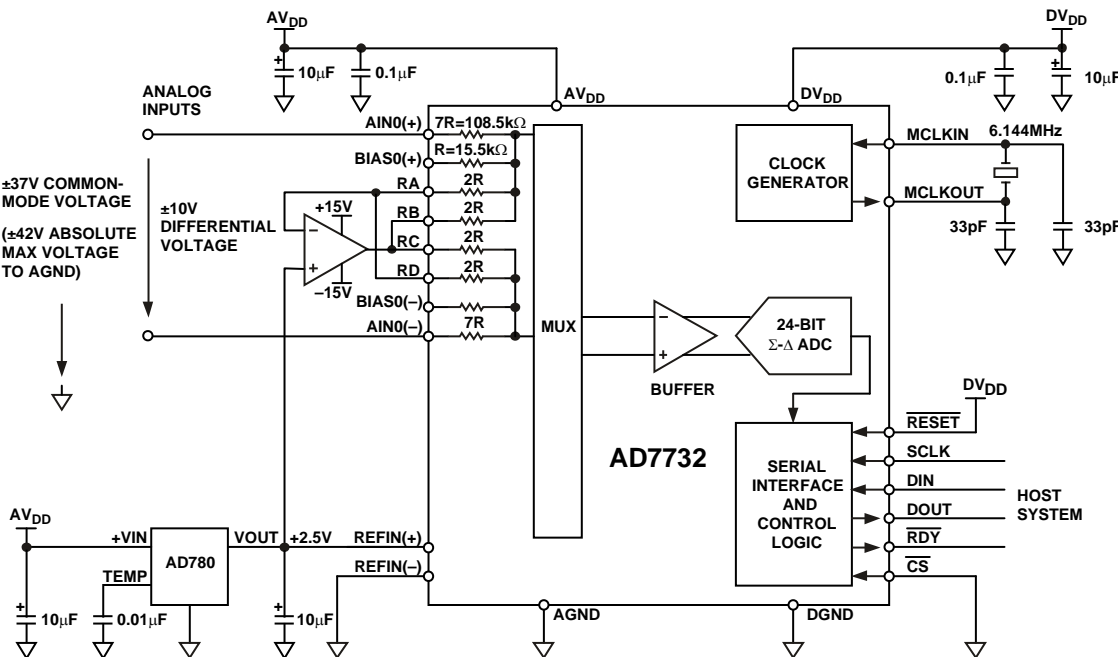
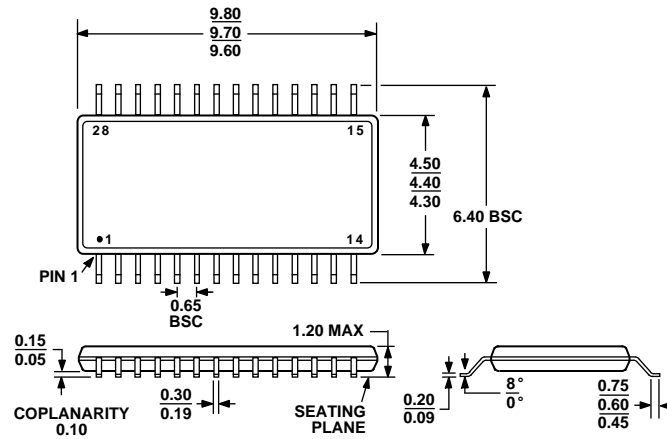

Figure 30. High Common-Mode Voltage Application

OUTLINE DIMENSIONS



COMPLIANT TO JEDEC STANDARDS MO-153-AE

Figure 31. 28-Lead Thin Shrink Small Outline Package [TSSOP] (RU-28)

Dimensions shown in millimeters

Ordering Guide

Model ¹	Temperature Range	Package Description	Package Option
AD7732BRU	-40°C to +105°C	28-Lead Thin Shrink Small Outline Package [TSSOP]	RU-28
AD7732BRUZ	-40°C to +105°C	28-Lead Thin Shrink Small Outline Package [TSSOP]	RU-28
AD7732BRUZ-REEL	-40°C to +105°C	28-Lead Thin Shrink Small Outline Package [TSSOP]	RU-28
AD7732BRUZ-REEL7	-40°C to +105°C	28-Lead Thin Shrink Small Outline Package [TSSOP]	RU-28
EVAL-AD7732EBZ		Evaluation Board	

¹ Z = RoHS Compliant Part.

Looking for pricing, stock, or lifecycle information?

Click below to explore more details on WIN SOURCE:

 [View AD7732BRUZ on WIN SOURCE](#)

 [Analog Devices Inc. Information](#)

Optimize Your Supply Chain with WIN SOURCE Solutions

-  Global Sourcing Solution
-  Obsolete Management
-  Cost Control Management
-  Shortage Management
-  Alternative Solution
-  Excess Inventory Management