



THE DATASHEET OF STW14NM50





STW14NM50

N-CHANNEL 550V @ Tjmax - 0.32Ω - 14A TO-247

MDmesh™ MOSFET

Table 1: General Features

TYPE	V _{DSS} (@Tjmax)	R _{DS(on)}	I _D
STW14NM50	550 V	< 0.35 Ω	14 A

- TYPICAL R_{DS(on)} = 0.32 Ω
- HIGH dv/dt AND AVALANCHE CAPABILITIES
- 100% AVALANCHE RATED
- LOW INPUT CAPACITANCE AND GATE CHARGE
- LOW GATE INPUT RESISTANCE
- TIGHT PROCESS CONTROL AND HIGH MANUFACTURING YIELDS

DESCRIPTION

The MDmesh™ is a new revolutionary MOSFET technology that associates the Multiple Drain process with the Company's PowerMESH™ horizontal layout. The resulting product has an outstanding low on-resistance, impressively high dv/dt and excellent avalanche characteristics. The adoption of the Company's proprietary strip technique yields overall dynamic performance that is significantly better than that of similar competition's products.

APPLICATIONS

The MDmesh™ family is very suitable for increase the power density of high voltage converters allowing system miniaturization and higher efficiencies.

Table 2: Order Codes

SALES TYPE	MARKING	PACKAGE	PACKAGING
STW14NM50	W14NM50	TO-247	TUBE

Figure 1: Package

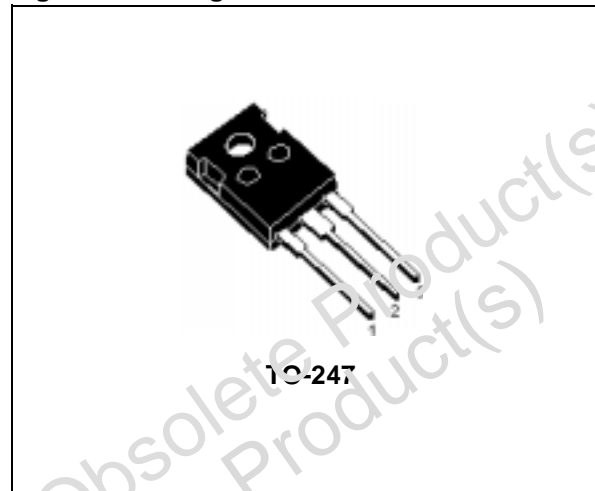
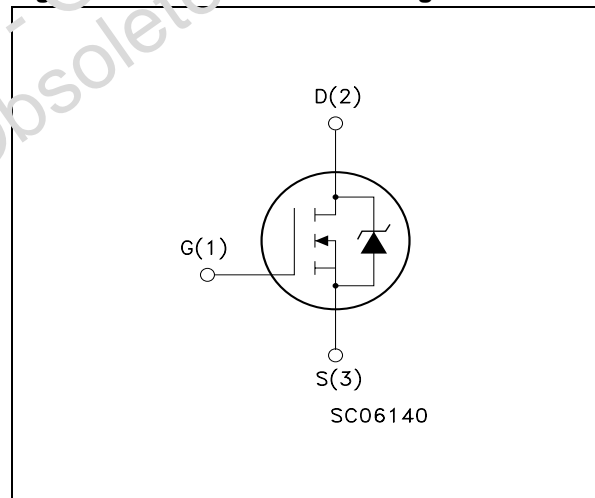

Figure 2: Internal Schematic Diagram



STW14NM50

Table 3: Absolute Maximum ratings

Symbol	Parameter	Value	Unit
V _{GS}	Gate- source Voltage	±30	V
I _D	Drain Current (continuous) at T _C = 25°C	14	A
I _D	Drain Current (continuous) at T _C = 100°C	8.8	A
I _{DM} ⁽¹⁾	Drain Current (pulsed)	56	A
P _{TOT}	Total Dissipation at T _C = 25°C	175	W
	Derating Factor	1.28	W/°C
dv/dt	Peak Diode Recovery voltage slope	6	V/ns
T _{stg}	Storage Temperature	-65 to 150	°C
T _j	Max. Operating Junction Temperature	150	°C

(*)Pulse width limited by safe operating area

(*)Limited only by maximum temperature allowed

(1) I_{SD} ≤ 14A, di/dt ≤ 100A/μs, V_{DD} ≤ V_{(BR)DSS}, T_j ≤ T_{JMAX}.

Table 4: Thermal Data

R _{thj-case}	Thermal Resistance Junction-case Max	0.715	°C/W
R _{thj-amb}	Thermal Resistance Junction-ambient Max	33	°C/W
T _l	Maximum Lead Temperature For Soldering Purpose	300	°C

Table 5: Avalanche Characteristics

Symbol	Parameter	Max Value	Unit
I _{AR}	Avalanche Current, Repetitive or Not-Repetitive (pulse width limited by T _j max)	12	A
E _{AS}	Single Pulse Avalanche Energy (starting T _j = 25 °C, I _D = I _{AR} , V _{DD} = 50 V)	400	mJ

ELECTRICAL CHARACTERISTICS (T_{CASE} = 25°C UNLESS OTHERWISE SPECIFIED)

Table 6: On /Off

Symbol	Parameter	Test Conditions	Min.	Typ.	Max.	Unit
V _{(BR)DSS}	Drain source Breakdown Voltage	I _D = 250 μA, V _{GS} = 0	500			V
I _{DSS}	Zero Gate Voltage Drain Current (V _{GS} = 0)	V _{DS} = Max Rating V _{DS} = Max Rating, T _C = 125°C			1 10	μA μA
I _{GSS}	Gate-body Leakage Current (V _{DS} = 0)	V _{GS} = ± 30 V			± 100	nA
V _{GS(th)}	Gate Threshold Voltage	V _{DS} = V _{GS} , I _D = 250 μA	3	4	5	V
R _{DS(on)}	Static Drain-source On Resistance	V _{GS} = 10 V, I _D = 6 A		0.32	0.35	Ω

ELECTRICAL CHARACTERISTICS (CONTINUED)

Table 7: Dynamic

Symbol	Parameter	Test Conditions	Min.	Typ.	Max.	Unit
g_{fs} (1)	Forward Transconductance	$V_{DS} > I_{D(on)} \times R_{DS(on)max}$, $I_D = 6A$		5.2		S
C_{iss} C_{oss} C_{rss}	Input Capacitance Output Capacitance Reverse Transfer Capacitance	$V_{DS} = 25 V$, $f = 1 MHz$, $V_{GS} = 0$		1000 180 25		pF pF pF
$C_{OSS eq}$ (3)	Equivalent Output Capacitance	$V_{GS} = 0 V$, $V_{DS} = 0$ to $400 V$		90		pF
R_G	Gate Input Resistance	$f=1 MHz$ Gate DC Bias = 0 Test Signal Level = 20mV Open Drain		1.6		Ω
$t_{d(on)}$ t_r $t_{d(off)}$ t_f	Turn-on Delay Time Rise Time Turn-off-Delay Time Fall Time	$V_{DD} = 250 V$, $I_D = 6 A$, $R_G = 4.7 \Omega$, $V_{GS} = 10 V$ (see Figure 15)		20 10 19 8		ns ns ns ns
Q_g Q_{gs} Q_{gd}	Total Gate Charge Gate-Source Charge Gate-Drain Charge	$V_{DD} = 400 V$, $I_D = 12 A$, $V_{GS} = 10 V$ (see Figure 18)		28 8 15	38	nC nC nC

Table 8: Source Drain Diode

Symbol	Parameter	Test Conditions	Min.	Typ.	Max.	Unit
I_{SD} I_{SDM} (2)	Source-drain Current Source-drain Current (pulsed)				14 56	A A
V_{SD} (1)	Forward On Voltage	$I_{SD} = 12 A$, $V_{GS} = 0$			1.5	V
t_{rr} Q_{rr} I_{RRM}	Reverse Recovery Time Reverse Recovery Charge Reverse Recovery Current	$I_{SD} = 12 A$, $di/dt = 100 A/\mu s$ $V_{DD} = 100V$ (see Figure 16)		270 2.23 16.5		ns μC A
t_{rr} Q_{rr} I_{RRM}	Reverse Recovery Time Reverse Recovery Charge Reverse Recovery Current	$I_{SD} = 12 A$, $di/dt = 100 A/\mu s$ $V_{DD} = 100V$, $T_j = 150^\circ C$ (see Figure 16)		340 3 18		ns μC A

(1) Pulsed: Pulse duration = 200 μs , duty cycle 1.5 %.

(2) Pulse width limited by safe operating area.

(3) $C_{OSS eq}$ is defined as a constant equivalent capacitance giving the same charging time as C_{OSS} when V_{DS} increases from 0 to 80% V_{DSS} .

Figure 3: Safe Operating Area

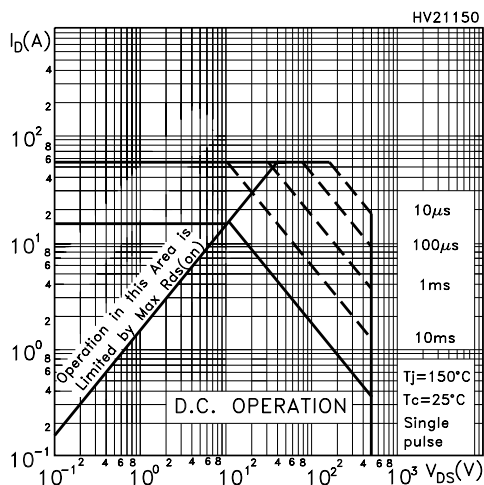

Figure 4: Output Characteristics

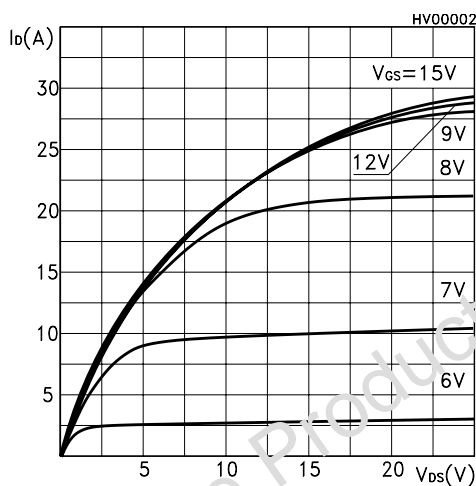

Figure 5: Transconductance

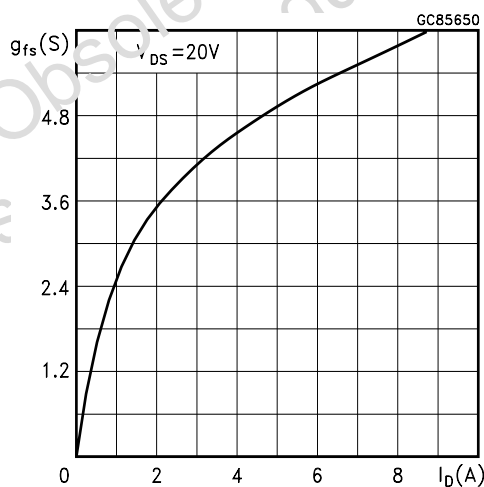

Figure 6: Thermal Impedance

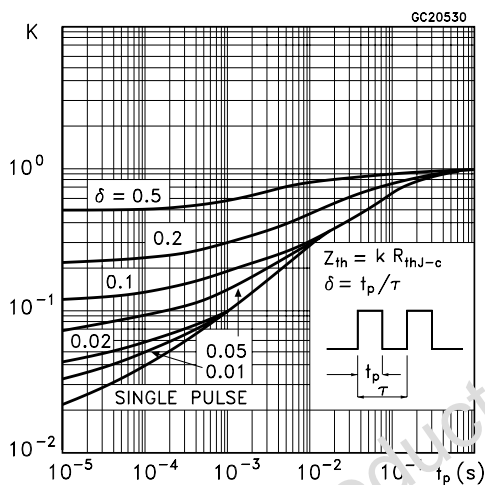

Figure 7: Transfer Characteristics

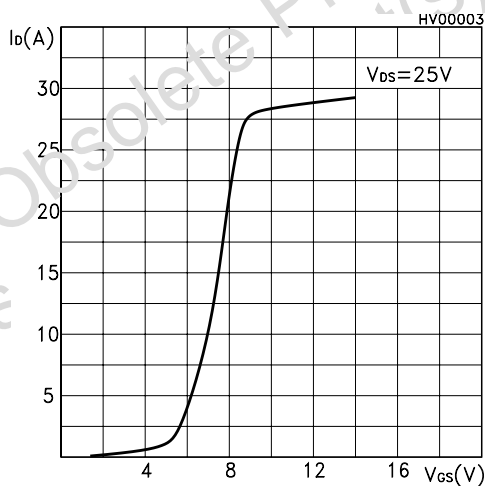

Figure 8: Static Drain-source On Resistance

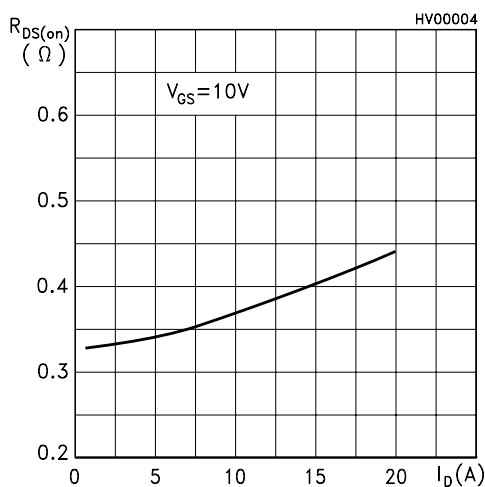

Figure 9: Gate Charge vs Gate-source Voltage

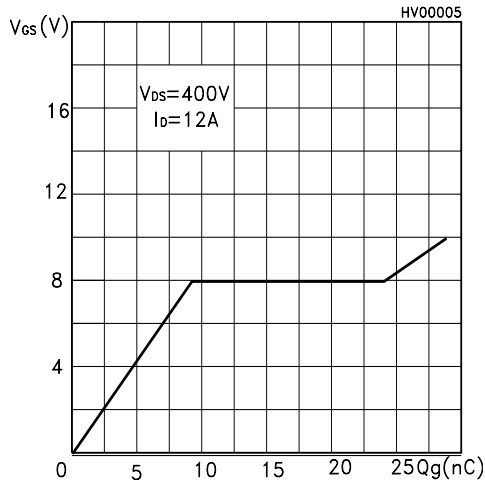

Figure 10: Normalized Gate Threshold Voltage vs Temperature

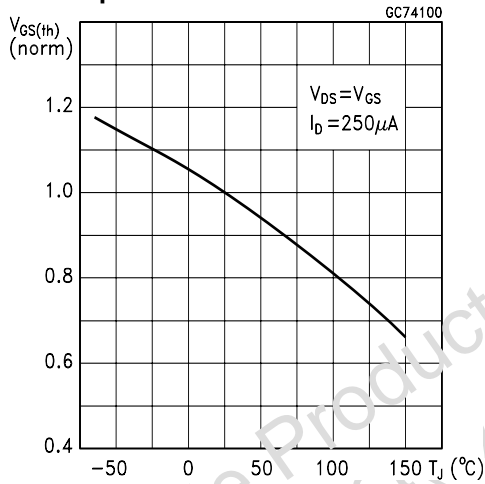

Figure 11: Dource-Drain Diode Forward Characteristics

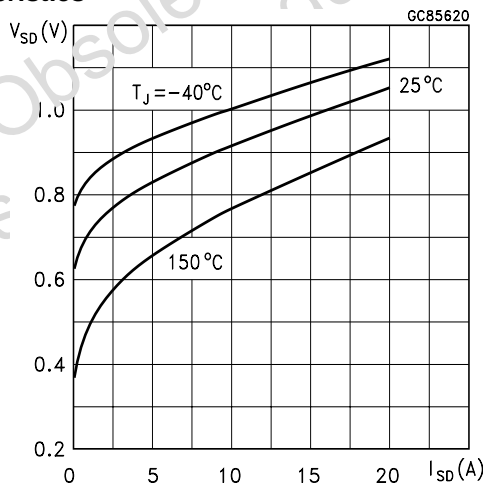

Figure 12: Capacitance Variations

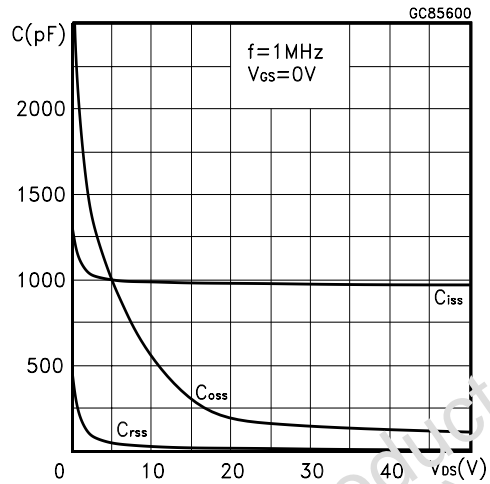

Figure 13: Normalized On Resistance vs Temperature

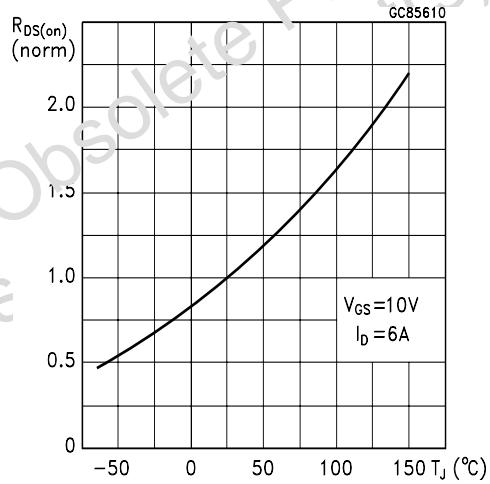

Figure 14: Unclamped Inductive Load Test Circuit

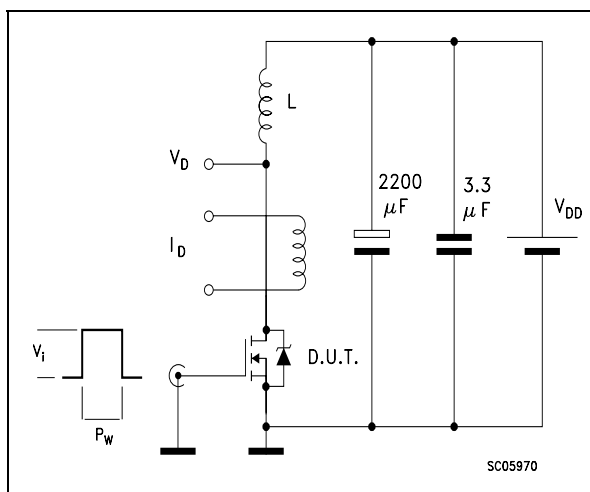

Figure 15: Switching Times Test Circuit For Resistive Load

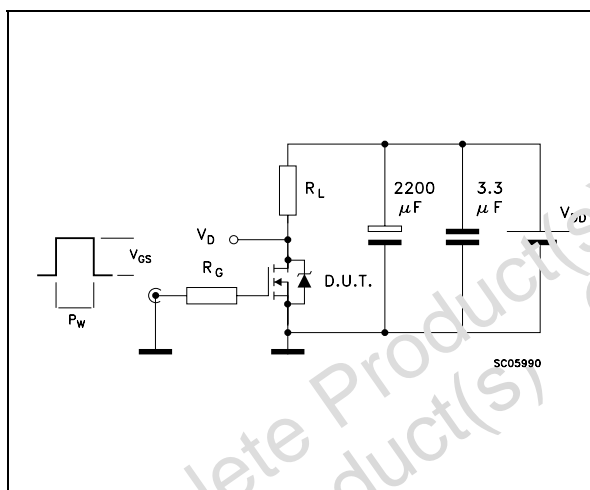

Figure 16: Test Circuit For Inductive Load Switching and Diode Recovery Times

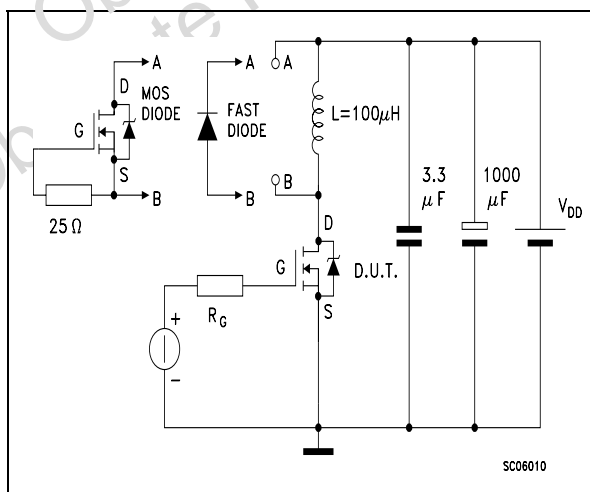

Figure 17: Unclamped Inductive Waferform

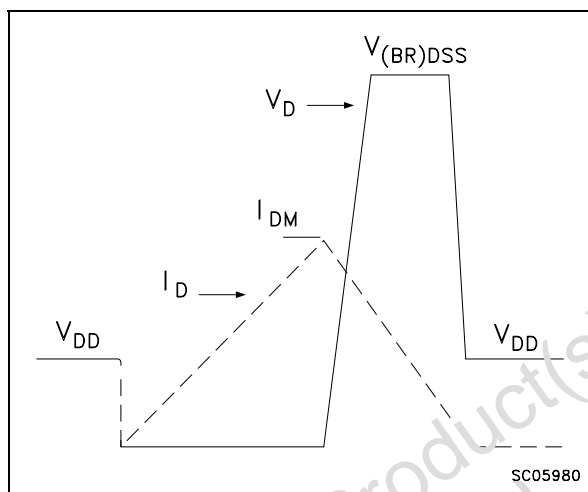
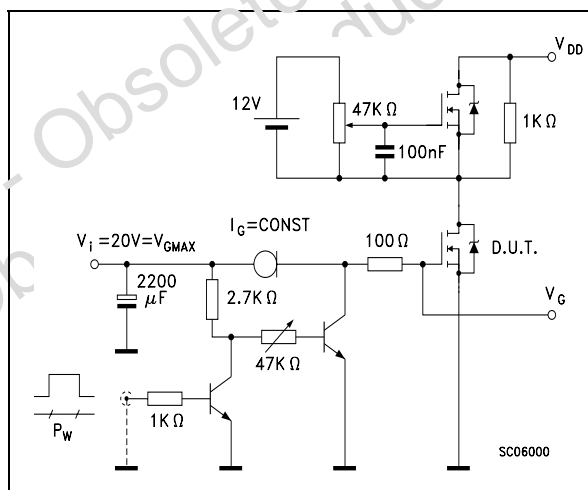

Figure 18: Gate Charge Test Circuit



TO-247 MECHANICAL DATA

DIM.	mm.			inch		
	MIN.	TYP.	MAX.	MIN.	TYP.	MAX.
A	4.85		5.15	0.19		0.20
A1	2.20		2.60	0.086		0.102
b	1.0		1.40	0.039		0.055
b1	2.0		2.40	0.079		0.094
b2	3.0		3.40	0.118		0.134
c	0.40		0.80	0.015		0.03
D	19.85		20.15	0.781		0.793
E	15.45		15.75	0.608		0.620
e		5.45			0.214	
L	14.20		14.80	0.560		0.582
L1	3.70		4.30	0.14		0.17
L2		18.50			0.728	
øP	3.55		3.65	0.140		0.143
øR	4.50		5.50	0.177		0.216
S		5.50			0.216	

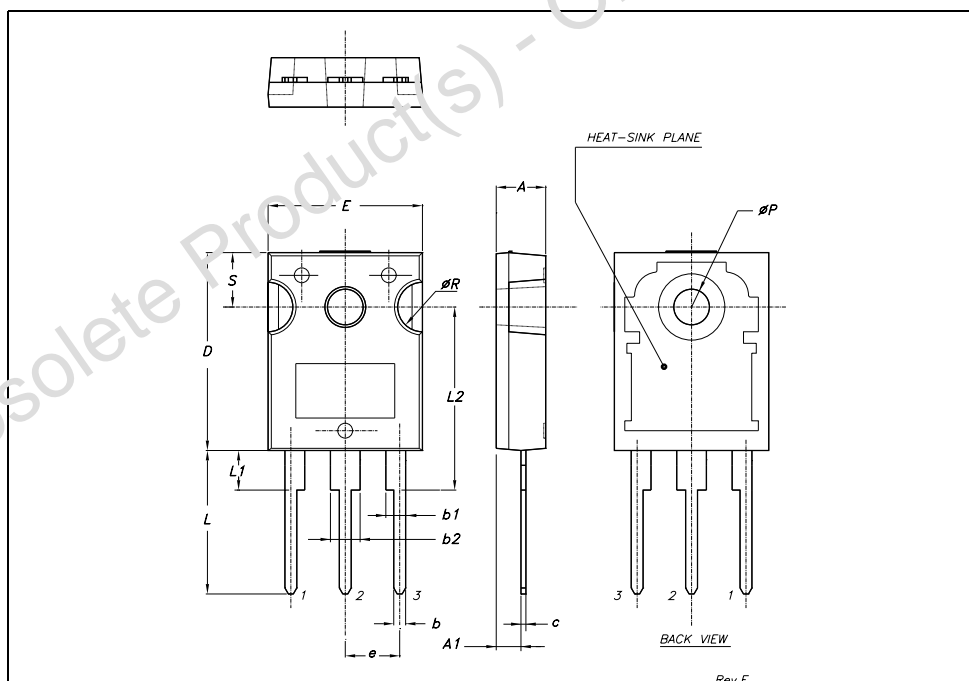

Table 9: Revision History

Date	Revision	Description of Changes
05-July-2004	5	The document change from "PRELIMINARY" to "COMPLETE". New Stylesheet.

Obsolete Product(s) - Obsolete Product(s)
Obsolete Product(s) - Obsolete Product(s)

Obsolete Product(s) - Obsolete Product(s)

Information furnished is believed to be accurate and reliable. However, STMicroelectronics assumes no responsibility for the consequences of use of such information nor for any infringement of patents or other rights of third parties which may result from its use. No license is granted by implication or otherwise under any patent or patent rights of STMicroelectronics. Specifications mentioned in this publication are subject to change without notice. This publication supersedes and replaces all information previously supplied. STMicroelectronics products are not authorized for use as critical components in life support devices or systems without express written approval of STMicroelectronics.



The ST logo is a registered trademark of STMicroelectronics
All other names are the property of their respective owners

© 2004 STMicroelectronics - All Rights Reserved
STMicroelectronics GROUP OF COMPANIES

Australia - Belgium - Brazil - Canada - China - Czech Republic - Finland - France - Germany - Hong Kong - India - Israel - Italy - Japan - Malaysia - Malta - Morocco - Singapore - Spain - Sweden - Switzerland - United Kingdom - United States.

Looking for pricing, stock, or lifecycle information?

Click below to explore more details on WIN SOURCE:

-  [View STW14NM50 on WIN SOURCE](#)
-  [STMicroelectronics Information](#)

Optimize Your Supply Chain with WIN SOURCE Solutions

-  Global Sourcing Solution
-  Obsolete Management
-  Cost Control Management
-  Shortage Management
-  Alternative Solution
-  Excess Inventory Management