



**THE DATASHEET OF  
MT93L16AQ1**



Zarlink has introduced a new generation family of AEC (ZL38002 and ZL38004). Zarlink recommends these products for new designs.

October 2006

## Features

- Contains two echo cancellers: 112 ms acoustic echo canceller + 16 ms line echo canceller
- Works with low cost voice codec. ITU-T G.711 or signed mag  $\mu$ /A-Law, or linear 2's comp
- Each port may operate in different format
- Advanced NLP design - full duplex speech with no switched loss on audio paths
- Fast re-convergence time: tracks changing echo environment quickly
- Adaptation algorithm converges even during Double-Talk
- Designed for exceptional performance in high background noise environments
- Provides protection against narrow-band signal divergence
- Howling prevention stops uncontrolled oscillation in high loop gain conditions
- Offset nulling of all PCM channels

### Ordering Information

MT93L16AQ	36 Pin QSOP	Tubes
MT93L16AF	48 Pin TQFP	Tubes
MT93L16AQ1	36 Pin QSOP*	Tubes

\*Pb Free Matte Tin

-40C to +85°C

- Serial micro-controller interface
- ST-BUS, GCI, or variable-rate SSI PCM interfaces
- User gain control provided for speaker path (-24 dB to +21 dB in 3 dB steps)
- AGC on speaker path
- Handles up to 0 dB acoustic echo return loss and 0 dB line ERL
- Transparent data transfer and mute options
- 20 MHz master clock operation
- Low power mode during PCM Bypass
- Bootloadable for future factory software upgrades
- 2.7 V to 3.6 V supply voltage; 5 V-tolerant inputs

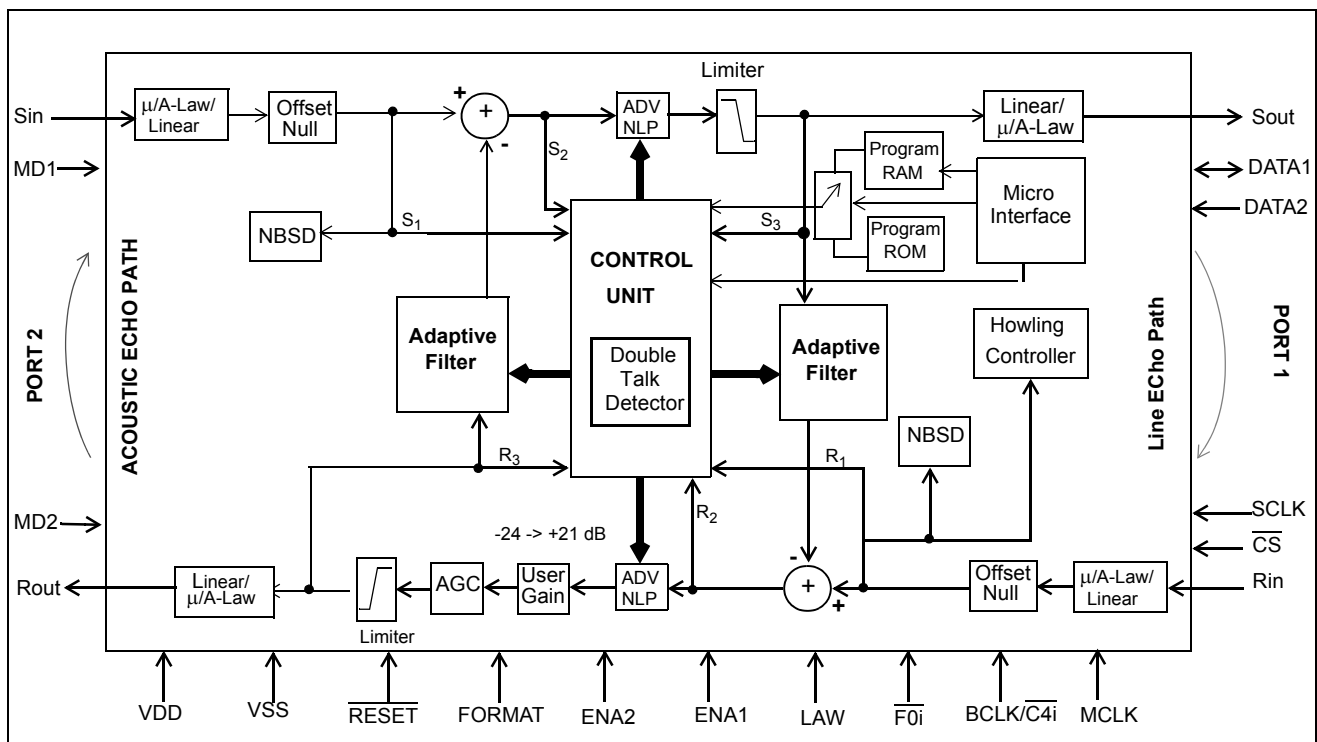

Figure 1 - Functional Block Diagram

**Applications**

- Full duplex speaker-phone for digital telephone
- Echo cancellation for video conferencing
- Hands-free in automobile environment
- Full duplex speaker-phone for PC

	<b>MT93L16</b>	<b>ZL38001</b>	<b>ZL38002</b>	<b>ZL38003</b>
<b>Description</b>	AEC for analog hands-free communication	AEC for analog hands-free communication	AEC with noise reduction for digital hands-free communication	AEC with noise reduction & codecs for digital hands-free communication
<b>Application</b>	Analog Desktop phone Analog Intercom	Analog Desktop phone Analog Intercom	Hands-free Car Kits Digital Desktop Phone Home Security Intercom & Pedestals	Hands-free Car Kits Digital Desktop Phone Home Security Intercom & Pedestals
<b>Features</b>				
AEC	1 channel	1 channel	1 channel	1 channel
LEC	1 channel	1 channel	Custom Load	Custom Load
Gains	User Gain	User Gain/18 dB Gain on Sout	User Gain + System tuning gains	User Gain + System tuning gains
Noise Reduction	N	N	Y	Y
Integrated Codecs	N	N	N	dual channel

**Table 1 - Acoustic Echo Cancellation Family**

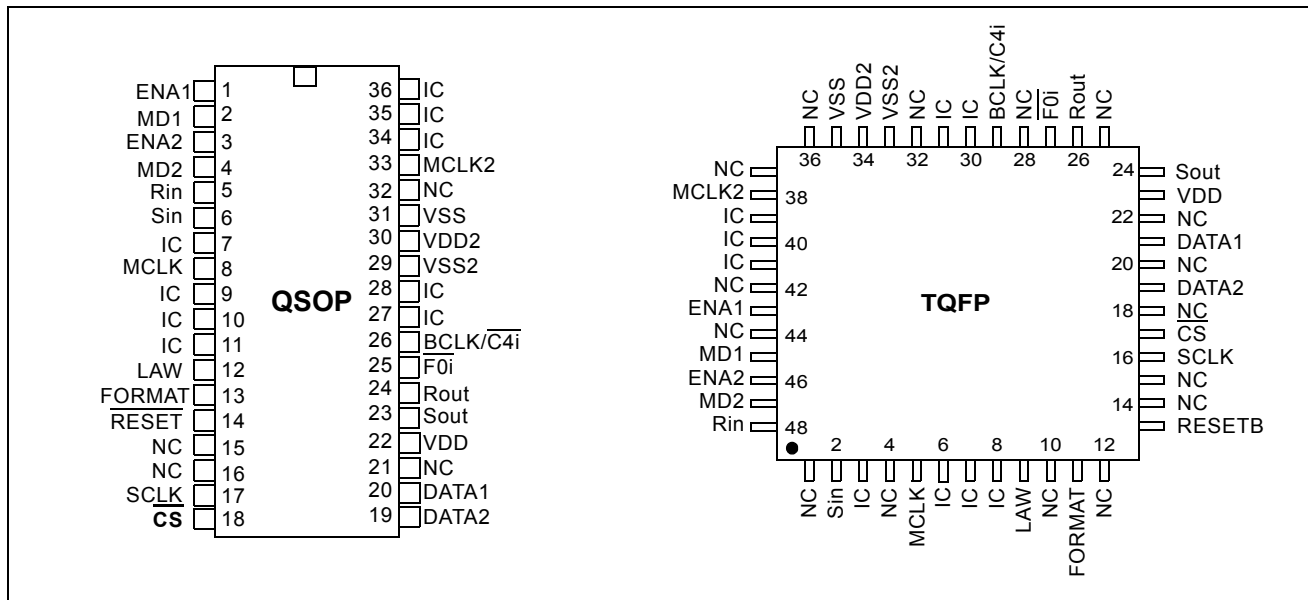

Figure 2 - Pin Connection

Pin Description

QSOP Pin #	TQFP Pin #	Name	Description
1	43	ENA1	<b>SSI Enable Strobe / ST-BUS &amp; GCI Mode for Rin/Sout (Input).</b> This pin has dual functions depending on whether SSI or ST-BUS/GCI is selected. For SSI, this strobe must be present for frame synchronization. This is an active high channel enable strobe, 8 or 16 data bits wide, enabling serial PCM data transfer for on Rin/Sout pins. Strobe period is 125 microseconds. For ST-BUS or GCI, this pin, in conjunction with the MD1 pin, selects the proper mode for Rin/Sout pins (see ST-BUS and GCI Operation description).
2	45	MD1	<b>ST-BUS &amp; GCI Mode for Rin/Sout (Input).</b> When in ST-BUS or GCI operation, this pin, in conjunction with the ENA1 pin, will select the proper mode for Rin/Sout pins (see ST-BUS and GCI Operation description). Connect this pin to Vss in SSI mode.
3	46	ENA2	<b>SSI Enable Strobe / ST-BUS &amp; GCI Mode for Sin/Rout (Input).</b> This pin has dual functions depending on whether SSI or ST-BUS/GCI is selected. For SSI, this is an active high channel enable strobe, 8 or 16 data bits wide, enabling serial PCM data transfer on Sin/Rout pins. Strobe period is 125 microseconds. For ST-BUS/GCI, this pin, in conjunction with the MD2 pin, selects the proper mode for Sin/Rout pins (see ST-BUS and GCI Operation description).
4	47	MD2	<b>ST-BUS &amp; GCI Mode for Sin/Rout (Input).</b> When in ST-BUS or GCI operation, this pin in conjunction with the ENA2 pin, selects the proper mode for Sin/Rout pins (see ST-BUS and GCI Operation description). Connect this pin to Vss in SSI mode.
5	48	Rin	<b>Receive PCM Signal Input (Input).</b> 128 kbit/s to 4096 kbit/s serial PCM input stream. Data may be in either companded or 2's complement linear format. This is the Receive Input channel from the line (or network) side. Data bits are clocked in following SSI, GCI or ST-BUS timing requirements.

## Pin Description (continued)

QSOP Pin #	TQFP Pin #	Name	Description
6	2	Sin	<b>Send PCM Signal Input (Input).</b> 128 kbit/s to 4096 kbit/s serial PCM input stream. Data may be in either companded or 2's complement linear format. This is the Send Input channel (from the microphone). Data bits are clocked in following SSI, GCI or ST-BUS timing requirements.
7	3	IC	<b>Internal Connection (Input):</b> Must be tied to Vss.
8	5	MCLK	<b>Master Clock (Input):</b> Nominal 20 MHz Master Clock input (may be asynchronous relative to 8 KHz frame signal.) Tie together with MCLK2 (pin 33).
9,10,11	6, 7, 8	IC	<b>Internal Connection (Input):</b> Must be tied to Vss.
12	9	LAW	<b>A<math>\overline{\mu}</math> Law Select (Input).</b> When low, selects $\mu$ -Law companded PCM. When high, selects A-Law companded PCM. This control is for both serial pcm ports.
13	11	FORMAT	<b>ITU-T/Sign Mag (Input).</b> When low, selects sign-magnitude PCM code. When high, selects ITU-T (G.711) PCM code. This control is for both serial pcm ports.
14	13	$\overline{\text{RESET}}$	<b>Reset / Power-down (Input).</b> An active low resets the device and puts the MT93L16 into a low-power stand-by mode.
17	16	SCLK	<b>Serial Port Synchronous Clock (Input).</b> Data clock for the serial microport interface.
18	17	$\overline{\text{CS}}$	<b>Serial Port Chip Select (Input).</b> Enables serial microport interface data transfers. Active low.
19	19	DATA2	<b>Serial Data Receive (Input).</b> In Motorola/National serial microport operation, the DATA2 pin is used for receiving data. In Intel serial microport operation, the DATA2 pin is not used and must be tied to Vss or Vdd.
20	21	DATA1	<b>Serial Data Port (Bidirectional).</b> In Motorola/National serial microport operation, the DATA1 pin is used for transmitting data. In Intel serial microport operation, the DATA1 pin is used for transmitting and receiving data.
22	23	VDD	<b>Positive Power Supply (Input).</b> Nominally 3.3 volts.
23	24	Sout	<b>Send PCM Signal Output (Output).</b> 128 kbit/s to 4096 kbit/s serial PCM output stream. Data may be in either companded or 2's complement linear PCM format. This is the Send Out signal after acoustic echo cancellation and non-linear processing. Data bits are clocked out following SSI, ST-BUS, or GCI timing requirements.
24	26	Rout	<b>Receive PCM Signal Output (Output).</b> 128 kbit/s to 4096 kbit/s serial PCM output stream. Data may be in either companded or 2's complement linear PCM format. This is the Receive out signal after line echo cancellation non-linear processing, AGC, and gain control. Data bits are clocked out following SSI, ST-BUS, or GCI timing requirements.
25	27	$\overline{\text{F0i}}$	<b>Frame Pulse (Input).</b> In ST-BUS (or GCI) operation, this is an active-low (or active-high) frame alignment pulse, respectively. SSI operation is enabled by connecting this pin to Vss.
26	29	BCLK/ $\overline{\text{C4i}}$	<b>Bit Clock/ST-BUS Clock (Input).</b> In SSI operation, BCLK pin is a 128 kHz to 4.096 MHz bit clock. This clock must be synchronous with ENA1, and ENA2 enable strobes. In ST-BUS or GCI operation, $\overline{\text{C4i}}$ pin must be connected to the 4.096 MHz ( $\overline{\text{C4}}$ ) system clock.

## Pin Description (continued)

QSOP Pin #	TQFP Pin #	Name	Description
27, 28	30,31	IC	<b>Internal Connection (Input).</b> Tie to Vss.
29	33	VSS2	<b>Digital Ground (Input):</b> Nominally 0 volts.
30	34	VDD2	<b>Positive Power Supply (Input):</b> Nominally 3.3 volts (tie together with VDD, pin 22).
31	35	VSS	<b>Digital Ground (Input):</b> Nominally 0 volts (tie together with VSS2, pin 29).
33	38	MCLK2	<b>Master Clock (Input):</b> Nominal 20 MHz master clock (tie together with MCLK, pin 8).
15,16,2 1,32	1, 4, 10, 12, 14, 15, 18, 20, 22, 25, 28, 32, 36, 37, 42, 44	NC	<b>No Connect (Output).</b> This pin should be left unconnected.
34, 35, 36	30,40,41	IC	<b>Internal Connection (Input).</b> Tie to Vss.

Notes: 1. All inputs have CMOS compatible, 5 V-tolerant logic levels.

2. All outputs have CMOS logic levels. Rout, Sout, and DATA1 are 5 V-tolerant when tristated (to withstand other 5 V drivers on a shared bus).

## Glossary

Double-Talk	Simultaneous signals present on Rin and Sin.
Near-end Single-Talk	Signals only present at Sin input.
Far-end Single-Talk	Signals only present at Rin input.
ADV NLP	Advanced Non-Linear-Processor
Howling	Oscillation caused by feedback from acoustic and line echo paths
Narrowband	Any mono or dual sinusoidal signals
NBSD	Narrow Band Signal Detector
Noise-Gating	Audible switching of background noise
Offset Nulling	Removal of DC component
Reverberation time	The time duration before an echo level decays to -60 dBm

## Changes Summary

The following table captures the changes from the July 2004 issue.

Page	Item	Change
3 and 4	Pin Description Table	Corrected TQFP pinout table. Pin names and descriptions for pins 16-35, 38-41 and 43 were incorrect.

## Functional Description

The MT93L16 device contains two echo cancellers, as well as the many control functions necessary to operate the echo cancellers. One canceller is for acoustic speaker to microphone echo, and one for line echo cancellation. The MT93L16 provides clear signal transmission in both audio path directions to ensure reliable voice communication, even with low level signals. The MT93L16 does not use variable attenuators during double-talk or single-talk periods of speech, as do many other acoustic echo cancellers for speaker-phones. Instead, the MT93L16 provides high performance full-duplex operation similar to network echo cancellers, so that users experience clear speech and un-interrupted background signals during the conversation. This prevents subjective sound quality problems associated with “noise gating” or “noise contrasting”.

The MT93L16 uses an advanced adaptive filter algorithm that is double-talk stable, which means that convergence takes place even while both parties are talking<sup>1</sup>. This algorithm allows continual tracking of changes in the echo path, regardless of double-talk, as long as a reference signal is available for the echo canceller.

The echo tail cancellation capability of the acoustic echo canceller has been sized appropriately (112 ms) to cancel echo in an average sized office with a reverberation time of less than 112 ms. The 16 ms line echo canceller is sufficient to ensure a high ERLE for most line circuits.

In addition to the echo cancellers, the following functions are supported:

- Control of adaptive filter convergence speed during periods of double-talk, far end single-talk, and near-end echo path changes.
- Control of Non-Linear Processor thresholds for suppression of residual non-linear echo.
- Howling detector to identify when instability is starting to occur, and to take action to prevent oscillation.
- Narrow-Band Detector for preventing adaptive filter divergence caused by narrow-band signals
- Offset Nulling filters for removal of DC components in PCM channels.
- Limiters that introduce controlled saturation levels.
- Serial controller interface compatible with Motorola, National and Intel microcontrollers.
- PCM encoder/decoder compatible with  $\mu$ /A-Law ITU-T G.711,  $\mu$ /A-Law Sign-Mag or linear 2's complement coding.
- Automatic gain control on the receive speaker path.

## Adaptation Speed Control

The adaptation speed of the acoustic echo canceller is designed to optimize the convergence speed versus divergence caused by interfering near-end signals. Adaptation speed algorithm takes into account many different factors such as relative double-talk condition, far end signal power, echo path change and noise levels to achieve fast convergence.

---

1. Patented.

**Advanced Non-Linear Processor (ADV-NLP)<sup>1</sup>**

After echo cancellation, there is likely to be residual echo which needs to be removed so that it will not be audible. The MT93L16 uses an NLP to remove low level residual echo signals which are not comprised of background noise. The operation of the NLP depends upon a dynamic activation threshold, as well as a double-talk detector which disables the NLP during double-talk periods.

The MT93L16 keeps the perceived noise level constant, without the need for any variable attenuators or gain switching that causes audible “noise gating”. The noise level is constant and identical to the original background noise even when the NLP is activated.

For each audio path, the NLP can be disabled by setting the NLP- bit to 1 in the LEC or AEC control registers.

**Narrow Band Signal Detector (NBSD)<sup>2</sup>**

Single or multi-frequency tones (e.g., DTMF, or signalling tones) present in the reference input of an echo canceller for a prolonged period of time may cause the adaptive filter to diverge. The Narrow Band Signal Detector (NBSD) is designed to prevent this divergence by detecting single or multi-tones of arbitrary frequency, phase, and amplitude. When narrow band signals are detected, the filter adaptation process is stopped but the echo canceller continues to cancel echo.

The NBSD can be disabled by setting the NB- bit to 1 in the MC control registers.

**Howling Detector (HWLD)<sup>3</sup>**

The Howling detector is part of an Anti-Howling control, designed to prevent oscillation as a result of positive feedback in the audio paths.

The HWLD can be disabled by setting the AH- bit to 1 in the (MC) control register.

**Offset Null Filter**

To ensure robust performance of the adaptive filters at all times, any DC offset that may be present on either the Rin signal or the Sin signal, is removed by highpass filters. These filters have a corner frequency placed at 40 Hz.

The offset null filters can be disabled by setting the HPF- bit to 1 in the LEC or AEC control registers.

**Limiters**

To prevent clipping in the echo paths, two limiters with variable thresholds are provided at the outputs.

The Rout limiter threshold is in Rout Limiter Register 1 and 2. The Sout limiter threshold is in Sout Limiter Register. Both output limiters are always enabled.

**User Gain**

The user gain function provides the ability for users to adjust the audio gain in the receive path (speaker path). This gain is adjustable from -24 dB to +21 dB in 3 dB steps. It is important to use ONLY this user gain function to adjust the speaker volume. The user gain function in the MT93L16 is optimally placed between the two echo cancellers such that no reconvergence is necessary after gain changes.

The gain can be accessed through Receive Gain Control Register.

---

1. Patented.  
2. Patented.  
3. Patented.

## AGC

The AGC function is provided to limit the volume in the speaker path. The gain of the speaker path is automatically reduced during the following conditions:

- When clipping of the receive signal occurs.
- When initial convergence of the acoustic echo canceller detects unusually large echo return.
- When howling is detected.

The AGC can be disabled by setting the AGC- bit to 1 in MC control register.

## Mute Function

A pcm mute function is provided for independent control of the Receive and Send audio paths. Setting the MUTE\_R or MUTE\_S bit in the MC register, causes quiet code to be transmitted on the Rout or Sout paths respectively.

Quiet code is defined according to the following table:

	LINEAR 16 bits 2's complement	SIGN/ MAGNITUDE μ-Law A-Law	CCITT (G.711)	
			μ-Law	A-Law
+Zero (quiet code)	0000h	80h	FFh	D5h

**Table 2 - Quiet PCM Code Assignment**

## Bypass Control

A PCM bypass function is provided to allow transparent transmission of pcm data through the MT93L16. When the bypass function is active, pcm data passes transparently from Rin to Rout and from Sin to Sout, with bit-wise integrity preserved.

When the Bypass function is selected, most internal functions are powered down to provide low power consumption.

The BYPASS control bit is located in the main control MC register.

## Adaptation Enable/Disable

Adaptation control bits are located in the AEC and LEC control registers. When the ADAPT- bit is set to 1, the adaptive filter is frozen at the current state. In this state, the device continues to cancel echo with the current echo model.

When the ADAPT- bit is set to 0, the adaptive filter is continually updated. This allows the echo canceller to adapt and track changes in the echo path. This is the normal operating state.

## MT93L16 Throughput Delay

In all modes, voice channels always have 2 frames of delay. In ST-BUS/GCI operation, the D and C channels have a delay of one frame.

## Power Down / Reset

Holding the  $\overline{\text{RESET}}$  pin at logic low will keep the MT93L16 device in a power-down state. In this state all internal clocks are halted, and the DATA1, Sout and Rout pins are tristated.

The user should hold the  $\overline{\text{RESET}}$  pin low for at least 200 msec following power-up. This will insure that the device powers up in a proper state. Following any return of  $\overline{\text{RESET}}$  to logic high, the user must wait for 8 complete 8 KHz frames prior to writing to the device registers. During this time, the initialization routines will execute and set the MT93L16 to default operation (program execution from ROM using default register values).

**PCM Data I/O**

The PCM data transfer for the MT93L16 is provided through two PCM ports. One port consists of Rin and Sout pins while the second port consists of Sin and Rout pins. The data are transferred through these ports according to either ST-BUS, GCI, or SSI conventions, and the device automatically detects the correct convention. The device determines the convention by monitoring the signal applied to the  $\overline{\text{F0i}}$  pin. When a valid ST-BUS (active low) frame pulse is applied to the  $\overline{\text{F0i}}$  pin, the MT93L16 will assume ST-BUS operation. When a valid GCI (active high) frame pulse is applied to the  $\overline{\text{F0i}}$  pin, the device will assume GCI operation. If  $\overline{\text{F0i}}$  is tied continuously to Vss, the device will assume SSI operation. Figures 11 to 13 show timing diagrams of these 3 PCM-interface operation conventions.

**ST-BUS and GCI Operation**

The ST-BUS PCM interface conforms to Zarlink's ST-BUS standard, with an active-low frame pulse. Input data is clocked in by the rising edge of the bit clock ( $\overline{\text{C4i}}$ ) three-quarters of the way into the bitcell, and output data bit boundaries (Rout, Sout) occur every second falling edge of the bit clock (see Figure 11.) The GCI PCM interface corresponds to the GCI standard commonly used in Europe, with an active-high frame pulse. Input data is clocked in by the falling edge of the bit clock ( $\overline{\text{C4i}}$ ) three-quarters of the way into the bitcell, and output data bit boundaries (Rout, Sout) occur every second rising edge of the bit clock (see Figure 12.)

Either of these interfaces (STBUS or GCI) can be used to transport 8 bit companded PCM data (using one timeslot) or 16 bit 2's complement linear PCM data (using two timeslots). The MD1/ENA1 pins select the timeslot on the Rin/Sout port while the MD2/ENA2 pin selects the timeslot on the Sin/Rout port, as in Table 3. Figures 3 to 6 illustrate the timeslot allocation for each of these four modes.

PORT1 Rin/Sout		ST-BUS/GCI Mode Selection	PORT2 Sin/Rout	
Enable Pins			Enable Pins	
MD1	ENA1		MD2	ENA2
0	0	Mode 1. 8 bit companded PCM I/O on timeslot 0	0	0
0	1	Mode 2. 8 bit companded PCM I/O on timeslot 2.	0	1
1	0	Mode 3. 8 bit companded PCM I/O on timeslot 2. Includes D & C channel bypass in timeslots 0 & 1.	1	0
1	1	Mode 4. 16 bit 2's complement linear PCM I/O on timeslots 0 & 1.	1	1

**Table 3 - ST-BUS & GCI Mode Select**

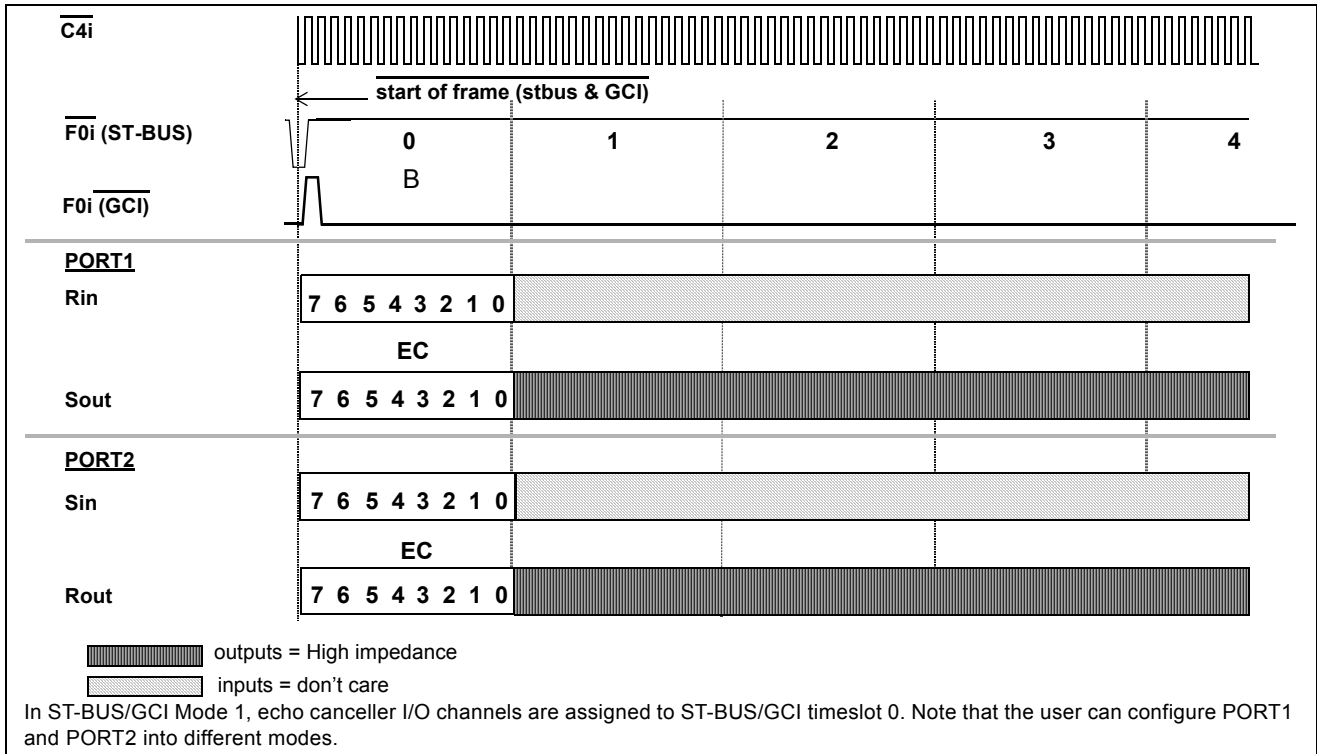

Figure 3 - ST-BUS and GCI 8-Bit Companded PCM I/O on Timeslot 0 (Mode 1)

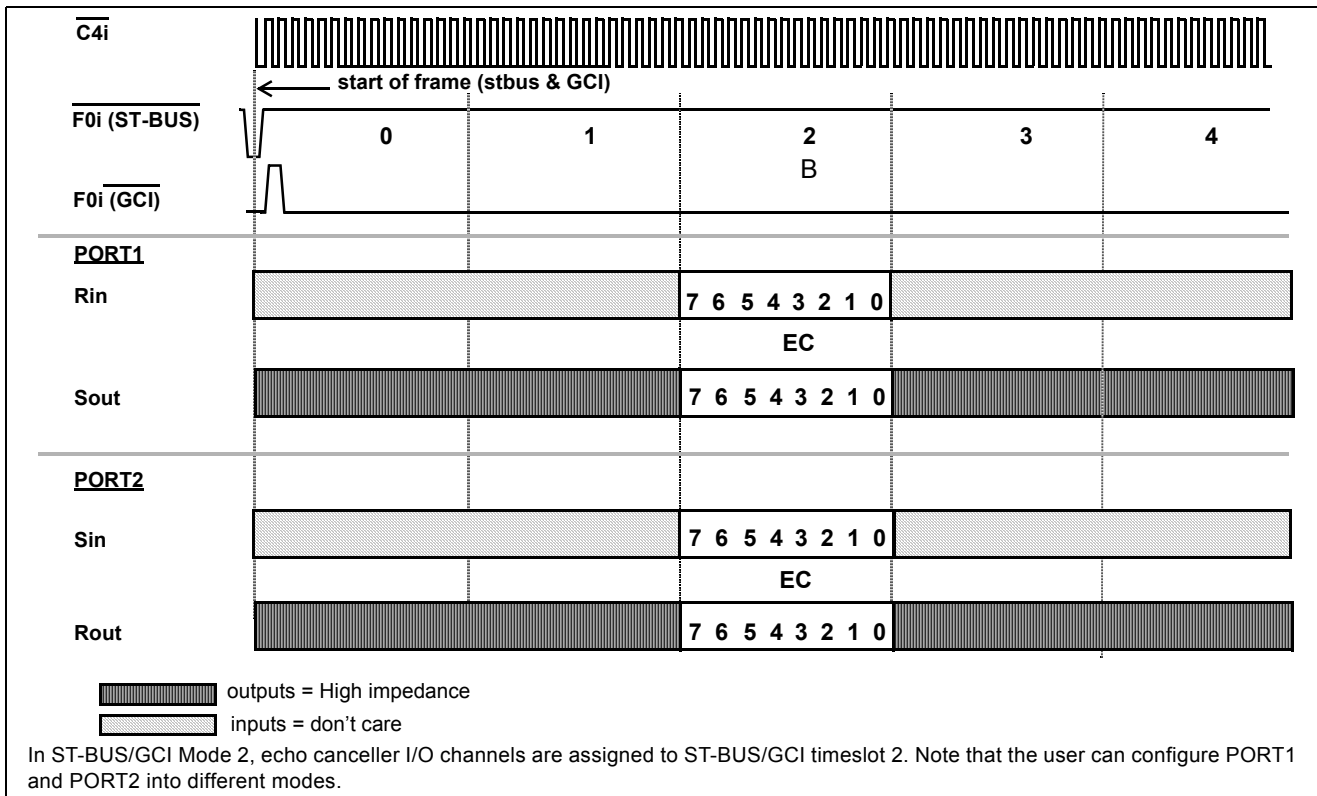

Figure 4 - ST-BUS and GCI 8-Bit Companded PCM I/O on Timeslot 2 (Mode 2)

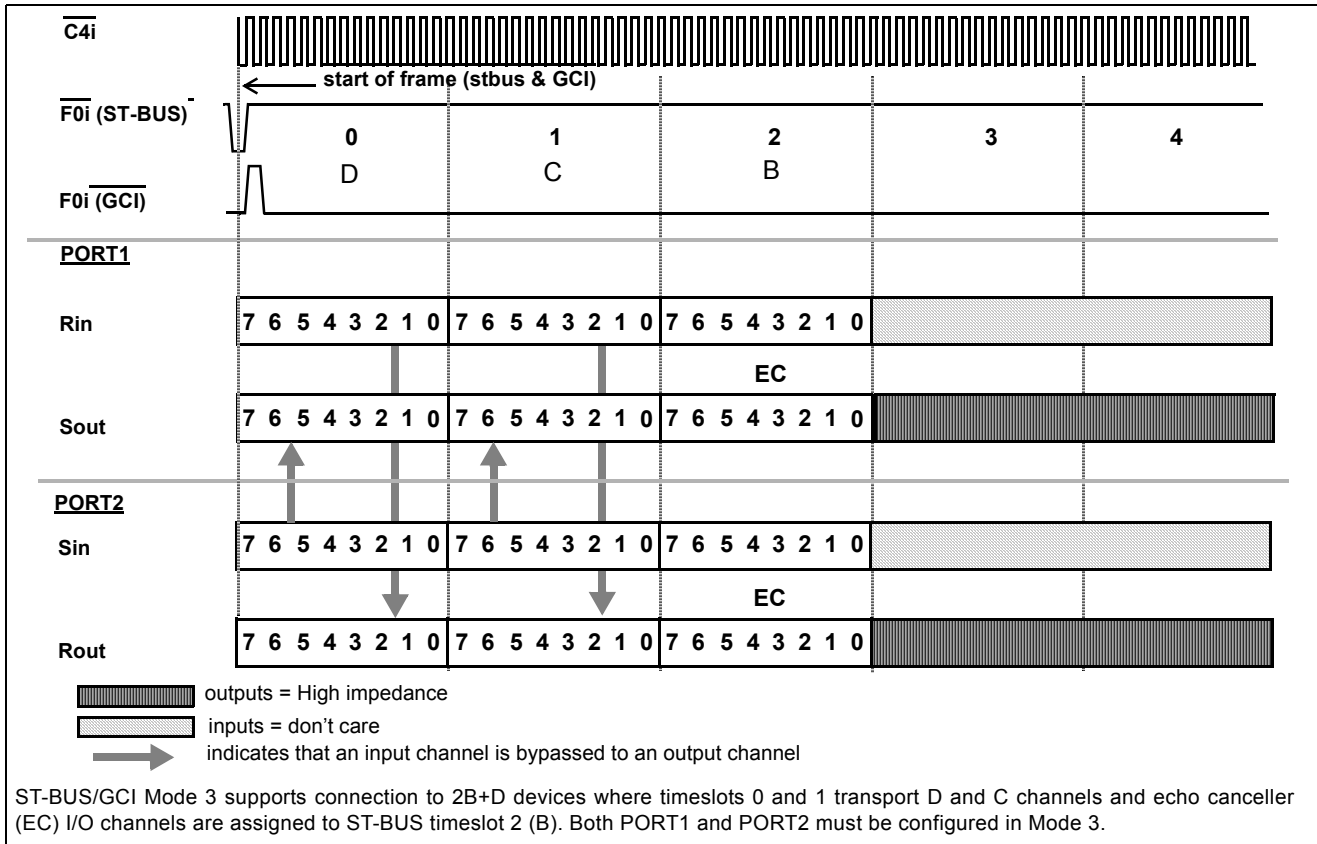

Figure 5 - ST-BUS and GCI 8-Bit Companded PCM I/O with D and C Channels (Mode 3)

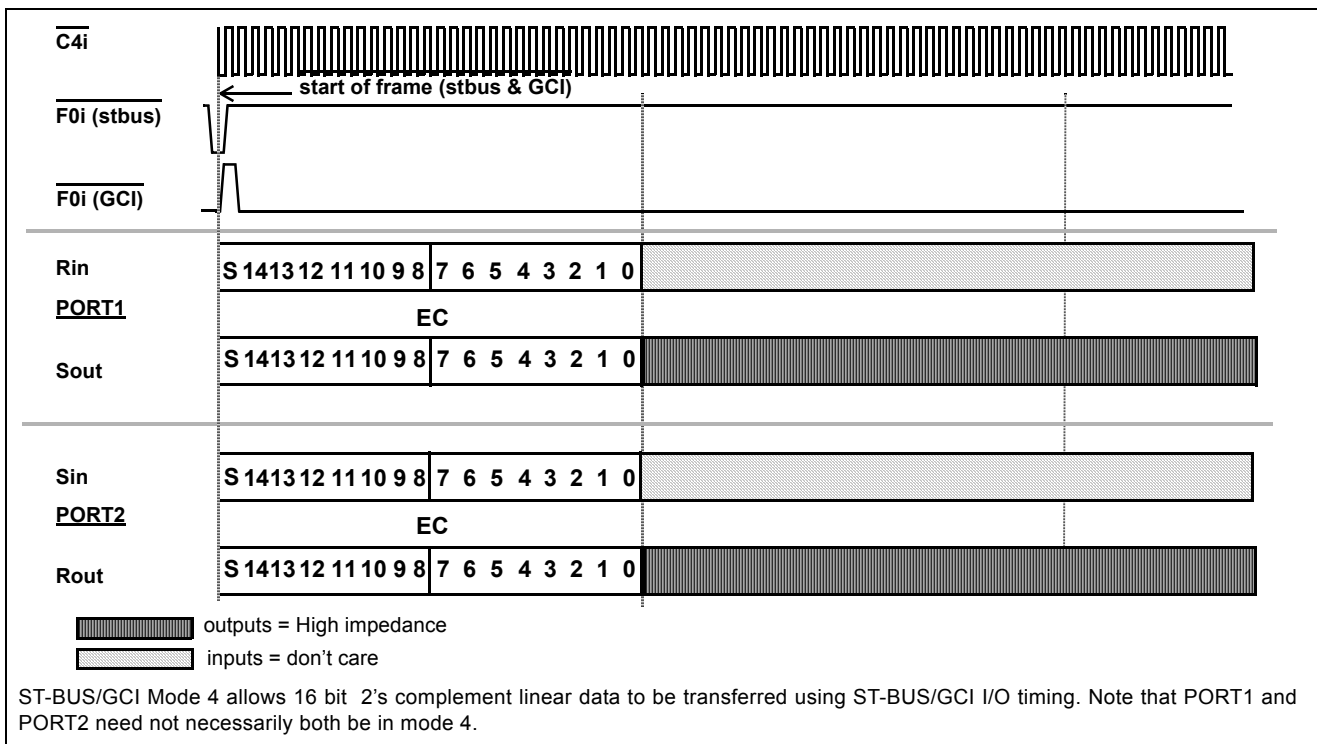

Figure 6 - ST-BUS and GCI 16-Bit 2's Complement Linear PCM I/O (Mode 4)

### SSI Operation

The SSI PCM interface consists of data input pins (Rin, Sin), data output pins (Sout, Rout), a variable rate bit clock (BCLK), and two enable pins (ENA1, ENA2) to provide strobes for data transfers. The active high enable may be either 8 or 16 BCLK cycles in duration. Automatic detection of the data type (8 bit companded or 16 bit 2's complement linear) is accomplished internally. The data type cannot change dynamically from one frame to the next.

In SSI operation, the frame boundary is determined by the rising edge of the ENA1 enable strobe (see Figure 7). The other enable strobe (ENA2) is used for parsing input/output data and it must pulse within 125 microseconds of the rising edge of ENA1.

In SSI operation, the enable strobes may be a mixed combination of 8 or 16 BCLK cycles allowing the flexibility to mix 2's complement linear data on one port (e.g., Rin/Sout) with companded data on the other port (e.g., Sin/Rout).

Enable Strobe Pin	Designated PCM I/O Port
ENA1	Line Side Echo Path (PORT 1)
ENA2	Acoustic Side Echo Path (PORT 2)

**Table 4 - SSI Enable Strobe Pins**

### PCM Law and Format Control (LAW, FORMAT)

The PCM companding/coding law used by the MT93L16 is controlled through the LAW and FORMAT pins. ITU-T G.711 companding curves for  $\mu$ -Law and A-Law are selected by the LAW pin. PCM coding ITU-T G.711 and Sign-Magnitude are selected by the FORMAT pin. See Table 5.

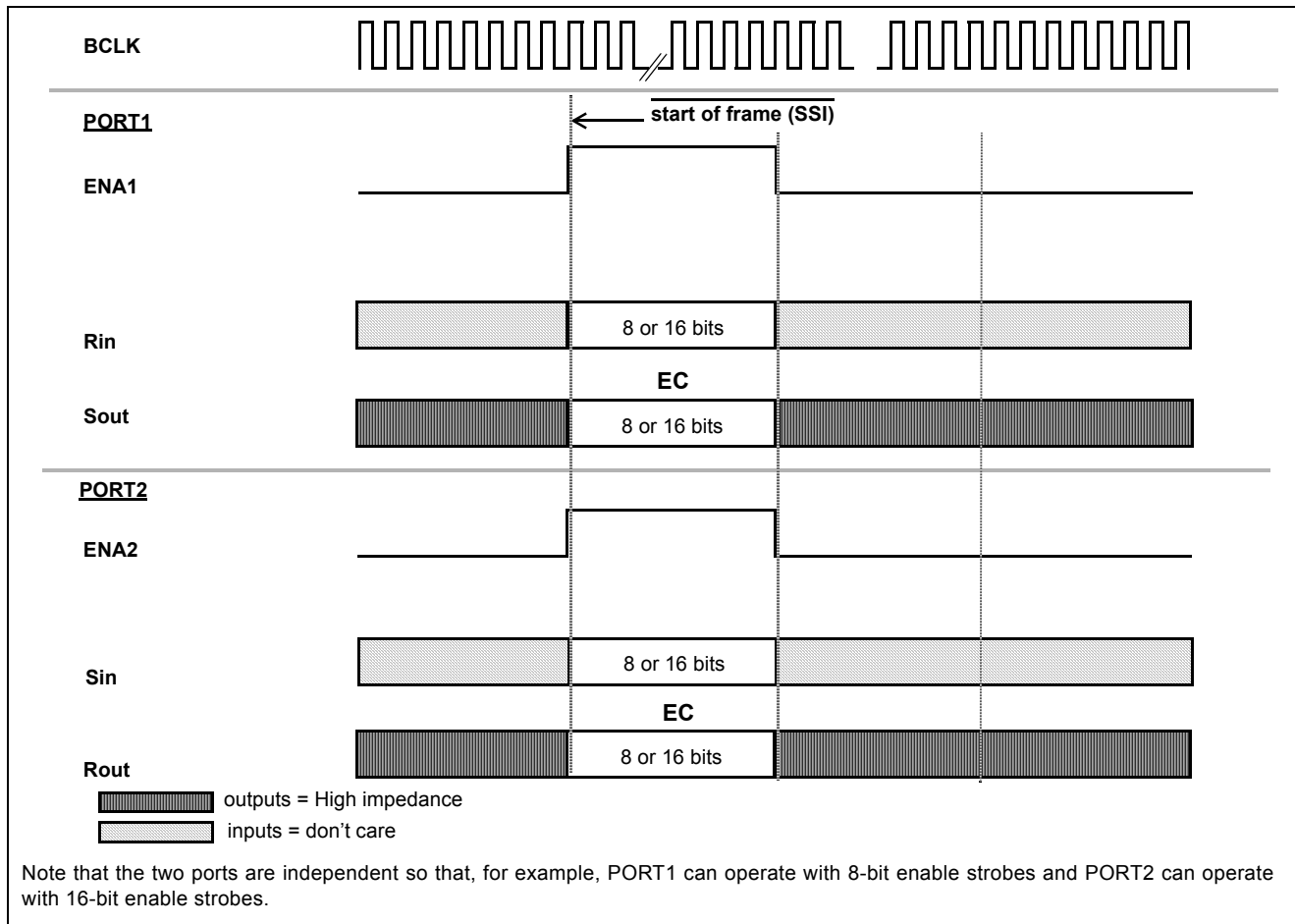

Figure 7 - SSI Operation

PCM Code	Sign-Magnitude FORMAT=0	ITU-T (G.711) FORMAT=1	
	$\mu$ /A-LAW LAW = 0 or 1	$\mu$ -LAW LAW = 0	A-LAW LAW = 1
+ Full Scale	1111 1111	1000 0000	1010 1010
+ Zero	1000 0000	1111 1111	1101 0101
- Zero	0000 0000	0111 1111	0101 0101
- Full Scale	0111 1111	0000 0000	0010 1010

Table 5 - Companded PCM

## Linear PCM

The 16-bit 2's complement PCM linear coding permits a dynamic range beyond that which is specified in ITU-T G.711 for companded PCM. The echo-cancellation algorithm will accept 16 bits 2's complement linear code which gives a maximum signal level of +15 dBm0.

## Bit Clock (BCLK/ $\overline{C4i}$ )

The BCLK/ $\overline{C4i}$  pin is used to clock the PCM data for GCI and ST-BUS ( $\overline{C4i}$ ) interfaces, as well as for the SSI (BCLK) interface.

In SSI operation, the bit rate is determined by the BCLK frequency. This input must contain either eight or sixteen clock cycles within the valid enable strobe window. BCLK may be any rate between 128 KHz to 4.096 MHz and can be discontinuous outside of the enable strobe windows defined by ENA1, ENA2 pins. Incoming PCM data (Rin, Sin) are sampled on the falling edge of BCLK while outgoing PCM data (Sout, Rout) are clocked out on the rising edge of BCLK. See Figure 13.

In ST-BUS and GCI operation, connect the system  $\overline{C4}$  (4.096 MHz) clock to the  $\overline{C4i}$  pin.

## Master Clock (MCLK)

A nominal 20 MHz, continuously-running master clock (MCLK) is required. MCLK may be asynchronous with the 8 KHz frame.

## Microport

The serial microport provides access to all MT93L16 internal read and write registers, plus write-only access to the bootloadable program RAM (see next section for bootload description.) This microport is compatible with Intel MCS-51 (mode 0), Motorola SPI (CPOL=0, CPHA=0), and National Semiconductor Microwire specifications. The microport consists of a transmit/receive data pin (DATA1), a receive data pin (DATA2), a chip select pin ( $\overline{CS}$ ) and a synchronous data clock pin (SCLK).

The MT93L16 automatically adjusts its internal timing and pin configuration to conform to Intel or Motorola/National requirements. The microport dynamically senses the state of the SCLK pin each time  $\overline{CS}$  pin becomes active (i.e. high to low transition). If SCLK pin is high during  $\overline{CS}$  activation, then Intel mode 0 timing is assumed. In this case DATA1 pin is defined as a bi-directional (transmit/receive) serial port and DATA2 is internally disconnected. If SCLK is low during  $\overline{CS}$  activation, then Motorola/National timing is assumed and DATA1 is defined as the data transmit pin while DATA2 becomes the data receive pin. The MT93L16 supports Motorola half-duplex processor mode (CPOL=0 and CPHA=0). This means that during a write to the MT93L16, by the Motorola processor, output data from the DATA1 pin must be ignored. This also means that input data on the DATA2 pin is ignored by the MT93L16 during a valid read by the Motorola processor.

All data transfers through the microport are two bytes long. This requires the transmission of a Command/Address byte followed by the data byte to be written to or read from the addressed register.  $\overline{CS}$  must remain low for the duration of this two-byte transfer. As shown in Figures 8 and 9, the falling edge of  $\overline{CS}$  indicates to the MT93L16 that a microport transfer is about to begin. The first 8 clock cycles of SCLK after the falling edge of  $\overline{CS}$  are always used to receive the Command/Address byte from the microcontroller. The Command/Address byte contains information detailing whether the second byte transfer will be a read or a write operation and at what address. The next 8 clock cycles are used to transfer the data byte between the MT93L16 and the microcontroller. At the end of the two-byte transfer,  $\overline{CS}$  is brought high again to terminate the session. The rising edge of  $\overline{CS}$  will tri-state the DATA1 pin. The DATA1 pin will remain tri-stated as long as  $\overline{CS}$  is high.

Intel processors utilize Least Significant Bit (LSB) first transmission while Motorola/National processors use Most Significant Bit (MSB) first transmission. The MT93L16 microport automatically accommodates these two schemes for normal data bytes. However, to ensure timely decoding of the R/W and address information, the Command/Address byte is defined differently for Intel and Motorola/National operations. Refer to the relative timing

diagrams of Figure 8 and Figure 9. Receive data bits are sampled on the rising edge of SCLK while transmit data is clocked out on the falling edge of SCLK. Detailed microport timing is shown in Figure 14 and Figure 15.

### Bootload Process and Execution from RAM

A bootloadable program RAM (BRAM) is available on the MT93L16 to support factory-issued software upgrades to the built-in algorithm. To make use of this bootload feature, users must include 4096 X 8 bits of memory in their microcontroller system (i.e., external to the MT93L16), from which the MT93L16 can be bootloaded. Registers and program data are loaded into the MT93L16 in the same fashion via the serial microport. Both employ the same command / address / data byte specification described in the previous section on serial microport. Either intel or motorola mode may be transparently used for bootloading. There are also two registers relevant to bootloading (BRC=control and SIG=signature, see Register Summary). The effect of these register values on device operation is summarized in Table 6.

FUNCTIONAL DESCRIPTION FOR USING THE BOOTABLE RAM			
<b>BOOTLOAD MODE - Microport Access is to bootload RAM (BRAM)</b>			
BRC Register Bits $C_3C_2C_1C_0$ <b>X 1 0 0</b>	R/W	Address	Data
	W	3fh (= 1 1 1 1 1 1 b)	Writes "data" to BRC reg. - Bootload frozen; BRAM contents are NOT affected.
	W	other than 3fh	Writes "data" to next byte in BRAM (bootloading.)
	R	1 x x x x b	Reads back "data" = BRC reg value. - Bootload frozen; BRAM contents are NOT affected.
	R	0 x x x x b	Reads back "data" = SIG reg value. - Bootload frozen; BRAM contents are NOT affected.
<b>NON-BOOTLOAD MODE - Microport Access is to device registers (DREGs)</b>			
BRC Register Bits $C_3C_2C_1C_0$ <b>X 0 0 0</b>	R/W	Address	Data
	W	any (= $a_5 a_4 a_3 a_2 a_1 a_0 b$ )	Writes "data" to corresponding DREG.
	R	any (= $a_5 a_4 a_3 a_2 a_1 a_0 b$ )	Reads back "data" = corresponding DREG value.
<b>PROGRAM EXECUTION MODES</b>			
$C_3C_2C_1C_0$ <b>0 0 0 0</b>	Execute program in ROM, bootload mode disabled. - BRAM address counter reset to initial (ready) state. - SIG reg reseeded to initial (ready) state		
$C_3C_2C_1C_0$ <b>0 1 0 0</b>	Execute program in ROM, while bootloading the RAM. - BRAM address counter increments on microport writes (except to 3fh) - SIG reg recalculates signature on microport writes (except to 3fh)		
$C_3C_2C_1C_0$ <b>1 0 0 0</b>	Execute program in RAM, bootload mode disabled. - BRAM address counter reset to initial (ready) state. - SIG reg reseeded to initial (ready) state		
$C_3C_2C_1C_0$ <b>1 1 0 0</b>	- NOT RECOMMENDED - (Execute program in RAM, while bootloading the RAM)		

**Table 6 - Bootload RAM Control (BRC) Register States**

Note: bits  $C_1 C_0$  are reserved, and must be set to zero.

Bootload mode is entered and exited by writing to the bootload bit in the Bootload RAM Control (BRC) register at address 3fh (see Register Summary). During bootload mode, any serial microport "write" (R/W command bit =0) to an address other than that of the BRC register will contribute to filling the program BRAM. Call these transactions "BRAM-fill" writes. Although a command/address byte must still precede each data byte (as described for the serial microport), the values of the address fields for these "BRAM-fill" writes are ignored (except for the value 3fh, which designates the BRC register.) Instead, addresses are internally generated by the MT93L16 for each "BRAM-fill" write. Address generation for "BRAM-fill" writes resumes where it left off following any read transaction while bootload mode is enabled. The first 4096 such "BRAM-fill" writes while bootload is enabled will load the memory, but further ones after that are ignored. Following the write of the first 4096 bytes, the program BRAM will be filled. Before bootload *mode is disabled*, it is recommended that users then read back the value from the signature register (SIG) and compare it to the one supplied by the factory along with the code. Equality verifies that the correct data has been loaded. The signature calculation uses an 8-bit MISR which only incorporates input from "BRAM-fill" writes. Resetting the bootload bit (**C<sub>2</sub>**) in the BRC register to 0 (see Register Summary) exits bootload mode, resetting the signature (SIG) register and internal address generator for the next bootload. A hardware reset ( $\overline{\text{RESET}}=0$ ) similarly returns the MT93L16 to the ready state for the start of a bootload.

Once the program has been loaded, to begin execution from RAM, bootload mode must be disabled (BOOT bit, **C<sub>2</sub>**=0) and execution from RAM enabled (RAM\_ROMb bit, **C<sub>3</sub>**=1) by setting the appropriate bits in the BRC register. During the bootload process, however, ROM program execution (RAM\_ROMb bit, **C<sub>3</sub>**=0) should be selected. See Table 6 for the effect of the BRC register settings on Microport accesses and on program execution.

Following program loading and enabling of execution from RAM, it is recommended that users set the software reset bit in the Main Control (MC) register, to ensure that the device updates the default register values to those of the new program in RAM. Note: it is important to use a software reset rather than a hardware ( $\overline{\text{RESET}}=0$ ) reset, as the latter will return the device to its default settings (which includes execution from program ROM instead of RAM.)

To verify which code revision is currently running, users can access the Firmware Revision Code (FRC) register (see Register Summary). This register reflects the identity code (revision number) of the last program to run register initialization (which follows a software or hardware reset.)

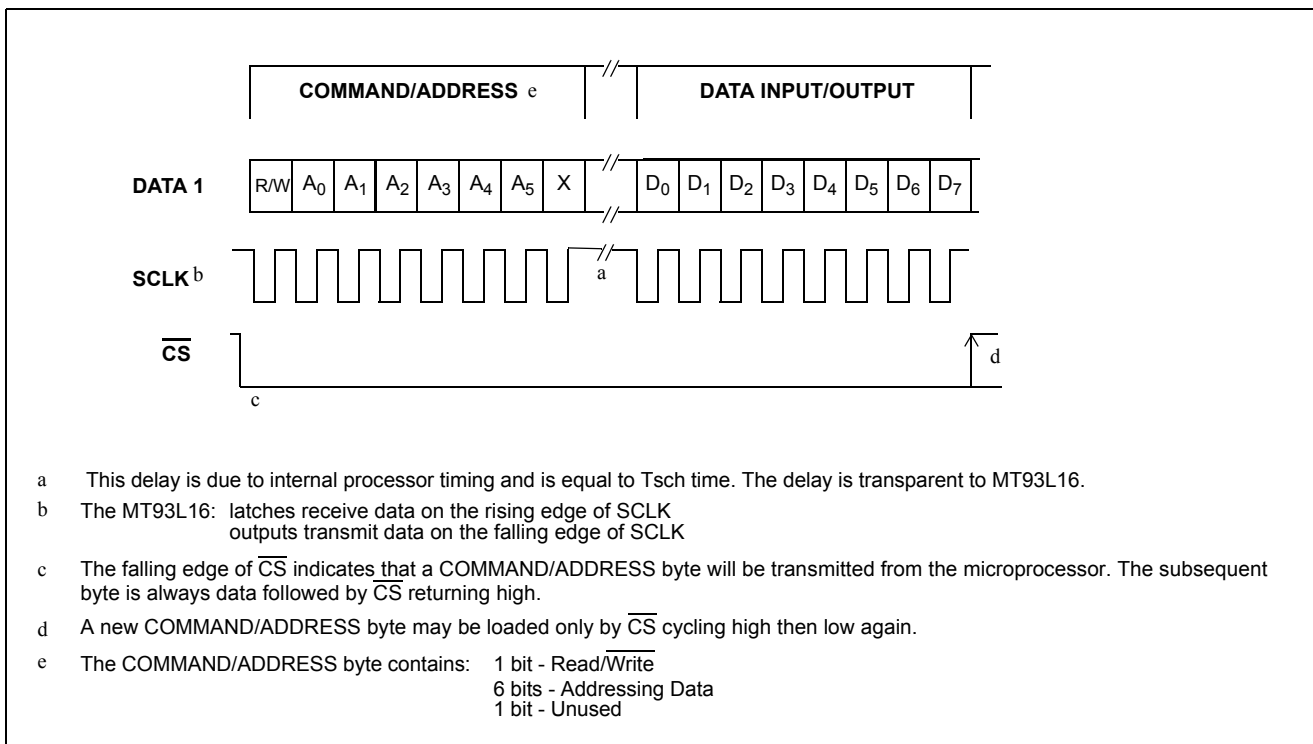
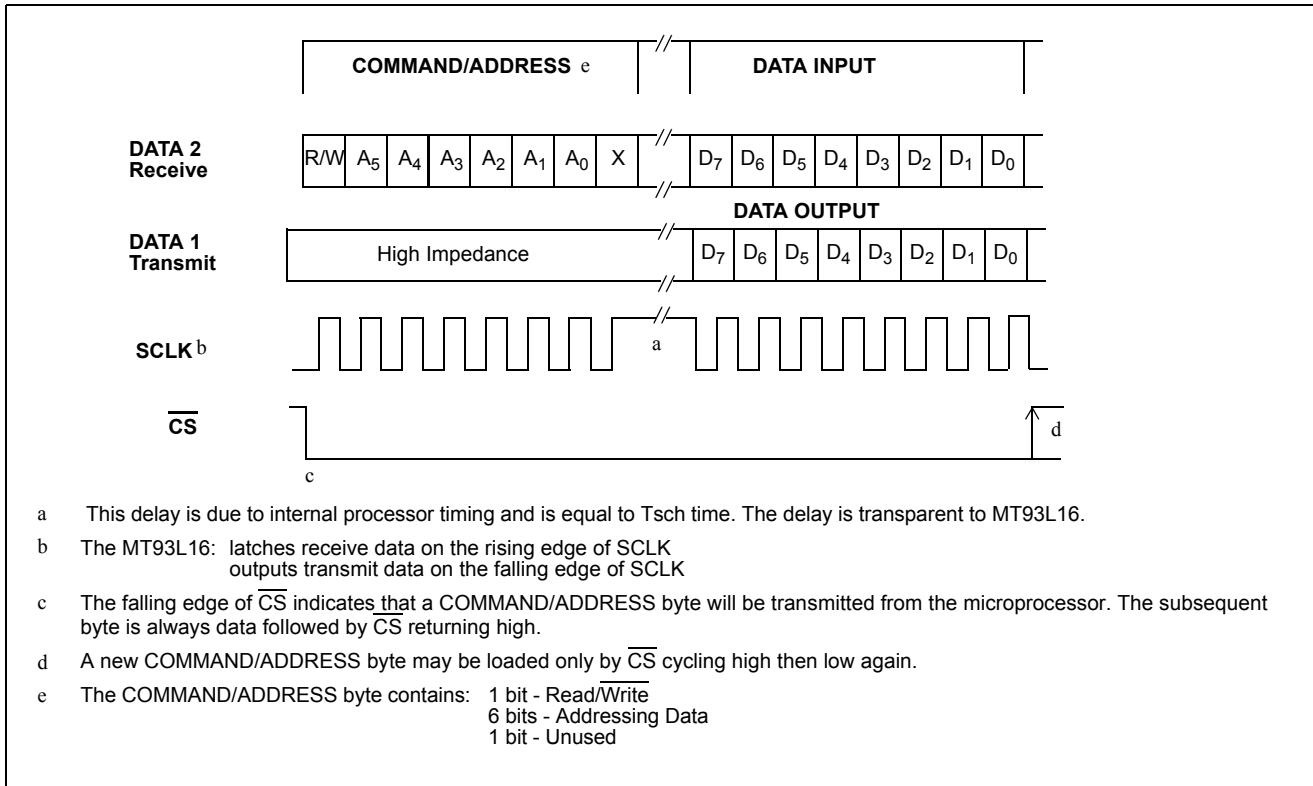

Figure 8 - Serial Microport Timing for Intel Mode 0



**Figure 9 - Serial Microport Timing for Motorola Mode 00 or National Microwire**

**Absolute Maximum Ratings\***

	Parameter	Symbol	Min.	Max.	Units
1	Supply Voltage	$V_{DD}-V_{SS}$	-0.5	5.0	V
2	Input Voltage	$V_i$	$V_{SS}-0.3$	5.5	V
3	Output Voltage Swing	$V_o$	$V_{SS}-0.3$	5.5	V
4	Continuous Current on any digital pin	$I_{i/o}$		$\pm 20$	mA
5	Storage Temperature	$T_{ST}$	-65	150	°C
6	Package Power Dissipation	$P_D$		90 (typ)	mW

\* Exceeding these values may cause permanent damage. Functional operation under these conditions is not implied.

**Recommended Operating Conditions** - Voltages are with respect to ground ( $V_{SS}$ ) unless otherwise stated

	Characteristics	Sym.	Min.	Typ.	Max.	Units	Test Conditions
1	Supply Voltage	$V_{DD}$	2.7	3.3	3.6	V	
2	Input High Voltage		1.4		$V_{DD}$	V	
3	Input Low Voltage		$V_{SS}$		0.4	V	
4	Operating Temperature	$T_A$	-40		+85	°C	

**Echo Return Limits**

	Characteristics	Min.	Typ.	Max.	Units	Test Conditions
1	Acoustic Echo Return			0	dB	Measured from Rout -> Sin
2	Line Echo Return			0	dB	Measured from Sout -> Rin

**DC Electrical Characteristics\*** - Voltages are with respect to ground ( $V_{SS}$ ) unless otherwise stated.

	Characteristics	Sym.	Min.	Typ <sup>‡</sup>	Max.	Units	Conditions/Notes
1	Standby Supply Current:	$I_{CC}$		3	70	$\mu A$	$\overline{RESET} = 0$
	Operating Supply Current:	$I_{DD}$		20		mA	$\overline{RESET} = 1$ , clocks active
2	Input HIGH voltage	$V_{IH}$	$0.7V_{DD}$			V	
3	Input LOW voltage	$V_{IL}$			$0.3V_{DD}$	V	
4	Input leakage current	$I_{IH}/I_{IL}$		0.1	10	$\mu A$	$V_{IN}=V_{SS}$ to $V_{DD}$
5	High level output voltage	$V_{OH}$	$0.8V_{DD}$			V	$I_{OH}=2.5$ mA
6	Low level output voltage	$V_{OL}$			$0.4V_{DD}$	V	$I_{OL}=5.0$ mA
7	High impedance leakage	$I_{OZ}$		1	10	$\mu A$	$V_{IN}=V_{SS}$ to $V_{DD}$
8	Output capacitance	$C_o$		10		pF	
9	Input capacitance	$C_i$		8		pF	

<sup>‡</sup> Typical figures are at 25°C and are for design aid only; not guaranteed and not subject to production testing.

\*DC Electrical Characteristics are over recommended temperature and supply voltage.

**AC Electrical Characteristics<sup>†</sup> - Serial Data Interfaces** - Voltages are with respect to ground ( $V_{SS}$ ) unless otherwise stated

	Characteristics	Sym.	Min.	Typ.	Max.	Units	Test Notes
1	MCLK Frequency	$f_{CLK}$	19.15		20.5	MHz	
2	BCLK/ $\overline{C4i}$ Clock High	$t_{BCH}$ , $t_{C4H}$	90			ns	
3	BCLK/ $\overline{C4i}$ Clock Low	$t_{BLL}$ , $t_{C4L}$	90			ns	
4	BCLK/ $\overline{C4i}$ Period	$t_{BCP}$	240		7900	ns	
5	SSI Enable Strobe to Data Delay (first bit)	$t_{SD}$	80			ns	$C_L=150$ pF
6	SSI Data Output Delay (excluding first bit)	$t_{DD}$	80			ns	$C_L=150$ pF
7	SSI Output Active to High Impedance	$t_{AHZ}$	80			ns	$C_L=150$ pF
8	SSI Enable Strobe Signal Setup	$t_{SSS}$	10		$t_{BCP}$ -15	ns	
9	SSI Enable Strobe Signal Hold	$t_{SSH}$	15		$t_{BCP}$ -10	ns	
10	SSI Data Input Setup	$t_{DIS}$	10			ns	
11	SSI Data Input Hold	$t_{DIH}$	15			ns	
12	ST-BUS/GCI $\overline{F0i}$ Setup	$t_{F0iS}$	20		150	ns	
13	ST-BUS/GCI $\overline{F0i}$ Hold	$t_{F0iH}$	20		150	ns	
14	ST-BUS/GCI Data Output delay	$t_{DSD}$	80			ns	$C_L=150$ pF
15	ST-BUS/GCI Output Active to High Impedance	$t_{ASHZ}$	80			ns	$C_L=150$ pF
16	ST-BUS/GCI Data Input Hold time	$t_{DSH}$	20			ns	
17	ST-BUS/GCI Data Input Setup time	$t_{DSS}$	20			ns	

<sup>†</sup> Timing is over recommended temperature and power supply voltages.

**AC Electrical Characteristics<sup>†</sup> - Microport Timing**

	Characteristics	Sym.	Min.	Typ.	Max.	Units	Test Notes
1	Input Data Setup	$t_{IDS}$	30			ns	
2	Input Data Hold	$t_{IDH}$	30			ns	
3	Output Data Delay	$t_{ODD}$	100			ns	$C_L=150$ pF
4	Serial Clock Period	$t_{SCP}$	500			ns	
5	SCLK Pulse Width High	$t_{SCH}$	250			ns	
6	SCLK Pulse Width Low	$t_{SCL}$	250			ns	
7	$\overline{CS}$ Setup-Intel	$t_{CSSI}$	200			ns	
8	$\overline{CS}$ Setup-Motorola	$t_{CSSM}$	100			ns	
9	$\overline{CS}$ Hold	$t_{CSH}$	100			ns	
10	$\overline{CS}$ to Output High Impedance	$t_{OHZ}$	100			ns	$C_L=150$ pF

<sup>†</sup> Timing is over recommended temperature range and recommended power supply voltages.

Characteristic	Symbol	CMOS Level	Units
CMOS reference level	$V_{CT}$	$0.5 \cdot V_{DD}$	V
Input HIGH level	$V_H$	$0.9 \cdot V_{DD}$	V
Input LOW level	$V_L$	$0.1 \cdot V_{DD}$	V
Rise/Fall HIGH measurement point	$V_{HM}$	$0.7 \cdot V_{DD}$	V
Rise/Fall LOW measurement point	$V_{LM}$	$0.3 \cdot V_{DD}$	V

**Table 7 - Reference Level Definition for Timing Measurements**

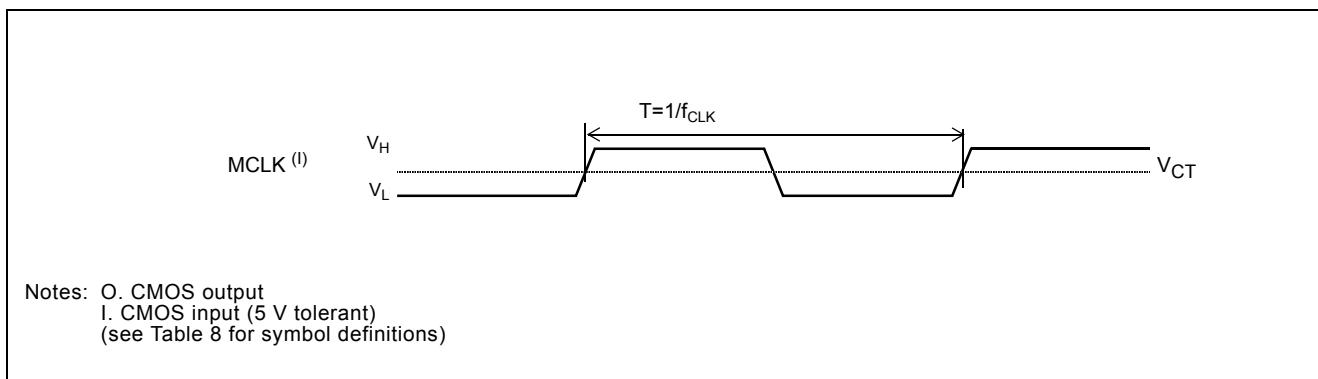

**Figure 10 - Master Clock - MCLK**

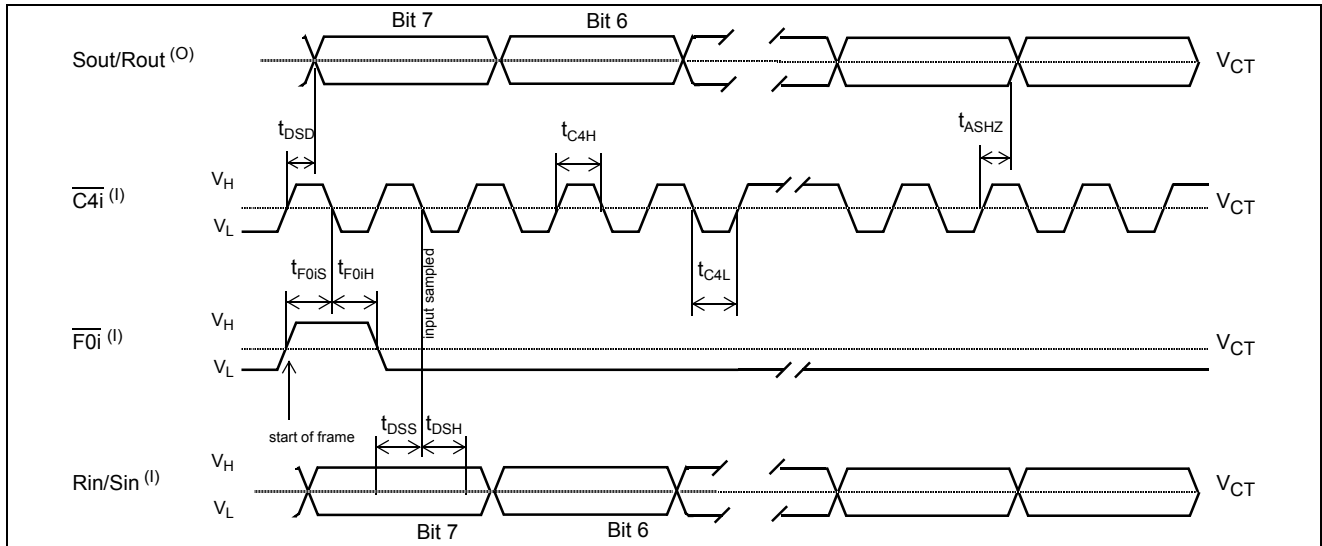

Figure 11 - GCI Data Port Timing

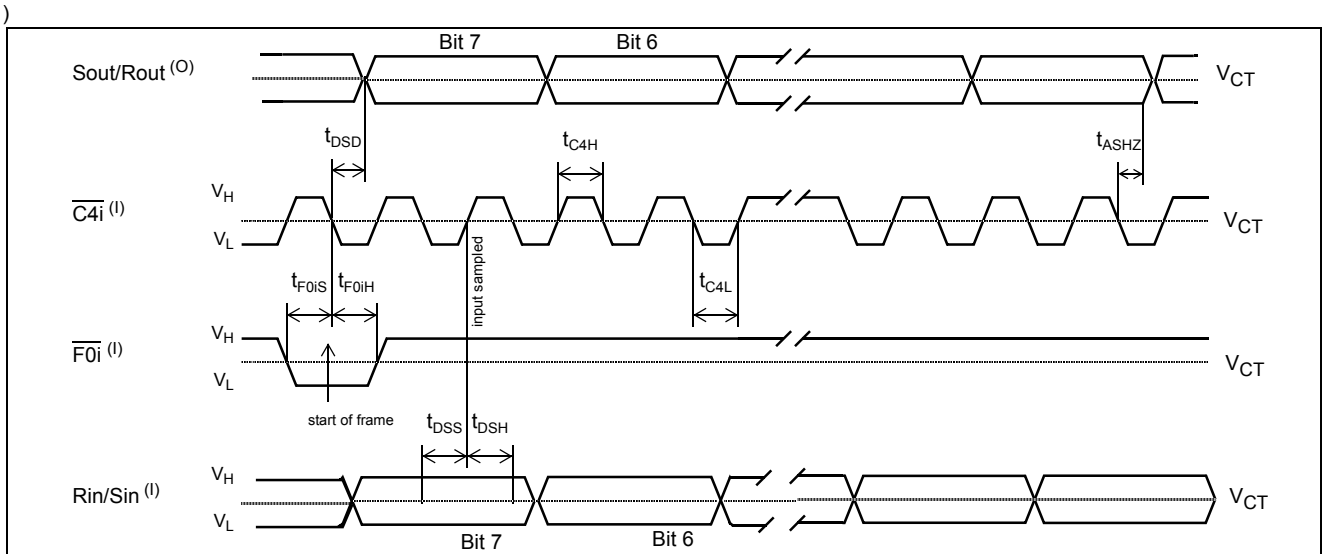

Figure 12 - ST-BUS Data Port Timing

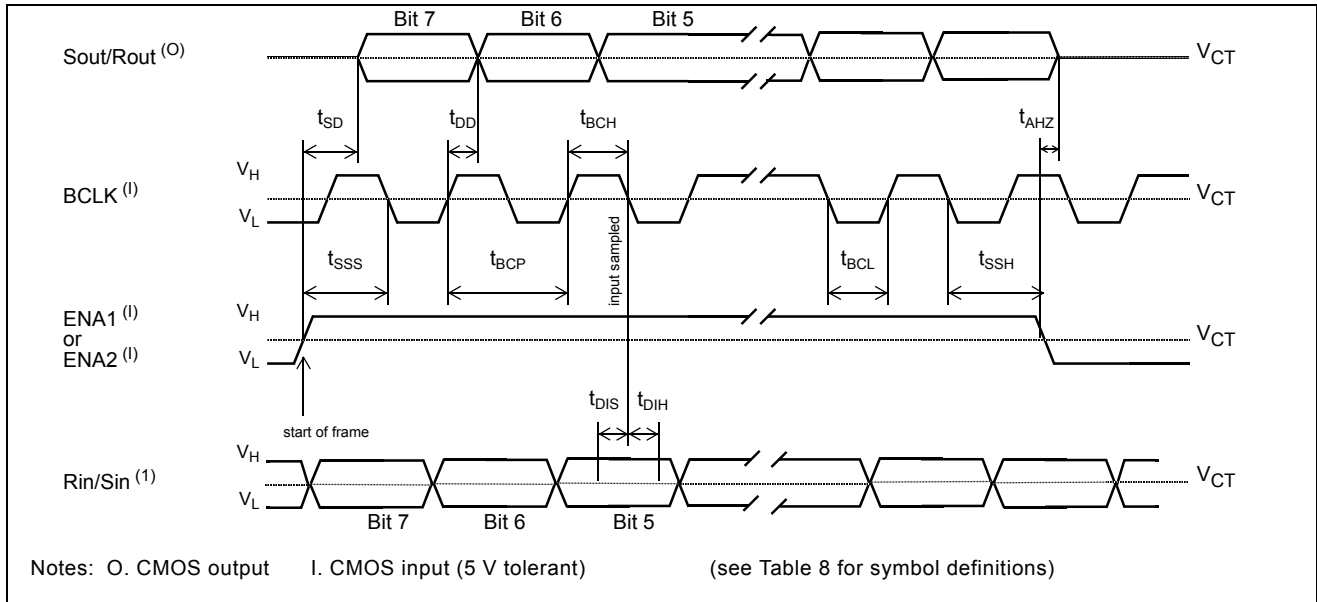

Figure 13 - SI Data Port Timing

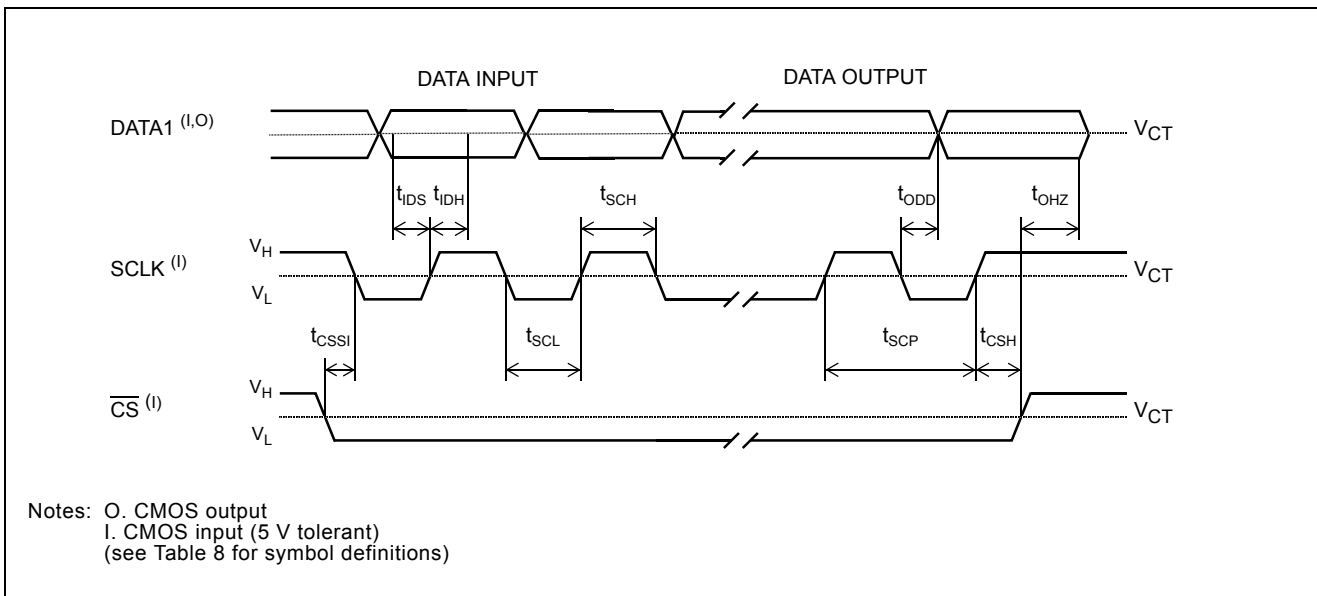

Figure 14 - INTEL Serial Microport Timing

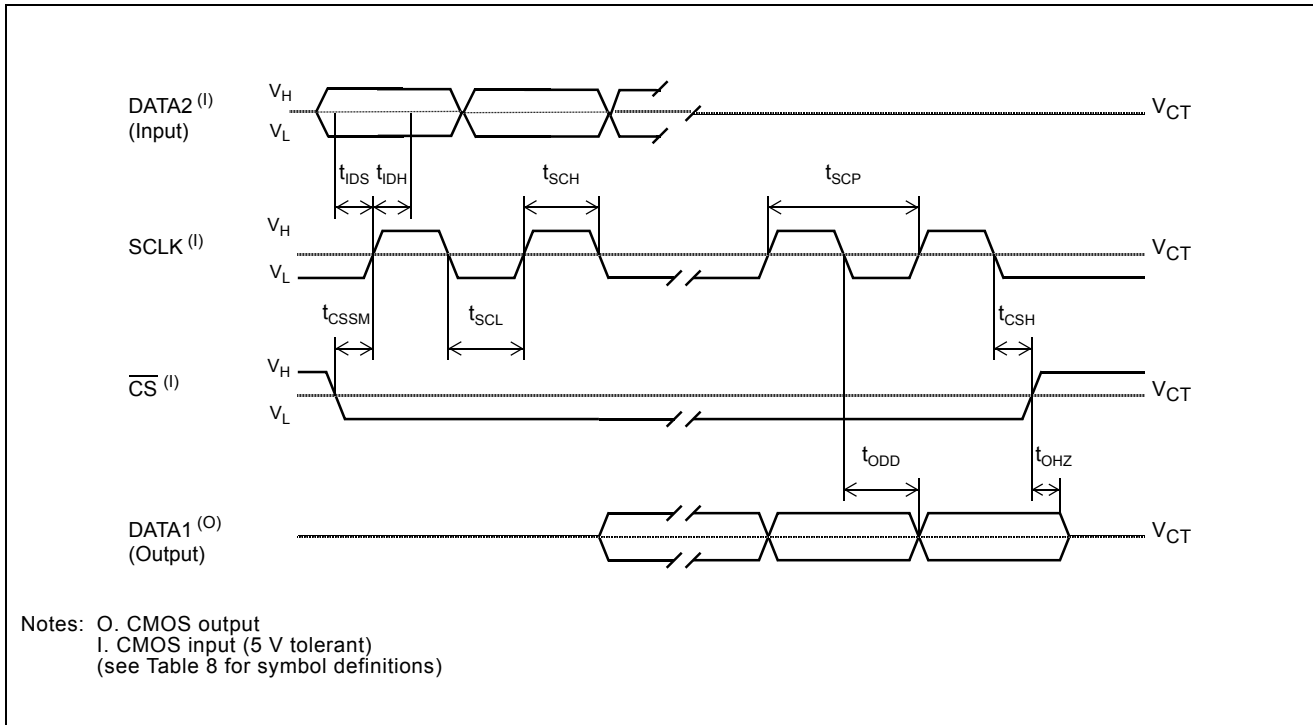

Figure 15 - Motorola Serial Microport Timing

## Register Summary

Address: 00h R/W	Main Control Register (MC)																	
Power Up Reset 00h	MSB	7	LIMIT	6	MUTE_R	5	MUTE_S	4	BYPASS	3	NB-	2	AGC-	1	AH-	0	RESET	LSB
<b>RESET</b>	When high, the power initialization routine is executed presetting all registers to default values. This bit automatically clears itself to '0' when reset is complete.																	
<b>AH-</b>	When high, the Howling detector is disabled and when low the Howling detector is enabled.																	
<b>AGC-</b>	When high, AGC is disabled and when low AGC is enabled.																	
<b>NB-</b>	When high, Narrowband signal detectors in Rin and Sin paths are disabled and when low the signal detectors are enabled																	
<b>BYPASS</b>	When high, the Send and Receive paths are transparently by-passed from input to output and when low the Send and Receive paths are not bypassed																	
<b>MUTE_S</b>	When high, the Sin path is muted to quite code (after the NLP) and when low the Sin path is not muted																	
<b>MUTE_R</b>	When high, the Rin path is muted to quite code (after the NLP) and when low the Rin path is not muted																	
<b>LIMIT</b>	When high, the 2-bit shift mode is enabled in conjunction with bit 7 of LEC register and when low 2-bit shift mode is disabled																	

Address: 21h R/W	Acoustic Echo Canceller Control Register (AEC)																	
Power Up Reset 00h	MSB	7	P-	6	ASC-	5	NLP-	4	INJ-	3	HPF-	2	HCLR	1	ADAPT-	0	ECBY	LSB
<b>ECBY</b>	When high, the Echo estimate from the filter is not subtracted from the input (Sin), when low the estimate is subtracted																	
<b>ADAPT-</b>	When high, the Echo canceller adaptation is disabled and when low the adaptation is enabled																	
<b>HCLR</b>	When high, Adaptive filter coefficients are cleared and when low the filter coefficients are not cleared																	
<b>HPF-</b>	When high, Offset nulling filter is bypassed in the Sin/Sout path and when low the Offset nulling filter in not bypassed																	
<b>INJ-</b>	When high, the Noise filtering process is disabled in the NLP and when low the Noise filtering process is enabled																	
<b>NLP-</b>	When high, the Non Linear Processor is disabled in the Sin/Sout path and when low the NLP is enabled																	
<b>ASC-</b>	When high, the Internal Adaptation speed control is disabled and when low the Adaptation speed is enabled																	
<b>P-</b>	When high, the Exponential weighting function for the adaptive filter is disabled and when low the weighting function is enabled																	

Address: 01h R/W	Line Echo Canceller Control Register (LEC)																	
Power Up Reset 00h	MSB	7	SHFT	6	ASC-	5	NLP-	4	INJ-	3	HPF-	2	HCLR	1	ADAPT-	0	ECBY	LSB
<b>ECBY</b>	When high, the Echo estimate from the filter is not subtracted from the input (Rin), when low the estimate is subtracted																	
<b>ADAPT-</b>	When high, the Echo canceller adaptation is disabled and when low the adaptation is enabled																	
<b>HCLR</b>	When high, Adaptive filter coefficients are cleared and when low the filter coefficients are not cleared																	
<b>HPF-</b>	When high, Offset nulling filter is bypassed in the Rin/Rout path and when low the Offset nulling filter in not bypassed																	
<b>INJ-</b>	When high, the Noise filtering process is disabled in the NLP and when low the Noise filtering process is enabled																	
<b>NLP-</b>	When high, the Non Linear Processor is disabled in the Rin/Rout path and when low the NLP is enabled																	
<b>ASC-</b>	When high, the Internal Adaptation speed control is disabled and when low the Adaptation speed is enabled																	
<b>SHFT</b>	when high the 16-bit linear mode, inputs Sin, Rin, are shift right by 2 and outputs Sout, Rout are shift left by 2. This bit is ignored when 16-bit linear mode is not selected in both ports. This bit is also ignored if bit 7 of MC register is set to zero																	

<b>Address:</b> 22h Read	<b>Acoustic Echo Canceller Status Register (ASR)</b> (* Do not write to this register)																
<b>Power Up Reset 00h</b>	7	-	6	ACMUND	5	HWLNG	4	-	3	NLPDC	2	DT	1	NB	0	NBS	LSB
<b>NBS</b>	When high, the Narrowband signal has been detected in the Sin/Sout path and when low, the Narrowband signal has not been detected in the Sin/Sout path																
<b>NB</b>	LOGICAL OR of the status bit NBS + NBR from LSR Register																
<b>DT</b>	When high the Double Talk is detected and when low, the Double talk is not detected																
<b>NLPDC</b>	When high, the NLP is activated and when low the NLP is not activated																
-	RESERVED.																
<b>HWLNG</b>	When high, Howling is occurring in the loop and when low, no Howling is detected																
<b>ACMUND</b>	When high, No active signal in the Rin/Rout path																
-	RESERVED.																

<b>Address:</b> 02h Read	<b>Line Echo Canceller Status Register (LSR)</b> (* Do not write to this register)																
<b>Power Up Reset 00h</b>	-	6	-	5	-	4	-	3	NLPC	2	DT	1	NB	0	NBR	LSB	
<b>NBR</b>	When high, a narrowband signal has been detected in the Receive (Rin) path. When low no narrowband signal is not detected in the Rin path																
<b>NB</b>	This bit indicates a LOGICAL-OR of Status bits NBR + NBS (from ASR Register)																
<b>DT</b>	When high, double-talk is detected and when low double-talk is not detected																
<b>NLPC</b>	When high, NLP is activated and when low NLP is not activated																
-	RESERVED.																
-																	
-																	
--																	

<b>Address:</b> 20h R/W	<b>Receive Gain Control Register (RGC)</b>																
<b>Power Up Reset 6Dh</b>	7	-	6	-	5	-	4	-	3	G3	2	G2	1	G1	0	G0	LSB
<b>G0</b>	User Gain Control on the Rin/Rout path (Tolerance of gains: +/- 0.15 dB). The hexadecimal number represents G3 to G0 value in the table below.																
<b>G1</b>																	
<b>G2</b>																	
<b>G3</b>																	
-	RESERVED																
-																	
-																	
-																	

**Gain Values for Receive Gain Control Register Bit G3 to G0 (RGC)**

0h	-24 dB	4h	-12 dB	8h	0 dB	Ch	+12 dB
1h	-21 dB	5h	-9 dB	9h	+ 3 dB	Dh	+ 15 dB
2h	-18 dB	6h	-6 dB	Ah	+ 6 dB	Eh	+ 18 dB
3h	-15 dB	7h	-3 dB	Bh	+9 dB	Fh	+ 21 dB

<b>Address:</b> 16h Read	<b>Receive (Rin) Peak Detect Register 1 (RIPD1)</b>
<b>Power Up Reset 00h</b>	
RIPD <sub>0</sub>	<p>These peak detector registers allow the user to monitor the receive in signal (Rin) peak level at reference point R1 (see Figure #1). The information is in 16-bit 2's complement linear coded format presented in two 8 bit registers. The high byte is in Register 2 and the low byte is in Register 1.</p>
RIPD <sub>1</sub>	
RIPD <sub>2</sub>	
RIPD <sub>3</sub>	
RIPD <sub>4</sub>	
RIPD <sub>5</sub>	
RIPD <sub>6</sub>	
RIPD <sub>7</sub>	

<b>Address:</b> 17h Read	<b>Receive (Rin) Peak Detect Register 2 (RIPD2)</b>
<b>Power Up Reset 00h</b>	
RIPD <sub>8</sub>	<p>See Above Description</p>
RIPD <sub>9</sub>	
RIPD <sub>10</sub>	
RIPD <sub>11</sub>	
RIPD <sub>12</sub>	
RIPD <sub>13</sub>	
RIPD <sub>14</sub>	
RIPD <sub>15</sub>	

<b>Address:</b> 18h Read	<b>Receive (Rin) ERROR Peak Detect Register 1 (REPD1)</b>
<b>Power Up Reset 00h</b>	
REPD <sub>0</sub>	<p>These peak detector registers allow the user to monitor the error signal peak level at reference point R2 (see Figure #1). The information is in 16-bit 2's complement linear coded format presented in two 8 bit registers. The high byte is in Register 2 and the low byte is in Register 1.</p>
REPD <sub>1</sub>	
REPD <sub>2</sub>	
REPD <sub>3</sub>	
REPD <sub>4</sub>	
REPD <sub>5</sub>	
REPD <sub>6</sub>	
REPD <sub>7</sub>	

Address: 19h Read	<b>Receive (Rin) ERROR Peak Detect Register 2 (REPD2)</b>								
Power Up Reset 00h	7	6	5	4	3	2	1	0	LSB
REPD8	REPD <sub>15</sub>	REPD <sub>14</sub>	REPD <sub>13</sub>	REPD <sub>12</sub>	REPD <sub>11</sub>	REPD <sub>10</sub>	REPD <sub>9</sub>	REPD <sub>8</sub>	
REPD9	See above description								
REPD10									
REPD11									
REPD12									
REPD13									
REPD14									
REPD15									

Address: 3Ah Read	<b>Receive (Rout) Peak Detect Register 1 (ROPD1)</b>								
Power Up Reset 00h	7	6	5	4	3	2	1	0	LSB
ROPD <sub>0</sub>	ROPD <sub>7</sub>	ROPD <sub>6</sub>	ROPD <sub>5</sub>	ROPD <sub>4</sub>	ROPD <sub>3</sub>	ROPD <sub>2</sub>	ROPD <sub>1</sub>	ROPD <sub>0</sub>	
ROPD <sub>1</sub>	These peak detector registers allow the user to monitor the receive out signal (Rout) peak level at reference point R3 (see Figure #1). The information is in 16-bit 2's complement linear coded format presented in two 8 bit registers. The high byte is in Register 2 and the low byte is in Register 1.								
ROPD <sub>2</sub>									
ROPD <sub>3</sub>									
ROPD <sub>4</sub>									
ROPD <sub>5</sub>									
ROPD <sub>6</sub>									
ROPD <sub>7</sub>									

Address: 3Bh Read	<b>Receive (Rout) Peak Detect Register 2 (ROPD2)</b>								
Power Up Reset 00h	7	6	5	4	3	2	1	0	LSB
ROPD <sub>8</sub>	ROPD <sub>15</sub>	ROPD <sub>14</sub>	ROPD <sub>13</sub>	ROPD <sub>12</sub>	ROPD <sub>11</sub>	ROPD <sub>10</sub>	ROPD <sub>9</sub>	ROPD <sub>8</sub>	
ROPD <sub>9</sub>	See Above description								
ROPD <sub>10</sub>									
ROPD <sub>11</sub>									
ROPD <sub>12</sub>									
ROPD <sub>13</sub>									
ROPD <sub>14</sub>									
ROPD <sub>15</sub>									

<b>Address:</b> 36h Read	<b>Send (Sin) Peak Detect Register 1 (SIPD1)</b>
<b>Power Up Reset 00h</b>	7 <span style="border: 1px solid black; padding: 2px;">SIPD<sub>7</sub></span> 6 <span style="border: 1px solid black; padding: 2px;">SIPD<sub>6</sub></span> 5 <span style="border: 1px solid black; padding: 2px;">SIPD<sub>5</sub></span> 4 <span style="border: 1px solid black; padding: 2px;">SIPD<sub>4</sub></span> 3 <span style="border: 1px solid black; padding: 2px;">SIPD<sub>3</sub></span> 2 <span style="border: 1px solid black; padding: 2px;">SIPD<sub>2</sub></span> 1 <span style="border: 1px solid black; padding: 2px;">SIPD<sub>1</sub></span> 0 <span style="border: 1px solid black; padding: 2px;">SIPD<sub>0</sub></span> MSB <span style="float: right;">LSB</span>
SIPD <sub>0</sub>	These peak detector registers allow the user to monitor the receive in signal (Sin) peak level at reference point S1 (see Figure #1). The information is in 16-bit 2's complement linear coded format presented in two 8 bit registers. The high byte is in Register 2 and the low byte is in Register 1.
SIPD <sub>1</sub>	
SIPD <sub>2</sub>	
SIPD <sub>3</sub>	
SIPD <sub>4</sub>	
SIPD <sub>5</sub>	
SIPD <sub>6</sub>	
SIPD <sub>7</sub>	

<b>Address:</b> 37h Read	<b>Send (Sin) Peak Detect Register 2 (SIPD2)</b>
<b>Power Up Reset 00h</b>	7 <span style="border: 1px solid black; padding: 2px;">SIPD<sub>15</sub></span> 6 <span style="border: 1px solid black; padding: 2px;">SIPD<sub>14</sub></span> 5 <span style="border: 1px solid black; padding: 2px;">SIPD<sub>13</sub></span> 4 <span style="border: 1px solid black; padding: 2px;">SIPD<sub>12</sub></span> 3 <span style="border: 1px solid black; padding: 2px;">SIPD<sub>11</sub></span> 2 <span style="border: 1px solid black; padding: 2px;">SIPD<sub>10</sub></span> 1 <span style="border: 1px solid black; padding: 2px;">SIPD<sub>9</sub></span> 0 <span style="border: 1px solid black; padding: 2px;">SIPD<sub>8</sub></span> MSB <span style="float: right;">LSB</span>
SIPD <sub>8</sub>	See above description
SIPD <sub>9</sub>	
SIPD <sub>10</sub>	
SIPD <sub>11</sub>	
SIPD <sub>12</sub>	
SIPD <sub>13</sub>	
SIPD <sub>14</sub>	
SIPD <sub>15</sub>	

<b>Address:</b> 38h Read	<b>Send ERROR Peak Detect Register 1 (SEPD1)</b>
<b>Power Up Reset 00h</b>	7 <span style="border: 1px solid black; padding: 2px;">SEPD<sub>7</sub></span> 6 <span style="border: 1px solid black; padding: 2px;">SEPD<sub>6</sub></span> 5 <span style="border: 1px solid black; padding: 2px;">SEPD<sub>5</sub></span> 4 <span style="border: 1px solid black; padding: 2px;">SEPD<sub>4</sub></span> 3 <span style="border: 1px solid black; padding: 2px;">SEPD<sub>3</sub></span> 2 <span style="border: 1px solid black; padding: 2px;">SEPD<sub>2</sub></span> 1 <span style="border: 1px solid black; padding: 2px;">SEPD<sub>1</sub></span> 0 <span style="border: 1px solid black; padding: 2px;">SEPD<sub>0</sub></span> MSB <span style="float: right;">LSB</span>
SEPD <sub>0</sub>	These peak detector registers allow the user to monitor the error signal peak level in the send path at reference point S2 (see Figure #1). The information is in 16-bit 2's complement linear coded format presented in two 8 bit registers. The high byte is in Register 2 and the low byte is in Register 1.
SEPD <sub>1</sub>	
SEPD <sub>2</sub>	
SEPD <sub>3</sub>	
SEPD <sub>4</sub>	
SEPD <sub>5</sub>	
SEPD <sub>6</sub>	
SEPD <sub>7</sub>	

<b>Address:</b> 39h Read	<b>Send ERROR Peak Detect Register 2 (SEPD2)</b>
<b>Power Up Reset 00h</b>	MSB 7 <b>SEPD<sub>15</sub></b> 6 <b>SEPD<sub>14</sub></b> 5 <b>SEPD<sub>13</sub></b> 4 <b>SEPD<sub>12</sub></b> 3 <b>SEPD<sub>11</sub></b> 2 <b>SEPD<sub>10</sub></b> 1 <b>SEPD<sub>9</sub></b> 0 <b>SEPD<sub>8</sub></b> LSB
<b>SEPD8</b>	See Above description
<b>SEPD9</b>	
<b>SEPD10</b>	
<b>SEPD11</b>	
<b>SEPD12</b>	
<b>SEPD13</b>	
<b>SEPD14</b>	
<b>SEPD15</b>	

<b>Address:</b> 1Ah Read	<b>Send (Sout) Peak Detect Register 1 (SOPD1)</b>
<b>Power Up Reset 00h</b>	MSB 7 <b>SOPD<sub>7</sub></b> 6 <b>SOPD<sub>6</sub></b> 5 <b>SOPD<sub>5</sub></b> 4 <b>SOPD<sub>4</sub></b> 3 <b>SOPD<sub>3</sub></b> 2 <b>SOPD<sub>2</sub></b> 1 <b>SOPD<sub>1</sub></b> 0 <b>SOPD<sub>0</sub></b> LSB
<b>SOPD<sub>0</sub></b>	These peak detector registers allow the user to monitor the Send out signal (Sout) peak level at reference point S3 (see Figure #1). The information is in 16-bit 2's complement linear coded format presented in two 8 bit registers. The high byte is in Register 2 and the low byte is in Register 1.
<b>SOPD<sub>1</sub></b>	
<b>SOPD<sub>2</sub></b>	
<b>SOPD<sub>3</sub></b>	
<b>SOPD<sub>4</sub></b>	
<b>SOPD<sub>5</sub></b>	
<b>SOPD<sub>6</sub></b>	
<b>SOPD<sub>7</sub></b>	

<b>Address:</b> 1Bh Read	<b>Send (Sout) Peak Detect Register 2 (SOPD2)</b>
<b>Power Up Reset 00h</b>	MSB 7 <b>SOPD<sub>15</sub></b> 6 <b>SOPD<sub>14</sub></b> 5 <b>SOPD<sub>13</sub></b> 4 <b>SOPD<sub>12</sub></b> 3 <b>SOPD<sub>11</sub></b> 2 <b>SOPD<sub>10</sub></b> 1 <b>SOPD<sub>9</sub></b> 0 <b>SOPD<sub>8</sub></b> LSB
<b>SOPD<sub>8</sub></b>	See Above description
<b>SOPD<sub>9</sub></b>	
<b>SOPD<sub>10</sub></b>	
<b>SOPD<sub>11</sub></b>	
<b>SOPD<sub>12</sub></b>	
<b>SOPD<sub>13</sub></b>	
<b>SOPD<sub>14</sub></b>	
<b>SOPD<sub>15</sub></b>	

Address: 3Ch R/W	<b>Acoustic Echo Canceller Adaptation Speed Register 1 (A_AS1)</b>									
Power Up Reset 00h	7	6	5	4	3	2	1	0	MSB	LSB
A_AS <sub>0</sub>	<p>This register allows the user to program control the adaptation speed of the Acoustic Echo Canceller. This register value changes dynamically when the 'ASC-' bit in the Acoustic Echo Canceller Control Register is low. The 'ASC-' bit must be 1 when this register is under user control. The valid range is from 0000h to 7FFFh. The high byte is in Register 2 and the low byte is in Register 1. Smaller values correspond to slower adaptation speed.</p>									
A_AS <sub>1</sub>										
A_AS <sub>2</sub>										
A_AS <sub>3</sub>										
A_AS <sub>4</sub>										
A_AS <sub>5</sub>										
A_AS <sub>6</sub>										
A_AS <sub>7</sub>										
Address: 3Dh R/W	<b>Acoustic Echo Canceller Adaptation Speed Register 2 (A_AS2)</b>									
Power Up Reset 10h	7	6	5	4	3	2	1	0	MSB	LSB
A_AS <sub>8</sub>	<p>See Above description</p>									
A_AS <sub>9</sub>										
A_AS <sub>10</sub>										
A_AS <sub>11</sub>										
A_AS <sub>12</sub>										
A_AS <sub>13</sub>										
A_AS <sub>14</sub>										
A_AS <sub>15</sub>										
Address: 1Ch R/W	<b>Line Echo Canceller Adaptation Speed Register 1 (L_AS1)</b>									
Power Up Reset 00h	7	6	5	4	3	2	1	0	MSB	LSB
L_AS <sub>0</sub>	<p>This register allows the user to program control the adaptation speed of the Line Echo Canceller. This register value changes dynamically when the 'ASC-' bit in the Acoustic Echo Canceller Control Register is low. The 'ASC-' bit must be 1 when this register is under user control. The valid range is from 0000h to 7FFFh. The high byte is in Register 2 and the low byte is in Register 1. Smaller values correspond to slower adaptation speed.</p>									
L_AS <sub>1</sub>										
L_AS <sub>2</sub>										
L_AS <sub>3</sub>										
L_AS <sub>4</sub>										
L_AS <sub>5</sub>										
L_AS <sub>6</sub>										
L_AS <sub>7</sub>										

Address: 1Dh Read	<b>Line Echo Canceller Adaptation Speed Register 2 (L_AS2)</b>								
Power Up Reset 08h	7	6	5	4	3	2	1	0	LSB
L_AS <sub>8</sub>	See Above description								
L_AS <sub>9</sub>									
L_AS <sub>10</sub>									
L_AS <sub>11</sub>									
L_AS <sub>12</sub>									
L_AS <sub>13</sub>									
L_AS <sub>14</sub>									
L_AS <sub>15</sub>									

Address: 24h R/W	<b>Rout Limiter Register 1 (RL1)</b>								
Power Up Reset 80h	7	6	5	4	3	2	1	0	LSB
-	L <sub>0</sub>	-	-	-	-	-	-	-	
-	RESERVED								
-									
-									
-									
-									
-									
L <sub>0</sub>	This bit is used in conjunction with Rout Limiter Register 2. (See description below.)								

Address: 25h R/W	<b>Rout Limiter Register 2 (RL2)</b>								
Power Up Reset 3Eh	7	6	5	4	3	2	1	0	LSB
L <sub>1</sub>	L <sub>8</sub>	L <sub>7</sub>	L <sub>6</sub>	L <sub>5</sub>	L <sub>4</sub>	L <sub>3</sub>	L <sub>2</sub>	L <sub>1</sub>	
L <sub>2</sub>	In conjunction with bit 7 (L <sub>0</sub> ) of the above (RL1) register, this register (RL2) allows the user to program the output Limiter threshold value in the Rout path.  Default value is (1f40)h which is equal to 3.14 dBmo Maximum value is (7FC0)h = 15 dBmo Minimum value is (0040)h = -38 dBmo								
L <sub>3</sub>									
L <sub>4</sub>									
L <sub>5</sub>									
L <sub>6</sub>									
L <sub>7</sub>									
L <sub>8</sub>									

<b>Address:</b> 26h R/W	<b>Sout Limiter Register (SL)</b>									
<b>Power Up Reset</b> 3Dh	7	6	5	4	3	2	1	0	MSB	LSB
-	L <sub>4</sub>	L <sub>3</sub>	L <sub>2</sub>	L <sub>1</sub>	L <sub>0</sub>	-	-	-		
-	RESERVED									
L <sub>0</sub>	This register allows the user to program the output Limiter threshold value in the Rout path Default value is (1f40)h which is equal to 3.14 dBmo Maximum value is (7F40)h									
L <sub>1</sub>										
L <sub>2</sub>										
L <sub>3</sub>										
L <sub>4</sub>										

<b>Address:</b> 03h Read	<b>Firmware Revision Code Register (FRC)</b>									
<b>Power Up Reset</b> 00h	7	6	5	4	3	2	1	0	MSB	LSB
-	FRC <sub>2</sub>	FRC <sub>1</sub>	FRC <sub>0</sub>	-	-	-	-	-		
-	RESERVED									
FRC <sub>0</sub>	Revision code of the firmware program currently being run (default=rom=00).									
FRC <sub>1</sub>										
FRC <sub>2</sub>										

<b>Address:</b> 3fh R / W	<b>Bootload RAM Control Register (BRC)</b>									
<b>Power Up Reset</b> 00h	7	6	5	4	3	2	1	0	MSB	LSB
C <sub>0</sub>	-	-	-	-	RAM_ROMb	BOOT	-	-		
C <sub>1</sub>	RESERVED. Must be set to zero.									
C <sub>2</sub>	RESERVED. Must be set to zero.									
C <sub>3</sub>	BOOT bit. When high, puts device in bootload mode. When low, bootload is disabled.									
-	RAM_ROMb bit. When high, device executes from RAM. When low, device executes from ROM.									
-	RESERVED									
-	RESERVED									

<b>Address:</b> 07h Read	<b>Bootload RAM Signature Register (SIG)</b>								
<b>Power Up Reset FFh</b>	7	6	5	4	3	2	1	0	LSB
<b>SIG<sub>7</sub></b>	MSB	SIG <sub>7</sub>	SIG <sub>6</sub>	SIG <sub>5</sub>	SIG <sub>4</sub>	SIG <sub>3</sub>	SIG <sub>2</sub>	SIG <sub>1</sub>	SIG <sub>0</sub>
<b>SIG<sub>6</sub></b>	<p>This register provides the signature of the bootloaded data to verify error-free delivery into the device.                      Note: this register is only accessible if BOOT bit is high (bootload mode enabled) in the above BRC register. While bootload is disabled, the register value is held constant at its reset seed value of FFh.</p>								
<b>SIG<sub>5</sub></b>									
<b>SIG<sub>4</sub></b>									
<b>SIG<sub>3</sub></b>									
<b>SIG<sub>2</sub></b>									
<b>SIG<sub>1</sub></b>									
<b>SIG<sub>0</sub></b>									

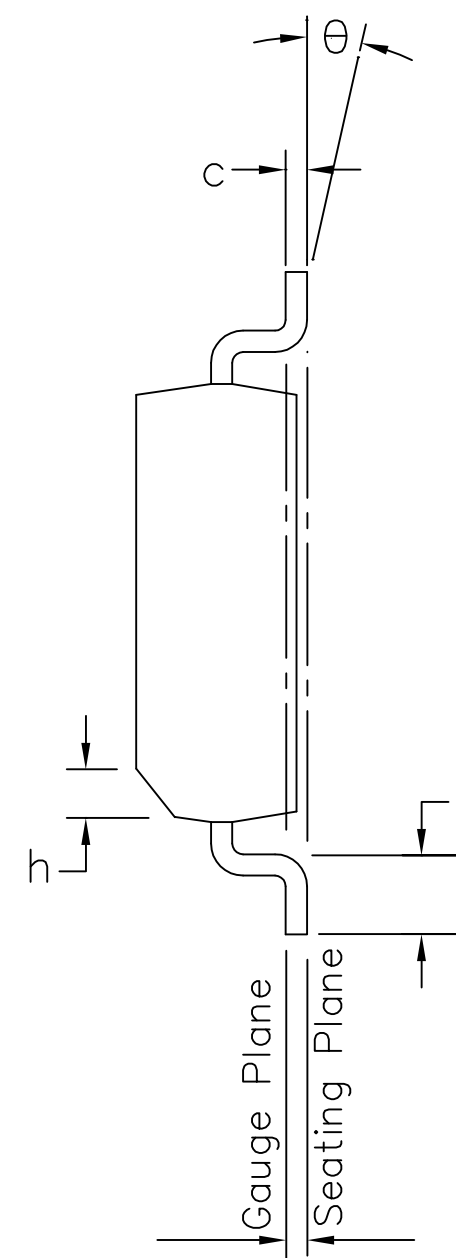
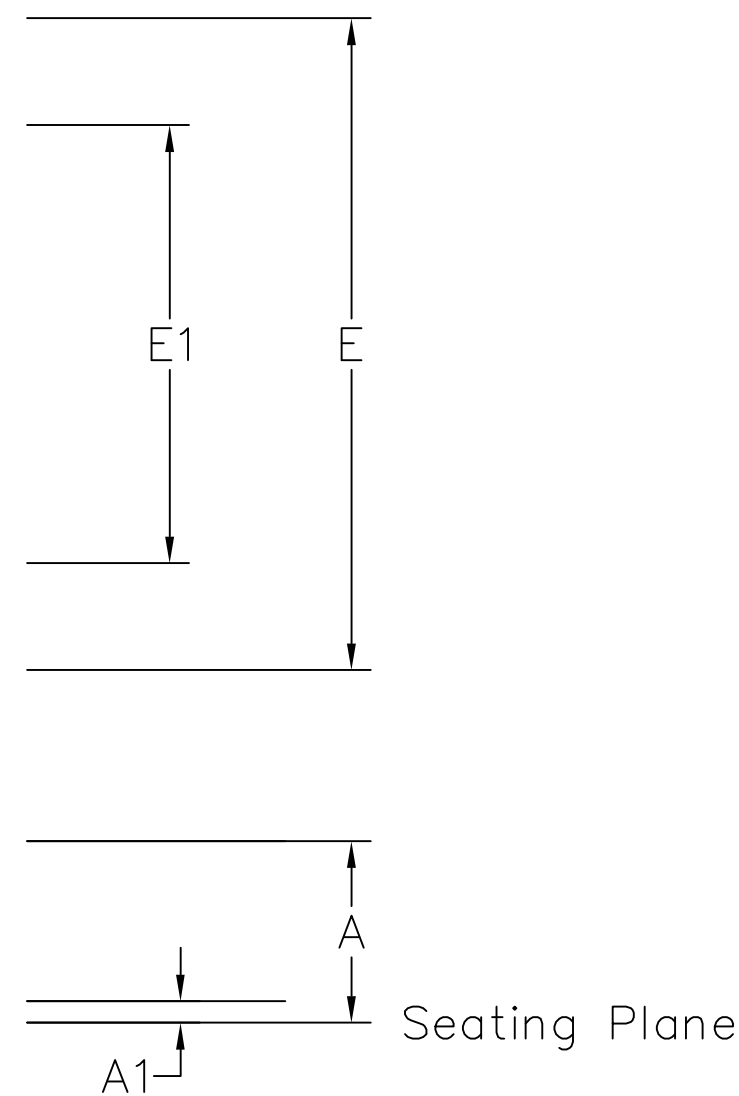
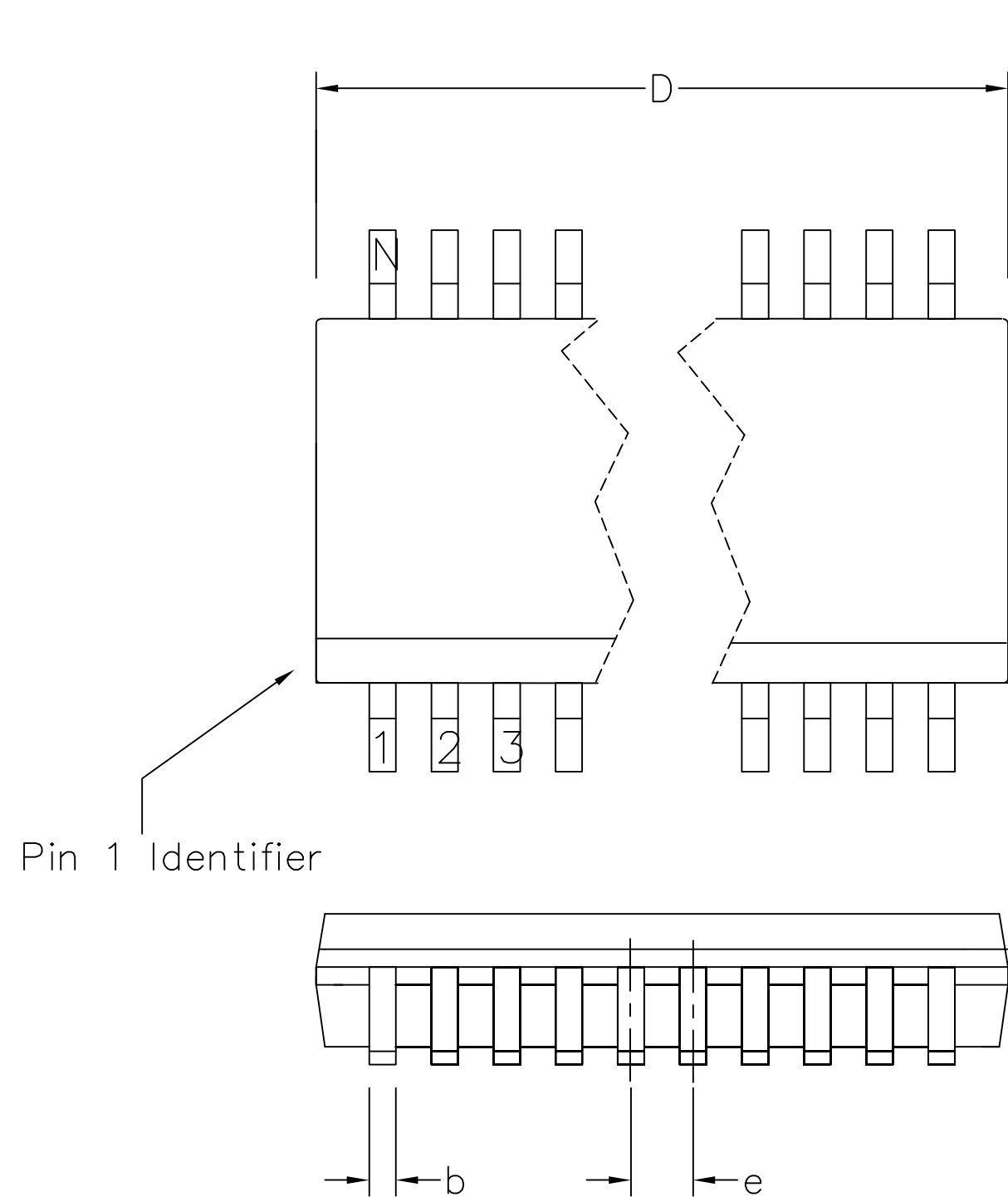

Symbol	Altern. Dimensions in inches		Control Dimensions in millimetres	
	MIN	MAX	MIN	MAX
A	0.096	0.104	2.44	2.64
A1	0.004	0.012	0.10	0.30
D	0.598	0.612	15.20	15.40
E1	0.291	0.299	7.40	7.60
E	0.398	0.414	10.11	10.51
L	0.016	0.050	0.40	1.27
e	0.0315	BSC.	0.80	BSC.
b	0.011	0.020	0.28	0.51
c	0.009	0.013	0.23	0.32
$\theta$	0°	8°	0°	8°
h	0.018	0.0216	0.45	0.55
Pin features				
N	36			
NON JEDEC STANDARD DRAWING				

Notes:

1. The chamfer on the body is optional. If it is not present, a visual index feature, e.g. a dot, must be located at pin 1 position.
2. Controlling dimensions are in millimeters
3. D & E1 do not include mould flash or protrusion. But do include mold mismatch.
4. Dimension E1 does not include inter-lead flash or protrusion.
5. Dimension b does not include dambar protrusion/intrusion.
6. Not to Scale

© Zarlink Semiconductor 2003 All rights reserved.

ISSUE	1			
ACN				
DATE	09-02-04			
APPRD.				



Previous package codes

Q

Package Code DG

Package Outline for 36 lead QSOP, 300 mil (7.5mm) Body width

103461

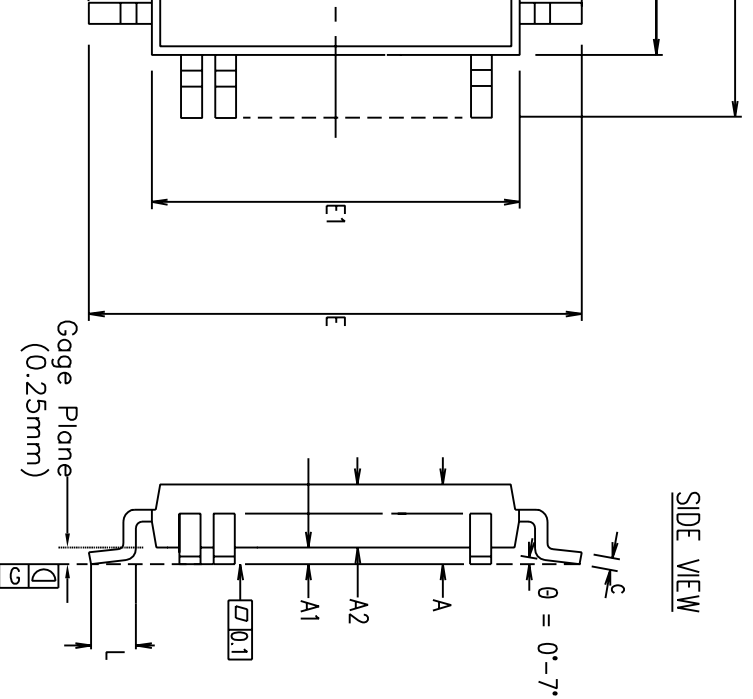

Symbol	Control Dimensions in millimetres		Altern. Dimensions in inches	
	MIN	MAX	MIN	MAX
A	---	1.20	---	0.047
A1	0.05	0.15	0.002	0.006
A2	0.95	1.05	0.037	0.041
D	9.00	BSC	0.354	BSC
D1	7.00	BSC	0.276	BSC
E	9.00	BSC	0.354	BSC
E1	7.00	BSC	0.276	BSC
L	0.45	0.75	0.018	0.030
e	0.50	BSC	0.020	BSC
b	0.17	0.27	0.007	0.011
c	0.09	0.20	0.004	0.008
Pin features				
N	48			
ND	12			
NE	12			
NOTE	SQUARE			

Conforms to JEDEC MS-026 ABC Iss. C

ers.  
fer, dot or both.  
smaller than the bottom package body size by a max. of 0.15 mm.  
mould protrusion.  
protrusion.  
e G, to be 0.08 mm max.  
le for e-PAD Packages only.  
dimension.  
ll be within 0.30mm of nominal pad size.

This drawing supersedes 418/ED/51612/002 (Swindon)

	Previous package codes	Package Code	<b>QD</b> Package Outline for 48 lead TQFP / E-Pad TQFP (7x7x1.0mm) 2.0mm Footprint
	TP / TH / F		
			<b>GPD00249</b>



**For more information about all Zarlink products  
visit our Web Site at  
[www.zarlink.com](http://www.zarlink.com)**

Information relating to products and services furnished herein by Zarlink Semiconductor Inc. or its subsidiaries (collectively "Zarlink") is believed to be reliable. However, Zarlink assumes no liability for errors that may appear in this publication, or for liability otherwise arising from the application or use of any such information, product or service or for any infringement of patents or other intellectual property rights owned by third parties which may result from such application or use. Neither the supply of such information or purchase of product or service conveys any license, either express or implied, under patents or other intellectual property rights owned by Zarlink or licensed from third parties by Zarlink, whatsoever. Purchasers of products are also hereby notified that the use of product in certain ways or in combination with Zarlink, or non-Zarlink furnished goods or services may infringe patents or other intellectual property rights owned by Zarlink.

This publication is issued to provide information only and (unless agreed by Zarlink in writing) may not be used, applied or reproduced for any purpose nor form part of any order or contract nor to be regarded as a representation relating to the products or services concerned. The products, their specifications, services and other information appearing in this publication are subject to change by Zarlink without notice. No warranty or guarantee express or implied is made regarding the capability, performance or suitability of any product or service. Information concerning possible methods of use is provided as a guide only and does not constitute any guarantee that such methods of use will be satisfactory in a specific piece of equipment. It is the user's responsibility to fully determine the performance and suitability of any equipment using such information and to ensure that any publication or data used is up to date and has not been superseded. Manufacturing does not necessarily include testing of all functions or parameters. These products are not suitable for use in any medical products whose failure to perform may result in significant injury or death to the user. All products and materials are sold and services provided subject to Zarlink's conditions of sale which are available on request.

Purchase of Zarlink's I<sup>2</sup>C components conveys a licence under the Philips I<sup>2</sup>C Patent rights to use these components in and I<sup>2</sup>C System, provided that the system conforms to the I<sup>2</sup>C Standard Specification as defined by Philips.



Zarlink, ZL, the Zarlink Semiconductor logo and the Legerity logo and combinations thereof, VoiceEdge, VoicePort, SLAC, ISLIC, ISLAC and VoicePath are trademarks of Zarlink Semiconductor Inc.

**TECHNICAL DOCUMENTATION - NOT FOR RESALE**

---

## Looking for pricing, stock, or lifecycle information?

Click below to explore more details on WIN SOURCE:

-  [View MT93L16AQ1 on WIN SOURCE](#)
-  [Microsemi Corporation](#) Information

## Optimize Your Supply Chain with WIN SOURCE Solutions

-  Global Sourcing Solution
-  Obsolete Management
-  Cost Control Management
-  Shortage Management
-  Alternative Solution
-  Excess Inventory Management