



**THE DATASHEET OF  
AD7814ARM-REEL7**



### FEATURES

**10-Bit Temperature-to-Digital Converter**  
**-55°C to +125°C Operating Temperature Range**  
**±2°C Accuracy**  
**SPI- and DSP-Compatible Serial Interface**  
**Shutdown Mode**  
**Space-Saving SOT-23 Package**

### APPLICATIONS

**Hard Disk Drives**  
**Personal Computers**  
**Electronic Test Equipment**  
**Office Equipment**  
**Domestic Appliances**  
**Process Control**

### GENERAL DESCRIPTION

The AD7814 is a complete temperature monitoring system in a SOT-23 package or 8-lead MSOP package. It contains a band gap temperature sensor and 10-bit ADC to monitor and digitize the temperature reading to a resolution of 0.25°C.

The AD7814 has a flexible serial interface that allows easy interfacing to most microcontrollers. The interface is compatible with SPI®, QSPI™, and MICROWIRE™ protocol, and is also compatible with DSPs. The part features a standby mode that is controlled via the serial interface.

The AD7814's wide supply voltage range, low supply current, and SPI-compatible interface make it ideal for a variety of applications, including personal computers, office equipment, and domestic appliances.

Purchase of licensed I<sup>2</sup>C components of Analog Devices or one of its sublicensed Associated Companies conveys a license for the purchaser under the Philips I<sup>2</sup>C Patent Rights to use these components in an I<sup>2</sup>C system, provided that the system conforms to the I<sup>2</sup>C Standard Specification as defined by Philips.

### REV. E

Information furnished by Analog Devices is believed to be accurate and reliable. However, no responsibility is assumed by Analog Devices for its use, nor for any infringements of patents or other rights of third parties that may result from its use. No license is granted by implication or otherwise under any patent or patent rights of Analog Devices. Trademarks and registered trademarks are the property of their respective owners.

### FUNCTIONAL BLOCK DIAGRAM

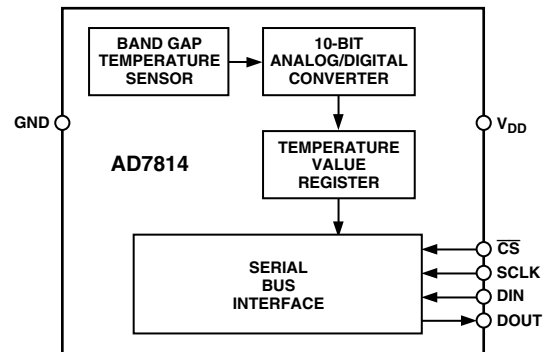

### PRODUCT HIGHLIGHTS

1. The AD7814 has an on-chip temperature sensor that allows an accurate measurement of the ambient temperature. The measurable temperature range is -55°C to +125°C, with a ±2°C temperature accuracy.
2. Supply voltage of 2.7 V to 5.5 V
3. Space-saving 6-lead SOT-23 package and 8-lead MSOP package
4. 10-bit temperature reading to 0.25°C resolution
5. Standby mode that reduces the current consumption to 1 µA

# AD7814—SPECIFICATIONS<sup>1</sup> ( $T_A = T_{MIN}$ to $T_{MAX}$ , $V_{DD} = 2.7$ V to 5.5 V, unless otherwise noted.)

Parameter	Min	Typ	Max	Unit	Test Conditions/Comments
<b>TEMPERATURE SENSOR AND ADC</b>					
Accuracy			±2.0	°C	$T_A = 0^\circ\text{C}$ to $85^\circ\text{C}$ . $V_{DD} = 3$ V to 5.5 V <sup>2</sup> $T_A = -40^\circ\text{C}$ to $0^\circ\text{C}$ . $V_{DD} = 3$ V to 5.5 V <sup>2</sup> $T_A = -55^\circ\text{C}$ to $+125^\circ\text{C}$ . $V_{DD} = 3$ V to 5.5 V
			±2.5	°C	
		±2.0	±3.5	°C	
Resolution		10		Bits	
Update Rate, $t_R$		400		μs	
Temperature Conversion Time		25		μs	
<b>SUPPLIES</b>					
Supply Voltage	2.7		5.5	V	For Specified Performance          $V_{DD} = 3$ V. Using Normal Mode $V_{DD} = 3$ V. Using Shutdown Mode
Supply Current					
Normal Mode		250	400	μA	
Shutdown Mode ( $V_{DD} = 5$ V)		1.23	3	μA	
Shutdown Mode ( $V_{DD} = 3$ V)		0.43	1	μA	
Power Dissipation		80		μW	
Power Dissipation					
1 sps		3.7		μW	
10 sps		3.9		μW	
100 sps		5.8		μW	
<b>DIGITAL INPUT<sup>3</sup></b>					
Input High Voltage, $V_{IH}$	2.4			V	$V_{IN} = 0$ V to $V_{DD}$ All Digital Inputs
Input Low Voltage, $V_{IL}$			0.8	V	
Input Current, $I_{IN}$			±1	μA	
Input Capacitance, $C_{IN}$			10	pF	
<b>DIGITAL OUTPUT<sup>3</sup></b>					
Output High Voltage, $V_{OH}$	$V_{DD} - 0.3$ V				$I_{SOURCE} = I_{SINK} = 200$ μA $I_{OL} = 200$ μA
Output Low Voltage, $V_{OL}$			0.4	V	
Output Capacitance, $C_{OUT}$			50	pF	

## NOTES

<sup>1</sup>All specifications apply for  $-55^\circ\text{C}$  to  $+125^\circ\text{C}$  unless otherwise stated.

<sup>2</sup>For  $V_{DD} = 2.7$  V to 3 V and  $T_A = -40^\circ\text{C}$  to  $+85^\circ\text{C}$ , the typical temperature error is  $\pm 2^\circ\text{C}$ .

<sup>3</sup>Guaranteed by design and characterization, not production tested.

Specifications subject to change without notice.

## TIMING CHARACTERISTICS<sup>1, 2, 3</sup> ( $T_A = T_{MIN}$ to $T_{MAX}$ , $V_{DD} = 2.7$ V to 5.5 V, unless otherwise noted.)

Parameter	Limit	Unit	Comments
$t_1$	0	ns min	$\overline{CS}$ to SCLK Setup Time
$t_2$	50	ns min	SCLK High Pulse Width
$t_3$	50	ns min	SCLK Low Pulse Width
$t_4^4$	35	ns max	Data Access Time After SCLK Falling Edge
$t_5$	20	ns min	Data Setup Time Prior to SCLK Rising Edge
$t_6$	0	ns min	Data Hold Time After SCLK Rising Edge
$t_7$	0	ns min	$\overline{CS}$ to SCLK Hold Time
$t_8^4$	40	ns max	$\overline{CS}$ to DOUT High Impedance

## NOTES

<sup>1</sup>Guaranteed by design and characterization, not production tested.

<sup>2</sup>All input signals are specified with  $t_r = t_f = 5$  ns (10% to 90% of  $V_{DD}$ ) and timed from a voltage level of 1.6 V.

<sup>3</sup>See Figure 2.

<sup>4</sup>Measured with the load circuit of Figure 1.

Specifications subject to change without notice.

### ABSOLUTE MAXIMUM RATINGS\*

$V_{DD}$ to GND	-0.3 V to +7 V
Digital Input Voltage to GND	-0.3 V to $V_{DD} + 0.3$ V
Digital Output Voltage to GND	-0.3 V to $V_{DD} + 0.3$ V
Operating Temperature Range	-55°C to +125°C
Storage Temperature Range	-65°C to +150°C
Junction Temperature	150°C
SOT-23, Power Dissipation	450 mW
$\theta_{JA}$ Thermal Impedance	240°C/W
Lead Temperature, Soldering	
Vapor Phase (60 sec)	215°C
Infrared (15 sec)	220°C
MSOP Package, Power Dissipation	450 mW
$\theta_{JA}$ Thermal Impedance	206°C/W
Lead Temperature, Soldering	
Vapor Phase (60 sec)	215°C
Infrared (15 sec)	220°C

\*Stresses above those listed under Absolute Maximum Ratings may cause permanent damage to the device. This is a stress rating only; functional operation of the device at these or any other conditions above those indicated in the operational section of this specification is not implied. Exposure to absolute maximum rating conditions for extended periods may affect device reliability.

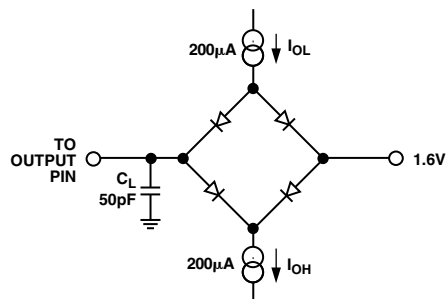

Figure 1. Load Circuit for Data Access Time and Bus Relinquish Time

### ORDERING GUIDE

Model	Temperature Range	Temperature Error <sup>1</sup>	Package Description	Package Option	Branding Information
AD7814ART-500RL7	-55°C to +125°C	±2°C	6-Lead SOT-23	RT-6	CAA
AD7814ART-REEL	-55°C to +125°C	±2°C	6-Lead SOT-23	RT-6	CAA
AD7814ART-REEL7	-55°C to +125°C	±2°C	6-Lead SOT-23	RT-6	CAA
AD7814ARTZ-500RL7 <sup>2</sup>	-55°C to +125°C	±2°C	6-Lead SOT-23	RT-6	CAA
AD7814ARTZ-REEL <sup>2</sup>	-55°C to +125°C	±2°C	6-Lead SOT-23	RT-6	CAA
AD7814ARTZ-REEL7 <sup>2</sup>	-55°C to +125°C	±2°C	6-Lead SOT-23	RT-6	CAA
AD7814ARM	-55°C to +125°C	±2°C	8-Lead MSOP	RM-8	CAA
AD7814ARM-REEL	-55°C to +125°C	±2°C	8-Lead MSOP	RM-8	CAA
AD7814ARM-REEL7	-55°C to +125°C	±2°C	8-Lead MSOP	RM-8	CAA
AD7814ARMZ <sup>2</sup>	-55°C to +125°C	±2°C	8-Lead MSOP	RM-8	CAA
AD7814ARMZ-REEL <sup>2</sup>	-55°C to +125°C	±2°C	8-Lead MSOP	RM-8	CAA
AD7814ARMZ-REEL7 <sup>2</sup>	-55°C to +125°C	±2°C	8-Lead MSOP	RM-8	CAA

<sup>1</sup>Temperature error is over 0°C to 85°C temperature range.

<sup>2</sup>Z = Pb-free part

### CAUTION

ESD (electrostatic discharge) sensitive device. Electrostatic charges as high as 4000 V readily accumulate on the human body and test equipment and can discharge without detection. Although the AD7814 features proprietary ESD protection circuitry, permanent damage may occur on devices subjected to high energy electrostatic discharges. Therefore, proper ESD precautions are recommended to avoid performance degradation or loss of functionality.



# AD7814

## PIN FUNCTION DESCRIPTIONS

Pin Mnemonic	SOT-23 Pin No.	MSOP Pin No.	Description
GND	1	7	Analog and Digital Ground
DIN	2	6	Serial Data Input. Serial data to be loaded to the part's control register is provided on this input. Data is clocked into the control register on the rising edge of SCLK.
V <sub>DD</sub>	3	5	Positive Supply Voltage, 2.7 V to 5.5 V
SCLK	4	4	Serial Clock Input. This is the clock input for the serial port. The serial clock is used to clock data out of the temperature value register of the AD7814 and to clock data into the control register on the part.
$\overline{\text{CS}}$	5	3	Chip Select Input. Logic input. The device is selected when this input is low. The SCLK input is disabled when this pin is high.
DOUT	6	2	Serial Data Output. Logic output. Data is clocked out of the temperature value register at this pin. Data is clocked out on the falling edge of SCLK.
NC		1, 8	No Connect

## PIN CONFIGURATIONS



### CIRCUIT INFORMATION

The AD7814 is a 10-bit digital temperature sensor. The part houses an on-chip temperature sensor, a 10-bit A/D converter, a reference, and serial interface logic functions in a SOT-23 package. The A/D converter section consists of a conventional successive-approximation converter based around a capacitor DAC. The parts are capable of running on a 2.7 V to 5.5 V power supply.

The on-chip temperature sensor allows an accurate measurement of the ambient device temperature to be made. The working measurement range of the AD7814 is  $-55^{\circ}\text{C}$  to  $+125^{\circ}\text{C}$ .

### CONVERTER DETAILS

The conversion clock for the part is internally generated so no external clock is required except when reading from and writing to the serial port. In normal mode, an internal clock oscillator runs the automatic conversion sequence. A conversion is initiated approximately every 350  $\mu\text{s}$ . At this time, the part wakes up and performs a temperature conversion. This temperature conversion typically takes 25  $\mu\text{s}$ , at which time the part automatically shuts down. The result of the most recent temperature conversion is available in the serial output register at any time. Once the conversion is finished, an internal oscillator starts counting and is designed to time out every 350  $\mu\text{s}$ . The AD7814 then powers up and does a conversion. Please note that if the  $\overline{\text{CS}}$  is brought low every 350  $\mu\text{s}$  ( $\pm 30\%$ ), then the same temperature value will be output onto the DOUT line every time without changing. It is recommended that the  $\overline{\text{CS}}$  line is not brought low every 350  $\mu\text{s}$  ( $\pm 30\%$ ). The  $\pm 30\%$  covers process variation. The  $\overline{\text{CS}}$  should become active (high to low) outside this range.

The device is designed to autoconvert every 350  $\mu\text{s}$ . If the AD7814 is accessed during the conversion process, an internal signal is generated to prevent any update of the temperature value register during the conversion. Otherwise the user could read back spurious data. The design of this feature results in this internal lockout signal being reset only at the start of the next autoconversion. Therefore, if the  $\overline{\text{CS}}$  line goes active before the internal lockout signal has been reset to its inactive mode, the internal lockout signal will not be reset. To ensure that no lockout signal is set, bring the  $\overline{\text{CS}}$  low at a greater or less time than 350  $\mu\text{s}$  ( $\pm 30\%$ ). This will mean that the AD7814 is not interrupted during a conversion process. The AD7814 can be placed in a shutdown mode, via the control register, in which case the on-chip oscillator is shut down and no further conversions are initiated until the AD7814 is taken out of shutdown mode. The conversion result from the last conversion prior to shutdown can still be read from the AD7814 even when it is in shutdown mode.

In the automatic conversion mode, every time a read or write operation takes place, the internal clock oscillator is restarted at the end of the read or write operation. The result of the conversion is typically available 25  $\mu\text{s}$  later. Similarly, when the part is taken out of shutdown mode, the internal clock oscillator is restarted and the conversion result is typically available

25  $\mu\text{s}$  later. Reading from the device before conversion is complete will provide the same set of data.

### TEMPERATURE VALUE REGISTER

The temperature value register is a read-only register that stores the temperature reading from the ADC in 10-bit twos complement format. The temperature data format is shown in Table I. This shows the full theoretical range of the ADC from  $-128^{\circ}\text{C}$  to  $+127^{\circ}\text{C}$ , but in practice the temperature measurement range is limited to the operating temperature range of the device ( $-55^{\circ}\text{C}$  to  $+125^{\circ}\text{C}$ ). A typical performance curve is shown in Figure 7.

Table I. Temperature Data Format

Temperature	Digital Output DB9 . . . DB0
$-128^{\circ}\text{C}$	10 0000 0000
$-125^{\circ}\text{C}$	10 0000 1100
$-100^{\circ}\text{C}$	10 0111 0000
$-75^{\circ}\text{C}$	10 1101 0100
$-50^{\circ}\text{C}$	11 0011 1000
$-25^{\circ}\text{C}$	11 1001 1100
$-0.25^{\circ}\text{C}$	11 1111 1111
$0^{\circ}\text{C}$	00 0000 0000
$+0.25^{\circ}\text{C}$	00 0000 0001
$+10^{\circ}\text{C}$	00 0010 1000
$+25^{\circ}\text{C}$	00 0110 0100
$+50^{\circ}\text{C}$	00 1100 1000
$+75^{\circ}\text{C}$	01 0010 1100
$+100^{\circ}\text{C}$	01 1001 0000
$+125^{\circ}\text{C}$	01 1111 0100
$+127^{\circ}\text{C}$	01 1111 1100

### SERIAL INTERFACE

The serial interface on the AD7814 consists of four wires  $\overline{\text{CS}}$ , SCLK, DIN, and DOUT. The interface can be operated in 3-wire mode with DIN tied to Ground, in which case the interface has read-only capability, with data being read from the data register via the DOUT line. The DIN line is used to write the part into standby mode, if required. The  $\overline{\text{CS}}$  line is used to select the device when more than one device is connected to the serial clock and data lines.

The part operates in a slave mode and requires an externally applied serial clock to the SCLK input to access data from the data register. The serial interface on the AD7814 is designed to allow the part to be interfaced to systems that provide a serial clock that is synchronized to the serial data, such as the 80C51, 87C51, 68HC11, 68HC05, and PIC16Cxx microcontrollers, as well as DSP processors.

A read operation from the AD7814 accesses data from the temperature value register, while a write operation to the part writes data to the control register.

# AD7814

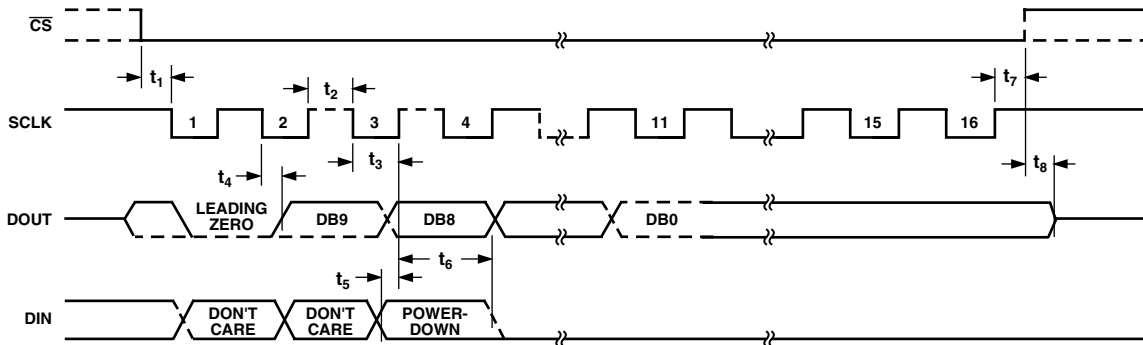

Figure 2. Serial Interface Timing Diagram

## Read Operation

Figure 2 shows the timing diagram for a serial read from the AD7814. The  $\overline{CS}$  line enables the SCLK input. Ten bits of data and a leading zero are transferred during a read operation. Read operations occur during streams of 16 clock pulses. The serial data is accessed in a number of bytes if 10 bits of data are being read. At the end of the read operation, the DOUT line remains in the state of the last bit of data clocked out of the AD7814 until  $\overline{CS}$  returns high, at which time the DOUT line goes into three-state.

## Write Operation

Figure 2 also shows the timing diagram for a serial write to the AD7814. The write operation takes place at the same time as the read operation. Data is clocked into the control register on the part on the rising edge of SCLK. Only the third bit in the data stream provides a user-controlled function. This third bit is the power-down bit which, when set to a 1, puts the AD7814 into shutdown mode. The first 2 bits of the data stream are “don’t cares” while all other bits in the data stream, other than the power-down bit, should be 0 to ensure correct operation of the AD7814. Data is loaded to the control register on the fifteenth falling SCLK edge and the data takes effect at this time (i.e., if the part is programmed to go into shutdown, it does so at this point). If the  $\overline{CS}$  is brought high before this fifteenth SCLK edge, the control register will not be loaded and the power-down status of the part will not change.

## MICROPROCESSOR INTERFACING

The AD7814’s serial interface allows for easy interface to most microcomputers and microprocessors. Figures 3 through 6 show some typical interface circuits.

The serial interface on the AD7814 consists of four wires:  $\overline{CS}$ , DIN, DOUT, and SCLK. All interface circuits shown utilize all four interface lines. However, it is possible to operate the interface with three wires. If the application does not require the power-down facility offered by the AD7814, the DIN line can be tied permanently low. Thus, the interface can be operated from just three wires: SCLK,  $\overline{CS}$ , and DOUT.

The serial data transfer to and from the AD7814 requires a 16-bit read operation. Many 8-bit microcontrollers have 8-bit serial ports and this 16-bit data transfer is handled as two 8-bit transfers. Other microcontrollers and DSP processors transfer 16 bits of data in a serial data operation.

## AD7814 to MC68HC11 Interface

Figure 3 shows an interface between the AD7814 and the MC68HC11 microcontroller. The MC68HC11 is configured in the master mode with its CPOL bit set to a logic one and its CPHA bit set to a logic one. When the MC68HC11 is configured like this, its SCLK line idles high between data transfers. Data is transferred to and from the AD7814 in two 8-bit serial data operations. The diagram shows the full (4-wire) interface. PC1 of the MC68HC11 is configured as an output and used to drive the  $\overline{CS}$  input.

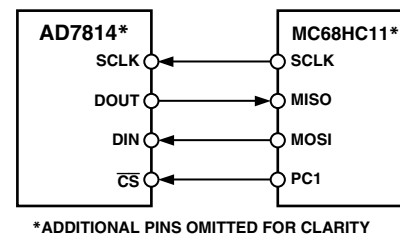

Figure 3. AD7814 to MC68HC11 Interface

## AD7814 to 8051 Interface

An interface circuit between the AD7814 and the 8051 microcontroller is shown in Figure 4. The 8xC51 is configured in its Mode 0 serial interface mode. The serial clock line of the 8xC51 (on P3.1) idles high between data transfers. Data is transferred to and from the AD7814 in two 8-bit serial data operations. The AD7814 outputs the MSB of its data stream as the first valid bit while the 8xC51 expects the LSB first. Thus, the data read into the serial buffer needs to be rearranged before the correct data word from the AD7814 is available in the accumulator.

In the example shown, the AD7814 is connected to the serial port of the 8051. Because the serial interface of the 8xC51 contains only one data line, the DIN line of the AD7814 is tied low in the interface example given in Figure 4.

For applications that require the use of the power-down feature of the AD7814, the serial interface should be implemented using data port lines on the 8051. This allows a full-duplex serial interface to be implemented. The method involves ‘bit-banging’ a port line to generate a serial clock while using two other port lines to shift data in and out with the fourth port line connecting to  $\overline{CS}$ . Port lines 1.0 through 1.3 (with P1.1 configured as an input) can be used to connect to SCLK, DOUT, DIN, and  $\overline{CS}$ , respectively, to implement this scheme.

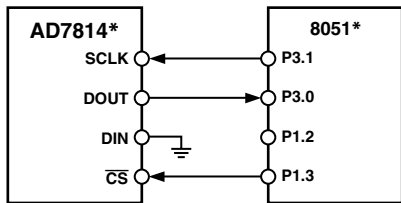

\*ADDITIONAL PINS OMITTED FOR CLARITY

Figure 4. AD7814 to 8051 Interface

### AD7814 to PIC16C6x/7x Interface

Figure 5 shows an interface circuit between the AD7814 and the PIC16C6x/7x microcontroller. The PIC16C6x/7x synchronous serial port (SSP) is configured as an SPI master with the clock polarity bit set to a logic one. In this mode, the serial clock line of the PIC16C6x/7x idles high between data transfers. Data is transferred to and from the AD7814 in two 8-bit serial data operations. In the example shown, port line RA1 is being used to generate the  $\overline{CS}$  for the AD7814.

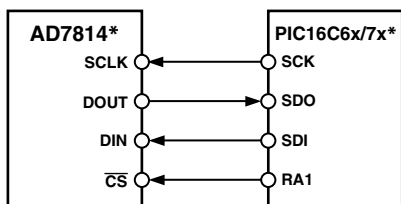

\*ADDITIONAL PINS OMITTED FOR CLARITY

Figure 5. AD7814 to PIC16C6x/7x Interface

### AD7814 to ADSP-21xx Interface

Figure 6 shows an interface between the AD7814 and the ADSP-21xx DSP processor. To ensure correct operation of the interface, the SPORT control register should be set up as follows:

- TFSW = RFSW = 1, Alternate Framing
- INVRFS = INVTFS = 1, Active Low Framing Signal
- DTYPE = 00, Right Justify Data
- SLEN = 1111, 16-Bit Data Words
- ISCLK = 1, Internal Serial Clock
- TFSR = RFS = 1, Frame Every Word
- IRFS = 0, RFS Configured As Input
- ITFS = 1, TFS Configured As Output

The interface requires an inverter between the SCLK line of the ADSP-21xx and the SCLK input of the AD7814. The ADSP-21xx has the TFS and RFS of the SPORT tied together with TFS set as an output and RFS set as an input. The DSP operates in alternate framing mode and the SPORT control register is set up as described earlier.

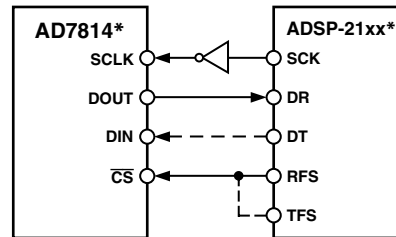

\*ADDITIONAL PINS OMITTED FOR CLARITY

Figure 6. AD7814 to ADSP-21xx Interface

### MOUNTING THE AD7814

The AD7814 can be used for surface or air temperature sensing applications. If the device is cemented to a surface with thermally conductive adhesive, the die temperature will be within about 0.1°C of the surface temperature, thanks to the device's low power consumption. Care should be taken to insulate the back and leads of the device from the air, if the ambient air temperature is different from the surface temperature being measured.

The ground pin provides the best thermal path to the die, so the temperature of the die will be close to that of the printed circuit ground track. Care should be taken to ensure that this is in good thermal contact with the surface being measured.

As with any IC, the AD7814 and its associated wiring and circuits must be kept free from moisture to prevent leakage and corrosion, particularly in cold conditions where condensation is more likely to occur. Water-resistant varnishes and conformal coatings can be used for protection. The small size of the AD7814 package allows it to be mounted inside sealed metal probes, which provide a safe environment for the device.

### SUPPLY DECOUPLING

The AD7814 should be decoupled with a 0.1 μF ceramic capacitor between  $V_{DD}$  and GND. This is particularly important if the AD7814 is mounted remotely from the power supply.

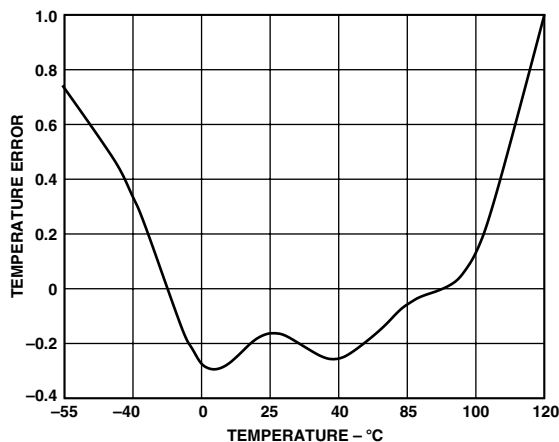
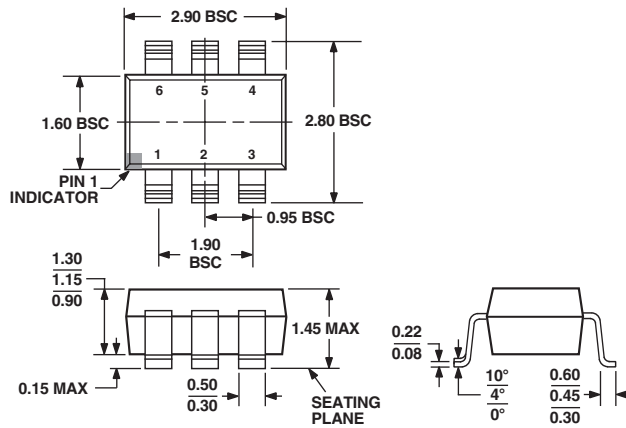

Figure 7. Typical Temperature Error

OUTLINE DIMENSIONS

6-Lead Small Outline Transistor Package [SOT-23]  
(RT-6)

Dimensions shown in millimeters



COMPLIANT TO JEDEC STANDARDS MO-178AB

8-Lead Mini Small Outline Package [MSOP]  
(RM-8)

Dimensions shown in millimeters

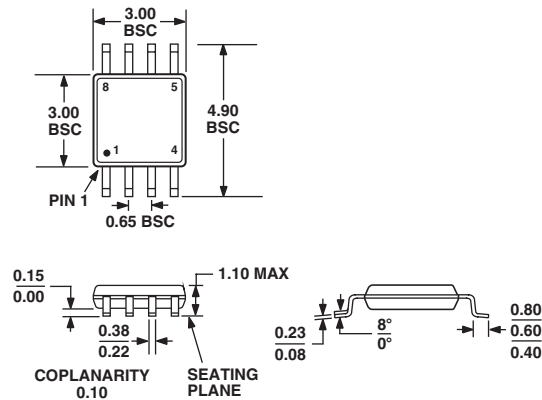

COMPLIANT TO JEDEC STANDARDS MO-187AA

Revision History

Location	Page
8/04—Data Sheet Changed from REV. D to REV. E.	
Changes to ORDERING GUIDE	3
Changes to CONVERTER DETAILS section	5
Changes to Read Operation section	6
Updated OUTLINE DIMENSIONS	8
5/02—Data Sheet Changed from REV. C to REV. D.	
Updates to SPECIFICATIONS	2

## Looking for pricing, stock, or lifecycle information?

Click below to explore more details on WIN SOURCE:

 [View AD7814ARM-REEL7 on WIN SOURCE](#)

 [Analog Devices Inc. Information](#)

## Optimize Your Supply Chain with WIN SOURCE Solutions

-  Global Sourcing Solution
-  Obsolete Management
-  Cost Control Management
-  Shortage Management
-  Alternative Solution
-  Excess Inventory Management