



# THE DATASHEET OF SN65MLVD3DRBTG4





## SINGLE M-LVDS RECEIVERS

### FEATURES

- Low-Voltage Differential 30-Ω to 55-Ω Line Receivers for Signaling Rates<sup>(1)</sup> up to 250Mbps; Clock Frequencies up to 125MHz
- SN65MLVD2 Type-1 Receiver Incorporates 25 mV of Input Threshold Hysteresis
- SN65MLVD3 Type-2 Receiver Provides 100 mV Offset Threshold to Detect Open-Circuit and Idle-Bus Conditions
- Wide Receiver Input Common-Mode Voltage Range, -1 V to 3.4 V, Allows 2 V of Ground Noise
- Improved  $V_{IT}$  (35 mV)
- Meets or Exceeds the M-LVDS Standard TIA/EIA-899 for Multipoint Topology
- High Input Impedance with Low Supply Voltage
- Bus-Pin HBM ESD Protection Exceeds 9 kV
- Packaged in 8-Pin SON (DRB) 70% Smaller Than 8-Pin SOIC

<sup>(1)</sup> The signaling rate of a line is the number of voltage transitions that are made per second, expressed in the units bps (bits per second).

### APPLICATIONS

- Parallel Multipoint Data and Clock Transmission via Backplanes and Cables
- Cellular Base Stations
- Central Office Switches
- Network Switches and Routers

### PACKAGE AND PIN-OUT

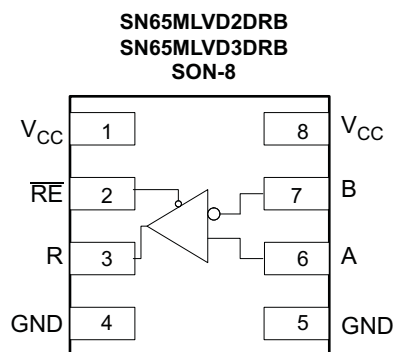

### DESCRIPTION

The SN65MLVD2 and SN65MLVD3 are single-channel M-LVDS receivers. These devices are designed in full compliance with the TIA/EIA-899 (M-LVDS) standard, which are optimized to operate at signaling rates up to 250 Mbps. Each receiver channel is controlled by a receive enable ( $\overline{RE}$ ). When  $\overline{RE}$  = low, the corresponding channel is enabled; when  $\overline{RE}$  = high, the corresponding channel is disabled.

The M-LVDS standard defines two types of receivers, designated as Type-1 and Type-2. Type-1 receivers (SN65MLVD2) have thresholds centered about zero with 25 mV of hysteresis to prevent output oscillations with loss of input; Type-2 receivers (SN65MLVD3) implement a failsafe by using an offset threshold. Receiver outputs are slew rate controlled to reduce EMI and crosstalk effects associated with large current surges.

The devices are characterized for operation from -40°C to 85°C.



Please be aware that an important notice concerning availability, standard warranty, and use in critical applications of Texas Instruments semiconductor products and disclaimers thereto appears at the end of this data sheet.

TYPICAL APPLICATION

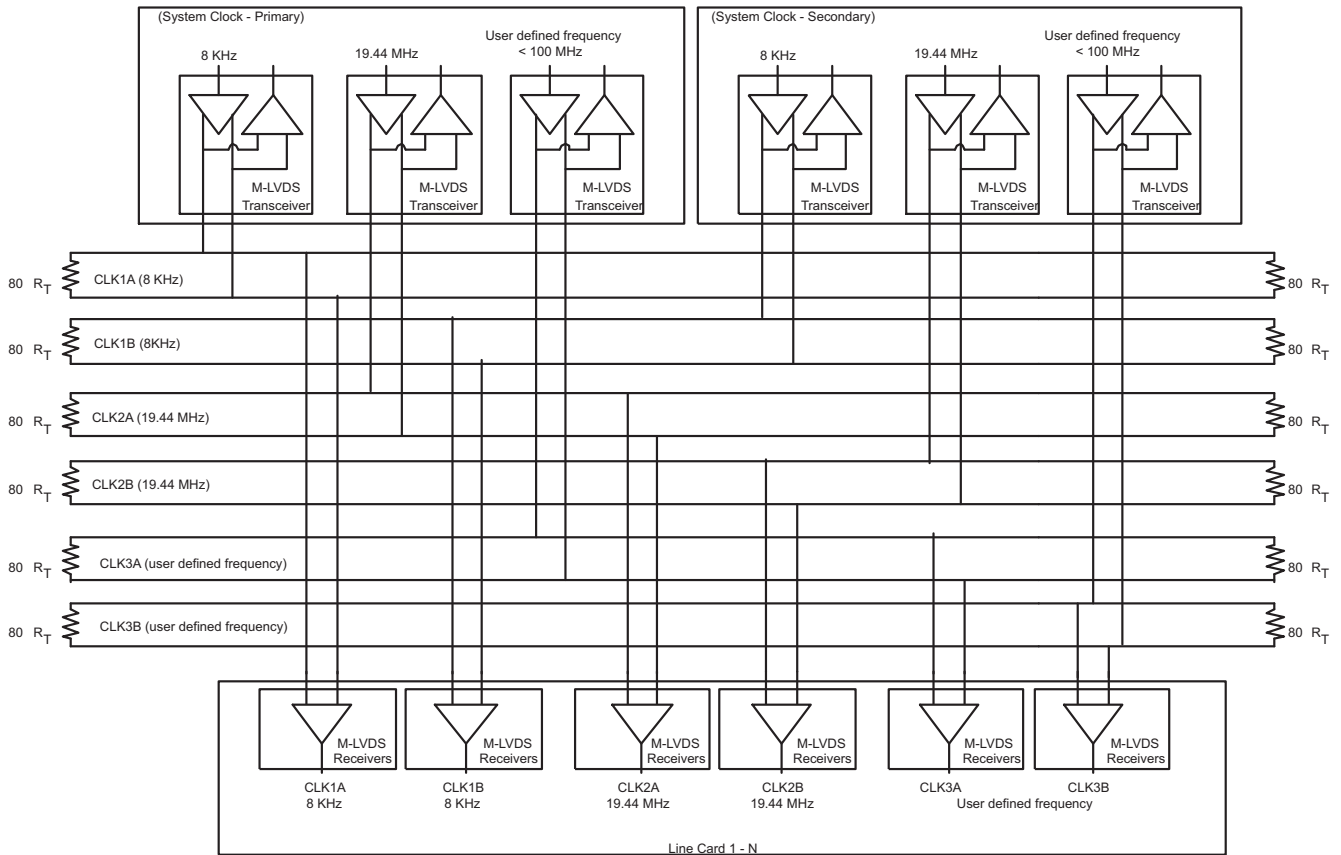

AdvancedTCA Backplane - Synchronized System Clock



These devices have limited built-in ESD protection. The leads should be shorted together or the device placed in conductive foam during storage or handling to prevent electrostatic damage to the MOS gates.

### ORDERING INFORMATION<sup>(1)</sup>

PART NUMBER	FUNCTION	PART MARKING	PACKAGE / CARRIER
SN65MLVD2DRBT	M-LVDS Type 1 Receiver	MF2	8-Pin SON / Small Tape and Reel
SN65MLVD2DRBR	M-LVDS Type 1 Receiver	MF2	8-Pin SON / Tape and Reel
SN65MLVD3DRBT	M-LVDS Type 2 Receiver	MF3	8-Pin SON / Small Tape and Reel
SN65MLVD3DRBR	M-LVDS Type 2 Receiver	MF3	8-Pin SON / Tape and Reel

(1) For the most current package and ordering information, see the Package Option Addendum at the end of this document, or see the TI website at [www.ti.com](http://www.ti.com).

### ABSOLUTE MAXIMUM RATINGS

over operating free-air temperature range (unless otherwise noted) <sup>(1)</sup>

		VALUE	UNIT	
$V_{CC}$	Supply voltage range <sup>(2)</sup>	–0.5 to 4	V	
Input voltage range	RE	–0.5 to 4	V	
	A or B	–1.8 to 4	V	
Output voltage range	R	–0.3 to 4	V	
Electrostatic discharge	Human-body model <sup>(3)</sup>	All other pins	±7	kV
		A, B	±9	
	Machine model <sup>(4)</sup>	All pins	±200	V
	Field-induced-charged-device model <sup>(5)</sup>	All pins	±2	kV
Continuous power dissipation		See Dissipation Rating Table		

- (1) Stresses beyond those listed under *absolute maximum ratings* may cause permanent damage to the device. These are stress ratings only, and functional operation of the device at these or any other conditions beyond those indicated under *recommended operating conditions* is not implied. Exposure to absolute-maximum-rated conditions for extended periods may affect device reliability.
- (2) All voltage values, except differential I/O bus voltages, are with respect to network ground terminal.
- (3) Tested in accordance with JEDEC Standard 22, Test Method A114-A. Bus pin stressed with respect to a common connection of GND and  $V_{CC}$ .
- (4) Tested in accordance with JEDEC Standard 22 Test Method A115-A.
- (5) Tested in accordance with EIA-JEDEC JESD22-C101C.

### PACKAGE DISSIPATION RATINGS<sup>(1)</sup>

PACKAGE	PCB TYPE	$T_A \leq 25^\circ\text{C}$ POWER RATING	DERATING FACTOR <sup>(2)</sup> ABOVE $T_A = 25^\circ\text{C}$	$T_A = 85^\circ\text{C}$ POWER RATING
8-SON DRB	Low-K	280 mW	2.80 mW/°C	112 mW
	High-K	662 mW	6.62 mW/°C	264 mW

- (1) The thermal dissipations are in the consideration of soldering down the powerPAD without via on each type of boards.
- (2) This is the inverse of the junction-to-ambient thermal resistance when board-mounted and with no air flow.

### THERMAL CHARACTERISTICS

PARAMETER	TEST CONDITIONS	MIN	TYP	MAX	UNIT
$\theta_{JB}$ Junction-to-board thermal resistance			89		°C/W
$\theta_{JC}$ Junction-to-case thermal resistance			98		°C/W
$P_D$ Device power dissipation	RE at 0 V, $C_L = 15$ pF, $V_{ID} = 400$ mV, 125 MHz			90	mW

## RECOMMENDED OPERATING CONDITIONS

over operating free-air temperature range (unless otherwise noted)

		MIN	NOM	MAX	UNIT
$V_{CC}$	Supply voltage	3	3.3	3.6	V
$V_{IH}$	High-level input voltage	2		$V_{CC}$	V
$V_{IL}$	Low-level input voltage	GND		0.8	V
$V_A$ or $V_B$	Voltage at any bus terminal	-1.4		3.8	V
$ V_{ID} $	Magnitude of differential input voltage	0.035		$V_{CC}$	V
$V_{IC}$	Differential common-mode input voltage	-1		3.4	V
$R_L$	Differential load resistance	30	50		$\Omega$
$1/t_{UI}$	Signaling rate			250	Mbps
$T_A$	Operating free-air temperature	-40		85	$^{\circ}\text{C}$

## DEVICE ELECTRICAL CHARACTERISTICS

over recommended operating conditions (unless otherwise noted)

PARAMETER	TEST CONDITIONS	MIN	TYP <sup>(1)</sup>	MAX	UNIT
$I_{CC}$	Supply current			25	mA

(1) All typical values are at 25°C and with a 3.3-V supply voltage.

## RECEIVER ELECTRICAL CHARACTERISTICS

over recommended operating conditions (unless otherwise noted)

PARAMETER	TEST CONDITIONS	MIN	TYP <sup>(1)</sup>	MAX	UNIT
$V_{IT+}$	Positive-going differential input voltage threshold	Type 1		35	mV
		Type 2		135	
$V_{IT-}$	Negative-going differential input voltage threshold	Type 1		-35	mV
		Type 2		65	
$V_{HYS}$	Differential input voltage hysteresis ( $V_{IT+} - V_{IT-}$ )	Type 1		25	mV
		Type 2		0	
$V_{OH}$	High-level output voltage	$I_{OH} = -8$ mA	2.4		V
$V_{OL}$	Low-level output voltage	$I_{OL} = 8$ mA		0.4	V
$I_{IH}$	High-level input current	$V_{IH} = 2$ V to $V_{CC}$	-10		$\mu\text{A}$
$I_{IL}$	Low-level input current	$V_{IL} = \text{GND}$ to 0.8 V	-10		$\mu\text{A}$
$I_{OZ}$	High-impedance output current	$V_O = 0$ V or $V_{CC}$	-10	15	$\mu\text{A}$
$I_A$ or $I_B$	Receiver input current	One input ( $V_A$ or $V_B$ ) = -1.4 V or 3.8 V, Other input = 1.2 V	-20	20	$\mu\text{A}$
$I_{AB}$	Receiver differential input current ( $I_A - I_B$ )	$V_A = V_B = -1.4$ V or 3.8 V	-4	4	$\mu\text{A}$
$I_{A(OFF)}$ or $I_{B(OFF)}$	Receiver input current	One input ( $V_A$ or $V_B$ ) = -1.4 V or 3.8 V, Other input = 1.2 V, $V_{CC} = \text{GND}$ or 1.5 V	-20	20	$\mu\text{A}$
$I_{AB(OFF)}$	Receiver power-off differential input current ( $I_A - I_B$ )	$V_A = V_B = -1.4$ V or 3.8 V, $V_{CC} = \text{GND}$ or 1.5 V	-4	4	$\mu\text{A}$
$C_A$ or $C_B$	Input capacitance	$V_I = 0.4\sin(30E6\pi t) + 0.5\text{V}$ , <sup>(2)</sup> Other input at 1.2 V		3	pF
$C_{AB}$	Differential input capacitance	$V_{AB} = 0.4\sin(30E6\pi t) + 0.5\text{V}$ <sup>(2)</sup>		2.5	pF
$C_{A/B}$	Input capacitance balance, ( $C_A/C_B$ )		0.99	1.01	

(1) All typical values are at 25°C and with a 3.3-V supply voltage.

(2) HP4194A impedance analyzer (or equivalent)

## RECEIVER SWITCHING CHARACTERISTICS

over recommended operating conditions (unless otherwise noted)

PARAMETER		TEST CONDITIONS	MIN	TYP <sup>(1)</sup>	MAX	UNIT	
t <sub>PLH</sub>	Propagation delay time, low-to-high-level output	C <sub>L</sub> = 15 pF, See <a href="#">Figure 2</a>	2		6	ns	
t <sub>PHL</sub>	Propagation delay time, high-to-low-level output		2		6	ns	
t <sub>r</sub>	Output signal rise time		1		2.3		
t <sub>f</sub>	Output signal fall time		1		2.3	ns	
t <sub>sk(p)</sub>	Pulse skew ( t <sub>PHL</sub> - t <sub>PLH</sub>  )		Type 1		90	210	ps
			Type 2		45	250	
t <sub>sk(pp)</sub>	Part-to-part skew				1	ns	
t <sub>jit(per)</sub>	Period jitter, rms (1 standard deviation) <sup>(2)</sup>		125 MHz clock input			10	ps
t <sub>jit(c-c)</sub>	Cycle-to-cycle jitter, rms <sup>(3)</sup>		125 MHz clock input <sup>(4)</sup>			8	ps
t <sub>jit(det)</sub>	Deterministic jitter <sup>(2)</sup>		Type 1	250 Mbps 2 <sup>15</sup> -1 PRBS input <sup>(5)</sup>		500	ps
		Type 2			450	ps	
t <sub>jit(ran)</sub>	Random jitter <sup>(2)</sup>	Type 1	250 Mbps 2 <sup>15</sup> -1 PRBS input <sup>(5)</sup>		8	ps	
		Type 2			8	ps	
t <sub>PZH</sub>	Enable time, high-impedance-to-high-level output	C <sub>L</sub> = 15 pF, See <a href="#">Figure 3</a>			15	ns	
t <sub>PZL</sub>	Enable time, high-impedance-to-low-level output	C <sub>L</sub> = 15 pF, See <a href="#">Figure 3</a>			15	ns	
t <sub>PHZ</sub>	Disable time, high-level-to-high-impedance output	C <sub>L</sub> = 15 pF, See <a href="#">Figure 3</a>			10	ns	
t <sub>PLZ</sub>	Disable time, low-level-to-high-impedance output	C <sub>L</sub> = 15 pF, See <a href="#">Figure 3</a>			10	ns	

- (1) All typical values are at 25°C and with a 3.3-V supply voltage.
- (2) Jitter measured by triggering off of the input source to track out the associated input jitter.
- (3) Stimulus jitter has been subtracted from the numbers.
- (4) Measured over 75K samples
- (5) Measured over BER = 10<sup>-6</sup>.

## TERMINAL FUNCTIONS

TERMINAL		I/O	DESCRIPTION
NAME	NO.		
A	6	I	M-LVDS Non-inverting input
B	7	I	M-LVDS Inverting input
R	3	O	Data output from receivers
$\overline{RE}$	2	I	Receiver enable, active low, enables all receivers
GND	4, 5		Circuit ground
V <sub>CC</sub>	1, 8		Supply voltage

## DEVICE FUNCTION TABLES

TYPE-1 RECEIVER (SN65MLVD2)			TYPE-2 RECEIVER (SN65MLVD3)		
INPUTS <sup>(1)</sup>		OUTPUT <sup>(1)</sup>	INPUTS <sup>(1)</sup>		OUTPUT <sup>(1)</sup>
V <sub>ID</sub> = V <sub>A</sub> - V <sub>B</sub>	$\overline{RE}$	R	V <sub>ID</sub> = V <sub>A</sub> - V <sub>B</sub>	$\overline{RE}$	R
V <sub>ID</sub> ≥ 35 mV	L	H	V <sub>ID</sub> ≥ 135 mV	L	H
-35 mV ≤ V <sub>ID</sub> ≤ 35 mV	L	?	65 mV ≤ V <sub>ID</sub> ≤ 135 mV	L	?
V <sub>ID</sub> ≤ -35 mV	L	L	V <sub>ID</sub> ≤ 65 mV	L	L
X	H	Z	X	H	Z
X	Open	Z	X	Open	Z
Open Circuit	L	?	Open Circuit	L	L

- (1) H=high level, L=low level, Z=high impedance, X=Don't care, ?=indeterminate

EQUIVALENT INPUT AND OUTPUT SCHEMATIC DIAGRAMS

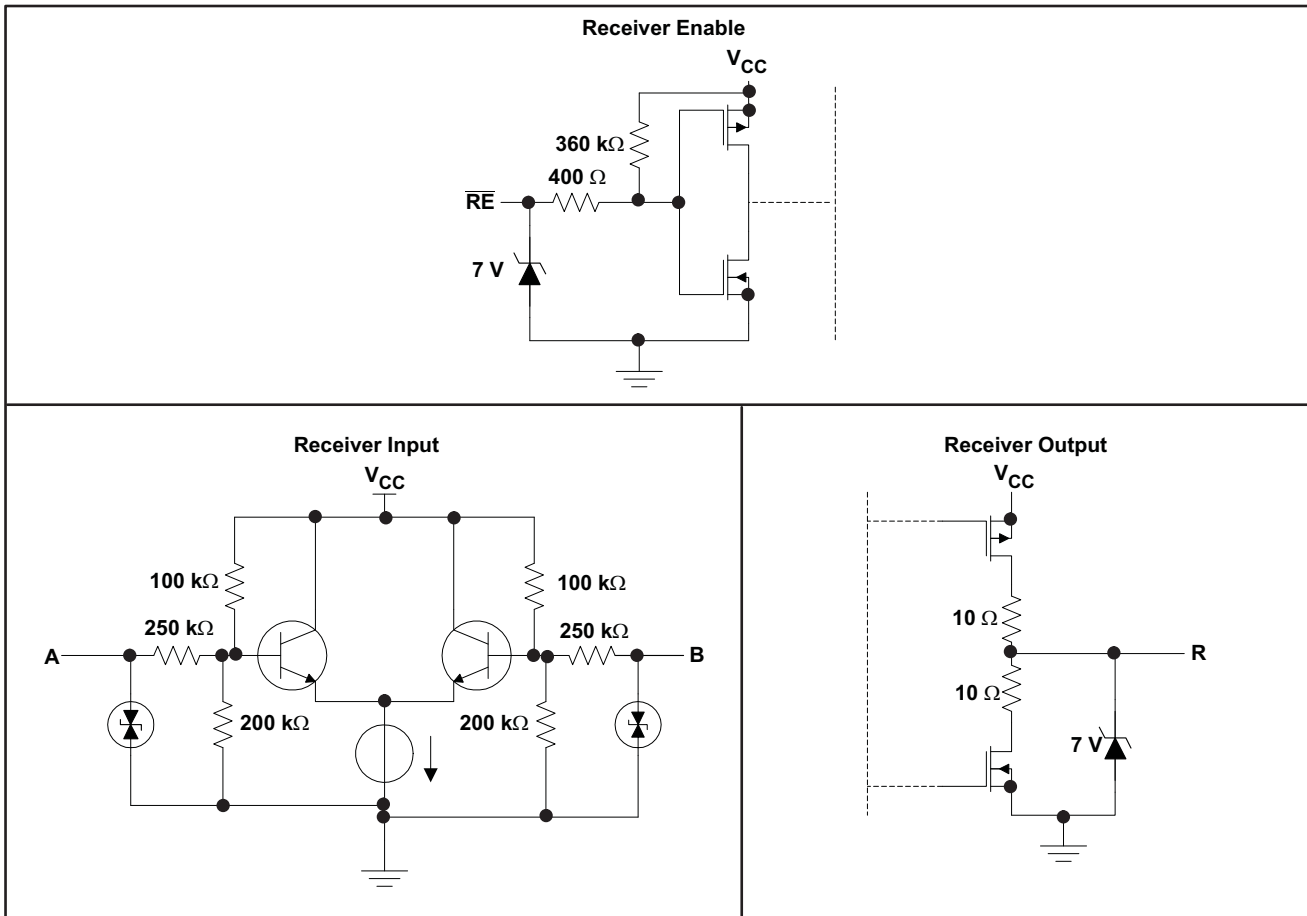

## PARAMETER MEASUREMENT INFORMATION

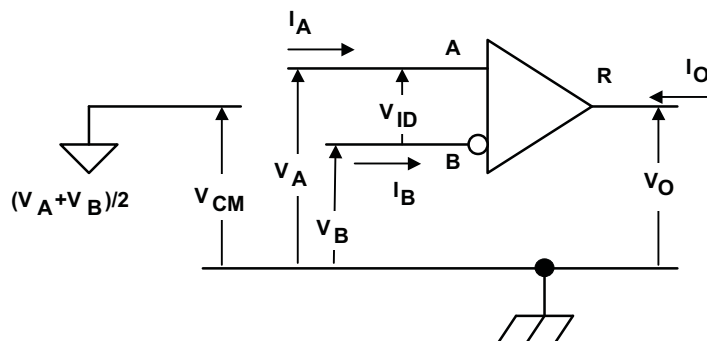

Figure 1. Receiver Voltage and Current Definitions

Table 1. Type-1 Receiver Input Threshold Test Voltages

APPLIED VOLTAGES		RESULTING DIFFERENTIAL INPUT VOLTAGE	RESULTING COMMON-MODE INPUT VOLTAGE	RECEIVER OUTPUT <sup>(1)</sup>
$V_{IA}$	$V_{IB}$	$V_{ID}$	$V_{IC}$	
2.400	0.000	2.400	1.200	H
0.000	2.400	-2.400	1.200	L
3.400	3.365	0.035	3.3825	H
3.365	3.400	-0.035	3.3825	L
-0.965	-1	0.035	-0.9825	H
-1	-0.965	-0.035	-0.9825	L

(1) H= high level, L = low level, output state assumes receiver is enabled ( $\overline{RE} = L$ )

Table 2. Type-2 Receiver Input Threshold Test Voltages

APPLIED VOLTAGES		RESULTING DIFFERENTIAL INPUT VOLTAGE	RESULTING COMMON-MODE INPUT VOLTAGE	RECEIVER OUTPUT <sup>(1)</sup>
$V_{IA}$	$V_{IB}$	$V_{ID}$	$V_{IC}$	
2.400	0.000	2.400	1.200	H
0.000	2.400	-2.400	1.200	L
3.400	3.265	0.135	3.3325	H
3.4000	3.335	0.065	3.3675	L
-0.865	-1	0.135	-0.9325	H
-0.935	-1	0.065	-0.9675	L

(1) H= high level, L = low level, output state assumes receiver is enabled ( $\overline{RE} = L$ )

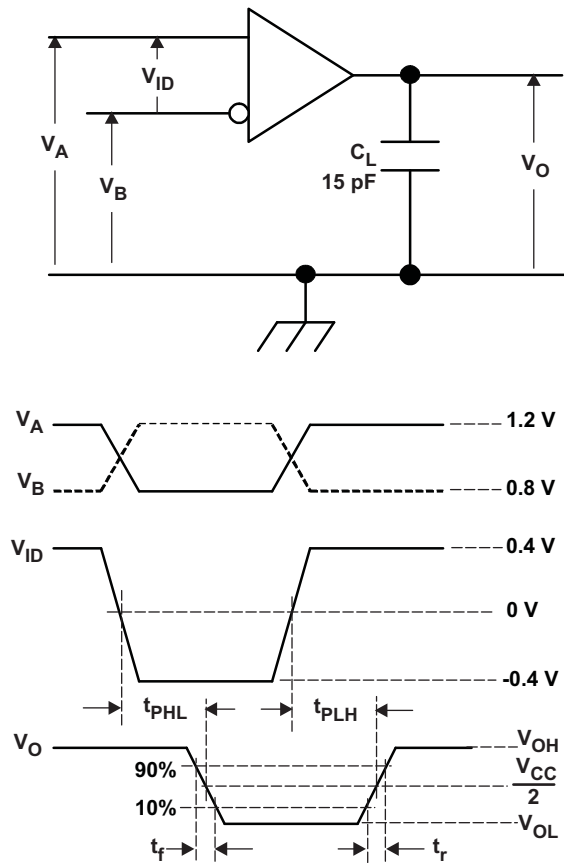

- A. All input pulses are supplied by a generator having the following characteristics:  $t_r$  or  $t_f \leq 1 \text{ ns}$ , Frequency = 1 MHz, duty cycle =  $50 \pm 5\%$ .  $C_L$  is a combination of a 20%-tolerance, low-loss ceramic, surface-mount capacitor and fixture capacitance within 2 cm of the D.U.T.
- B. The measurement is made on test equipment with a  $-3\text{dB}$  bandwidth of at least 1 GHz.

**Figure 2. Receiver Timing Test Circuit and Waveforms**

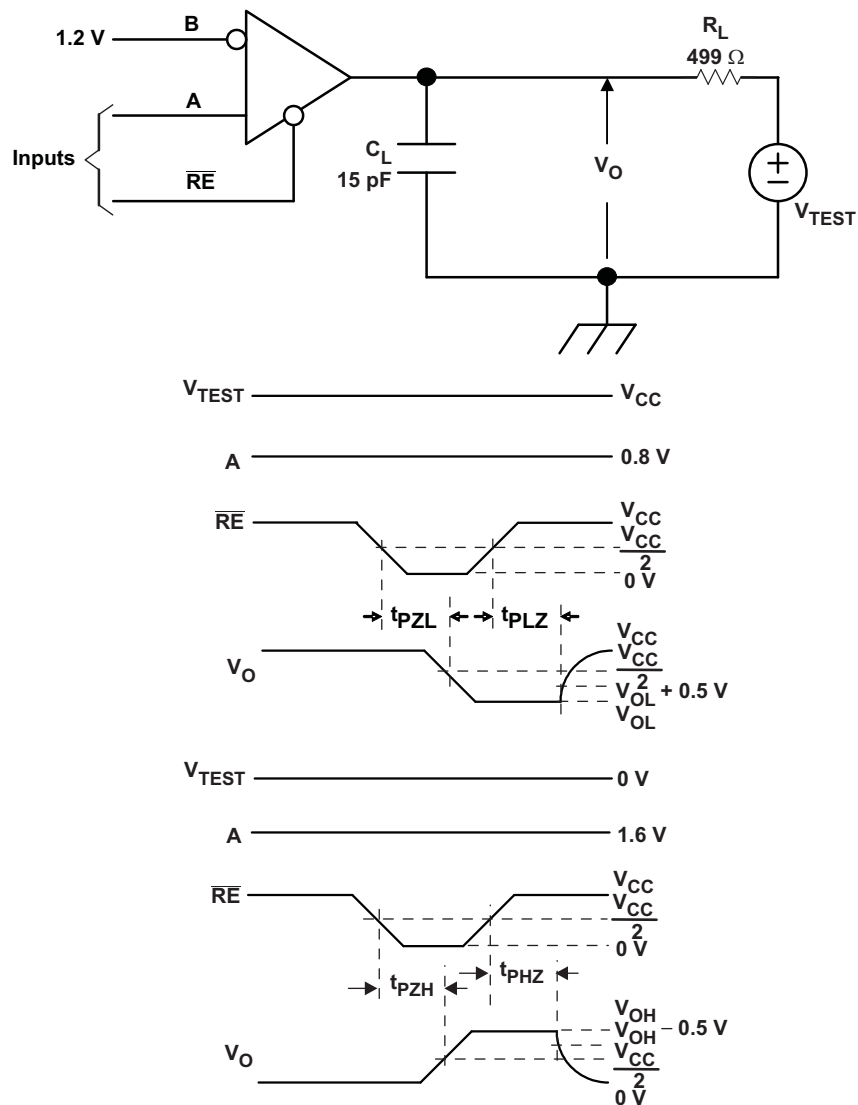

- All input pulses are supplied by a generator having the following characteristics:  $t_r$  or  $t_f \leq 1$  ns, frequency = 1 MHz, duty cycle =  $50 \pm 5\%$ .
- $R_L$  is 1% tolerance, metal film, surface mount, and located within 2 cm of the D.U.T
- $C_L$  is the instrumentation and fixture capacitance within 2 cm of the D.U.T. and  $\pm 20\%$ . The measurement is made on test equipment with a  $-3$ dB bandwidth of at least 1GHz.

**Figure 3. Receiver Enable/Disable Time Test Circuit and Waveforms**

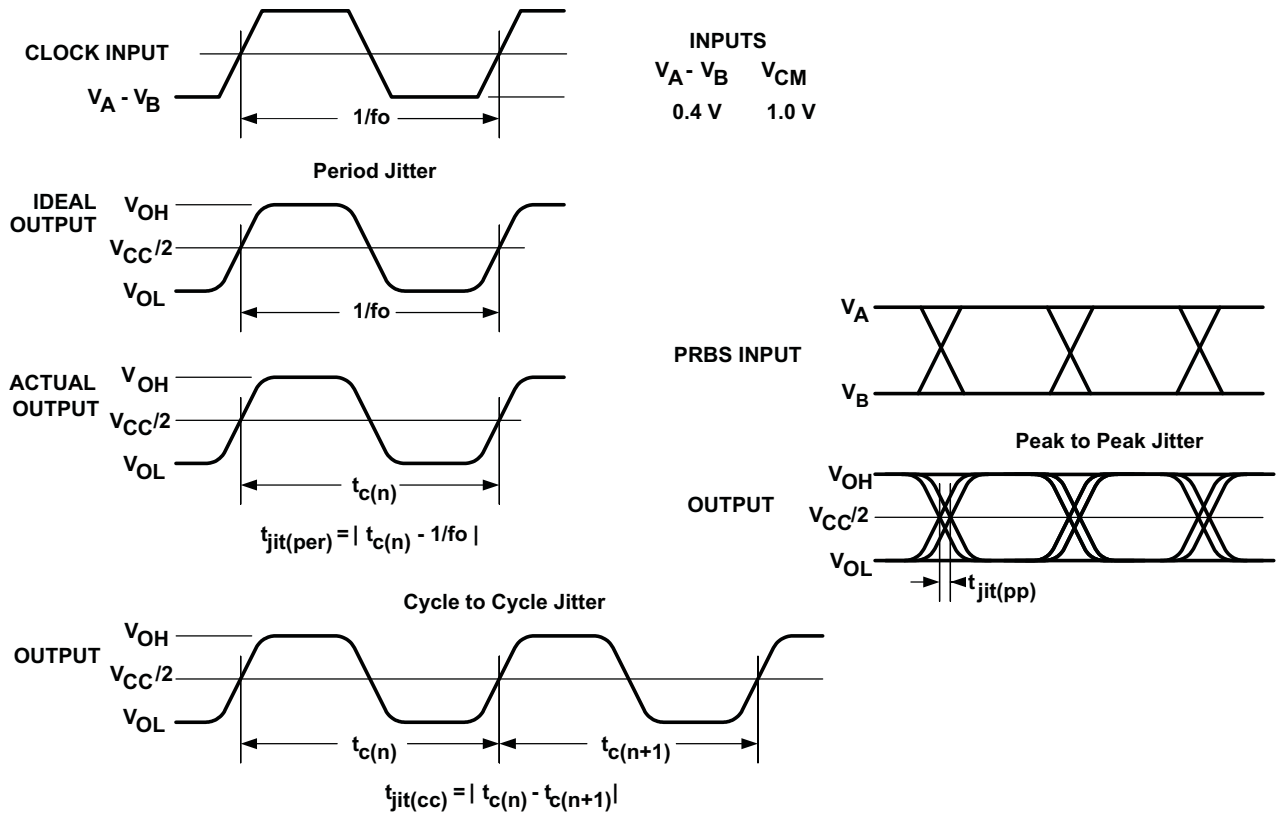

- A. All input pulses are supplied by the Agilent 81250 Parallel BERT Stimulus System with plug-in E4832A.
- B. The cycle-to-cycle jitter measurement is made on a TEK TDS6604 running TDSJIT3 application software
- C. Period jitter is measured using a 125-MHz  $50 \pm 1\%$  duty cycle clock input.
- D. Deterministic jitter and random jitter are measured using a 250-Mbps  $2^{15-1}$  PRBS input

**Figure 4. Receiver Jitter Measurement Waveforms**

**TYPICAL CHARACTERISTICS**

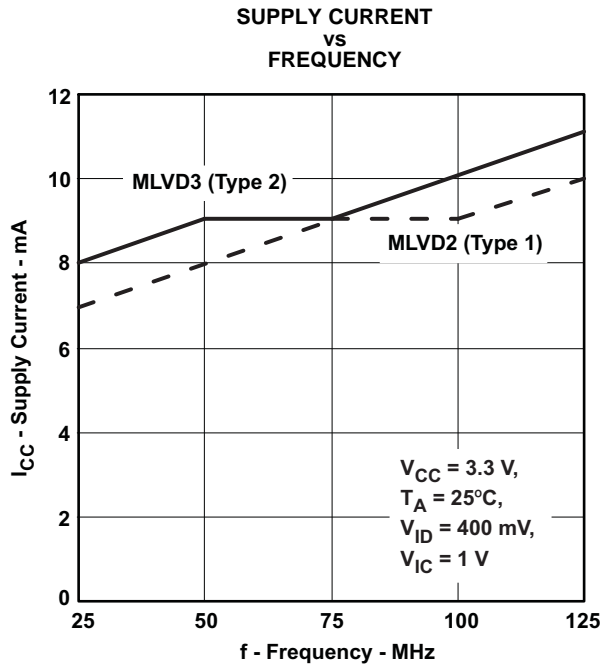

Figure 5.

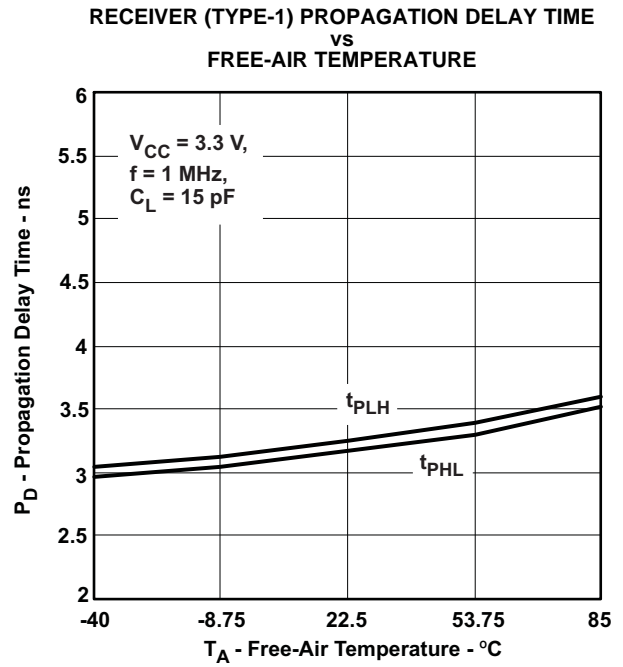

Figure 6.

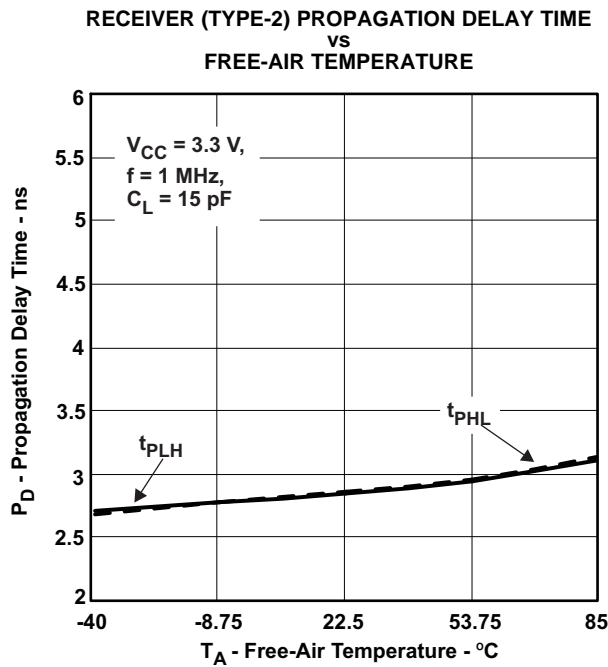

Figure 7.

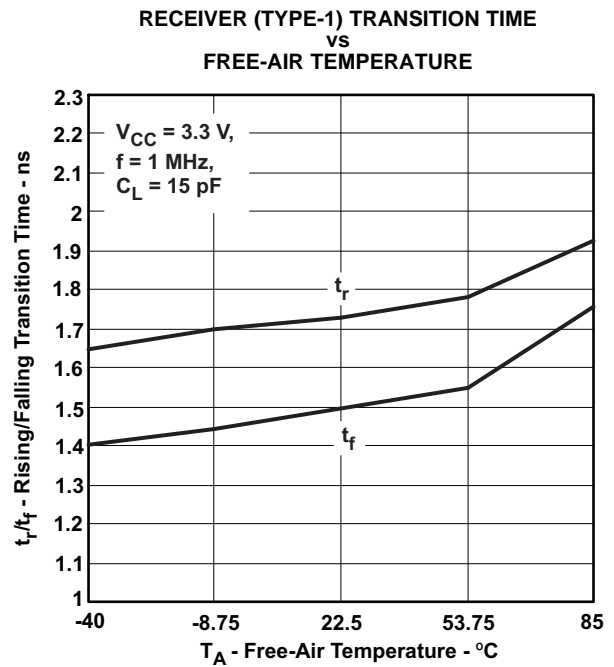

Figure 8.

TYPICAL CHARACTERISTICS (continued)

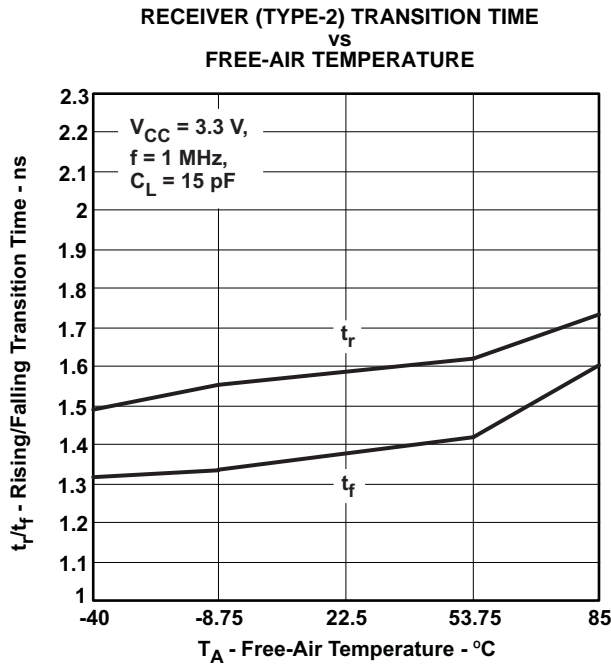

Figure 9.

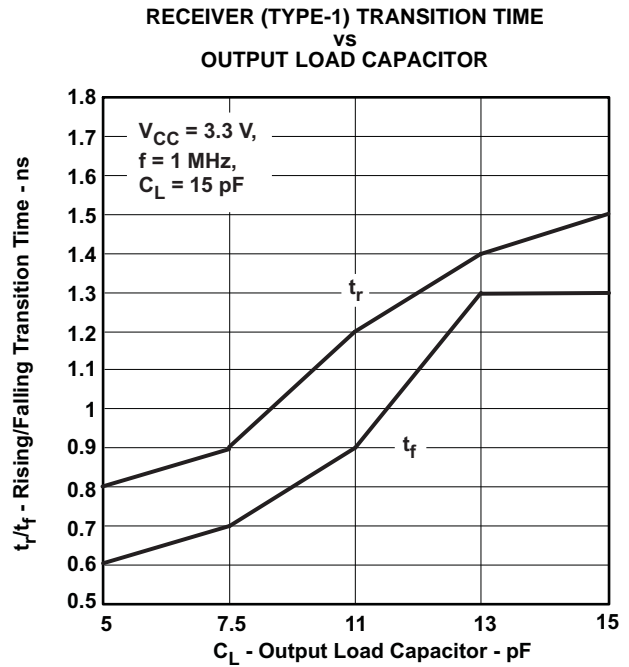

Figure 10.

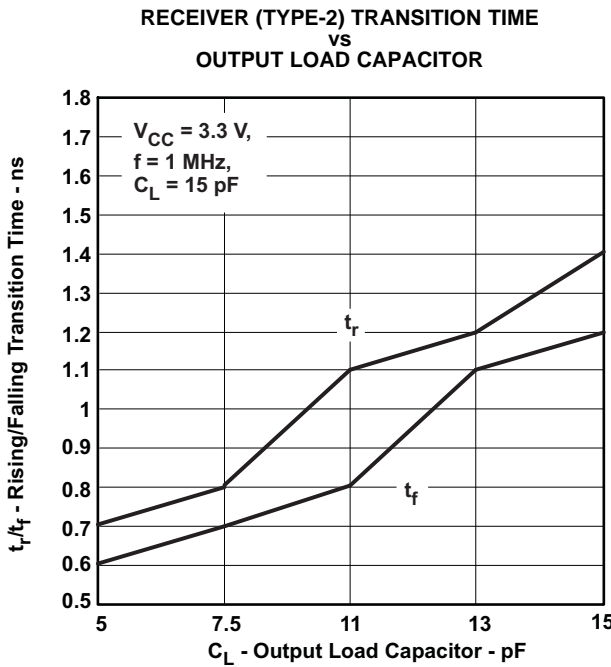

Figure 11.

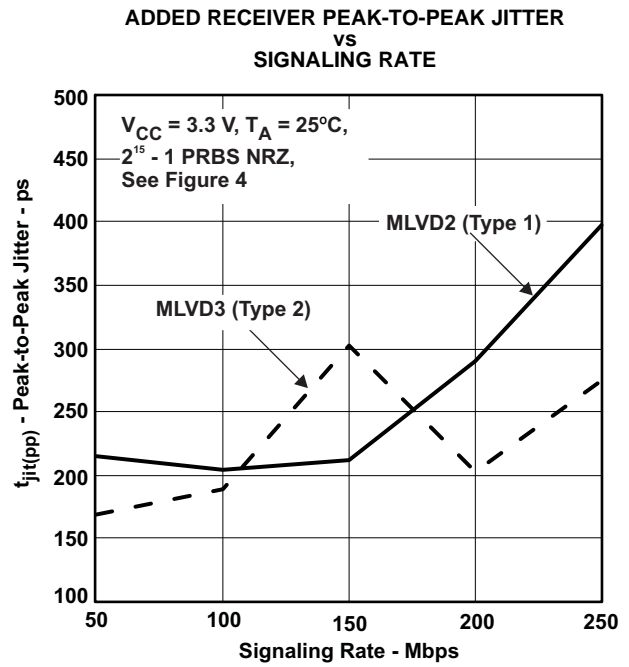

Figure 12.

**TYPICAL CHARACTERISTICS (continued)**

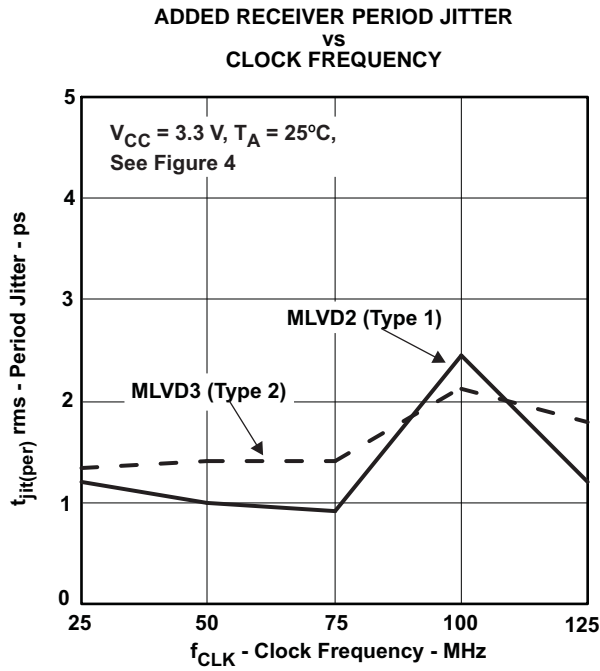

Figure 13.

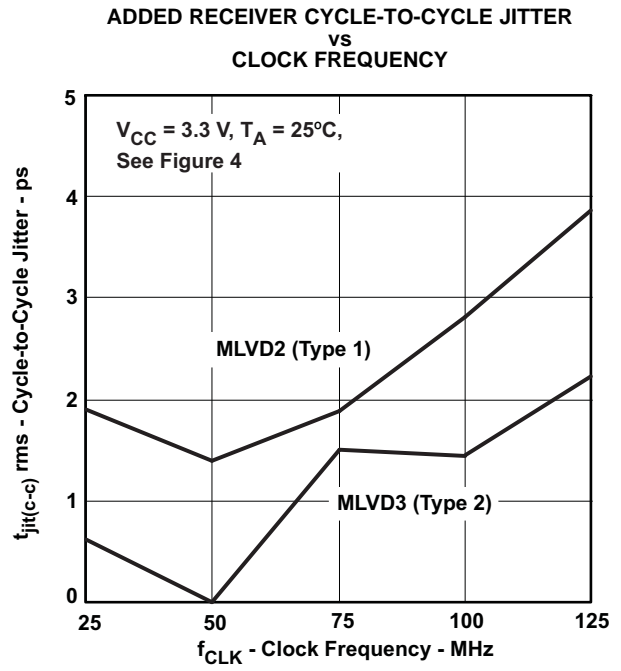

Figure 14.

**EYE PATTERNS**

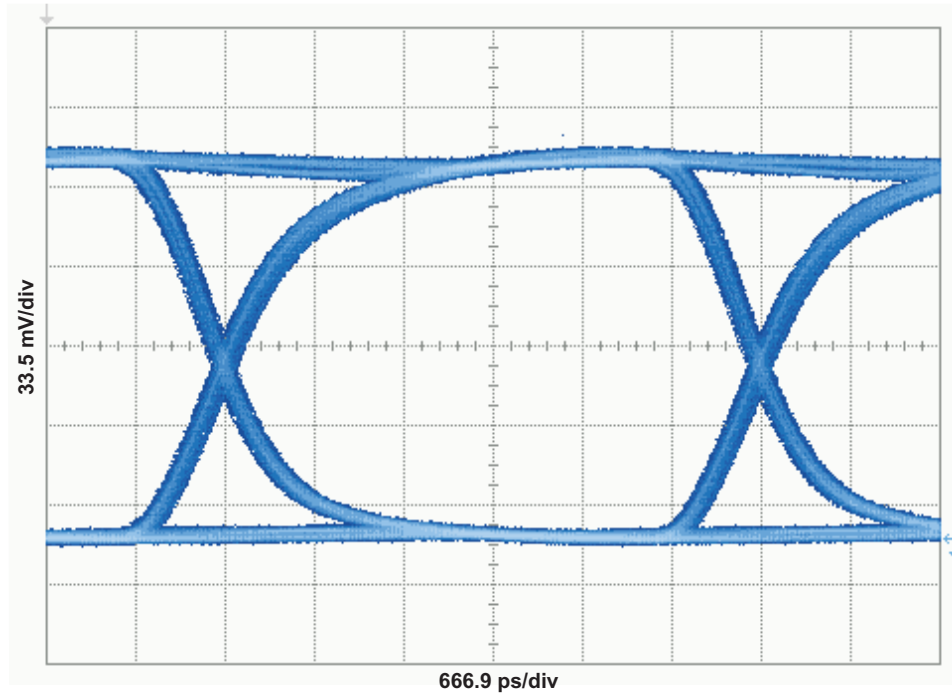

Figure 15. SN65MLVD2 Output ( $V_{CC} = 3.3\text{ V}$ ,  $C_L = 15\text{ pF}$ ) 250 Mbps  $2^{15}-1$  PRBS

TYPICAL CHARACTERISTICS (continued)

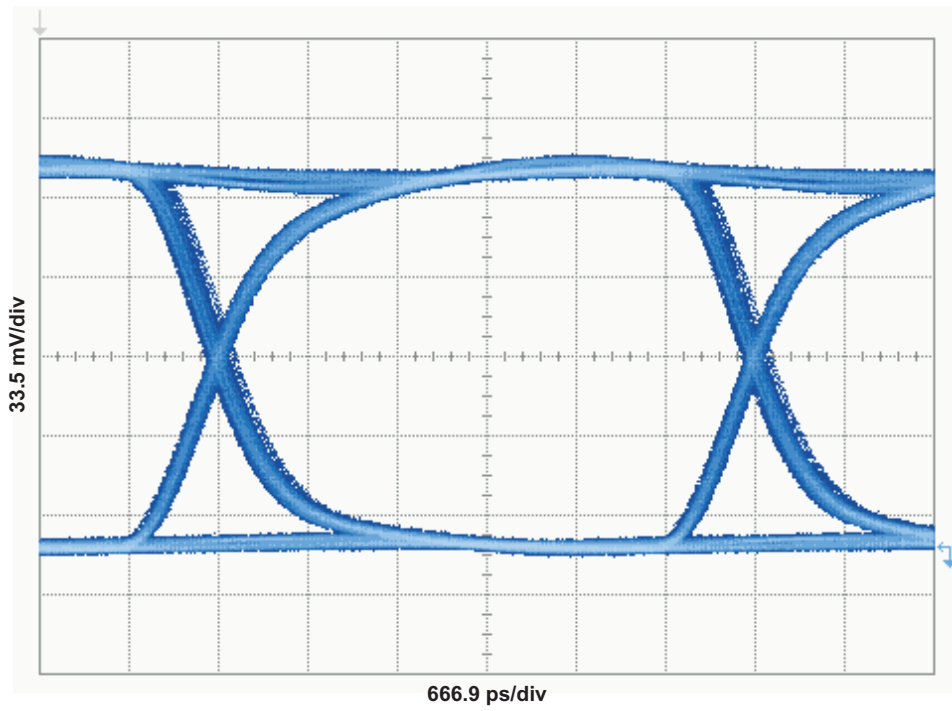

Figure 16. SN65MLVD3 Output ( $V_{CC} = 3.3\text{ V}$ ,  $C_L = 15\text{ pF}$ ) 250 Mbps  $2^{15}-1$  PRBS

**PACKAGING INFORMATION**

Orderable Device	Status (1)	Package Type	Package Drawing	Pins	Package Qty	Eco Plan (2)	Lead/Ball Finish (6)	MSL Peak Temp (3)	Op Temp (°C)	Device Marking (4/5)	Samples
SN65MLVD2DRBR	ACTIVE	SON	DRB	8	3000	Green (RoHS & no Sb/Br)	CU NIPDAU	Level-2-260C-1 YEAR	-40 to 85	MF2	<a href="#">Samples</a>
SN65MLVD2DRBT	ACTIVE	SON	DRB	8	250	Green (RoHS & no Sb/Br)	CU NIPDAU	Level-2-260C-1 YEAR	-40 to 85	MF2	<a href="#">Samples</a>
SN65MLVD3DRBR	ACTIVE	SON	DRB	8	3000	Green (RoHS & no Sb/Br)	CU NIPDAU	Level-2-260C-1 YEAR	-40 to 85	MF3	<a href="#">Samples</a>
SN65MLVD3DRBT	ACTIVE	SON	DRB	8	250	Green (RoHS & no Sb/Br)	CU NIPDAU	Level-2-260C-1 YEAR	-40 to 85	MF3	<a href="#">Samples</a>

(1) The marketing status values are defined as follows:

**ACTIVE:** Product device recommended for new designs.

**LIFEBUY:** TI has announced that the device will be discontinued, and a lifetime-buy period is in effect.

**NRND:** Not recommended for new designs. Device is in production to support existing customers, but TI does not recommend using this part in a new design.

**PREVIEW:** Device has been announced but is not in production. Samples may or may not be available.

**OBSELETE:** TI has discontinued the production of the device.

(2) **RoHS:** TI defines "RoHS" to mean semiconductor products that are compliant with the current EU RoHS requirements for all 10 RoHS substances, including the requirement that RoHS substance do not exceed 0.1% by weight in homogeneous materials. Where designed to be soldered at high temperatures, "RoHS" products are suitable for use in specified lead-free processes. TI may reference these types of products as "Pb-Free".

**RoHS Exempt:** TI defines "RoHS Exempt" to mean products that contain lead but are compliant with EU RoHS pursuant to a specific EU RoHS exemption.

**Green:** TI defines "Green" to mean the content of Chlorine (Cl) and Bromine (Br) based flame retardants meet JS709B low halogen requirements of <=1000ppm threshold. Antimony trioxide based flame retardants must also meet the <=1000ppm threshold requirement.

(3) **MSL, Peak Temp.** - The Moisture Sensitivity Level rating according to the JEDEC industry standard classifications, and peak solder temperature.

(4) There may be additional marking, which relates to the logo, the lot trace code information, or the environmental category on the device.

(5) Multiple Device Markings will be inside parentheses. Only one Device Marking contained in parentheses and separated by a "-" will appear on a device. If a line is indented then it is a continuation of the previous line and the two combined represent the entire Device Marking for that device.

(6) **Lead/Ball Finish** - Orderable Devices may have multiple material finish options. Finish options are separated by a vertical ruled line. Lead/Ball Finish values may wrap to two lines if the finish value exceeds the maximum column width.

**Important Information and Disclaimer:**The information provided on this page represents TI's knowledge and belief as of the date that it is provided. TI bases its knowledge and belief on information provided by third parties, and makes no representation or warranty as to the accuracy of such information. Efforts are underway to better integrate information from third parties. TI has taken and

continues to take reasonable steps to provide representative and accurate information but may not have conducted destructive testing or chemical analysis on incoming materials and chemicals. TI and TI suppliers consider certain information to be proprietary, and thus CAS numbers and other limited information may not be available for release.

In no event shall TI's liability arising out of such information exceed the total purchase price of the TI part(s) at issue in this document sold by TI to Customer on an annual basis.

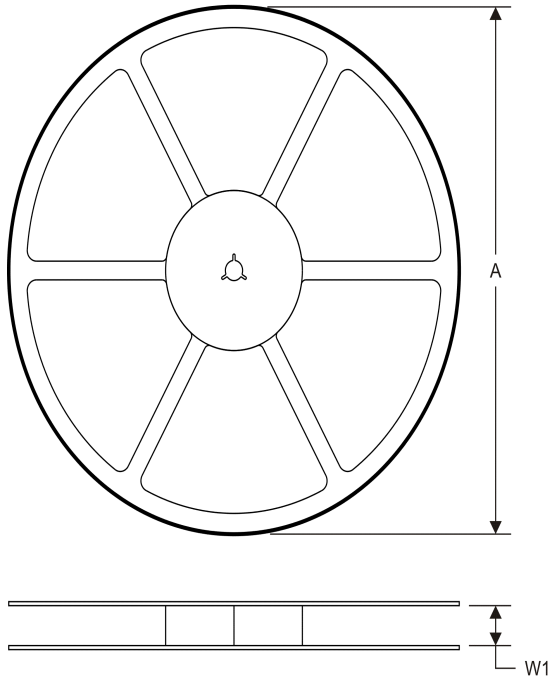
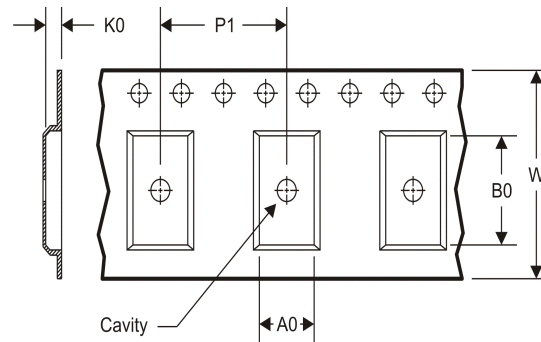
**TAPE AND REEL INFORMATION**
**REEL DIMENSIONS**

**TAPE DIMENSIONS**

A0	Dimension designed to accommodate the component width
B0	Dimension designed to accommodate the component length
K0	Dimension designed to accommodate the component thickness
W	Overall width of the carrier tape
P1	Pitch between successive cavity centers

**TAPE AND REEL INFORMATION**

\*All dimensions are nominal

Device	Package Type	Package Drawing	Pins	SPQ	Reel Diameter (mm)	Reel Width W1 (mm)	A0 (mm)	B0 (mm)	K0 (mm)	P1 (mm)	W (mm)	Pin1 Quadrant
SN65MLVD2DRBR	SON	DRB	8	3000	330.0	12.4	3.3	3.3	1.1	8.0	12.0	Q2
SN65MLVD2DRBT	SON	DRB	8	250	180.0	12.4	3.3	3.3	1.1	8.0	12.0	Q2
SN65MLVD3DRBR	SON	DRB	8	3000	330.0	12.4	3.3	3.3	1.1	8.0	12.0	Q2
SN65MLVD3DRBT	SON	DRB	8	250	180.0	12.4	3.3	3.3	1.1	8.0	12.0	Q2

**TAPE AND REEL BOX DIMENSIONS**

\*All dimensions are nominal

Device	Package Type	Package Drawing	Pins	SPQ	Length (mm)	Width (mm)	Height (mm)
SN65MLVD2DRBR	SON	DRB	8	3000	367.0	367.0	35.0
SN65MLVD2DRBT	SON	DRB	8	250	210.0	185.0	35.0
SN65MLVD3DRBR	SON	DRB	8	3000	367.0	367.0	35.0
SN65MLVD3DRBT	SON	DRB	8	250	210.0	185.0	35.0

**DRB 8**

**GENERIC PACKAGE VIEW**

**VSON - 1 mm max height**

PLASTIC SMALL OUTLINE - NO LEAD

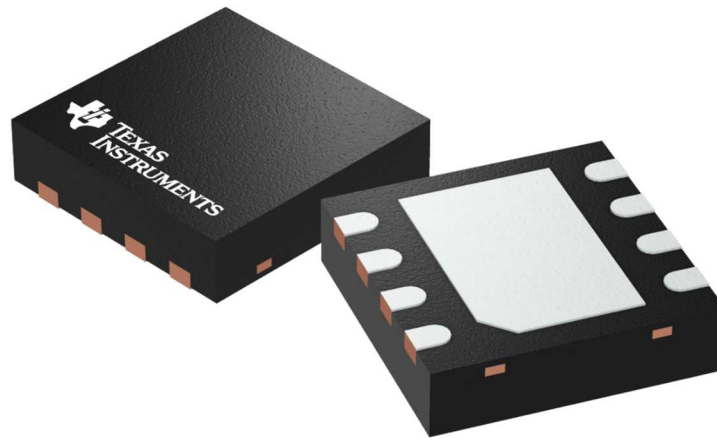

Images above are just a representation of the package family, actual package may vary.  
Refer to the product data sheet for package details.

4203482/L

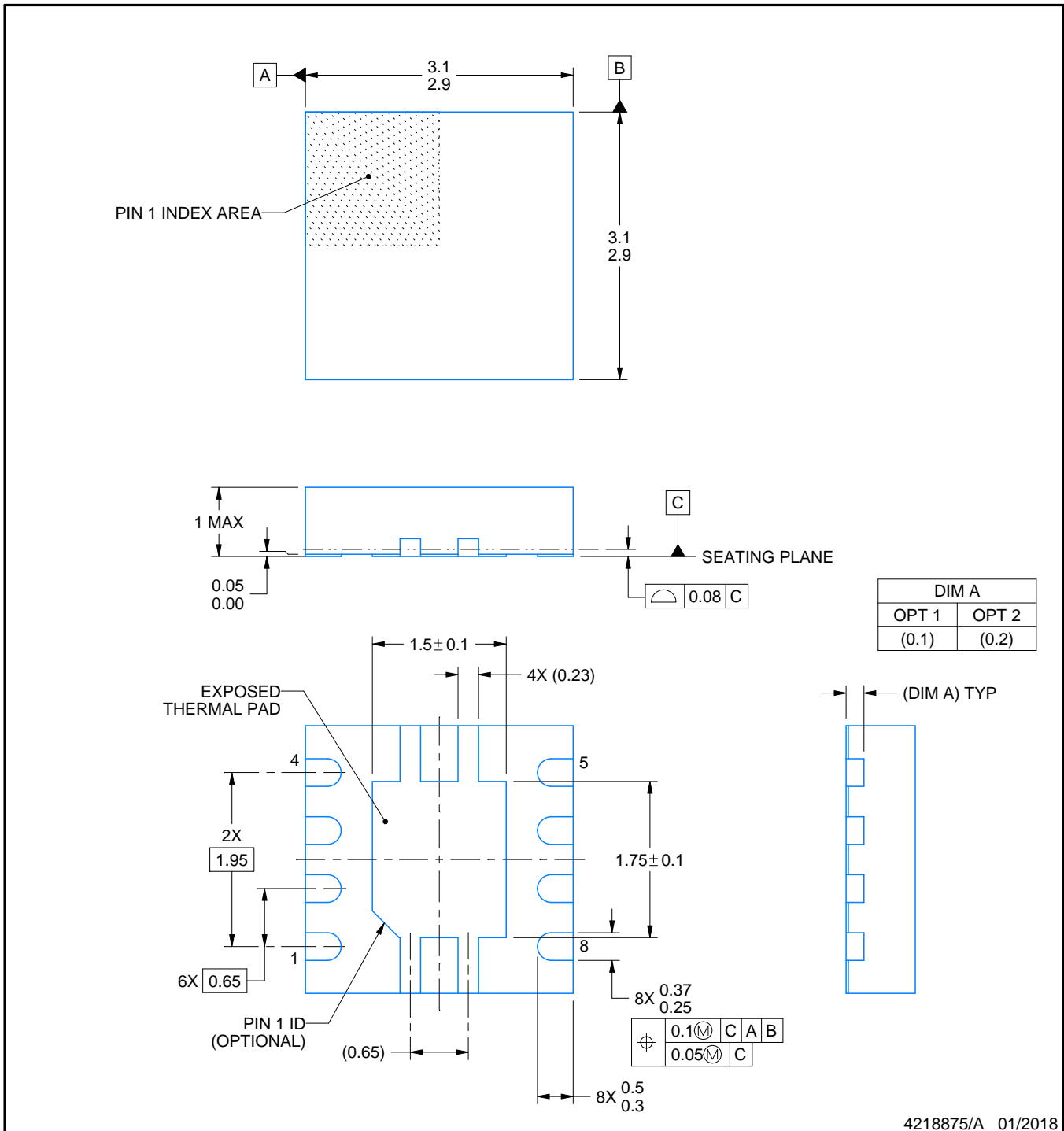

4218875/A 01/2018

NOTES:

1. All linear dimensions are in millimeters. Any dimensions in parenthesis are for reference only. Dimensioning and tolerancing per ASME Y14.5M.
2. This drawing is subject to change without notice.
3. The package thermal pad must be soldered to the printed circuit board for thermal and mechanical performance.

# EXAMPLE BOARD LAYOUT

DRB0008A

VSON - 1 mm max height

PLASTIC SMALL OUTLINE - NO LEAD

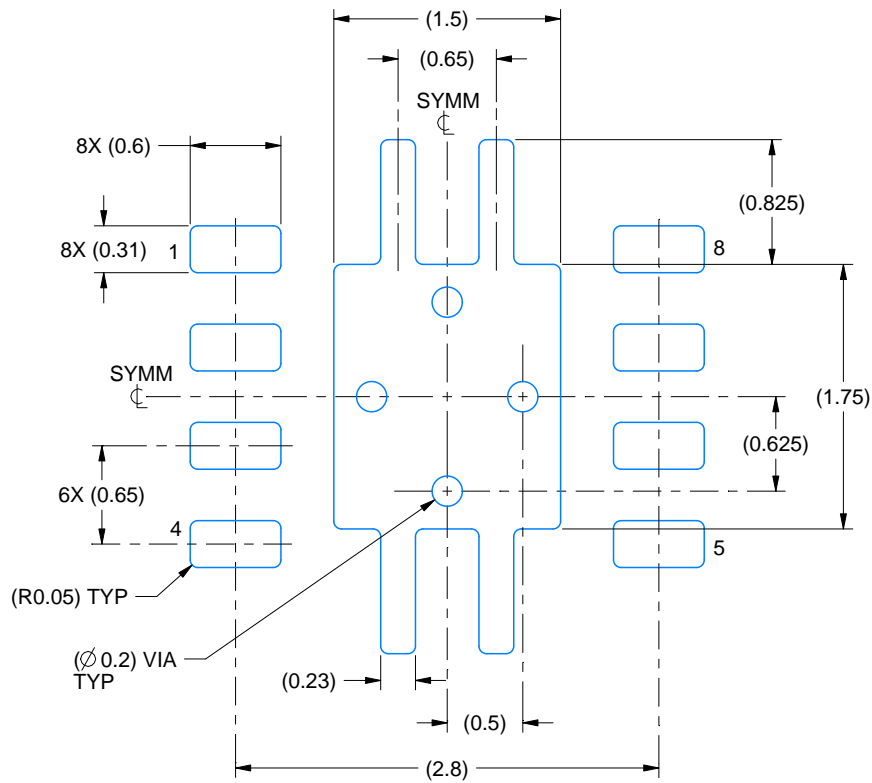

LAND PATTERN EXAMPLE  
EXPOSED METAL SHOWN  
SCALE:20X

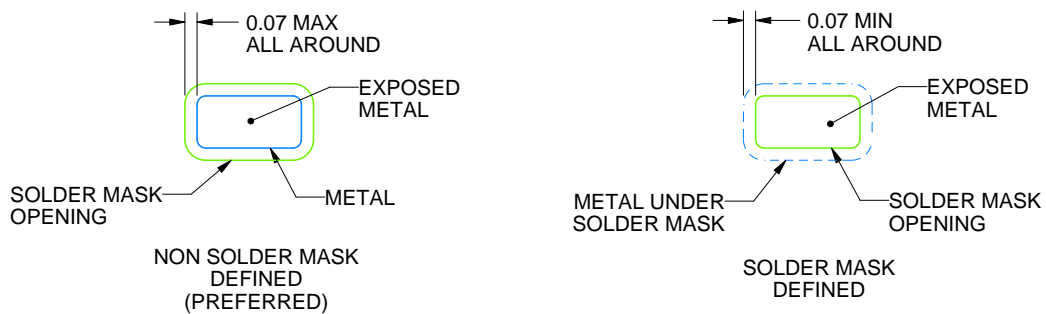

SOLDER MASK DETAILS

4218875/A 01/2018

NOTES: (continued)

4. This package is designed to be soldered to a thermal pad on the board. For more information, see Texas Instruments literature number SLUA271 ([www.ti.com/lit/slua271](http://www.ti.com/lit/slua271)).
5. Vias are optional depending on application, refer to device data sheet. If any vias are implemented, refer to their locations shown on this view. It is recommended that vias under paste be filled, plugged or tented.

# EXAMPLE STENCIL DESIGN

DRB0008A

VSON - 1 mm max height

PLASTIC SMALL OUTLINE - NO LEAD

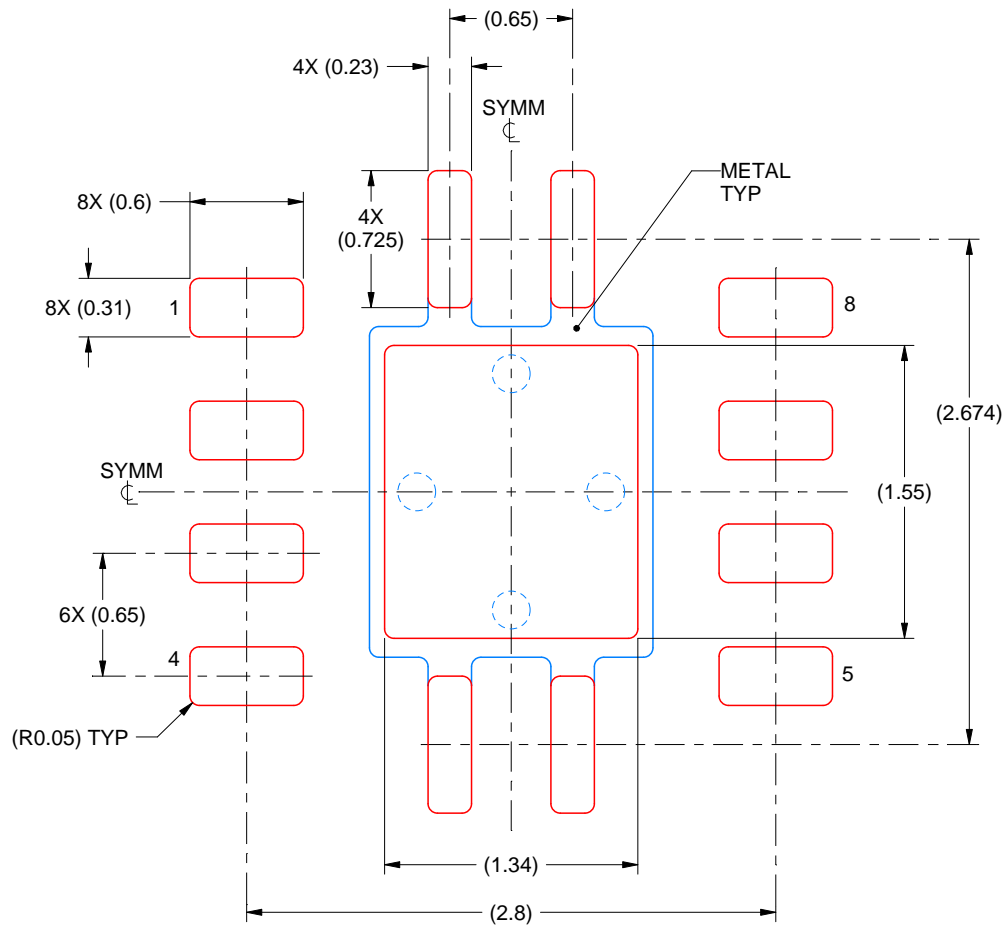

SOLDER PASTE EXAMPLE  
BASED ON 0.125 mm THICK STENCIL

EXPOSED PAD  
84% PRINTED SOLDER COVERAGE BY AREA  
SCALE:25X

4218875/A 01/2018

NOTES: (continued)

6. Laser cutting apertures with trapezoidal walls and rounded corners may offer better paste release. IPC-7525 may have alternate design recommendations.

## IMPORTANT NOTICE

Texas Instruments Incorporated (TI) reserves the right to make corrections, enhancements, improvements and other changes to its semiconductor products and services per JESD46, latest issue, and to discontinue any product or service per JESD48, latest issue. Buyers should obtain the latest relevant information before placing orders and should verify that such information is current and complete.

TI's published terms of sale for semiconductor products (<http://www.ti.com/sc/docs/stdterms.htm>) apply to the sale of packaged integrated circuit products that TI has qualified and released to market. Additional terms may apply to the use or sale of other types of TI products and services.

Reproduction of significant portions of TI information in TI data sheets is permissible only if reproduction is without alteration and is accompanied by all associated warranties, conditions, limitations, and notices. TI is not responsible or liable for such reproduced documentation. Information of third parties may be subject to additional restrictions. Resale of TI products or services with statements different from or beyond the parameters stated by TI for that product or service voids all express and any implied warranties for the associated TI product or service and is an unfair and deceptive business practice. TI is not responsible or liable for any such statements.

Buyers and others who are developing systems that incorporate TI products (collectively, "Designers") understand and agree that Designers remain responsible for using their independent analysis, evaluation and judgment in designing their applications and that Designers have full and exclusive responsibility to assure the safety of Designers' applications and compliance of their applications (and of all TI products used in or for Designers' applications) with all applicable regulations, laws and other applicable requirements. Designer represents that, with respect to their applications, Designer has all the necessary expertise to create and implement safeguards that (1) anticipate dangerous consequences of failures, (2) monitor failures and their consequences, and (3) lessen the likelihood of failures that might cause harm and take appropriate actions. Designer agrees that prior to using or distributing any applications that include TI products, Designer will thoroughly test such applications and the functionality of such TI products as used in such applications.

TI's provision of technical, application or other design advice, quality characterization, reliability data or other services or information, including, but not limited to, reference designs and materials relating to evaluation modules, (collectively, "TI Resources") are intended to assist designers who are developing applications that incorporate TI products; by downloading, accessing or using TI Resources in any way, Designer (individually or, if Designer is acting on behalf of a company, Designer's company) agrees to use any particular TI Resource solely for this purpose and subject to the terms of this Notice.

TI's provision of TI Resources does not expand or otherwise alter TI's applicable published warranties or warranty disclaimers for TI products, and no additional obligations or liabilities arise from TI providing such TI Resources. TI reserves the right to make corrections, enhancements, improvements and other changes to its TI Resources. TI has not conducted any testing other than that specifically described in the published documentation for a particular TI Resource.

Designer is authorized to use, copy and modify any individual TI Resource only in connection with the development of applications that include the TI product(s) identified in such TI Resource. NO OTHER LICENSE, EXPRESS OR IMPLIED, BY ESTOPPEL OR OTHERWISE TO ANY OTHER TI INTELLECTUAL PROPERTY RIGHT, AND NO LICENSE TO ANY TECHNOLOGY OR INTELLECTUAL PROPERTY RIGHT OF TI OR ANY THIRD PARTY IS GRANTED HEREIN, including but not limited to any patent right, copyright, mask work right, or other intellectual property right relating to any combination, machine, or process in which TI products or services are used. Information regarding or referencing third-party products or services does not constitute a license to use such products or services, or a warranty or endorsement thereof. Use of TI Resources may require a license from a third party under the patents or other intellectual property of the third party, or a license from TI under the patents or other intellectual property of TI.

TI RESOURCES ARE PROVIDED "AS IS" AND WITH ALL FAULTS. TI DISCLAIMS ALL OTHER WARRANTIES OR REPRESENTATIONS, EXPRESS OR IMPLIED, REGARDING RESOURCES OR USE THEREOF, INCLUDING BUT NOT LIMITED TO ACCURACY OR COMPLETENESS, TITLE, ANY EPIDEMIC FAILURE WARRANTY AND ANY IMPLIED WARRANTIES OF MERCHANTABILITY, FITNESS FOR A PARTICULAR PURPOSE, AND NON-INFRINGEMENT OF ANY THIRD PARTY INTELLECTUAL PROPERTY RIGHTS. TI SHALL NOT BE LIABLE FOR AND SHALL NOT DEFEND OR INDEMNIFY DESIGNER AGAINST ANY CLAIM, INCLUDING BUT NOT LIMITED TO ANY INFRINGEMENT CLAIM THAT RELATES TO OR IS BASED ON ANY COMBINATION OF PRODUCTS EVEN IF DESCRIBED IN TI RESOURCES OR OTHERWISE. IN NO EVENT SHALL TI BE LIABLE FOR ANY ACTUAL, DIRECT, SPECIAL, COLLATERAL, INDIRECT, PUNITIVE, INCIDENTAL, CONSEQUENTIAL OR EXEMPLARY DAMAGES IN CONNECTION WITH OR ARISING OUT OF TI RESOURCES OR USE THEREOF, AND REGARDLESS OF WHETHER TI HAS BEEN ADVISED OF THE POSSIBILITY OF SUCH DAMAGES.

Unless TI has explicitly designated an individual product as meeting the requirements of a particular industry standard (e.g., ISO/TS 16949 and ISO 26262), TI is not responsible for any failure to meet such industry standard requirements.

Where TI specifically promotes products as facilitating functional safety or as compliant with industry functional safety standards, such products are intended to help enable customers to design and create their own applications that meet applicable functional safety standards and requirements. Using products in an application does not by itself establish any safety features in the application. Designers must ensure compliance with safety-related requirements and standards applicable to their applications. Designer may not use any TI products in life-critical medical equipment unless authorized officers of the parties have executed a special contract specifically governing such use. Life-critical medical equipment is medical equipment where failure of such equipment would cause serious bodily injury or death (e.g., life support, pacemakers, defibrillators, heart pumps, neurostimulators, and implantables). Such equipment includes, without limitation, all medical devices identified by the U.S. Food and Drug Administration as Class III devices and equivalent classifications outside the U.S.

TI may expressly designate certain products as completing a particular qualification (e.g., Q100, Military Grade, or Enhanced Product). Designers agree that it has the necessary expertise to select the product with the appropriate qualification designation for their applications and that proper product selection is at Designers' own risk. Designers are solely responsible for compliance with all legal and regulatory requirements in connection with such selection.

Designer will fully indemnify TI and its representatives against any damages, costs, losses, and/or liabilities arising out of Designer's non-compliance with the terms and provisions of this Notice.

## Looking for pricing, stock, or lifecycle information?

Click below to explore more details on WIN SOURCE:

 [View SN65MLVD3DRBTG4 on WIN SOURCE](#)

 [Texas Instruments](#) Information

## Optimize Your Supply Chain with WIN SOURCE Solutions

-  Global Sourcing Solution
-  Obsolete Management
-  Cost Control Management
-  Shortage Management
-  Alternative Solution
-  Excess Inventory Management