



**THE DATASHEET OF
TLV3542IDGKT**



TLV354x 200-MHz, Rail-to-Rail I/O, CMOS Operational Amplifiers for Cost-Sensitive Systems

1 Features

- Wide-Bandwidth Amplifier for Cost-Sensitive Systems
- Unity-Gain Bandwidth: 200 MHz
- High Slew Rate: 150 V/ μ s
- Low Noise: 7.5 nV/ $\sqrt{\text{Hz}}$
- Rail-to-Rail I/O
- High Output Current: > 100 mA
- Excellent Video Performance:
 - Diff Gain: 0.02%, Diff Phase: 0.09°
 - 0.1-dB Gain Flatness: 40 MHz
- Low Input Bias Current: 3 pA
- Quiescent Current: 5.2 mA
- Thermal Shutdown
- Supply Range: 2.5 V to 5.5 V

2 Applications

- High-Resolution ADC Driver Amplifiers
- IR Touch
- Low-Voltage, High-Frequency Signal Processing
- Video Processing
- Base Transceiver Stations
- Optical Networking, Tunable Lasers
- Photodiode Transimpedance Amplifiers
- Barcode Scanners
- Fast Current-Sensing Amplifiers
- Ultrasound Imaging

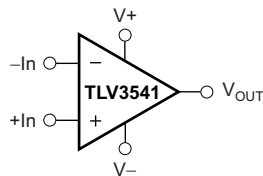

Figure 1. Simplified Schematic

3 Description

The TLV3541, TLV3542 and TLV3544 are single-, dual-, and quad-channel, low-power (5.2-mA per channel), high-speed, unity-gain stable, rail-to-rail input/output operational amplifiers (op amps) designed for video and other applications that require wide bandwidth.

Consuming only 6.5 mA (maximum) of supply current, these devices feature 200-MHz gain-bandwidth product, 150-V/ μ s slew rate, and a low 7.5 nV/ $\sqrt{\text{Hz}}$ of input noise at $f = 1$ MHz. The combination of high bandwidth, high slew rate, and low noise make the TLV354x family suitable for low voltage, high-speed signal conditioning systems.

The TLV354x series of op amps are optimized for operation on single or dual supplies as low as 2.5 V (± 1.25 V) and up to 5.5 V (± 2.75 V). Common-mode input range extends beyond the supplies. The output swing is within 100 mV of the rails, and supports a wide dynamic range.

The TLV354x devices are specified from -40°C to $+125^{\circ}\text{C}$. The TLV354x family can be used as a plug-in replacement for many commercially available wide bandwidth op amps.

Device Information⁽¹⁾

PART NUMBER	PACKAGE	BODY SIZE (NOM)
TLV3541	SOIC (8)	3.91 mm x 4.90 mm
	SOT-23 (5)	2.90 mm x 1.60 mm
TLV3542	SOIC (8)	3.91 mm x 4.90 mm
	VSSOP (8)	3.00 mm x 3.00 mm
TLV3544	SOIC (14)	8.65 mm x 3.91 mm
	TSSOP (14)	5.00 mm x 4.40 mm

(1) For all available packages, see the orderable addendum at the end of the data sheet.



Table of Contents

1 Features	1	8 Application and Implementation	19
2 Applications	1	8.1 Application Information.....	19
3 Description	1	8.2 Typical Application	19
4 Revision History	2	8.3 System Examples	20
5 Pin Configuration and Functions	3	9 Power Supply Recommendations	21
6 Specifications	5	9.1 Input and ESD Protection	21
6.1 Absolute Maximum Ratings	5	10 Layout	22
6.2 ESD Ratings.....	5	10.1 Layout Guidelines	22
6.3 Recommended Operating Conditions.....	5	10.2 Layout Example	22
6.4 Thermal Information: TLV3541	6	11 Device and Documentation Support	23
6.5 Thermal Information: TLV3542	6	11.1 Documentation Support	23
6.6 Thermal Information: TLV3544	6	11.2 Related Links	23
6.7 Electrical Characteristics: $V_S = 2.7\text{ V to }5.5\text{ V Single-Supply}$	7	11.3 Receiving Notification of Documentation Updates	23
6.8 Typical Characteristics	9	11.4 Community Resources.....	23
7 Detailed Description	13	11.5 Trademarks	23
7.1 Overview	13	11.6 Electrostatic Discharge Caution.....	23
7.2 Functional Block Diagram	13	11.7 Glossary	23
7.3 Feature Description.....	14	12 Mechanical, Packaging, and Orderable Information	24
7.4 Device Functional Modes.....	18		

4 Revision History

DATE	REVISION	NOTES
October 2016	*	Initial release.

5 Pin Configuration and Functions

**TLV3541: DBV Package
5-Pin SOT-23
Top View**

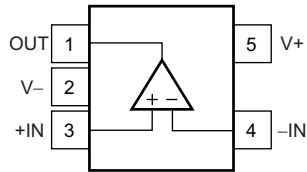

**TLV3541: D Package
8-Pin SOIC
Top View**

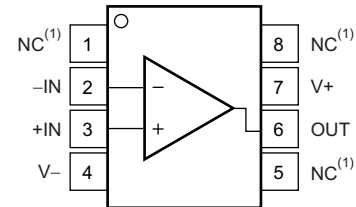

(1) NC means no internal connection.

Pin Functions: TLV3541

NAME	PIN		I/O	DESCRIPTION
	DBV (SOT-23)	D (SOIC)		
-IN	4	2	I	Inverting input
+IN	3	3	I	Noninverting input
NC	—	1, 5, 8	—	No internal connection (can be left floating)
OUT	1	6	O	Output
V-	2	4	—	Negative (lowest) supply
V+	5	7	—	Positive (highest) supply

**TLV3542: DGK and D Packages
8-Pin VSSOP, SOIC
Top View**

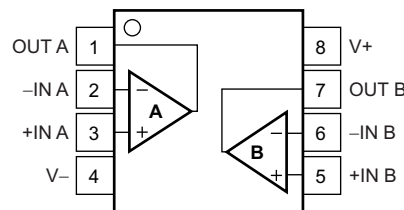

Pin Functions: TLV3542

NAME	PIN		I/O	DESCRIPTION
	NO.			
-IN A	2		I	Inverting input, channel A
+IN A	3		I	Noninverting input, channel A
-IN B	6		I	Inverting input, channel B
+IN B	5		I	Noninverting input, channel B
OUT A	1		O	Output, channel A
OUT B	7		O	Output, channel B
V-	4		—	Negative (lowest) supply
V+	8		—	Positive (highest) supply

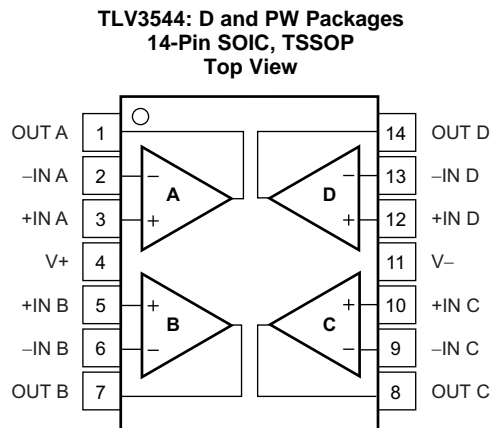
Pin Functions: TLV3544

NAME	PIN		I/O	DESCRIPTION
	TLV3544			
	D (SOIC)	PW (TSSOP)		
-IN A	2	2	I	Inverting input, channel A
-IN B	6	6	I	Inverting input, channel B
-IN C	9	9	I	Inverting input, channel C
-IN D	13	13	I	Inverting input, channel D
+IN A	3	3	I	Noninverting input, channel A
+IN B	5	5	I	Noninverting input, channel B
+IN C	10	10	I	Noninverting input, channel C
+IN D	12	12	I	Noninverting input, channel D
OUT A	1	1	O	Output, channel A
OUT B	7	7	O	Output, channel B
OUT C	8	8	O	Output, channel C
OUT D	14	14	O	Output, channel D
V-	11	11	—	Negative (lowest) supply
V+	4	4	—	Positive (highest) supply

6 Specifications

6.1 Absolute Maximum Ratings

over operating free-air temperature range (unless otherwise noted)⁽¹⁾

		MIN	MAX	UNIT
Voltage	Supply voltage, V+ to V-		7.5	V
	Signal input terminals ⁽²⁾	(V-) - (0.5)	(V+) + 0.5	V
Current	Signal input terminals ⁽²⁾	-10	10	mA
	Output short circuit ⁽³⁾	Continuous		
Temperature	Operating, T _A	-55	150	°C
	Junction, T _J	-65	150	°C
	Storage, T _{stg}		150	°C

- (1) Stresses beyond those listed under *Absolute Maximum Ratings* may cause permanent damage to the device. These are stress ratings only, which do not imply functional operation of the device at these or any other conditions beyond those indicated under *Recommended Operating Conditions*. Exposure to absolute-maximum-rated conditions for extended periods may affect device reliability.
- (2) Input pins are diode-clamped to the power-supply rails. Input signals that can swing more than 0.5 V beyond the supply rails must be current limited to 10 mA or less.
- (3) Short-circuit to ground, one amplifier per package.

6.2 ESD Ratings

		VALUE	UNIT
V _(ESD) Electrostatic discharge	Human-body model (HBM), per ANSI/ESDA/JEDEC JS-001 ⁽¹⁾	1000	V
	Charged-device model (CDM), per JEDEC specification JESD22-C101 ⁽²⁾	250	

- (1) JEDEC document JEP155 states that 500-V HBM allows safe manufacturing with a standard ESD control process.
- (2) JEDEC document JEP157 states that 250-V CDM allows safe manufacturing with a standard ESD control process.

6.3 Recommended Operating Conditions

over operating free-air temperature range (unless otherwise noted)

		MIN	NOM	MAX	UNIT
V _S	Supply voltage, V- to V+	2.5		5.5	V
	Specified temperature range	-40		125	°C

6.4 Thermal Information: TLV3541

THERMAL METRIC ⁽¹⁾		TLV3541		UNIT
		D (SOIC)	DBV (SOT-23)	
		8 PINS	5 PINS	
$R_{\theta JA}$	Junction-to-ambient thermal resistance	123.8	216.3	°C/W
$R_{\theta JC(top)}$	Junction-to-case (top) thermal resistance	68.7	84.3	°C/W
$R_{\theta JB}$	Junction-to-board thermal resistance	64.5	43.1	°C/W
Ψ_{JT}	Junction-to-top characterization parameter	23.0	3.8	°C/W
Ψ_{JB}	Junction-to-board characterization parameter	64.0	42.3	°C/W
$R_{\theta JC(bot)}$	Junction-to-case (bottom) thermal resistance	N/A	N/A	°C/W

(1) For more information about traditional and new thermal metrics, see [Semiconductor and IC Package Thermal Metrics](#) (SPRA953).

6.5 Thermal Information: TLV3542

THERMAL METRIC ⁽¹⁾		TLV3542		UNIT
		D (SOIC)	DGK (VSSOP)	
		8 PINS	8 PINS	
$R_{\theta JA}$	Junction-to-ambient thermal resistance	113.9	175.9	°C/W
$R_{\theta JC(top)}$	Junction-to-case (top) thermal resistance	60.4	67.8	°C/W
$R_{\theta JB}$	Junction-to-board thermal resistance	54.1	97.1	°C/W
Ψ_{JT}	Junction-to-top characterization parameter	17.1	9.3	°C/W
Ψ_{JB}	Junction-to-board characterization parameter	53.6	95.5	°C/W
$R_{\theta JC(bot)}$	Junction-to-case (bottom) thermal resistance	N/A	N/A	°C/W

(1) For more information about traditional and new thermal metrics, see [Semiconductor and IC Package Thermal Metrics](#) (SPRA953).

6.6 Thermal Information: TLV3544

THERMAL METRIC ⁽¹⁾		TLV3544		UNIT
		D (SOIC)	PW (TSSOP)	
		14 PINS	14 PINS	
$R_{\theta JA}$	Junction-to-ambient thermal resistance	83.8	92.6	°C/W
$R_{\theta JC(top)}$	Junction-to-case (top) thermal resistance	70.7	27.5	°C/W
$R_{\theta JB}$	Junction-to-board thermal resistance	59.5	33.6	°C/W
Ψ_{JT}	Junction-to-top characterization parameter	11.6	1.9	°C/W
Ψ_{JB}	Junction-to-board characterization parameter	37.7	33.1	°C/W
$R_{\theta JC(bot)}$	Junction-to-case (bottom) thermal resistance	N/A	N/A	°C/W

(1) For more information about traditional and new thermal metrics, see [Semiconductor and IC Package Thermal Metrics](#) (SPRA953).

6.7 Electrical Characteristics: $V_S = 2.7\text{ V to }5.5\text{ V}$ Single-Supply

at $T_A = 25^\circ\text{C}$, $R_F = 0\ \Omega$, $R_L = 1\ \text{k}\Omega$, and connected to $V_S / 2$ (unless otherwise noted)

PARAMETER		TEST CONDITIONS	MIN	TYP	MAX	UNIT
OFFSET VOLTAGE						
V_{OS}	Input offset voltage	$V_S = 5\text{ V}$, at $T_A = 25^\circ\text{C}$		± 2	± 10	mV
dV_{OS}/dT	Input offset voltage vs temperature	$V_S = 5\text{ V}$, at $T_A = -40^\circ\text{C}$ to $+125^\circ\text{C}$		± 4.5		$\mu\text{V}/^\circ\text{C}$
PSRR	Input offset voltage vs power supply	$V_S = 2.7\text{ V to }5.5\text{ V}$, $V_{CM} = (V_S / 2) - 0.55\text{ V}$	60	70		dB
INPUT BIAS CURRENT						
I_B	Input bias current			3		pA
I_{OS}	Input offset current			± 1		pA
NOISE						
e_n	Input voltage noise density	$f = 1\text{ MHz}$		7.5		$\text{nV}/\sqrt{\text{Hz}}$
i_n	Current noise density	$f = 1\text{ MHz}$		50		$\text{fA}/\sqrt{\text{Hz}}$
INPUT VOLTAGE RANGE						
V_{CM}	Common-mode voltage range		$(V-) - 0.1$		$(V+) + 0.1$	V
CMRR	Common-mode rejection ratio	$V_S = 5.5\text{ V}$, $-0.1\text{ V} < V_{CM} < 3.5\text{ V}$, at $T_A = 25^\circ\text{C}$	66	80		dB
		$V_S = 5.5\text{ V}$, $-0.1\text{ V} < V_{CM} < 5.6\text{ V}$, at $T_A = 25^\circ\text{C}$	56	68		dB
INPUT IMPEDANCE						
	Differential			$10^{13} \parallel 2$		$\Omega \parallel \text{pF}$
	Common-mode			$10^{13} \parallel 2$		$\Omega \parallel \text{pF}$
OPEN-LOOP GAIN						
A_{OL}	Open-loop gain	$V_S = 5\text{ V}$, $0.3\text{ V} < V_O < 4.7\text{ V}$, at $T_A = 25^\circ\text{C}$	92	108		dB
FREQUENCY RESPONSE						
$f_{-3\text{dB}}$	Small-signal bandwidth	At $G = +1$, $V_O = 10\text{ mV}$ $R_F = 25\ \Omega$		200		MHz
		At $G = +2$, $V_O = 10\text{ mV}$		90		MHz
GBW	Gain-bandwidth product	$G = +10$		100		MHz
$f_{0.1\text{dB}}$	Bandwidth for 0.1-dB gain flatness	At $G = +2$, $V_O = 10\text{ mV}$		40		MHz
SR	Slew rate	$V_S = 5\text{ V}$, $G = +1$, 4-V step		150		$\text{V} / \mu\text{s}$
		$V_S = 5\text{ V}$, $G = +1$, 2-V step		130		$\text{V} / \mu\text{s}$
	Rise-and-fall time	At $G = +1$, $V_O = 200\text{ mV}_{PP}$, 10% to 90%		2		ns
		At $G = +1$, $V_O = 2\text{ V}_{PP}$, 10% to 90%		11		ns
	Settling time	0.1%, $V_S = 5\text{ V}$, $G = +1$, 2-V output step		30		ns
		0.01%, $V_S = 5\text{ V}$, $G = +1$, 2-V output step		60		ns
	Overload recovery time	$V_{IN} \times \text{Gain} = V_S$		5		ns

Electrical Characteristics: $V_S = 2.7\text{ V}$ to 5.5 V Single-Supply (continued)

 at $T_A = 25^\circ\text{C}$, $R_F = 0\ \Omega$, $R_L = 1\ \text{k}\Omega$, and connected to $V_S / 2$ (unless otherwise noted)

PARAMETER		TEST CONDITIONS	MIN	TYP	MAX	UNIT
FREQUENCY RESPONSE, continued						
Harmonic distortion	Second harmonic	At $G = +1$, $f = 1\ \text{MHz}$, $V_O = 2\ V_{PP}$, $R_L = 200\ \Omega$, $V_{CM} = 1.5\ \text{V}$		-75		dBc
	Third harmonic	At $G = +1$, $f = 1\ \text{MHz}$, $V_O = 2\ V_{PP}$, $R_L = 200\ \Omega$, $V_{CM} = 1.5\ \text{V}$		-83		dBc
Differential gain error		NTSC, $R_L = 150\ \Omega$		0.02%		
Differential phase error		NTSC, $R_L = 150\ \Omega$		0.09		°
Channel-to-channel crosstalk	TLV3542	$f = 5\ \text{MHz}$		-100		dB
	TLV3544			-84		dB
OUTPUT						
Voltage output swing from rail		$V_S = 5\ \text{V}$, $R_L = 1\ \text{k}\Omega$ at $T_A = 25^\circ\text{C}$		0.1	0.3	V
I_O	Output current, single, dual, quad ⁽¹⁾⁽²⁾	$V_S = 5\ \text{V}$	100			mA
		$V_S = 3\ \text{V}$		50		mA
Closed-loop output impedance		$f < 100\ \text{kHz}$		0.05		Ω
R_O	Open-loop output resistance			35		Ω
POWER SUPPLY						
V_S	Specified voltage range		2.7		5.5	V
	Operating voltage range		2.5		5.5	V
I_Q	Quiescent current (per amplifier)	At $T_A = 25^\circ\text{C}$, $V_S = 5\ \text{V}$, $I_O = 0$		5.2	6.5	mA
TEMPERATURE RANGE						
Specified range			-40		125	°C
Operating range ⁽³⁾			-55		150	°C
Storage range			-65		150	°C
THERMAL SHUTDOWN						
Shutdown temperature				160		°C
Reset from shutdown				140		°C

 (1) See typical characteristic curves, *Output Voltage Swing vs Output Current* (Figure 14 and Figure 15).

(2) Specified by design.

(3) Operating in this temperature range will not damage the part. However, degraded performance may be observed.

6.8 Typical Characteristics

at $T_A = 25^\circ\text{C}$, $V_S = 5\text{ V}$, $G = +1$, $R_F = 0\ \Omega$, $R_L = 1\ \text{k}\Omega$, and connected to $V_S / 2$, unless otherwise noted.

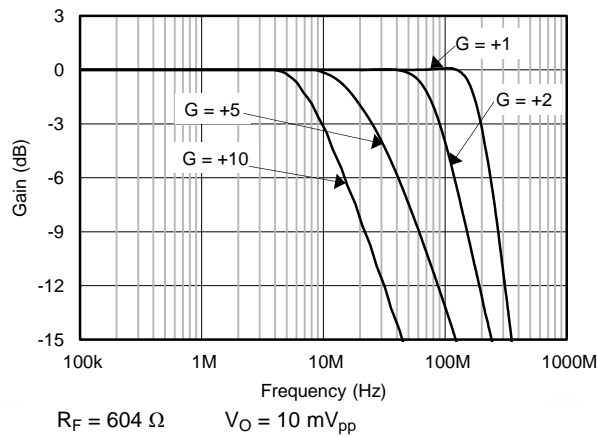

Figure 2. Noninverting Small-Signal Frequency Response

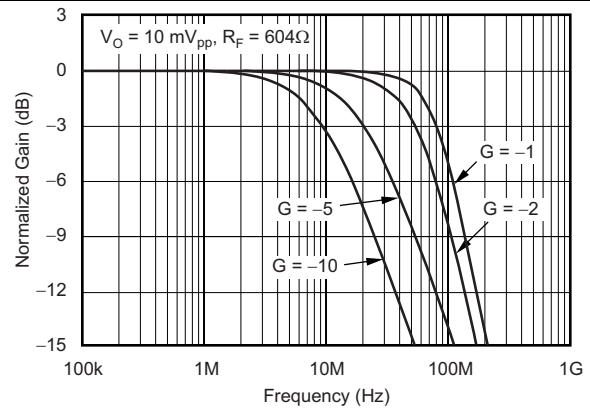

Figure 3. Inverting Small-Signal Frequency Response

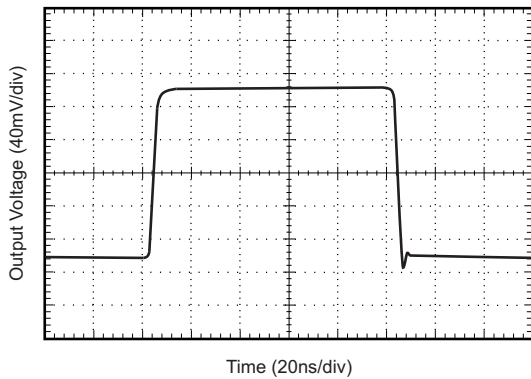

Figure 4. Noninverting Small-Signal Step Response

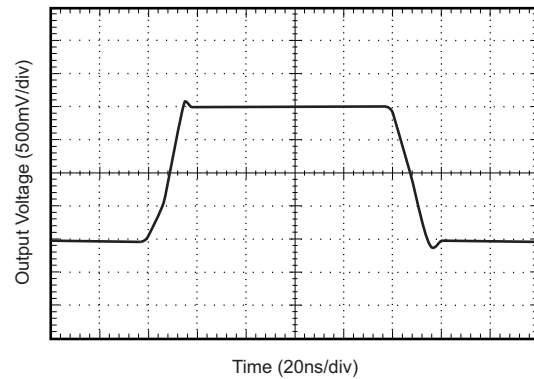

Figure 5. Noninverting Large-Signal Step Response

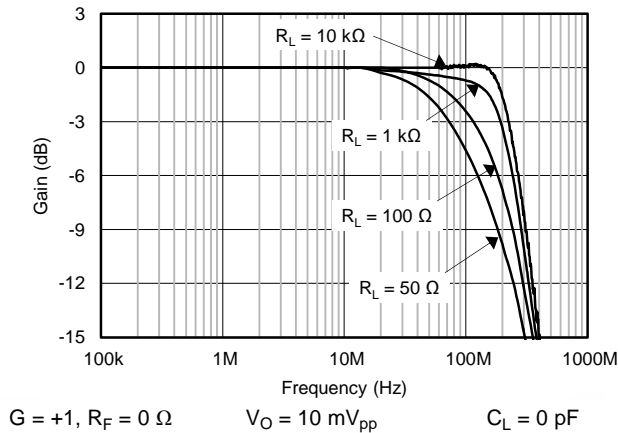

Figure 6. Frequency Response for Various R_L

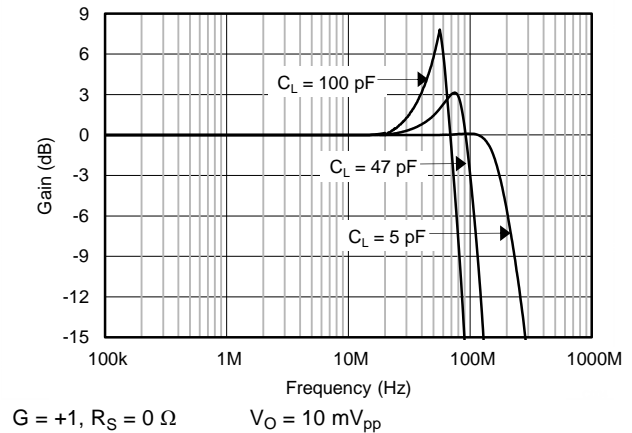

Figure 7. Frequency Response for Various C_L

Typical Characteristics (continued)

at $T_A = 25^\circ\text{C}$, $V_S = 5\text{ V}$, $G = +1$, $R_F = 0\ \Omega$, $R_L = 1\ \text{k}\Omega$, and connected to $V_S / 2$, unless otherwise noted.

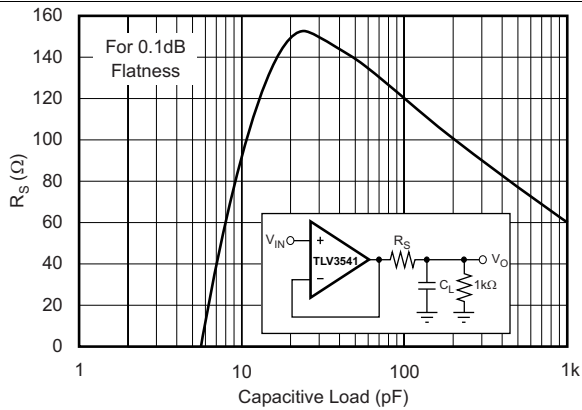

Figure 8. Recommended R_S vs Capacitive Load

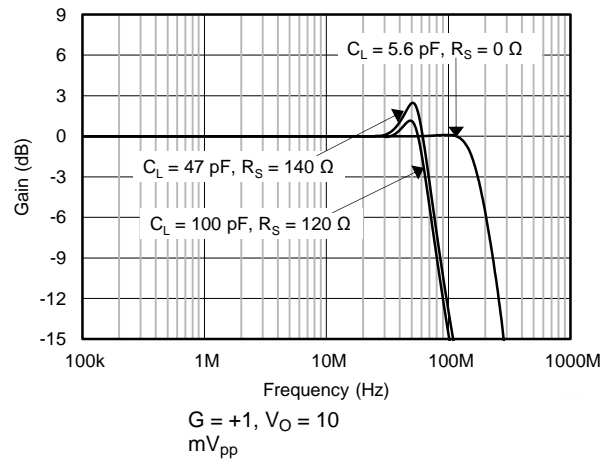

Figure 9. Frequency Response vs Capacitive Load

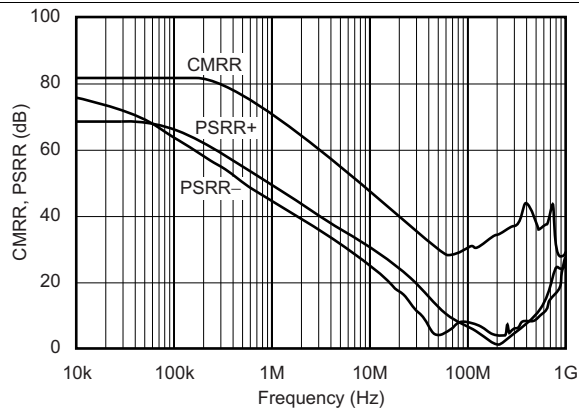

Figure 10. Common-Mode Rejection Ratio and Power-Supply Rejection Ratio vs Frequency

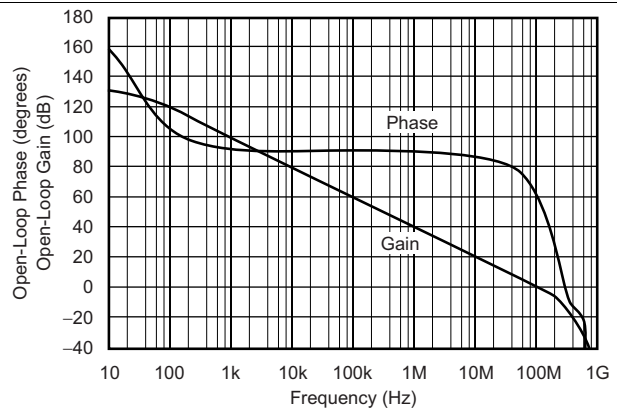

Figure 11. Open-Loop Gain and Phase

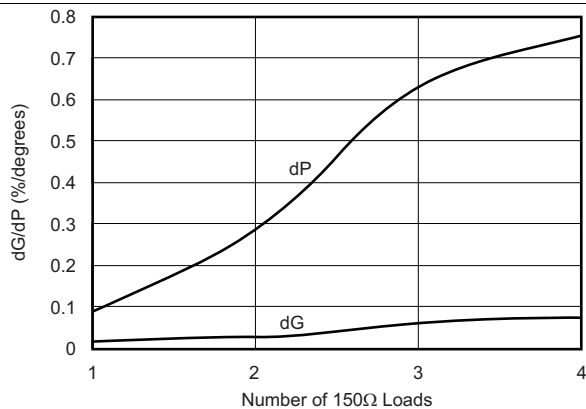

Figure 12. Composite Video Differential Gain and Phase

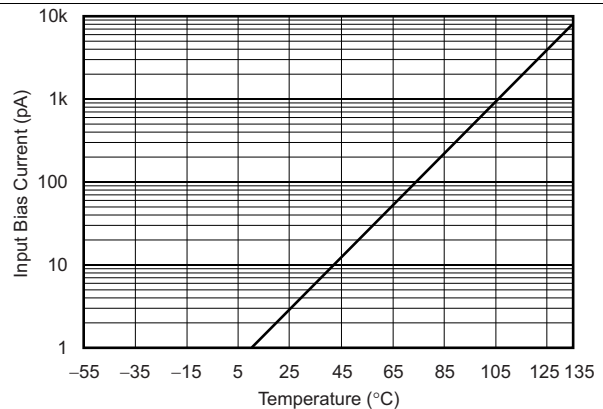

Figure 13. Input Bias Current vs Temperature

Typical Characteristics (continued)

at $T_A = 25^\circ\text{C}$, $V_S = 5\text{ V}$, $G = +1$, $R_F = 0\ \Omega$, $R_L = 1\ \text{k}\Omega$, and connected to $V_S / 2$, unless otherwise noted.

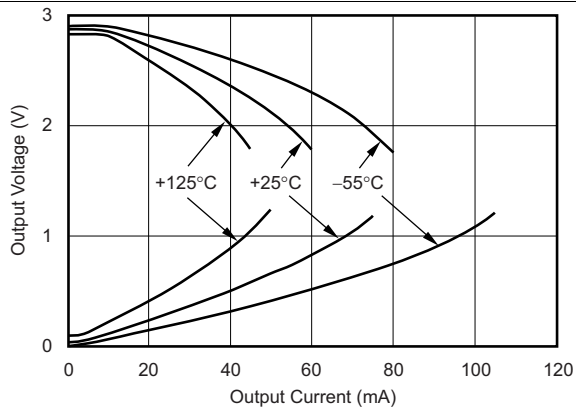

Figure 14. Output Voltage Swing vs Output Current for $V_S = 3\text{ V}$

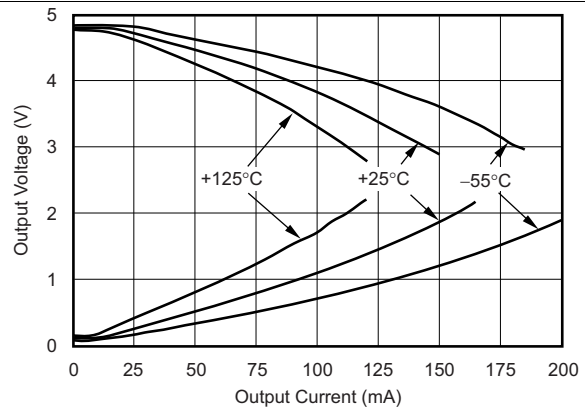

Figure 15. Output Voltage Swing vs Output Current for $V_S = 5\text{ V}$

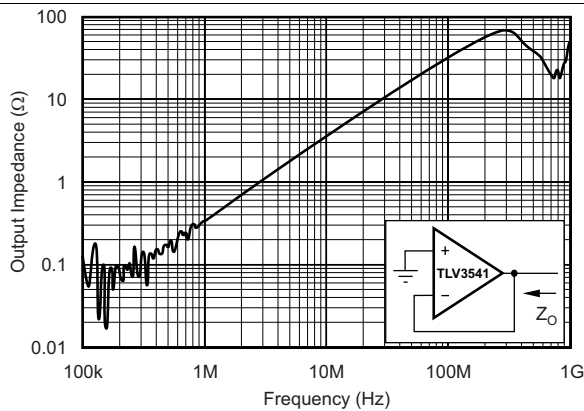

Figure 16. Closed-Loop Output Impedance vs Frequency

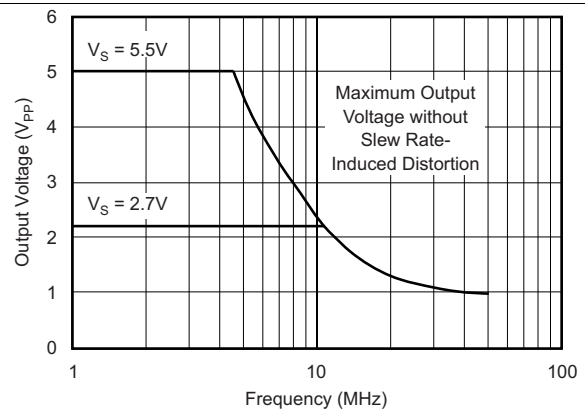

Figure 17. Maximum Output Voltage vs Frequency

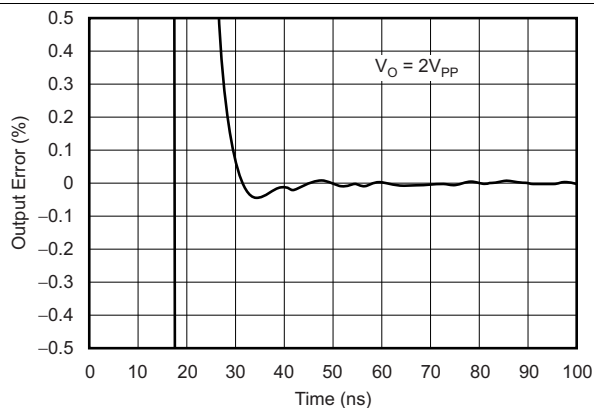

Figure 18. Output Settling Time to 0.1%

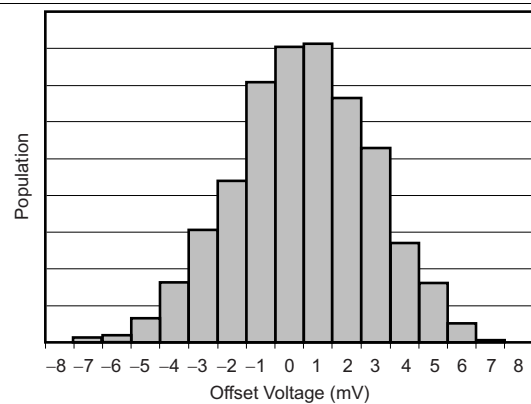
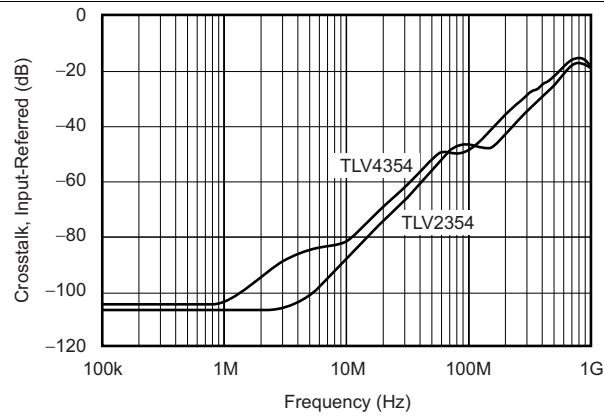

Figure 19. Offset Voltage Production Distribution

Typical Characteristics (continued)

 at $T_A = 25^\circ\text{C}$, $V_S = 5\text{ V}$, $G = +1$, $R_F = 0\ \Omega$, $R_L = 1\ \text{k}\Omega$, and connected to $V_S / 2$, unless otherwise noted.

Figure 20. Channel-to-Channel Crosstalk

7 Detailed Description

7.1 Overview

The TLV354x is a CMOS, rail-to-rail I/O, high-speed, voltage-feedback operational amplifier designed for video, high-speed, and other applications. The device is available as a single, dual, or quad op amp.

The amplifier features a 100-MHz gain bandwidth and a 150-V/ μ s slew rate, but the amplifier is unity-gain stable and operates as a +1-V/V voltage follower.

7.2 Functional Block Diagram

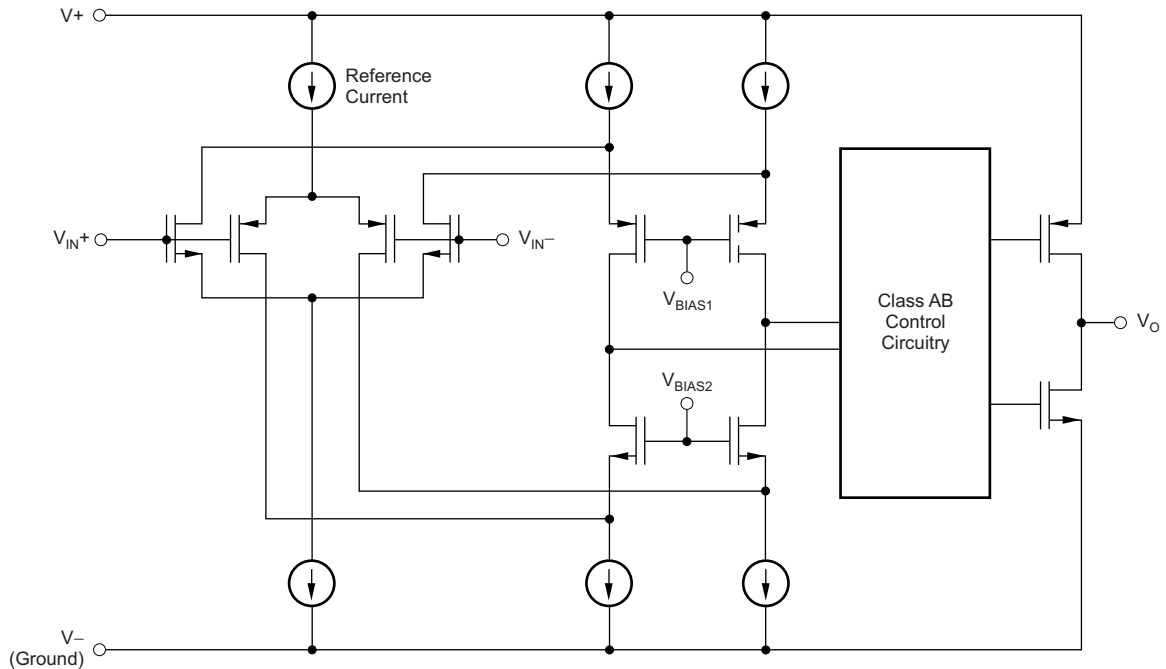

Copyright © 2016, Texas Instruments Incorporated

7.3 Feature Description

7.3.1 Operating Voltage

The TLV354x is specified over a power-supply range of 2.7 V to 5.5 V (± 1.35 V to ± 2.75 V). However, the supply voltage may range from 2.5 V to 5.5 V (± 1.25 V to ± 2.75 V). Supply voltages higher than 7.5 V (absolute maximum) can permanently damage the amplifier.

Parameters that vary over supply voltage or temperature are shown in the [Typical Characteristics](#) section.

7.3.2 Rail-to-Rail Input

The specified input common-mode voltage range of the TLV354x extends 100 mV beyond the supply rails. This extended range is achieved with a complementary input stage: an N-channel input differential pair in parallel with a P-channel differential pair, as shown in the [Functional Block Diagram](#). The N-channel pair is active for input voltages close to the positive rail, typically $(V+) - 1.2$ V to 100 mV above the positive supply, while the P-channel pair is on for inputs from 100 mV below the negative supply to approximately $(V+) - 1.2$ V. There is a small transition region, typically $(V+) - 1.5$ V to $(V+) - 0.9$ V, in which both pairs are on. This 600-mV transition region can vary ± 500 mV with process variation. Thus, the transition region (with both input stages on) can range from $(V+) - 2.0$ V to $(V+) - 1.5$ V on the low end, up to $(V+) - 0.9$ V to $(V+) - 0.4$ V on the high end.

A double-folded cascode adds the signal from the two input pairs and presents a differential signal to the class AB output stage.

7.3.3 Rail-to-Rail Output

A class AB output stage with common-source transistors is used to achieve rail-to-rail output. For high-impedance loads ($> 200 \Omega$), the output voltage swing is typically 100 mV from the supply rails. With 10- Ω loads, a useful output swing can be achieved while maintaining high open-loop gain. See the typical characteristic curves, *Output Voltage Swing vs Output Current* ([Figure 14](#) and [Figure 15](#)).

7.3.4 Output Drive

The TLV354x output stage can supply a continuous output current of ± 100 mA and yet provide approximately 2.7 V of output swing on a 5-V supply, as shown in [Figure 21](#). For maximum reliability, it is not recommended to run a continuous DC current in excess of ± 100 mA. Refer to the typical characteristic curves, *Output Voltage Swing vs Output Current* ([Figure 14](#) and [Figure 15](#)). For supplying continuous output currents greater than ± 100 mA, the TLV354x may be operated in parallel, as shown in [Figure 22](#).

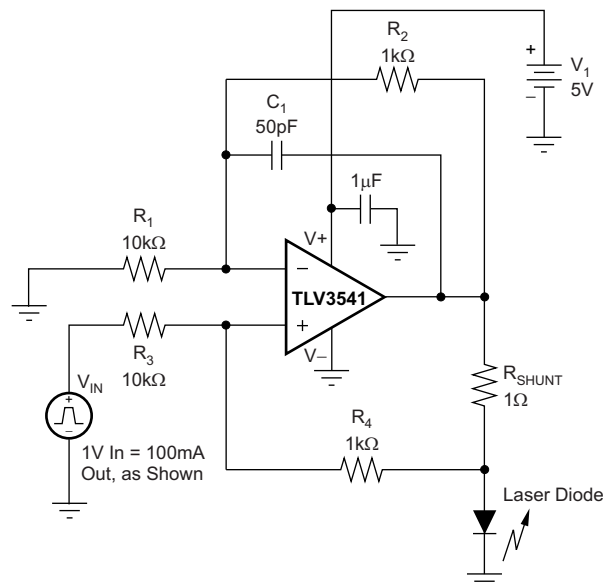

Figure 21. Laser Diode Driver

Feature Description (continued)

The TLV354x provides peak currents up to 200 mA, which corresponds to the typical short-circuit current. Therefore, an on-chip thermal shutdown circuit is provided to protect the TLV354x from dangerously high junction temperatures. At 160°C, the protection circuit shuts down the amplifier. Normal operation resumes when the junction temperature cools to below +140°C.

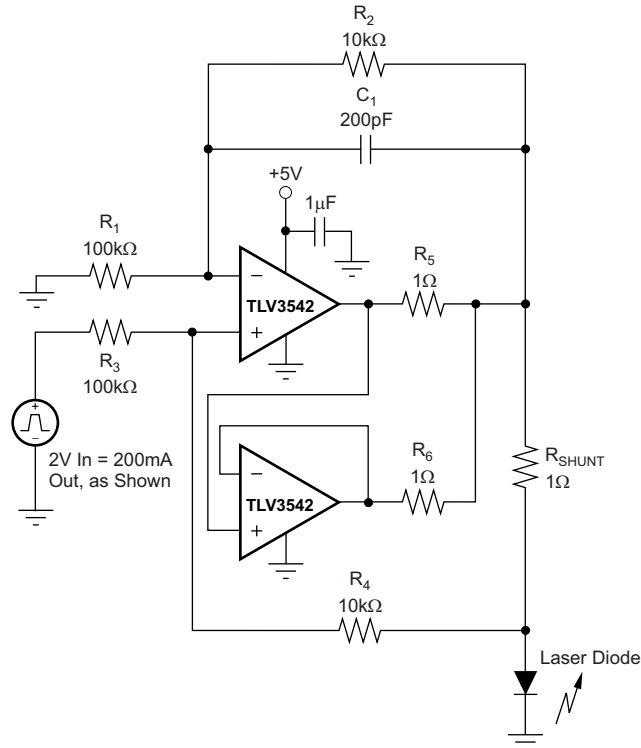

Figure 22. Parallel Operation

7.3.5 Video

The TLV354x output stage is capable of driving standard back-terminated 75-Ω video cables, as shown in Figure 23. By back-terminating a transmission line, the device does not exhibit a capacitive load to its driver. A properly back-terminated 75-Ω cable does not appear as capacitance; the device presents a 150-Ω resistive load to the TLV354x output.

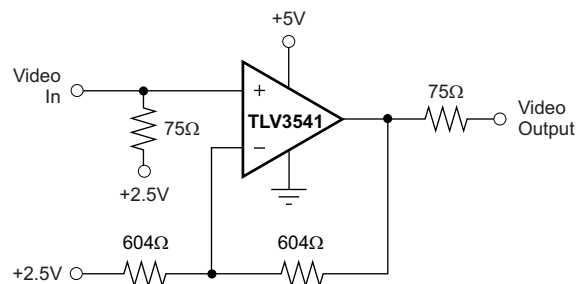
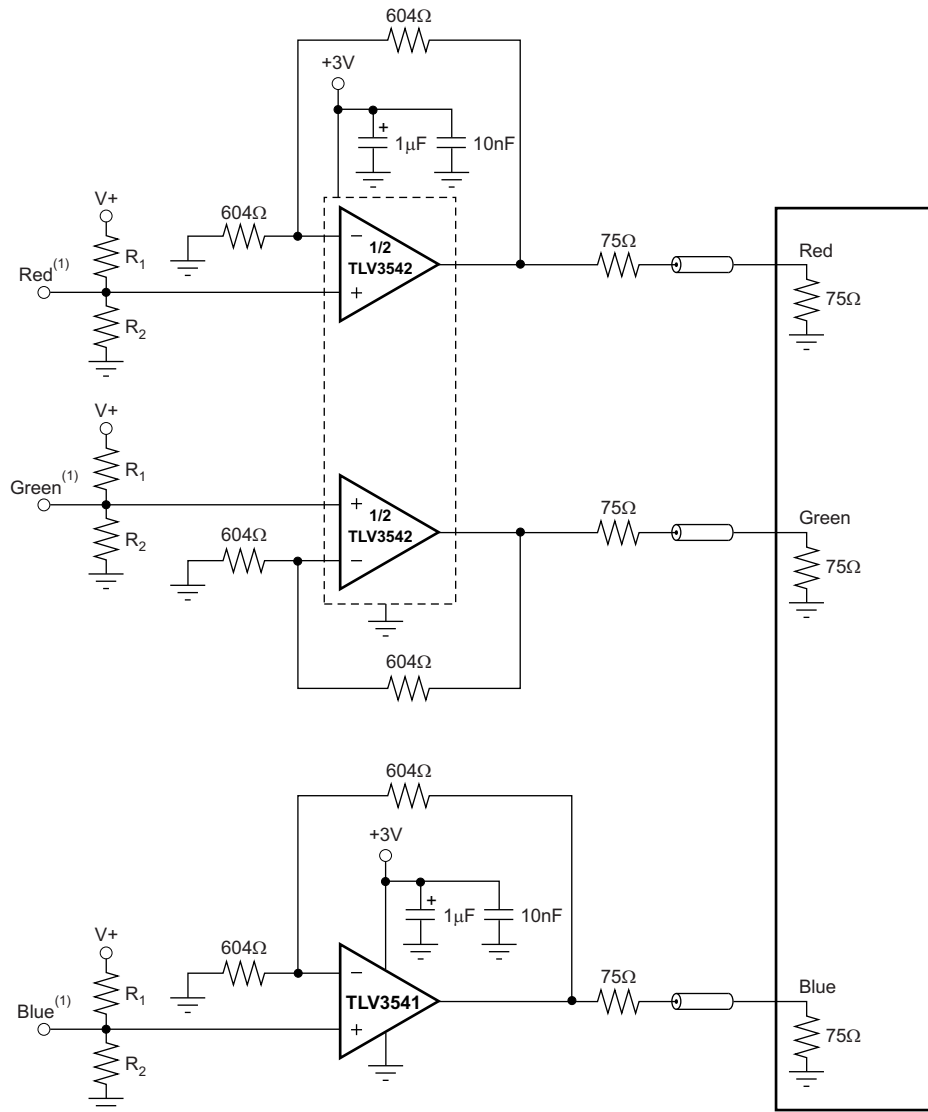

Figure 23. Single-Supply Video Line Driver

The TLV3542 can be used as an amplifier for RGB graphic signals, which have a voltage of zero at the video black level, by offsetting and AC-coupling the signal. See Figure 24.

Feature Description (continued)



(1) Source video signal offsets 300 mV above ground to accommodate op amp swing-to-ground capability.

Figure 24. RGB Cable Driver

Feature Description (continued)

7.3.6 Driving Analog-to-Digital Converters

The TLV354x series op amps offer 60 ns of settling time to 0.01%, making them a good choice for driving high- and medium-speed sampling A/D converters and buffering reference circuits. The TLV354x series provide an effective means of buffering the A/D converter input capacitance and resulting charge injection while providing signal gain. For applications requiring high DC accuracy, TI recommends using the [OPA350 series](#).

Figure 25 illustrates the TLV3541 driving an A/D converter. With the TLV3541 in an inverting configuration, a capacitor across the feedback resistor can filter high-frequency noise in the signal.

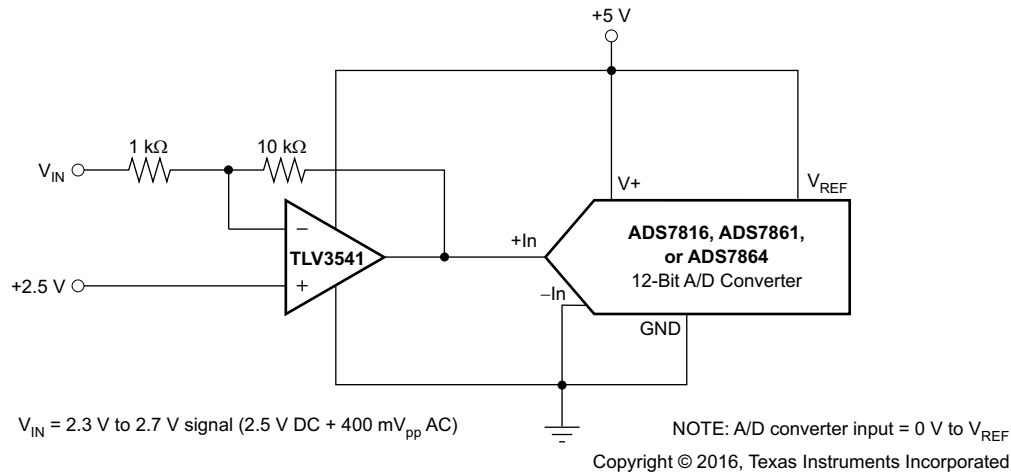

Figure 25. The TLV3541 in Inverting Configuration Driving the ADS7816

7.3.7 Capacitive Load and Stability

The TLV354x series op amps can drive a wide range of capacitive loads. However, all op amps under certain conditions may become unstable. Op amp configuration, gain, and load value are just a few of the factors to consider when determining stability. An op amp in unity-gain configuration is most susceptible to the effects of capacitive loading. The capacitive load reacts with the device output resistance, along with any additional load resistance, to create a pole in the small-signal response that degrades the phase margin. Refer to the typical characteristic curve, *Frequency Response for Various C_L* (Figure 7) for details.

The TLV354x topology enhances the ability to drive capacitive loads. In unity gain, these op amps perform well with large capacitive loads. Refer to the typical characteristic curves, *Recommended R_S vs Capacitive Load* (Figure 8) and *Frequency Response vs Capacitive Load* (Figure 9) for details.

One method of improving capacitive load drive in the unity-gain configuration is to insert a 10- Ω to 20- Ω resistor in series with the output, as shown in Figure 26. This configuration significantly reduces ringing with large capacitive loads. See the typical characteristic curve, *Frequency Response vs Capacitive Load* (Figure 9). However, if there is a resistive load in parallel with the capacitive load, R_S creates a voltage divider. This voltage division introduces a DC error at the output and slightly reduces output swing. This error may be insignificant. For instance, with $R_L = 10\text{ k}\Omega$ and $R_S = 20\ \Omega$, there is an error of approximately 0.2% at the output.

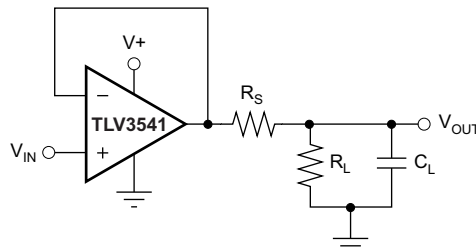

Figure 26. Series Resistor in Unity-Gain Configuration Improves Capacitive Load Drive

Feature Description (continued)

7.3.8 Wideband Transimpedance Amplifier

Wide bandwidth, low input bias current, and low input voltage and current noise make the TLV354x a suitable wideband photodiode transimpedance amplifier for low-voltage, single-supply applications. Low-voltage noise is important because photodiode capacitance causes the effective noise gain of the circuit to increase at high frequency.

The key elements to a transimpedance design, as shown in [Figure 27](#), are the expected diode capacitance (including the parasitic input common-mode and differential-mode input capacitance (2 + 2) pF for the TLV354x), the desired transimpedance gain (R_F), and the Gain-Bandwidth Product (GBW) for the TLV354x (100 MHz, typical). With these three variables set, the feedback capacitor value (C_F) may be set to control the frequency response.

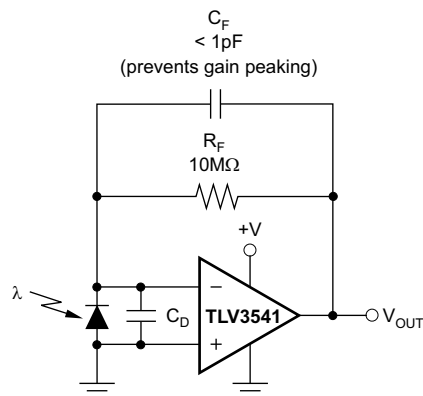

Figure 27. Transimpedance Amplifier

To achieve a flat, second-order, Butterworth frequency response, the feedback pole must be set as shown in [Equation 1](#):

$$\frac{1}{2\pi R_F C_F} = \sqrt{\frac{\text{GBP}}{4\pi R_F C_D}} \quad (1)$$

Typical surface-mount resistors have a parasitic capacitance of approximately 0.2 pF that must be deducted from the calculated feedback capacitance value. Bandwidth is calculated by [Equation 2](#):

$$f_{-3\text{dB}} = \sqrt{\frac{\text{GBP}}{2\pi R_F C_D}} \text{ Hz} \quad (2)$$

For even higher transimpedance bandwidth, the high-speed CMOS [OPA355](#) (200-MHz GBW) or the [OPA655](#) (400-MHz GBW) may be used.

7.4 Device Functional Modes

The TLV354x has dual functional modes and is operational when the power-supply voltage is greater than 2.5 V (± 1.25 V). The maximum power-supply voltage for the TLV354x is 5.5 V (± 2.75 V). At +160°C, the protection circuit shuts down the amplifier. Normal operation resumes when the junction temperature cools to below +140°C.

8 Application and Implementation

NOTE

Information in the following applications sections is not part of the TI component specification, and TI does not warrant its accuracy or completeness. TI's customers are responsible for determining suitability of components for their purposes. Customers should validate and test their design implementation to confirm system functionality.

8.1 Application Information

The TLV354x are wide bandwidth, low-noise, rail-to-rail input and output amplifiers. These devices operate from 2.5 V to 5.5 V, are unity-gain stable, and suitable for a wide range of general-purpose applications. The input common-mode voltage range includes both rails, and allows the TLV354x device to be used in any single-supply application. Rail-to-rail input and output swing significantly increases dynamic range, especially in low-supply applications, and makes the device ideal for driving analog-to-digital converters (ADCs).

The TLV354x family of devices features a 200-MHz bandwidth and 150-V/ μ s slew rate with only 7.5 nV/ $\sqrt{\text{Hz}}$ of broadband noise.

8.2 Typical Application

A typical application for an operational amplifier is an inverting amplifier, as shown in [Figure 28](#). An inverting amplifier takes a positive voltage on the input and outputs a signal inverted to the input, making a negative voltage of the same magnitude. In the same manner, the amplifier makes negative input voltages positive on the output. In addition, amplification can be added by selecting the input resistor R_I and the feedback resistor R_F .

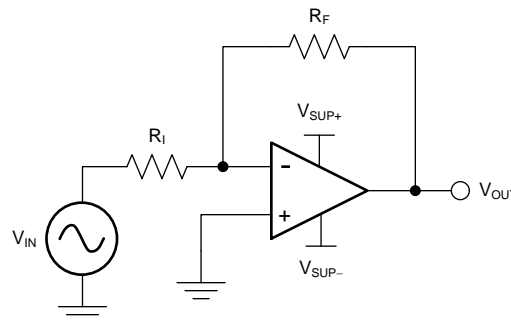

Figure 28. Application Schematic

8.2.1 Design Requirements

The supply voltage must be chosen to be larger than the input voltage range and the desired output range. The limits of the input common-mode range (V_{CM}) and the output voltage swing to the rails (V_O) must be considered. For instance, this application scales a signal of ± 0.5 V (1 V) to ± 1.8 V (3.6 V). Setting the supply at ± 2.5 V is sufficient to accommodate this application.

8.2.2 Detailed Design Procedure

Determine the gain required by the inverting amplifier using [Equation 3](#) and [Equation 4](#):

$$A_V = \frac{V_{OUT}}{V_{IN}} \tag{3}$$

$$A_V = \frac{1.8}{-0.5} = -3.6 \tag{4}$$

Typical Application (continued)

When the desired gain is determined, select a value for R_I or R_F . Selecting a value in the kilo ohm range is desirable for general-purpose applications because the amplifier circuit uses currents in the milliamp range. This milliamp current range ensures the device does not draw too much current. The trade-off is that large resistors (100s of kilo ohms) draw the smallest current but generate the highest noise. Small resistors (100s of ohms) generate low noise but draw high current. This example uses $10\text{ k}\Omega$ for R_I , meaning $36\text{ k}\Omega$ is used for R_F . These values are determined by [Equation 5](#):

$$A_V = -\frac{R_F}{R_I} \quad (5)$$

8.2.3 Application Curve

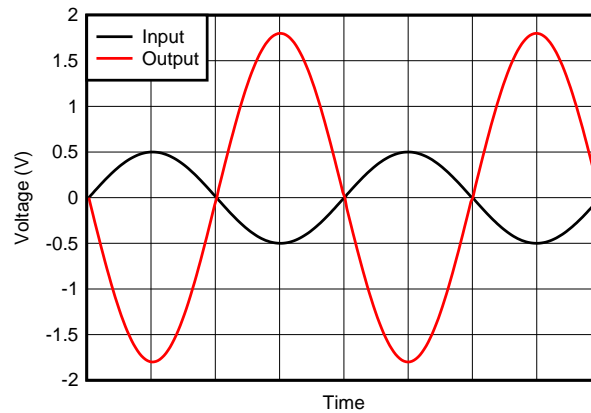
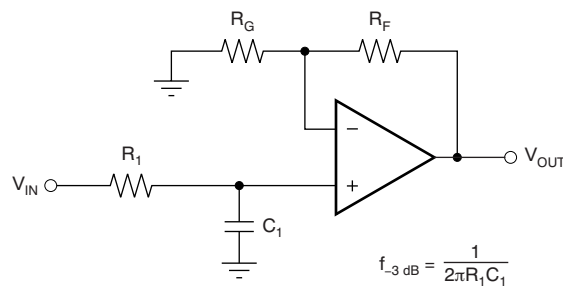

Figure 29. Inverting Amplifier Input and Output

8.3 System Examples

When receiving low-level signals, limiting the bandwidth of the incoming signals into the system is often required. The simplest way to establish this limited bandwidth is to place an RC filter at the noninverting terminal of the amplifier, as shown in [Figure 30](#).



$$\frac{V_{OUT}}{V_{IN}} = \left(1 + \frac{R_F}{R_G}\right) \left(\frac{1}{1 + sR_1C_1}\right)$$

Figure 30. Single-Pole, Low-Pass Filter

System Examples (continued)

If even more attenuation is needed, a multiple pole filter is required. The Sallen-Key filter can be used for this task, as shown in [Figure 31](#). For best results, the amplifier must have a bandwidth that is eight to ten times the filter frequency bandwidth. Failure to follow this guideline can result in phase shift of the amplifier.

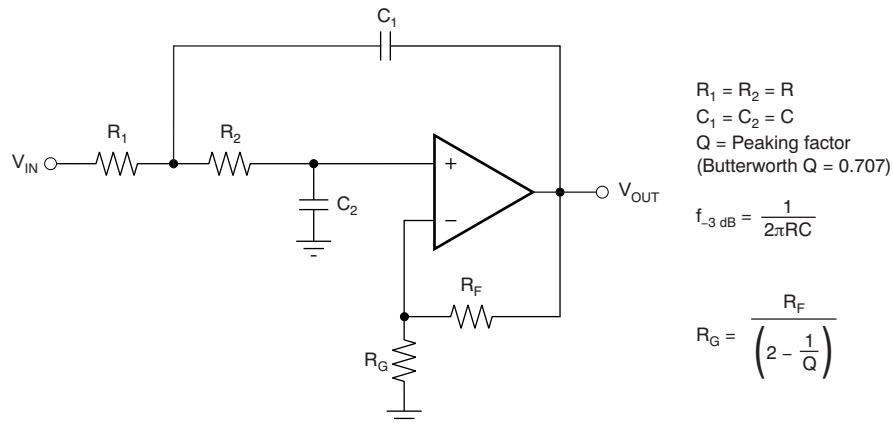

Figure 31. Two-Pole, Low-Pass, Sallen-Key Filter

9 Power Supply Recommendations

The TLV354x family is specified from 2.7 V to 5.5 V (± 1.35 V to ± 2.75 V), although the devices can operate from 2.5 V to 5.5 V (± 1.25 V to ± 2.75 V); many specifications apply from -40°C to $+125^\circ\text{C}$. [Typical Characteristics](#) presents parameters that can exhibit significant variance with regard to operating voltage or temperature.

CAUTION

Supply voltages larger than 7.5 V can permanently damage the device. (See the *Absolute Maximum Ratings* table).

Place 0.1- μF bypass capacitors close to the power-supply pins to reduce errors coupling in from noisy or high-impedance power supplies. For more detailed information on bypass capacitor placement, see [Layout Guidelines](#).

9.1 Input and ESD Protection

The TLV354x family incorporates internal electrostatic discharge (ESD) protection circuits on all pins. In the case of input and output pins, this protection primarily consists of current-steering diodes connected between the input and power-supply pins. These ESD protection diodes also provide in-circuit, input overdrive protection, as long as the current is limited to 10 mA, as stated in the *Absolute Maximum Ratings* table. [Figure 32](#) shows how a series input resistor can be added to the driven input to limit the input current. The added resistor contributes thermal noise at the amplifier input, which must be kept to a minimum in noise-sensitive applications.

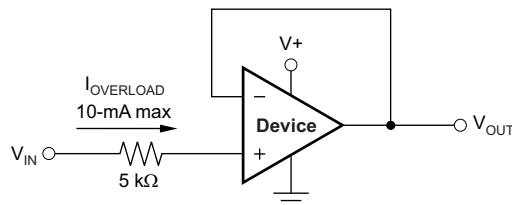

Figure 32. Input Current Protection

10 Layout

10.1 Layout Guidelines

For best operational performance of the device, use good printed circuit board (PCB) layout practices, including:

- Noise propagates into analog circuitry through the power pins of the circuit as a whole and the operational amplifier. Use bypass capacitors to reduce the coupled noise by providing low-impedance power sources local to the analog circuitry.
 - Connect low-ESR, 0.1- μ F ceramic bypass capacitors between each supply pin and ground, placed as close to the device as possible. A single bypass capacitor from V_+ to ground is applicable for single-supply applications.
- Separate grounding for analog and digital portions of the circuitry is one of the simplest and most effective methods of noise suppression. One or more layers on multilayer PCBs are typically devoted to ground planes. A ground plane helps distribute heat and reduces EMI noise pickup. Make sure to physically separate digital and analog grounds, paying attention to the flow of the ground current.
- To reduce parasitic coupling, run the input traces as far away from the supply or output traces as possible. If these traces cannot be kept separate, crossing the sensitive trace perpendicularly is much better than crossing in parallel with the noisy trace.
- Place the external components as close to the device as possible. Keep R_F and R_G close to the inverting input to minimize parasitic capacitance, as shown in Figure 33.
- Keep the length of input traces as short as possible. Always remember that the input traces are the most sensitive part of the circuit.
- Consider a driven, low-impedance guard ring around the critical traces. A guard ring can significantly reduce leakage currents from nearby traces that are at different potentials.

10.2 Layout Example

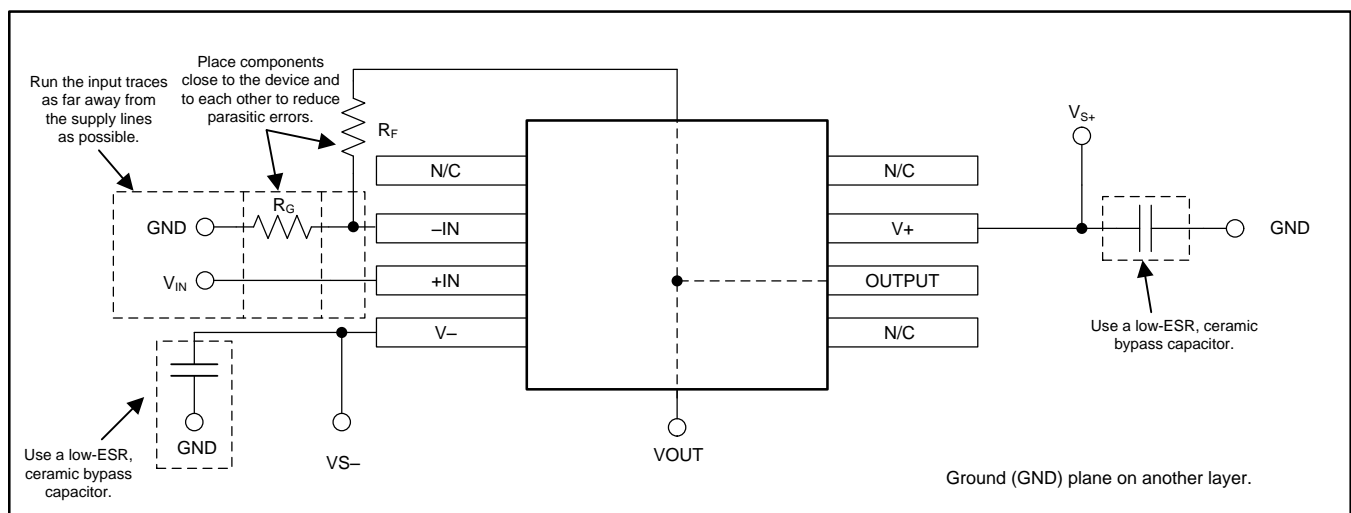
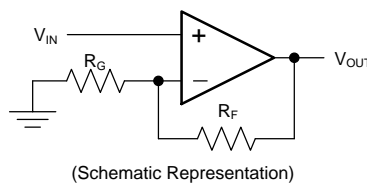

Figure 33. Operational Amplifier Board Layout for Noninverting Configuration

11 Device and Documentation Support

11.1 Documentation Support

11.1.1 Related Documentation

TI recommends using the following reference documents for the TLV354x device. All are available for download at www.ti.com unless otherwise noted.

- [Handbook of Operational Amplifier Applications](#) (SBOA092).
- [Analog Engineer's Pocket Reference](#) (SLYW038).

11.2 Related Links

[Table 1](#) lists quick access links. Categories include technical documents, support and community resources, tools and software, and quick access to sample or buy.

Table 1. Related Links

PARTS	PRODUCT FOLDER	SAMPLE & BUY	TECHNICAL DOCUMENTS	TOOLS & SOFTWARE	SUPPORT & COMMUNITY
TLV3541	Click here	Click here	Click here	Click here	Click here
TLV3542	Click here	Click here	Click here	Click here	Click here
TLV3544	Click here	Click here	Click here	Click here	Click here

11.3 Receiving Notification of Documentation Updates

To receive notification of documentation updates, navigate to the device product folder on ti.com. In the upper right corner, click on Alert me to register and receive a weekly digest of any product information that has changed. For change details, review the revision history included in any revised document.

11.4 Community Resources

The following links connect to TI community resources. Linked contents are provided "AS IS" by the respective contributors. They do not constitute TI specifications and do not necessarily reflect TI's views; see TI's [Terms of Use](#).

TI E2E™ Online Community *TI's Engineer-to-Engineer (E2E) Community*. Created to foster collaboration among engineers. At e2e.ti.com, you can ask questions, share knowledge, explore ideas and help solve problems with fellow engineers.

Design Support *TI's Design Support* Quickly find helpful E2E forums along with design support tools and contact information for technical support.

11.5 Trademarks

E2E is a trademark of Texas Instruments.
All other trademarks are the property of their respective owners.

11.6 Electrostatic Discharge Caution



These devices have limited built-in ESD protection. The leads should be shorted together or the device placed in conductive foam during storage or handling to prevent electrostatic damage to the MOS gates.

11.7 Glossary

[SLYZ022](#) — *TI Glossary*.

This glossary lists and explains terms, acronyms, and definitions.

12 Mechanical, Packaging, and Orderable Information

The following pages include mechanical, packaging, and orderable information. This information is the most current data available for the designated devices. This data is subject to change without notice and revision of this document. For browser-based versions of this data sheet, refer to the left-hand navigation.

PACKAGING INFORMATION

Orderable Device	Status (1)	Package Type	Package Drawing	Pins	Package Qty	Eco Plan (2)	Lead/Ball Finish (6)	MSL Peak Temp (3)	Op Temp (°C)	Device Marking (4/5)	Samples
TLV35411DBVR	ACTIVE	SOT-23	DBV	5	3000	Green (RoHS & no Sb/Br)	CU NIPDAU	Level-2-260C-1 YEAR	-40 to 125	17MD	Samples
TLV35411DBVT	ACTIVE	SOT-23	DBV	5	250	Green (RoHS & no Sb/Br)	CU NIPDAU	Level-2-260C-1 YEAR	-40 to 125	17MD	Samples
TLV35411DR	ACTIVE	SOIC	D	8	2500	Green (RoHS & no Sb/Br)	CU NIPDAU	Level-2-260C-1 YEAR	-40 to 125	TL3541	Samples
TLV35421DGKR	ACTIVE	VSSOP	DGK	8	2500	Green (RoHS & no Sb/Br)	CU NIPDAUAG	Level-2-260C-1 YEAR	-40 to 125	18TE	Samples
TLV35421DGKT	ACTIVE	VSSOP	DGK	8	250	Green (RoHS & no Sb/Br)	CU NIPDAUAG	Level-2-260C-1 YEAR	-40 to 125	18TE	Samples
TLV35421DR	ACTIVE	SOIC	D	8	2500	Green (RoHS & no Sb/Br)	CU NIPDAU	Level-2-260C-1 YEAR	-40 to 125	TL3542	Samples
TLV35441DR	ACTIVE	SOIC	D	14	2500	Green (RoHS & no Sb/Br)	CU NIPDAU	Level-2-260C-1 YEAR	-40 to 125	TLV3544A	Samples
TLV35441PWR	ACTIVE	TSSOP	PW	14	2000	Green (RoHS & no Sb/Br)	CU NIPDAU	Level-2-260C-1 YEAR	-40 to 125	TLV 3544	Samples

(1) The marketing status values are defined as follows:

ACTIVE: Product device recommended for new designs.

LIFEBUY: TI has announced that the device will be discontinued, and a lifetime-buy period is in effect.

NRND: Not recommended for new designs. Device is in production to support existing customers, but TI does not recommend using this part in a new design.

PREVIEW: Device has been announced but is not in production. Samples may or may not be available.

OBSELETE: TI has discontinued the production of the device.

(2) Eco Plan - The planned eco-friendly classification: Pb-Free (RoHS), Pb-Free (RoHS Exempt), or Green (RoHS & no Sb/Br) - please check <http://www.ti.com/productcontent> for the latest availability information and additional product content details.

TBD: The Pb-Free/Green conversion plan has not been defined.

Pb-Free (RoHS): TI's terms "Lead-Free" or "Pb-Free" mean semiconductor products that are compatible with the current RoHS requirements for all 6 substances, including the requirement that lead not exceed 0.1% by weight in homogeneous materials. Where designed to be soldered at high temperatures, TI Pb-Free products are suitable for use in specified lead-free processes.

Pb-Free (RoHS Exempt): This component has a RoHS exemption for either 1) lead-based flip-chip solder bumps used between the die and package, or 2) lead-based die adhesive used between the die and leadframe. The component is otherwise considered Pb-Free (RoHS compatible) as defined above.

Green (RoHS & no Sb/Br): TI defines "Green" to mean Pb-Free (RoHS compatible), and free of Bromine (Br) and Antimony (Sb) based flame retardants (Br or Sb do not exceed 0.1% by weight in homogeneous material)

(3) MSL, Peak Temp. - The Moisture Sensitivity Level rating according to the JEDEC industry standard classifications, and peak solder temperature.

(4) There may be additional marking, which relates to the logo, the lot trace code information, or the environmental category on the device.

(5) Multiple Device Markings will be inside parentheses. Only one Device Marking contained in parentheses and separated by a "~" will appear on a device. If a line is indented then it is a continuation of the previous line and the two combined represent the entire Device Marking for that device.

(6) Lead/Ball Finish - Orderable Devices may have multiple material finish options. Finish options are separated by a vertical ruled line. Lead/Ball Finish values may wrap to two lines if the finish value exceeds the maximum column width.

Important Information and Disclaimer:The information provided on this page represents TI's knowledge and belief as of the date that it is provided. TI bases its knowledge and belief on information provided by third parties, and makes no representation or warranty as to the accuracy of such information. Efforts are underway to better integrate information from third parties. TI has taken and continues to take reasonable steps to provide representative and accurate information but may not have conducted destructive testing or chemical analysis on incoming materials and chemicals. TI and TI suppliers consider certain information to be proprietary, and thus CAS numbers and other limited information may not be available for release.

In no event shall TI's liability arising out of such information exceed the total purchase price of the TI part(s) at issue in this document sold by TI to Customer on an annual basis.

TAPE AND REEL INFORMATION



QUADRANT ASSIGNMENTS FOR PIN 1 ORIENTATION IN TAPE



*All dimensions are nominal

Device	Package Type	Package Drawing	Pins	SPQ	Reel Diameter (mm)	Reel Width W1 (mm)	A0 (mm)	B0 (mm)	K0 (mm)	P1 (mm)	W (mm)	Pin1 Quadrant
TLV3541IDBVR	SOT-23	DBV	5	3000	178.0	9.0	3.23	3.17	1.37	4.0	8.0	Q3
TLV3541IDBVT	SOT-23	DBV	5	250	178.0	9.0	3.3	3.2	1.4	4.0	8.0	Q3
TLV3541IDR	SOIC	D	8	2500	330.0	12.4	6.4	5.2	2.1	8.0	12.0	Q1
TLV3542IDGKR	VSSOP	DGK	8	2500	330.0	12.4	5.3	3.4	1.4	8.0	12.0	Q1
TLV3542IDGKT	VSSOP	DGK	8	250	330.0	12.4	5.3	3.4	1.4	8.0	12.0	Q1
TLV3542IDR	SOIC	D	8	2500	330.0	12.4	6.4	5.2	2.1	8.0	12.0	Q1
TLV3544IDR	SOIC	D	14	2500	330.0	16.4	6.5	9.0	2.1	8.0	16.0	Q1
TLV3544IPWR	TSSOP	PW	14	2000	330.0	12.4	6.9	5.6	1.6	8.0	12.0	Q1

TAPE AND REEL BOX DIMENSIONS

*All dimensions are nominal

Device	Package Type	Package Drawing	Pins	SPQ	Length (mm)	Width (mm)	Height (mm)
TLV3541IDBVR	SOT-23	DBV	5	3000	180.0	180.0	18.0
TLV3541IDBVT	SOT-23	DBV	5	250	180.0	180.0	18.0
TLV3541IDR	SOIC	D	8	2500	367.0	367.0	35.0
TLV3542IDGKR	VSSOP	DGK	8	2500	366.0	364.0	50.0
TLV3542IDGKT	VSSOP	DGK	8	250	366.0	364.0	50.0
TLV3542IDR	SOIC	D	8	2500	367.0	367.0	35.0
TLV3544IDR	SOIC	D	14	2500	367.0	367.0	38.0
TLV3544IPWR	TSSOP	PW	14	2000	367.0	367.0	35.0

D (R-PDSO-G14)

PLASTIC SMALL OUTLINE

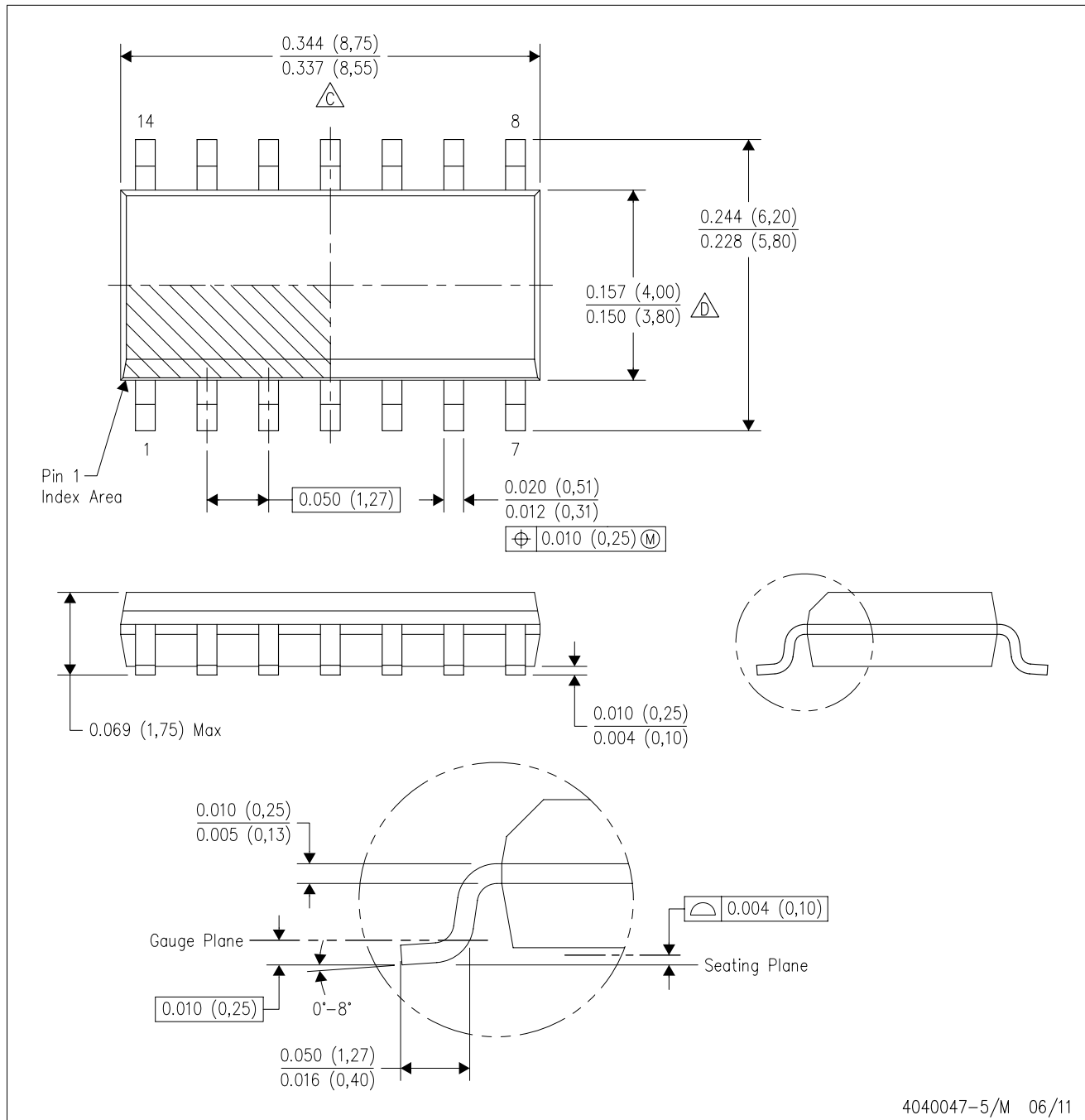

- NOTES:
- A. All linear dimensions are in inches (millimeters).
 - B. This drawing is subject to change without notice.
 - C. Body length does not include mold flash, protrusions, or gate burrs. Mold flash, protrusions, or gate burrs shall not exceed 0.006 (0,15) each side.
 - D. Body width does not include interlead flash. Interlead flash shall not exceed 0.017 (0,43) each side.
 - E. Reference JEDEC MS-012 variation AB.

D (R-PDSO-G14)

PLASTIC SMALL OUTLINE



4211283-3/E 08/12

- NOTES:
- A. All linear dimensions are in millimeters.
 - B. This drawing is subject to change without notice.
 - C. Publication IPC-7351 is recommended for alternate designs.
 - D. Laser cutting apertures with trapezoidal walls and also rounding corners will offer better paste release. Customers should contact their board assembly site for stencil design recommendations. Refer to IPC-7525 for other stencil recommendations.
 - E. Customers should contact their board fabrication site for solder mask tolerances between and around signal pads.

PW (R-PDSO-G14)

PLASTIC SMALL OUTLINE

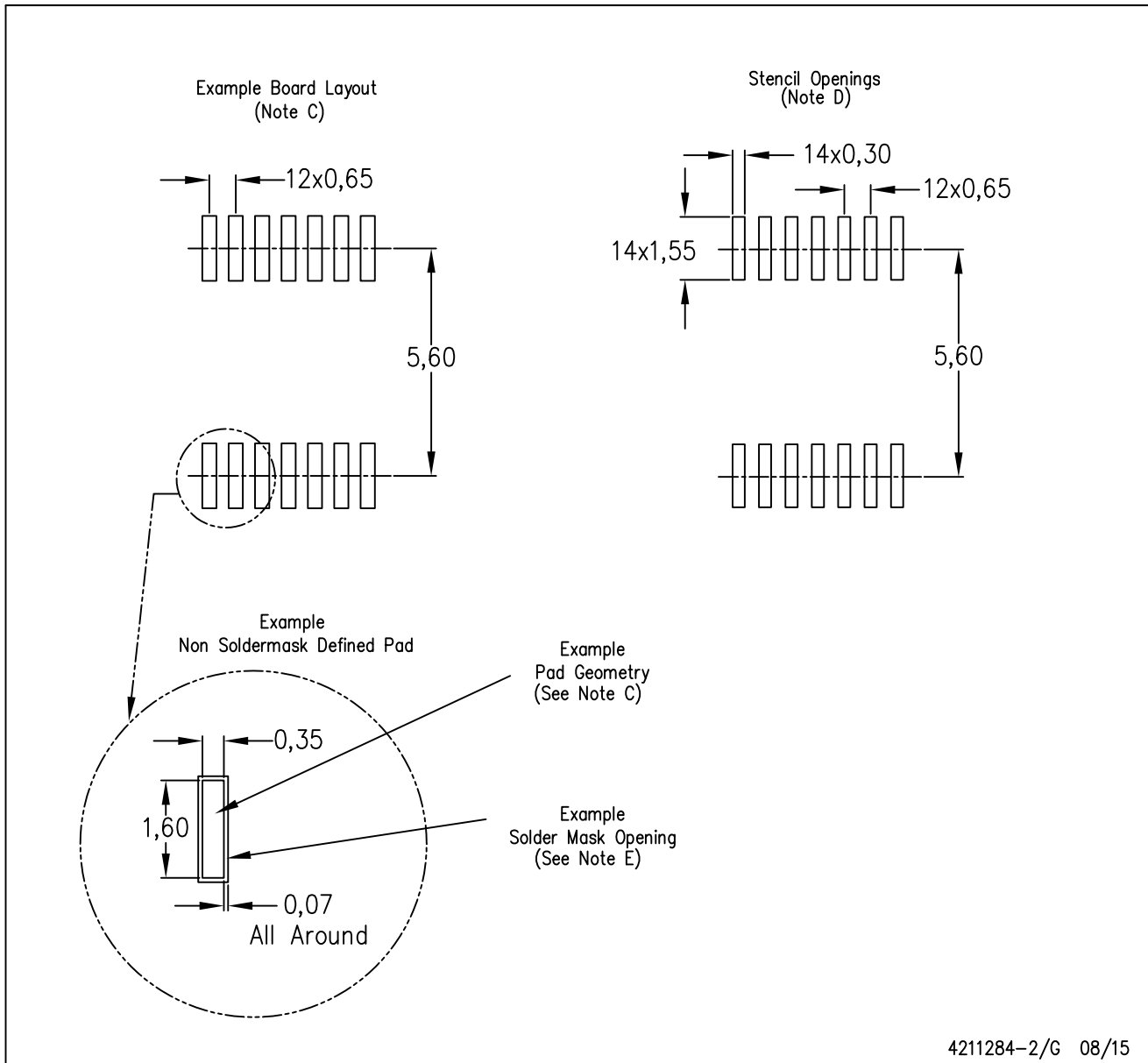

- NOTES:
- All linear dimensions are in millimeters.
 - This drawing is subject to change without notice.
 - Publication IPC-7351 is recommended for alternate designs.
 - Laser cutting apertures with trapezoidal walls and also rounding corners will offer better paste release. Customers should contact their board assembly site for stencil design recommendations. Refer to IPC-7525 for other stencil recommendations.
 - Customers should contact their board fabrication site for solder mask tolerances between and around signal pads.



D0008A

PACKAGE OUTLINE

SOIC - 1.75 mm max height

SMALL OUTLINE INTEGRATED CIRCUIT



4214825/C 02/2019

NOTES:

1. Linear dimensions are in inches [millimeters]. Dimensions in parenthesis are for reference only. Controlling dimensions are in inches. Dimensioning and tolerancing per ASME Y14.5M.
2. This drawing is subject to change without notice.
3. This dimension does not include mold flash, protrusions, or gate burrs. Mold flash, protrusions, or gate burrs shall not exceed .006 [0.15] per side.
4. This dimension does not include interlead flash.
5. Reference JEDEC registration MS-012, variation AA.

EXAMPLE BOARD LAYOUT

D0008A

SOIC - 1.75 mm max height

SMALL OUTLINE INTEGRATED CIRCUIT



LAND PATTERN EXAMPLE
 EXPOSED METAL SHOWN
 SCALE:8X



SOLDER MASK DETAILS

4214825/C 02/2019

NOTES: (continued)

- 6. Publication IPC-7351 may have alternate designs.
- 7. Solder mask tolerances between and around signal pads can vary based on board fabrication site.

EXAMPLE STENCIL DESIGN

D0008A

SOIC - 1.75 mm max height

SMALL OUTLINE INTEGRATED CIRCUIT



SOLDER PASTE EXAMPLE
BASED ON .005 INCH [0.125 MM] THICK STENCIL
SCALE:8X

4214825/C 02/2019

NOTES: (continued)

8. Laser cutting apertures with trapezoidal walls and rounded corners may offer better paste release. IPC-7525 may have alternate design recommendations.
9. Board assembly site may have different recommendations for stencil design.

EXAMPLE BOARD LAYOUT

DBV0005A

SOT-23 - 1.45 mm max height

SMALL OUTLINE TRANSISTOR



LAND PATTERN EXAMPLE
EXPOSED METAL SHOWN
SCALE:15X



SOLDER MASK DETAILS

4214839/D 11/2018

NOTES: (continued)

- Publication IPC-7351 may have alternate designs.
- Solder mask tolerances between and around signal pads can vary based on board fabrication site.

EXAMPLE STENCIL DESIGN

DBV0005A

SOT-23 - 1.45 mm max height

SMALL OUTLINE TRANSISTOR



SOLDER PASTE EXAMPLE
BASED ON 0.125 mm THICK STENCIL
SCALE:15X

4214839/D 11/2018

NOTES: (continued)

7. Laser cutting apertures with trapezoidal walls and rounded corners may offer better paste release. IPC-7525 may have alternate design recommendations.
8. Board assembly site may have different recommendations for stencil design.

DGK (S-PDSO-G8)

PLASTIC SMALL-OUTLINE PACKAGE

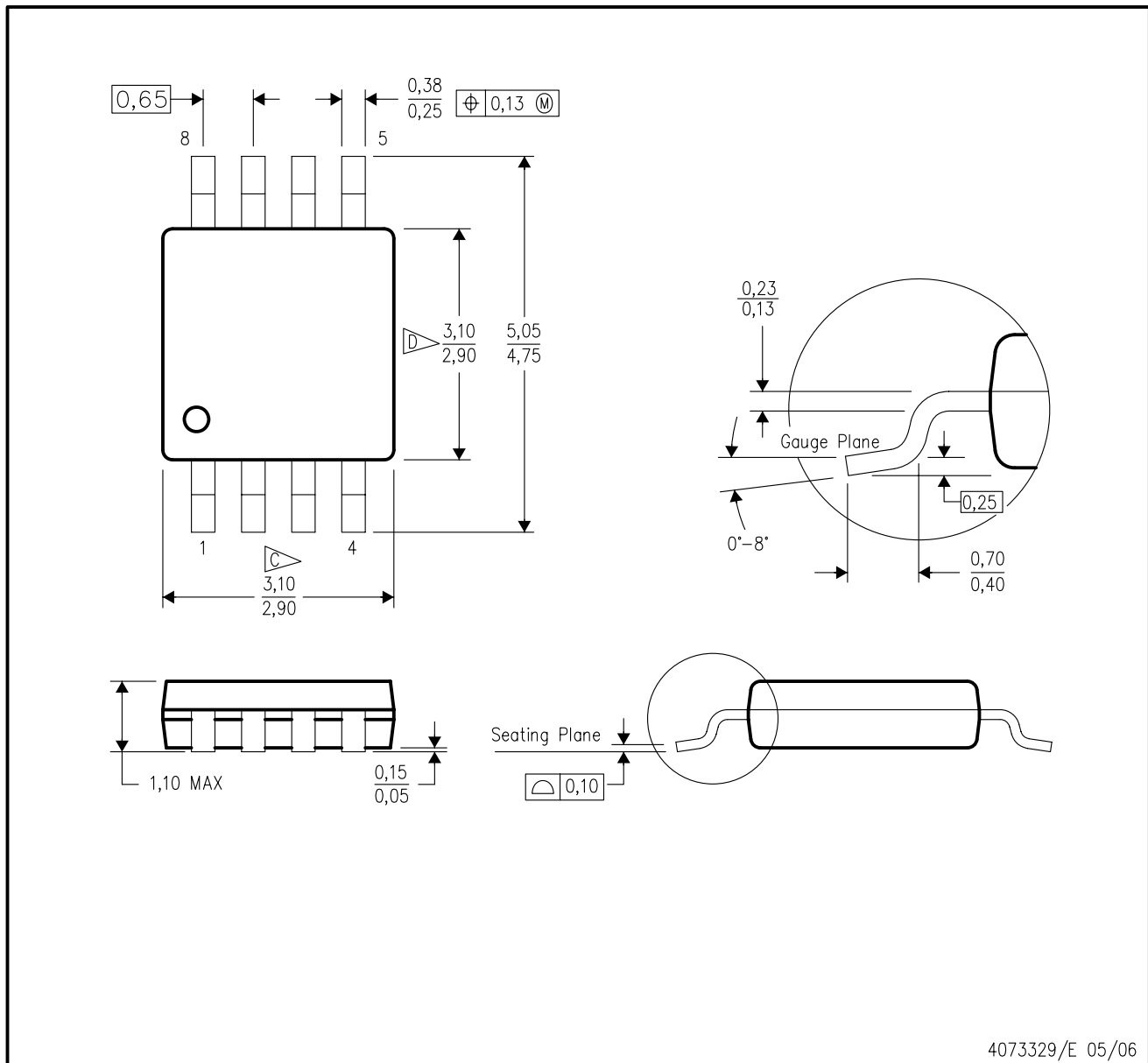

- NOTES:
- A. All linear dimensions are in millimeters.
 - B. This drawing is subject to change without notice.
 - C. Body length does not include mold flash, protrusions, or gate burrs. Mold flash, protrusions, or gate burrs shall not exceed 0.15 per end.
 - D. Body width does not include interlead flash. Interlead flash shall not exceed 0.50 per side.
 - E. Falls within JEDEC MO-187 variation AA, except interlead flash.



- NOTES:
- A. All linear dimensions are in millimeters.
 - B. This drawing is subject to change without notice.
 - C. Publication IPC-7351 is recommended for alternate designs.
 - D. Laser cutting apertures with trapezoidal walls and also rounding corners will offer better paste release. Customers should contact their board assembly site for stencil design recommendations. Refer to IPC-7525 for other stencil recommendations.
 - E. Customers should contact their board fabrication site for solder mask tolerances between and around signal pads.

IMPORTANT NOTICE AND DISCLAIMER

TI PROVIDES TECHNICAL AND RELIABILITY DATA (INCLUDING DATASHEETS), DESIGN RESOURCES (INCLUDING REFERENCE DESIGNS), APPLICATION OR OTHER DESIGN ADVICE, WEB TOOLS, SAFETY INFORMATION, AND OTHER RESOURCES "AS IS" AND WITH ALL FAULTS, AND DISCLAIMS ALL WARRANTIES, EXPRESS AND IMPLIED, INCLUDING WITHOUT LIMITATION ANY IMPLIED WARRANTIES OF MERCHANTABILITY, FITNESS FOR A PARTICULAR PURPOSE OR NON-INFRINGEMENT OF THIRD PARTY INTELLECTUAL PROPERTY RIGHTS.

These resources are intended for skilled developers designing with TI products. You are solely responsible for (1) selecting the appropriate TI products for your application, (2) designing, validating and testing your application, and (3) ensuring your application meets applicable standards, and any other safety, security, or other requirements. These resources are subject to change without notice. TI grants you permission to use these resources only for development of an application that uses the TI products described in the resource. Other reproduction and display of these resources is prohibited. No license is granted to any other TI intellectual property right or to any third party intellectual property right. TI disclaims responsibility for, and you will fully indemnify TI and its representatives against, any claims, damages, costs, losses, and liabilities arising out of your use of these resources.

TI's products are provided subject to TI's Terms of Sale (www.ti.com/legal/termsofsale.html) or other applicable terms available either on ti.com or provided in conjunction with such TI products. TI's provision of these resources does not expand or otherwise alter TI's applicable warranties or warranty disclaimers for TI products.

Mailing Address: Texas Instruments, Post Office Box 655303, Dallas, Texas 75265
Copyright © 2019, Texas Instruments Incorporated

Looking for pricing, stock, or lifecycle information?

Click below to explore more details on WIN SOURCE:

 [View TLV3542IDGKT on WIN SOURCE](#)

 [Texas Instruments](#) Information

Optimize Your Supply Chain with WIN SOURCE Solutions

-  Global Sourcing Solution
-  Obsolete Management
-  Cost Control Management
-  Shortage Management
-  Alternative Solution
-  Excess Inventory Management