



**THE DATASHEET OF  
TPS564201DDCT**



# TPS564201 4.5-V to 17-V Input, 4-A Synchronous Step-Down Voltage Regulator in SOT-23

## 1 Features

- TPS564201 4-A Converter Integrated 50-m $\Omega$  and 22-m $\Omega$  FETs
- D-CAP2™ Mode Control with Fast Transient Response
- Input Voltage Range: 4.5 V to 17 V
- Output Voltage Range: 0.76 V to 7 V
- Pulse Skip Mode
- 560-kHz Switching Frequency
- Low Shutdown Current Less than 5  $\mu$ A
- 1.6% Feedback Voltage Accuracy (25°C)
- Startup from Pre-Biased Output Voltage
- Cycle-by-Cycle Overcurrent Limit
- Hiccup-mode Overcurrent Protection
- Non-Latch UVP and TSD Protections
- Fixed Soft Start: 1.0 ms
- Create a Custom Design Using the TPS564201 With the [WEBENCH® Power Designer](#)

## 2 Applications

- Digital TV Power Supply
- High Definition Blu-ray™ Disc Players
- Networking Home Terminal
- Digital Set Top Box (STB)
- Surveillance

## 3 Description

The TPS564201 is a simple, easy-to-use, 4-A synchronous step-down converter in SOT-23 package.

The device is optimized to operate with minimum external component count and also optimized to achieve low standby current.

These switch mode power supply (SMPS) devices employ D-CAP2 mode control providing a fast transient response and supporting both low-equivalent series resistance (ESR) output capacitors such as specialty polymer and ultra-low ESR ceramic capacitors with no external compensation components.

The TPS564201 operates in pulse skip mode, maintaining high efficiency during light load operation. The TPS564201 is available in a 6-pin 1.6-mm  $\times$  2.9-mm SOT (DDC) package, and specified from a  $-40^{\circ}\text{C}$  to  $125^{\circ}\text{C}$  junction temperature.

### Device Information<sup>(1)</sup>

| PART NUMBER | PACKAGE | BODY SIZE (NOM)          |
|-------------|---------|--------------------------|
| TPS564201   | DDC (6) | 1.60 mm $\times$ 2.90 mm |

(1) For all available packages, see the orderable addendum at the end of the data sheet.

### Simplified Schematic

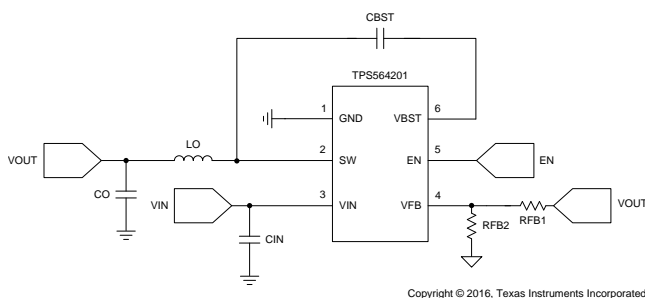

### TPS564201 Efficiency

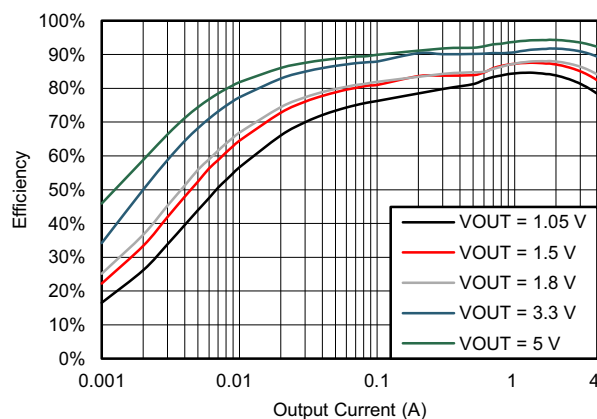

## Table of Contents

|  |           |  |           |
|--|-----------|--|-----------|
| <b>1 Features</b> .....                        | <b>1</b>  | 7.4 Device Functional Modes.....                                 | <b>11</b> |
| <b>2 Applications</b> .....                    | <b>1</b>  | <b>8 Application and Implementation</b> .....                    | <b>12</b> |
| <b>3 Description</b> .....                     | <b>1</b>  | 8.1 Application Information.....                                 | <b>12</b> |
| <b>4 Revision History</b> .....                | <b>2</b>  | 8.2 Typical Application .....                                    | <b>12</b> |
| <b>5 Pin Configuration and Functions</b> ..... | <b>3</b>  | <b>9 Power Supply Recommendations</b> .....                      | <b>18</b> |
| <b>6 Specifications</b> .....                  | <b>4</b>  | <b>10 Layout</b> .....   | <b>19</b> |
| 6.1 Absolute Maximum Ratings .....             | <b>4</b>  | 10.1 Layout Guidelines .....                                     | <b>19</b> |
| 6.2 ESD Ratings.....                           | <b>4</b>  | 10.2 Layout Example .....  | <b>19</b> |
| 6.3 Recommended Operating Conditions.....      | <b>4</b>  | <b>11 Device and Documentation Support</b> .....                 | <b>20</b> |
| 6.4 Thermal Information .....                  | <b>4</b>  | 11.1 Development Support .....                                   | <b>20</b> |
| 6.5 Electrical Characteristics.....            | <b>5</b>  | 11.2 Receiving Notification of Documentation Updates             | <b>20</b> |
| 6.6 Typical Characteristics .....              | <b>6</b>  | 11.3 Community Resources.....                                    | <b>20</b> |
| <b>7 Detailed Description</b> .....            | <b>9</b>  | 11.4 Trademarks .....  | <b>20</b> |
| 7.1 Overview .....                             | <b>9</b>  | 11.5 Electrostatic Discharge Caution.....                        | <b>20</b> |
| 7.2 Functional Block Diagram .....             | <b>9</b>  | 11.6 Glossary .....  | <b>20</b> |
| 7.3 Feature Description.....                   | <b>10</b> | <b>12 Mechanical, Packaging, and Orderable Information</b> ..... | <b>21</b> |

## 4 Revision History

NOTE: Page numbers for previous revisions may differ from page numbers in the current version.

| <b>Changes from Revision A (May 2016) to Revision B</b>  | <b>Page</b> |
|--|-------------|
| • Added WEBENCH® Designer link to Features .....   | <b>1</b>    |
| • Changed $V_{FBTH}$ spec MIN from 739 to 745, TYP from 759 to 760, and MAX from 779 to 775..... | <b>5</b>    |
| • Changed equation <a href="#">Equation 2</a> .....  | <b>13</b>   |
| • Added <a href="#">Custom Design With WEBENCH® Tools</a> .....                                  | <b>20</b>   |

| <b>Changes from Original (May 2016) to Revision A</b> | <b>Page</b> |
|---|-------------|
| • Full specification release .....                    | <b>1</b>    |

## 5 Pin Configuration and Functions

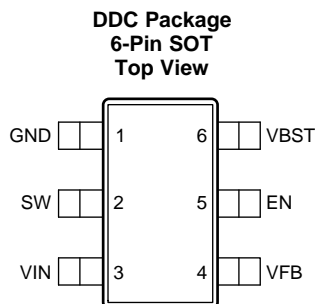

### Pin Functions

| PIN  |     | I/O | DESCRIPTION   |
|------|-----|-----|---|
| NAME | NO. |     |   |
| GND  | 1   | —   | Ground pin Source terminal of low-side power NFET as well as the ground terminal for controller circuit. Connect sensitive VFB to this GND at a single point. |
| SW   | 2   | O   | Switch node connection between high-side NFET and low-side NFET.  |
| VIN  | 3   | I   | Input voltage supply pin. The drain terminal of high-side power NFET.   |
| VFB  | 4   | I   | Converter feedback input. Connect to output voltage with feedback resistor divider.   |
| EN   | 5   | I   | Enable input control. Active high and must be pulled up to enable the device.   |
| VBST | 6   | O   | Supply input for the high-side NFET gate drive circuit. Connect 0.1 $\mu$ F capacitor between VBST and SW pins.   |

## 6 Specifications

### 6.1 Absolute Maximum Ratings

 over operating free-air temperature range (unless otherwise noted)<sup>(1)</sup>

|  |                        | MIN  | MAX | UNIT |
|--|------------------------|------|-----|------|
| Input voltage                                  | VIN, EN                | −0.3 | 19  | V    |
|  | VBST                   | −0.3 | 25  | V    |
|  | VBST (10 ns transient) | −0.3 | 27  | V    |
|  | VBST (vs SW)           | −0.3 | 6.5 | V    |
|  | VFB                    | −0.3 | 6.5 | V    |
|  | SW                     | −2   | 19  | V    |
|  | SW (10 ns transient)   | −3.5 | 21  | V    |
| Operating junction temperature, T <sub>J</sub> |                        | −40  | 150 | °C   |
| Storage temperature, T <sub>stg</sub>          |                        | −55  | 150 | °C   |

- (1) Stresses beyond those listed under *Absolute Maximum Ratings* may cause permanent damage to the device. These are stress ratings only, which do not imply functional operation of the device at these or any other conditions beyond those indicated under *Recommended Operating Conditions*. Exposure to absolute-maximum-rated conditions for extended periods may affect device reliability.

### 6.2 ESD Ratings

|  |  | VALUE | UNIT |
|--|--|-------|------|
| V <sub>(ESD)</sub> Electrostatic discharge | Human-body model (HBM), per ANSI/ESDA/JEDEC JS-001 <sup>(1)</sup>              | ±4000 | V    |
|  | Charged-device model (CDM), per JEDEC specification JESD22-C101 <sup>(2)</sup> | ±1500 |      |

- (1) JEDEC document JEP155 states that 500-V HBM allows safe manufacturing with a standard ESD control process.  
 (2) JEDEC document JEP157 states that 250-V CDM allows safe manufacturing with a standard ESD control process.

### 6.3 Recommended Operating Conditions

over operating free-air temperature range (unless otherwise noted)

|                 |                                | MIN                    | NOM  | MAX | UNIT |
|-----------------|--------------------------------|------------------------|------|-----|------|
| V <sub>IN</sub> | Supply input voltage range     | 4.5                    |      | 17  | V    |
| V <sub>I</sub>  | Input voltage range            | VBST                   |      | 23  | V    |
|                 |                                | VBST (10 ns transient) |      | 26  |      |
|                 |                                | VBST (vs SW)           |      | 6.0 |      |
|                 |                                | EN                     | −0.1 | 17  |      |
|                 |                                | VFB                    | −0.1 | 5.5 |      |
|                 |                                | SW                     | −1.8 | 17  |      |
|                 |                                | SW (10 ns transient)   | −3.5 | 20  |      |
| T <sub>J</sub>  | Operating junction temperature | −40                    |      | 125 | °C   |

### 6.4 Thermal Information

| THERMAL METRIC <sup>(1)</sup> |  | TPS564201 | UNIT |
|-------------------------------|--|-----------|------|
|                               |  | DDC (SOT) |      |
|                               |  | 6 PINS    |      |
| R <sub>θJA</sub>              | Junction-to-ambient thermal resistance       | 86.3      | °C/W |
| R <sub>θJC(top)</sub>         | Junction-to-case (top) thermal resistance    | 39.4      | °C/W |
| R <sub>θJB</sub>              | Junction-to-board thermal resistance         | 13.3      | °C/W |
| ψ <sub>JT</sub>               | Junction-to-top characterization parameter   | 1.8       | °C/W |
| ψ <sub>JB</sub>               | Junction-to-board characterization parameter | 13.3      | °C/W |

- (1) For more information about traditional and new thermal metrics, see the *Semiconductor and IC Package Thermal Metrics* application report, [SPRA953](#).

## 6.5 Electrical Characteristics

 $T_J = -40^{\circ}\text{C}$  to  $125^{\circ}\text{C}$ ,  $V_{IN} = 12\text{ V}$  (unless otherwise noted)

| PARAMETER   |   | TEST CONDITIONS  | MIN       | TYP  | MAX       | UNIT               |
|---|---|--|-----------|------|-----------|--------------------|
| <b>SUPPLY CURRENT</b>                                       |   |  |           |      |           |                    |
| $I_{VIN}$   | Operating – non-switching supply current  | $V_{IN}$ current, $EN = 5\text{ V}$ , $V_{FB} = 1\text{ V}$            | TPS564201 | 400  | 510       | $\mu\text{A}$      |
| $I_{VINS\text{DN}}$   | Shutdown supply current                   | $V_{IN}$ current, $EN = 0\text{ V}$                                    |           | 0.9  | 5         | $\mu\text{A}$      |
| <b>LOGIC THRESHOLD</b>                                      |   |  |           |      |           |                    |
| $V_{ENH}$   | EN high-level input voltage               | EN   | 1.6       |      |           | V                  |
| $V_{ENL}$   | EN low-level input voltage                | EN   |           |      | 0.8       | V                  |
| $R_{EN}$  | EN pin resistance to GND                  | $V_{EN} = 12\text{ V}$   | 225       | 425  | 900       | $\text{k}\Omega$   |
| <b><math>V_{FB}</math> VOLTAGE AND DISCHARGE RESISTANCE</b> |   |  |           |      |           |                    |
| $V_{FBTH}$  | $V_{FB}$ threshold voltage                | $V_O = 1.05\text{ V}$ , continuous mode operation                      | 745       | 760  | 775       | mV                 |
| $I_{VFB}$   | $V_{FB}$ input current                    | $V_{FB} = 0.8\text{ V}$  |           | 0    | $\pm 0.1$ | $\mu\text{A}$      |
| <b>MOSFET</b>   |   |  |           |      |           |                    |
| $R_{DS(\text{on})h}$  | High-side switch resistance               | $T_A = 25^{\circ}\text{C}$ , $V_{BST} - SW = 5.5\text{ V}$             |           | 50   |           | $\text{m}\Omega$   |
| $R_{DS(\text{on})l}$  | Low-side switch resistance                | $T_A = 25^{\circ}\text{C}$   |           | 22   |           | $\text{m}\Omega$   |
| <b>CURRENT LIMIT</b>  |   |  |           |      |           |                    |
| $I_{oc\text{l}}$  | Current limit <sup>(1)</sup>              | DC current, $V_{OUT} = 1.05\text{ V}$ , $L_1 = 1.5\text{ }\mu\text{H}$ | 4.2       | 6    | 7.7       | A                  |
| <b>THERMAL SHUTDOWN</b>                                     |   |  |           |      |           |                    |
| $T_{SDN}$   | Thermal shutdown threshold <sup>(1)</sup> | Shutdown temperature   |           | 172  |           | $^{\circ}\text{C}$ |
|   |   | Hysteresis   |           | 38   |           |                    |
| <b>ON-TIME TIMER CONTROL</b>                                |   |  |           |      |           |                    |
| $t_{OFF(\text{MIN})}$                                       | Minimum off time                          | $V_{FB} = 0.68\text{ V}$   |           | 220  | 280       | ns                 |
| <b>SOFT START</b>   |   |  |           |      |           |                    |
| $t_{SS}$  | Soft-start time                           | Internal soft-start time   |           | 1.0  |           | ms                 |
| <b>FREQUENCY</b>  |   |  |           |      |           |                    |
| $F_{sw}$  | Switching frequency                       | $V_{IN} = 12\text{ V}$ , $V_O = 1.05\text{ V}$ , FCCM mode             |           | 560  |           | kHz                |
| <b>OUTPUT UNDERVOLTAGE AND OVERVOLTAGE PROTECTION</b>       |   |  |           |      |           |                    |
| $V_{UVP}$   | Output UVP threshold                      | Hiccup detect ( $H > L$ )  |           | 65%  |           |                    |
| $T_{HICCUP\_WAIT}$  | Hiccup on time                            |  |           | 1.9  |           | ms                 |
| $T_{HICCUP\_RE}$  | Hiccup time before restart                |  |           | 15.5 |           | ms                 |
| <b>UVLO</b>   |   |  |           |      |           |                    |
| UVLO  | UVLO threshold                            | Wake up VIN voltage  |           | 4.0  | 4.3       | V                  |
|   |   | Shutdown VIN voltage   | 3.3       | 3.6  |           |                    |
|   |   | Hysteresis VIN voltage <sup>(1)</sup>                                  |           | 0.4  |           |                    |

(1) Not production tested.

## 6.6 Typical Characteristics

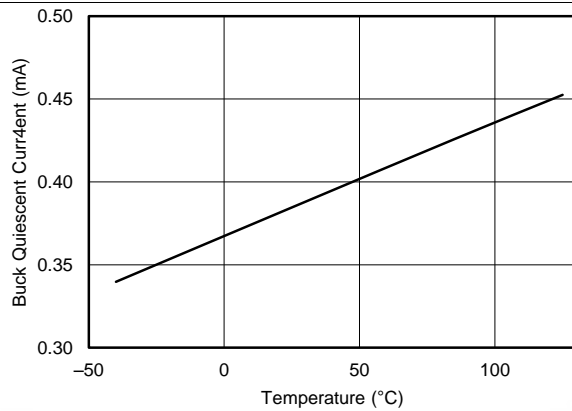
 $V_{IN} = 12\text{ V}$  (unless otherwise noted)

**Figure 1. TPS56420 Supply Current vs Junction Temperature**

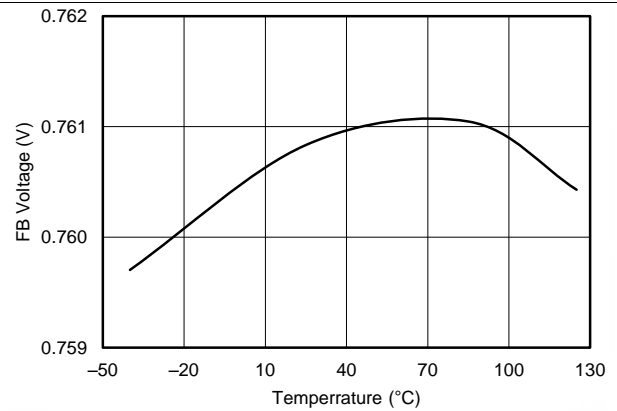

**Figure 2. VFB Voltage vs Junction Temperature**

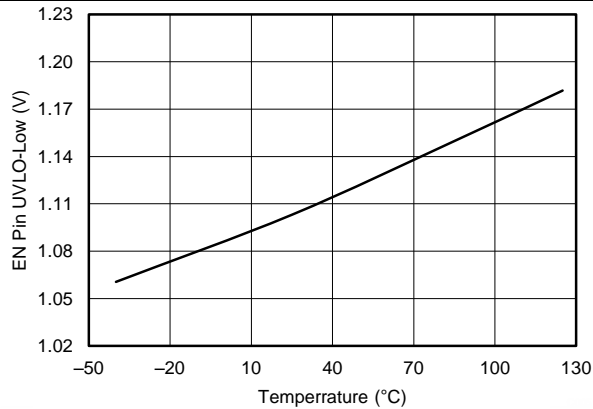

**Figure 3. EN Pin UVLO Low Voltage vs Junction Temperature**

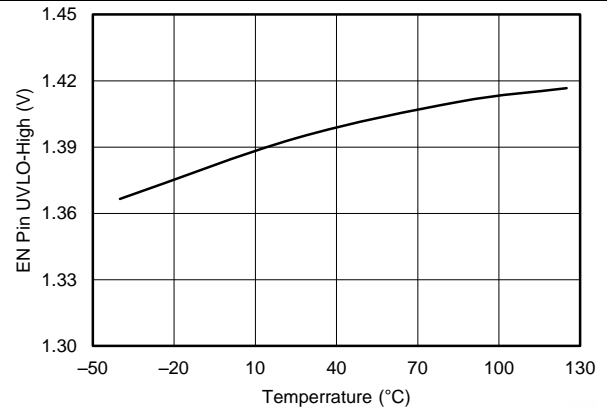

**Figure 4. TPS564201 EN Pin UVLO High Voltage vs Junction Temperature**

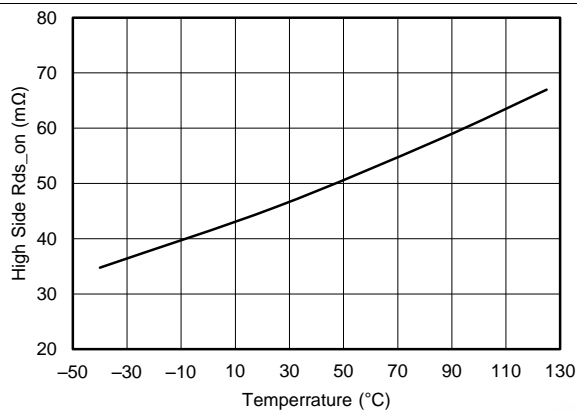

**Figure 5. TPS564201 High-Side  $R_{ds-On}$  vs Junction Temperature**

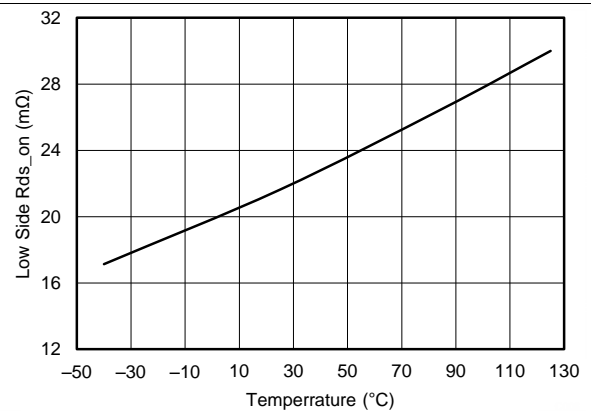

**Figure 6. Low-Side  $R_{ds-On}$  vs Junction Temperature**

Typical Characteristics (continued)

V<sub>IN</sub> = 12 V (unless otherwise noted)

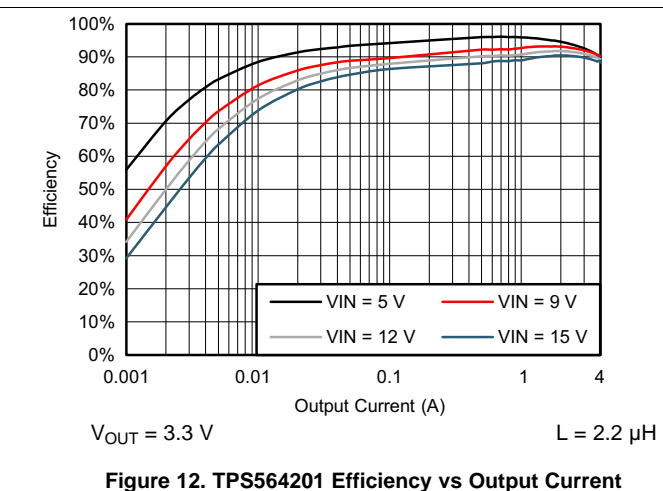
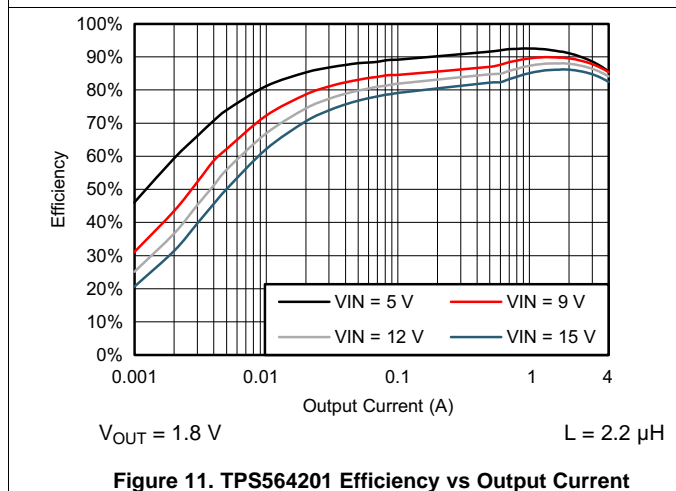
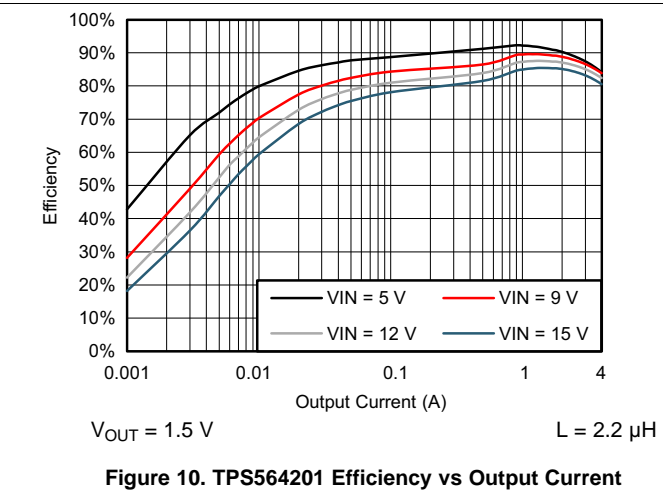
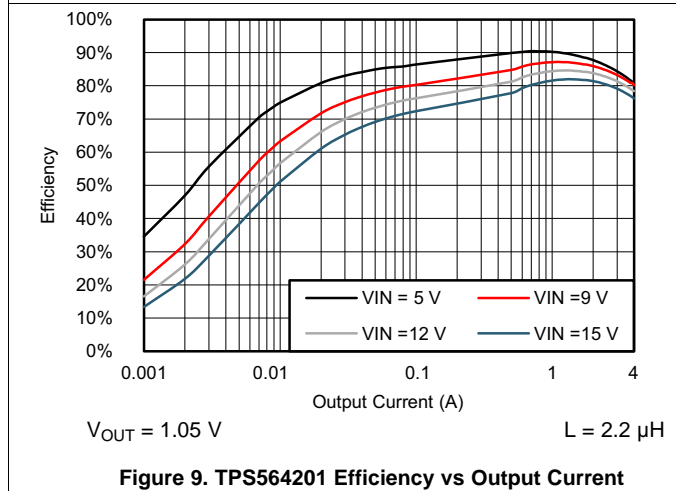
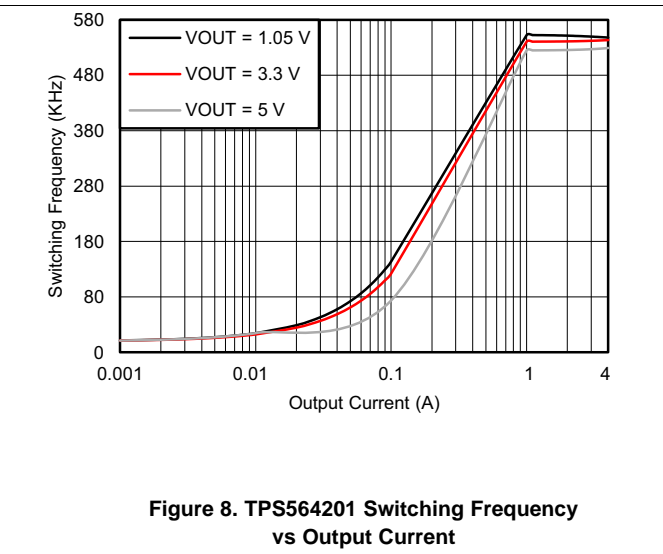
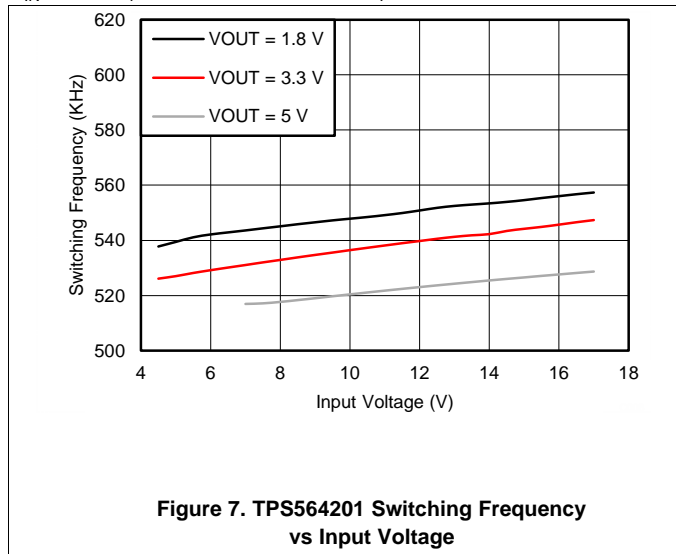



## 7 Detailed Description

### 7.1 Overview

The TPS564201 is a 4-A synchronous step-down converter. The proprietary D-CAP2™ mode control supports low ESR output capacitors such as specialty polymer capacitors and multi-layer ceramic capacitors without complex external compensation circuits. The fast transient response of D-CAP2™ mode control can reduce the output capacitance required to meet a specific level of performance.

### 7.2 Functional Block Diagram

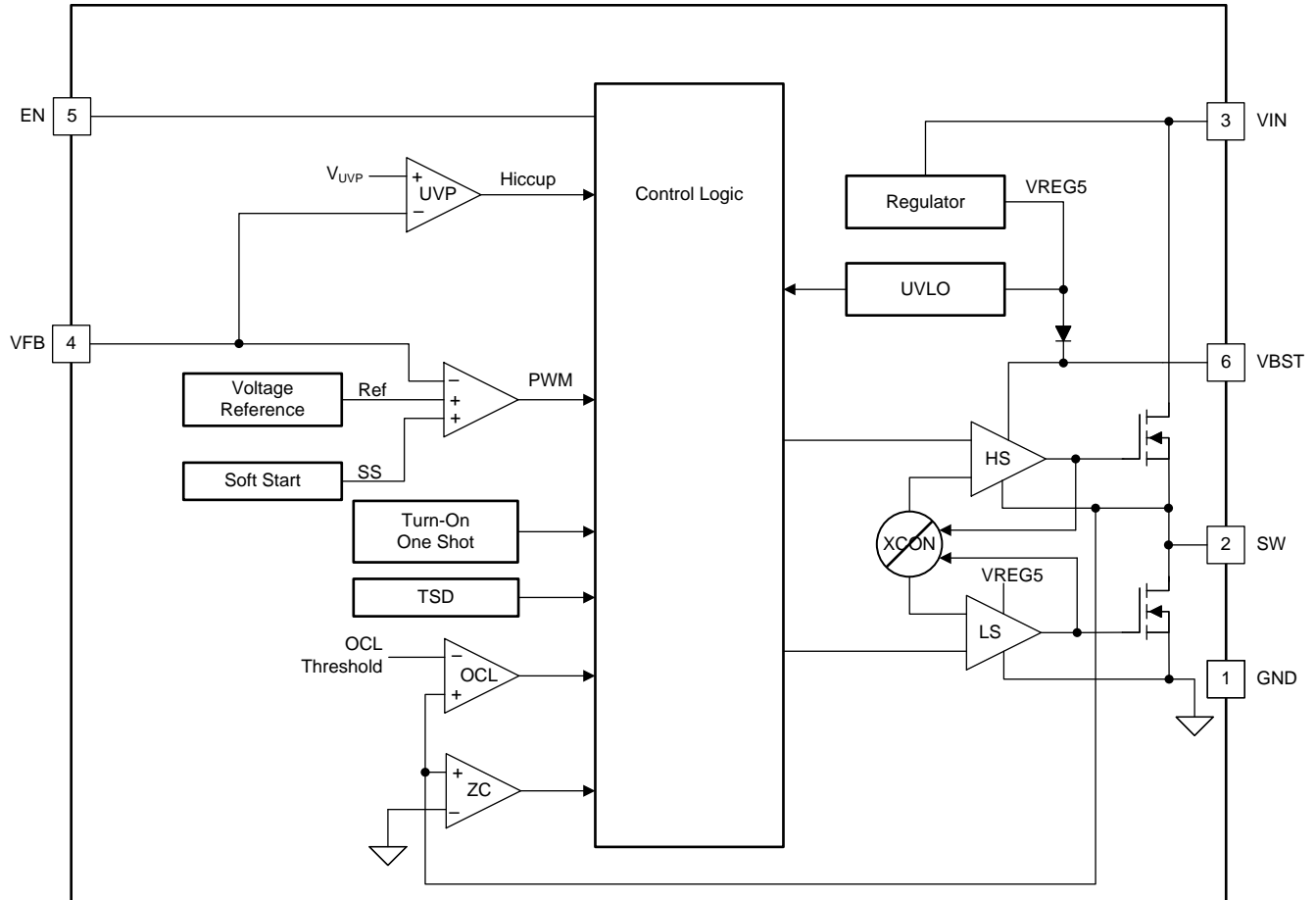

Copyright © 2016, Texas Instruments Incorporated

## 7.3 Feature Description

### 7.3.1 Adaptive On-Time Control and PWM Operation

The main control loop of the TPS564201 is adaptive on-time pulse width modulation (PWM) controller that supports a proprietary D-CAP2™ mode control. The D-CAP2™ mode control combines adaptive on-time control with an internal compensation circuit for pseudo-fixed frequency and low external component count configuration with both low-ESR and ceramic output capacitors. It is stable even with virtually no ripple at the output.

At the beginning of each cycle, the high-side MOSFET is turned on. This MOSFET is turned off after internal one-shot timer expires. This one shot duration is set inversely proportional to the converter input voltage,  $V_{IN}$ , and proportional to the output voltage  $V_O$ , to maintain a pseudo-fixed frequency over the input voltage range, hence it is called adaptive on-time control. The one-shot timer is reset and the high-side MOSFET is turned on again when the feedback voltage falls below the reference voltage. An internal ramp is added to reference voltage to simulate output ripple, eliminating the need for ESR induced output ripple from D-CAP2™ mode control.

### 7.3.2 Pulse Skip Mode

The TPS564201 is designed with Advanced Eco-mode™ to maintain high light load efficiency. As the output current decreases from heavy load condition, the inductor current is also reduced and eventually comes to point that its rippled valley touches zero level, which is the boundary between continuous conduction and discontinuous conduction modes. The rectifying MOSFET is turned off when the zero inductor current is detected. As the load current further decreases the converter runs into discontinuous conduction mode. The on-time is kept almost the same as it was in the continuous conduction mode so that it takes longer time to discharge the output capacitor with smaller load current to the level of the reference voltage. This makes the switching frequency lower, proportional to the load current, and keeps the light load efficiency high. The transition point to the light load operation  $I_{OUT(LL)}$  current can be calculated in [Equation 1](#).

$$I_{OUT(LL)} = \frac{1}{2 \times L \times f_{SW}} \times \frac{(V_{IN} - V_{OUT}) \times V_{OUT}}{V_{IN}} \quad (1)$$

### 7.3.3 Soft Start and Pre-Biased Soft Start

The TPS564201 has an internal 1.0-ms soft-start. When the EN pin becomes high, the internal soft-start function begins ramping up the reference voltage to the PWM comparator.

If the output capacitor is pre-biased at startup, the device initiates switching and starts ramping up only after the internal reference voltage becomes greater than the feedback voltage  $V_{FB}$ . This scheme ensures that the converter ramps up smoothly into regulation point.

## Feature Description (continued)

### 7.3.4 Current Protection

The output over-current limit (OCL) is implemented using a cycle-by-cycle valley detect control circuit. The switch current is monitored during the OFF state by measuring the low-side FET drain to source voltage. This voltage is proportional to the switch current. To improve accuracy, the voltage sensing is temperature compensated.

During the on time of the high-side FET switch, the switch current increases at a linear rate determined by  $V_{IN}$ ,  $V_{OUT}$ , the on-time and the output inductor value. During the on time of the low-side FET switch, this current decreases linearly. The average value of the switch current is the load current  $I_{out}$ . If the monitored current is above the OCL level, the converter maintains low-side FET on and delays the creation of a new set pulse, even the voltage feedback loop requires one, until the current level becomes OCL level or lower. In subsequent switching cycles, the on-time is set to a fixed value and the current is monitored in the same manner.

There are some important considerations for this type of over-current protection. The load current is higher than the over-current threshold by one half of the peak-to-peak inductor ripple current. Also, when the current is being limited, the output voltage tends to fall as the demanded load current may be higher than the current available from the converter. This may cause the output voltage to fall. When the VFB voltage falls below the UVP threshold voltage, the UVP comparator detects it. And then, the device shuts down after the UVP delay time (typically 24  $\mu$ s) and re-starts after the hiccup time (typically 15.5 ms).

When the over current condition is removed, the output voltage returns to the regulated value.

### 7.3.5 Undervoltage Lockout (UVLO) Protection

UVLO protection monitors the internal regulator voltage. When the voltage is lower than UVLO threshold voltage, the device is shut off. This protection is non-latching.

### 7.3.6 Thermal Shutdown

The device monitors the temperature of itself. If the temperature exceeds the threshold value (typically 172°C), the device is shut off. This is a non-latch protection.

## 7.4 Device Functional Modes

### 7.4.1 Normal Operation

When the input voltage is above the UVLO threshold and the EN voltage is above the enable threshold, the TPS564201 operates in the normal switching mode. Normal continuous conduction mode (CCM) occurs when the minimum switch current is above 0 A. In CCM, the TPS564201 operates at a quasi-fixed frequency of 560 kHz.

### 7.4.2 Eco-mode™ Operation

When the TPS564201 is in the normal CCM operating mode and the switch current falls to 0A, the TPS564201 begins operating in pulse skipping eco-mode. Each switching cycle is followed by a period of energy saving sleep time. The sleep time ends when the VFB voltage falls below the eco-mode threshold voltage. As the output current decreases, the perceived time between switching pulses increases.

### 7.4.3 Standby Operation

When the TPS564201 is operating in either normal CCM or Eco-mode™, it may be placed in standby by asserting the EN pin low.

## 8 Application and Implementation

### NOTE

Information in the following applications sections is not part of the TI component specification, and TI does not warrant its accuracy or completeness. TI's customers are responsible for determining suitability of components for their purposes. Customers should validate and test their design implementation to confirm system functionality.

### 8.1 Application Information

The device is a typical step-down DC-DC converter for converting a higher dc voltage to a lower dc voltage with a maximum available output current of 4 A. The following design procedure can be used to select component values for the TPS564201. Alternately, the WEBENCH<sup>®</sup> software may be used to generate a complete design. The WEBENCH software uses an iterative design procedure and accesses a comprehensive database of components when generating a design. This section presents a simplified discussion of the design process.

### 8.2 Typical Application

The application schematic in Figure 14 shows the TPS564201 4.5-V to 17-V input, 1.05-V output converter design meeting the requirements for 4-A output. This circuit is available as the evaluation module (EVM). The sections provide the design procedure.

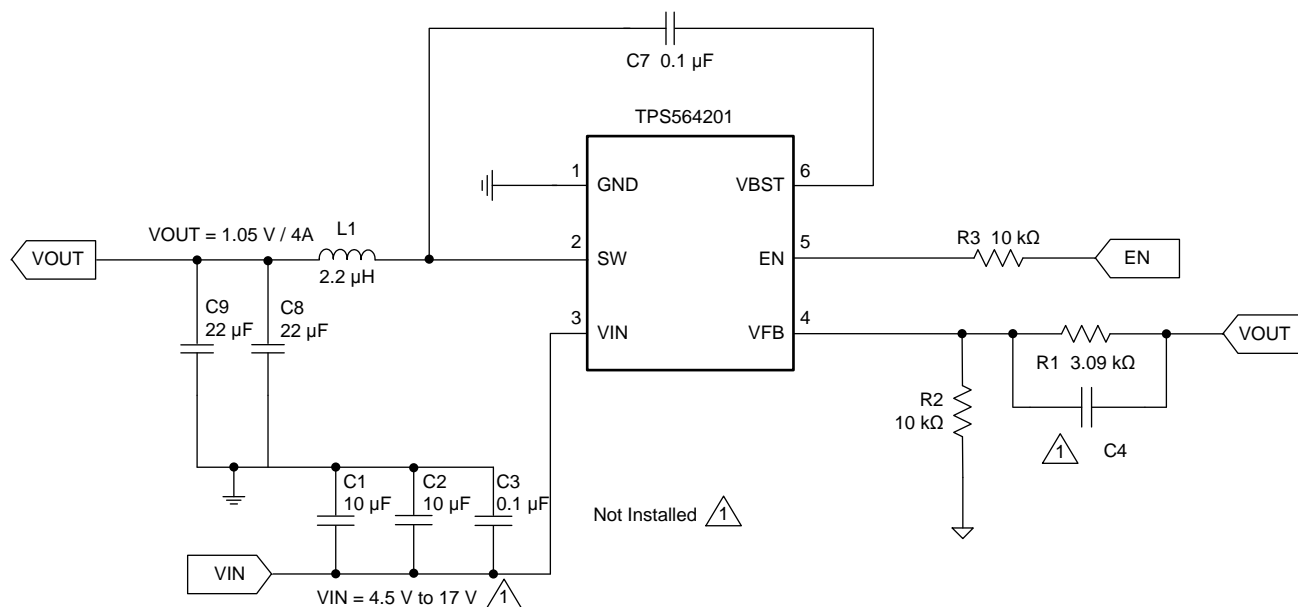

Copyright © 2016, Texas Instruments Incorporated

Figure 14. TPS564201 1.05-V, 4-A Reference Design

## Typical Application (continued)

### 8.2.1 Design Requirements

Table 1 shows the design parameters for this application.

**Table 1. Design Parameters**

| PARAMETER                         | EXAMPLE VALUE              |
|-----------------------------------|----------------------------|
| Input voltage range               | 4.5 to 17 V                |
| Output voltage                    | 1.05 V                     |
| Transient response, 2-A load step | $\Delta V_{out} = \pm 5\%$ |
| Input ripple voltage              | 400 mV                     |
| Output ripple voltage             | 30 mV                      |
| Output current rating             | 4 A                        |
| Operating frequency               | 560 kHz                    |

### 8.2.2 Detailed Design Procedure

#### 8.2.2.1 Custom Design With WEBENCH® Tools

Click [here](#) to create a custom design using the TPS564201 device with the WEBENCH® Power Designer.

1. Start by entering the input voltage ( $V_{IN}$ ), output voltage ( $V_{OUT}$ ), and output current ( $I_{OUT}$ ) requirements.
2. Optimize the design for key parameters such as efficiency, footprint, and cost using the optimizer dial.
3. Compare the generated design with other possible solutions from Texas Instruments.

The WEBENCH Power Designer provides a customized schematic along with a list of materials with real-time pricing and component availability.

In most cases, these actions are available:

- Run electrical simulations to see important waveforms and circuit performance
- Run thermal simulations to understand board thermal performance
- Export customized schematic and layout into popular CAD formats
- Print PDF reports for the design, and share the design with colleagues

Get more information about WEBENCH tools at [www.ti.com/WBENCH](http://www.ti.com/WBENCH).

#### 8.2.2.2 Output Voltage Resistors Selection

The output voltage is set with a resistor divider from the output node to the VFB pin. TI recommends to use 1% tolerance or better divider resistors. Start by using to calculate  $V_{OUT}$ .

To improve efficiency at very light loads consider using larger value resistors. However, using too high of resistance causes the circuit to be more susceptible to noise; and, voltage errors from the VFB input current will be more noticeable.

$$V_{OUT} = 0.760 \times \left( 1 + \frac{R1}{R2} \right) \quad (2)$$

#### 8.2.2.3 Output Filter Selection

The LC filter used as the output filter has double pole at:

$$f_p = \frac{1}{2\pi\sqrt{L_{OUT} \times C_{OUT}}} \quad (3)$$

At low frequencies, the overall loop gain is set by the output set-point resistor divider network and the internal gain of the device. The low frequency phase is 180°. At the output filter pole frequency, the gain rolls off at a –40 dB per decade rate and the phase drops rapidly. D-CAP2 introduces a high frequency zero that reduces the gain roll off to –20 dB per decade and increases the phase to 90° one decade above the zero frequency. The inductor and capacitor for the output filter must be selected so that the double pole of Equation 3 is located below the high frequency zero but close enough that the phase boost provided by the high frequency zero provides adequate phase margin for a stable circuit. To meet this requirement use the values recommended in Table 2.

**Table 2. Recommended Component Values**

| OUTPUT VOLTAGE (V) | R1 (kΩ) | R2 (kΩ) | L1 (μH) |     |     | C8 + C9 (μF) |
|--------------------|---------|---------|---------|-----|-----|--------------|
|                    |         |         | MIN     | TYP | MAX |              |
| 1                  | 3.09    | 10.0    | 1.5     | 2.2 | 4.7 | 20 to 68     |
| 1.05               | 3.74    | 10.0    | 1.5     | 2.2 | 4.7 | 20 to 68     |
| 1.2                | 5.76    | 10.0    | 1.5     | 2.2 | 4.7 | 20 to 68     |
| 1.5                | 9.53    | 10.0    | 1.5     | 2.2 | 4.7 | 20 to 68     |
| 1.8                | 13.7    | 10.0    | 1.5     | 2.2 | 4.7 | 20 to 68     |
| 2.5                | 22.6    | 10.0    | 2.2     | 2.2 | 4.7 | 20 to 68     |
| 3.3                | 33.2    | 10.0    | 2.2     | 2.2 | 4.7 | 20 to 68     |
| 5                  | 54.9    | 10.0    | 3.3     | 3.3 | 4.7 | 20 to 68     |
| 6.5                | 75      | 10.0    | 3.3     | 3.3 | 4.7 | 20 to 68     |

The inductor peak-to-peak ripple current, peak current and RMS current are calculated using Equation 4, Equation 5, and Equation 6. The inductor saturation current rating must be greater than the calculated peak current and the RMS or heating current rating must be greater than the calculated RMS current.

Use 560 kHz for  $f_{SW}$ . Make sure the chosen inductor is rated for the peak current of Equation 5 and the RMS current of Equation 7.

$$I_{P-P} = \frac{V_{OUT}}{V_{IN(MAX)}} \times \frac{V_{IN(MAX)} - V_{OUT}}{L_O \times f_{SW}} \quad (4)$$

$$I_{PEAK} = I_O + \frac{I_{P-P}}{2} \quad (5)$$

$$I_{LO(RMS)} = \sqrt{I_O^2 + \frac{1}{12} I_{P-P}^2} \quad (6)$$

For this design example, the calculated peak current is 4.4 A and the calculated RMS current is 4 A. The inductor used is a WE 74431122 with a peak current rating of 13 A and an RMS current rating of 9 A.

The capacitor value and ESR determines the amount of output voltage ripple. The TPS564201 is intended for use with ceramic or other low ESR capacitors. Recommended values range from 20 μF to 68 μF. Use Equation 7 to determine the required RMS current rating for the output capacitor.

$$I_{CO(RMS)} = \frac{V_{OUT} \times (V_{IN} - V_{OUT})}{\sqrt{12} \times V_{IN} \times L_O \times f_{SW}} \quad (7)$$

For this design two TDK C3216X5R0J226M 22-μF output capacitors are used. The typical ESR is 2 mΩ each. The calculated RMS current is 0.286 A and each output capacitor is rated for 4 A.

#### 8.2.2.4 Input Capacitor Selection

The TPS564201 requires an input decoupling capacitor and a bulk capacitor is needed depending on the application. TI recommends a ceramic capacitor over 10 μF for the decoupling capacitor. An additional 0.1-μF capacitor (C3) from pin 3 to ground is optional to provide additional high frequency filtering. The capacitor voltage rating needs to be greater than the maximum input voltage.

### **8.2.2.5 Bootstrap Capacitor Selection**

A 0.1- $\mu$ F ceramic capacitor must be connected between the VBST to SW pin for proper operation. TI recommends to use a ceramic capacitor.

### 8.2.3 Application Curves

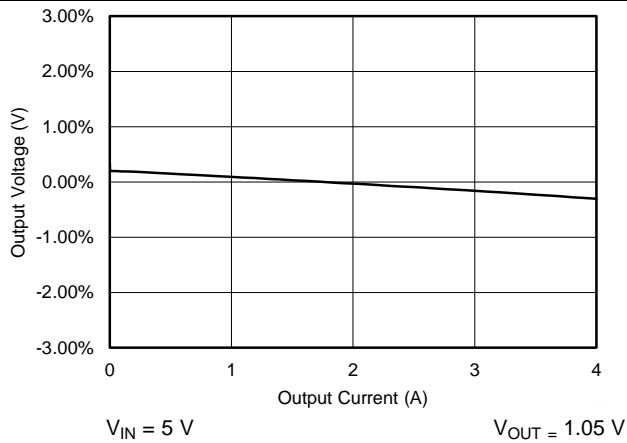

Figure 15. Load Regulation,  $V_{IN} = 5\text{ V}$

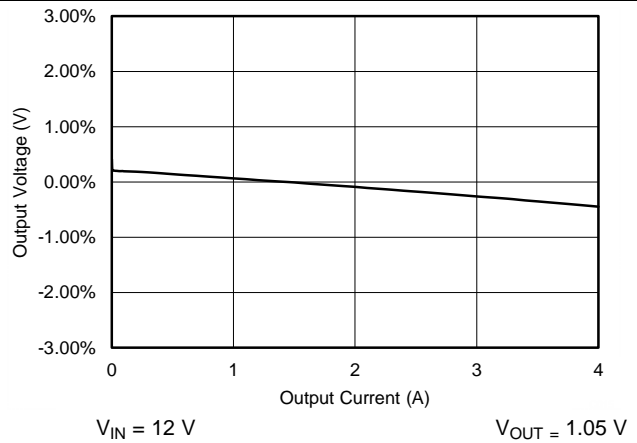

Figure 16. Load Regulation,  $V_{IN} = 12\text{ V}$

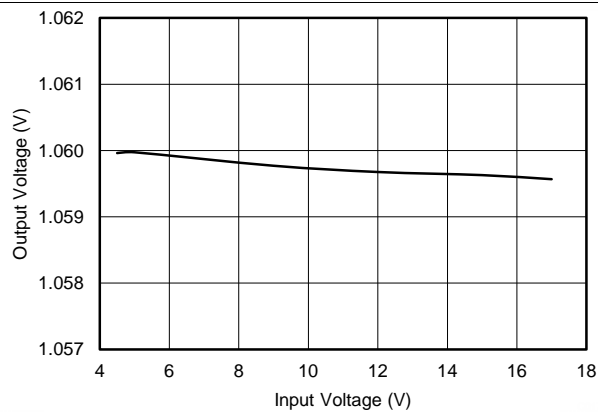

Figure 17. Line Regulation

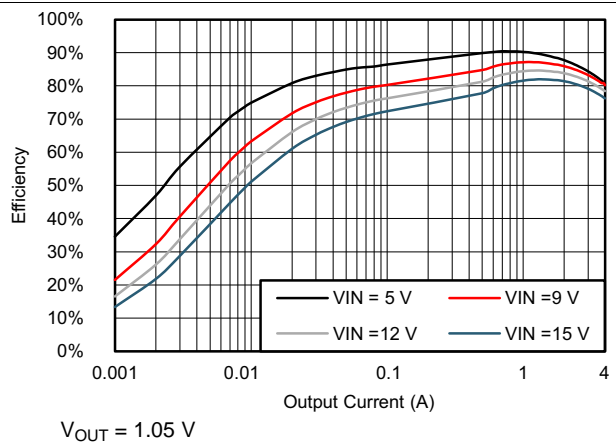

Figure 18. Efficiency vs Output Current

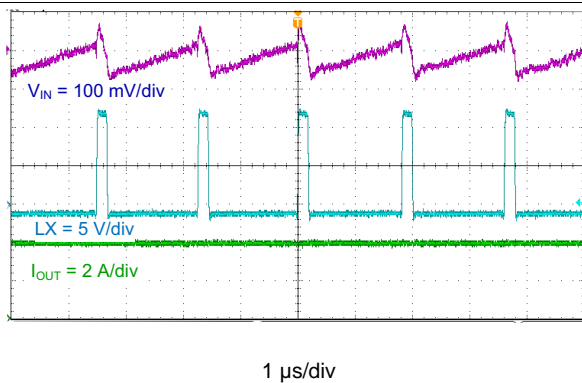

Figure 19. TPS564201 Input Voltage Ripple

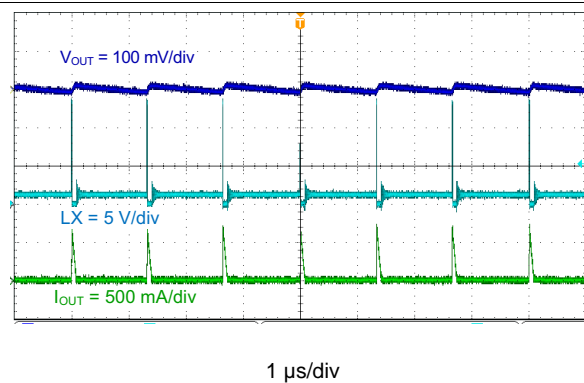
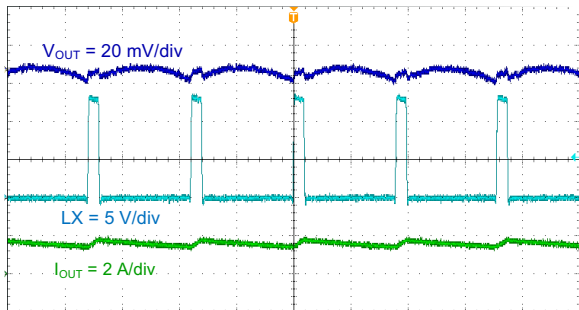
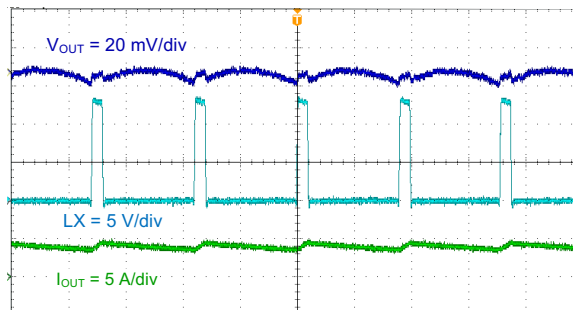

Figure 20. TPS564201 Output Voltage Ripple, No Load



1 μs/div

Figure 21. TPS564201 Output Voltage Ripple, I<sub>OUT</sub> 2 A



1 μs/div

Figure 22. TPS564201 Output Voltage Ripple, I<sub>OUT</sub> 4 A

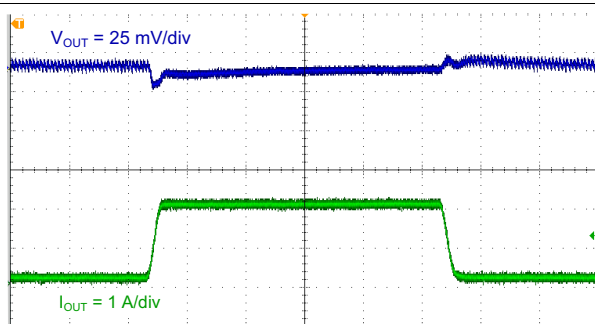

100 μs/div

Figure 23. TPS564201 Transient Response 0.1 to 2 A

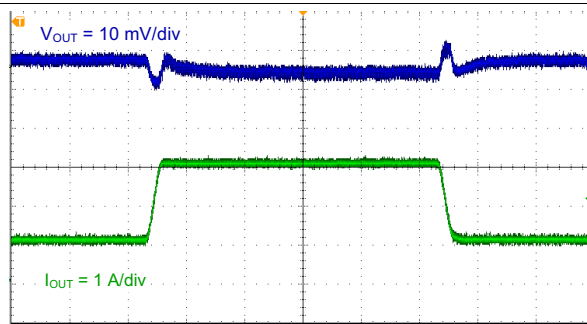

100 μs/div

Figure 24. TPS564201 Transient Response, 1 to 3 A

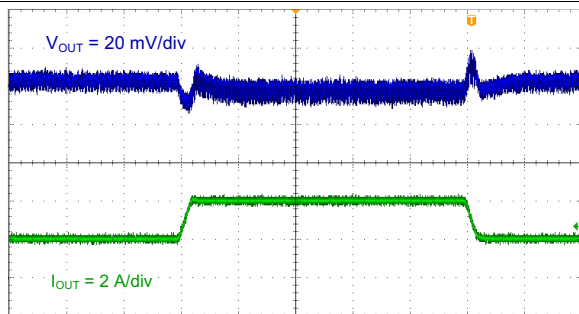

100 μs/div

Figure 25. TPS564201 Transient Response, 2 to 4 A

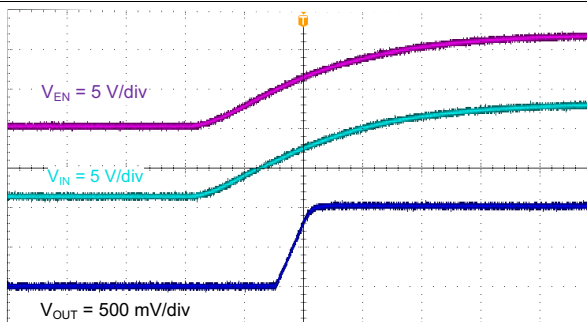

2 ms/div

Figure 26. TPS564201 Startup Relative to V<sub>IN</sub>

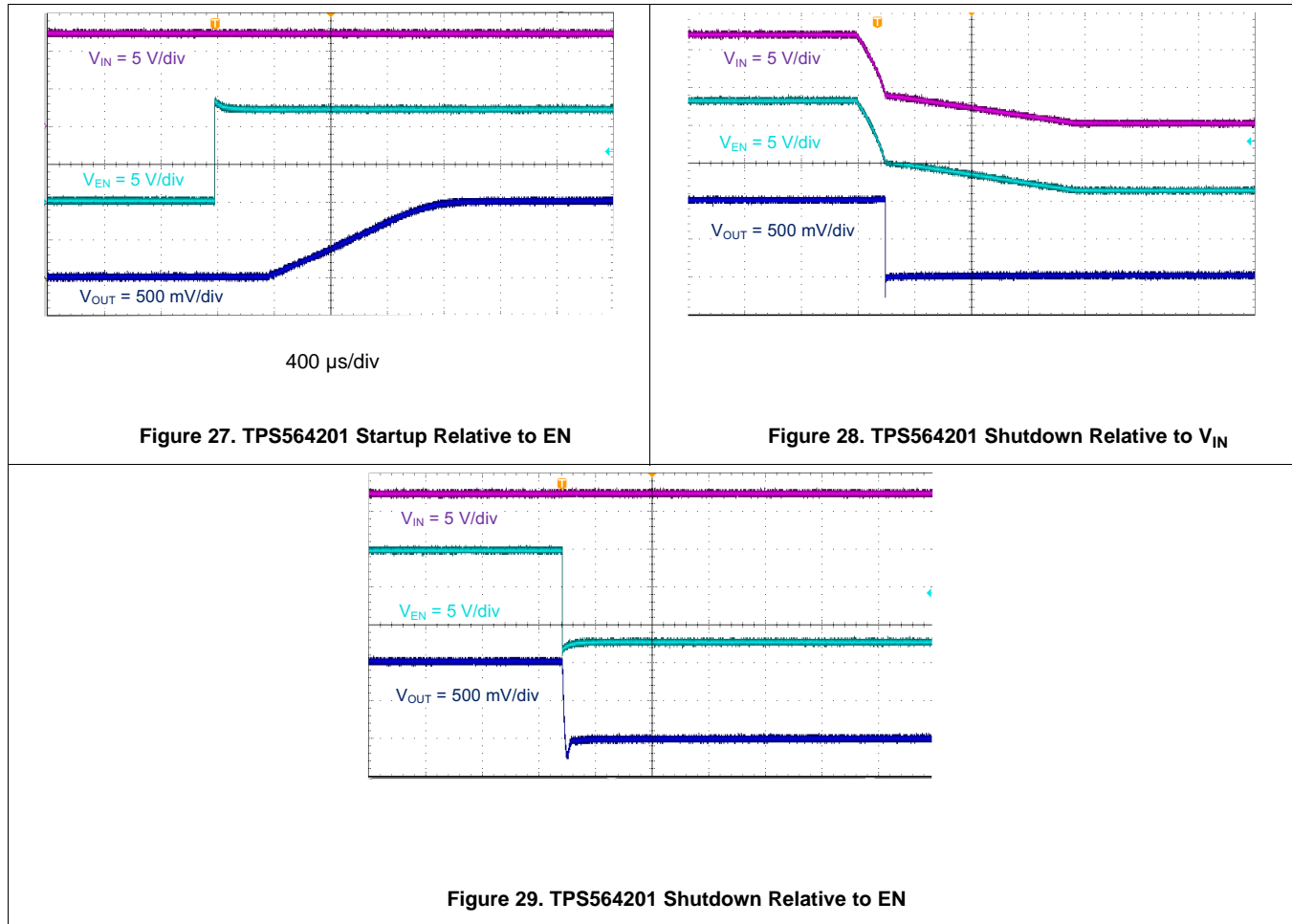

## 9 Power Supply Recommendations

The TPS564201 is designed to operate from input supply voltage in the range of 4.5 V to 17 V. Buck converters require the input voltage to be higher than the output voltage for proper operation. The maximum recommended operating duty cycle is 75%. Using that criteria, the minimum recommended input voltage is  $V_O / 0.75$ .

## 10 Layout

### 10.1 Layout Guidelines

1. VIN and GND traces should be as wide as possible to reduce trace impedance. The wide areas are also of advantage from the view point of heat dissipation.
2. The input capacitor and output capacitor should be placed as close to the device as possible to minimize trace impedance.
3. Provide sufficient vias for the input capacitor and output capacitor.
4. Keep the SW trace as physically short and wide as practical to minimize radiated emissions.
5. Do not allow switching current to flow under the device.
6. A separate VOUT path should be connected to the upper feedback resistor.
7. Make a Kelvin connection to the GND pin for the feedback path.
8. Voltage feedback loop should be placed away from the high-voltage switching trace, and preferably has ground shield.
9. The trace of the VFB node should be as small as possible to avoid noise coupling.
10. The GND trace between the output capacitor and the GND pin should be as wide as possible to minimize its trace impedance.

### 10.2 Layout Example

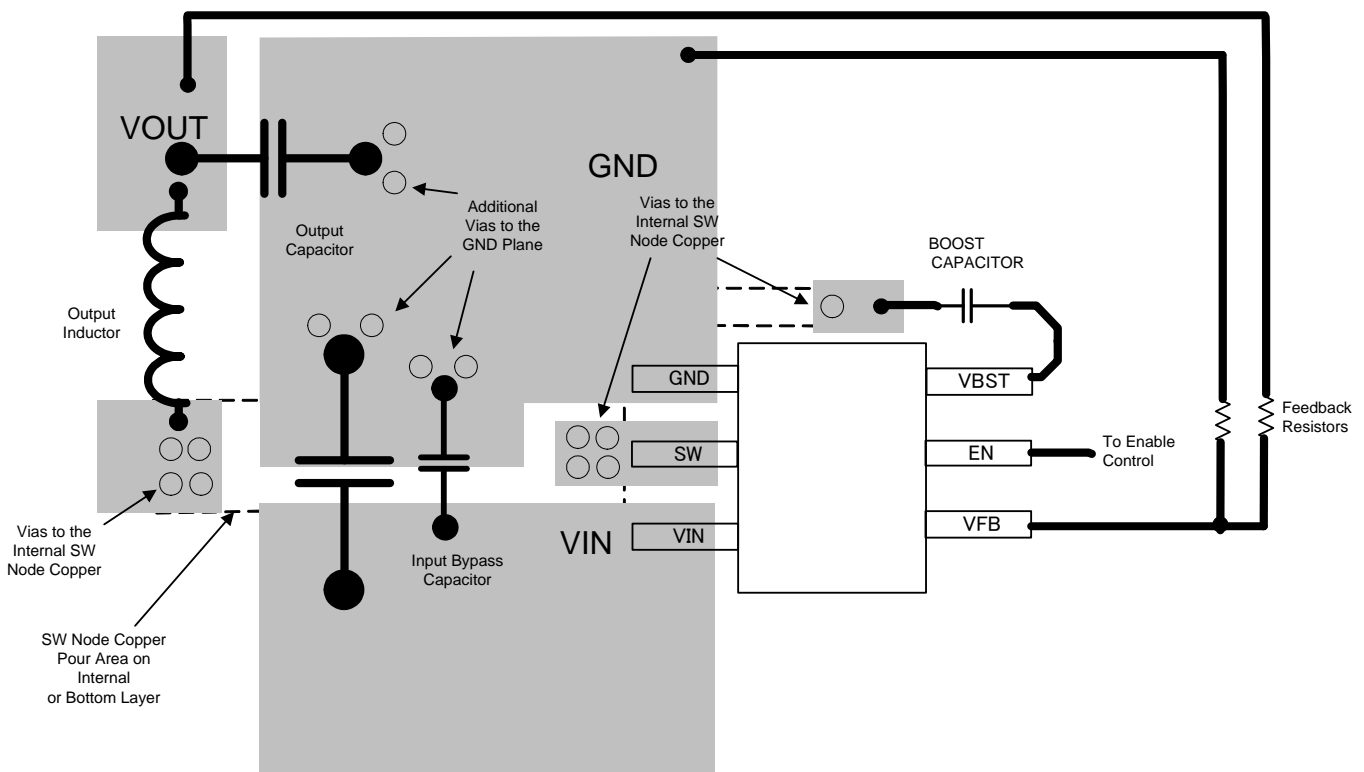

Figure 30. TPS564201 Layout Example

## 11 Device and Documentation Support

### 11.1 Development Support

#### 11.1.1 Custom Design With WEBENCH® Tools

[Click here](#) to create a custom design using the TPS564201 device with the WEBENCH® Power Designer.

1. Start by entering the input voltage ( $V_{IN}$ ), output voltage ( $V_{OUT}$ ), and output current ( $I_{OUT}$ ) requirements.
2. Optimize the design for key parameters such as efficiency, footprint, and cost using the optimizer dial.
3. Compare the generated design with other possible solutions from Texas Instruments.

The WEBENCH Power Designer provides a customized schematic along with a list of materials with real-time pricing and component availability.

In most cases, these actions are available:

- Run electrical simulations to see important waveforms and circuit performance
- Run thermal simulations to understand board thermal performance
- Export customized schematic and layout into popular CAD formats
- Print PDF reports for the design, and share the design with colleagues

Get more information about WEBENCH tools at [www.ti.com/WEBENCH](http://www.ti.com/WEBENCH).

#### 11.2 Receiving Notification of Documentation Updates

To receive notification of documentation updates, navigate to the device product folder on ti.com. In the upper right corner, click on *Alert me* to register and receive a weekly digest of any product information that has changed. For change details, review the revision history included in any revised document.

#### 11.3 Community Resources

The following links connect to TI community resources. Linked contents are provided "AS IS" by the respective contributors. They do not constitute TI specifications and do not necessarily reflect TI's views; see TI's [Terms of Use](#).

**TI E2E™ Online Community** *TI's Engineer-to-Engineer (E2E) Community*. Created to foster collaboration among engineers. At [e2e.ti.com](http://e2e.ti.com), you can ask questions, share knowledge, explore ideas and help solve problems with fellow engineers.

**Design Support** *TI's Design Support* Quickly find helpful E2E forums along with design support tools and contact information for technical support.

#### 11.4 Trademarks

D-CAP2, Eco-mode, E2E are trademarks of Texas Instruments.  
 WEBENCH is a registered trademark of Texas Instruments.  
 Blu-ray is a trademark of Blu-ray Disc Association.  
 All other trademarks are the property of their respective owners.

#### 11.5 Electrostatic Discharge Caution



These devices have limited built-in ESD protection. The leads should be shorted together or the device placed in conductive foam during storage or handling to prevent electrostatic damage to the MOS gates.

#### 11.6 Glossary

[SLYZ022](#) — *TI Glossary*.

This glossary lists and explains terms, acronyms, and definitions.

## 12 Mechanical, Packaging, and Orderable Information

The following pages include mechanical, packaging, and orderable information. This information is the most current data available for the designated devices. This data is subject to change without notice and revision of this document. For browser-based versions of this data sheet, refer to the left-hand navigation.

**PACKAGING INFORMATION**

| Orderable Device | Status<br>(1) | Package Type | Package Drawing | Pins | Package Qty | Eco Plan<br>(2)         | Lead/Ball Finish<br>(6) | MSL Peak Temp<br>(3) | Op Temp (°C) | Device Marking<br>(4/5) | Samples                 |
|------------------|---------------|--------------|-----------------|------|-------------|-------------------------|-------------------------|----------------------|--------------|-------------------------|-------------------------|
| TPS564201DDCR    | ACTIVE        | SOT-23-THIN  | DDC             | 6    | 3000        | Green (RoHS & no Sb/Br) | CU SN                   | Level-1-260C-UNLIM   | -40 to 125   | 4201                    | <a href="#">Samples</a> |
| TPS564201DDCT    | ACTIVE        | SOT-23-THIN  | DDC             | 6    | 250         | Green (RoHS & no Sb/Br) | CU SN                   | Level-1-260C-UNLIM   | -40 to 125   | 4201                    | <a href="#">Samples</a> |

(1) The marketing status values are defined as follows:

**ACTIVE:** Product device recommended for new designs.

**LIFEBUY:** TI has announced that the device will be discontinued, and a lifetime-buy period is in effect.

**NRND:** Not recommended for new designs. Device is in production to support existing customers, but TI does not recommend using this part in a new design.

**PREVIEW:** Device has been announced but is not in production. Samples may or may not be available.

**OBsolete:** TI has discontinued the production of the device.

(2) **RoHS:** TI defines "RoHS" to mean semiconductor products that are compliant with the current EU RoHS requirements for all 10 RoHS substances, including the requirement that RoHS substance do not exceed 0.1% by weight in homogeneous materials. Where designed to be soldered at high temperatures, "RoHS" products are suitable for use in specified lead-free processes. TI may reference these types of products as "Pb-Free".

**RoHS Exempt:** TI defines "RoHS Exempt" to mean products that contain lead but are compliant with EU RoHS pursuant to a specific EU RoHS exemption.

**Green:** TI defines "Green" to mean the content of Chlorine (Cl) and Bromine (Br) based flame retardants meet JS709B low halogen requirements of <=1000ppm threshold. Antimony trioxide based flame retardants must also meet the <=1000ppm threshold requirement.

(3) MSL, Peak Temp. - The Moisture Sensitivity Level rating according to the JEDEC industry standard classifications, and peak solder temperature.

(4) There may be additional marking, which relates to the logo, the lot trace code information, or the environmental category on the device.

(5) Multiple Device Markings will be inside parentheses. Only one Device Marking contained in parentheses and separated by a "~" will appear on a device. If a line is indented then it is a continuation of the previous line and the two combined represent the entire Device Marking for that device.

(6) Lead/Ball Finish - Orderable Devices may have multiple material finish options. Finish options are separated by a vertical ruled line. Lead/Ball Finish values may wrap to two lines if the finish value exceeds the maximum column width.

**Important Information and Disclaimer:**The information provided on this page represents TI's knowledge and belief as of the date that it is provided. TI bases its knowledge and belief on information provided by third parties, and makes no representation or warranty as to the accuracy of such information. Efforts are underway to better integrate information from third parties. TI has taken and continues to take reasonable steps to provide representative and accurate information but may not have conducted destructive testing or chemical analysis on incoming materials and chemicals. TI and TI suppliers consider certain information to be proprietary, and thus CAS numbers and other limited information may not be available for release.

In no event shall TI's liability arising out of such information exceed the total purchase price of the TI part(s) at issue in this document sold by TI to Customer on an annual basis.



## TAPE AND REEL INFORMATION



### QUADRANT ASSIGNMENTS FOR PIN 1 ORIENTATION IN TAPE



\*All dimensions are nominal

| Device        | Package Type | Package Drawing | Pins | SPQ  | Reel Diameter (mm) | Reel Width W1 (mm) | A0 (mm) | B0 (mm) | K0 (mm) | P1 (mm) | W (mm) | Pin1 Quadrant |
|---------------|--------------|-----------------|------|------|--------------------|--------------------|---------|---------|---------|---------|--------|---------------|
| TPS564201DDCR | SOT-23-THIN  | DDC             | 6    | 3000 | 180.0              | 9.5                | 3.17    | 3.1     | 1.1     | 4.0     | 8.0    | Q3            |
| TPS564201DDCT | SOT-23-THIN  | DDC             | 6    | 250  | 180.0              | 9.5                | 3.17    | 3.1     | 1.1     | 4.0     | 8.0    | Q3            |

**TAPE AND REEL BOX DIMENSIONS**

\*All dimensions are nominal

| Device        | Package Type | Package Drawing | Pins | SPQ  | Length (mm) | Width (mm) | Height (mm) |
|---------------|--------------|-----------------|------|------|-------------|------------|-------------|
| TPS564201DDCR | SOT-23-THIN  | DDC             | 6    | 3000 | 184.0       | 184.0      | 19.0        |
| TPS564201DDCT | SOT-23-THIN  | DDC             | 6    | 250  | 184.0       | 184.0      | 19.0        |

DDC (R-PDSO-G6)

PLASTIC SMALL-OUTLINE

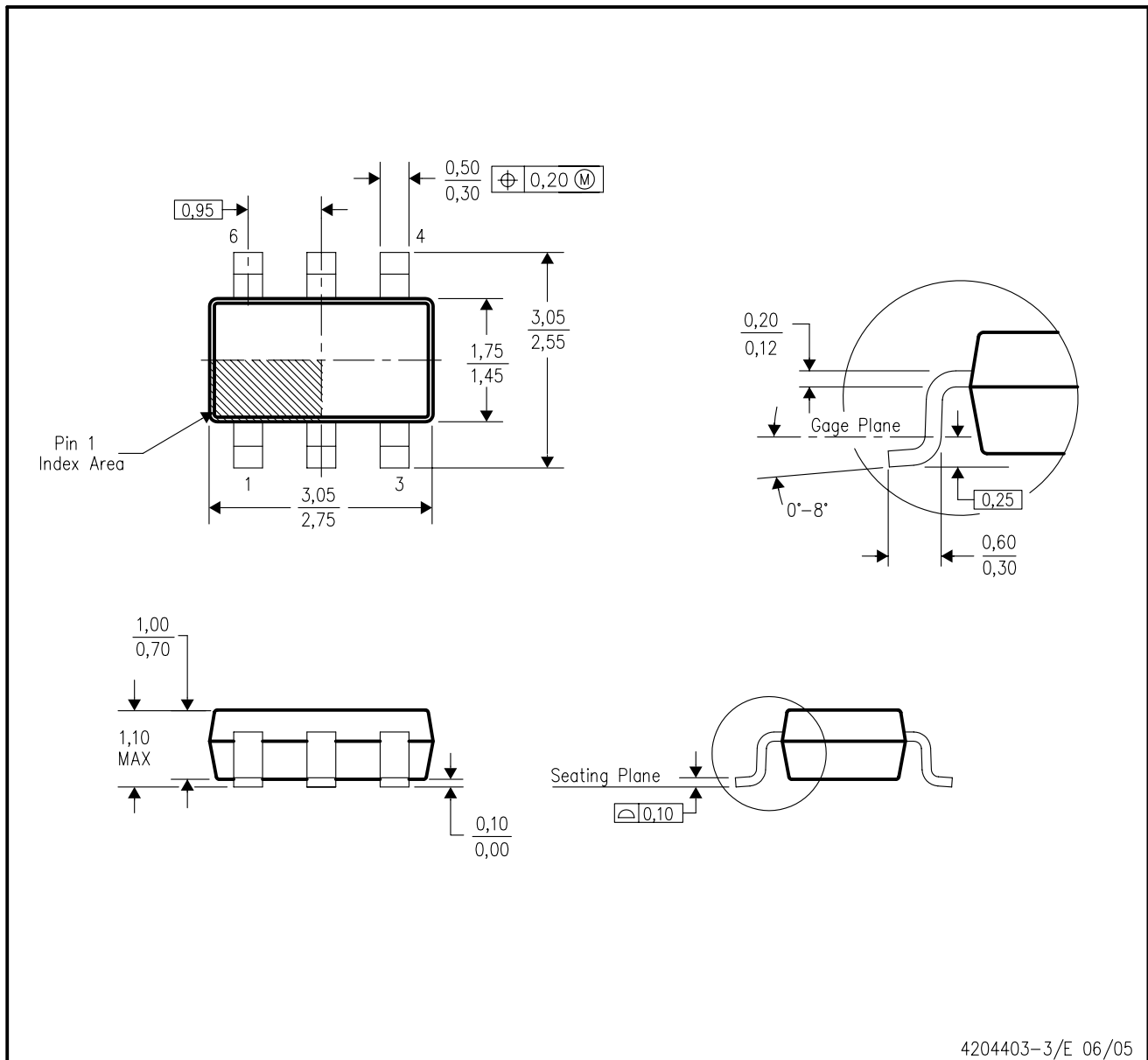

- NOTES:
- All linear dimensions are in millimeters.
  - This drawing is subject to change without notice.
  - Body dimensions do not include mold flash or protrusion.
  - Falls within JEDEC MO-193 variation AA (6 pin).

## IMPORTANT NOTICE AND DISCLAIMER

TI PROVIDES TECHNICAL AND RELIABILITY DATA (INCLUDING DATASHEETS), DESIGN RESOURCES (INCLUDING REFERENCE DESIGNS), APPLICATION OR OTHER DESIGN ADVICE, WEB TOOLS, SAFETY INFORMATION, AND OTHER RESOURCES "AS IS" AND WITH ALL FAULTS, AND DISCLAIMS ALL WARRANTIES, EXPRESS AND IMPLIED, INCLUDING WITHOUT LIMITATION ANY IMPLIED WARRANTIES OF MERCHANTABILITY, FITNESS FOR A PARTICULAR PURPOSE OR NON-INFRINGEMENT OF THIRD PARTY INTELLECTUAL PROPERTY RIGHTS.

These resources are intended for skilled developers designing with TI products. You are solely responsible for (1) selecting the appropriate TI products for your application, (2) designing, validating and testing your application, and (3) ensuring your application meets applicable standards, and any other safety, security, or other requirements. These resources are subject to change without notice. TI grants you permission to use these resources only for development of an application that uses the TI products described in the resource. Other reproduction and display of these resources is prohibited. No license is granted to any other TI intellectual property right or to any third party intellectual property right. TI disclaims responsibility for, and you will fully indemnify TI and its representatives against, any claims, damages, costs, losses, and liabilities arising out of your use of these resources.

TI's products are provided subject to TI's Terms of Sale ([www.ti.com/legal/termsofsale.html](http://www.ti.com/legal/termsofsale.html)) or other applicable terms available either on [ti.com](http://ti.com) or provided in conjunction with such TI products. TI's provision of these resources does not expand or otherwise alter TI's applicable warranties or warranty disclaimers for TI products.

Mailing Address: Texas Instruments, Post Office Box 655303, Dallas, Texas 75265  
Copyright © 2019, Texas Instruments Incorporated

## Looking for pricing, stock, or lifecycle information?

Click below to explore more details on WIN SOURCE:

 [View TPS564201DDCT on WIN SOURCE](#)

 [Texas Instruments](#) Information

## Optimize Your Supply Chain with WIN SOURCE Solutions

-  Global Sourcing Solution
-  Obsolete Management
-  Cost Control Management
-  Shortage Management
-  Alternative Solution
-  Excess Inventory Management