

## Precision Micropower Shunt Voltage Reference

### Features

- Small SOT-23 Package
- No Output Capacitor Required
- Tolerates Capacitive Loads
- Fixed Reverse-Breakdown Voltages of 1.225V, 2.500V, 4.096V, and 5.000V
- Adjustable Reverse-Breakdown Version

### Applications

- Battery-Powered Equipment
- Data Acquisition Systems
- Instrumentation
- Process Control
- Energy Management
- Product Testing
- Automotive Electronics
- Precision Audio Components

### General Description

Ideal for space critical applications, the LM4040 and LM4041 precision voltage references are available in the subminiature SOT-23 surface-mount package.

The LM4040 is available in fixed reverse-breakdown voltages of 2.500V, 4.096V, and 5.000V. The LM4041 is available with a fixed 1.225V or an adjustable reverse-breakdown voltage.

The minimum operating current ranges from 60  $\mu$ A for the LM4041-1.2 to 74  $\mu$ A for the LM4040-5.0. LM4040 versions have a maximum operating current of 15 mA. LM4041 versions have a maximum operating current of 12 mA.

The LM4040 and LM4041 have bandgap reference temperature drift curvature correction and low dynamic impedance, ensuring stable reverse-breakdown voltage accuracy over a wide range of operating temperatures and currents.

### Package Types

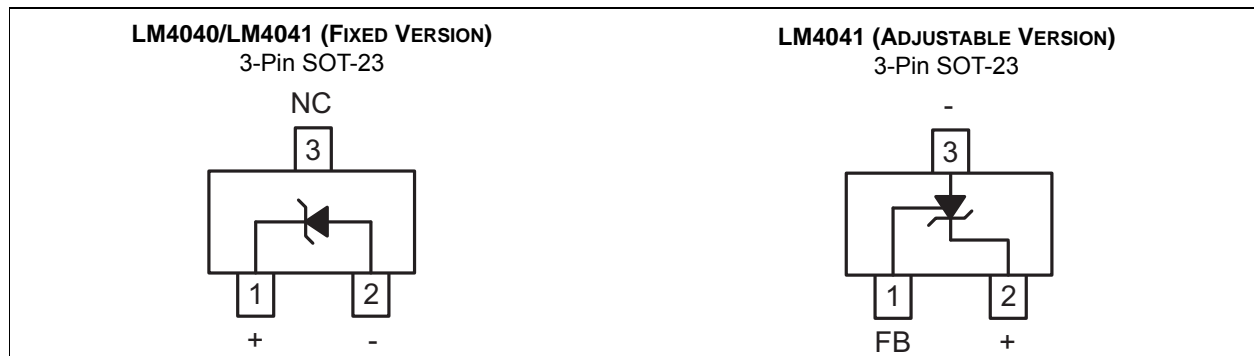

# LM4040/LM4041

## Typical Application Diagrams

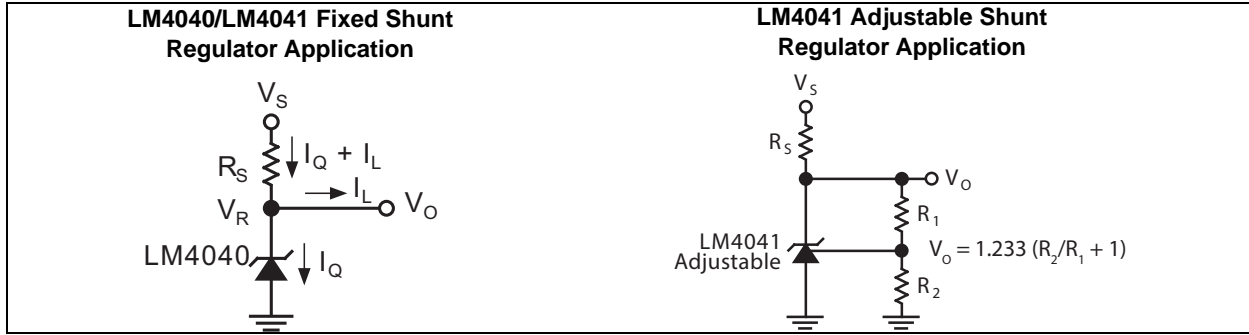

## Functional Block Diagrams

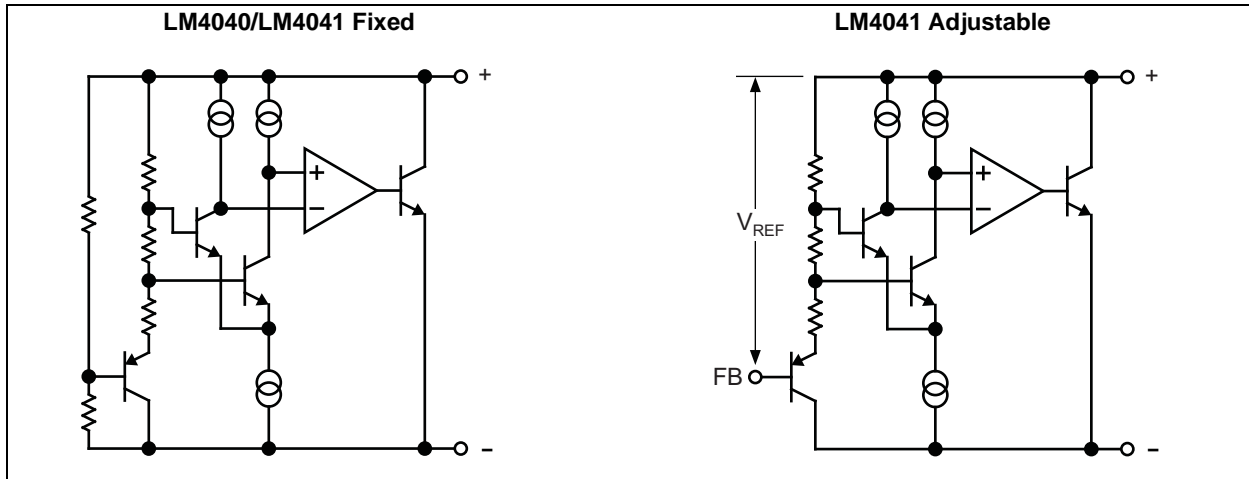

## 1.0 ELECTRICAL CHARACTERISTICS

### Absolute Maximum Ratings †

Reverse Current.....	20 mA
Forward Current.....	10 mA
Maximum Output Voltage (LM4041-ADJ) .....	15V
Power Dissipation ( $T_A = +25^\circ\text{C}$ ; <a href="#">Note 1</a> ).....	306 mW
ESD Susceptibility (HBM; <a href="#">Note 2</a> ).....	2 kV
ESD Susceptibility (MM; <a href="#">Note 2</a> ).....	200V

### Operating Ratings ‡

Reverse Current (LM4040-2.5) .....	60 $\mu\text{A}$ to 15 mA
Reverse Current (LM4040-4.1) .....	68 $\mu\text{A}$ to 15 mA
Reverse Current (LM4040-5.0) .....	74 $\mu\text{A}$ to 15 mA
Reverse Current (LM4041-1.2) .....	60 $\mu\text{A}$ to 12 mA
Reverse Current (LM4041-ADJ) .....	60 $\mu\text{A}$ to 12 mA
Output Voltage Range (LM4041-ADJ) .....	1.24V to 10V

† **Notice:** Stresses above those listed under “Absolute Maximum Ratings” may cause permanent damage to the device. This is a stress rating only and functional operation of the device at those or any other conditions above those indicated in the operational sections of this specification is not intended. Exposure to maximum rating conditions for extended periods may affect device reliability.

‡ **Notice:** The device is not guaranteed to function outside its operating ratings.

**Note 1:** The maximum power dissipation must be derated at elevated temperatures and is dictated by  $T_{JMAX}$  (maximum junction temperature),  $\Theta_{JA}$  (junction-to-ambient thermal resistance), and  $T_A$  (ambient temperature). The maximum allowable power dissipation at any temperature is  $P_{DMAX} = (T_{JMAX} - T_A) / \Theta_{JA}$  or the number given in the Absolute Maximum Ratings, whichever is lower. For the LM4040 and LM4041,  $T_{JMAX} = +125^\circ\text{C}$  and the typical thermal resistance, when board-mounted, is  $+326^\circ\text{C}/\text{W}$  for the SOT-23 package.

**2:** Devices are ESD sensitive. Handling precautions are recommended. Human body model, 1.5 k $\Omega$  in series with 100 pF. The machine model is a 200 pF capacitor discharged directly into each pin.

# LM4040/LM4041

## LM4040-2.5 ELECTRICAL CHARACTERISTICS (Note 1)

$T_A$  = Operating Temperature Range,  $T_A = T_J = -40^\circ\text{C}$  to  $+85^\circ\text{C}$ , unless noted.

Parameters	Sym.	Min.	Typ.	Max.	Units	Conditions
<b>LM4040C</b>						
Reverse-Breakdown Voltage	$V_R$	—	2.500	—	V	$I_R = 100\ \mu\text{A}$ , $T_A = +25^\circ\text{C}$
Reverse-Breakdown Voltage Tolerance (Note 2)		—	—	$\pm 12$	mV	$I_R = 100\ \mu\text{A}$ , $T_A = +25^\circ\text{C}$
		—	—	$\pm 29$	mV	$I_R = 100\ \mu\text{A}$
Minimum Operating Current	$I_{RMIN}$	—	45	60	$\mu\text{A}$	$T_A = +25^\circ\text{C}$
		—	—	65		—
Average Reverse-Breakdown Voltage Temperature Coefficient	$\Delta V_R/\Delta T$	—	$\pm 20$	—	ppm/ $^\circ\text{C}$	$I_R = 10\ \text{mA}$ , $T_A = +25^\circ\text{C}$
		—	$\pm 15$	$\pm 100$		$I_R = 1\ \text{mA}$
		—	$\pm 15$	—		$I_R = 100\ \mu\text{A}$ , $T_A = +25^\circ\text{C}$
Reverse-Breakdown Voltage Change with Operating Current Change	$\Delta V_R/\Delta I_R$	—	0.3	0.8	mV	$I_{RMIN} \leq I_R \leq 1\ \text{mA}$ , $T_A = +25^\circ\text{C}$
		—	—	1.0		$I_{RMIN} \leq I_R \leq 1\ \text{mA}$
		—	2.5	6.0		$1\ \text{mA} \leq I_R \leq 15\ \text{mA}$ , $T_A = +25^\circ\text{C}$
		—	—	8.0		$1\ \text{mA} \leq I_R \leq 15\ \text{mA}$
Reverse Dynamic Impedance	$Z_R$	—	0.3	0.9	$\Omega$	$I_R = 1\ \text{mA}$ , $f = 120\ \text{Hz}$ , $I_{AC} = 0.1 I_R$ , $T_A = +25^\circ\text{C}$
Wideband Noise	$e_N$	—	35	—	$\mu\text{V}_{RMS}$	$I_R = 100\ \mu\text{A}$ , $T_A = +25^\circ\text{C}$ , $10\ \text{Hz} \leq f \leq 10\ \text{kHz}$
Reverse-Breakdown Voltage Long-Term Stability	$\Delta V_R$	—	120	—	ppm	$t = 1000\ \text{hrs.}$ , $T_A = +25^\circ\text{C}$ $\pm 0.1^\circ\text{C}$ , $I_R = 100\ \mu\text{A}$
<b>LM4040D</b>						
Reverse-Breakdown Voltage	$V_R$	—	2.500	—	V	$I_R = 100\ \mu\text{A}$ , $T_A = +25^\circ\text{C}$
Reverse-Breakdown Voltage Tolerance (Note 2)		—	—	$\pm 25$	mV	$I_R = 100\ \mu\text{A}$ , $T_A = +25^\circ\text{C}$
		—	—	$\pm 49$	mV	$I_R = 100\ \mu\text{A}$
Minimum Operating Current	$I_{RMIN}$	—	45	65	$\mu\text{A}$	$T_A = +25^\circ\text{C}$
		—	—	70		—
Average Reverse-Breakdown Voltage Temperature Coefficient	$\Delta V_R/\Delta T$	—	$\pm 20$	—	ppm/ $^\circ\text{C}$	$I_R = 10\ \text{mA}$ , $T_A = +25^\circ\text{C}$
		—	$\pm 15$	$\pm 150$		$I_R = 1\ \text{mA}$
		—	$\pm 15$	—		$I_R = 100\ \mu\text{A}$ , $T_A = +25^\circ\text{C}$

**Note 1:** Specification for packaged product only.

- 2:** The boldface (overtemperature) limit for Reverse-Breakdown Voltage Tolerance is defined as the room temperature Reverse-Breakdown Voltage Tolerance  $\pm[(\Delta V_R/\Delta T)(65^\circ\text{C})(V_R)]$ .  $\Delta V_R/\Delta T$  is the  $V_R$  temperature coefficient,  $65^\circ\text{C}$  is the temperature range from  $-40^\circ\text{C}$  to the reference point of  $25^\circ\text{C}$ , and  $V_R$  is the reverse-breakdown voltage. The total overtemperature tolerance for the different grades follows:

a. C-grade:  $\pm 1.15\% = \pm 0.5\% \pm 100\ \text{ppm}/^\circ\text{C} \times 65^\circ\text{C}$

b. D-grade:  $\pm 1.98\% = \pm 1.0\% \pm 150\ \text{ppm}/^\circ\text{C} \times 65^\circ\text{C}$

Example: The C-grade LM4040-2.5 has an overtemperature Reverse-Breakdown Voltage tolerance of  $\pm 2.5 \times 1.15\% = \pm 29\ \text{mV}$ .

## LM4040-2.5 ELECTRICAL CHARACTERISTICS (Note 1) (CONTINUED)

$T_A$  = Operating Temperature Range,  $T_A = T_J = -40^\circ\text{C}$  to  $+85^\circ\text{C}$ , unless noted.

Parameters	Sym.	Min.	Typ.	Max.	Units	Conditions
Reverse-Breakdown Voltage Change with Operating Current Change	$\Delta V_R/\Delta I_R$	—	0.3	1.0	mV	$I_{RMIN} \leq I_R \leq 1 \text{ mA}$ , $T_A = +25^\circ\text{C}$
		—	—	1.2		$I_{RMIN} \leq I_R \leq 1 \text{ mA}$
		—	2.5	8.0		$1 \text{ mA} \leq I_R \leq 15 \text{ mA}$ , $T_A = +25^\circ\text{C}$
		—	—	10.0		$1 \text{ mA} \leq I_R \leq 15 \text{ mA}$
Reverse Dynamic Impedance	$Z_R$	—	0.3	1.1	$\Omega$	$I_R = 1 \text{ mA}$ , $f = 120 \text{ Hz}$ , $I_{AC} = 0.1 I_R$ , $T_A = +25^\circ\text{C}$
Wideband Noise	$e_N$	—	35	—	$\mu\text{V}_{RMS}$	$I_R = 100 \mu\text{A}$ , $10 \text{ Hz} \leq f \leq 10 \text{ kHz}$
Reverse-Breakdown Voltage Long-Term Stability	$\Delta V_R$	—	120	—	ppm	$t = 1000 \text{ hrs.}$ , $T_A = +25^\circ\text{C}$ $\pm 0.1^\circ\text{C}$ , $I_R = 100 \mu\text{A}$

**Note 1:** Specification for packaged product only.

**2:** The boldface (overtemperature) limit for Reverse-Breakdown Voltage Tolerance is defined as the room temperature Reverse-Breakdown Voltage Tolerance  $\pm[(\Delta V_R/\Delta T)(65^\circ\text{C})(V_R)]$ .  $\Delta V_R/\Delta T$  is the  $V_R$  temperature coefficient,  $65^\circ\text{C}$  is the temperature range from  $-40^\circ\text{C}$  to the reference point of  $25^\circ\text{C}$ , and  $V_R$  is the reverse-breakdown voltage. The total overtemperature tolerance for the different grades follows:

a. C-grade:  $\pm 1.15\% = \pm 0.5\% \pm 100 \text{ ppm}/^\circ\text{C} \times 65^\circ\text{C}$

b. D-grade:  $\pm 1.98\% = \pm 1.0\% \pm 150 \text{ ppm}/^\circ\text{C} \times 65^\circ\text{C}$

Example: The C-grade LM4040-2.5 has an overtemperature Reverse-Breakdown Voltage tolerance of  $\pm 2.5 \times 1.15\% = \pm 29 \text{ mV}$ .

# LM4040/LM4041

## LM4040-4.1 ELECTRICAL CHARACTERISTICS (Note 1)

$T_A$  = Operating Temperature Range,  $T_A = T_J = -40^\circ\text{C}$  to  $+85^\circ\text{C}$ , unless noted.

Parameters	Sym.	Min.	Typ.	Max.	Units	Conditions
<b>LM4040C</b>						
Reverse-Breakdown Voltage	$V_R$	—	4.096	—	V	$I_R = 100\ \mu\text{A}$ , $T_A = +25^\circ\text{C}$
Reverse-Breakdown Voltage Tolerance (Note 2)		—	—	$\pm 20$	mV	$I_R = 100\ \mu\text{A}$ , $T_A = +25^\circ\text{C}$
		—	—	$\pm 47$	mV	$I_R = 100\ \mu\text{A}$
Minimum Operating Current	$I_{RMIN}$	—	50	68	$\mu\text{A}$	$T_A = +25^\circ\text{C}$
		—	—	73		—
Average Reverse-Breakdown Voltage Temperature Coefficient	$\Delta V_R/\Delta T$	—	$\pm 30$	—	ppm/ $^\circ\text{C}$	$I_R = 10\ \text{mA}$ , $T_A = +25^\circ\text{C}$
		—	$\pm 20$	$\pm 100$		$I_R = 1\ \text{mA}$
		—	$\pm 20$	—		$I_R = 100\ \mu\text{A}$ , $T_A = +25^\circ\text{C}$
Reverse-Breakdown Voltage Change with Operating Current Change	$\Delta V_R/\Delta I_R$	—	0.5	0.9	mV	$I_{RMIN} \leq I_R \leq 1\ \text{mA}$ , $T_A = +25^\circ\text{C}$
		—	—	1.2		$I_{RMIN} \leq I_R \leq 1\ \text{mA}$
		—	3.0	7.0		$1\ \text{mA} \leq I_R \leq 15\ \text{mA}$ , $T_A = +25^\circ\text{C}$
		—	—	10.0		$1\ \text{mA} \leq I_R \leq 15\ \text{mA}$
Reverse Dynamic Impedance	$Z_R$	—	0.5	1.0	$\Omega$	$I_R = 1\ \text{mA}$ , $f = 120\ \text{Hz}$ , $I_{AC} = 0.1 I_R$ , $T_A = +25^\circ\text{C}$
Wideband Noise	$e_N$	—	80	—	$\mu\text{V}_{RMS}$	$I_R = 100\ \mu\text{A}$ , $T_A = +25^\circ\text{C}$ , $10\ \text{Hz} \leq f \leq 10\ \text{kHz}$
Reverse-Breakdown Voltage Long-Term Stability	$\Delta V_R$	—	120	—	ppm	$t = 1000\ \text{hrs.}$ , $T_A = +25^\circ\text{C}$ $\pm 0.1^\circ\text{C}$ , $I_R = 100\ \mu\text{A}$
<b>LM4040D</b>						
Reverse-Breakdown Voltage	$V_R$	—	4.096	—	V	$I_R = 100\ \mu\text{A}$ , $T_A = +25^\circ\text{C}$
Reverse-Breakdown Voltage Tolerance (Note 2)		—	—	$\pm 41$	mV	$I_R = 100\ \mu\text{A}$ , $T_A = +25^\circ\text{C}$
		—	—	$\pm 81$	mV	$I_R = 100\ \mu\text{A}$
Minimum Operating Current	$I_{RMIN}$	—	50	73	$\mu\text{A}$	$T_A = +25^\circ\text{C}$
		—	—	78		—
Average Reverse-Breakdown Voltage Temperature Coefficient	$\Delta V_R/\Delta T$	—	$\pm 30$	—	ppm/ $^\circ\text{C}$	$I_R = 10\ \text{mA}$ , $T_A = +25^\circ\text{C}$
		—	$\pm 20$	$\pm 150$		$I_R = 1\ \text{mA}$
		—	$\pm 20$	—		$I_R = 100\ \mu\text{A}$ , $T_A = +25^\circ\text{C}$

**Note 1:** Specification for packaged product only.

- 2:** The boldface (overtemperature) limit for Reverse-Breakdown Voltage Tolerance is defined as the room temperature Reverse-Breakdown Voltage Tolerance  $\pm[(\Delta V_R/\Delta T)(65^\circ\text{C})(V_R)]$ .  $\Delta V_R/\Delta T$  is the  $V_R$  temperature coefficient,  $65^\circ\text{C}$  is the temperature range from  $-40^\circ\text{C}$  to the reference point of  $25^\circ\text{C}$ , and  $V_R$  is the reverse-breakdown voltage. The total overtemperature tolerance for the different grades follows:

a. C-grade:  $\pm 1.15\% = \pm 0.5\% \pm 100\ \text{ppm}/^\circ\text{C} \times 65^\circ\text{C}$

b. D-grade:  $\pm 1.98\% = \pm 1.0\% \pm 150\ \text{ppm}/^\circ\text{C} \times 65^\circ\text{C}$

Example: The C-grade LM4040-2.5 has an overtemperature Reverse-Breakdown Voltage tolerance of  $\pm 2.5 \times 1.15\% = \pm 29\ \text{mV}$ .

## LM4040-4.1 ELECTRICAL CHARACTERISTICS (Note 1) (CONTINUED)

$T_A$  = Operating Temperature Range,  $T_A = T_J = -40^\circ\text{C}$  to  $+85^\circ\text{C}$ , unless noted.

Parameters	Sym.	Min.	Typ.	Max.	Units	Conditions
Reverse-Breakdown Voltage Change with Operating Current Change	$\Delta V_R/\Delta I_R$	—	0.5	1.2	mV	$I_{RMIN} \leq I_R \leq 1 \text{ mA}$ , $T_A = +25^\circ\text{C}$
		—	—	1.5		$I_{RMIN} \leq I_R \leq 1 \text{ mA}$
		—	3.0	9.0		$1 \text{ mA} \leq I_R \leq 15 \text{ mA}$ , $T_A = +25^\circ\text{C}$
		—	—	13.0		$1 \text{ mA} \leq I_R \leq 15 \text{ mA}$
Reverse Dynamic Impedance	$Z_R$	—	0.5	1.3	$\Omega$	$I_R = 1 \text{ mA}$ , $f = 120 \text{ Hz}$ , $I_{AC} = 0.1 I_R$ , $T_A = +25^\circ\text{C}$
Wideband Noise	$e_N$	—	80	—	$\mu\text{V}_{RMS}$	$I_R = 100 \mu\text{A}$ , $T_A = +25^\circ\text{C}$ $10 \text{ Hz} \leq f \leq 10 \text{ kHz}$
Reverse-Breakdown Voltage Long-Term Stability	$\Delta V_R$	—	120	—	ppm	$t = 1000 \text{ hrs.}$ , $T_A = +25^\circ\text{C}$ $\pm 0.1^\circ\text{C}$ , $I_R = 100 \mu\text{A}$

**Note 1:** Specification for packaged product only.

**2:** The boldface (overtemperature) limit for Reverse-Breakdown Voltage Tolerance is defined as the room temperature Reverse-Breakdown Voltage Tolerance  $\pm[(\Delta V_R/\Delta T)(65^\circ\text{C})(V_R)]$ .  $\Delta V_R/\Delta T$  is the  $V_R$  temperature coefficient,  $65^\circ\text{C}$  is the temperature range from  $-40^\circ\text{C}$  to the reference point of  $25^\circ\text{C}$ , and  $V_R$  is the reverse-breakdown voltage. The total overtemperature tolerance for the different grades follows:

a. C-grade:  $\pm 1.15\% = \pm 0.5\% \pm 100 \text{ ppm}/^\circ\text{C} \times 65^\circ\text{C}$

b. D-grade:  $\pm 1.98\% = \pm 1.0\% \pm 150 \text{ ppm}/^\circ\text{C} \times 65^\circ\text{C}$

Example: The C-grade LM4040-2.5 has an overtemperature Reverse-Breakdown Voltage tolerance of  $\pm 2.5 \times 1.15\% = \pm 29 \text{ mV}$ .

# LM4040/LM4041

## LM4040-5.0 ELECTRICAL CHARACTERISTICS (Note 1)

$T_A$  = Operating Temperature Range,  $T_A = T_J = -40^\circ\text{C}$  to  $+85^\circ\text{C}$ , unless noted.

Parameters	Sym.	Min.	Typ.	Max.	Units	Conditions
<b>LM4040C</b>						
Reverse-Breakdown Voltage	$V_R$	—	5.000	—	V	$I_R = 100\ \mu\text{A}$ , $T_A = +25^\circ\text{C}$
Reverse-Breakdown Voltage Tolerance (Note 2)		—	—	$\pm 25$	mV	$I_R = 100\ \mu\text{A}$ , $T_A = +25^\circ\text{C}$
		—	—	$\pm 58$	mV	$I_R = 100\ \mu\text{A}$
Minimum Operating Current	$I_{RMIN}$	—	54	74	$\mu\text{A}$	$T_A = +25^\circ\text{C}$
		—	—	80		—
Average Reverse-Breakdown Voltage Temperature Coefficient	$\Delta V_R/\Delta T$	—	$\pm 30$	—	ppm/ $^\circ\text{C}$	$I_R = 10\ \text{mA}$ , $T_A = +25^\circ\text{C}$
		—	$\pm 20$	$\pm 100$		$I_R = 1\ \text{mA}$
		—	$\pm 20$	—		$I_R = 100\ \mu\text{A}$ , $T_A = +25^\circ\text{C}$
Reverse-Breakdown Voltage Change with Operating Current Change	$\Delta V_R/\Delta I_R$	—	0.5	1.0	mV	$I_{RMIN} \leq I_R \leq 1\ \text{mA}$ , $T_A = +25^\circ\text{C}$
		—	—	1.4		$I_{RMIN} \leq I_R \leq 1\ \text{mA}$
		—	3.5	8.0		$1\ \text{mA} \leq I_R \leq 15\ \text{mA}$ , $T_A = +25^\circ\text{C}$
		—	—	12.0		$1\ \text{mA} \leq I_R \leq 15\ \text{mA}$
Reverse Dynamic Impedance	$Z_R$	—	0.5	1.1	$\Omega$	$I_R = 1\ \text{mA}$ , $f = 120\ \text{Hz}$ , $I_{AC} = 0.1 I_R$ , $T_A = +25^\circ\text{C}$
Wideband Noise	$e_N$	—	80	—	$\mu\text{V}_{RMS}$	$I_R = 100\ \mu\text{A}$ , $T_A = +25^\circ\text{C}$ , $10\ \text{Hz} \leq f \leq 10\ \text{kHz}$
Reverse-Breakdown Voltage Long-Term Stability	$\Delta V_R$	—	120	—	ppm	$t = 1000\ \text{hrs.}$ , $T_A = +25^\circ\text{C}$ $\pm 0.1^\circ\text{C}$ , $I_R = 100\ \mu\text{A}$
<b>LM4040D</b>						
Reverse-Breakdown Voltage	$V_R$	—	5.000	—	V	$I_R = 100\ \mu\text{A}$ , $T_A = +25^\circ\text{C}$
Reverse-Breakdown Voltage Tolerance (Note 2)		—	—	$\pm 50$	mV	$I_R = 100\ \mu\text{A}$ , $T_A = +25^\circ\text{C}$
		—	—	$\pm 99$	mV	$I_R = 100\ \mu\text{A}$
Minimum Operating Current	$I_{RMIN}$	—	54	79	$\mu\text{A}$	$T_A = +25^\circ\text{C}$
		—	—	85		—
Average Reverse-Breakdown Voltage Temperature Coefficient	$\Delta V_R/\Delta T$	—	$\pm 30$	—	ppm/ $^\circ\text{C}$	$I_R = 10\ \text{mA}$ , $T_A = +25^\circ\text{C}$
		—	$\pm 20$	$\pm 150$		$I_R = 1\ \text{mA}$
		—	$\pm 20$	—		$I_R = 100\ \mu\text{A}$ , $T_A = +25^\circ\text{C}$

**Note 1:** Specification for packaged product only.

- 2:** The boldface (overtemperature) limit for Reverse-Breakdown Voltage Tolerance is defined as the room temperature Reverse-Breakdown Voltage Tolerance  $\pm[(\Delta V_R/\Delta T)(65^\circ\text{C})(V_R)]$ .  $\Delta V_R/\Delta T$  is the  $V_R$  temperature coefficient,  $65^\circ\text{C}$  is the temperature range from  $-40^\circ\text{C}$  to the reference point of  $25^\circ\text{C}$ , and  $V_R$  is the reverse-breakdown voltage. The total overtemperature tolerance for the different grades follows:

a. C-grade:  $\pm 1.15\% = \pm 0.5\% \pm 100\ \text{ppm}/^\circ\text{C} \times 65^\circ\text{C}$

b. D-grade:  $\pm 1.98\% = \pm 1.0\% \pm 150\ \text{ppm}/^\circ\text{C} \times 65^\circ\text{C}$

Example: The C-grade LM4040-2.5 has an overtemperature Reverse-Breakdown Voltage tolerance of  $\pm 2.5 \times 1.15\% = \pm 29\ \text{mV}$ .

## LM4040-5.0 ELECTRICAL CHARACTERISTICS (Note 1) (CONTINUED)

$T_A$  = Operating Temperature Range,  $T_A = T_J = -40^\circ\text{C}$  to  $+85^\circ\text{C}$ , unless noted.

Parameters	Sym.	Min.	Typ.	Max.	Units	Conditions
Reverse-Breakdown Voltage Change with Operating Current Change	$\Delta V_R/\Delta I_R$	—	0.5	1.3	mV	$I_{RMIN} \leq I_R \leq 1 \text{ mA}$ , $T_A = +25^\circ\text{C}$
		—	—	1.8		$I_{RMIN} \leq I_R \leq 1 \text{ mA}$
		—	3.5	10.0		$1 \text{ mA} \leq I_R \leq 15 \text{ mA}$ , $T_A = +25^\circ\text{C}$
		—	—	15.0		$1 \text{ mA} \leq I_R \leq 15 \text{ mA}$
Reverse Dynamic Impedance	$Z_R$	—	0.5	1.5	$\Omega$	$I_R = 1 \text{ mA}$ , $f = 120 \text{ Hz}$ , $I_{AC} = 0.1 I_R$ , $T_A = +25^\circ\text{C}$
Wideband Noise	$e_N$	—	80	—	$\mu\text{V}_{RMS}$	$I_R = 100 \mu\text{A}$ , $T_A = +25^\circ\text{C}$ , $10 \text{ Hz} \leq f \leq 10 \text{ kHz}$
Reverse-Breakdown Voltage Long-Term Stability	$\Delta V_R$	—	120	—	ppm	$t = 1000 \text{ hrs.}$ , $T_A = +25^\circ\text{C}$ $\pm 0.1^\circ\text{C}$ , $I_R = 100 \mu\text{A}$

**Note 1:** Specification for packaged product only.

**2:** The boldface (overtemperature) limit for Reverse-Breakdown Voltage Tolerance is defined as the room temperature Reverse-Breakdown Voltage Tolerance  $\pm[(\Delta V_R/\Delta T)(65^\circ\text{C})(V_R)]$ .  $\Delta V_R/\Delta T$  is the  $V_R$  temperature coefficient,  $65^\circ\text{C}$  is the temperature range from  $-40^\circ\text{C}$  to the reference point of  $25^\circ\text{C}$ , and  $V_R$  is the reverse-breakdown voltage. The total overtemperature tolerance for the different grades follows:

a. C-grade:  $\pm 1.15\% = \pm 0.5\% \pm 100 \text{ ppm}/^\circ\text{C} \times 65^\circ\text{C}$

b. D-grade:  $\pm 1.98\% = \pm 1.0\% \pm 150 \text{ ppm}/^\circ\text{C} \times 65^\circ\text{C}$

Example: The C-grade LM4040-2.5 has an overtemperature Reverse-Breakdown Voltage tolerance of  $\pm 2.5 \times 1.15\% = \pm 29 \text{ mV}$ .

# LM4040/LM4041

## LM4041-1.2 ELECTRICAL CHARACTERISTICS (Note 1)

$T_A$  = Operating Temperature Range,  $T_A = T_J = -40^\circ\text{C}$  to  $+85^\circ\text{C}$ , unless noted.

Parameters	Sym.	Min.	Typ.	Max.	Units	Conditions
<b>LM4041C</b>						
Reverse-Breakdown Voltage	$V_R$	—	1.225	—	V	$I_R = 100\ \mu\text{A}$ , $T_A = +25^\circ\text{C}$
Reverse-Breakdown Voltage Tolerance (Note 2)		—	—	$\pm 6$	mV	$I_R = 100\ \mu\text{A}$ , $T_A = +25^\circ\text{C}$
		—	—	$\pm 14$	mV	$I_R = 100\ \mu\text{A}$
Minimum Operating Current	$I_{RMIN}$	—	45	60	$\mu\text{A}$	$T_A = +25^\circ\text{C}$
		—	—	65		—
Average Reverse-Breakdown Voltage Temperature Coefficient	$\Delta V_R/\Delta T$	—	$\pm 20$	—	ppm/ $^\circ\text{C}$	$I_R = 10\ \text{mA}$ , $T_A = +25^\circ\text{C}$
		—	$\pm 15$	$\pm 100$		$I_R = 1\ \text{mA}$
		—	$\pm 15$	—		$I_R = 100\ \mu\text{A}$ , $T_A = +25^\circ\text{C}$
Reverse-Breakdown Voltage Change with Operating Current Change	$\Delta V_R/\Delta I_R$	—	0.7	1.5	mV	$I_{RMIN} \leq I_R \leq 1\ \text{mA}$ , $T_A = +25^\circ\text{C}$
		—	—	2.0		$I_{RMIN} \leq I_R \leq 1\ \text{mA}$
		—	4.0	6.0		$1\ \text{mA} \leq I_R \leq 12\ \text{mA}$ , $T_A = +25^\circ\text{C}$
		—	—	8.0		$1\ \text{mA} \leq I_R \leq 12\ \text{mA}$
Reverse Dynamic Impedance	$Z_R$	—	0.5	1.5	$\Omega$	$I_R = 1\ \text{mA}$ , $f = 120\ \text{Hz}$ , $I_{AC} = 0.1 I_R$ , $T_A = +25^\circ\text{C}$
Wideband Noise	$e_N$	—	20	—	$\mu\text{V}_{RMS}$	$I_R = 100\ \mu\text{A}$ , $T_A = +25^\circ\text{C}$ , $10\ \text{Hz} \leq f \leq 10\ \text{kHz}$
Reverse-Breakdown Voltage Long-Term Stability	$\Delta V_R$	—	120	—	ppm	$t = 1000\ \text{hrs.}$ , $T_A = +25^\circ\text{C}$ $\pm 0.1^\circ\text{C}$ , $I_R = 100\ \mu\text{A}$
<b>LM4041D</b>						
Reverse-Breakdown Voltage	$V_R$	—	1.225	—	V	$I_R = 100\ \mu\text{A}$ , $T_A = +25^\circ\text{C}$
Reverse-Breakdown Voltage Tolerance (Note 2)		—	—	$\pm 12$	mV	$I_R = 100\ \mu\text{A}$ , $T_A = +25^\circ\text{C}$
		—	—	$\pm 24$		$I_R = 100\ \mu\text{A}$
Minimum Operating Current	$I_{RMIN}$	—	45	65	$\mu\text{A}$	$T_A = +25^\circ\text{C}$
		—	—	70		—
Average Reverse-Breakdown Voltage Temperature Coefficient	$\Delta V_R/\Delta T$	—	$\pm 20$	—	ppm/ $^\circ\text{C}$	$I_R = 10\ \text{mA}$ , $T_A = +25^\circ\text{C}$
		—	$\pm 15$	$\pm 150$		$I_R = 1\ \text{mA}$
		—	$\pm 15$	—		$I_R = 100\ \mu\text{A}$ , $T_A = +25^\circ\text{C}$

**Note 1:** Specification for packaged product only.

- 2:** The boldface (overtemperature) limit for Reverse-Breakdown Voltage Tolerance is defined as the room temperature Reverse-Breakdown Voltage Tolerance  $\pm[(\Delta V_R/\Delta T)(65^\circ\text{C})(V_R)]$ .  $\Delta V_R/\Delta T$  is the  $V_R$  temperature coefficient,  $65^\circ\text{C}$  is the temperature range from  $-40^\circ\text{C}$  to the reference point of  $25^\circ\text{C}$ , and  $V_R$  is the reverse-breakdown voltage. The total overtemperature tolerance for the different grades follows:

a. C-grade:  $\pm 1.15\% = \pm 0.5\% \pm 100\ \text{ppm}/^\circ\text{C} \times 65^\circ\text{C}$

b. D-grade:  $\pm 1.98\% = \pm 1.0\% \pm 150\ \text{ppm}/^\circ\text{C} \times 65^\circ\text{C}$

Example: The C-grade LM4040-2.5 has an overtemperature Reverse-Breakdown Voltage tolerance of  $\pm 2.5 \times 1.15\% = \pm 29\ \text{mV}$ .

## LM4041-1.2 ELECTRICAL CHARACTERISTICS (Note 1) (CONTINUED)

$T_A$  = Operating Temperature Range,  $T_A = T_J = -40^\circ\text{C}$  to  $+85^\circ\text{C}$ , unless noted.

Parameters	Sym.	Min.	Typ.	Max.	Units	Conditions
Reverse-Breakdown Voltage Change with Operating Current Change	$\Delta V_R/\Delta I_R$	—	0.7	2.0	mV	$I_{RMIN} \leq I_R \leq 1 \text{ mA}$ , $T_A = +25^\circ\text{C}$
		—	—	2.5		$I_{RMIN} \leq I_R \leq 1 \text{ mA}$
		—	2.5	8.0		$1 \text{ mA} \leq I_R \leq 12 \text{ mA}$ , $T_A = +25^\circ\text{C}$
		—	—	10.0		$1 \text{ mA} \leq I_R \leq 12 \text{ mA}$
Reverse Dynamic Impedance	$Z_R$	—	0.5	2.0	$\Omega$	$I_R = 1 \text{ mA}$ , $f = 120 \text{ Hz}$ , $I_{AC} = 0.1 I_R$ , $T_A = +25^\circ\text{C}$
Wideband Noise	$e_N$	—	20	—	$\mu\text{V}_{RMS}$	$I_R = 100 \mu\text{A}$ , $T_A = +25^\circ\text{C}$ , $10 \text{ Hz} \leq f \leq 10 \text{ kHz}$
Reverse-Breakdown Voltage Long-Term Stability	$\Delta V_R$	—	120	—	ppm	$t = 1000 \text{ hrs.}$ , $T_A = +25^\circ\text{C}$ $\pm 0.1^\circ\text{C}$ , $I_R = 100 \mu\text{A}$

**Note 1:** Specification for packaged product only.

**2:** The boldface (overtemperature) limit for Reverse-Breakdown Voltage Tolerance is defined as the room temperature Reverse-Breakdown Voltage Tolerance  $\pm[(\Delta V_R/\Delta T)(65^\circ\text{C})(V_R)]$ .  $\Delta V_R/\Delta T$  is the  $V_R$  temperature coefficient,  $65^\circ\text{C}$  is the temperature range from  $-40^\circ\text{C}$  to the reference point of  $25^\circ\text{C}$ , and  $V_R$  is the reverse-breakdown voltage. The total overtemperature tolerance for the different grades follows:

a. C-grade:  $\pm 1.15\% = \pm 0.5\% \pm 100 \text{ ppm}/^\circ\text{C} \times 65^\circ\text{C}$

b. D-grade:  $\pm 1.98\% = \pm 1.0\% \pm 150 \text{ ppm}/^\circ\text{C} \times 65^\circ\text{C}$

Example: The C-grade LM4040-2.5 has an overtemperature Reverse-Breakdown Voltage tolerance of  $\pm 2.5 \times 1.15\% = \pm 29 \text{ mV}$ .

# LM4040/LM4041

## LM4041-ADJ ELECTRICAL CHARACTERISTICS (Note 1)

$T_A$  = Operating Temperature Range,  $T_A = T_J = -40^\circ\text{C}$  to  $+85^\circ\text{C}$ , unless noted.

Parameters	Sym.	Min.	Typ.	Max.	Units	Conditions
<b>LM4041C</b>						
Reverse-Breakdown Voltage	$V_R$	—	1.233	—	V	$I_R = 100\ \mu\text{A}$ , $V_{\text{OUT}} = 5\text{V}$
Reverse-Breakdown Voltage Tolerance (Note 2)		—	—	$\pm 6.2$	mV	$I_R = 100\ \mu\text{A}$ , $T_A = +25^\circ\text{C}$
		—	—	$\pm 14$	mV	$I_R = 100\ \mu\text{A}$
Minimum Operating Current	$I_{\text{RMIN}}$	—	45	60	$\mu\text{A}$	$T_A = +25^\circ\text{C}$
		—	—	65		—
Reference Voltage Change with Operating Current	$\frac{\Delta V_{\text{REF}}}{\Delta I_R}$	—	0.7	1.5	mV	$I_{\text{RMIN}} \leq I_R \leq 1\ \text{mA}$ , $V_{\text{OUT}} \geq 1.6\text{V}$ (Note 3), $T_A = +25^\circ\text{C}$
		—	—	2.0		$I_{\text{RMIN}} \leq I_R \leq 1\ \text{mA}$ , $V_{\text{OUT}} \geq 1.6\text{V}$ (Note 3)
		—	2.0	4.0		$1\ \text{mA} \leq I_R \leq 12\ \text{mA}$ , $V_{\text{OUT}} \geq 1.6\text{V}$ (Note 3), $T_A = +25^\circ\text{C}$
		—	—	6.0		$1\ \text{mA} \leq I_R \leq 12\ \text{mA}$ , $V_{\text{OUT}} \geq 1.6\text{V}$ (Note 3)
Reference Voltage Change with Output Voltage Change	$\frac{\Delta V_{\text{REF}}}{\Delta V_O}$	—	-1.55	-2.0	mV/V	$I_R = 1\ \text{mA}$ , $T_A = +25^\circ\text{C}$
		—	—	-2.5		$I_R = 1\ \text{mA}$
Feedback Current	$I_{\text{FB}}$	—	60	100	nA	$T_A = +25^\circ\text{C}$
		—	—	120		—
Average Reference Voltage Temperature Coefficient	$\frac{\Delta V_{\text{REF}}}{\Delta T}$	—	$\pm 20$	—	ppm/ $^\circ\text{C}$	$V_{\text{OUT}} = 5\text{V}$ , $I_R = 10\ \text{mA}$ , $T_A = +25^\circ\text{C}$
		—	$\pm 15$	$\pm 100$		$V_{\text{OUT}} = 5\text{V}$ , $I_R = 1\ \text{mA}$
		—	$\pm 15$	—		$V_{\text{OUT}} = 5\text{V}$ , $I_R = 100\ \mu\text{A}$ , $T_A = +25^\circ\text{C}$
Dynamic Output Impedance	$Z_{\text{OUT}}$	—	0.3	—	$\Omega$	$I_R = 1\ \text{mA}$ , $f = 120\ \text{Hz}$ , $T_A = +25^\circ\text{C}$ , $I_{\text{AC}} = 0.1 I_R$ , $V_{\text{OUT}} = V_{\text{REF}}$
		—	—	2.0		$V_{\text{OUT}} = 10\text{V}$ , $T_A = +25^\circ\text{C}$
Wideband Noise	$e_N$	—	20	—	$\mu\text{V}_{\text{RMS}}$	$I_R = 100\ \mu\text{A}$ , $T_A = +25^\circ\text{C}$ , $10\ \text{Hz} \leq f \leq 10\ \text{kHz}$

**Note 1:** Specification for packaged product only.

**2:** The boldface (overtemperature) limit for Reverse-Breakdown Voltage Tolerance is defined as the room temperature Reverse-Breakdown Voltage Tolerance  $\pm[(\Delta V_R/\Delta T)(65^\circ\text{C})(V_R)]$ .  $\Delta V_R/\Delta T$  is the  $V_R$  temperature coefficient,  $65^\circ\text{C}$  is the temperature range from  $-40^\circ\text{C}$  to the reference point of  $25^\circ\text{C}$ , and  $V_R$  is the reverse-breakdown voltage. The total overtemperature tolerance for the different grades follows:

a. C-grade:  $\pm 1.15\% = \pm 0.5\% \pm 100\ \text{ppm}/^\circ\text{C} \times 65^\circ\text{C}$

b. D-grade:  $\pm 1.98\% = \pm 1.0\% \pm 150\ \text{ppm}/^\circ\text{C} \times 65^\circ\text{C}$

Example: The C-grade LM4040-2.5 has an overtemperature Reverse-Breakdown Voltage tolerance of  $\pm 2.5 \times 1.15\% = \pm 29\ \text{mV}$ .

**3:** When  $V_{\text{OUT}} \leq 1.6\text{V}$ , the LM4041-ADJ must operate at reduced  $I_R$ . This is caused by the series resistance of the die attach between the die (-) output and the package (-) output pin. See the Output Saturation curve in the [Typical Performance Curves](#) section.

## LM4041-ADJ ELECTRICAL CHARACTERISTICS (Note 1) (CONTINUED)

$T_A$  = Operating Temperature Range,  $T_A = T_J = -40^\circ\text{C}$  to  $+85^\circ\text{C}$ , unless noted.

Parameters	Sym.	Min.	Typ.	Max.	Units	Conditions
Reverse-Breakdown Voltage Long-Term Stability	$\Delta V_R$	—	120	—	ppm	$t = 1000$ hrs., $T_A = +25^\circ\text{C}$ $\pm 0.1^\circ\text{C}$ , $I_R = 100 \mu\text{A}$
<b>LM4041D</b>						
Reverse-Breakdown Voltage	$V_R$	—	1.233	—	V	$I_R = 100 \mu\text{A}$ , $V_{\text{OUT}} = 5\text{V}$
Reverse-Breakdown Voltage Tolerance (Note 2)		—	—	$\pm 12$	mV	$I_R = 100 \mu\text{A}$ , $T_A = +25^\circ\text{C}$
		—	—	$\pm 24$	mV	$I_R = 100 \mu\text{A}$
Minimum Operating Current	$I_{\text{RMIN}}$	—	45	65	$\mu\text{A}$	$T_A = +25^\circ\text{C}$
		—	—	70		—
Reference Voltage Change with Operating Current	$\Delta V_{\text{REF}} / \Delta I_R$	—	0.7	2.0	mV	$I_{\text{RMIN}} \leq I_R \leq 1 \text{ mA}$ , $V_{\text{OUT}} \geq 1.6\text{V}$ (Note 3), $T_A = +25^\circ\text{C}$
		—	—	2.5		$I_{\text{RMIN}} \leq I_R \leq 1 \text{ mA}$ , $V_{\text{OUT}} \geq 1.6\text{V}$ (Note 3)
		—	2.0	6.0		$1 \text{ mA} \leq I_R \leq 12 \text{ mA}$ , $V_{\text{OUT}} \geq 1.6\text{V}$ (Note 3), $T_A = +25^\circ\text{C}$
		—	—	8.0		$1 \text{ mA} \leq I_R \leq 12 \text{ mA}$ , $V_{\text{OUT}} \geq 1.6\text{V}$ (Note 3)
Reference Voltage Change with Output Voltage Change	$\Delta V_{\text{REF}} / \Delta V_O$	—	-1.55	-2.5	mV/V	$I_R = 1 \text{ mA}$ , $T_A = +25^\circ\text{C}$
		—	—	-3.0		$I_R = 1 \text{ mA}$
Feedback Current	$I_{\text{FB}}$	—	60	150	nA	$T_A = +25^\circ\text{C}$
		—	—	200		—
Average Reference Voltage Temperature Coefficient	$\Delta V_{\text{REF}} / \Delta T$	—	$\pm 20$	—	ppm/ $^\circ\text{C}$	$V_{\text{OUT}} = 5\text{V}$ , $I_R = 10 \text{ mA}$ , $T_A = +25^\circ\text{C}$
		—	$\pm 15$	$\pm 150$		$V_{\text{OUT}} = 5\text{V}$ , $I_R = 1 \text{ mA}$
		—	$\pm 15$	—		$V_{\text{OUT}} = 5\text{V}$ , $I_R = 100 \mu\text{A}$ , $T_A = +25^\circ\text{C}$
Dynamic Output Impedance	$Z_{\text{OUT}}$	—	0.3	—	$\Omega$	$I_R = 1 \text{ mA}$ , $f = 120 \text{ Hz}$ , $T_A = +25^\circ\text{C}$ , $I_{\text{AC}} = 0.1 I_R$ , $V_{\text{OUT}} = V_{\text{REF}}$
		—	—	2.0		$V_{\text{OUT}} = 10\text{V}$ , $T_A = +25^\circ\text{C}$

**Note 1:** Specification for packaged product only.

- 2:** The boldface (overtemperature) limit for Reverse-Breakdown Voltage Tolerance is defined as the room temperature Reverse-Breakdown Voltage Tolerance  $\pm[(\Delta V_R / \Delta T)(65^\circ\text{C})(V_R)]$ .  $\Delta V_R / \Delta T$  is the  $V_R$  temperature coefficient,  $65^\circ\text{C}$  is the temperature range from  $-40^\circ\text{C}$  to the reference point of  $25^\circ\text{C}$ , and  $V_R$  is the reverse-breakdown voltage. The total overtemperature tolerance for the different grades follows:

- C-grade:  $\pm 1.15\% = \pm 0.5\% \pm 100 \text{ ppm}/^\circ\text{C} \times 65^\circ\text{C}$
- D-grade:  $\pm 1.98\% = \pm 1.0\% \pm 150 \text{ ppm}/^\circ\text{C} \times 65^\circ\text{C}$

Example: The C-grade LM4040-2.5 has an overtemperature Reverse-Breakdown Voltage tolerance of  $\pm 2.5 \times 1.15\% = \pm 29 \text{ mV}$ .

- 3:** When  $V_{\text{OUT}} \leq 1.6\text{V}$ , the LM4041-ADJ must operate at reduced  $I_R$ . This is caused by the series resistance of the die attach between the die (-) output and the package (-) output pin. See the Output Saturation curve in the [Typical Performance Curves](#) section.

# LM4040/LM4041

## LM4041-ADJ ELECTRICAL CHARACTERISTICS (Note 1) (CONTINUED)

$T_A$  = Operating Temperature Range,  $T_A = T_J = -40^\circ\text{C}$  to  $+85^\circ\text{C}$ , unless noted.

Parameters	Sym.	Min.	Typ.	Max.	Units	Conditions
Wideband Noise	$e_N$	—	20	—	$\mu\text{V}_{\text{RMS}}$	$I_R = 100\ \mu\text{A}$ , $T_A = +25^\circ\text{C}$ , $10\ \text{Hz} \leq f \leq 10\ \text{kHz}$
Reverse-Breakdown Voltage Long-Term Stability	$\Delta V_R$	—	120	—	ppm	$t = 1000\ \text{hrs.}$ , $T_A = +25^\circ\text{C}$ $\pm 0.1^\circ\text{C}$ , $I_R = 100\ \mu\text{A}$

**Note 1:** Specification for packaged product only.

**2:** The boldface (overtemperature) limit for Reverse-Breakdown Voltage Tolerance is defined as the room temperature Reverse-Breakdown Voltage Tolerance  $\pm[(\Delta V_R/\Delta T)(65^\circ\text{C})(V_R)]$ .  $\Delta V_R/\Delta T$  is the  $V_R$  temperature coefficient,  $65^\circ\text{C}$  is the temperature range from  $-40^\circ\text{C}$  to the reference point of  $25^\circ\text{C}$ , and  $V_R$  is the reverse-breakdown voltage. The total overtemperature tolerance for the different grades follows:

a. C-grade:  $\pm 1.15\% = \pm 0.5\% \pm 100\ \text{ppm}/^\circ\text{C} \times 65^\circ\text{C}$

b. D-grade:  $\pm 1.98\% = \pm 1.0\% \pm 150\ \text{ppm}/^\circ\text{C} \times 65^\circ\text{C}$

Example: The C-grade LM4040-2.5 has an overtemperature Reverse-Breakdown Voltage tolerance of  $\pm 2.5 \times 1.15\% = \pm 29\ \text{mV}$ .

**3:** When  $V_{\text{OUT}} \leq 1.6\text{V}$ , the LM4041-ADJ must operate at reduced  $I_R$ . This is caused by the series resistance of the die attach between the die (-) output and the package (-) output pin. See the Output Saturation curve in the [Typical Performance Curves](#) section.

## TEMPERATURE SPECIFICATIONS (Note 1)

Parameters	Sym.	Min.	Typ.	Max.	Units	Conditions
<b>Temperature Ranges</b>						
Operating Temperature Range	$T_A$	-40	—	+85	°C	—
Storage Temperature	$T_S$	-65	—	+150	°C	—
Lead Temperature	—	—	+215	—	°C	Vapor phase, 60s
Lead Temperature	—	—	+220	—	°C	Infrared, 15s
<b>Package Thermal Resistance</b>						
3-Pin SOT-23	$\theta_{JA}$	—	+326	—	°C/W	—

**Note 1:** The maximum allowable power dissipation is a function of ambient temperature, the maximum allowable junction temperature and the thermal resistance from junction to air (i.e.,  $T_A$ ,  $T_J$ ,  $\theta_{JA}$ ). Exceeding the maximum allowable power dissipation will cause the device operating junction temperature to exceed the maximum +125°C rating. Sustained junction temperatures above +125°C can impact the device reliability.

## Test Circuits

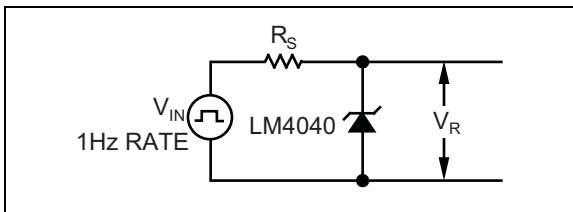

**FIGURE 1-1:** LM4040.

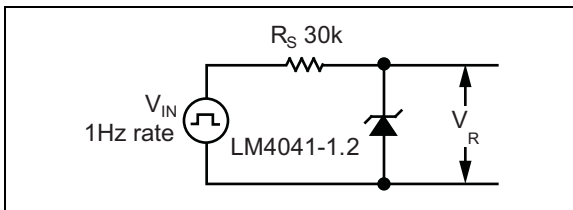

**FIGURE 1-2:** LM4041.

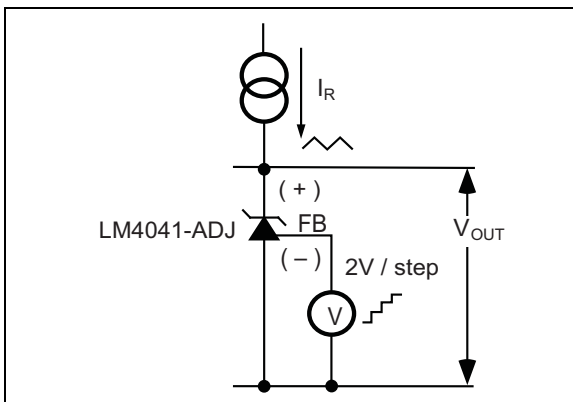

**FIGURE 1-3:** Reverse Characteristics Test Circuit.

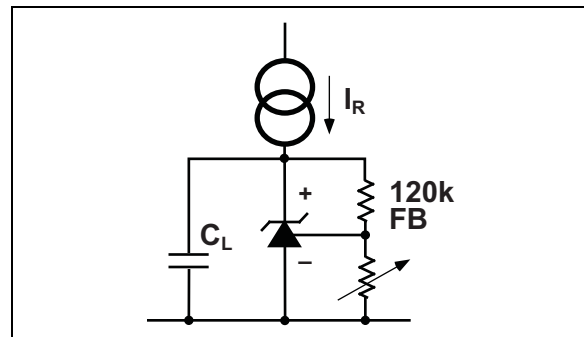

**FIGURE 1-4:** Output Impedance vs. Frequency Test Circuit.

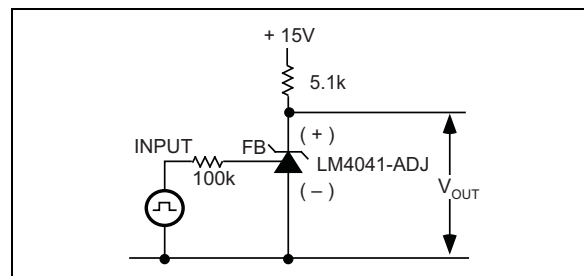
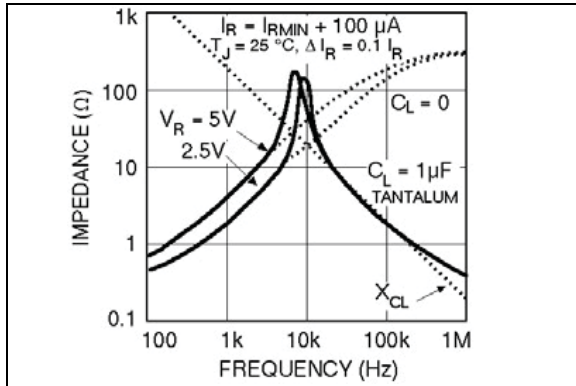

**FIGURE 1-5:** Large Signal Response Test Circuit.

# LM4040/LM4041

## 2.0 TYPICAL PERFORMANCE CURVES

**Note:** The graphs and tables provided following this note are a statistical summary based on a limited number of samples and are provided for informational purposes only. The performance characteristics listed herein are not tested or guaranteed. In some graphs or tables, the data presented may be outside the specified operating range (e.g., outside specified power supply range) and therefore outside the warranted range.



**FIGURE 2-1:** LM4040 Output Impedance vs. Frequency.

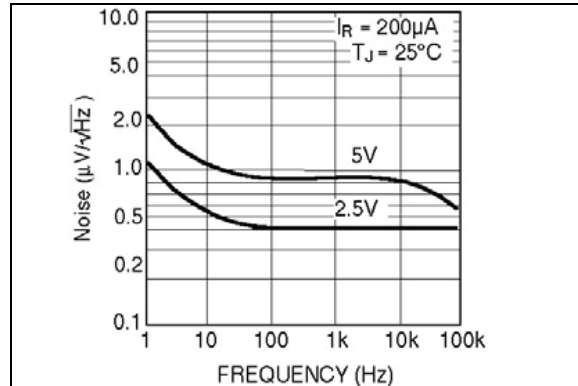

**FIGURE 2-4:** LM4040 Noise Voltage vs. Frequency.

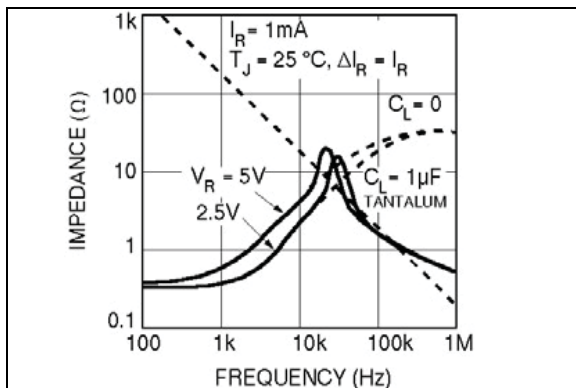

**FIGURE 2-2:** LM4040 Output Impedance vs. Frequency.

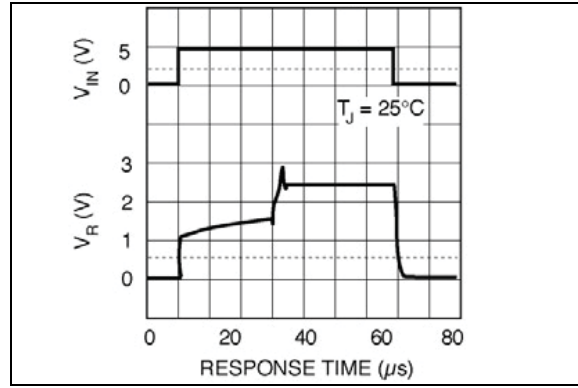

**FIGURE 2-5:** LM4040-2.5 Start-Up Characteristics ( $R_S = 30 \text{ k}\Omega$ ).

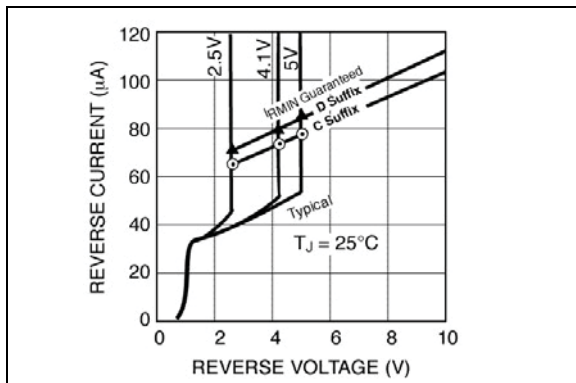

**FIGURE 2-3:** LM4040 Reverse Characteristics and Minimum Operating Current.

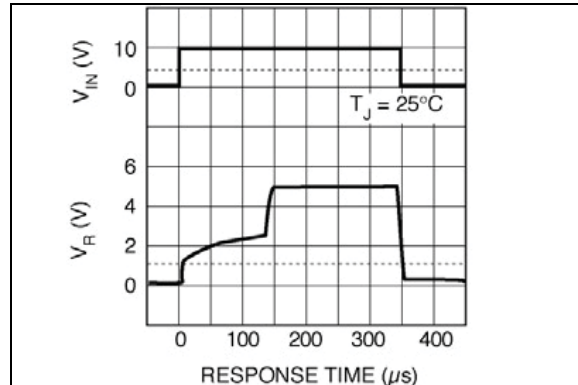

**FIGURE 2-6:** LM4040-5.0 Start-Up Characteristics ( $R_S = 30 \text{ k}\Omega$ ).

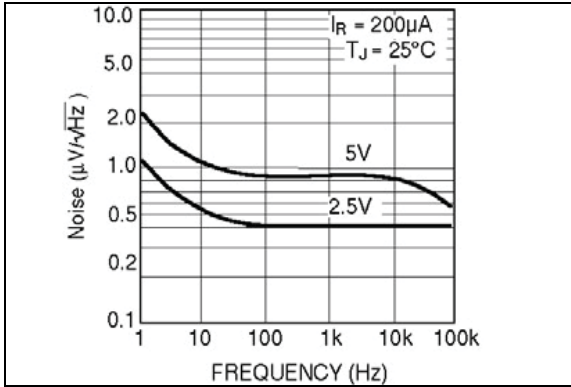

**FIGURE 2-7:** LM4041 Noise Voltage vs. Frequency.

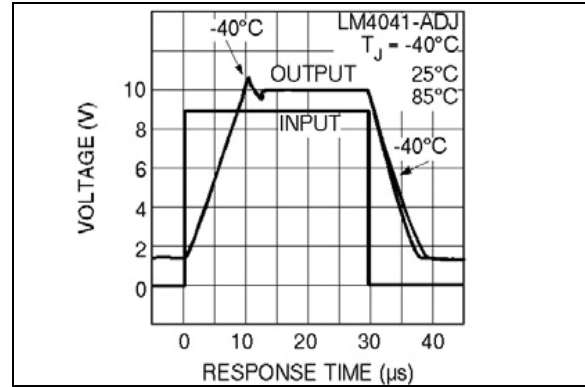

**FIGURE 2-10:** LM4041 Large Signal Response.

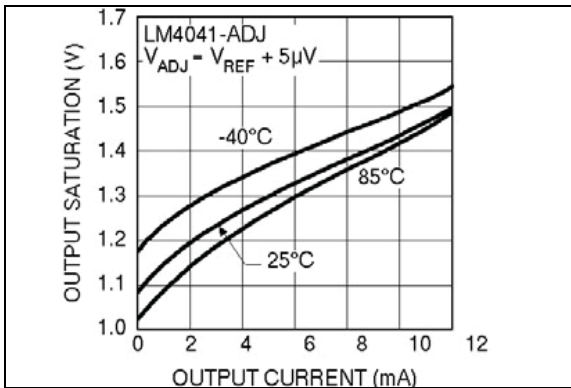

**FIGURE 2-8:** LM4041 Output Saturation.

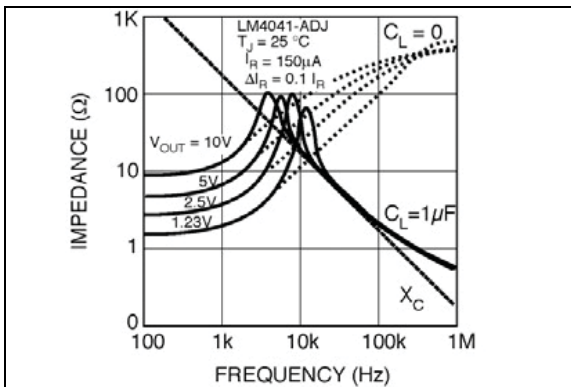

**FIGURE 2-9:** LM4041 Output Impedance vs. Frequency.

# LM4040/LM4041

---

## 3.0 PIN DESCRIPTIONS

The descriptions of the pins are listed in [Table 3-1](#).

**TABLE 3-1: PIN FUNCTION TABLE**

Pin Number Fixed	Pin Number Adjustable	Pin Name	Description
1	2	+	Cathode. Connect to positive voltage.
—	1	FB	Feedback. Connect to a resistive divider network to set the output voltage.
2	3	–	Anode. Connect to negative voltage.
3	—	NC	Not internally connected. This pin must be left floating or connected to –.

## 4.0 APPLICATION INFORMATION

The stable operation of the LM4040 and LM4041 references require an external capacitor greater than 10 nF connected between the (+) and (-) pins. Bypass capacitors with values between 100 pF and 10 nF have been found to cause the devices to exhibit instabilities.

### 4.1 Schottky Diode

LM4040-x.x and LM4041-1.2 in the SOT-23 package have a parasitic Schottky diode between Pin 2 (-) and Pin 3 (die attach interface connect). Pin 3 of the SOT-23 package must float or be connected to Pin 2. The LM4041-ADJ use Pin 3 as the (-) output.

### 4.2 Conventional Shunt Regulator

In a conventional shunt regulator application (see [Figure 5-1](#)), an external series resistor ( $R_S$ ) is connected between the supply voltage and the LM4040-x.x or LM4041-1.2 reference.  $R_S$  determines the current that flows through the load ( $I_L$ ) and the reference ( $I_Q$ ). Because load current and supply voltage may vary,  $R_S$  should be small enough to supply at least the minimum acceptable  $I_Q$  to the reference even when the supply voltage is at its minimum and the load current is at its maximum value. When the supply voltage is at its maximum and  $I_L$  is at its minimum,  $R_S$  should be large enough so that the current flowing through the LM4040-x.x is less than 15 mA, and the current flowing through the LM4041-1.2 or LM4041-ADJ is less than 12 mA.

$R_S$  is determined by the supply voltage ( $V_S$ ), the load and operating current, ( $I_L$  and  $I_Q$ ), and the reference's reverse breakdown voltage ( $V_R$ ):

**EQUATION 4-1:**

$$R_S = \frac{(V_S - V_R)}{(I_L + I_Q)}$$

### 4.3 Adjustable Regulator

The LM4041-ADJ's output voltage can be adjusted to any value between 1.24V and 10V. It is a function of the internal reference voltage ( $V_{REF}$ ) and the ratio of the external feedback resistors as shown in [Figure 5-2](#). The output is found using the following equation:

**EQUATION 4-2:**

$$V_O = V_{REF}[(R2/R1) + 1]$$

Where:

$V_O$  Desired Output Voltage

The actual value of the internal  $V_{REF}$  is a function of  $V_O$ . The corrected  $V_{REF}$  is determined by:

**EQUATION 4-3:**

$$V_{REF} = V_O \times \left( \frac{\Delta V_{REF}}{\Delta V_O} \right) + V_Y$$

Where:

$V_O$  Desired Output Voltage

$\Delta V_{REF}/\Delta V_O$  is found in the Electrical Characteristics section and is typically  $-1.3$  mV/V and  $V_Y$  is equal to 1.233V. Replace the value of  $V_{REF}$  in [Equation 4-2](#) with the value  $V_{REF}$  found using [Equation 4-3](#).

Note that actual output voltage can deviate from that predicted using the typical  $\Delta V_{REF}/\Delta V_O$  in [Equation 4-3](#); for C-grade parts, the worst case  $\Delta V_{REF}/\Delta V_O$  is  $-2.5$  mV/V and  $V_Y = 1.248$ V.

The following example shows the difference in output voltage resulting from the typical and worst case values of  $\Delta V_{REF}/\Delta V_O$ .

Let  $V_O = +9$ V. Using the typical values of  $\Delta V_{REF}/\Delta V_O$ ,  $V_{REF}$  is 1.223V. Choosing a value of  $R1 = 10$  k $\Omega$ ,  $R2 = 63.272$  k $\Omega$ . Using the worst case  $\Delta V_{REF}/\Delta V_O$  for the C-grade and D-grade parts, the output voltage is actually 8.965V and 8.946V respectively. This results in possible errors as large as 0.39% for the C-grade parts and 0.59% for the D-grade parts. Once again, resistor values found using the typical value of  $\Delta V_{REF}/\Delta V_O$  will work in most cases, requiring no further adjustment.

# LM4040/LM4041

## 5.0 TYPICAL APPLICATION CIRCUITS

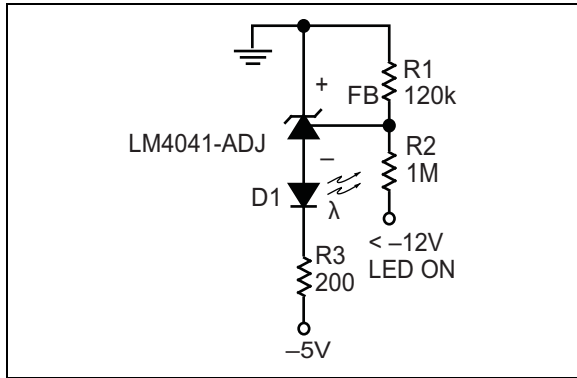

**FIGURE 5-1:** Voltage Level Detector.

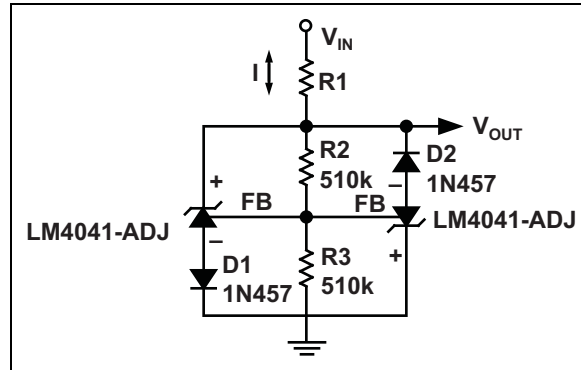

**FIGURE 5-4:** Bidirectional Clamp  $\pm 2.4V$ .

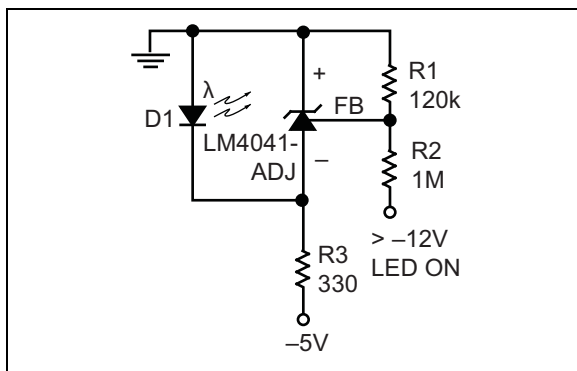

**FIGURE 5-2:** Voltage Level Detector.

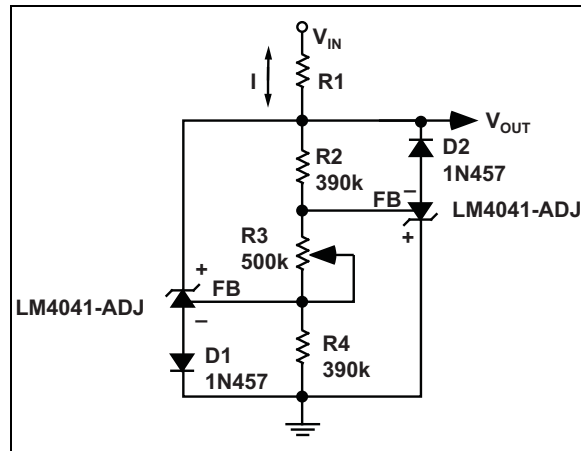

**FIGURE 5-5:** Bidirectional Adjustable Clamp  $\pm 1.8V$  to  $\pm 2.4V$ .

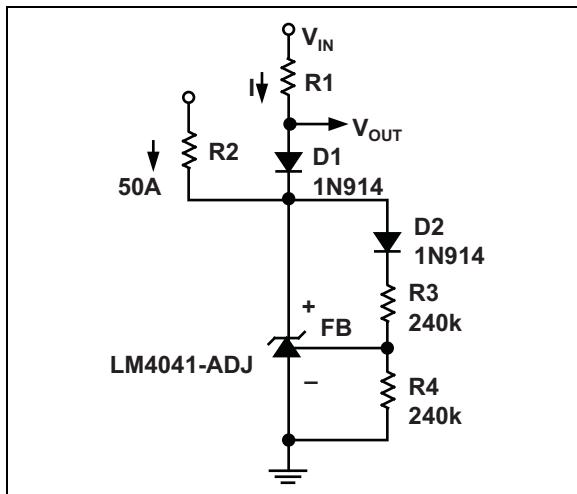

**FIGURE 5-3:** Fast Positive Clamp,  $2.4V + \Delta V_{D1}$ .

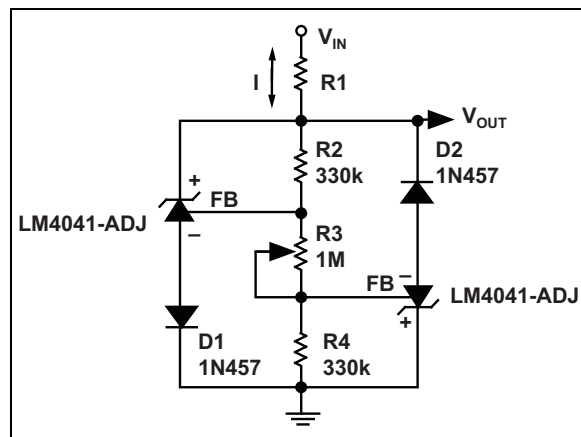

**FIGURE 5-6:** Bidirectional Adjustable Clamp  $\pm 2.4V$  to  $\pm 6V$ .

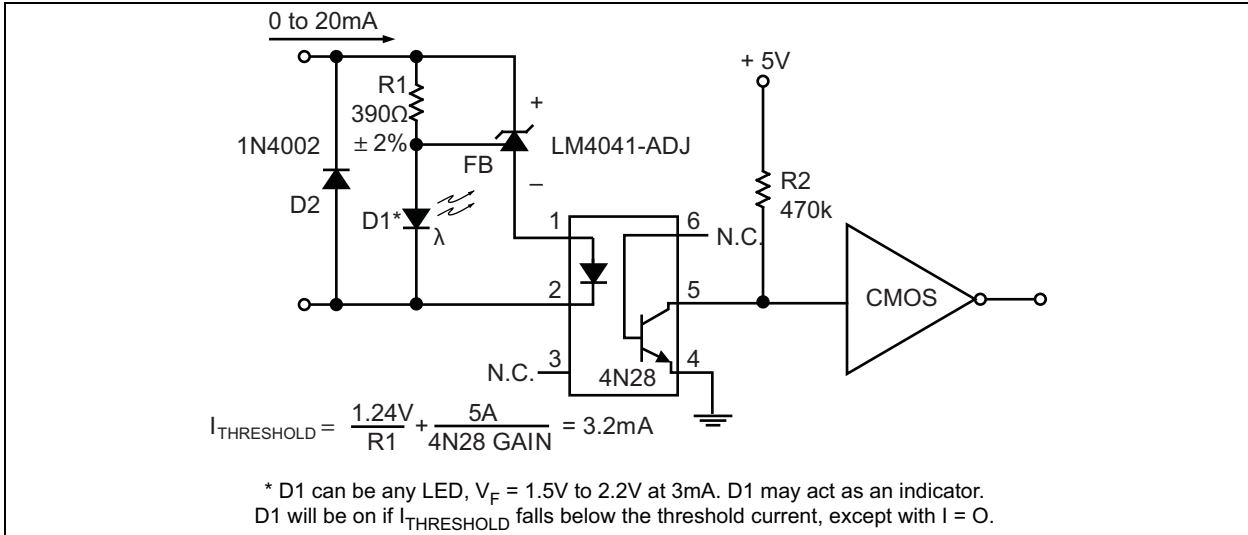

**FIGURE 5-7:** Floating Current Detector.

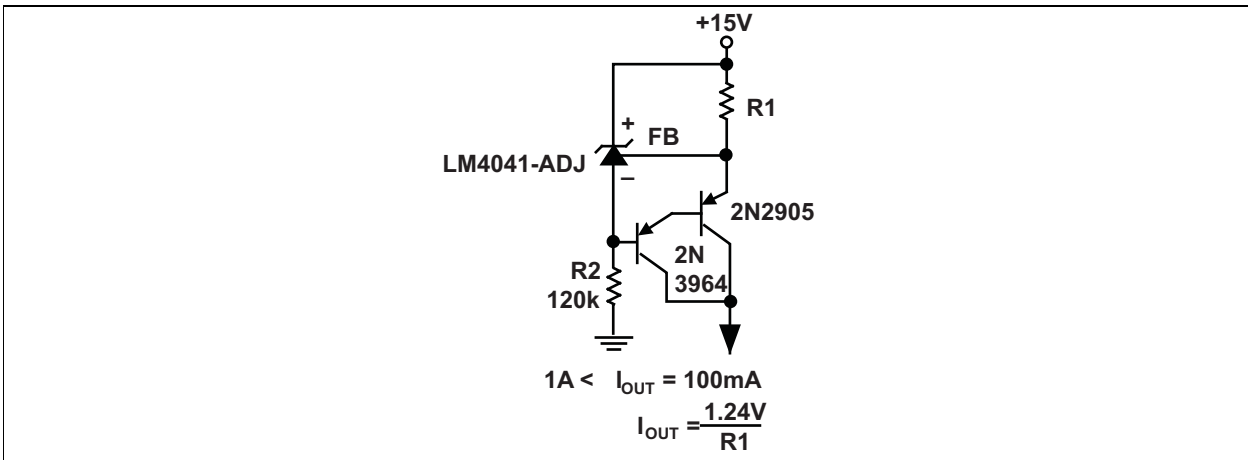

**FIGURE 5-8:** Current Source.

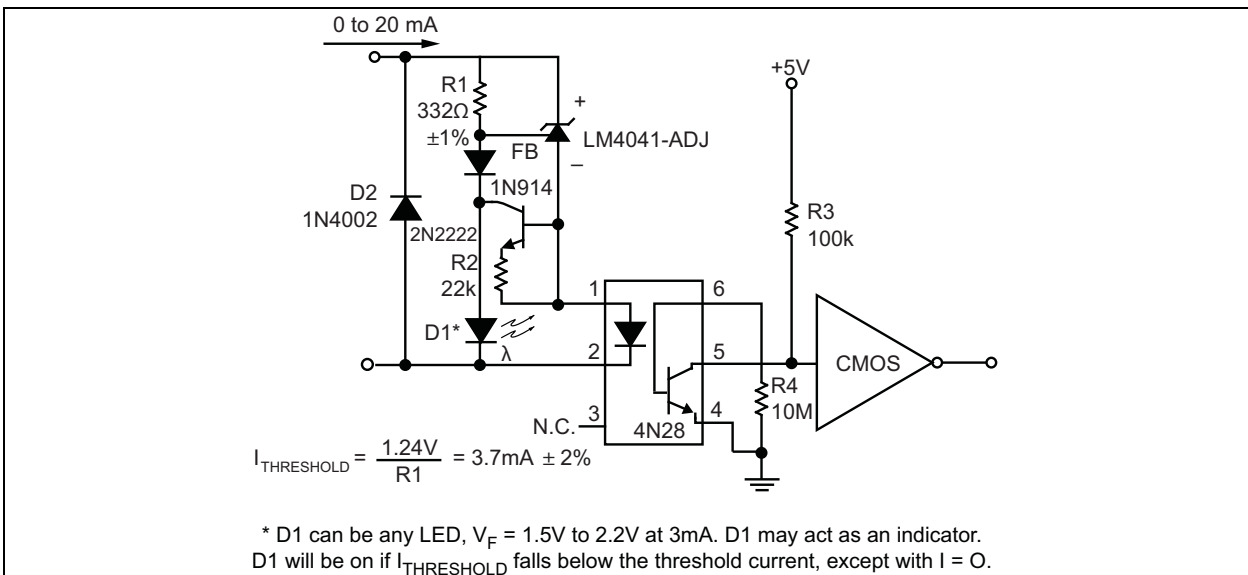

**FIGURE 5-9:** Precision Floating Current Detector.

# LM4040/LM4041

## 6.0 PACKAGING INFORMATION

### 6.1 Package Marking Information

#### 3-Pin SOT-23\*

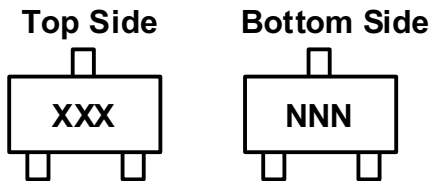

#### Example

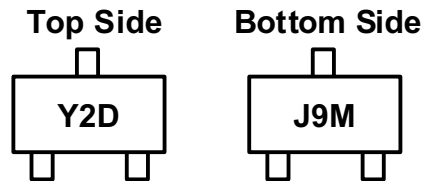

Device	Top Side Marking
LM4040CYM3-2.5-TR	Y2C
LM4040CYM3-4.1-TR	Y4C
LM4040CYM3-5.0-TR	Y5C
LM4040DYM3-2.5-TR	Y2D
LM4040DYM3-4.1-TR	Y4D
LM4040DYM3-5.0-TR	Y5D
LM4041CYM3-ADJ-TR	YAC
LM4041CYM3-1.2-TR	Y1C
LM4041DYM3-ADJ-TR	YAD
LM4041DYM3-1.2-TR	Y1D

<b>Legend:</b>	XX...X	Product code or customer-specific information
	Y	Year code (last digit of calendar year)
	YY	Year code (last 2 digits of calendar year)
	WW	Week code (week of January 1 is week '01')
	NNN	Alphanumeric traceability code
	(e3)	Pb-free JEDEC® designator for Matte Tin (Sn)
	*	This package is Pb-free. The Pb-free JEDEC designator ((e3)) can be found on the outer packaging for this package.
	•, ▲, ▼	Pin one index is identified by a dot, delta up, or delta down (triangle mark).

**Note:** In the event the full Microchip part number cannot be marked on one line, it will be carried over to the next line, thus limiting the number of available characters for customer-specific information. Package may or may not include the corporate logo.

Underbar ( ) and/or Overbar ( ) symbol may not be to scale.

## 3-Lead SOT-23 Package Outline and Recommended Land Pattern

**TITLE**

3 LEAD SOT23 PACKAGE OUTLINE & RECOMMENDED LAND PATTERN

<b>DRAWING #</b>	SOT23-3LD-PL-1	<b>UNIT</b>	MM
------------------	----------------	-------------	----

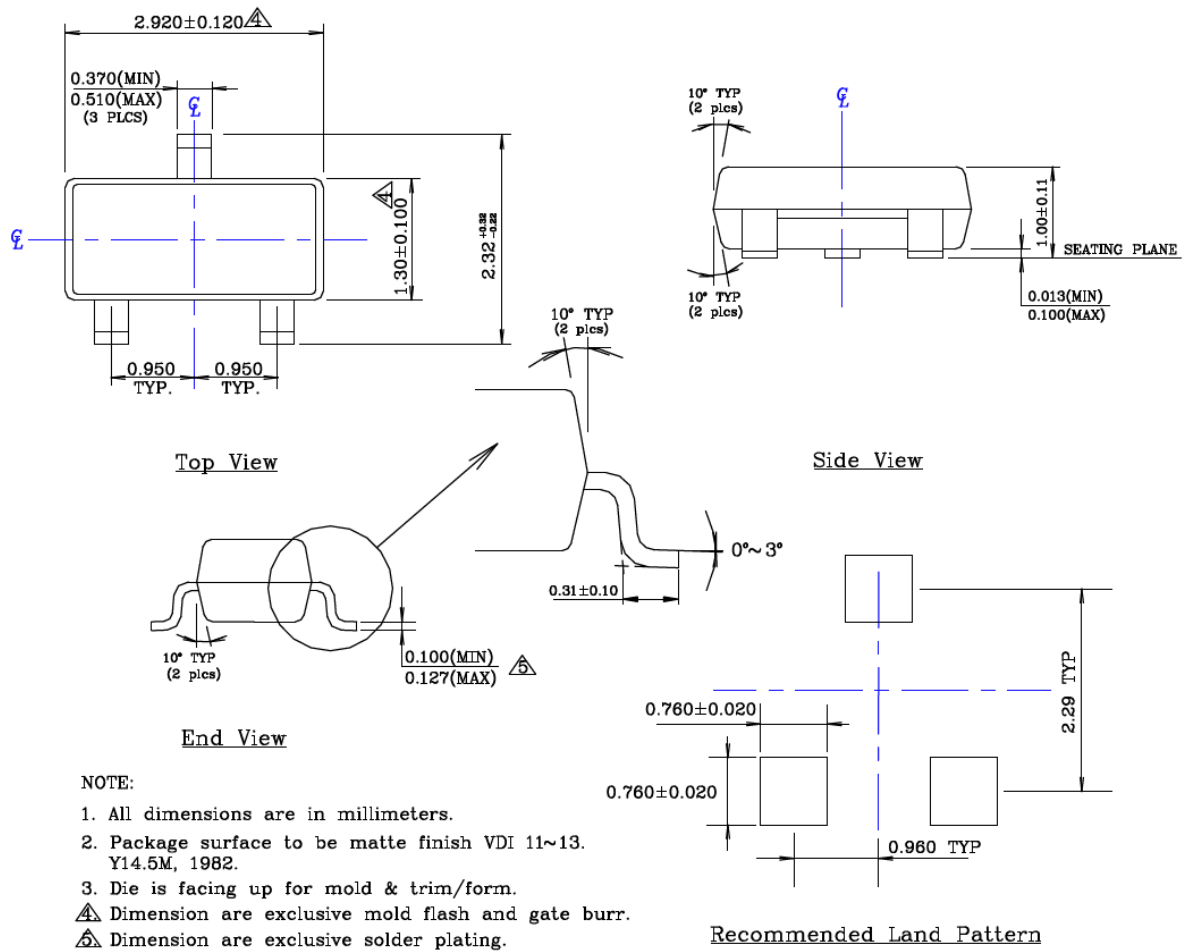

**NOTE:**

- All dimensions are in millimeters.
- Package surface to be matte finish VDI 11~13. Y14.5M, 1982.
- Die is facing up for mold & trim/form.
- $\triangle$  Dimension are exclusive mold flash and gate burr.
- $\triangle$  Dimension are exclusive solder plating.

Note: For the most current package drawings, please see the Microchip Packaging Specification located at <http://www.microchip.com/packaging>.

# LM4040/LM4041

---

NOTES:

## APPENDIX A: REVISION HISTORY

### Revision A (April 2017)

- Converted Micrel data sheet LM4040/LM4041 to Microchip DS20005757A.
- Minor text changes throughout.
- Updated temperature information in all Electrical Characteristics tables to better reflect which values are valid for  $T_A = +25^\circ\text{C}$ .

### Revision B (July 2018)

- Corrected part number for Reverse Current in [Operating Ratings](#) ‡ to LM4041-ADJ.
- Updated [Section 6.1 “Package Marking Information”](#) drawing and information.
- Updated information in [Product Identification System](#).
- Updated “Reverse-Breakdown Voltage Change with Operating Current Change” conditions for [LM4041-1.2 Electrical Characteristics \(Note 1\)](#) and [LM4041-ADJ Electrical Characteristics \(Note 1\)](#).

# LM4040/LM4041

---

NOTES:

## PRODUCT IDENTIFICATION SYSTEM

To order or obtain information, e.g., on pricing or delivery, contact your local Microchip representative or sales office.

<u>PART NO.</u>	<u>X</u>	<u>X</u>	<u>XX</u>	<u>-X,X</u>	<u>-XX</u>	<b>Examples:</b>
Device	Accuracy, Temperature Coefficient	Temperature Range	Package	Voltage	Media Type	
<b>Device:</b>	LM4040:	Precision Micropower Shunt Voltage Reference				a) LM4040CYM3-2.5-TR: LM4040, $\pm 0.5\%$ , 100 ppm/ $^{\circ}\text{C}$ , $-40^{\circ}\text{C}$ to $+85^{\circ}\text{C}$ Temp. Range, 3-Lead SOT-23, 2.500V, 3,000/Reel
	LM4041:	Precision Micropower Shunt Voltage Reference				b) LM4040CYM3-4.1-TR: LM4040, $\pm 0.5\%$ , 100 ppm/ $^{\circ}\text{C}$ , $-40^{\circ}\text{C}$ to $+85^{\circ}\text{C}$ Temp. Range, 3-Lead SOT-23, 4.096V, 3,000/Reel
<b>Accuracy, Temp. Coefficient:</b>	C	= $\pm 0.5\%$ , 100 ppm/ $^{\circ}\text{C}$				c) LM4040CYM3-5.0-TR: LM4040, $\pm 0.5\%$ , 100 ppm/ $^{\circ}\text{C}$ , $-40^{\circ}\text{C}$ to $+85^{\circ}\text{C}$ Temp. Range, 3-Lead SOT-23, 5.000V, 3,000/Reel
	D	= $\pm 1.0\%$ , 150 ppm/ $^{\circ}\text{C}$				d) LM4040DYM3-2.5-TR: LM4040, $\pm 1.0\%$ , 150 ppm/ $^{\circ}\text{C}$ , $-40^{\circ}\text{C}$ to $+85^{\circ}\text{C}$ Temp. Range, 3-Lead SOT-23, 2.500V, 3,000/Reel
<b>Temperature Range:</b>	Y	= $-40^{\circ}\text{C}$ to $+85^{\circ}\text{C}$ (Industrial)				e) LM4040DYM3-4.1-TR: LM4040, $\pm 1.0\%$ , 150 ppm/ $^{\circ}\text{C}$ , $-40^{\circ}\text{C}$ to $+85^{\circ}\text{C}$ Temp. Range, 3-Lead SOT-23, 4.096V, 3,000/Reel
<b>Package:</b>	M3	= 3-Lead SOT-23				f) LM4040DYM3-5.0-TR: LM4040, $\pm 1.0\%$ , 150 ppm/ $^{\circ}\text{C}$ , $-40^{\circ}\text{C}$ to $+85^{\circ}\text{C}$ Temp. Range, 3-Lead SOT-23, 5.000V, 3,000/Reel
<b>Voltage:</b>	-2.5	= 2.500V				g) LM4041CYM3-ADJ-TR: LM4041, $\pm 0.5\%$ , 100 ppm/ $^{\circ}\text{C}$ , $-40^{\circ}\text{C}$ to $+85^{\circ}\text{C}$ Temp. Range, 3-Lead SOT-23, 1.24V to 10V, 3,000/Reel
	-4.1	= 4.096V				h) LM4041CYM3-1.2-TR: LM4041, $\pm 0.5\%$ , 100 ppm/ $^{\circ}\text{C}$ , $-40^{\circ}\text{C}$ to $+85^{\circ}\text{C}$ Temp. Range, 3-Lead SOT-23, 1.225V, 3,000/Reel
	-5.0	= 5.000V				i) LM4041DYM3-ADJ-TR: LM4041, $\pm 1.0\%$ , 150 ppm/ $^{\circ}\text{C}$ , $-40^{\circ}\text{C}$ to $+85^{\circ}\text{C}$ Temp. Range, 3-Lead SOT-23, 1.24V to 10V, 3,000/Reel
	-1.2	= 1.225V (LM4041 Only)				j) LM4041DYM3-1.2-TR: LM4041, $\pm 1.0\%$ , 150 ppm/ $^{\circ}\text{C}$ , $-40^{\circ}\text{C}$ to $+85^{\circ}\text{C}$ Temp. Range, 3-Lead SOT-23, 1.225V, 3,000/Reel
	ADJ	= 1.24V to 10V (LM4041 Only)				
<b>Media Type</b>	TR	= 3,000/Reel				<b>Note 1:</b> Tape and Reel identifier only appears in the catalog part number description. This identifier is used for ordering purposes and is not printed on the device package. Check with your Microchip Sales Office for package availability with the Tape and Reel option.

# LM4040/LM4041

---

NOTES:

---

---

**Note the following details of the code protection feature on Microchip devices:**

- Microchip products meet the specification contained in their particular Microchip Data Sheet.
- Microchip believes that its family of products is one of the most secure families of its kind on the market today, when used in the intended manner and under normal conditions.
- There are dishonest and possibly illegal methods used to breach the code protection feature. All of these methods, to our knowledge, require using the Microchip products in a manner outside the operating specifications contained in Microchip's Data Sheets. Most likely, the person doing so is engaged in theft of intellectual property.
- Microchip is willing to work with the customer who is concerned about the integrity of their code.
- Neither Microchip nor any other semiconductor manufacturer can guarantee the security of their code. Code protection does not mean that we are guaranteeing the product as “unbreakable.”

Code protection is constantly evolving. We at Microchip are committed to continuously improving the code protection features of our products. Attempts to break Microchip's code protection feature may be a violation of the Digital Millennium Copyright Act. If such acts allow unauthorized access to your software or other copyrighted work, you may have a right to sue for relief under that Act.

---

Information contained in this publication regarding device applications and the like is provided only for your convenience and may be superseded by updates. It is your responsibility to ensure that your application meets with your specifications. MICROCHIP MAKES NO REPRESENTATIONS OR WARRANTIES OF ANY KIND WHETHER EXPRESS OR IMPLIED, WRITTEN OR ORAL, STATUTORY OR OTHERWISE, RELATED TO THE INFORMATION, INCLUDING BUT NOT LIMITED TO ITS CONDITION, QUALITY, PERFORMANCE, MERCHANTABILITY OR FITNESS FOR PURPOSE. Microchip disclaims all liability arising from this information and its use. Use of Microchip devices in life support and/or safety applications is entirely at the buyer's risk, and the buyer agrees to defend, indemnify and hold harmless Microchip from any and all damages, claims, suits, or expenses resulting from such use. No licenses are conveyed, implicitly or otherwise, under any Microchip intellectual property rights unless otherwise stated.

*Microchip received ISO/TS-16949:2009 certification for its worldwide headquarters, design and wafer fabrication facilities in Chandler and Tempe, Arizona; Gresham, Oregon and design centers in California and India. The Company's quality system processes and procedures are for its PIC® MCUs and dsPIC® DSCs, KEELOQ® code hopping devices, Serial EEPROMs, microperipherals, nonvolatile memory and analog products. In addition, Microchip's quality system for the design and manufacture of development systems is ISO 9001:2000 certified.*

**QUALITY MANAGEMENT SYSTEM  
CERTIFIED BY DNV  
= ISO/TS 16949 =**

### Trademarks

The Microchip name and logo, the Microchip logo, AnyRate, AVR, AVR logo, AVR Freaks, BitCloud, chipKIT, chipKIT logo, CryptoMemory, CryptoRF, dsPIC, FlashFlex, flexPWR, Heldo, JukeBlox, KeeLoq, Klear, LANCheck, LINK MD, maXStylus, maXTouch, MediaLB, megaAVR, MOST, MOST logo, MPLAB, OptoLyzer, PIC, picoPower, PICSTART, PIC32 logo, Prochip Designer, QTouch, SAM-BA, SpyNIC, SST, SST Logo, SuperFlash, tinyAVR, UNI/O, and XMEGA are registered trademarks of Microchip Technology Incorporated in the U.S.A. and other countries.

ClockWorks, The Embedded Control Solutions Company, EtherSynch, Hyper Speed Control, HyperLight Load, IntellIMOS, mTouch, Precision Edge, and Quiet-Wire are registered trademarks of Microchip Technology Incorporated in the U.S.A.

Adjacent Key Suppression, AKS, Analog-for-the-Digital Age, Any Capacitor, AnyIn, AnyOut, BodyCom, CodeGuard, CryptoAuthentication, CryptoAutomotive, CryptoCompanion, CryptoController, dsPICDEM, dsPICDEM.net, Dynamic Average Matching, DAM, ECAN, EtherGREEN, In-Circuit Serial Programming, ICSP, INICnet, Inter-Chip Connectivity, JitterBlocker, KlearNet, KlearNet logo, memBrain, Mindi, MiWi, motorBench, MPASM, MPF, MPLAB Certified logo, MPLIB, MPLINK, MultiTRAK, NetDetach, Omniscient Code Generation, PICDEM, PICDEM.net, PICKit, PICtail, PowerSmart, PureSilicon, QMatrix, REAL ICE, Ripple Blocker, SAM-ICE, Serial Quad I/O, SMART-I.S., SQI, SuperSwitcher, SuperSwitcher II, Total Endurance, TSHARC, USBCheck, VariSense, ViewSpan, WiperLock, Wireless DNA, and ZENA are trademarks of Microchip Technology Incorporated in the U.S.A. and other countries.

SQTP is a service mark of Microchip Technology Incorporated in the U.S.A.

Silicon Storage Technology is a registered trademark of Microchip Technology Inc. in other countries.

GestIC is a registered trademark of Microchip Technology Germany II GmbH & Co. KG, a subsidiary of Microchip Technology Inc., in other countries.

All other trademarks mentioned herein are property of their respective companies.

© 2017-2018, Microchip Technology Incorporated, All Rights Reserved.

ISBN: 978-1-5224-3309-5



# MICROCHIP

## Worldwide Sales and Service

### AMERICAS

**Corporate Office**  
2355 West Chandler Blvd.  
Chandler, AZ 85224-6199  
Tel: 480-792-7200  
Fax: 480-792-7277  
Technical Support:  
<http://www.microchip.com/support>  
Web Address:  
[www.microchip.com](http://www.microchip.com)

**Atlanta**  
Duluth, GA  
Tel: 678-957-9614  
Fax: 678-957-1455

**Austin, TX**  
Tel: 512-257-3370

**Boston**  
Westborough, MA  
Tel: 774-760-0087  
Fax: 774-760-0088

**Chicago**  
Itasca, IL  
Tel: 630-285-0071  
Fax: 630-285-0075

**Dallas**  
Addison, TX  
Tel: 972-818-7423  
Fax: 972-818-2924

**Detroit**  
Novi, MI  
Tel: 248-848-4000

**Houston, TX**  
Tel: 281-894-5983

**Indianapolis**  
Noblesville, IN  
Tel: 317-773-8323  
Fax: 317-773-5453  
Tel: 317-536-2380

**Los Angeles**  
Mission Viejo, CA  
Tel: 949-462-9523  
Fax: 949-462-9608  
Tel: 951-273-7800

**Raleigh, NC**  
Tel: 919-844-7510

**New York, NY**  
Tel: 631-435-6000

**San Jose, CA**  
Tel: 408-735-9110  
Tel: 408-436-4270

**Canada - Toronto**  
Tel: 905-695-1980  
Fax: 905-695-2078

### ASIA/PACIFIC

**Australia - Sydney**  
Tel: 61-2-9868-6733

**China - Beijing**  
Tel: 86-10-8569-7000

**China - Chengdu**  
Tel: 86-28-8665-5511

**China - Chongqing**  
Tel: 86-23-8980-9588

**China - Dongguan**  
Tel: 86-769-8702-9880

**China - Guangzhou**  
Tel: 86-20-8755-8029

**China - Hangzhou**  
Tel: 86-571-8792-8115

**China - Hong Kong SAR**  
Tel: 852-2943-5100

**China - Nanjing**  
Tel: 86-25-8473-2460

**China - Qingdao**  
Tel: 86-532-8502-7355

**China - Shanghai**  
Tel: 86-21-3326-8000

**China - Shenyang**  
Tel: 86-24-2334-2829

**China - Shenzhen**  
Tel: 86-755-8864-2200

**China - Suzhou**  
Tel: 86-186-6233-1526

**China - Wuhan**  
Tel: 86-27-5980-5300

**China - Xian**  
Tel: 86-29-8833-7252

**China - Xiamen**  
Tel: 86-592-2388138

**China - Zhuhai**  
Tel: 86-756-3210040

### ASIA/PACIFIC

**India - Bangalore**  
Tel: 91-80-3090-4444

**India - New Delhi**  
Tel: 91-11-4160-8631

**India - Pune**  
Tel: 91-20-4121-0141

**Japan - Osaka**  
Tel: 81-6-6152-7160

**Japan - Tokyo**  
Tel: 81-3-6880-3770

**Korea - Daegu**  
Tel: 82-53-744-4301

**Korea - Seoul**  
Tel: 82-2-554-7200

**Malaysia - Kuala Lumpur**  
Tel: 60-3-7651-7906

**Malaysia - Penang**  
Tel: 60-4-227-8870

**Philippines - Manila**  
Tel: 63-2-634-9065

**Singapore**  
Tel: 65-6334-8870

**Taiwan - Hsin Chu**  
Tel: 886-3-577-8366

**Taiwan - Kaohsiung**  
Tel: 886-7-213-7830

**Taiwan - Taipei**  
Tel: 886-2-2508-8600

**Thailand - Bangkok**  
Tel: 66-2-694-1351

**Vietnam - Ho Chi Minh**  
Tel: 84-28-5448-2100

### EUROPE

**Austria - Wels**  
Tel: 43-7242-2244-39  
Fax: 43-7242-2244-393

**Denmark - Copenhagen**  
Tel: 45-4450-2828  
Fax: 45-4485-2829

**Finland - Espoo**  
Tel: 358-9-4520-820

**France - Paris**  
Tel: 33-1-69-53-63-20  
Fax: 33-1-69-30-90-79

**Germany - Garching**  
Tel: 49-8931-9700

**Germany - Haan**  
Tel: 49-2129-3766400

**Germany - Heilbronn**  
Tel: 49-7131-67-3636

**Germany - Karlsruhe**  
Tel: 49-721-625370

**Germany - Munich**  
Tel: 49-89-627-144-0  
Fax: 49-89-627-144-44

**Germany - Rosenheim**  
Tel: 49-8031-354-560

**Israel - Ra'anana**  
Tel: 972-9-744-7705

**Italy - Milan**  
Tel: 39-0331-742611  
Fax: 39-0331-466781

**Italy - Padova**  
Tel: 39-049-7625286

**Netherlands - Drunen**  
Tel: 31-416-690399  
Fax: 31-416-690340

**Norway - Trondheim**  
Tel: 47-7289-7561

**Poland - Warsaw**  
Tel: 48-22-3325737

**Romania - Bucharest**  
Tel: 40-21-407-87-50

**Spain - Madrid**  
Tel: 34-91-708-08-90  
Fax: 34-91-708-08-91



**Sweden - Gothenberg**  
Tel: 46-31-704-60-40

**Sweden - Stockholm**  
Tel: 46-8-5090-4654

**UK - Wokingham**  
Tel: 44-118-921-5800  
Fax: 44-118-921-5820

## Looking for pricing, stock, or lifecycle information?

Click below to explore more details on WIN SOURCE:

-  [View LM4040CYM3-4.1-TR on WIN SOURCE](#)
-  [Microchip Technology](#) Information

## Optimize Your Supply Chain with WIN SOURCE Solutions

-  Global Sourcing Solution
-  Obsolete Management
-  Cost Control Management
-  Shortage Management
-  Alternative Solution
-  Excess Inventory Management