



**THE DATASHEET OF
LTC2054HVIS5#TRMPBF**



FEATURES

- Supply Current 150 μ A (Max per Amplifier) Guaranteed from -40°C to 85°C
- Offset Voltage 3 μ V (Max, -40°C to 85°C)
- Offset Voltage Drift 30nV/ $^{\circ}\text{C}$ (Max, -40°C to 85°C)
- Guaranteed Specifications from -55°C to 150°C (LTC2054MP)
- Common Mode Input Range from V^{-} to $V^{+} - 0.5\text{V}$
- Output Swings Rail-to-Rail
- Voltage Gain: 140dB (Typ)
- PSRR and CMRR: 130dB (Typ)
- Input Bias Current: 1pA (Typ, 25°C)
- Noise: 1.6 μ V_{P-P} (0.01Hz to 10Hz Typ)
- Supply Operation:
 - 2.7V to 6V (LTC2054/LTC2055)
 - 2.7V to $\pm 5.5\text{V}$ (LTC2054HV/LTC2055HV)
- Low Profile (1mm) TSOT-23, MS8 and 3mm \times 3mm \times 0.8mm DFN Packages

APPLICATIONS

- Thermocouple Amplifiers
- Electronic Scales
- Medical Instrumentation
- Strain Gauge Amplifiers
- High Resolution Data Acquisition
- DC Accurate RC Active Filters
- Low Side Current Sense
- Battery-Powered Systems

DESCRIPTION

The LTC[®]2054/LTC2055 are low power, low noise, single/dual, zero-drift operational amplifiers with an extended temperature version (LTC2054MP) that has guaranteed specifications from -55°C to 150°C . They are available in TSOT-23 (ThinSOT[™]) and MS8 packages. For space limited applications, the LTC2055 is also available in a 3mm \times 3mm \times 0.8mm dual fine pitch leadless package (DFN). They operate from a single 2.7V minimum supply and support $\pm 5\text{V}$ applications. The current consumption is typically 150 μ A for the LTC2054 and 130 μ A/amp for the LTC2055.

The LTC2054/LTC2055, despite their miniature size, feature uncompromising DC performance. The maximum input offset voltage and offset drift are 3.0 μ V and 30nV/ $^{\circ}\text{C}$ over the -40°C to 85°C industrial temperature range. The almost zero DC offset and drift are supported with a power supply rejection ratio (PSRR) and common mode rejection ratio (CMRR) of 130dB (typ).

The input common mode voltage ranges from the negative supply up to typically 0.5V below the positive supply. The open-loop gain is typically 140dB. The LTC2054/LTC2055 also feature a 1.6 μ V_{P-P} DC to 10Hz noise and a 500kHz gain-bandwidth product.

LT, LT, LTC, LTM, Linear Technology and the Linear logo are registered trademarks of Linear Technology Corporation. ThinSOT is a trademark of Linear Technology Corporation. All other trademarks are the property of their respective owners.

TYPICAL APPLICATION

-48V Low Side Precision Current Sense



V_{OS} vs Temperature

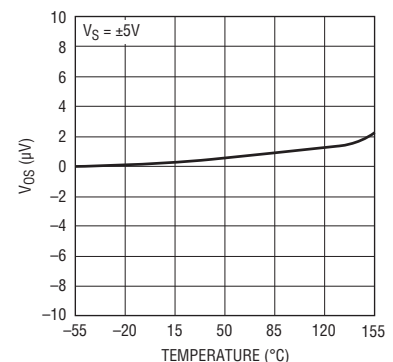

20545 TA01b

20545fc

LTC2054/LTC2055

ABSOLUTE MAXIMUM RATINGS (Note 1)

Total Supply Voltage (V^+ to V^-)	
LTC2054/LTC2055	7V
LTC2054HV/LTC2055HV	12V
Input Voltage	($V^+ + 0.3V$) to ($V_S^- - 0.3V$)
Input Current	$\pm 10mA$
Output Short-Circuit Duration	Indefinite

Specified Temperature Range (Note 2)	
LTC2054C/LTC2055C	0°C to 70°C
LTC2054I/LTC2055I	-40°C to 85°C
LTC2054H/LTC2055H	-40°C to 125°C
LTC2054MP	-55°C to 150°C
Storage Temperature Range	-65°C to 150°C
DD Package	-65°C to 125°C
Lead Temperature (Soldering, 10 sec)	
TSOT23 and MS8 Packages	300°C

PIN CONFIGURATION

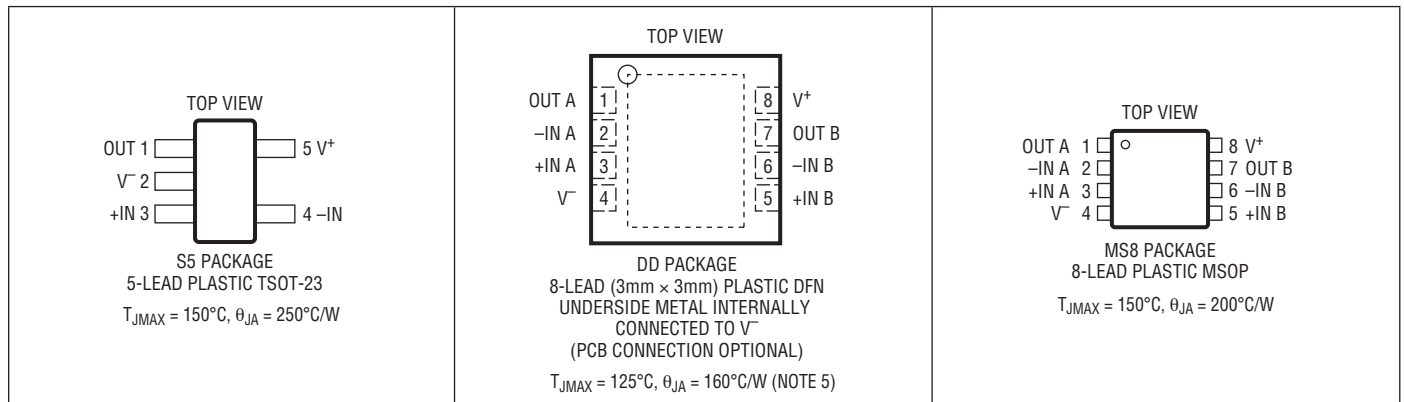

ORDER INFORMATION

LEAD FREE FINISH	TAPE AND REEL	PART MARKING*	PACKAGE DESCRIPTION	SPECIFIED TEMPERATURE RANGE
LTC2054CS5#PBF	LTC2054CS5#TRPBF	LTAGB	5-Lead Plastic TSOT-23	0°C to 70°C
LTC2054HVCSS5#PBF	LTC2054HVCSS5#TRPBF	LTAGD	5-Lead Plastic TSOT-23	0°C to 70°C
LTC2054IS5#PBF	LTC2054IS5#TRPBF	LTAGB	5-Lead Plastic TSOT-23	-40°C to 85°C
LTC2054HVIS5#PBF	LTC2054HVIS5#TRPBF	LTAGD	5-Lead Plastic TSOT-23	-40°C to 85°C
LTC2054HS5#PBF	LTC2054HS5#TRPBF	LTAGB	5-Lead Plastic TSOT-23	-40°C to 125°C
LTC2054HVHS5#PBF	LTC2054HVHS5#TRPBF	LTAGD	5-Lead Plastic TSOT-23	-40°C to 125°C
LTC2055CDD#PBF	LTC2055CDD#TRPBF	LBCW	8-Lead (3mm x 3mm) Plastic DFN	0°C to 70°C
LTC2055HVCDD#PBF	LTC2055HVCDD#TRPBF	LBCX	8-Lead (3mm x 3mm) Plastic DFN	0°C to 70°C
LTC2055IDD#PBF	LTC2055IDD#TRPBF	LBCW	8-Lead (3mm x 3mm) Plastic DFN	-40°C to 85°C
LTC2055HVIDD#PBF	LTC2055HVIDD#TRPBF	LBCX	8-Lead (3mm x 3mm) Plastic DFN	-40°C to 85°C
LTC2055HDD#PBF	LTC2055HDD#TRPBF	LBCW	8-Lead (3mm x 3mm) Plastic DFN	-40°C to 125°C
LTC2055HVHDD#PBF	LTC2055HVHDD#TRPBF	LBCX	8-Lead (3mm x 3mm) Plastic DFN	-40°C to 125°C
LTC2055CMS8#PBF	LTC2054CMS8#TRPBF	LTBCR	8-Lead Plastic MSOP	0°C to 70°C
LTC2055HVCMS8#PBF	LTC2055HVCMS8#TRPBF	LTBCT	8-Lead Plastic MSOP	0°C to 70°C
LTC2055IMS8#PBF	LTC2055IMS8#TRPBF	LTBCR	8-Lead Plastic MSOP	-40°C to 85°C

20545fc

ORDER INFORMATION

LEAD FREE FINISH	TAPE AND REEL	PART MARKING*	PACKAGE DESCRIPTION	SPECIFIED TEMPERATURE RANGE
LTC2055HVIMS8#PBF	LTC2055HVIMS8#TRPBF	LTBCT	8-Lead Plastic MSOP	-40°C to 85°C
LTC2055HMS8#PBF	LTC2055HMS8#TRPBF	LTBCR	8-Lead Plastic MSOP	-40°C to 125°C
LTC2055HVHMS8#PBF	LTC2055HVHMS8#TRPBF	LTBCT	8-Lead Plastic MSOP	-40°C to 125°C
LTC2054MPS5#PBF	LTC2054MPS5#TRPBF	LTFFF	5-Lead Plastic TSOT-23	-55°C to 150°C
LTC2054HVMP5#PBF	LTC2054HVMP5#TRPBF	LTFFG	5-Lead Plastic TSOT-23	-55°C to 150°C

Consult LTC Marketing for parts specified with wider operating temperature ranges. *The temperature grade is identified by a label on the shipping container. Consult LTC Marketing for information on non-standard lead based finish parts.

For more information on lead free part marking, go to: <http://www.linear.com/leadfree/>

For more information on tape and reel specifications, go to: <http://www.linear.com/tapeandreel/>

ELECTRICAL CHARACTERISTICS (LTC2054/LTC2055) The ● denotes the specifications which apply over the full operating temperature range, otherwise specifications are at $T_A = 25^\circ\text{C}$. $V_S = 3\text{V}, 5\text{V}$ unless otherwise noted. (Note 2)

SYMBOL	PARAMETER	CONDITIONS		LTC2054C/LTC2055C LTC2054I/LTC2055I			LTC2054H/LTC2055H			UNITS
				MIN	TYP	MAX	MIN	TYP	MAX	
I_S	Supply Current (LTC2054)	No Load	●		140	175	140	180	μA	
I_S	Supply Current Per Amplifier (LTC2055)	No Load	●		130	150	130	155	μA	
V_{OS}	Input Offset Voltage	(Note 3)			± 0.5	± 3	± 0.5	± 3	μV	
$\Delta V_{OS}/\Delta T$	Average Input Offset Drift	(Note 3)	●		0.02	± 0.03	0.02	± 0.05	$\mu\text{V}/^\circ\text{C}$	
	Long-Term Offset Drift				50		50		$\text{nV}/\sqrt{\text{mo}}$	
I_B	Input Bias Current	(Note 4)	●		± 1	± 150	± 1	± 3000	pA pA	
I_{OS}	Input Offset Current	(Note 4)	●		± 2	± 300	± 2	± 700	pA pA	
e_n	Input Noise Voltage	$R_S = 100\Omega$, DC to 1Hz $R_S = 100\Omega$, DC to 10Hz			0.6 1.6		0.6 1.6		μV_{P-P} μV_{P-P}	
CMRR	Common Mode Rejection Ratio	$V_{CM} = \text{GND to } V^+ - 0.7\text{V}$ $V_S = 3\text{V}$	●		115 110	130	115 110	130	dB dB	
		$V_{CM} = \text{GND to } V^+ - 0.7\text{V}$ $V_S = 5\text{V}$	●		120 115	130	120 115	130	dB dB	
PSRR	Power Supply Rejection Ratio	$V_S = 2.7\text{V to } 6\text{V}$	●		120 115	130	120 115	130	dB dB	
A_{VOL}	Large-Signal Voltage Gain	$R_L = 100\text{k}$, $V_S = 3\text{V}$, $V_{OUT} = V_S/2$	●		120 115	135	120 115	135	dB dB	
		$R_L = 100\text{k}$, $V_S = 5\text{V}$, $V_{OUT} = V_S/2$	●		125 120	140	125 120	140	dB dB	
V_{OUT}	Output Voltage Swing High	$R_L = 5\text{k to GND}$, $V_S = 3\text{V}$ $R_L = 5\text{k to GND}$, $V_S = 3\text{V}$	●		2.87 2.85	2.89	2.87 2.84	2.89	V V	
		$R_L = 5\text{k to GND}$, $V_S = 5\text{V}$ $R_L = 5\text{k to GND}$, $V_S = 5\text{V}$	●		4.80 4.75	4.83	4.80 4.70	4.83	V V	
		$R_L = 100\text{k to GND}$, $V_S = 3\text{V}$ $R_L = 100\text{k to GND}$, $V_S = 3\text{V}$	●		2.98 2.975	2.99	2.98 2.97	2.99	V V	
		$R_L = 100\text{k to GND}$, $V_S = 5\text{V}$ $R_L = 100\text{k to GND}$, $V_S = 5\text{V}$	●		4.985 4.980	4.99	4.985 4.970	4.99	V V	

20545fc

LTC2054/LTC2055

ELECTRICAL CHARACTERISTICS (LTC2054/LTC2055) The ● denotes the specifications which apply over the full operating temperature range, otherwise specifications are at $T_A = 25^\circ\text{C}$. $V_S = 3\text{V}, 5\text{V}$ unless otherwise noted. (Note 2)

SYMBOL	PARAMETER	CONDITIONS		LTC2054C/LTC2055C LTC2054I/LTC2055I			LTC2054H/LTC2055H			UNITS
				MIN	TYP	MAX	MIN	TYP	MAX	
V_{OUT}	Output Voltage Swing Low	$R_L = 5\text{k to GND}, V_S = 3\text{V}$ $R_L = 5\text{k to GND}, V_S = 3\text{V}$	●	2	8	10	3	8	10	mV mV
			●	2	8	10	3	8	10	mV mV
		$R_L = 100\text{k to GND}, V_S = 3\text{V}$ $R_L = 100\text{k to GND}, V_S = 3\text{V}$	●	2	8	10	3	8	10	mV mV
			●	2	8	10	3	8	10	mV mV
SR	Slew Rate			0.5		0.5			V/ μs	
GBW	Gain Bandwidth Product			500		500			kHz	
f_S	Internal Sampling Frequency			1		1			kHz	

(LTC2054HV/LTC2055HV) The ● denotes the specifications which apply over the full operating temperature range, otherwise specifications are at $T_A = 25^\circ\text{C}$. $V_S = \pm 5\text{V}$ unless otherwise noted. (Note 2)

SYMBOL	PARAMETER	CONDITIONS		LTC2054HVC/LTC2055HVC LTC2054HVI/LTC2055HVI			LTC2054HVH/LTC2055HVH			UNITS
				MIN	TYP	MAX	MIN	TYP	MAX	
I_S	Supply Current	No Load (LTC2054)	●	175	210		175	215		μA
I_S	Supply Current (Per Amplifier)	No Load (LTC2055)	●	150	180		150	185		μA
V_{OS}	Input Offset Voltage	(Note 3)		± 0.5	± 5		± 0.5	± 5		μV
$\Delta V_{OS}/\Delta T$	Average Input Offset Drift	(Note 3)	●	0.025	± 0.03		0.025	± 0.05		$\mu\text{V}/^\circ\text{C}$
	Long-Term Offset Drift			50			50			$\text{nV}/\sqrt{\text{mo}}$
I_B	Input Bias Current	(Note 4)	●	± 3		± 150	± 3		± 3000	μA μA
			●	± 6		± 300	± 6		± 700	μA μA
e_n	Input Noise Voltage	$R_S = 100\Omega, \text{DC to } 1\text{Hz}$ $R_S = 100\Omega, \text{DC to } 10\text{Hz}$		0.6	1.6		0.6	1.6		μV_{P-P} μV_{P-P}
CMRR	Common Mode Rejection Ratio	$V_{CM} = \text{GND to } V^+ - 0.9$	●	120	130		120	130		dB dB
			●	115			115			
PSRR	Power Supply Rejection Ratio	$V_S = 2.7\text{V to } 11\text{V}$	●	120	130		120	130		dB dB
			●	115			115			
AVOL	Large-Signal Voltage Gain	$R_L = 100\text{k}, V_{OUT} = \text{GND}$	●	125	140		125	140		dB dB
			●	120			120			
V_{OUT}	Maximum Output Voltage Swing	$R_L = 5\text{k to GND}$ $R_L = 5\text{k to GND}$	●	± 4.78	± 4.82		± 4.78	± 4.82		V V
			●	± 4.75			± 4.70			
V_{OUT}	Maximum Output Voltage Swing	$R_L = 100\text{k to GND}$ $R_L = 100\text{k to GND}$	●	± 4.98	± 4.99		± 4.98	± 4.99		V V
			●	± 4.975			± 4.97			
SR	Slew Rate			0.5		0.5				V/ μs
GBW	Gain Bandwidth Product			500		500				kHz
f_S	Internal Sampling Frequency			1		1				kHz

ELECTRICAL CHARACTERISTICS (LTC2054MP) The ● denotes the specifications which apply over the full operating temperature range, otherwise specifications are at $T_A = 25^\circ\text{C}$. $V_S = 3\text{V}, 5\text{V}$ unless otherwise noted. (Note 2)

SYMBOL	PARAMETER	CONDITIONS		MIN	TYP	MAX	UNITS
I_S	Supply Current	No Load	●		145	190	μA
V_{OS}	Input Offset Voltage	(Note 3) (Note 3) -55°C to 135°C	●			± 10 ± 8	μV μV
$\Delta V_{OS}/\Delta T$	Average Input Offset Drift	(Note 3)	●		0.04	± 0.1	$\mu\text{V}/^\circ\text{C}$
	Long-Term Offset Drift				50		$\text{nV}/\sqrt{\text{mo}}$
I_B	Input Bias Current	(Note 4)	●		± 1	± 12	pA nA
I_{OS}	Input Offset Current	(Note 4)	●		± 2	± 5	pA nA
e_n	Input Noise Voltage	$R_S = 100\Omega$, DC to 1Hz $R_S = 100\Omega$, DC to 10Hz			0.6 1.6		$\mu\text{V}_{\text{P-P}}$ $\mu\text{V}_{\text{P-P}}$
CMRR	Common Mode Rejection Ratio	$V_{\text{CM}} = \text{GND to } V^+ - 0.7\text{V}$ $V_S = 3\text{V}$	●	115 105	130		dB dB
		$V_{\text{CM}} = \text{GND to } V^+ - 0.7\text{V}$ $V_S = 5\text{V}$	●	120 110	130		dB dB
PSRR	Power Supply Rejection Ratio	$V_S = 2.7\text{V to } 6\text{V}$	●	120 110	130		dB dB
A_{VOL}	Large-Signal Voltage Gain	$R_L = 100\text{k}$, $V_S = 3\text{V}$, $V_{\text{OUT}} = V_S/2$	●	120 110	135		dB dB
		$R_L = 100\text{k}$, $V_S = 5\text{V}$, $V_{\text{OUT}} = V_S/2$	●	125 115	140		dB dB
V_{OUT}	Output Voltage Swing High	$R_L = 5\text{k to GND}$, $V_S = 3\text{V}$ $R_L = 5\text{k to GND}$, $V_S = 3\text{V}$	●	2.87 2.84	2.89		V V
		$R_L = 5\text{k to GND}$, $V_S = 5\text{V}$ $R_L = 5\text{k to GND}$, $V_S = 5\text{V}$	●	4.80 4.70	4.83		V V
		$R_L = 100\text{k to GND}$, $V_S = 3\text{V}$ $R_L = 100\text{k to GND}$, $V_S = 3\text{V}$	●	2.98 2.97	2.99		V V
		$R_L = 100\text{k to GND}$, $V_S = 5\text{V}$ $R_L = 100\text{k to GND}$, $V_S = 5\text{V}$	●	4.985 4.970	4.99		V V
V_{OUT}	Output Voltage Swing Low	$R_L = 5\text{k to GND}$, $V_S = 3\text{V}$ $R_L = 5\text{k to GND}$, $V_S = 3\text{V}$	●		3	8 10	mV mV
		$R_L = 5\text{k to GND}$, $V_S = 5\text{V}$ $R_L = 5\text{k to GND}$, $V_S = 5\text{V}$	●		3	8 10	mV mV
		$R_L = 100\text{k to GND}$, $V_S = 3\text{V}$ $R_L = 100\text{k to GND}$, $V_S = 3\text{V}$	●		3	8 10	mV mV
		$R_L = 100\text{k to GND}$, $V_S = 5\text{V}$ $R_L = 100\text{k to GND}$, $V_S = 5\text{V}$	●		3	8 10	mV mV
SR	Slew Rate			0.5		$\text{V}/\mu\text{s}$	
GBW	Gain Bandwidth Product			500		kHz	
f_S	Internal Sampling Frequency			1		kHz	

ELECTRICAL CHARACTERISTICS

(LTC2054HVMP) The ● denotes the specifications which apply over the full operating temperature range, otherwise specifications are at $T_A = 25^\circ\text{C}$. $V_S = \pm 5\text{V}$ unless otherwise noted. (Note 2)

SYMBOL	PARAMETER	CONDITIONS		MIN	TYP	MAX	UNITS
I_S	Supply Current	No Load	●		175	220	μA
V_{OS}	Input Offset Voltage	(Note 3)	●			± 10	μV
$\Delta V_{OS}/\Delta T$	Average Input Offset Drift	(Note 3)	●		0.05	± 0.1	$\mu\text{V}/^\circ\text{C}$
	Long-Term Offset Drift				50		$\text{nV}/\sqrt{\text{mo}}$
I_B	Input Bias Current	(Note 4)	●		± 3	± 12	μA nA
I_{OS}	Input Offset Current	(Note 4)	●		± 6	± 5	μA nA
e_n	Input Noise Voltage	$R_S = 100\Omega$, DC to 1Hz $R_S = 100\Omega$, DC to 10Hz			0.6 1.6		μV_{P-P} μV_{P-P}
CMRR	Common Mode Rejection Ratio	$V_{CM} = \text{GND to } V^+ - 0.9$	●	120 110	130		dB dB
PSRR	Power Supply Rejection Ratio	$V_S = 2.7\text{V to } 11\text{V}$	●	120 110	130		dB dB
AVOL	Large-Signal Voltage Gain	$R_L = 100\text{k}$, $V_{OUT} = \text{GND}$	●	125 115	140		dB dB
V_{OUT}	Maximum Output Voltage Swing	$R_L = 5\text{k to GND}$ $R_L = 5\text{k to GND}$	●	± 4.78 ± 4.675	± 4.82		V V
		$R_L = 100\text{k to GND}$ $R_L = 100\text{k to GND}$	●	± 4.98 ± 4.965	± 4.99		V V
SR	Slew Rate			0.5		$\text{V}/\mu\text{s}$	
GBW	Gain Bandwidth Product			500		kHz	
f_S	Internal Sampling Frequency			1		kHz	

Note 1: Stresses beyond those listed under Absolute Maximum Ratings may cause permanent damage to the device. Exposure to any Absolute Maximum Rating condition for extended periods may affect device reliability and lifetime.

Note 2: The LTC2054/LTC2055 are designed, characterized and expected to meet the extended temperature limits of -40°C and 125°C . The LTC2054C/LTC2055C/LTC2054HVC/LTC2055HVC are guaranteed to meet the temperature limits of 0°C and 70°C . The LTC2054I/LTC2055I/LTC2054HVI/LTC2055HVI are guaranteed to meet temperature limits of -40°C and 85°C . The LTC2054H/LTC2055H and LTC2054HVH/LTC2055HVH are guaranteed to meet the temperature limits of -40°C and 125°C . The LTC2054MP/LTC2054HVMP are guaranteed to meet the temperature limits of -55°C and 150°C .

Note 3: These parameters are guaranteed by design. Thermocouple effects preclude measurements of these voltage levels during automated testing.

Note 4: Limit is determined by high speed automated test capability. See Typical Characteristic curves for actual typical performance. For tighter specifications, please consult Linear Technology Marketing.

Note 5: The θ_{JA} specified for the DD package is with minimal PCB heat spreading metal. Using expanded metal area on all layers of a board reduces this value.

TYPICAL PERFORMANCE CHARACTERISTICS

Common Mode Rejection Ratio vs Frequency



20545 G01

DC CMRR vs Common Mode Input Range



20545 G02

PSRR vs Frequency



20545 G03

Output Voltage Swing vs Load Resistance

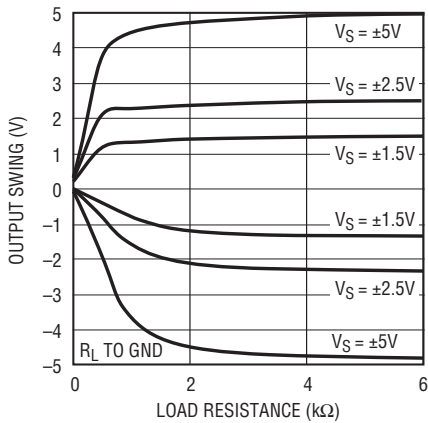

20545 G04

Output Swing vs Load Current

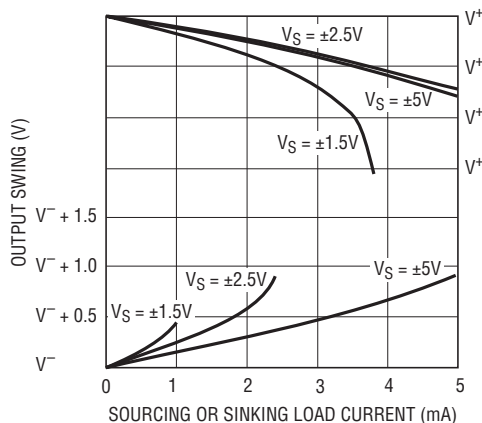

20545 G05

Short-Circuit Output Current vs Supply Voltage

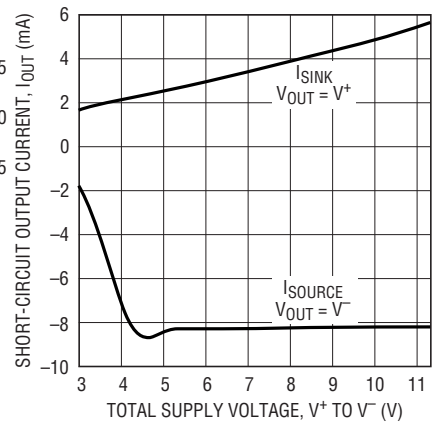

20545 G06

Gain/Phase vs Frequency

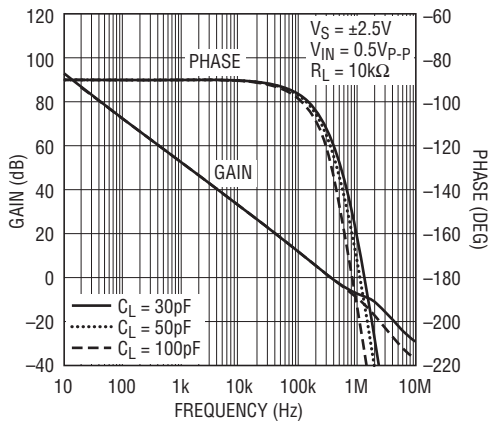

20545 G07

Input Bias Current vs Temperature

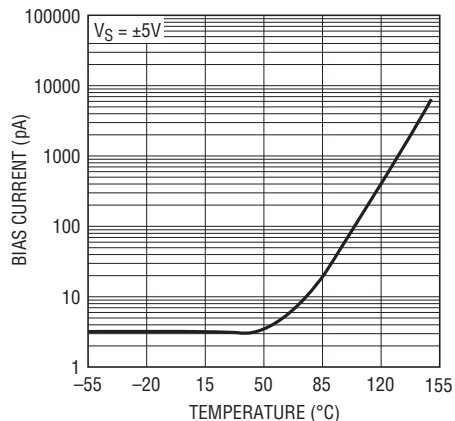

20545 G08

TYPICAL PERFORMANCE CHARACTERISTICS

V_{OS} vs Temperature



20545 G09

Input Bias Current vs Input Common Mode Voltage

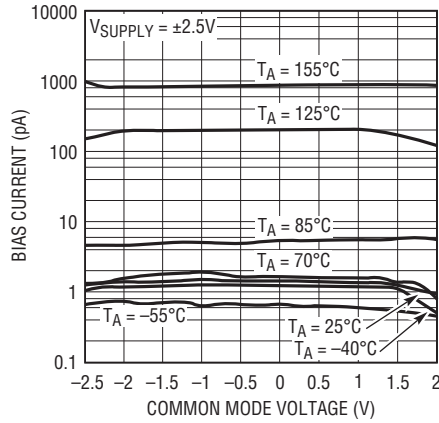

20545 G10

Transient Response



$A_V = 1$
 $R_L = 100k$
 $C_L = 50pF$
 $V_S = \pm 2.5V$
 $V_{IN} = 10kHz\ 2V_{p-p}$

20545 G11

Output Overload Recovery



$A_V = -100$
 $R_L = 100k$
 $V_S = \pm 2.5V$

20545 G12

Output Overload Recovery

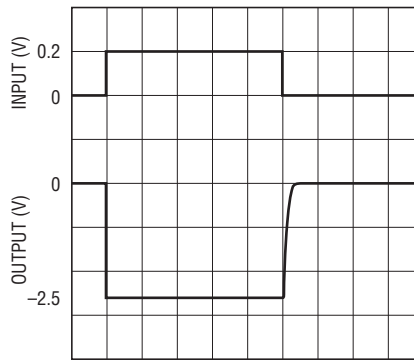

$A_V = -100$
 $R_L = 100k$
 $V_S = \pm 2.5V$

20545 G13

Common Mode Input Range

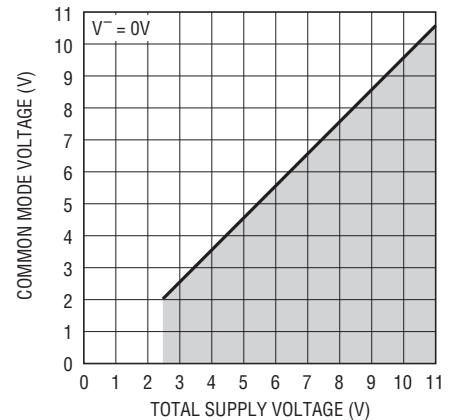

20545 G14

Supply Current vs Supply Voltage



20545 G15

Supply Current vs Temperature

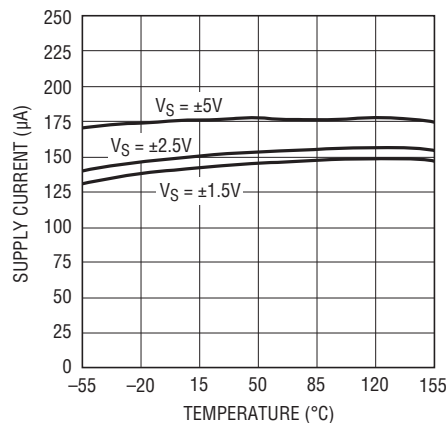

20545 G16

Noise Spectrum



20545 G17

TEST CIRCUITS

Electrical Characteristics Test Circuit



DC-10Hz Noise Test Circuit



FOR 1Hz NOISE BW INCREASE ALL THE CAPACITORS BY A FACTOR OF 10.

20545 TC02

APPLICATIONS INFORMATION

Clock Feedthrough, Input Bias Current

The LTC2054 and LTC2055 use auto-zeroing circuitry to achieve an almost zero DC offset over temperature, common mode voltage, and power supply voltage. The frequency of the clock used for auto-zeroing is typically 1.0kHz. The term “clock feedthrough” is broadly used to indicate visibility of this clock frequency in the op amp output spectrum. There are typically two types of clock feedthrough in auto-zeroed op amps like the LTC2054/LTC2055.

The first form of clock feedthrough is caused by the settling of the internal sampling capacitor and is input referred; that is, it is multiplied by the closed loop gain of the op amp. This form of clock feedthrough is independent of the magnitude of the input source resistance or the magnitude of the gain setting resistors. The LTC2054/LTC2055 have an input referred residue clock feedthrough of less than $0.2\mu\text{V}_{\text{RMS}}$ at 1.0kHz.

The second form of clock feedthrough is caused by the small amount of charge injection occurring during the sampling and holding of the op amp’s input offset voltage. The current spikes are multiplied by the impedance seen at the input terminals of the op amp, and the resulting voltage spikes appear at the output multiplied by the closed loop gain of the op amp. To reduce this form of clock feedthrough, use smaller valued gain setting resistors and minimize the source resistance at the input. If the resistance seen at the inputs is less than $10\text{k}\Omega$, this form of clock feedthrough is less than the amount of residue clock feedthrough from the first form described above.

Placing a capacitor across the feedback resistor reduces either form of clock feedthrough by limiting the bandwidth of the closed loop gain.

Input bias current is defined as the DC current into the input pins of the op amp. The same current spikes that

DC to 1Hz Noise

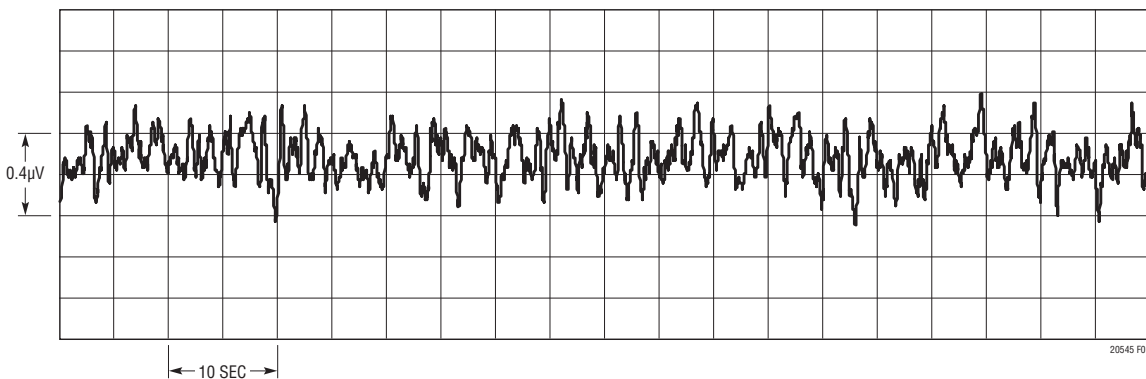

DC to 10Hz Noise



APPLICATIONS INFORMATION

cause the second form of clock feedthrough described above, when averaged, dominate the DC input bias current of the op amp below 70°C.

At temperatures above 70°C, the leakage of the ESD protection diodes on the inputs increases the input bias currents of both inputs in the positive direction, while the current caused by the charge injection stays relatively constant. At elevated temperatures (above 70°C) the leakage current begins to dominate and both the negative and positive pins' input bias currents are in the positive direction (into the pins).

Extended Common Mode Range

The LTC2054/LTC2055 input stage is designed to allow nearly rail-to-rail input common mode signals. In addition, signals that extend beyond the allowed input common mode range do not cause output phase inversion.

Voltage Follower with Input Exceeding the Common Mode Range

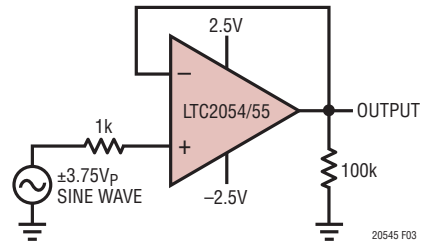

Extended Common Mode Range

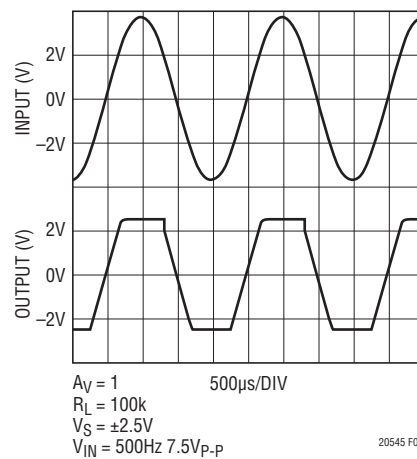

TYPICAL APPLICATIONS

Simple Differential Bridge Amplifier

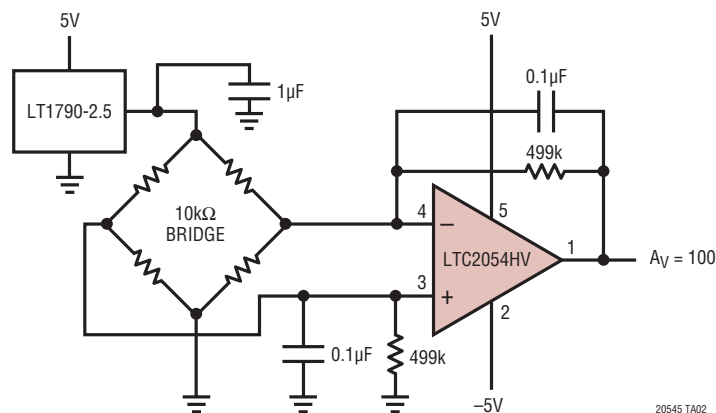

TYPICAL APPLICATIONS

Ground Referred Precision Current Sources



Instrumentation Amplifier with 100V Common Mode Input Voltage



Gain of 1001 Single Supply Instrumentation Amplifier

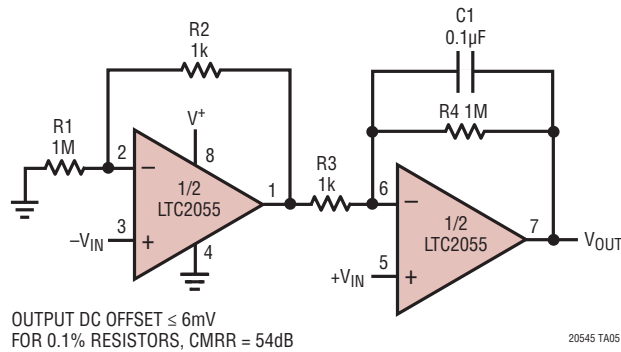

PACKAGE DESCRIPTION

DD Package
8-Lead Plastic DFN (3mm × 3mm)
 (Reference LTC DWG # 05-08-1698 Rev C)

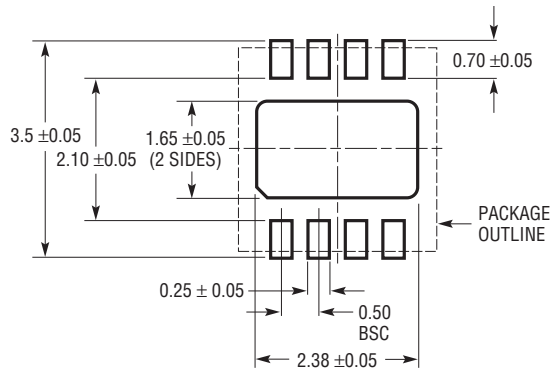

RECOMMENDED SOLDER PAD PITCH AND DIMENSIONS
 APPLY SOLDER MASK TO AREAS THAT ARE NOT SOLDERED

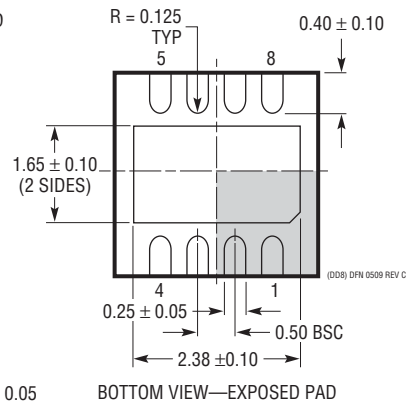
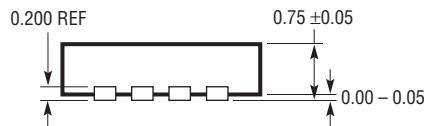
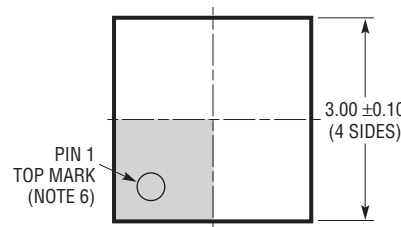

NOTE:

1. DRAWING TO BE MADE A JEDEC PACKAGE OUTLINE M0-229 VARIATION OF (WEED-1)
2. DRAWING NOT TO SCALE
3. ALL DIMENSIONS ARE IN MILLIMETERS
4. DIMENSIONS OF EXPOSED PAD ON BOTTOM OF PACKAGE DO NOT INCLUDE MOLD FLASH. MOLD FLASH, IF PRESENT, SHALL NOT EXCEED 0.15mm ON ANY SIDE
5. EXPOSED PAD SHALL BE SOLDER PLATED
6. SHADED AREA IS ONLY A REFERENCE FOR PIN 1 LOCATION ON TOP AND BOTTOM OF PACKAGE

PACKAGE DESCRIPTION

MS8 Package 8-Lead Plastic MSOP

(Reference LTC DWG # 05-08-1660 Rev F)

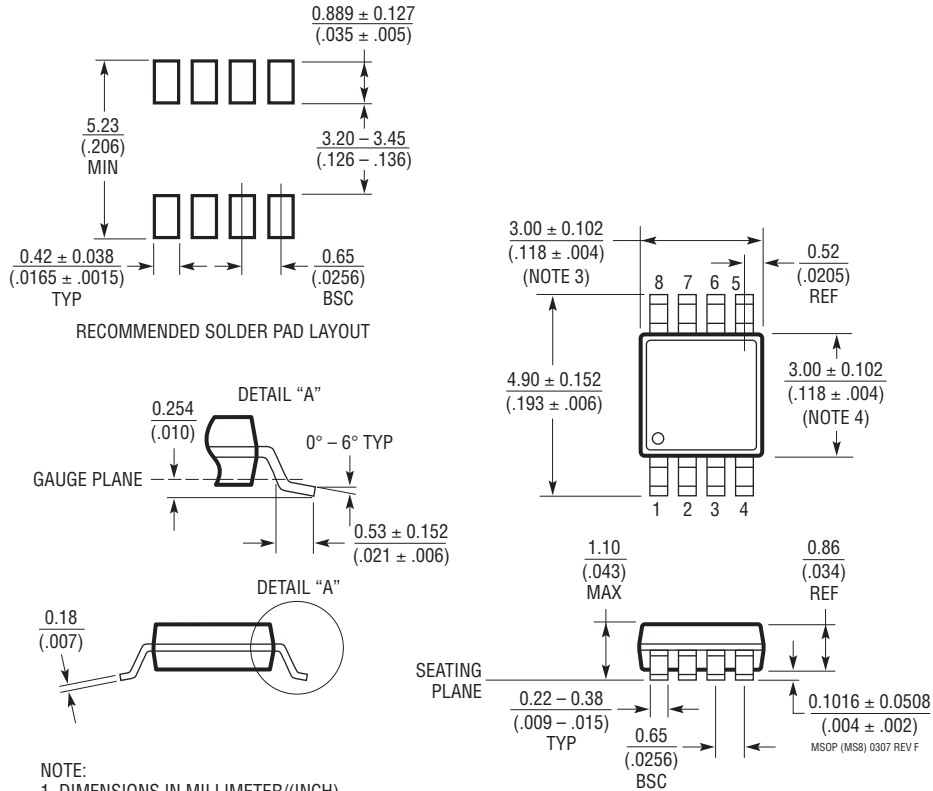

NOTE:

1. DIMENSIONS IN MILLIMETER/(INCH)
2. DRAWING NOT TO SCALE
3. DIMENSION DOES NOT INCLUDE MOLD FLASH, PROTRUSIONS OR GATE BURRS.
MOLD FLASH, PROTRUSIONS OR GATE BURRS SHALL NOT EXCEED 0.152mm (.006") PER SIDE
4. DIMENSION DOES NOT INCLUDE INTERLEAD FLASH OR PROTRUSIONS.
INTERLEAD FLASH OR PROTRUSIONS SHALL NOT EXCEED 0.152mm (.006") PER SIDE
5. LEAD COPLANARITY (BOTTOM OF LEADS AFTER FORMING) SHALL BE 0.102mm (.004") MAX

PACKAGE DESCRIPTION

S5 Package 5-Lead Plastic TSOT-23 (Reference LTC DWG # 05-08-1635)

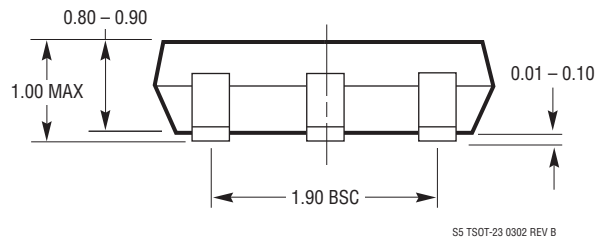

- NOTE:
1. DIMENSIONS ARE IN MILLIMETERS
 2. DRAWING NOT TO SCALE
 3. DIMENSIONS ARE INCLUSIVE OF PLATING
 4. DIMENSIONS ARE EXCLUSIVE OF MOLD FLASH AND METAL BURR
 5. MOLD FLASH SHALL NOT EXCEED 0.254mm
 6. JEDEC PACKAGE REFERENCE IS MO-193

S5 TSOT-23 0302 REV B

TYPICAL APPLICATIONS

Low Power, Bidirectional 60V Precision Hi Side Current Sense



Precision Low Drift Integrator

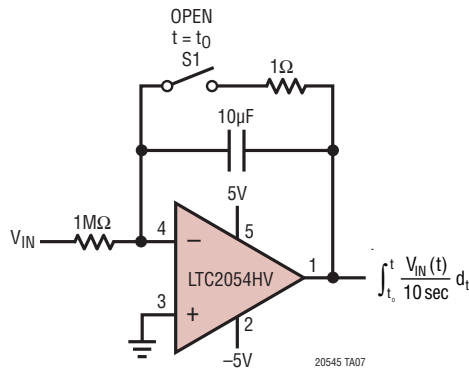

Ultra-Precision, Wide Dynamic Range 10Hz Bandwidth Photodiode Amplifier

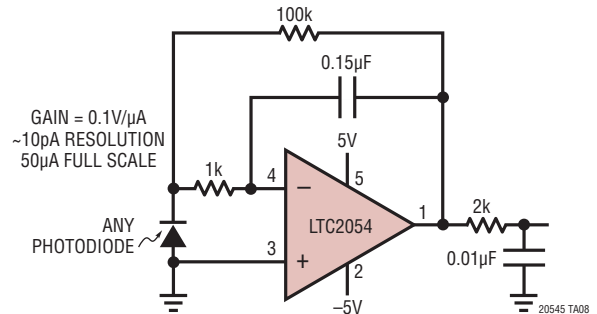



RELATED PARTS

PART NUMBER	DESCRIPTION	COMMENTS
LTC1049	Low Power Zero-Drift Op Amp	Low Supply Current 200μA
LTC1050	Precision Zero-Drift Op Amp	Single Supply Operation 4.75V to 16V, Noise Tested and Guaranteed
LTC1051/LTC1053	Precision Zero-Drift Op Amp	Dual/Quad Version of the LTC1050
LTC1150	±15V Zero-Drift Op Amp	High Voltage Operation ±18V
LTC1152	Rail-to-Rail Input and Output Zero-Drift Op Amp	Single Zero-Drift Op Amp with Rail-to-Rail Input and Output and Shutdown
LT1677	Low Noise Rail-to-Rail Input and Output Precision Op Amp	$V_{OS} = 90\mu V$, $V_S = 2.7V$ to 44V
LT1884/LT1885	Rail-to-Rail Output Precision Op Amp	$V_{OS} = 50\mu V$, $I_B = 400pA$, $V_S = 2.7V$ to 40V
LTC2050	Zero-Drift Op Amp	Enhanced Output Drive Capability
LTC2051/LTC2052	Dual/Quad Zero-Drift Op Amp	Dual/Quad Version of the LTC2050 in MS8/GN16 Package
LTC2053	Zero-Drift Instrumentation Amp	Rail-to-Rail Input

Looking for pricing, stock, or lifecycle information?

Click below to explore more details on WIN SOURCE:

-  [View LTC2054HVIS5#TRMPBF](#) on WIN SOURCE
-  [Linear Technology](#) Information

Optimize Your Supply Chain with WIN SOURCE Solutions

-  Global Sourcing Solution
-  Obsolete Management
-  Cost Control Management
-  Shortage Management
-  Alternative Solution
-  Excess Inventory Management