



**THE DATASHEET OF
ADS1602IPFBT**



16-Bit, 2.5MSPS Analog-to-Digital Converter

Check for Samples: [ADS1602](#)

FEATURES

- **High Speed:**
 - Data Rate: 2.5MSPS
 - Bandwidth: 1.23MHz
- **Outstanding Performance:**
 - SNR: 91dB at $f_{IN} = 100\text{kHz}$, -1dBFS
 - THD: -101dB at $f_{IN} = 100\text{kHz}$, -6dBFS
 - SFDR: 103dB at $f_{IN} = 100\text{kHz}$, -6dBFS
- **Ease-of-Use:**
 - High-Speed 3-Wire Serial Interface
 - Directly Connects to TMS320 DSPs
 - On-Chip Digital Filter Simplifies Antialias Requirements
 - Simple Pin-Driven Control—No On-Chip Registers to Program
 - Selectable On-Chip Voltage Reference
 - Simultaneous Sampling with Multiple ADS1602s
- **Low Power:**
 - 530mW at 2.5MSPS
 - Power-Down Mode

APPLICATIONS

- Sonar
- Vibration Analysis
- Data Acquisition

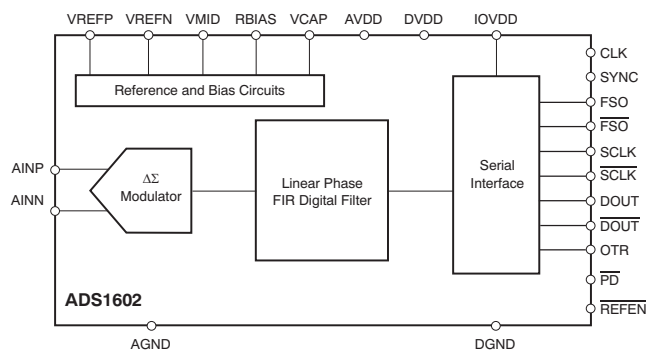

DESCRIPTION

The ADS1602 is a high-speed, high-precision, delta-sigma ($\Delta\Sigma$) analog-to-digital converter (ADC) manufactured on an advanced CMOS process. The ADS1602 oversampling topology reduces clock jitter sensitivity during the sampling of high-frequency, large amplitude signals by a factor of four over that achieved by Nyquist-rate ADCs. Consequently, signal-to-noise ratio (SNR) is particularly improved. Total harmonic distortion (THD) is -101dB , and the spurious-free dynamic range (SFDR) is 103dB.

Optimized for power and performance, the ADS1602 dissipates only 530mW while providing a full-scale differential input range of $\pm 3\text{V}$. Having such a wide input range makes out-of-range signals unlikely. The OTR pin indicates if an analog input out-of-range condition does occur. The differential input signal is measured against the differential reference, which can be generated internally or supplied externally on the ADS1602.

The ADS1602 uses an inherently stable advanced modulator with an on-chip decimation filter. The filter stop band extends to 38.6MHz, which greatly simplifies the antialiasing circuitry. The modulator samples the input signal up to 40MSPS, depending on f_{CLK} , while the 16x decimation filter uses a series of four half-band FIR filter stages to provide 75dB of stop band attenuation and 0.001dB of passband ripple.

Output data is provided over a simple 3-wire serial interface at rates up to 2.5MSPS, with a -3dB bandwidth of 1.23MHz. The output data or its complementary format directly connects to DSPs such as TI's [TMS320 family](#), FPGAs, or ASICs. A dedicated synchronization pin enables simultaneous sampling with multiple ADS1602s in multi-channel systems. Power dissipation is set by an external resistor that allows a reduction in dissipation when operating at slower speeds. All of the ADS1602 features are controlled by dedicated I/O pins, which simplify operation by eliminating the need for on-chip registers.

The high performing, easy-to-use ADS1602 is especially suitable for demanding measurement applications in sonar, vibration analysis, and data acquisition. The ADS1602 is offered in a small, 7mm \times 7mm TQFP-48 package and is specified from -40°C to $+85^\circ\text{C}$.



Please be aware that an important notice concerning availability, standard warranty, and use in critical applications of Texas Instruments semiconductor products and disclaimers thereto appears at the end of this data sheet.

All trademarks are the property of their respective owners.



This integrated circuit can be damaged by ESD. Texas Instruments recommends that all integrated circuits be handled with appropriate precautions. Failure to observe proper handling and installation procedures can cause damage.

ESD damage can range from subtle performance degradation to complete device failure. Precision integrated circuits may be more susceptible to damage because very small parametric changes could cause the device not to meet its published specifications.

PACKAGE/ORDERING INFORMATION

For the most current package and ordering information, see the Package Option Addendum at the end of this document, or visit the device product folder at www.ti.com.

ABSOLUTE MAXIMUM RATINGS⁽¹⁾

Over operating free-air temperature range, unless otherwise noted.

	ADS1602	UNIT
AVDD to AGND	–0.3 to +6	V
DVDD to DGND	–0.3 to +3.6	V
IOVDD to DGND	–0.3 to +6	V
AGND to DGND	–0.3 to +0.3	V
Input current	100, momentary	mA
Input current	10, continuous	mA
Analog I/O to AGND	–0.3 to AVDD + 0.3	V
Digital I/O to DGND	–0.3 to IOVDD + 0.3	V
Maximum junction temperature	+150	°C
Operating temperature range	–40 to +105	°C
Storage temperature range	–60 to +150	°C

- (1) Stresses above these ratings may cause permanent damage. Exposure to absolute maximum conditions for extended periods may degrade device reliability. These are stress ratings only, and functional operation of the device at these or any other conditions beyond those specified is not implied.

ELECTRICAL CHARACTERISTICS

All specifications at $T_A = -40^\circ\text{C}$ to $+85^\circ\text{C}$, $AVDD = 5\text{V}$, $DVDD = IOVDD = 3\text{V}$, $f_{\text{CLK}} = 40\text{MHz}$, external $V_{\text{REF}} = +3\text{V}$, $V_{\text{CM}} = +1.45\text{V}$, and $R_{\text{BIAS}} = 37\text{k}\Omega$, unless otherwise noted.

PARAMETER	TEST CONDITIONS	ADS1602			UNIT
		MIN	TYP	MAX	
Analog Input					
Differential input voltage (V_{IN}) ($A_{\text{INP}} - A_{\text{INN}}$)	0dBFS		$\pm V_{\text{REF}}$		V
Common-mode input voltage (V_{CM}) ($A_{\text{INP}} + A_{\text{INN}} / 2$)			1.45		V
Absolute input voltage (A_{INP} or A_{INN} with respect to AGND)		-0.1		4.6	V
Dynamic Specifications					
Data rate			$2.5 \left(\frac{f_{\text{CLK}}}{40\text{MHz}} \right)$		MSPS
Signal-to-noise ratio (SNR)	$f_{\text{IN}} = 10\text{kHz}, -1\text{dBFS}$		92		dB
	$f_{\text{IN}} = 10\text{kHz}, -3\text{dBFS}$	87	90		dB
	$f_{\text{IN}} = 10\text{kHz}, -6\text{dBFS}$	84	87		dB
	$f_{\text{IN}} = 100\text{kHz}, -1\text{dBFS}$		91		dB
	$f_{\text{IN}} = 100\text{kHz}, -3\text{dBFS}$	87	89		dB
	$f_{\text{IN}} = 100\text{kHz}, -6\text{dBFS}$	84	86		dB
	$f_{\text{IN}} = 800\text{kHz}, -1\text{dBFS}$		91		dB
	$f_{\text{IN}} = 800\text{kHz}, -3\text{dBFS}$		89		dB
Total harmonic distortion (THD)	$f_{\text{IN}} = 10\text{kHz}, -1\text{dBFS}$		-94		dB
	$f_{\text{IN}} = 10\text{kHz}, -3\text{dBFS}$		-106	-92	dB
	$f_{\text{IN}} = 10\text{kHz}, -6\text{dBFS}$		-108	-93	dB
	$f_{\text{IN}} = 100\text{kHz}, -1\text{dBFS}$		-90		dB
	$f_{\text{IN}} = 100\text{kHz}, -3\text{dBFS}$		-96	-90	dB
	$f_{\text{IN}} = 100\text{kHz}, -6\text{dBFS}$		-101	-92	dB
	$f_{\text{IN}} = 800\text{kHz}, -1\text{dBFS}$		-116		dB
	$f_{\text{IN}} = 800\text{kHz}, -3\text{dBFS}$		-114		dB
Signal-to-noise + distortion (SINAD)	$f_{\text{IN}} = 10\text{kHz}, -1\text{dBFS}$		89		dB
	$f_{\text{IN}} = 10\text{kHz}, -3\text{dBFS}$	85	90		dB
	$f_{\text{IN}} = 10\text{kHz}, -6\text{dBFS}$	82	87		dB
	$f_{\text{IN}} = 100\text{kHz}, -1\text{dBFS}$		87		dB
	$f_{\text{IN}} = 100\text{kHz}, -3\text{dBFS}$	85	88		dB
	$f_{\text{IN}} = 100\text{kHz}, -6\text{dBFS}$	82	86		dB
	$f_{\text{IN}} = 800\text{kHz}, -1\text{dBFS}$		91		dB
	$f_{\text{IN}} = 800\text{kHz}, -3\text{dBFS}$		89		dB
Spurious-free dynamic range (SFDR)	$f_{\text{IN}} = 10\text{kHz}, -1\text{dBFS}$		95		dB
	$f_{\text{IN}} = 10\text{kHz}, -3\text{dBFS}$	90	107		dB
	$f_{\text{IN}} = 10\text{kHz}, -6\text{dBFS}$	93	112		dB
	$f_{\text{IN}} = 100\text{kHz}, -1\text{dBFS}$		91		dB
	$f_{\text{IN}} = 100\text{kHz}, -3\text{dBFS}$	90	96		dB
	$f_{\text{IN}} = 100\text{kHz}, -6\text{dBFS}$	93	103		dB
	$f_{\text{IN}} = 800\text{kHz}, -1\text{dBFS}$		120		dB
	$f_{\text{IN}} = 800\text{kHz}, -3\text{dBFS}$		119		dB
Intermodulation distortion (IMD)	$f_1 = 995\text{kHz}, -6\text{dBFS}$ $f_2 = 1005\text{kHz}, -6\text{dBFS}$		94		dB
			114		dB
Aperture delay			4		ns

ELECTRICAL CHARACTERISTICS (continued)

All specifications at $T_A = -40^{\circ}\text{C}$ to $+85^{\circ}\text{C}$, $AVDD = 5\text{V}$, $DVDD = IOVDD = 3\text{V}$, $f_{\text{CLK}} = 40\text{MHz}$, external $V_{\text{REF}} = +3\text{V}$, $V_{\text{CM}} = +1.45\text{V}$, and $R_{\text{BIAS}} = 37\text{k}\Omega$, unless otherwise noted.

PARAMETER	TEST CONDITIONS	ADS1602			UNIT
		MIN	TYP	MAX	
Digital Filter Characteristics					
Passband		0	$1.1 \left(\frac{f_{\text{CLK}}}{40\text{MHz}} \right)$		MHz
Passband ripple				± 0.001	dB
Passband transition	-0.1dB attenuation		$1.15 \left(\frac{f_{\text{CLK}}}{40\text{MHz}} \right)$		MHz
	-3dB attenuation		$1.23 \left(\frac{f_{\text{CLK}}}{40\text{MHz}} \right)$		MHz
Stop band		$1.4 \left(\frac{f_{\text{CLK}}}{40\text{MHz}} \right)$		$38.6 \left(\frac{f_{\text{CLK}}}{40\text{MHz}} \right)$	MHz
Stop band attenuation		75			dB
Group delay			$10.4 \left(\frac{40\text{MHz}}{f_{\text{CLK}}} \right)$		μs
Settling time	Complete settling		$20.4 \left(\frac{40\text{MHz}}{f_{\text{CLK}}} \right)$		μs
Static Specifications					
Resolution		16			Bits
No missing codes			16		Bits
Input-referred noise			0.5	0.85	LSB, rms
Integral nonlinearity	-1dBFS signal		0.75		LSB
Differential nonlinearity			0.25		LSB
Offset error			-0.1		%FSR
Offset error drift			-0.1		ppmFSR/ $^{\circ}\text{C}$
Gain error			$0.25^{(1)}$		%
Gain error drift	Excluding reference drift		10		ppm/ $^{\circ}\text{C}$
Common-mode rejection	At dc		75		dB
Power-supply rejection	At dc		65		dB
Internal Voltage Reference					
	$\overline{\text{REFEN}} = \text{low}$				
$V_{\text{REF}} = (V_{\text{REFP}} - V_{\text{REFN}})$		2.75	3	3.25	V
V_{REFP}		3.5	4	4.3	V
V_{REFN}		0.5	1	1.3	V
VMID		2.3	2.5	2.7	V
V_{REF} drift			50		ppm/ $^{\circ}\text{C}$
Startup time			15		ms
External Voltage Reference					
	$\overline{\text{REFEN}} = \text{high}$				
$V_{\text{REF}} = (V_{\text{REFP}} - V_{\text{REFN}})$		2	3	3.25	V
V_{REFP}		3.5	4	4.25	V
V_{REFN}		0.5	1	1.5	V
VMID		2.3	2.5	2.6	V

(1) There is a constant gain error of 2.5% in addition to the variable gain error of $\pm 0.25\%$. Therefore, the gain error is $2.5 \pm 0.25\%$.

ELECTRICAL CHARACTERISTICS (continued)

All specifications at $T_A = -40^\circ\text{C}$ to $+85^\circ\text{C}$, $AVDD = 5\text{V}$, $DVDD = IOVDD = 3\text{V}$, $f_{\text{CLK}} = 40\text{MHz}$, external $V_{\text{REF}} = +3\text{V}$, $V_{\text{CM}} = +1.45\text{V}$, and $R_{\text{BIAS}} = 37\text{k}\Omega$, unless otherwise noted.

PARAMETER	TEST CONDITIONS	ADS1602			UNIT
		MIN	TYP	MAX	
Clock Input					
Frequency (f_{CLK})				40	MHz
Duty cycle	$f_{\text{CLK}} = 40\text{MHz}$	45		55	%
Digital Input/Output					
V_{IH}		$0.7 \times IOVDD$		$IOVDD$	V
V_{IL}		DGND		$0.3 \times IOVDD$	V
V_{OH}	$I_{\text{OH}} = 50\mu\text{A}$	$IOVDD - 0.5$			V
V_{OL}	$I_{\text{OL}} = 50\mu\text{A}$			DGND + 0.5	V
Input leakage	$DGND < V_{\text{DIGIN}} < IOVDD$			± 10	μA
Power-Supply Requirements					
AVDD		4.75		5.25	V
DVDD		2.7		3.3	V
IOVDD	$I_{\text{OH}} = 50\mu\text{A}$	2.7		5.25	V
AVDD current (I_{AVDD})	$\overline{\text{REFEN}} = \text{low}$		110	125	mA
	$\overline{\text{REFEN}} = \text{high}$		88	98	mA
DVDD current (I_{DVDD})	$IOVDD = 3\text{V}$		25	30	mA
IOVDD current (I_{IOVDD})	$IOVDD = 3\text{V}$		8	10	mA
Power dissipation	$AVDD = 5\text{V}$, $DVDD = 3\text{V}$, $IOVDD = 3\text{V}$, $\overline{\text{REFEN}} = \text{high}$		530	610	mW
	$\overline{\text{PD}} = \text{low}$, CLK disabled		10		mW
Temperature Range					
Specified		-40		+85	$^\circ\text{C}$
Operating		-40		+105	$^\circ\text{C}$
Storage		-60		+150	$^\circ\text{C}$

DEFINITIONS

Absolute Input Voltage

Absolute input voltage, given in volts, is the voltage of each analog input (AINN or AINP) with respect to AGND.

Aperture Delay

Aperture delay is the delay between the rising edge of CLK and the sampling of the input signal.

Common-Mode Input Voltage

Common-mode input voltage (V_{CM}) is the average voltage of the analog inputs:

$$\frac{(AINP + AINN)}{2}$$

Differential Input Voltage

Differential input voltage (V_{IN}) is the voltage difference between the analog inputs (AINP – AINN).

Differential Nonlinearity (DNL)

DNL, given in least-significant bits of the output code (LSB), is the maximum deviation of the output code step sizes from the ideal value of 1LSB.

Full-Scale Range (FSR)

FSR is the difference between the maximum and minimum measurable input signals ($FSR = 2V_{REF}$).

Gain Error

Gain error, given in %, is the error of the full-scale input signal with respect to the ideal value.

Gain Error Drift

Gain error drift, given in ppm/°C, is the drift over temperature of the gain error. The gain error is specified as the larger of the drift from ambient ($T = +25^{\circ}\text{C}$) to the minimum or maximum operating temperatures.

Integral Nonlinearity (INL)

INL, given in least-significant bits of the output code (LSB), is the maximum deviation of the output codes from a best fit line.

Intermodulation Distortion (IMD)

IMD, given in dB, is measured while applying two input signals of the same magnitude, but with slightly different frequencies. It is calculated as the difference between the rms amplitude of the input signal to the rms amplitude of the peak spurious signal.

Offset Error

Offset Error, given in % of FSR, is the output reading when the differential input is zero.

Offset Error Drift

Offset error drift, given in ppm of FSR/°C, is the drift over temperature of the offset error. The offset error is specified as the larger of the drift from ambient ($T = +25^{\circ}\text{C}$) to the minimum or maximum operating temperatures.

Signal-to-Noise Ratio (SNR)

SNR, given in dB, is the ratio of the rms value of the input signal to the sum of all the frequency components below $f_{CLK}/2$ (the Nyquist frequency) excluding the first six harmonics of the input signal and the dc component.

Signal-to-Noise and Distortion (SINAD)

SINAD, given in dB, is the ratio of the rms value of the input signal to the sum of all the frequency components below $f_{CLK}/2$ (the Nyquist frequency) including the harmonics of the input signal but excluding the dc component.

Spurious-Free Dynamic Range (SFDR)

SFDR, given in dB, is the difference between the rms amplitude of the input signal to the rms amplitude of the peak spurious signal.

Total Harmonic Distortion (THD)

THD, given in dB, is the ratio of the sum of the rms value of the first six harmonics of the input signal to the rms value of the input signal.

PIN ASSIGNMENTS

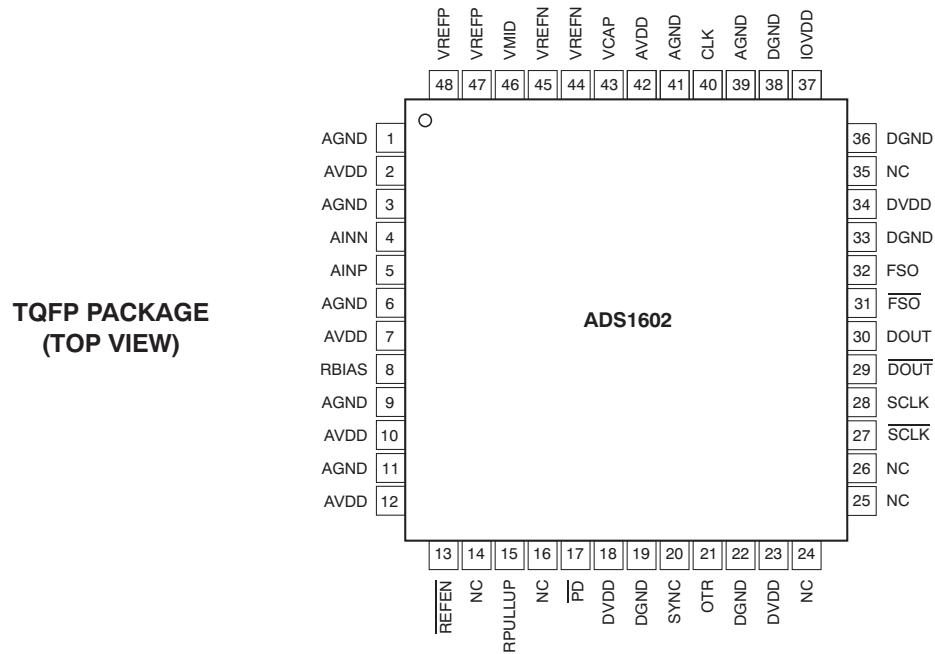

TERMINAL FUNCTIONS

TERMINAL		FUNCTION	DESCRIPTION
NAME	NO.		
AGND	1, 3, 6, 9, 11, 39, 41	Analog	Analog ground
AVDD	2, 7, 10, 12, 42	Analog	Analog supply
AINN	4	Analog input	Negative analog input
AINP	5	Analog input	Positive analog input
RBIAS	8	Analog	Terminal for external analog bias setting resistor.
REFEN	13	Digital input: active low	Internal reference enable. Internal pull-down resistor of 170kΩ to DGND.
NC	14, 16, 24–26, 35	Do not connect	These terminals must be left unconnected.
RPULLUP	15	Digital input	Pull-up to DVDD with 10kΩ resistor (see Figure 53).
PD	17	Digital input: active low	Power-down all circuitry. Internal pull-up resistor of 170kΩ to DGND.
DVDD	18, 23, 34	Digital	Digital supply
DGND	19, 22, 33, 36, 38	Digital	Digital ground
SYNC	20	Digital input	Synchronization control input
OTR	21	Digital output	Indicates analog input signal is out of range.
SCLK	28	Digital output	Serial clock output
SCLK	27	Digital output	Serial clock output, complementary signal.
DOUT	30	Digital output	Data output
DOUT	29	Digital output	Data output, complementary signal.
FSO	32	Digital output	Frame synchronization output
FSO	31	Digital output	Frame synchronization output, complementary signal.
IOVDD	37	Digital	Digital I/O supply
CLK	40	Digital input	Clock input
VCAP	43	Analog	Terminal for external bypass capacitor connection to internal bias voltage.
VREFN	44, 45	Analog	Negative reference voltage
VMID	46	Analog	Midpoint voltage
VREFP	47, 48	Analog	Positive reference voltage

TIMING DIAGRAMS

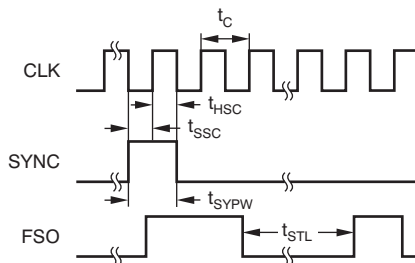

Figure 1. Initialization Timing

TIMING REQUIREMENTS

For $T_A = -40^\circ\text{C}$ to $+85^\circ\text{C}$, $DVDD = 2.7\text{V}$ to 3.6V , and $IOVDD = 2.7\text{V}$ to 5.25V .

SYMBOL	DESCRIPTION	MIN	TYP	MAX	UNIT
t_{SYPW}	SYNC positive pulse width	1			CLK period
t_c	Clock period (CLK)	25			ns
t_{SSC}	Setup time; SYNC rising edge to CLK rising edge	0.5			CLK period
t_{HSC}	Hold time; CLK rising edge to SYNC falling edge	0.5			CLK period
t_{STL}	Settling time of the ADS1602; FSO falling edge to next FSO rising edge			833	CLK periods

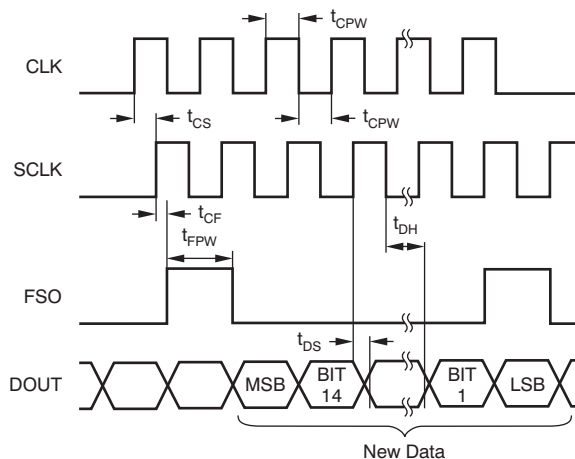

Figure 2. Data Retrieval Timing

TIMING REQUIREMENTS

For $T_A = -40^\circ\text{C}$ to $+85^\circ\text{C}$, $DVDD = 2.7\text{V}$ to 3.6V , and $IOVDD = 2.7\text{V}$ to 5.25V .

SYMBOL	DESCRIPTION	MIN	TYP	MAX	UNIT
t_{CS}	Rising edge of CLK to rising edge of SCLK			15	ns
t_{CF}	Rising edge of SCLK to rising edge of FSO			5	ns
t_{CPW}	CLK positive or negative pulse width	11.25			ns
t_{FPW}	Frame sync output high pulse width		1		CLK period
t_{DS}	SCLK rising edge to new DOUT valid			5	ns
t_{DH}	SCLK falling edge to DOUT invalid	6			ns

TYPICAL CHARACTERISTICS

All specifications at $T_A = +25^\circ\text{C}$, $AV_{DD} = 5\text{V}$, $DV_{DD} = IO_{VDD} = 3\text{V}$, $f_{CLK} = 40\text{MHz}$, External $V_{REF} = +3\text{V}$, $V_{CM} = +1.45\text{V}$, and $R_{BIAS} = 37\text{k}\Omega$, unless otherwise noted.

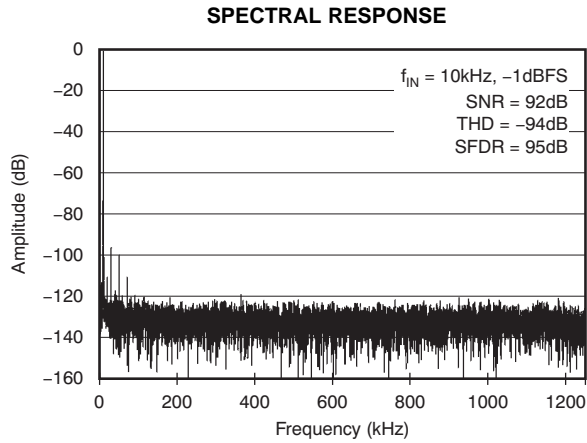

Figure 3.

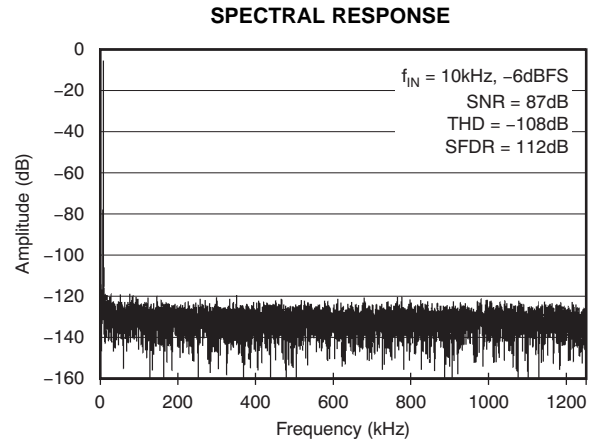

Figure 4.

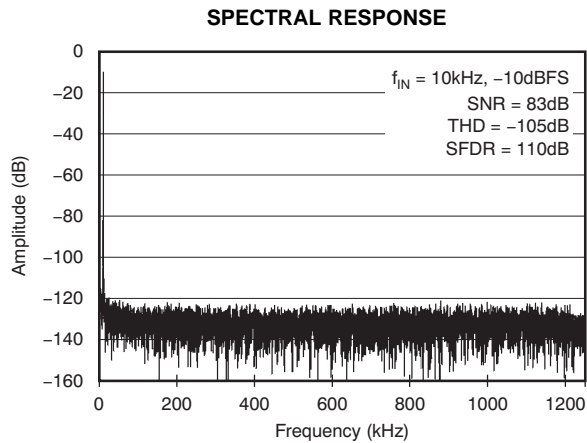

Figure 5.

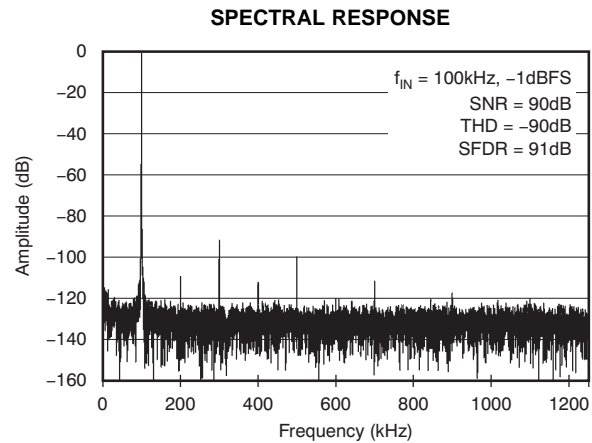

Figure 6.

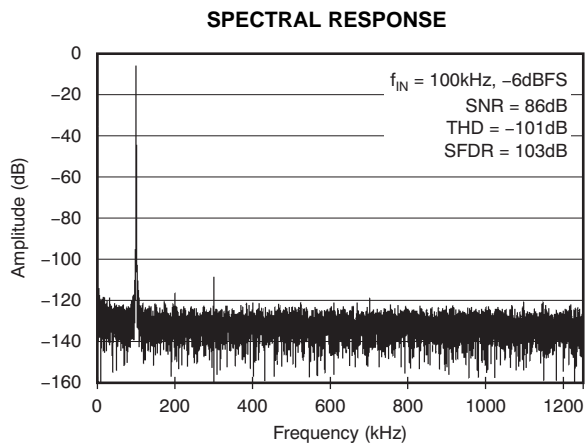

Figure 7.

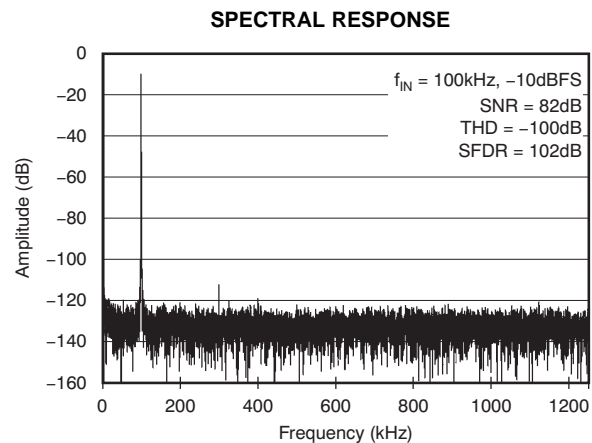

Figure 8.

TYPICAL CHARACTERISTICS (continued)

All specifications at $T_A = +25^\circ\text{C}$, $V_{DD} = 5\text{V}$, $DV_{DD} = IOV_{DD} = 3\text{V}$, $f_{\text{CLK}} = 40\text{MHz}$, External $V_{\text{REF}} = +3\text{V}$, $V_{\text{CM}} = +1.45\text{V}$, and $R_{\text{BIAS}} = 37\text{k}\Omega$, unless otherwise noted.

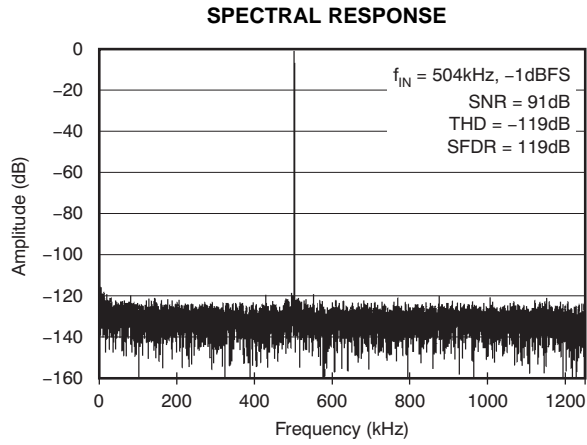

Figure 9.

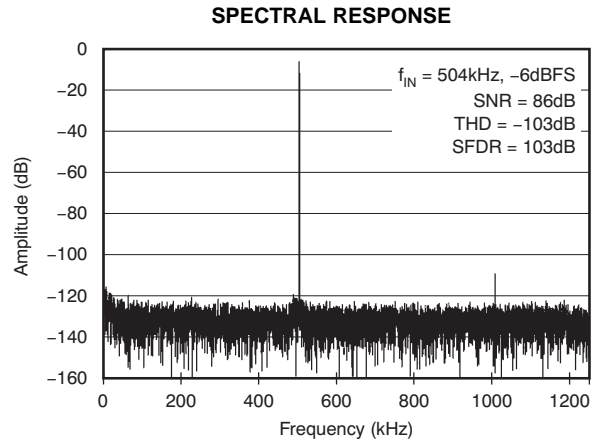

Figure 10.

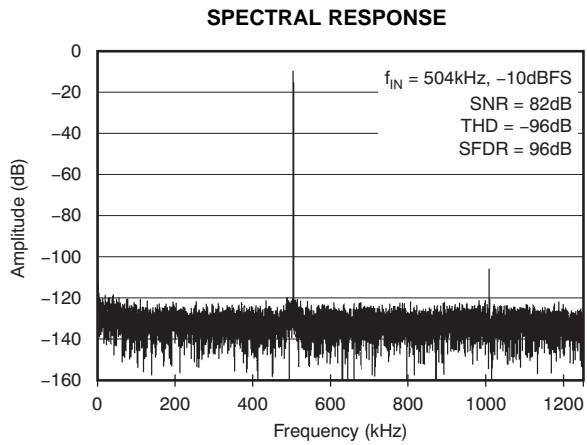

Figure 11.

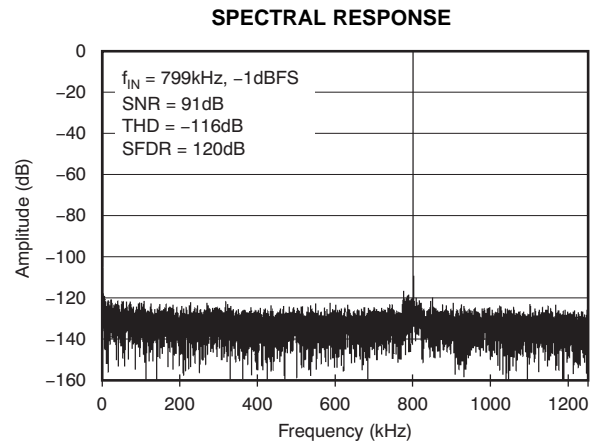

Figure 12.

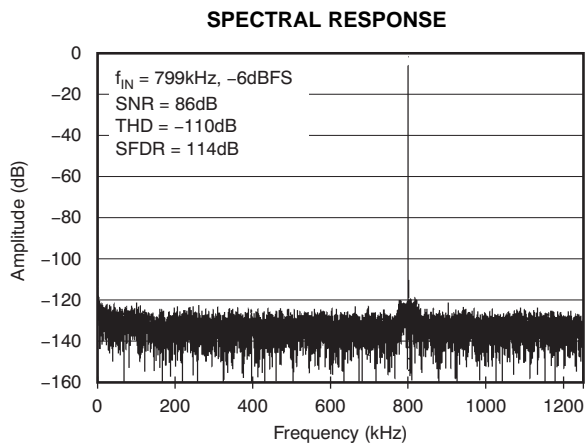

Figure 13.

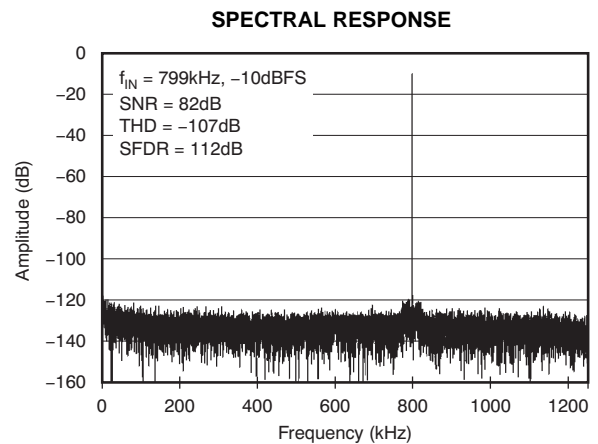

Figure 14.

TYPICAL CHARACTERISTICS (continued)

All specifications at $T_A = +25^\circ\text{C}$, $AV_{DD} = 5\text{V}$, $DV_{DD} = IOV_{DD} = 3\text{V}$, $f_{CLK} = 40\text{MHz}$, External $V_{REF} = +3\text{V}$, $V_{CM} = +1.45\text{V}$, and $R_{BIAS} = 37\text{k}\Omega$, unless otherwise noted.

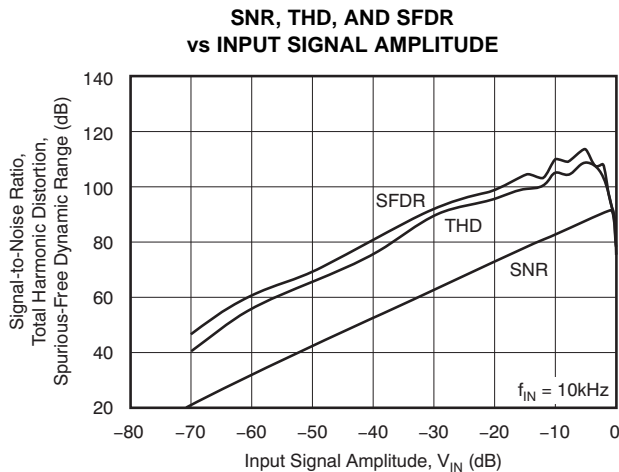

Figure 15.

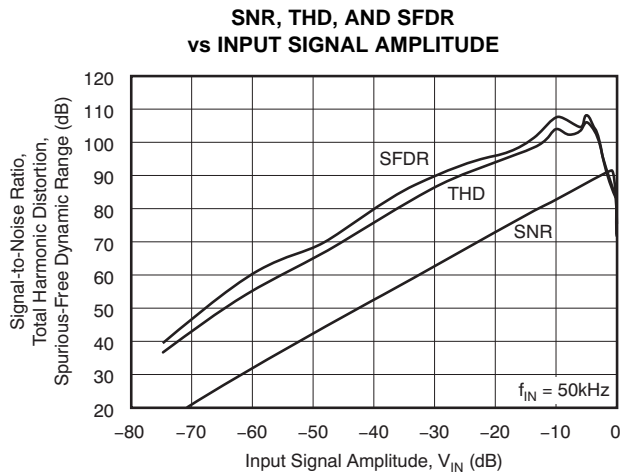

Figure 16.

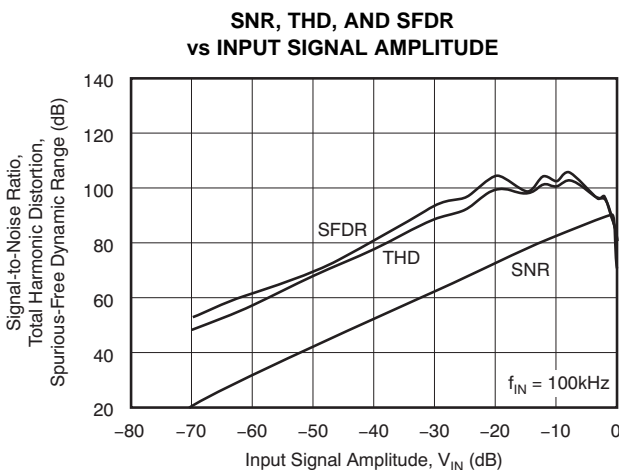

Figure 17.

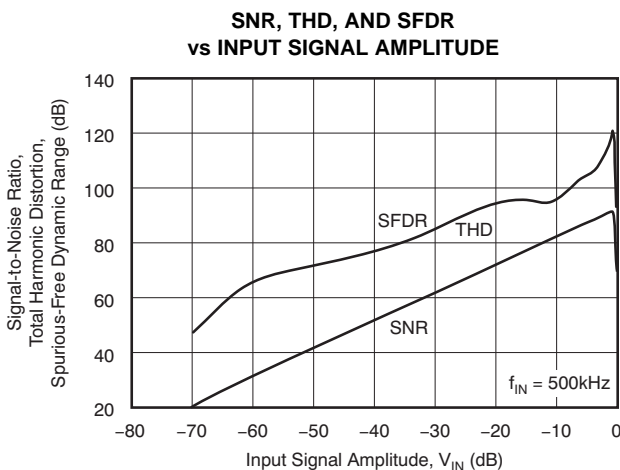

Figure 18.

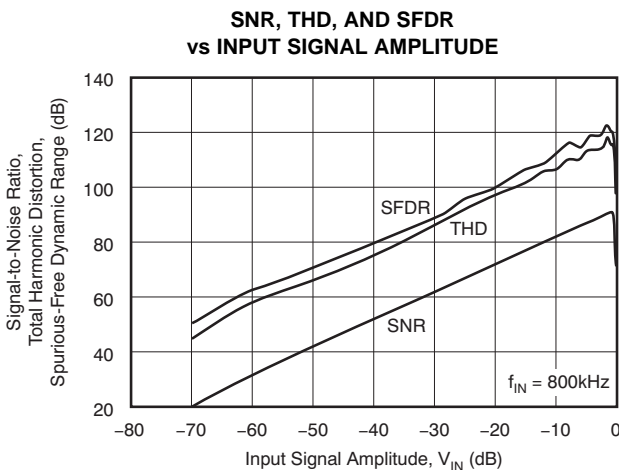

Figure 19.

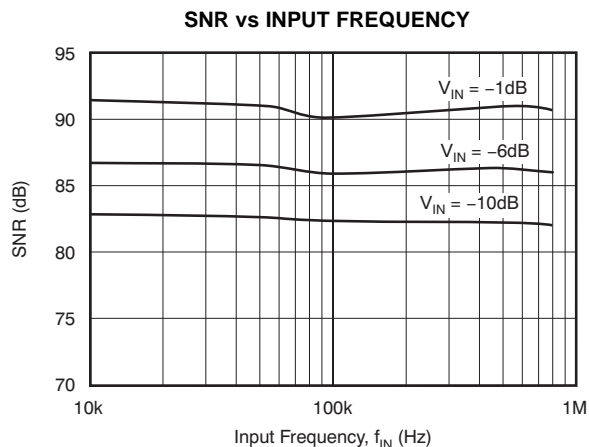

Figure 20.

TYPICAL CHARACTERISTICS (continued)

All specifications at $T_A = +25^\circ\text{C}$, $AV_{DD} = 5\text{V}$, $DV_{DD} = IO_{VDD} = 3\text{V}$, $f_{CLK} = 40\text{MHz}$, External $V_{REF} = +3\text{V}$, $V_{CM} = +1.45\text{V}$, and $R_{BIAS} = 37\text{k}\Omega$, unless otherwise noted.

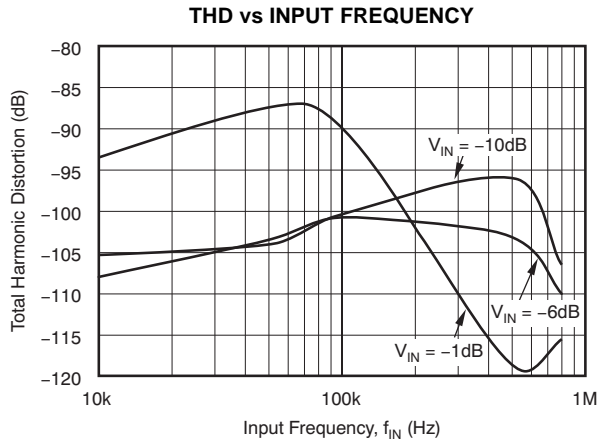

Figure 21.

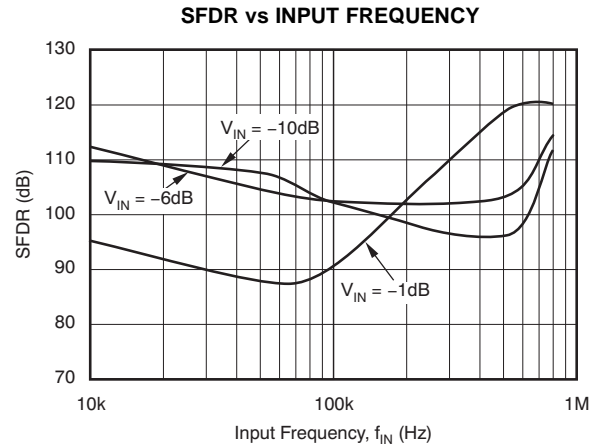

Figure 22.

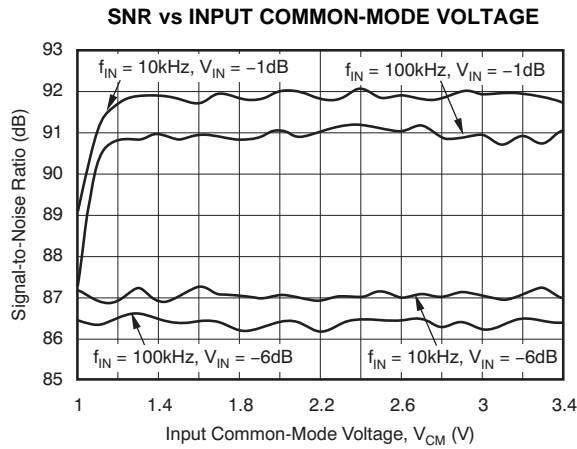

Figure 23.

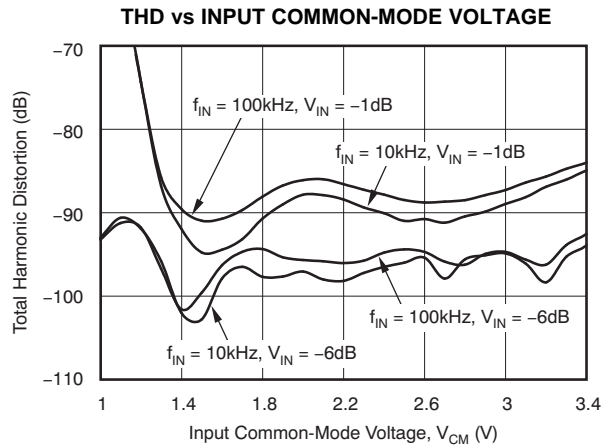

Figure 24.

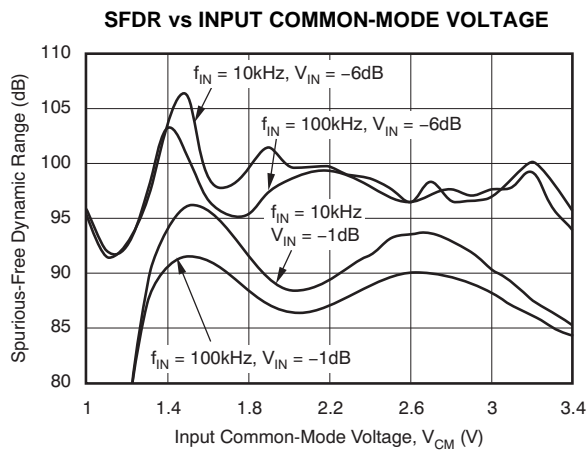

Figure 25.

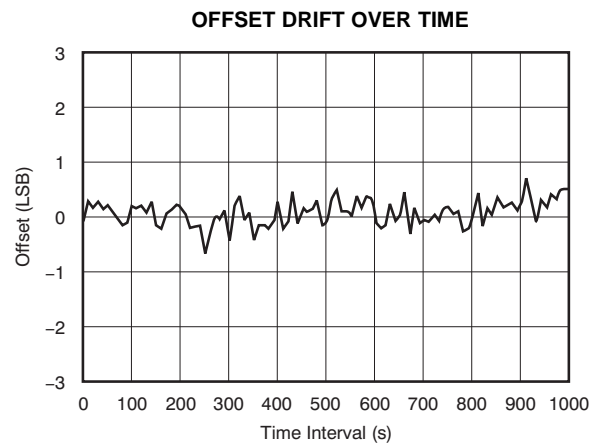

Figure 26.

TYPICAL CHARACTERISTICS (continued)

All specifications at $T_A = +25^\circ\text{C}$, $AVDD = 5\text{V}$, $DVDD = IOVDD = 3\text{V}$, $f_{\text{CLK}} = 40\text{MHz}$, External $V_{\text{REF}} = +3\text{V}$, $V_{\text{CM}} = +1.45\text{V}$, and $R_{\text{BIAS}} = 37\text{k}\Omega$, unless otherwise noted.

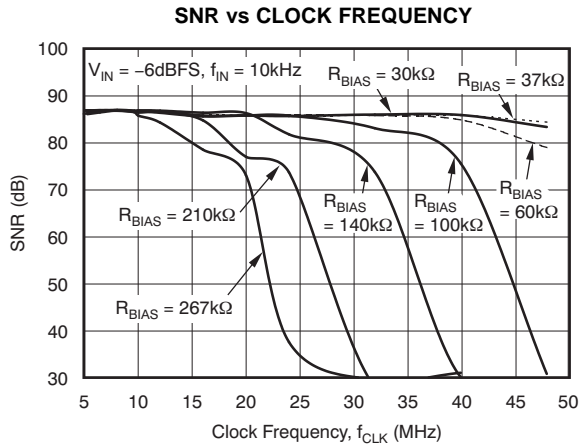

Figure 27.

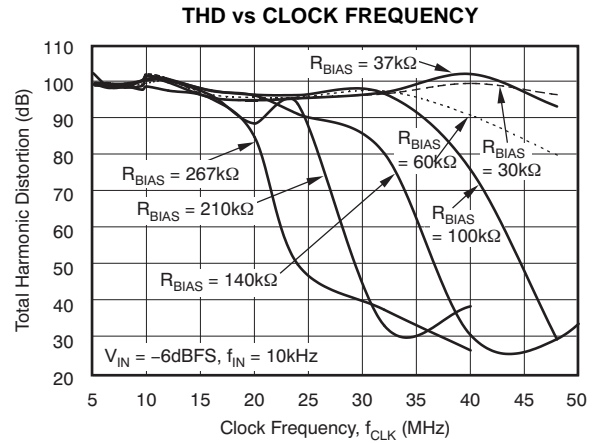

Figure 28.

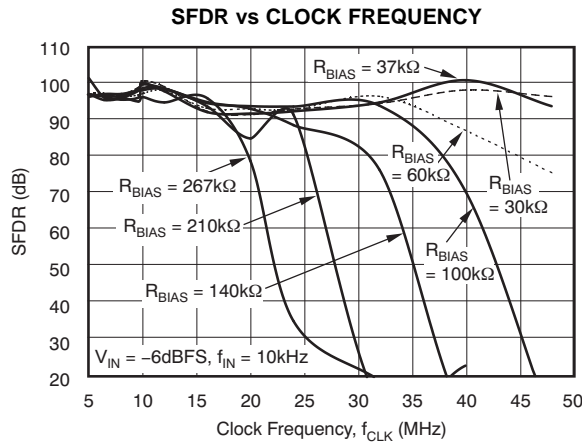

Figure 29.

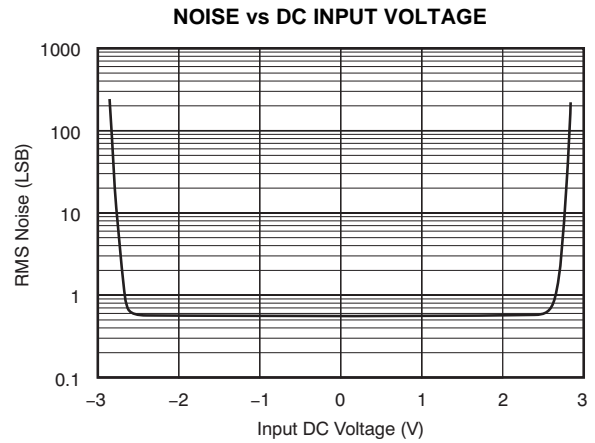

Figure 30.

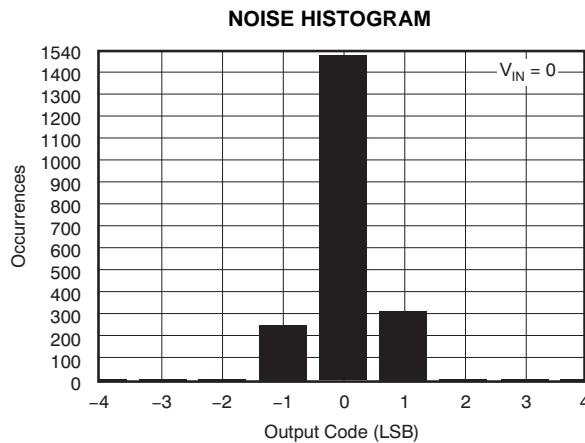

Figure 31.

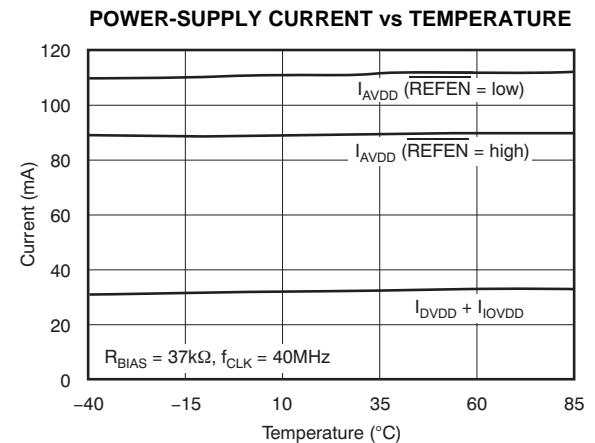

Figure 32.

TYPICAL CHARACTERISTICS (continued)

All specifications at $T_A = +25^\circ\text{C}$, $A_{VDD} = 5\text{V}$, $D_{VDD} = I_{O_{VDD}} = 3\text{V}$, $f_{CLK} = 40\text{MHz}$, External $V_{REF} = +3\text{V}$, $V_{CM} = +1.45\text{V}$, and $R_{BIAS} = 37\text{k}\Omega$, unless otherwise noted.

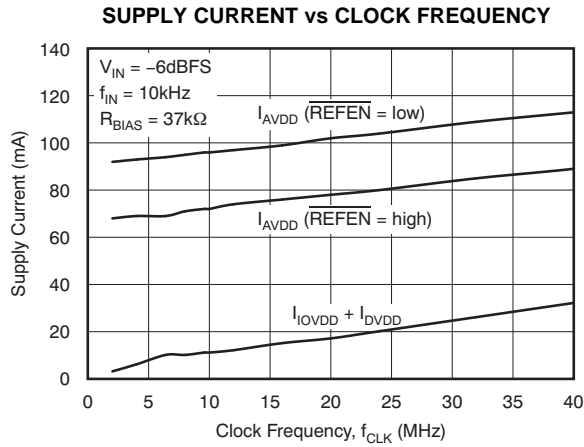

Figure 33.

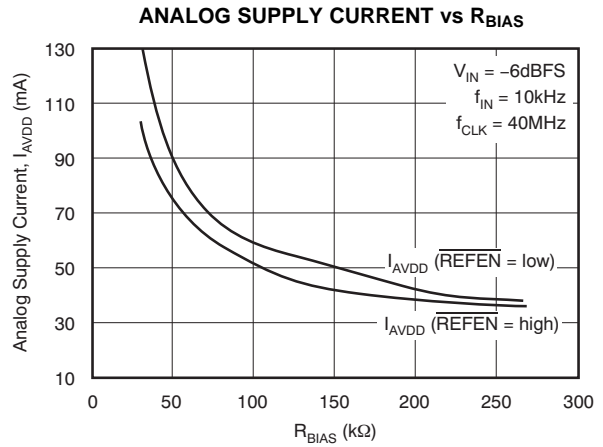

Figure 34.

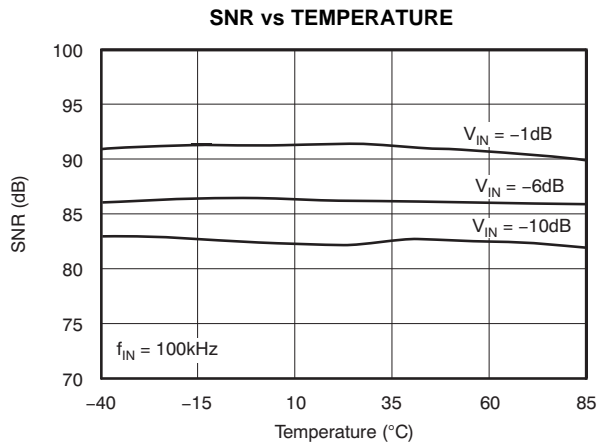

Figure 35.

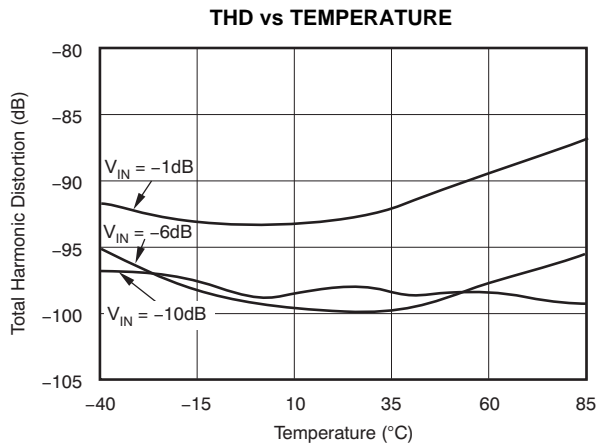

Figure 36.

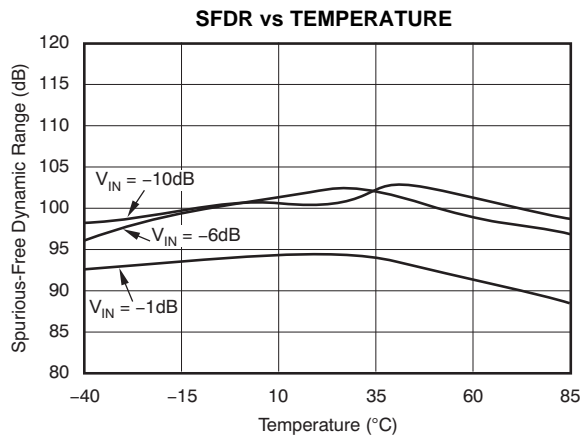

Figure 37.

OVERVIEW

The ADS1602 is a high-performance delta-sigma ($\Delta\Sigma$) analog-to-digital converter (ADC). The modulator uses an inherently stable 2-1-1 multi-stage architecture incorporating proprietary circuitry that allows for very linear high-speed operation. The modulator samples the input signal at 40MSPS (when $f_{CLK} = 40\text{MHz}$). A low-ripple linear phase digital filter decimates the modulator output by 16 to provide high resolution 16-bit output data.

Conceptually, the modulator and digital filter measure the differential input signal, $V_{IN} = (A_{INP} - A_{INN})$, against the scaled differential reference, $V_{REF} = (V_{REFP} - V_{REFN})$, as shown in Figure 38. The voltage reference can either be generated internally or supplied externally. A three-wire serial interface, designed for direct connection to DSPs, outputs the data. A separate power supply for the I/O allows flexibility for interfacing to different logic families. Out-of-range conditions are indicated with a dedicated digital output pin. Analog power dissipation is controlled using an external resistor. This control allows reduced dissipation when operating at slower speeds. When not in use, power consumption can be dramatically reduced by setting the \overline{PD} pin low to enter Power-Down mode.

ANALOG INPUTS (A_{INP}, A_{INN})

The ADS1602 measures the differential signal, $V_{IN} = (A_{INP} - A_{INN})$, against the differential reference, $V_{REF} = (V_{REFP} - V_{REFN})$. The most positive measurable differential input is V_{REF} , which produces the most positive digital output code of 7FFFh. Likewise, the most negative measurable differential input is $-V_{REF}$, which produces the most negative digital output code of 8000h.

The ADS1602 supports a very wide range of input signals. For $V_{REF} = 3\text{V}$, the full-scale input voltages are $\pm 3\text{V}$. Having such a wide input range makes out-of-range signals unlikely. However, should an out-of-range signal occur, the digital output OTR goes high.

The analog inputs must be driven with a differential signal to achieve optimum performance. For the input signal:

$$V_{CM} = \frac{A_{INP} + A_{INN}}{2}$$

the recommended common-mode voltage is 1.5V. In addition to the differential and common-mode input voltages, the absolute input voltage is also important. This is the voltage on either input (A_{INP} or A_{INN}) with respect to AGND. The range for this voltage is:

$$-0.1\text{V} < (A_{INN} \text{ or } A_{INP}) < 4.6\text{V}$$

If either input is taken below -0.1V , ESD protection diodes on the inputs will turn on. Exceeding 4.6V on either input results in degradation in the linearity performance. ESD protection diodes will also turn on if the inputs are taken above AVDD (+5V).

The recommended absolute input voltage is:

$$-0.1\text{V} < (A_{INN} \text{ or } A_{INP}) < 4.2\text{V}$$

Keeping the inputs within this range provides for optimum performance.

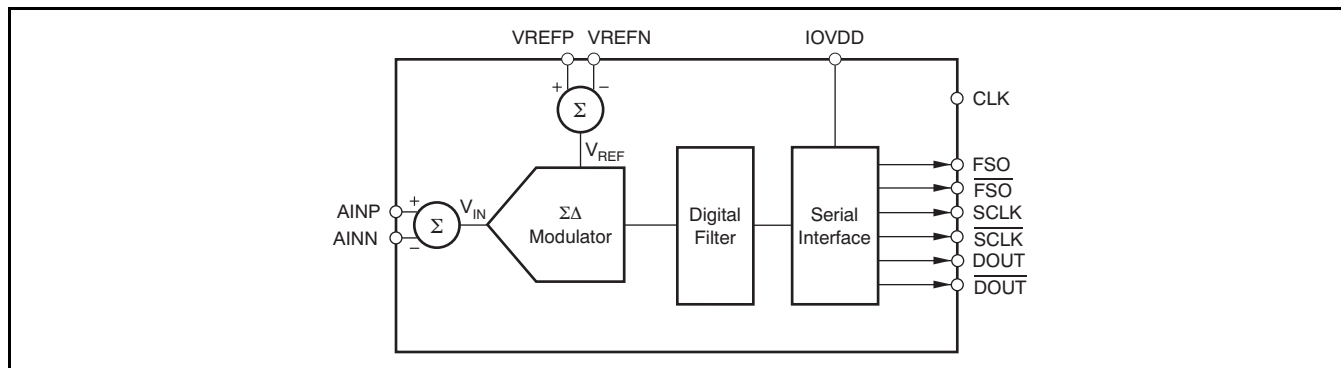

Figure 38. Conceptual Block Diagram

INPUT CIRCUITRY

The ADS1602 uses switched-capacitor circuitry to measure the input voltage. Internal capacitors are charged by the inputs and then discharged internally with this cycle repeating at the frequency of CLK. Figure 39 shows a conceptual diagram of these circuits. Switches S_2 represent the net effect of the modulator circuitry in discharging the sampling capacitors; the actual implementation is different. The timing for switches S_1 and S_2 is shown in Figure 40.

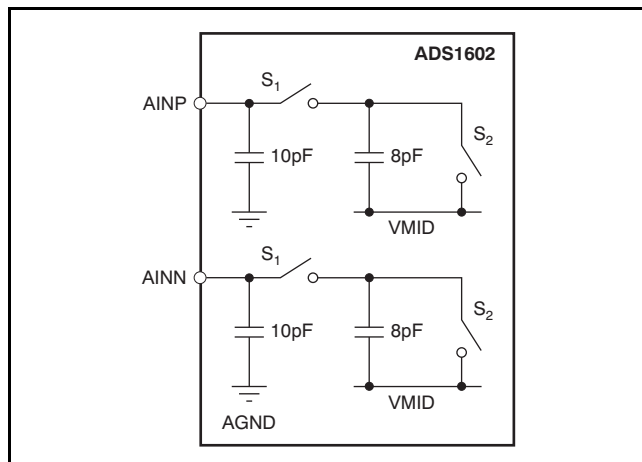

Figure 39. Conceptual Diagram of Internal Circuitry Connected to the Analog Inputs

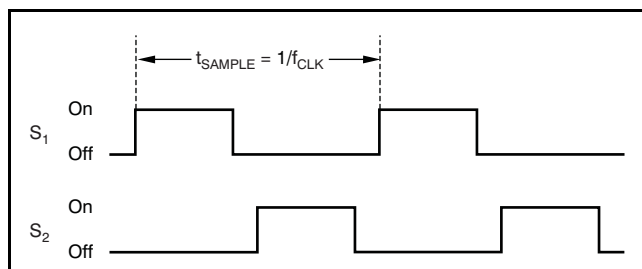

Figure 40. Timing for the Switches in Figure 39

DRIVING THE INPUTS

The external circuits driving the ADS1602 inputs must be able to handle the load presented by the switching capacitors within the ADS1602. The input switches S_1 in Figure 39 are closed for approximately one-half of the sampling period, t_{SAMPLE} , allowing only ≈ 11 ns for the internal capacitors to be charged by the inputs when $f_{CLK} = 40$ MHz.

Figure 41 and Figure 42 show the recommended circuits when using single-ended or differential op amps, respectively. The analog inputs must be driven differentially to achieve optimum performance. The external capacitors, between the inputs and from each input to AGND, improve linearity and should be placed as close to the pins as possible. Place the

drivers close to the inputs and use good capacitor bypass techniques on the supplies, such as a smaller high-quality ceramic capacitor in parallel with a larger capacitor. Keep the resistances used in the driver circuits low—thermal noise in the driver circuits degrades the overall noise performance. When the signal can be ac-coupled to the ADS1602 inputs, a simple RC filter can set the input common-mode voltage. The ADS1602 is a high-speed, high-performance ADC. Special care must be taken when selecting the test equipment and setup used with this device. Pay particular attention to the signal sources to ensure they do not limit performance when measuring the ADS1602.

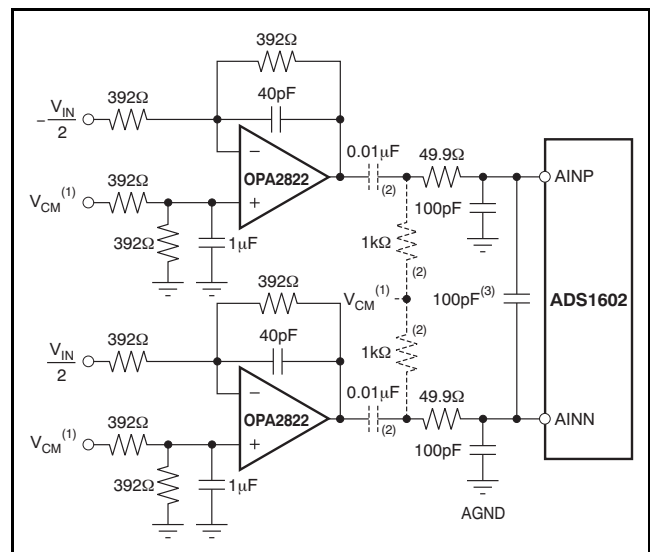

- (1) Recommended $V_{CM} = 1.5$ V.
- (2) Optional ac-coupling circuit provides common-mode input voltage.
- (3) Increase to 390pF when $f_{IN} \leq 100$ kHz for improved SNR and THD.

Figure 41. Recommended Driver Circuit Using the OPA2822

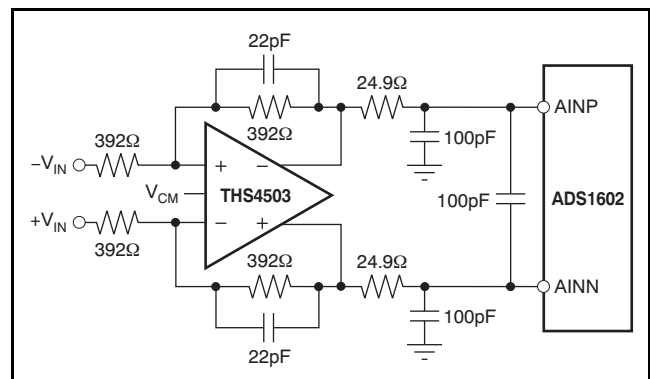

Figure 42. Recommended Driver Circuit Using the THS4503 Differential Amplifier

REFERENCE INPUTS (VREFN, VREFP, VMID)

The ADS1602 can operate from an internal or external voltage reference. In either case, the reference voltage V_{REF} is set by the differential voltage between VREFN and VREFP: $V_{REF} = (VREFP - VREFN)$. VREFP and VREFN each use two pins, which should be shorted together. VMID equals approximately 2.5V and is used by the modulator. VCAP connects to an internal node and must also be bypassed with an external capacitor.

INTERNAL REFERENCE ($\overline{REFEN} = \text{LOW}$)

To use the internal reference, set the \overline{REFEN} pin low. This activates the internal circuitry that generates the reference voltages. The internal reference voltages are applied to the pins. Good bypassing of the reference pins is critical to achieve optimum performance and is done by placing the bypass capacitors as close to the pins as possible. Figure 43 shows the recommended bypass capacitor values. Use high-quality ceramic capacitors for the smaller values. Avoid loading the internal reference with external circuitry. If the ADS1602 internal reference is to be used by other circuitry, buffer the reference voltages to prevent directly loading the reference pins.

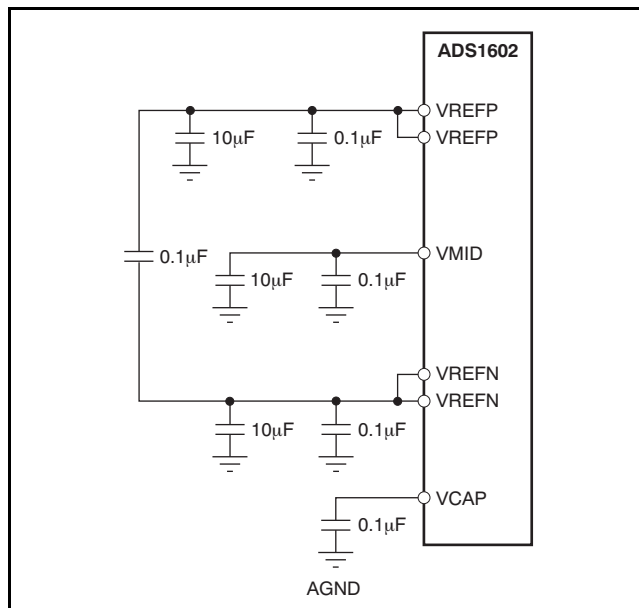

Figure 43. Reference Bypassing When Using the Internal Reference

EXTERNAL REFERENCE ($\overline{REFEN} = \text{HIGH}$)

To use an external reference, set the \overline{REFEN} pin high. This deactivates the internal generators for VREFP, VREFN, and VMID, and saves approximately 25mA of current on the analog supply (AVDD). The voltages applied to these pins must be within the values specified in the [Electrical Characteristics](#) table. Typically, $VREFP = 4V$, $VMID = 2.5V$, and $VREFN = 1V$. The external circuitry must be capable of providing both a dc and a transient current. Figure 44 shows a simplified diagram of the internal circuitry of the reference when the internal reference is disabled. As with the input circuitry, switches S_1 and S_2 open and close as shown by the timing in Figure 40.

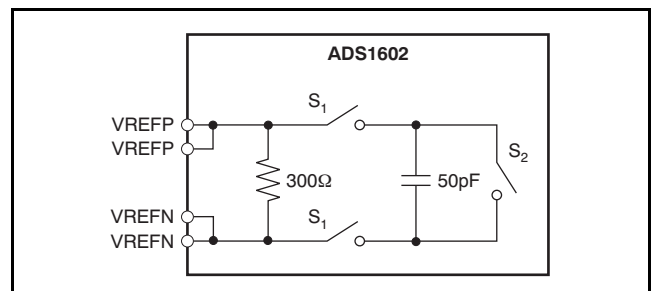

Figure 44. Conceptual Internal Circuitry for the Reference When $\overline{REFEN} = \text{HIGH}$

Figure 45 shows the recommended circuitry for driving these reference inputs. Keep the resistances used in the buffer circuits low to prevent excessive thermal noise from degrading performance. Layout of these circuits is critical; be sure to follow good high-speed layout practices. Place the buffers, and especially the bypass capacitors, as close to the pins as possible. VCAP is unaffected by the setting on \overline{REFEN} and must be bypassed when using the internal or an external reference.

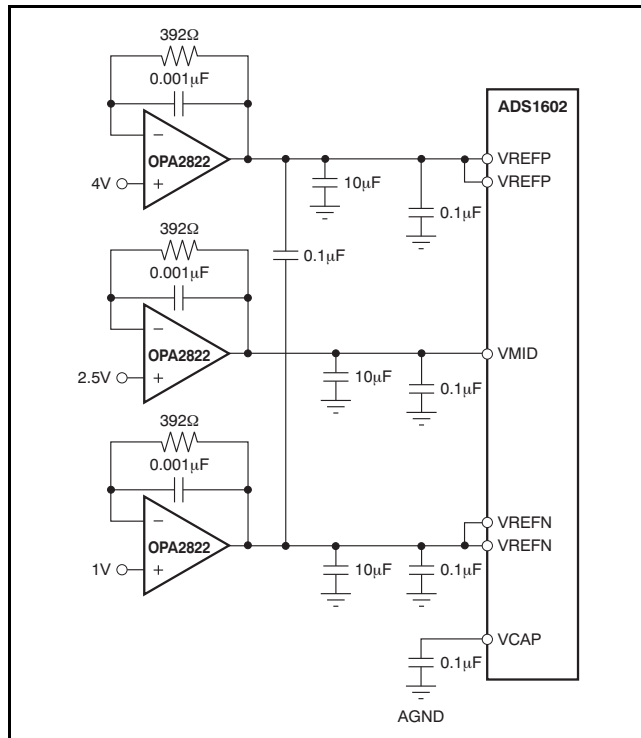

Figure 45. Recommended Buffer Circuit When Using an External Reference

CLOCK INPUT (CLK)

The ADS1602 requires an external clock signal to be applied to the CLK input pin. The sampling of the modulator is controlled by this clock signal. As with any high-speed data converter, a high quality clock is essential for optimum performance. Crystal clock oscillators are the recommended CLK source; other sources, such as frequency synthesizers, are usually inadequate. Make sure to avoid excess ringing on the CLK input; keeping the trace as short as possible helps.

Measuring high-frequency, large amplitude signals requires tight control of clock jitter. The uncertainty during sampling of the input from clock jitter limits the maximum achievable SNR. This effect becomes more pronounced with higher frequency and larger magnitude inputs. Fortunately, the ADS1602 oversampling topology reduces clock jitter sensitivity over that of Nyquist rate converters such as pipeline and successive approximation converters by a factor of $\sqrt{16}$.

In order to not limit the ADS1602 SNR performance, keep the jitter on the clock source below the values shown in Table 1. When measuring lower frequency and lower amplitude inputs, more CLK jitter can be tolerated. In determining the allowable clock source jitter, select the worst-case input (highest frequency, largest amplitude) that will be seen in the application.

Table 1. Maximum Allowable Clock Source Jitter for Different Input Signal Frequencies and Amplitude

INPUT SIGNAL		MAXIMUM ALLOWABLE CLOCK SOURCE JITTER
MAXIMUM FREQUENCY	MAXIMUM AMPLITUDE	
1MHz	-2dB	3.8ps
1MHz	-20dB	28ps
500kHz	-2dB	7.6ps
500kHz	-20dB	57ps
100kHz	-2dB	38ps
100kHz	-20dB	285ps

DATA FORMAT

The 16-bit output data are in binary two's complement format as shown in Table 2. When the input is positive out-of-range, exceeding the positive full-scale value of V_{REF} , the output clips to all 7FFFh and the OTR output goes high.

Likewise, when the input is negative out-of-range by going below the negative full-scale value of $-V_{REF}$, the output clips to 8000h and the OTR output goes high. The OTR remains high while the input signal is out-of-range.

Table 2. Output Code versus Input Signal

INPUT SIGNAL (INP – INN)	IDEAL OUTPUT CODE ⁽¹⁾	OTR
$\geq +V_{REF}$ (> 0dB)	7FFFh	1
$-V_{REF}$ (0dB)	7FFFh	0
$\frac{+V_{REF}}{2^{15} - 1}$	0001h	0
0	0000h	0
$\frac{-V_{REF}}{2^{15} - 1}$	FFFFh	0
$-V_{REF} \left(\frac{2^{15}}{2^{15} - 1} \right)$	8000h	0
$-V_{REF} \left(\frac{2^{15}}{2^{15} - 1} \right)$	8000h	1

(1) Excludes effects of noise, INL, offset, and gain errors.

OUT-OF-RANGE INDICATION (OTR)

If the output code exceeds the positive or negative full-scale, the out-of-range digital output OTR will go high on the falling edge of SCLK. When the output code returns within the full-scale range, OTR returns low on the falling edge of SCLK.

DATA RETRIEVAL

Data retrieval is controlled through a simple serial interface. The interface operates in a master fashion by outputting both a frame sync indicator (FSO) and a serial clock (SCLK). Complementary outputs are provided for the frame sync output ($\overline{\text{FSO}}$), serial clock ($\overline{\text{SCLK}}$), and data output ($\overline{\text{DOUT}}$). When not needed, leave the complementary outputs unconnected.

INITIALIZING THE ADS1602

After the power supplies have stabilized, you must initialize the ADS1602 by issuing a SYNC pulse as shown in Figure 1. This operation needs only to be done once after power-up and does not need to be performed when exiting the Power-Down mode. Note that the ADS1602 silicon was revised in June 2006. The digital interface timing specifications were modified slightly from the previous revision. This data sheet reflects behavior of the latest revision. Contact the factory for more information on the previous revision.

SYNCHRONIZING MULTIPLE ADS1602s

The SYNC input can be used to synchronize multiple ADS1602s to provide simultaneous sampling. All devices to be synchronized must use a common CLK input. With the CLK inputs running, pulse SYNC on the falling edge of CLK, as shown in Figure 46. Afterwards, the converters will be converting synchronously with the FSO outputs updating simultaneously. After synchronization, FSO is held low until the digital filter has fully settled.

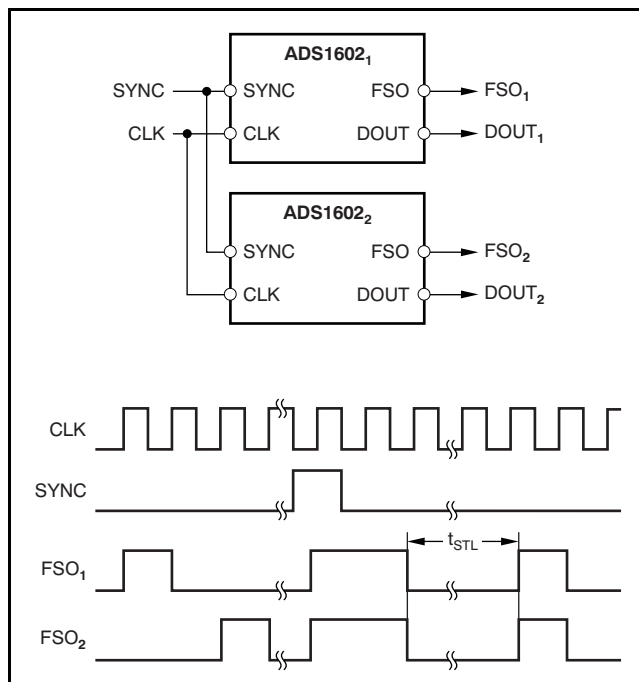

Figure 46. Synchronizing Multiple Converters

STEP RESPONSE

Figure 47 plots the normalized step response for an input applied at $t = 0$. The x-axis units of time are conversion cycles. It takes 51 cycles to fully settle; for $f_{\text{CLK}} = 40\text{MHz}$, this corresponds to $20.4\mu\text{s}$.

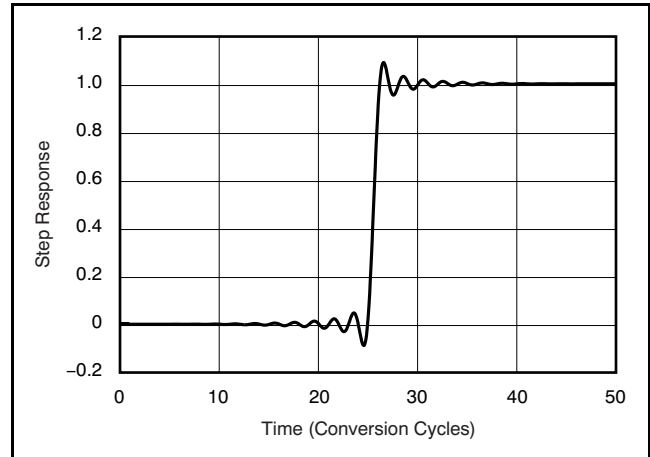

Figure 47. Step Response

FREQUENCY RESPONSE

The linear phase FIR digital filter sets the overall frequency response. Figure 48 shows the frequency response from dc to 20MHz for $f_{\text{CLK}} = 40\text{MHz}$. The frequency response of the ADS1602 filter scales directly with CLK frequency. For example, if the CLK frequency is decreased by half (to 20MHz), the values on the x-axis in Figure 48 would need to be scaled by half, with the span becoming dc to 10MHz.

Figure 49 shows the passband ripple from dc to 1200kHz ($f_{\text{CLK}} = 40\text{MHz}$). Figure 50 shows a closer view of the passband transition by plotting the response from 900kHz to 1300kHz ($f_{\text{CLK}} = 40\text{MHz}$).

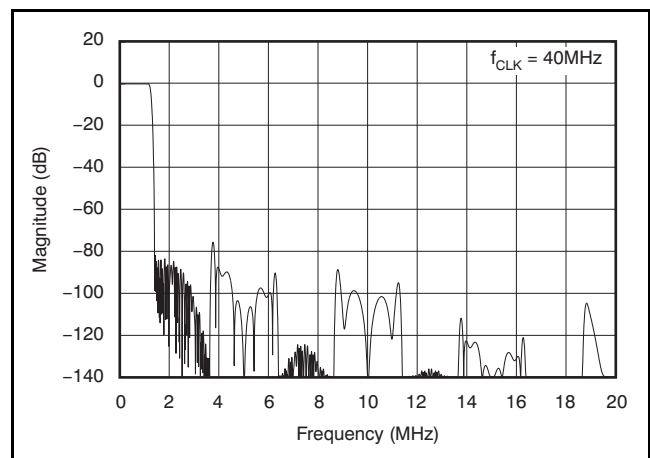

Figure 48. Frequency Response

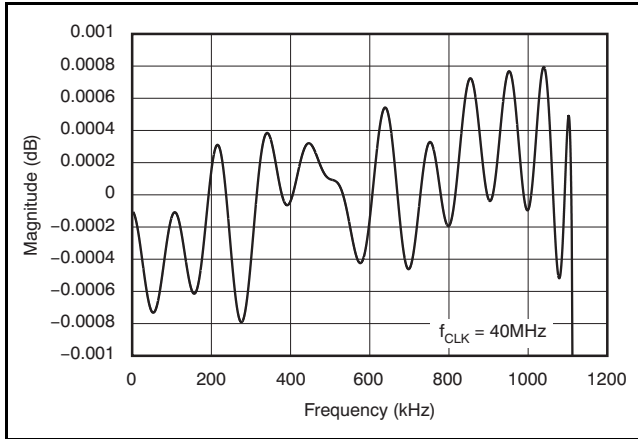

Figure 49. Passband Ripple

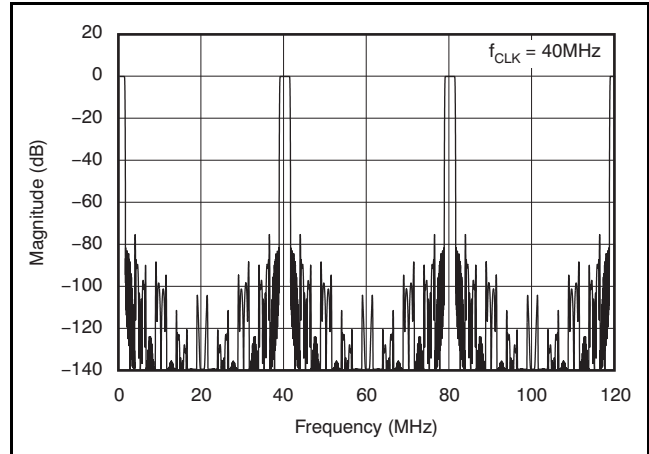

Figure 51. Frequency Response Out to 120MHz

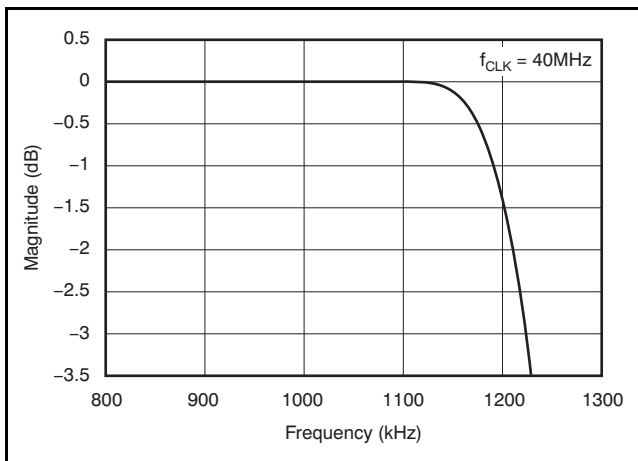

Figure 50. Passband Transition

ANTIALIAS REQUIREMENTS

Higher frequency, out-of-band signals must be eliminated to prevent aliasing with ADCs. Fortunately, the ADS1602 on-chip digital filter greatly simplifies this filtering requirement. Figure 51 shows the ADS1602 response out to 120MHz ($f_{CLK} = 40\text{MHz}$). Since the stop band extends out to 38.6MHz, the antialias filter in front of the ADS1602 only needs to be designed to remove higher frequency signals than this, which can usually be accomplished with a simple RC circuit on the input driver.

ANALOG POWER DISSIPATION

An external resistor connected between the R_{BIAS} pin and the analog ground sets the analog current level, as shown in Figure 52. The current is inversely proportional to the resistor value. Table 3 shows the recommended values of R_{BIAS} for different CLK frequencies. Notice that the analog current can be reduced when using a slower frequency CLK input because the modulator has more time to settle. Avoid adding any capacitance in parallel to R_{BIAS} because this interferes with the internal circuitry used to set the biasing. Please note that changing the R_{BIAS} resistor value changes all internally-generated bias voltages, including the internal reference; therefore, the recommendations in Table 3 are only for when using an external reference.

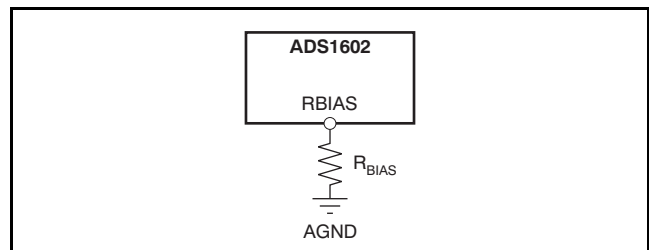

Figure 52. External Resistor Used to Set Analog Power Dissipation

Table 3. Recommended R_{BIAS} Resistor Values for Different CLK Frequencies

f_{CLK}	DATA RATE	R _{BIAS}	TYPICAL POWER DISSIPATION WITH REFEN HIGH
16MHz	1MSPS	140k Ω	200mW
24MHz	1.5MSPS	100k Ω	270mW
32MHz	2MSPS	60k Ω	390mW
40MHz	2.5MSPS	37k Ω	530mW

POWER DOWN (\overline{PD})

When not in use, the ADS1602 can be powered down by taking the \overline{PD} pin low. All circuitry is shut down, including the voltage reference. To minimize the digital current during power down, stop the clock signal supplied to the CLK input. There is an internal pull-up resistor of 170k Ω on the \overline{PD} pin, but it is recommended that this pin be connected to IOVDD if not used. Make sure to allow time for the reference to start up after exiting power-down mode. The internal reference typically requires 15ms. After the reference has stabilized, allow at least 100 conversions for the modulator and digital filter to settle before retrieving data.

POWER SUPPLIES

Three supplies are used on the ADS1602: analog (AVDD), digital (DVDD), and digital I/O (IOVDD). Each supply must be suitably bypassed to achieve the best performance. It is recommended that a 1 μ F and 0.1 μ F ceramic capacitor be placed as close to each supply pin as possible. Connect each supply-pin bypass capacitor to the associated ground, as shown in Figure 53. Each main supply bus should also be bypassed with a bank of capacitors from 47 μ F to 0.1 μ F, as shown. The I/O and digital supplies (IOVDD and DVDD) can be connected together when using the same voltage. In this case, only one bank of 47 μ F to 0.1 μ F capacitors is needed on the main supply bus, though each supply pin must still be bypassed with a 1 μ F and 0.1 μ F ceramic capacitor.

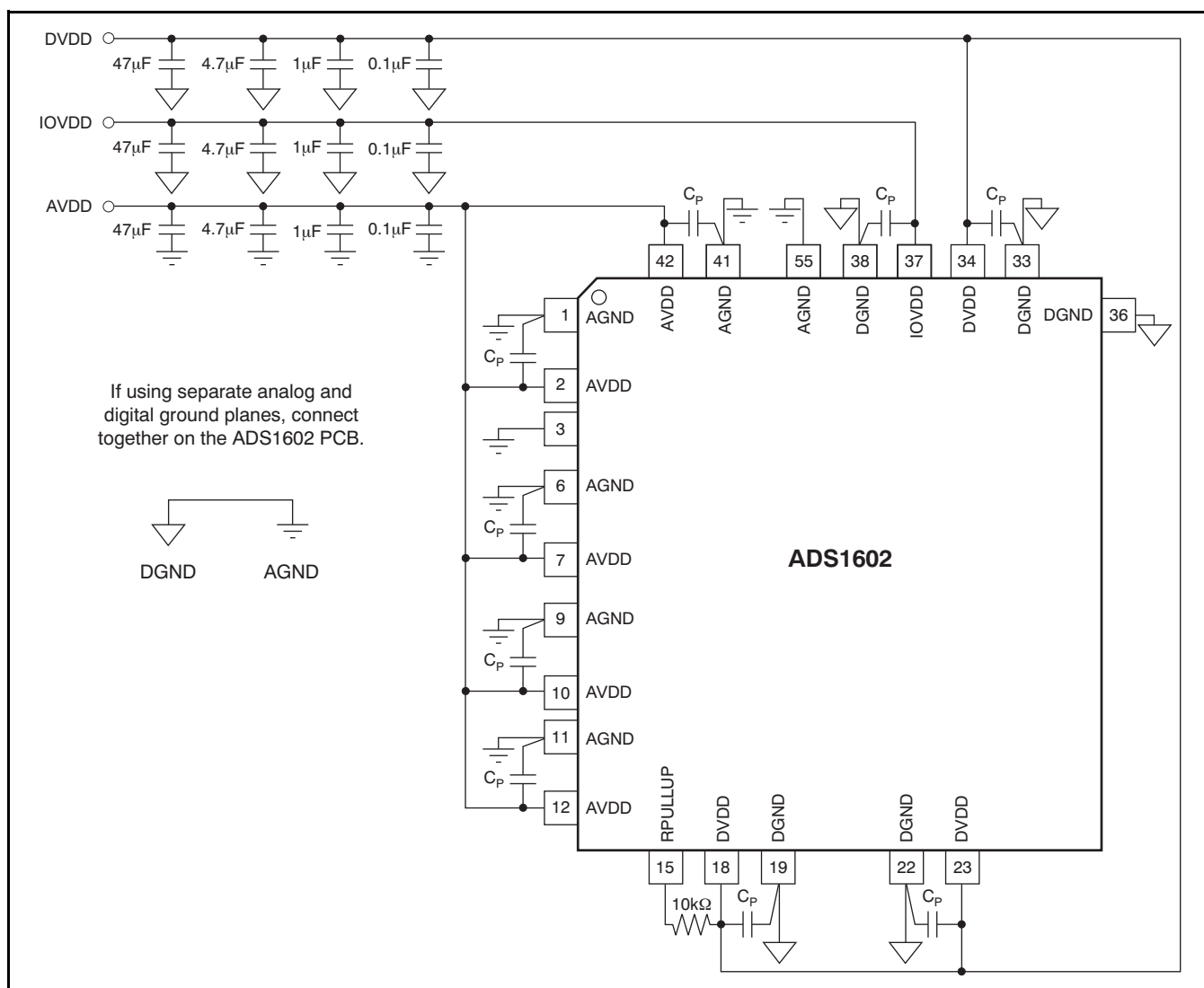

Figure 53. Recommended Power-Supply Bypassing

LAYOUT ISSUES AND COMPONENT SELECTION

The ADS1602 is a very high-speed, high-resolution data converter. In order to achieve maximum performance, the user must give very careful consideration to both the layout of the printed circuit board (PCB) in addition to the routing of the traces. Capacitors that are critical to achieve the best performance from the device should be placed as close to the pins of the device as possible. These include capacitors related to the analog inputs, the reference, and the power supplies.

For critical capacitors, it is recommended that Class II dielectrics such as Z5U be avoided. These dielectrics have a narrow operating temperature, a large tolerance on the capacitance, and lose up to 20% of the rated capacitance over 10,000 hours. Rather, select capacitors with a Class I dielectric. C0G (also known as NP0), for example, has a tight tolerance less than $\pm 30\text{ppm}/^\circ\text{C}$ and is very stable over time. Should Class II capacitors be chosen because of the size constraints, select an X7R or X5R dielectric to minimize the variations of the capacitor's critical characteristics.

The resistors used in the circuits to drive the input and reference should be kept as low as possible to prevent excess thermal noise from degrading the system performance.

The digital outputs from the device should always be buffered. This has a number of benefits: it reduces the loading of the internal digital buffers, which decreases noise generated within the device, and it also reduces device power consumption.

APPLICATIONS INFORMATION

Interfacing the ADS1602 to the TMS320 DSP family

Since the ADS1602 communicates with the host via a serial interface, the most suitable method to connect to any of the TMS320 DSPs is via the multi-channel buffered serial port (McBSP). A typical connection to the TMS320 DSP is shown in [Figure 54](#).

The McBSP provides a host of functions including:

- Full-duplex communication
- Double-buffered data registers
- Independent framing and clocking for reception and transmission of data

The sequence begins with a one-time synchronization of the serial port by the microprocessor. The ADS1602 recognizes the SYNC signal if it is high for at least one CLK period. Transfers are initiated by the ADS1602 after the SYNC signal is de-asserted by the microprocessor.

The FSO signal from the ADS1602 indicates that data is available to be read, and is connected to the frame sync receive (FSR) pin of the DSP. The clock receiver (CLKR) is derived directly from the ADS1602 serial clock output to ensure continued synchronization of data with the clock.

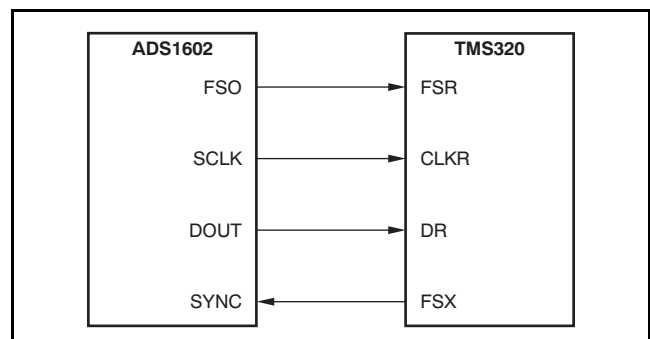

Figure 54. ADS1602—TMS320 Interface Connection

An evaluation module (EVM) is available from Texas Instruments. The module consists of the ADS1602 and supporting circuits, allowing users to quickly assess the performance and characteristics of the ADS1602. The EVM easily connects to various microcontrollers and DSP systems. For more details, or to download a copy of the [ADS1602EVM User's Guide](#), visit the Texas Instruments web site at www.ti.com.

REVISION HISTORY

NOTE: Page numbers for previous revisions may differ from page numbers in the current version.

Changes from Revision D (November 2010) to Revision E Page

- Added footnote to Electrical Characteristics table 4
-

Changes from Revision C (September 2010) to Revision D Page

- Changed t_C minimum specification in Timing Requirements table for [Figure 1](#) 8
 - Changed t_{CPW} minimum specification in Timing Requirements table for [Figure 2](#) 8
 - Changed t_{DH} minimum specification in Timing Requirements table for [Figure 2](#) 8
-

PACKAGING INFORMATION

Orderable Device	Status (1)	Package Type	Package Drawing	Pins	Package Qty	Eco Plan (2)	Lead/Ball Finish (6)	MSL Peak Temp (3)	Op Temp (°C)	Device Marking (4/5)	Samples
ADS1602IPFBR	ACTIVE	TQFP	PFB	48	1000	Green (RoHS & no Sb/Br)	CU NIPDAU	Level-2-260C-1 YEAR	-40 to 85	ADS1602I	Samples
ADS1602IPFBT	ACTIVE	TQFP	PFB	48	250	Green (RoHS & no Sb/Br)	CU NIPDAU	Level-2-260C-1 YEAR	-40 to 85	ADS1602I	Samples

(1) The marketing status values are defined as follows:

ACTIVE: Product device recommended for new designs.

LIFEBUY: TI has announced that the device will be discontinued, and a lifetime-buy period is in effect.

NRND: Not recommended for new designs. Device is in production to support existing customers, but TI does not recommend using this part in a new design.

PREVIEW: Device has been announced but is not in production. Samples may or may not be available.

OBSOLETE: TI has discontinued the production of the device.

(2) **RoHS:** TI defines "RoHS" to mean semiconductor products that are compliant with the current EU RoHS requirements for all 10 RoHS substances, including the requirement that RoHS substance do not exceed 0.1% by weight in homogeneous materials. Where designed to be soldered at high temperatures, "RoHS" products are suitable for use in specified lead-free processes. TI may reference these types of products as "Pb-Free".

RoHS Exempt: TI defines "RoHS Exempt" to mean products that contain lead but are compliant with EU RoHS pursuant to a specific EU RoHS exemption.

Green: TI defines "Green" to mean the content of Chlorine (Cl) and Bromine (Br) based flame retardants meet JS709B low halogen requirements of <=1000ppm threshold. Antimony trioxide based flame retardants must also meet the <=1000ppm threshold requirement.

(3) MSL, Peak Temp. - The Moisture Sensitivity Level rating according to the JEDEC industry standard classifications, and peak solder temperature.

(4) There may be additional marking, which relates to the logo, the lot trace code information, or the environmental category on the device.

(5) Multiple Device Markings will be inside parentheses. Only one Device Marking contained in parentheses and separated by a "-" will appear on a device. If a line is indented then it is a continuation of the previous line and the two combined represent the entire Device Marking for that device.

(6) Lead/Ball Finish - Orderable Devices may have multiple material finish options. Finish options are separated by a vertical ruled line. Lead/Ball Finish values may wrap to two lines if the finish value exceeds the maximum column width.

Important Information and Disclaimer:The information provided on this page represents TI's knowledge and belief as of the date that it is provided. TI bases its knowledge and belief on information provided by third parties, and makes no representation or warranty as to the accuracy of such information. Efforts are underway to better integrate information from third parties. TI has taken and continues to take reasonable steps to provide representative and accurate information but may not have conducted destructive testing or chemical analysis on incoming materials and chemicals. TI and TI suppliers consider certain information to be proprietary, and thus CAS numbers and other limited information may not be available for release.

In no event shall TI's liability arising out of such information exceed the total purchase price of the TI part(s) at issue in this document sold by TI to Customer on an annual basis.

TAPE AND REEL INFORMATION



QUADRANT ASSIGNMENTS FOR PIN 1 ORIENTATION IN TAPE



*All dimensions are nominal

Device	Package Type	Package Drawing	Pins	SPQ	Reel Diameter (mm)	Reel Width W1 (mm)	A0 (mm)	B0 (mm)	K0 (mm)	P1 (mm)	W (mm)	Pin1 Quadrant
ADS1602IPFBR	TQFP	PFB	48	1000	330.0	16.4	9.6	9.6	1.5	12.0	16.0	Q2
ADS1602IPFBT	TQFP	PFB	48	250	180.0	16.4	9.6	9.6	1.5	12.0	16.0	Q2

TAPE AND REEL BOX DIMENSIONS

*All dimensions are nominal

Device	Package Type	Package Drawing	Pins	SPQ	Length (mm)	Width (mm)	Height (mm)
ADS1602IPFBR	TQFP	PFB	48	1000	350.0	350.0	43.0
ADS1602IPFBT	TQFP	PFB	48	250	213.0	191.0	55.0

PFB (S-PQFP-G48)

PLASTIC QUAD FLATPACK

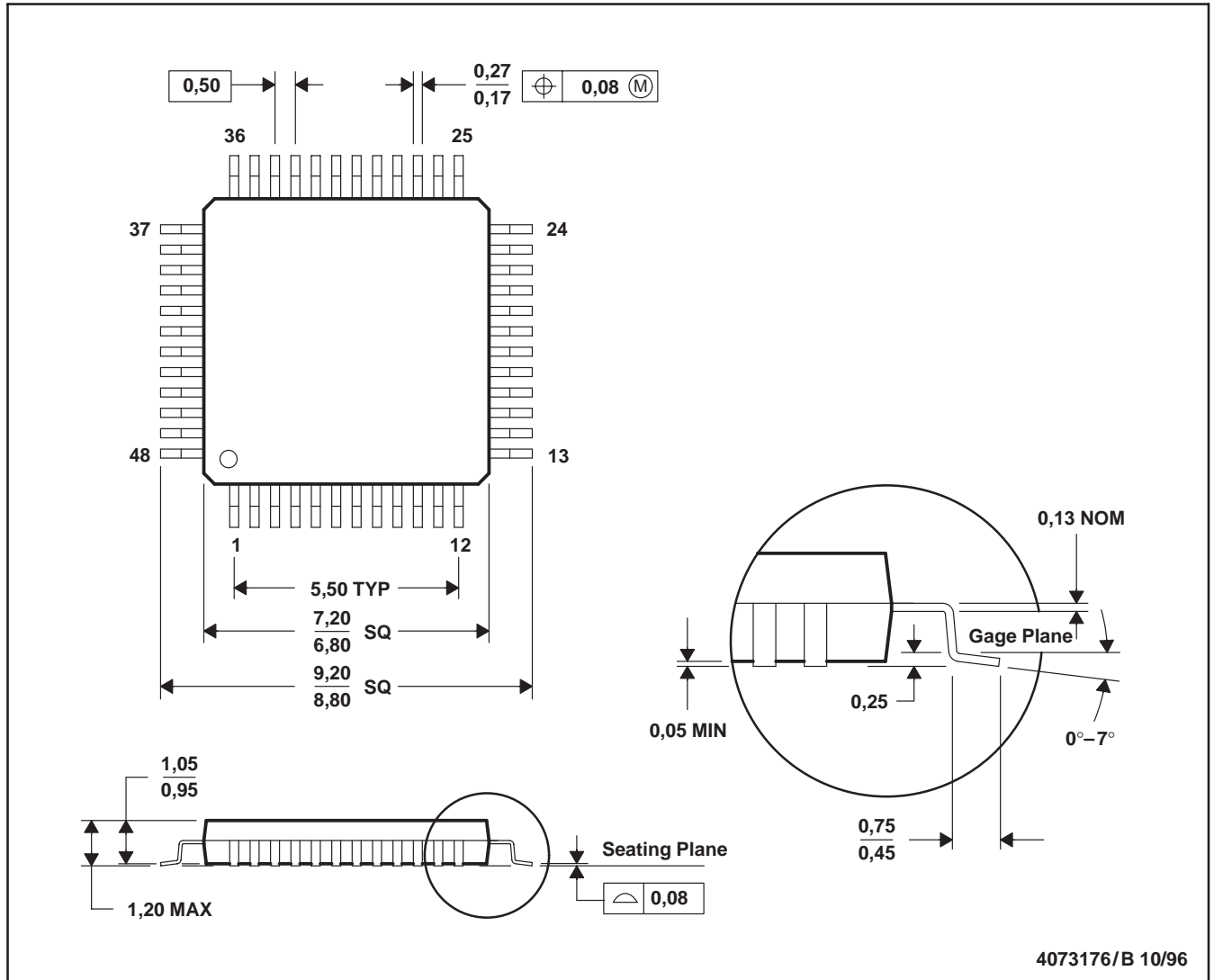

- NOTES: A. All linear dimensions are in millimeters.
 B. This drawing is subject to change without notice.
 C. Falls within JEDEC MS-026

PFB (S-PQFP-G48)

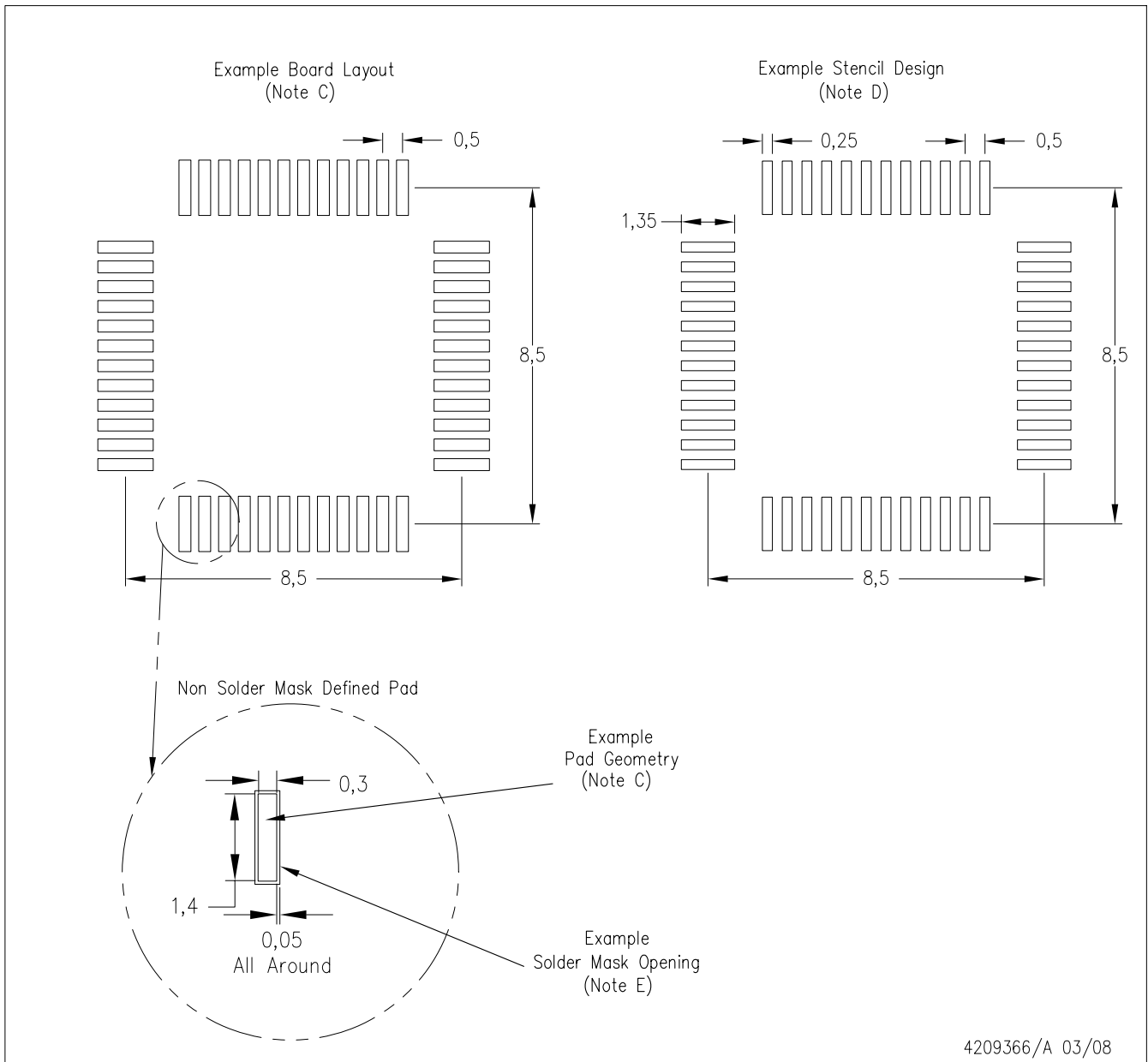

- NOTES:
- A. All linear dimensions are in millimeters.
 - B. This drawing is subject to change without notice.
 - C. Publication IPC-7351 is recommended for alternate designs.
 - D. Laser cutting apertures with trapezoidal walls and also rounding corners will offer better paste release. Customers should contact their board assembly site for stencil design recommendations. Refer to IPC-7525.
 - E. Customers should contact their board fabrication site for solder mask tolerances between and around signal pads.

IMPORTANT NOTICE AND DISCLAIMER

TI PROVIDES TECHNICAL AND RELIABILITY DATA (INCLUDING DATASHEETS), DESIGN RESOURCES (INCLUDING REFERENCE DESIGNS), APPLICATION OR OTHER DESIGN ADVICE, WEB TOOLS, SAFETY INFORMATION, AND OTHER RESOURCES "AS IS" AND WITH ALL FAULTS, AND DISCLAIMS ALL WARRANTIES, EXPRESS AND IMPLIED, INCLUDING WITHOUT LIMITATION ANY IMPLIED WARRANTIES OF MERCHANTABILITY, FITNESS FOR A PARTICULAR PURPOSE OR NON-INFRINGEMENT OF THIRD PARTY INTELLECTUAL PROPERTY RIGHTS.

These resources are intended for skilled developers designing with TI products. You are solely responsible for (1) selecting the appropriate TI products for your application, (2) designing, validating and testing your application, and (3) ensuring your application meets applicable standards, and any other safety, security, or other requirements. These resources are subject to change without notice. TI grants you permission to use these resources only for development of an application that uses the TI products described in the resource. Other reproduction and display of these resources is prohibited. No license is granted to any other TI intellectual property right or to any third party intellectual property right. TI disclaims responsibility for, and you will fully indemnify TI and its representatives against, any claims, damages, costs, losses, and liabilities arising out of your use of these resources.

TI's products are provided subject to TI's Terms of Sale (www.ti.com/legal/termsofsale.html) or other applicable terms available either on ti.com or provided in conjunction with such TI products. TI's provision of these resources does not expand or otherwise alter TI's applicable warranties or warranty disclaimers for TI products.

Mailing Address: Texas Instruments, Post Office Box 655303, Dallas, Texas 75265
Copyright © 2019, Texas Instruments Incorporated

Looking for pricing, stock, or lifecycle information?

Click below to explore more details on WIN SOURCE:

 [View ADS1602IPFBT on WIN SOURCE](#)

 [Texas Instruments](#) Information

Optimize Your Supply Chain with WIN SOURCE Solutions

-  Global Sourcing Solution
-  Obsolete Management
-  Cost Control Management
-  Shortage Management
-  Alternative Solution
-  Excess Inventory Management