



**THE DATASHEET OF
SN74LV126APWT**



SNx4LV126A Quadruple Bus Buffer Gates With 3-State Outputs

1 Features

- 2-V to 5.5-V V_{CC} Operation
- Max t_{pd} of 6.5 ns at 5 V
- Typical V_{OLP} (Output Ground Bounce) <0.8 V at $V_{CC} = 3.3$ V, $T_A = 25^\circ\text{C}$
- Typical V_{OHV} (Output V_{OH} Undershoot) >2.3 V at $V_{CC} = 3.3$ V, $T_A = 25^\circ\text{C}$
- Ioff Supports Live Insertion, Partial Power Down Mode, and Back Drive Protection
- Support Mixed-Mode Voltage Operation on All Ports
- Latch-Up Performance Exceeds 250 mA per JESD 17
- ESD Protection Exceeds JESD 22
 - 2000-V Human-Body Model (A114-A)
 - 200-V Machine Model (A115-A)
 - 1000-V Charged-Device Model (C101)

2 Applications

- Servers
- Network Switch
- Electronic Point of Sales
- TV
- Set-Top-Box

3 Description

The 'LV126A quadruple bus buffer gates are designed for 2-V to 5.5-V V_{CC} operation.

These quadruple bus buffer gates are designed for 2-V to 5.5-V V_{CC} operation.

The 'LV126A devices feature independent line drivers with 3-state outputs. Each output is disabled when the associated output-enable (OE) input is low.

To ensure the high-impedance state during power up or power down, OE should be tied to GND through a pulldown resistor; the minimum value of the resistor is determined by the current-sourcing capability of the driver.

Device Information⁽¹⁾

PART NUMBER	PACKAGE	BODY SIZE (NOM)
SN74LV126A	SOIC (14)	3.91 mm × 8.65 mm
	SOP (14)	5.30 mm × 10.30 mm
	SSOP (14)	5.30 mm × 6.20 mm
	TSSOP (14)	4.40 mm × 5.00 mm
	TVSOP (14)	4.40 mm × 3.60 mm

(1) For all available packages, see the orderable addendum at the end of the data sheet.

Logic Diagram (Positive Logic)

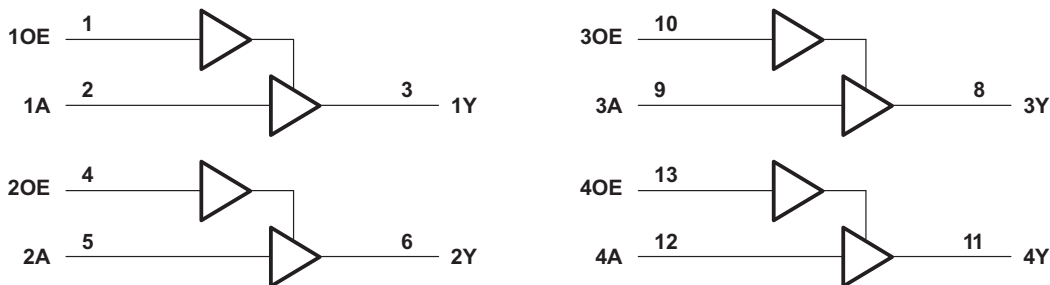

Table of Contents

1 Features	1	8 Detailed Description	9
2 Applications	1	8.1 Overview	9
3 Description	1	8.2 Functional Block Diagram	9
4 Revision History	2	8.3 Feature Description	9
5 Pin Configuration and Functions	3	8.4 Device Functional Modes	9
6 Specifications	4	9 Application and Implementation	10
6.1 Absolute Maximum Ratings	4	9.1 Application Information	10
6.2 ESD Ratings	4	9.2 Typical Application	10
6.3 Recommended Operating Conditions	4	10 Power Supply Recommendations	11
6.4 Thermal Information	5	11 Layout	11
6.5 Electrical Characteristics	5	11.1 Layout Guidelines	11
6.6 Switching Characteristics, $V_{CC} = 2.5\text{ V} \pm 0.2\text{ V}$	6	11.2 Layout Example	11
6.7 Switching Characteristics, $V_{CC} = 3.3\text{ V} \pm 0.3\text{ V}$	6	12 Device and Documentation Support	12
6.8 Switching Characteristics, $V_{CC} = 5\text{ V} \pm 0.5\text{ V}$	6	12.1 Related Links	12
6.9 Noise Characteristics for SN74LV126A	7	12.2 Trademarks	12
6.10 Operating Characteristics	7	12.3 Electrostatic Discharge Caution	12
6.11 Typical Characteristics	7	12.4 Glossary	12
7 Parameter Measurement Information	8	13 Mechanical, Packaging, and Orderable Information	12

4 Revision History

Changes from Revision H (April 2005) to Revision I

Page

- Added *ESD Ratings* table, *Feature Description* section, *Device Functional Modes*, *Application and Implementation* section, *Power Supply Recommendations* section, *Layout* section, *Device and Documentation Support* section, and *Mechanical, Packaging, and Orderable Information* section
- Updated operating free-air temperature maximum from 85°C to 125°C for SN74LV126A

5 Pin Configuration and Functions

SN54LV126A: J or W Package
SN74LV126A: D, DB, DGV, NS, or PW Package
(Top View)

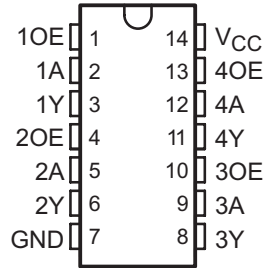

SN54LV126A: FK Package
(Top View)

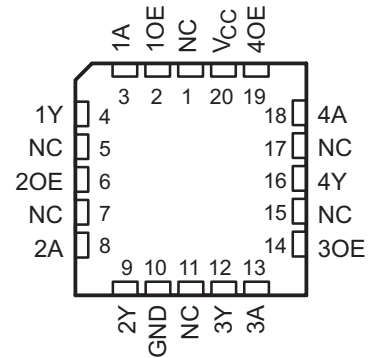

A. NC – No internal connection

Pin Functions

PIN	I/O	DESCRIPTION
1	1OE	Enable pin
2	1A	Input 1
3	1Y	Output 1
4	2OE	Enable 2
5	2A	Input 2
6	2Y	Output 2
7	GND	GND
8	3Y	Output 3
9	3A	Input 3
10	3OE	Enable 3
11	4Y	Output 4
12	4A	Input 4
13	4OE	Enable 4
14	V _{CC}	V _{CC}

6 Specifications

6.1 Absolute Maximum Ratings

 over operating free-air temperature range (unless otherwise noted) ⁽¹⁾

		MIN	MAX	UNIT
V _{CC}	Supply voltage	-0.5	7	V
V _I	Input voltage ⁽²⁾	-0.5	7	V
V _O	Voltage applied to any output in the high-impedance or power-off state ⁽²⁾	-0.5	7	V
V _O	Output voltage ⁽²⁾⁽³⁾	-0.5	V _{CC} + 0.5 V	V
I _{IK}	Input clamp current, V _I < 0		-20	mA
I _{OK}	Output clamp current, V _O < 0		-50	mA
I _O	Continuous output current, V _O = 0 to V _{CC}	-35	35	mA
	Continuous current through V _{CC} or GND	-70	70	mA
T _{stg}	Storage temperature	-65	150	°C

(1) Stresses beyond those listed under *Absolute Maximum Ratings* may cause permanent damage to the device. These are stress ratings only, which do not imply functional operation of the device at these or any other conditions beyond those indicated under *Recommended Operating Conditions*. Exposure to absolute-maximum-rated conditions for extended periods may affect device reliability.

(2) The input and output negative-voltage ratings may be exceeded if the input and output current ratings are observed.

(3) This value is limited to 5.5-V maximum.

6.2 ESD Ratings

		VALUE	UNIT
V _(ESD)	Electrostatic discharge	Human-body model (HBM), per ANSI/ESDA/JEDEC JS-001 ⁽¹⁾	2000
		Charged-device model (CDM), per JEDEC specification JESD22-C101 ⁽²⁾	1000

(1) JEDEC document JEP155 states that 500-V HBM allows safe manufacturing with a standard ESD control process.

(2) JEDEC document JEP157 states that 250-V CDM allows safe manufacturing with a standard ESD control process.

6.3 Recommended Operating Conditions

 see ⁽¹⁾

		MIN	MAX	UNIT
V _{CC}	Supply voltage	2	5.5	V
V _{IH}	High-level input voltage	V _{CC} = 2 V	1.5	V
		V _{CC} = 2.3 to 2.7 V	V _{CC} × 0.7	
		V _{CC} = 3 to 3.6 V	V _{CC} × 0.7	
		V _{CC} = 4.5 to 5.5 V	V _{CC} × 0.7	
V _{IL}	Low-level input voltage	V _{CC} = 2 V	0.5	V
		V _{CC} = 2.3 to 2.7 V	V _{CC} × 0.3	
		V _{CC} = 3 to 3.6 V	V _{CC} × 0.3	
		V _{CC} = 4.5 to 5.5 V	V _{CC} × 0.3	
V _I	Input voltage	0	5.5	V
V _O	Output voltage	High or low state	0	V _{CC}
		3-state	0	5.5
I _{OH}	High-level output current	V _{CC} = 2 V	-50	μA
		V _{CC} = 2.3 to 2.7 V	-2	mA
		V _{CC} = 3 to 3.6 V	-8	
		V _{CC} = 4.5 to 5.5 V	-16	

(1) All unused inputs of the device must be held at V_{CC} or GND to ensure proper device operation. Refer to the TI application report, *Implications of Slow or Floating CMOS Inputs*, SCBA004.

Recommended Operating Conditions (continued)

 see ⁽¹⁾

		MIN	MAX	UNIT	
I_{OL}	Low-level output current	$V_{CC} = 2\text{ V}$	50	μA	
		$V_{CC} = 2.3\text{ to }2.7\text{ V}$	2	mA	
		$V_{CC} = 3\text{ to }3.6\text{ V}$	8		
		$V_{CC} = 4.5\text{ to }5.5\text{ V}$	16		
$\Delta t/\Delta v$	Input transition rise or fall rate	$V_{CC} = 2.3\text{ to }2.7\text{ V}$	200	ns/V	
		$V_{CC} = 3\text{ to }3.6\text{ V}$	100		
		$V_{CC} = 4.5\text{ to }5.5\text{ V}$	20		
T_A	Operating free-air temperature	SN54LV126A	–55	125	$^{\circ}\text{C}$
		SN74LV126A	–40	125	

6.4 Thermal Information

THERMAL METRIC ⁽¹⁾	D	DB	DGV	NS	PW	UNIT	
	14 PINS						
$R_{\theta JA}$	Junction-to-ambient thermal resistance ⁽²⁾	92.7	105.0	127.6	89.6	119.8	$^{\circ}\text{C}/\text{W}$
$R_{\theta JC(\text{top})}$	Junction-to-case (top) thermal resistance	54.1	57.5	50.7	47.2	48.6	
$R_{\theta JB}$	Junction-to-board thermal resistance	47.0	52.3	60.5	48.4	61.5	
Ψ_{JT}	Junction-to-top characterization parameter	18.9	19.1	6.1	14.0	5.7	
Ψ_{JB}	Junction-to-board characterization parameter	46.7	51.8	59.8	48.1	61.0	

(1) For more information about traditional and new thermal metrics, see the *IC Package Thermal Metrics* application report, [SPRA953](#).

(2) The package thermal impedance is calculated in accordance with JESD 51-7.

6.5 Electrical Characteristics

over recommended operating free-air temperature range (unless otherwise noted)

PARAMETER	TEST CONDITIONS	V_{CC}	MIN	TYP	MAX	UNIT
V_{OH}	$I_{OH} = -50\ \mu\text{A}$	2 to 5.5 V	$V_{CC} - 0.1$		V	
	$I_{OH} = -2\ \text{mA}$	2.3 V	2			
	$I_{OH} = -8\ \text{mA}$	3 V	2.48			
	$I_{OH} = -16\ \text{mA}$	4.5 V	3.8			
V_{OL}	$I_{OL} = 50\ \mu\text{A}$	2 to 5.5 V	0.1		V	
	$I_{OL} = 2\ \text{mA}$	2.3 V	0.4			
	$I_{OL} = 8\ \text{mA}$	3 V	0.44			
	$I_{OL} = 16\ \text{mA}$	4.5 V	0.55			
I_I	$V_I = 5.5\ \text{V}$ or GND	0 to 5.5 V	± 1		μA	
I_{OZ}	$V_O = V_{CC}$ or GND	5.5 V	± 5		μA	
I_{CC}	$V_I = V_{CC}$ or GND, $I_O = 0$	5.5 V	20		μA	
I_{off}	V_I or $V_O = 0$ to 5.5 V	0	5		μA	
C_i	$V_I = V_{CC}$ or GND	3.3 V	1.6		pF	

6.6 Switching Characteristics, $V_{CC} = 2.5\text{ V} \pm 0.2\text{ V}$

 over recommended operating free-air temperature range (unless otherwise noted) (see [Figure 3](#))

PARAMETER	FROM (INPUT)	TO (OUTPUT)	LOAD CAPACITANCE	$T_A = 25^\circ\text{C}$			MIN	MAX	UNIT
				MIN	TYP	MAX			
t_{pd}	A	Y	$C_L = 15\text{ pF}$	7.1 ⁽¹⁾	13 ⁽¹⁾	1 ⁽²⁾	15.5 ⁽²⁾	ns	
t_{en}	OE			7.4 ⁽¹⁾	13 ⁽¹⁾	1 ⁽²⁾	15.5 ⁽²⁾		
t_{dis}	OE			5.7 ⁽¹⁾	14.7 ⁽¹⁾	1 ⁽²⁾	17 ⁽²⁾		
t_{pd}	A	Y	$C_L = 50\text{ pF}$	9.2	16.5	1	18.5	ns	
t_{en}	OE			9.5	16.5	1	18.5		
t_{dis}	OE			8.1	18.2	15	20.5		
$t_{sk(o)}$					2		2 ⁽³⁾		

(1) On products compliant to MIL-PRF-38535, this parameter is not production tested.

(2) This note applies to SN54LV126A only: On products compliant to MIL-PRF-38535, this parameter is not production tested.

(3) Value applies for SN74LV126A only

6.7 Switching Characteristics, $V_{CC} = 3.3\text{ V} \pm 0.3\text{ V}$

 over recommended operating free-air temperature range (unless otherwise noted) (see [Figure 3](#))

PARAMETER	FROM (INPUT)	TO (OUTPUT)	LOAD CAPACITANCE	$T_A = 25^\circ\text{C}$			MIN	MAX	UNIT
				MIN	TYP	MAX			
t_{pd}	A	Y	$C_L = 15\text{ pF}$	5 ⁽¹⁾	8 ⁽¹⁾	1 ⁽²⁾	9.5 ⁽²⁾	ns	
t_{en}	OE			5.1 ⁽¹⁾	8 ⁽¹⁾	1 ⁽²⁾	9.5 ⁽²⁾		
t_{dis}	OE			4.4 ⁽¹⁾	9.7 ⁽¹⁾	1 ⁽²⁾	11.5 ⁽²⁾		
t_{pd}	A	Y	$C_L = 50\text{ pF}$	6.4	11.5	1	13	ns	
t_{en}	OE			6.6	11.5	1	13		
t_{dis}	OE			6.1	13.2	1	15		
$t_{sk(o)}$					1.5		1.5 ⁽³⁾		

(1) On products compliant to MIL-PRF-38535, this parameter is not production tested.

(2) This note applies to SN54LV126A only: On products compliant to MIL-PRF-38535, this parameter is not production tested.

(3) Value applies for SN74LV126A only

6.8 Switching Characteristics, $V_{CC} = 5\text{ V} \pm 0.5\text{ V}$

 over recommended operating free-air temperature range (unless otherwise noted) (see [Figure 3](#))

PARAMETER	FROM (INPUT)	TO (OUTPUT)	LOAD CAPACITANCE	$T_A = 25^\circ\text{C}$			MIN	MAX	UNIT
				MIN	TYP	MAX			
t_{pd}	A	Y	$C_L = 15\text{ pF}$	3.5 ⁽¹⁾	5.5 ⁽¹⁾	1 ⁽²⁾	6.5 ⁽²⁾	ns	
t_{en}	OE			3.6 ⁽¹⁾	5.1 ⁽¹⁾	1 ⁽²⁾	6 ⁽²⁾		
t_{dis}	OE			3.3 ⁽¹⁾	6.8 ⁽¹⁾	1 ⁽²⁾	8 ⁽²⁾		
t_{pd}	A	Y	$C_L = 50\text{ pF}$	4.6	7.5	1	8.5	ns	
t_{en}	OE			4.6	7.1	1	8		
t_{dis}	OE			4.3	8.8	1	10		
$t_{sk(o)}$					1		1 ⁽³⁾		

(1) On products compliant to MIL-PRF-38535, this parameter is not production tested.

(2) This note applies to SN54LV126A only: On products compliant to MIL-PRF-38535, this parameter is not production tested.

(3) This values applies for SN74LV126A only

6.9 Noise Characteristics for SN74LV126A

$V_{CC} = 3.3\text{ V}$, $C_L = 50\text{ pF}$, $T_A = 25^\circ\text{C}$ (see ⁽¹⁾)

PARAMETER		MIN	TYP	MAX	UNIT
$V_{OL(P)}$	Quiet output, maximum dynamic V_{OL}		0.3	0.8	V
$V_{OL(V)}$	Quiet output, minimum dynamic V_{OL}		-0.2	-0.8	
$V_{OH(V)}$	Quiet output, minimum dynamic V_{OH}		3.1		
$V_{IH(D)}$	High-level dynamic input voltage	2.31			
$V_{IL(D)}$	Low-level dynamic input voltage			0.97	

(1) Characteristics are for surface-mount packages only.

6.10 Operating Characteristics

$T_A = 25^\circ\text{C}$

PARAMETER	TEST CONDITIONS	V_{CC}	TYP	UNIT	
C_{pd}	Power dissipation capacitance	Outputs enable; $C_L = 50\text{ pF}$, $f = 10\text{ MHz}$	3.3 V	14.4	pF
			5 V	15.9	

6.11 Typical Characteristics

TBD

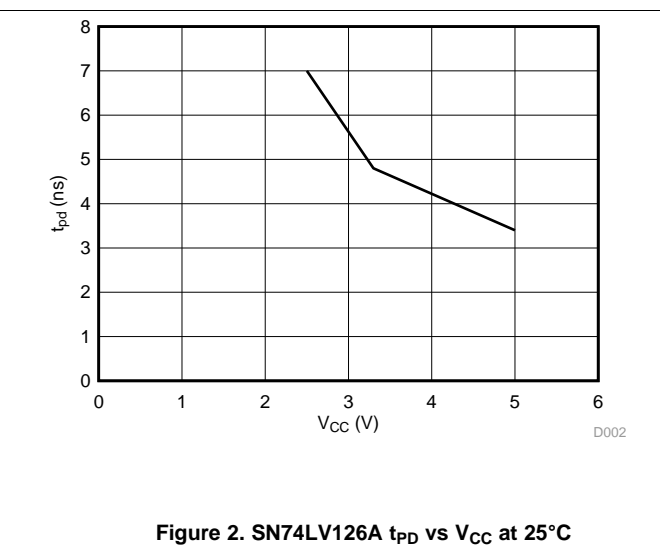
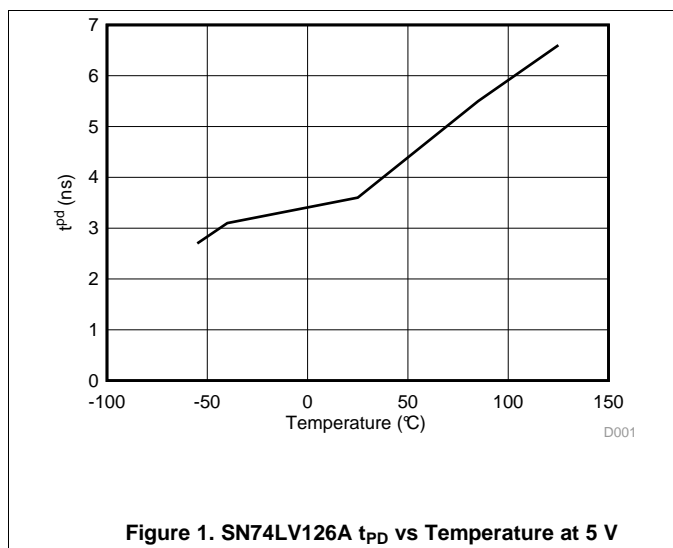

7 Parameter Measurement Information

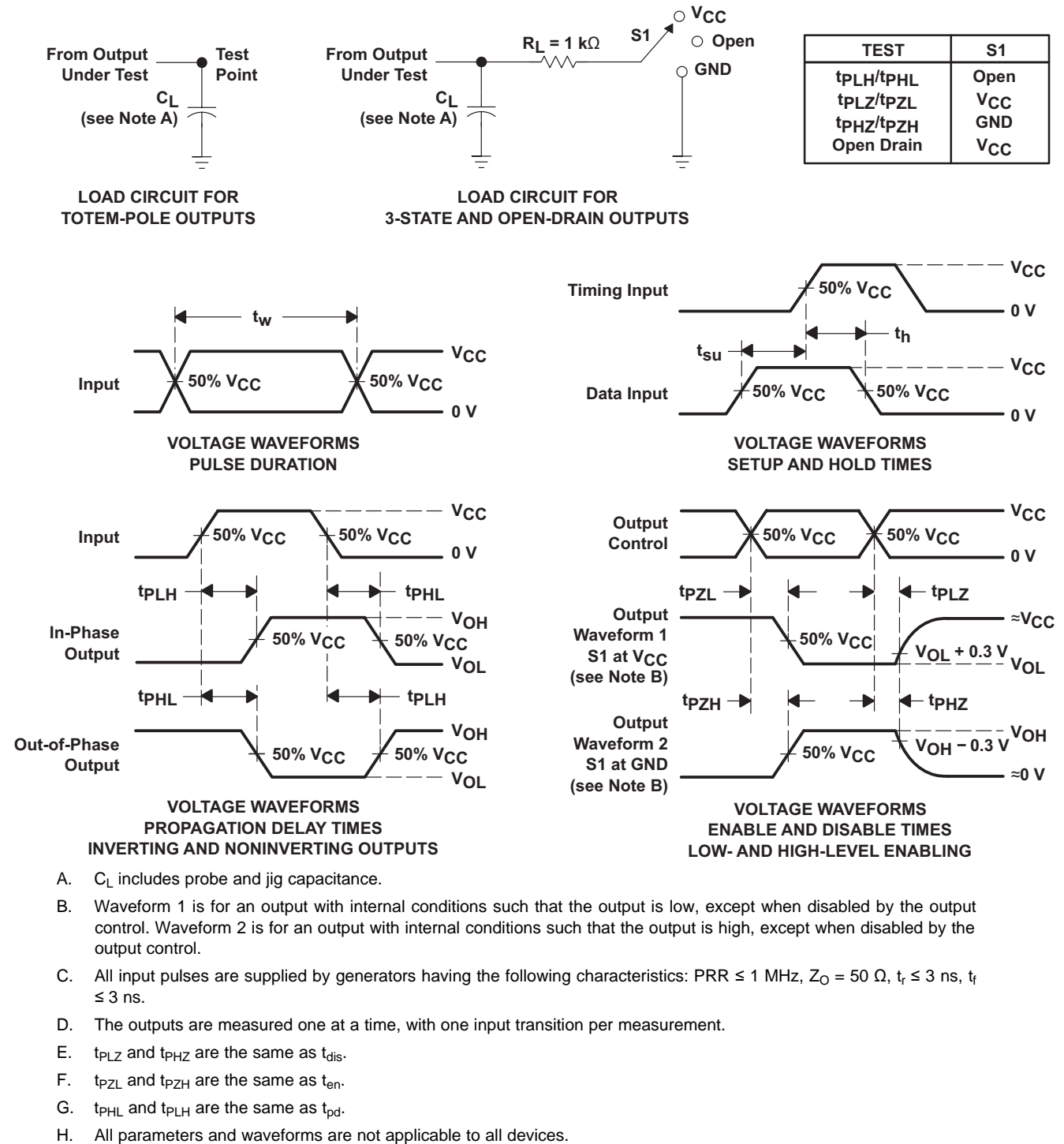

Figure 3. Load Circuit and Voltage Waveforms

8 Detailed Description

8.1 Overview

The SN74LV126A devices are quadruple bus buffer gates featuring independent line drivers with 3-state outputs. Each output is disabled when the associated output-enable (OE) input is low. When OE is high, the respective gate passes the data from the A input to its Y output. To ensure the high-impedance state during power up or power down, OE should be tied to GND through a pulldown resistor; the minimum value of the resistor is determined by the current-sourcing capability of the driver.

8.2 Functional Block Diagram

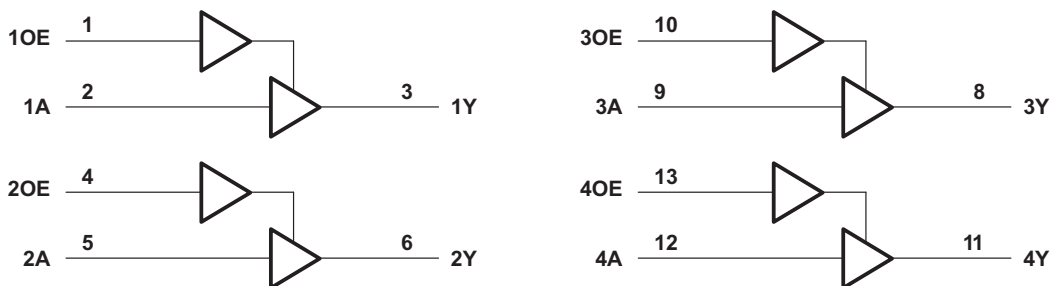

A. Pin numbers shown are for the D, DB, DGV, J, N, NS, PW, and W packages.

Figure 4. Logic Diagram (Positive Logic)

8.3 Feature Description

- Wide operating voltage range, operates from 2 to 5.5 V
- Allows down voltage translation, inputs accept voltages to 5.5 V
- Ioff supports live insertion, partial power down mode, and back drive protection

8.4 Device Functional Modes

Table 1. Function Table (Each Buffer)

INPUTS		OUTPUT Y
$\overline{\text{OE}}$	A	
L	H	H
L	L	L
H	X	Z

9 Application and Implementation

NOTE

Information in the following applications sections is not part of the TI component specification, and TI does not warrant its accuracy or completeness. TI's customers are responsible for determining suitability of components for their purposes. Customers should validate and test their design implementation to confirm system functionality.

9.1 Application Information

The SN74LV126A is a low-drive CMOS device that can be used for a multitude of bus interface type applications where output ringing is a concern. The low drive and slow edge rates minimize overshoot and undershoot on the outputs. The inputs are 5.5-V tolerant at any valid V_{CC} making Ideal for translating down to V_{CC} .

9.2 Typical Application

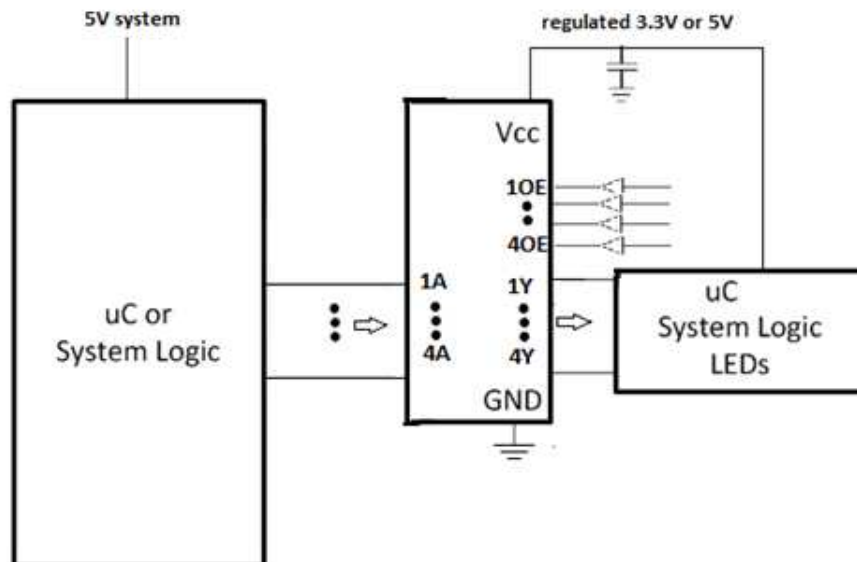

Figure 5. Typical Application Schematic

9.2.1 Design Requirements

This device uses CMOS technology and has balanced output drive. Care should be taken to avoid bus contention because it can drive currents that would exceed maximum limits. The high drive will also create fast edges into light loads so routing and load conditions should be considered to prevent ringing.

9.2.2 Detailed Design Procedure

1. Recommended input conditions
 - Rise time and fall time specs see $(\Delta t/\Delta V)$ in [Recommended Operating Conditions](#).
 - Specified High and low levels. See $(V_{IH}$ and $V_{IL})$ in [Recommended Operating Conditions](#).
2. Recommend output conditions
 - Load currents should not exceed 35 mA per output and 70 mA total for the part
 - Outputs should not be pulled above V_{CC}

Typical Application (continued)

9.2.3 Application Curve

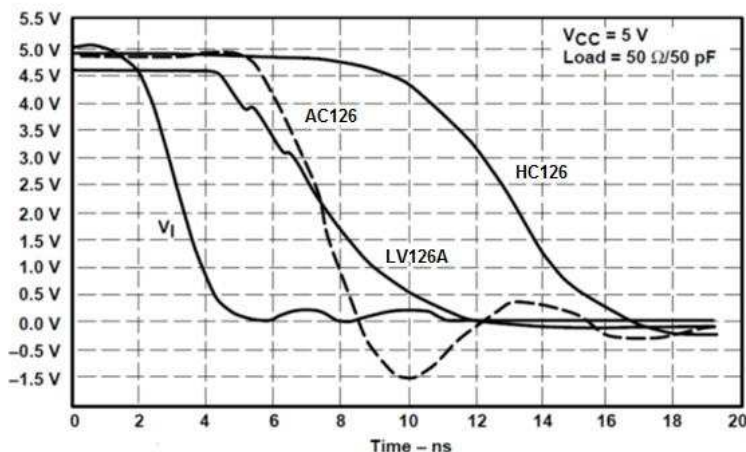

Figure 6. Switching Characteristics Comparison

10 Power Supply Recommendations

The power supply can be any voltage between the Min and Max supply voltage rating located in [Recommended Operating Conditions](#). Each V_{CC} terminal should have a good bypass capacitor to prevent power disturbance. For devices with a single supply, 0.1 μF is recommended and if there are multiple V_{CC} terminals then .01 or .022 μF is recommended for each power terminal. It is ok to parallel multiple bypass capacitors to reject different frequencies of noise. A 0.1 and 1 μF are commonly used in parallel. The bypass capacitor should be installed as close to the power terminal as possible for best results.

11 Layout

11.1 Layout Guidelines

When using multiple bit logic devices inputs should not ever float. In many cases, functions or parts of functions of digital logic devices are unused, for example, when only two inputs of a triple-input AND gate are used or only 3 of the 4 buffer gates are used. Such input pins should not be left unconnected because the undefined voltages at the outside connections result in undefined operational states. Specified below are the rules that must be observed under all circumstances. All unused inputs of digital logic devices must be connected to a high or low bias to prevent them from floating. The logic level that should be applied to any particular unused input depends on the function of the device. Generally they will be tied to GND or V_{CC} whichever make more sense or is more convenient. It is generally okay to float outputs unless the part is a transceiver. If the transceiver has an output enable pin it will disable the outputs section of the part when asserted. This will not disable the input section of the IOs so they also cannot float when disabled.

11.2 Layout Example

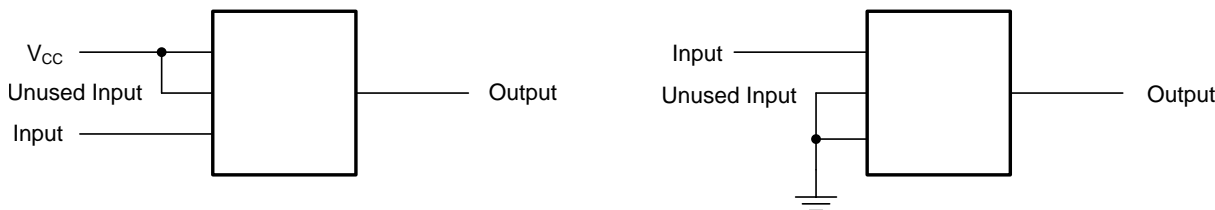

Figure 7. Layout Recommendation

12 Device and Documentation Support

12.1 Related Links

The table below lists quick access links. Categories include technical documents, support and community resources, tools and software, and quick access to sample or buy.

Table 2. Related Links

PARTS	PRODUCT FOLDER	SAMPLE & BUY	TECHNICAL DOCUMENTS	TOOLS & SOFTWARE	SUPPORT & COMMUNITY
SN54LV126A	Click here	Click here	Click here	Click here	Click here
SN74LV126A	Click here	Click here	Click here	Click here	Click here

12.2 Trademarks

All trademarks are the property of their respective owners.

12.3 Electrostatic Discharge Caution



These devices have limited built-in ESD protection. The leads should be shorted together or the device placed in conductive foam during storage or handling to prevent electrostatic damage to the MOS gates.

12.4 Glossary

[SLYZ022](#) — *TI Glossary*.

This glossary lists and explains terms, acronyms, and definitions.

13 Mechanical, Packaging, and Orderable Information

The following pages include mechanical, packaging, and orderable information. This information is the most current data available for the designated devices. This data is subject to change without notice and revision of this document. For browser-based versions of this data sheet, refer to the left-hand navigation.

PACKAGING INFORMATION

Orderable Device	Status (1)	Package Type	Package Drawing	Pins	Package Qty	Eco Plan (2)	Lead/Ball Finish (6)	MSL Peak Temp (3)	Op Temp (°C)	Device Marking (4/5)	Samples
SN74LV126AD	ACTIVE	SOIC	D	14	50	Green (RoHS & no Sb/Br)	CU NIPDAU	Level-1-260C-UNLIM	-40 to 125	LV126A	Samples
SN74LV126ADBR	ACTIVE	SSOP	DB	14	2000	Green (RoHS & no Sb/Br)	CU NIPDAU	Level-1-260C-UNLIM	-40 to 125	LV126A	Samples
SN74LV126ADGVR	ACTIVE	TVSOP	DGV	14	2000	Green (RoHS & no Sb/Br)	CU NIPDAU	Level-1-260C-UNLIM	-40 to 125	LV126A	Samples
SN74LV126ADR	ACTIVE	SOIC	D	14	2500	Green (RoHS & no Sb/Br)	CU NIPDAU	Level-1-260C-UNLIM	-40 to 125	LV126A	Samples
SN74LV126ANSR	ACTIVE	SO	NS	14	2000	Green (RoHS & no Sb/Br)	CU NIPDAU	Level-1-260C-UNLIM	-40 to 125	74LV126A	Samples
SN74LV126APW	ACTIVE	TSSOP	PW	14	90	Green (RoHS & no Sb/Br)	CU NIPDAU	Level-1-260C-UNLIM	-40 to 125	LV126A	Samples
SN74LV126APWR	ACTIVE	TSSOP	PW	14	2000	Green (RoHS & no Sb/Br)	CU NIPDAU	Level-1-260C-UNLIM	-40 to 125	LV126A	Samples
SN74LV126APWRG4	ACTIVE	TSSOP	PW	14	2000	Green (RoHS & no Sb/Br)	CU NIPDAU	Level-1-260C-UNLIM	-40 to 125	LV126A	Samples
SN74LV126APWT	ACTIVE	TSSOP	PW	14	250	Green (RoHS & no Sb/Br)	CU NIPDAU	Level-1-260C-UNLIM	-40 to 125	LV126A	Samples

(1) The marketing status values are defined as follows:

ACTIVE: Product device recommended for new designs.

LIFEBUY: TI has announced that the device will be discontinued, and a lifetime-buy period is in effect.

NRND: Not recommended for new designs. Device is in production to support existing customers, but TI does not recommend using this part in a new design.

PREVIEW: Device has been announced but is not in production. Samples may or may not be available.

OBSOLETE: TI has discontinued the production of the device.

(2) **RoHS:** TI defines "RoHS" to mean semiconductor products that are compliant with the current EU RoHS requirements for all 10 RoHS substances, including the requirement that RoHS substance do not exceed 0.1% by weight in homogeneous materials. Where designed to be soldered at high temperatures, "RoHS" products are suitable for use in specified lead-free processes. TI may reference these types of products as "Pb-Free".

RoHS Exempt: TI defines "RoHS Exempt" to mean products that contain lead but are compliant with EU RoHS pursuant to a specific EU RoHS exemption.

Green: TI defines "Green" to mean the content of Chlorine (Cl) and Bromine (Br) based flame retardants meet JS709B low halogen requirements of <=1000ppm threshold. Antimony trioxide based flame retardants must also meet the <=1000ppm threshold requirement.

(3) MSL, Peak Temp. - The Moisture Sensitivity Level rating according to the JEDEC industry standard classifications, and peak solder temperature.

(4) There may be additional marking, which relates to the logo, the lot trace code information, or the environmental category on the device.

(5) Multiple Device Markings will be inside parentheses. Only one Device Marking contained in parentheses and separated by a "~" will appear on a device. If a line is indented then it is a continuation of the previous line and the two combined represent the entire Device Marking for that device.

(6) Lead/Ball Finish - Orderable Devices may have multiple material finish options. Finish options are separated by a vertical ruled line. Lead/Ball Finish values may wrap to two lines if the finish value exceeds the maximum column width.

Important Information and Disclaimer:The information provided on this page represents TI's knowledge and belief as of the date that it is provided. TI bases its knowledge and belief on information provided by third parties, and makes no representation or warranty as to the accuracy of such information. Efforts are underway to better integrate information from third parties. TI has taken and continues to take reasonable steps to provide representative and accurate information but may not have conducted destructive testing or chemical analysis on incoming materials and chemicals. TI and TI suppliers consider certain information to be proprietary, and thus CAS numbers and other limited information may not be available for release.

In no event shall TI's liability arising out of such information exceed the total purchase price of the TI part(s) at issue in this document sold by TI to Customer on an annual basis.

TAPE AND REEL INFORMATION

QUADRANT ASSIGNMENTS FOR PIN 1 ORIENTATION IN TAPE

*All dimensions are nominal

Device	Package Type	Package Drawing	Pins	SPQ	Reel Diameter (mm)	Reel Width W1 (mm)	A0 (mm)	B0 (mm)	K0 (mm)	P1 (mm)	W (mm)	Pin1 Quadrant
SN74LV126ADGVR	TVSOP	DGV	14	2000	330.0	12.4	6.8	4.0	1.6	8.0	12.0	Q1
SN74LV126ADR	SOIC	D	14	2500	330.0	16.4	6.5	9.0	2.1	8.0	16.0	Q1
SN74LV126ANSR	SO	NS	14	2000	330.0	16.4	8.2	10.5	2.5	12.0	16.0	Q1
SN74LV126APWR	TSSOP	PW	14	2000	330.0	12.4	6.9	5.6	1.6	8.0	12.0	Q1
SN74LV126APWT	TSSOP	PW	14	250	330.0	12.4	6.9	5.6	1.6	8.0	12.0	Q1

TAPE AND REEL BOX DIMENSIONS

*All dimensions are nominal

Device	Package Type	Package Drawing	Pins	SPQ	Length (mm)	Width (mm)	Height (mm)
SN74LV126ADGVR	TVSOP	DGV	14	2000	367.0	367.0	35.0
SN74LV126ADR	SOIC	D	14	2500	367.0	367.0	38.0
SN74LV126ANSR	SO	NS	14	2000	367.0	367.0	38.0
SN74LV126APWR	TSSOP	PW	14	2000	367.0	367.0	35.0
SN74LV126APWT	TSSOP	PW	14	250	367.0	367.0	35.0

MECHANICAL DATA

NS (R-PDSO-G**)

PLASTIC SMALL-OUTLINE PACKAGE

14-PINS SHOWN



- NOTES:
- A. All linear dimensions are in millimeters.
 - B. This drawing is subject to change without notice.
 - C. Body dimensions do not include mold flash or protrusion, not to exceed 0,15.

DGV (R-PDSO-G**)

PLASTIC SMALL-OUTLINE

24 PINS SHOWN





- NOTES: A. All linear dimensions are in millimeters.
 B. This drawing is subject to change without notice.
 C. Body dimensions do not include mold flash or protrusion, not to exceed 0,15 per side.
 D. Falls within JEDEC: 24/48 Pins – MO-153
 14/16/20/56 Pins – MO-194

D (R-PDSO-G14)

PLASTIC SMALL OUTLINE



4040047-5/M 06/11

- NOTES:
- A. All linear dimensions are in inches (millimeters).
 - B. This drawing is subject to change without notice.
 -  Body length does not include mold flash, protrusions, or gate burrs. Mold flash, protrusions, or gate burrs shall not exceed 0.006 (0,15) each side.
 -  Body width does not include interlead flash. Interlead flash shall not exceed 0.017 (0,43) each side.
 - E. Reference JEDEC MS-012 variation AB.

D (R-PDSO-G14)

PLASTIC SMALL OUTLINE



- NOTES:
- All linear dimensions are in millimeters.
 - This drawing is subject to change without notice.
 - Publication IPC-7351 is recommended for alternate designs.
 - Laser cutting apertures with trapezoidal walls and also rounding corners will offer better paste release. Customers should contact their board assembly site for stencil design recommendations. Refer to IPC-7525 for other stencil recommendations.
 - Customers should contact their board fabrication site for solder mask tolerances between and around signal pads.

PW (R-PDSO-G14)

PLASTIC SMALL OUTLINE

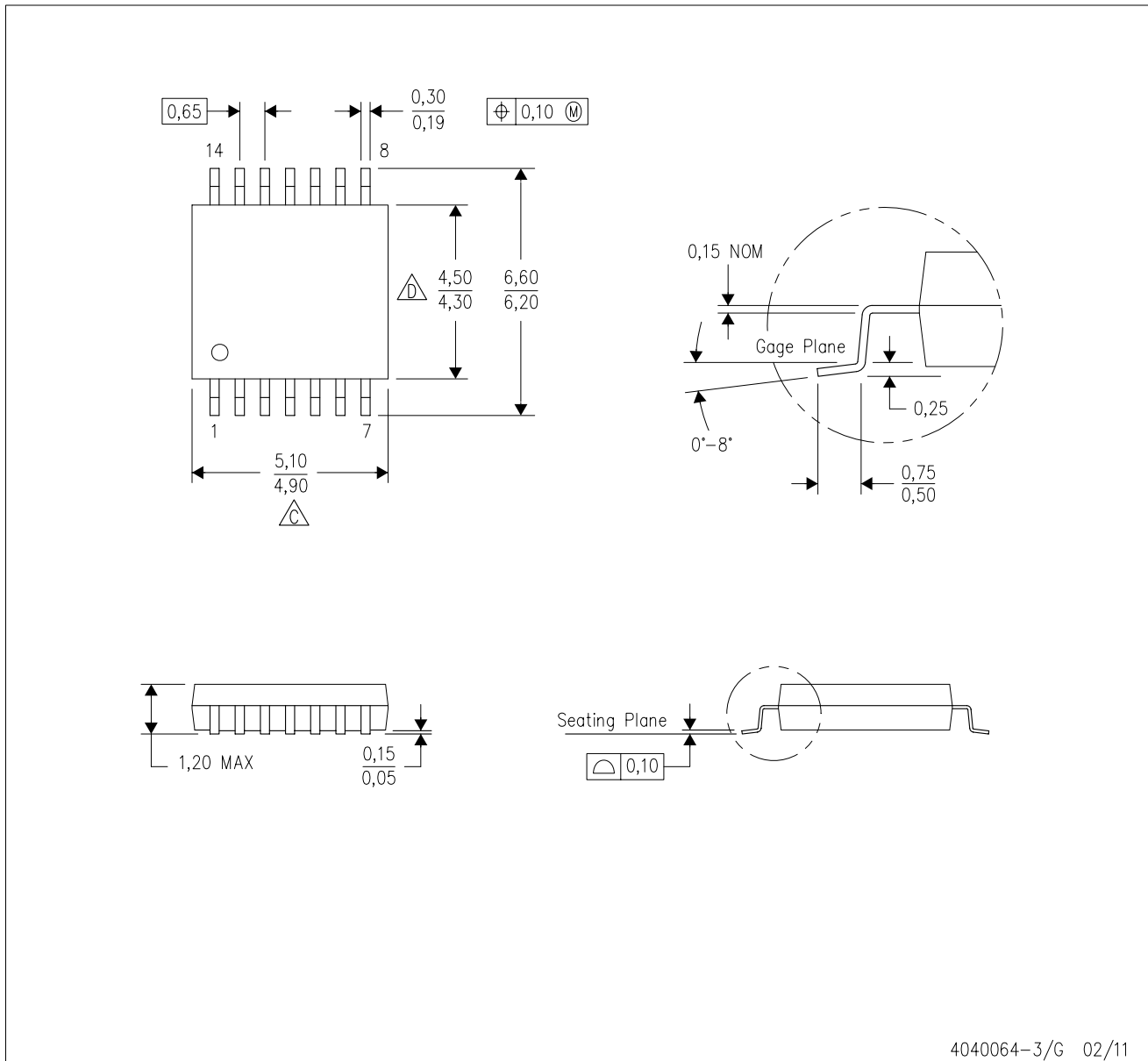

- NOTES:
- A. All linear dimensions are in millimeters. Dimensioning and tolerancing per ASME Y14.5M-1994.
 - B. This drawing is subject to change without notice.
 - C. Body length does not include mold flash, protrusions, or gate burrs. Mold flash, protrusions, or gate burrs shall not exceed 0,15 each side.
 - D. Body width does not include interlead flash. Interlead flash shall not exceed 0,25 each side.
 - E. Falls within JEDEC MO-153

PW (R-PDSO-G14)

PLASTIC SMALL OUTLINE



4211284-2/G 08/15

- NOTES:
- All linear dimensions are in millimeters.
 - This drawing is subject to change without notice.
 - Publication IPC-7351 is recommended for alternate designs.
 - Laser cutting apertures with trapezoidal walls and also rounding corners will offer better paste release. Customers should contact their board assembly site for stencil design recommendations. Refer to IPC-7525 for other stencil recommendations.
 - Customers should contact their board fabrication site for solder mask tolerances between and around signal pads.

DB (R-PDSO-G**)

PLASTIC SMALL-OUTLINE

28 PINS SHOWN



- NOTES: A. All linear dimensions are in millimeters.
 B. This drawing is subject to change without notice.
 C. Body dimensions do not include mold flash or protrusion not to exceed 0,15.
 D. Falls within JEDEC MO-150

IMPORTANT NOTICE AND DISCLAIMER

TI PROVIDES TECHNICAL AND RELIABILITY DATA (INCLUDING DATASHEETS), DESIGN RESOURCES (INCLUDING REFERENCE DESIGNS), APPLICATION OR OTHER DESIGN ADVICE, WEB TOOLS, SAFETY INFORMATION, AND OTHER RESOURCES "AS IS" AND WITH ALL FAULTS, AND DISCLAIMS ALL WARRANTIES, EXPRESS AND IMPLIED, INCLUDING WITHOUT LIMITATION ANY IMPLIED WARRANTIES OF MERCHANTABILITY, FITNESS FOR A PARTICULAR PURPOSE OR NON-INFRINGEMENT OF THIRD PARTY INTELLECTUAL PROPERTY RIGHTS.

These resources are intended for skilled developers designing with TI products. You are solely responsible for (1) selecting the appropriate TI products for your application, (2) designing, validating and testing your application, and (3) ensuring your application meets applicable standards, and any other safety, security, or other requirements. These resources are subject to change without notice. TI grants you permission to use these resources only for development of an application that uses the TI products described in the resource. Other reproduction and display of these resources is prohibited. No license is granted to any other TI intellectual property right or to any third party intellectual property right. TI disclaims responsibility for, and you will fully indemnify TI and its representatives against, any claims, damages, costs, losses, and liabilities arising out of your use of these resources.

TI's products are provided subject to TI's Terms of Sale (www.ti.com/legal/termsofsale.html) or other applicable terms available either on ti.com or provided in conjunction with such TI products. TI's provision of these resources does not expand or otherwise alter TI's applicable warranties or warranty disclaimers for TI products.

Mailing Address: Texas Instruments, Post Office Box 655303, Dallas, Texas 75265
Copyright © 2019, Texas Instruments Incorporated

Looking for pricing, stock, or lifecycle information?

Click below to explore more details on WIN SOURCE:

 [View SN74LV126APWT on WIN SOURCE](#)

 [Texas Instruments](#) Information

Optimize Your Supply Chain with WIN SOURCE Solutions

-  Global Sourcing Solution
-  Obsolete Management
-  Cost Control Management
-  Shortage Management
-  Alternative Solution
-  Excess Inventory Management