



THE DATASHEET OF LP3974RMX/NOPB



LP3974

PRODUCT BRIEF High Performance Power Management Unit for Application Processors

Check for Samples: [LP3974](#)

FEATURES

- **Linear Charger with Single Input**
 - USB or AC Adapter Input
 - 28V OVP on the Charger Input
- **Four High-Efficiency Synchronous Magnetic Buck Regulators:**
 - 2 x 1A, 2 x 800 mA
 - 2 Regulators Have DVS Support
 - High-Efficiency ECO Mode @ low I_{OUT}
 - Can Be Used with Inductors as Low as 1µH @ 4MHz Clock
 - Buck1, Buck2 and Buck4 Have Ramp Control to Change Rate of Change of Output
- **11 General-Type Low Noise LDOs**
 - 7 x 300 mA
 - 2 x 450 mA
 - 2 x 150 mA
- **5 Wide-Input Low-Output (WILO) LDOs**
 - 2 x 10 mA
 - 1 x 50 mA
 - 2 x 150 mA
- **All LDOs S/W Configurable**
- **Two Over-Voltage Protected Outputs for USB Transceivers**
- **Real Time Clock with Two Alarms**
- **Back-Up Battery Charger**
- **Momentary Power Loss Detection**
- **Interrupt Request to Reduce S/W Polling**
- **I²C-Compatible Serial Interface**
- **100-Bump 0.4 mm Pitch Micro SMDxt Package**

APPLICATIONS

- **Smartphones**
- **GSM, GPRS, EDGE, CDMA & WCDMA Handsets**

DESCRIPTION

The LP3974 is designed to meet the power management requirements of the latest cellular phones. The LP3974 PMU contains a single-input Li-Ion battery charger, 16 low-dropout voltage regulators (including 5 wide input low-output regulators, 2 over-voltage protected voltage regulators, and 4 buck regulators), dual DPDT analog switches, real time clock, and backup battery charger. Programming is handled via an I²C-compatible high-speed Serial Interface allowing control of program on/off conditions and the output voltages of individual regulators, and to read status information of the PMU. It can charge and maintain a single cell Li-Ion battery operating from an AC adapter or USB power source.

The Li-Ion charger requires few external components and integrates the power FET. Charging is thermally regulated to obtain the most efficient charging rate for a given ambient temperature. Over-Voltage Protection (OVP) circuit at the charger input protects the PMU from input voltages up to +28V, eliminating the need for any external protection circuitry. Buck regulators have an automatic switch to ECO mode at low load conditions providing very good efficiency at low output currents. General-type LDO regulators provide excellent PSRR and ULTRA LOW NOISE, 45 µV typ., ideally suited for supplying voltage to RF section. The real-time clock/calendar provides time interval information as well as two programmable alarms.

To accommodate different processor requirements, the LP3974 PMU can have three different default voltage settings and startup sequences selected by external pin.

Note: This document is not a full datasheet. For more information regarding this product or to order samples please contact your local National Semiconductor sales office or visit <http://www.national.com/support/dir.html>



Please be aware that an important notice concerning availability, standard warranty, and use in critical applications of Texas Instruments semiconductor products and disclaimers thereto appears at the end of this data sheet.

All trademarks are the property of their respective owners.



These devices have limited built-in ESD protection. The leads should be shorted together or the device placed in conductive foam during storage or handling to prevent electrostatic damage to the MOS gates.

TYPICAL APPLICATION DIAGRAM

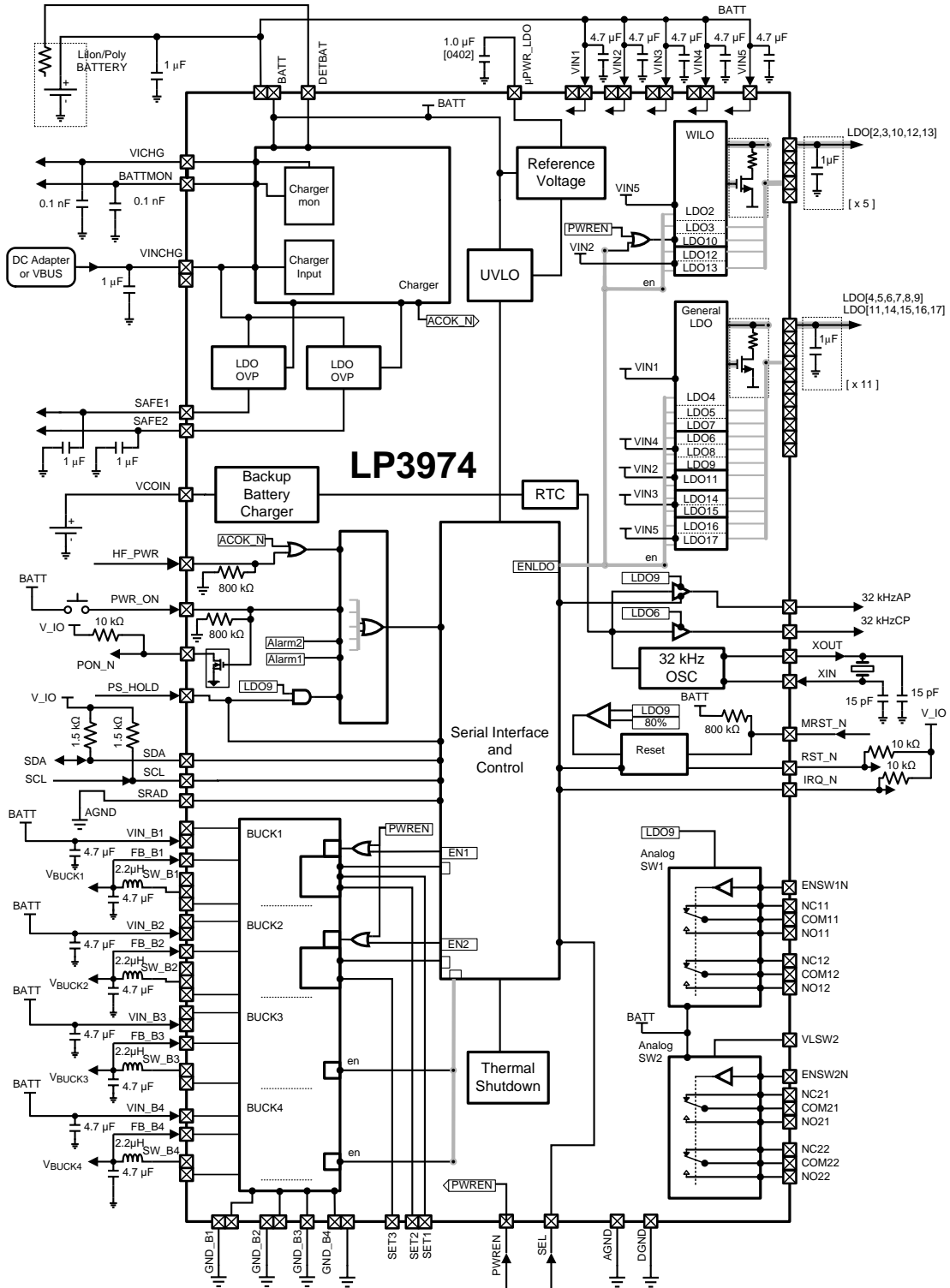

DEVICE PIN DIAGRAM

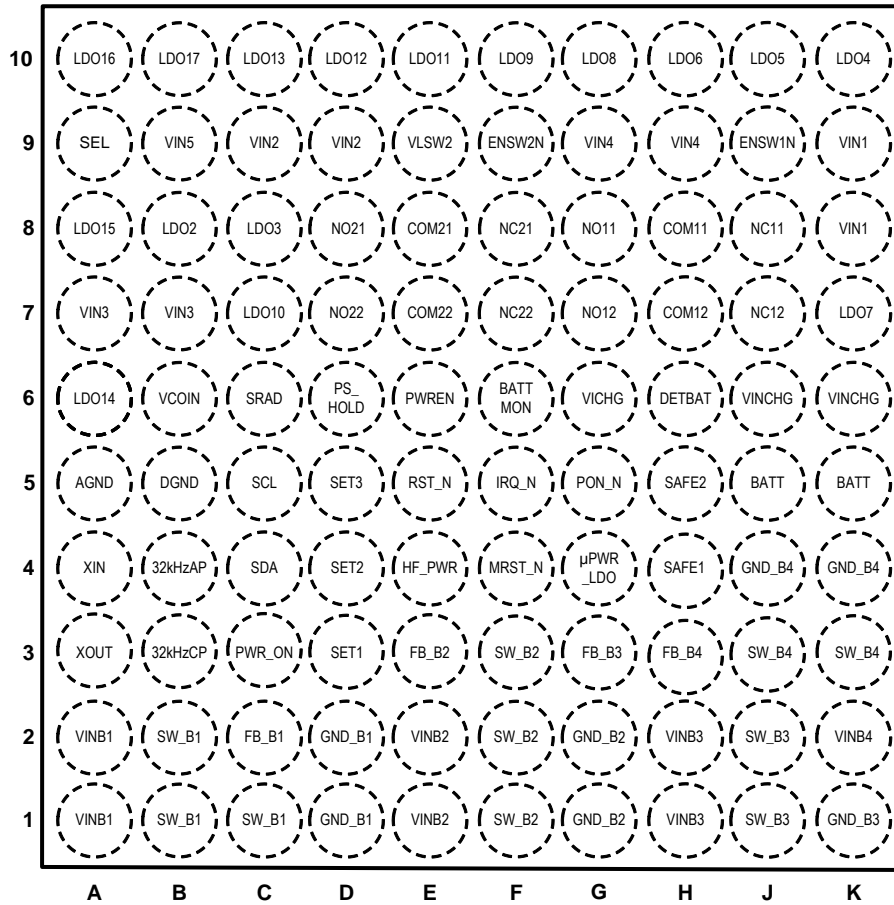

**Figure 1. TOP VIEW
100-Bump (0.4 mm pitch) micro SMDxt Package**

PACKAGE MARKING INFORMATION

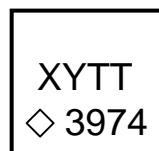

XY = 2-Digit Date Code
 TT = 2-Digit Die Run Trace Code
 LP3974 = Product Identification
 ◇ = Pin A1

Operational Description

The LP3974 is designed for the charging and voltage rail requirements within mobile handsets. The linear charger accepts DC voltages to provide the correct charging and charge maintenance profile for LI-Ion batteries. The charger outputs are programmable to meet the varying needs of these types of batteries. Powered from the Battery input to the device, 4 switching regulators and 16 LDO type linear regulators provide for distributed power within the handset.

APPLICATION INFORMATION

Buck Information

The LP3974 has four integrated high-efficiency step-down DC-DC switching buck converters that deliver a constant voltage from a single cell battery to portable devices. Using voltage mode architecture with synchronous rectification, Bucks 1 and 2 have the ability to deliver up to 1A, Bucks 3 and 4 up to 800 mA, depending on the input voltage and output voltage, ambient temperature, and the inductor chosen. There are two modes of operation depending on the current required – PWM (Pulse Width Modulation), ECO (ECONomy) mode. The device operates in PWM mode at load currents of approximately 50 mA (typ.) or higher. Lighter output current loads cause the device to automatically switch into ECO mode for reduced current consumption and a longer battery life. Buck1 has DVS capability using external SET1, SET2 inputs while Buck2 has DVS capability via SET3 input. Additional features include soft-start, under voltage protection, current overload protection, and thermal shutdown protection. Only three external power components per buck are required for implementation.

LDO Information

All LDOs can be programmed through serial interface for different output voltage values which are summarized in the output voltage selection tables below.

At the PMU power on, LDOs start up according to the selected startup sequence and the default voltages.

For stability all LDOs need to have external capacitors with recommended value of 1 μ F connected to the output . It is important to select the type of capacitor whose capacitance will in no case (voltage, temperature, etc) be outside of limits specified in the LDO electrical characteristics.

General-Type LDOs

The general LDOs are optimized to supply both analog and digital loads having LOW NOISE (45 μ V_{RMS} for I_{OUT} > 5mA) and excellent PSRR (65 dB at 10 kHz) performance. They can be programmed through the serial interface for different output voltage values.

In sleep mode quiescent current is lowered to 30 μ A for energy saving; in this mode these LDOs should not be loaded by more than 3-5mA of output current.

The innovative design of these general type LDOs reduces the sensitivity to the placement of the output capacitor. These general purpose LDOs do not need the output capacitor to be placed close to the PMU as is the case for normal LDOs. If a (1 μ F or more) capacitor is attached to a circuit load there is no need to place an output capacitor at the PMU.

WILO-Type LDOs

Wide Input Low Output LDOs are designed to enable a lowered output voltage range with voltages down to 0.8V.

Single Input Linear Charger

LP3974 has a built-in Li-Ion/Li-Poly battery management system. Its main features are:

- One input - AC adapter or USB
- Integrated PMOS power routing switch
- CC/CV linear charging
- Selectable battery regulation voltage
- Flexible charging cycle control
- Wide array of charging current options

- Safety timer with time doubling

Charger Function

A charge management system allowing safe charge and maintenance of a Li-Ion battery is implemented on the LP3974.

Following the correct detection of a voltage at the charger input, the charger enters pre-charge mode. In this mode the battery is charged with a small constant current. Settings for the battery current in pre-charge mode, full-rate voltage level, and maximum pre-charge time are pre-set during factory test.

In full charging mode full rate constant current is applied to the battery to raise the voltage to the termination level. The charging current is programmable. When termination voltage is reached, the charger is in constant voltage mode and a constant voltage is maintained. After reaching the end-of-charge condition, the charge management isolates the battery and enters the maintenance mode. A maintenance mode enables the battery voltage to be maintained at the correct level. If restart conditions have been met, then the charge cycle is re-initiated to re-establish the termination voltage level.

Backup Battery Charger

Backup battery charger (BBC) is intended for charging an external coin battery. It consists of Voltage Limited Current Source with 1k Ω output resistor. By default it is always on and the output will be active when the supply voltage is above the UVLO threshold typically 2.7V. The output voltage is programmable to 5 voltages from 2.9V to 3.3V. The default output is set to 3.0V.

It is possible to turn backup battery charger off via registers. BBC has a reverse current protection.

Momentary Power Loss

When power is removed from the PMU and MPL function is enabled (RTC register 0x1B) then the Momentary Power Loss (MPL) timer starts as unexpected powerdown has occurred. This timer is set to the maximum duration allowed for a momentary power loss (RTC register 0x1B). If power is restored before the timer expires, the MPL block will inform the LP3974 control logic about the MPL event.

The MPL circuit is powered from VCOIN pin. MPL timer uses 32.786 kHz RTC crystal oscillator for time base. Host processor needs to enable the MPL function every time the device is powered up.

Analog Switches

Two double pole – double throw switches are integrated on the device and are powered from the VBATT domain. Separate supplies are used for the logic control; LDO9 supplies the power for SW1, and an external supply at VLSW2 supplies the logic on SW2. This arrangement allows some control over the logic thresholds for each switch. These switches are designed for break before make switching, with high speed switching for rail to rail signals.

These devices operate over the entire supply range with a flat response for On-Resistance. The switches are bi-directional and hence the pins NC, NO, and COM can be used as inputs or outputs. An input voltage supply of 1.5V to VBATT may be applied at VLSW2 pin to enable SW2 to operate at lower input logic thresholds.

Overvoltage-Protected LDO Outputs (SAFE1/2)

SAFE1/2 provide a regulated output of 4.7V from the charger DC input. In this way high voltage protection can be provided for low rated USB devices within the system. As it is derived from the CHGIN pin the operational voltage range for this applies, i.e., 4.5V to 7.5V.

RTC Operational Description

This Real Time Clock (RTC) has following features:

- Accurate time counting with fine-grained correction for inaccuracies caused by environment
- Calendar for years 2000-2099 with leap year compensation and automatic day of week calculation
- Two highly customizable alarms

All RTC data is presented in Binary Coded Decimal format. RTC time and alarm registers are user-writable.

Alarms registers are used to set periodical or one-time events. The result of an alarm event depends on the PMU state. If the PMU is in standby, then the alarm causes the PMU to start up. If the PMU is in working mode, then the alarm creates an interrupt.

Interrupts

The LP3974 has 4 main interrupt registers, IRQ1-4. It also has 4 main interrupt masking registers such that if asserted, the particular interrupt that causes an event will be ignored. These interrupts are generated from normal start up / shutdown events, charger events, timed events and warning conditions.

Device Status

The LP3974 has 2 status registers and 2 status masking registers.

Master Reset

The LP3974 has a master reset input which, when brought low, will power down the device for a preset time, then allow the device to power back up. The device will power up with all supplies reset to their default values.

PACKAGING INFORMATION

Orderable Device	Status (1)	Package Type	Package Drawing	Pins	Package Qty	Eco Plan (2)	Lead/Ball Finish	MSL Peak Temp (3)	Op Temp (°C)	Top-Side Markings (4)	Samples
LP3974RME/NOPB	ACTIVE	DSBGA	YQB	100	250	Green (RoHS & no Sb/Br)	SNAG	Level-1-260C-UNLIM	-25 to 85	3974	Samples
LP3974RMX/NOPB	ACTIVE	DSBGA	YQB	100	1000	Green (RoHS & no Sb/Br)	SNAG	Level-1-260C-UNLIM	-25 to 85	3974	Samples

(1) The marketing status values are defined as follows:

ACTIVE: Product device recommended for new designs.

LIFEBUY: TI has announced that the device will be discontinued, and a lifetime-buy period is in effect.

NRND: Not recommended for new designs. Device is in production to support existing customers, but TI does not recommend using this part in a new design.

PREVIEW: Device has been announced but is not in production. Samples may or may not be available.

OBSOLETE: TI has discontinued the production of the device.

(2) Eco Plan - The planned eco-friendly classification: Pb-Free (RoHS), Pb-Free (RoHS Exempt), or Green (RoHS & no Sb/Br) - please check <http://www.ti.com/productcontent> for the latest availability information and additional product content details.

TBD: The Pb-Free/Green conversion plan has not been defined.

Pb-Free (RoHS): TI's terms "Lead-Free" or "Pb-Free" mean semiconductor products that are compatible with the current RoHS requirements for all 6 substances, including the requirement that lead not exceed 0.1% by weight in homogeneous materials. Where designed to be soldered at high temperatures, TI Pb-Free products are suitable for use in specified lead-free processes.

Pb-Free (RoHS Exempt): This component has a RoHS exemption for either 1) lead-based flip-chip solder bumps used between the die and package, or 2) lead-based die adhesive used between the die and leadframe. The component is otherwise considered Pb-Free (RoHS compatible) as defined above.

Green (RoHS & no Sb/Br): TI defines "Green" to mean Pb-Free (RoHS compatible), and free of Bromine (Br) and Antimony (Sb) based flame retardants (Br or Sb do not exceed 0.1% by weight in homogeneous material)

(3) MSL, Peak Temp. -- The Moisture Sensitivity Level rating according to the JEDEC industry standard classifications, and peak solder temperature.

(4) Multiple Top-Side Markings will be inside parentheses. Only one Top-Side Marking contained in parentheses and separated by a "~" will appear on a device. If a line is indented then it is a continuation of the previous line and the two combined represent the entire Top-Side Marking for that device.

Important Information and Disclaimer: The information provided on this page represents TI's knowledge and belief as of the date that it is provided. TI bases its knowledge and belief on information provided by third parties, and makes no representation or warranty as to the accuracy of such information. Efforts are underway to better integrate information from third parties. TI has taken and continues to take reasonable steps to provide representative and accurate information but may not have conducted destructive testing or chemical analysis on incoming materials and chemicals. TI and TI suppliers consider certain information to be proprietary, and thus CAS numbers and other limited information may not be available for release.

In no event shall TI's liability arising out of such information exceed the total purchase price of the TI part(s) at issue in this document sold by TI to Customer on an annual basis.

TAPE AND REEL INFORMATION



QUADRANT ASSIGNMENTS FOR PIN 1 ORIENTATION IN TAPE



*All dimensions are nominal

Device	Package Type	Package Drawing	Pins	SPQ	Reel Diameter (mm)	Reel Width W1 (mm)	A0 (mm)	B0 (mm)	K0 (mm)	P1 (mm)	W (mm)	Pin1 Quadrant
LP3974RME/NOPB	DSBGA	YQB	100	250	178.0	12.4	4.19	4.19	0.76	8.0	12.0	Q1
LP3974RMX/NOPB	DSBGA	YQB	100	1000	178.0	12.4	4.19	4.19	0.76	8.0	12.0	Q1

TAPE AND REEL BOX DIMENSIONS



*All dimensions are nominal

Device	Package Type	Package Drawing	Pins	SPQ	Length (mm)	Width (mm)	Height (mm)
LP3974RME/NOPB	DSBGA	YQB	100	250	210.0	185.0	35.0
LP3974RMX/NOPB	DSBGA	YQB	100	1000	210.0	185.0	35.0

IMPORTANT NOTICE

Texas Instruments Incorporated (TI) reserves the right to make corrections, enhancements, improvements and other changes to its semiconductor products and services per JESD46, latest issue, and to discontinue any product or service per JESD48, latest issue. Buyers should obtain the latest relevant information before placing orders and should verify that such information is current and complete.

TI's published terms of sale for semiconductor products (<http://www.ti.com/sc/docs/stdterms.htm>) apply to the sale of packaged integrated circuit products that TI has qualified and released to market. Additional terms may apply to the use or sale of other types of TI products and services.

Reproduction of significant portions of TI information in TI data sheets is permissible only if reproduction is without alteration and is accompanied by all associated warranties, conditions, limitations, and notices. TI is not responsible or liable for such reproduced documentation. Information of third parties may be subject to additional restrictions. Resale of TI products or services with statements different from or beyond the parameters stated by TI for that product or service voids all express and any implied warranties for the associated TI product or service and is an unfair and deceptive business practice. TI is not responsible or liable for any such statements.

Buyers and others who are developing systems that incorporate TI products (collectively, "Designers") understand and agree that Designers remain responsible for using their independent analysis, evaluation and judgment in designing their applications and that Designers have full and exclusive responsibility to assure the safety of Designers' applications and compliance of their applications (and of all TI products used in or for Designers' applications) with all applicable regulations, laws and other applicable requirements. Designer represents that, with respect to their applications, Designer has all the necessary expertise to create and implement safeguards that (1) anticipate dangerous consequences of failures, (2) monitor failures and their consequences, and (3) lessen the likelihood of failures that might cause harm and take appropriate actions. Designer agrees that prior to using or distributing any applications that include TI products, Designer will thoroughly test such applications and the functionality of such TI products as used in such applications.

TI's provision of technical, application or other design advice, quality characterization, reliability data or other services or information, including, but not limited to, reference designs and materials relating to evaluation modules, (collectively, "TI Resources") are intended to assist designers who are developing applications that incorporate TI products; by downloading, accessing or using TI Resources in any way, Designer (individually or, if Designer is acting on behalf of a company, Designer's company) agrees to use any particular TI Resource solely for this purpose and subject to the terms of this Notice.

TI's provision of TI Resources does not expand or otherwise alter TI's applicable published warranties or warranty disclaimers for TI products, and no additional obligations or liabilities arise from TI providing such TI Resources. TI reserves the right to make corrections, enhancements, improvements and other changes to its TI Resources. TI has not conducted any testing other than that specifically described in the published documentation for a particular TI Resource.

Designer is authorized to use, copy and modify any individual TI Resource only in connection with the development of applications that include the TI product(s) identified in such TI Resource. NO OTHER LICENSE, EXPRESS OR IMPLIED, BY ESTOPPEL OR OTHERWISE TO ANY OTHER TI INTELLECTUAL PROPERTY RIGHT, AND NO LICENSE TO ANY TECHNOLOGY OR INTELLECTUAL PROPERTY RIGHT OF TI OR ANY THIRD PARTY IS GRANTED HEREIN, including but not limited to any patent right, copyright, mask work right, or other intellectual property right relating to any combination, machine, or process in which TI products or services are used. Information regarding or referencing third-party products or services does not constitute a license to use such products or services, or a warranty or endorsement thereof. Use of TI Resources may require a license from a third party under the patents or other intellectual property of the third party, or a license from TI under the patents or other intellectual property of TI.

TI RESOURCES ARE PROVIDED "AS IS" AND WITH ALL FAULTS. TI DISCLAIMS ALL OTHER WARRANTIES OR REPRESENTATIONS, EXPRESS OR IMPLIED, REGARDING RESOURCES OR USE THEREOF, INCLUDING BUT NOT LIMITED TO ACCURACY OR COMPLETENESS, TITLE, ANY EPIDEMIC FAILURE WARRANTY AND ANY IMPLIED WARRANTIES OF MERCHANTABILITY, FITNESS FOR A PARTICULAR PURPOSE, AND NON-INFRINGEMENT OF ANY THIRD PARTY INTELLECTUAL PROPERTY RIGHTS. TI SHALL NOT BE LIABLE FOR AND SHALL NOT DEFEND OR INDEMNIFY DESIGNER AGAINST ANY CLAIM, INCLUDING BUT NOT LIMITED TO ANY INFRINGEMENT CLAIM THAT RELATES TO OR IS BASED ON ANY COMBINATION OF PRODUCTS EVEN IF DESCRIBED IN TI RESOURCES OR OTHERWISE. IN NO EVENT SHALL TI BE LIABLE FOR ANY ACTUAL, DIRECT, SPECIAL, COLLATERAL, INDIRECT, PUNITIVE, INCIDENTAL, CONSEQUENTIAL OR EXEMPLARY DAMAGES IN CONNECTION WITH OR ARISING OUT OF TI RESOURCES OR USE THEREOF, AND REGARDLESS OF WHETHER TI HAS BEEN ADVISED OF THE POSSIBILITY OF SUCH DAMAGES.

Unless TI has explicitly designated an individual product as meeting the requirements of a particular industry standard (e.g., ISO/TS 16949 and ISO 26262), TI is not responsible for any failure to meet such industry standard requirements.

Where TI specifically promotes products as facilitating functional safety or as compliant with industry functional safety standards, such products are intended to help enable customers to design and create their own applications that meet applicable functional safety standards and requirements. Using products in an application does not by itself establish any safety features in the application. Designers must ensure compliance with safety-related requirements and standards applicable to their applications. Designer may not use any TI products in life-critical medical equipment unless authorized officers of the parties have executed a special contract specifically governing such use. Life-critical medical equipment is medical equipment where failure of such equipment would cause serious bodily injury or death (e.g., life support, pacemakers, defibrillators, heart pumps, neurostimulators, and implantables). Such equipment includes, without limitation, all medical devices identified by the U.S. Food and Drug Administration as Class III devices and equivalent classifications outside the U.S.

TI may expressly designate certain products as completing a particular qualification (e.g., Q100, Military Grade, or Enhanced Product). Designers agree that it has the necessary expertise to select the product with the appropriate qualification designation for their applications and that proper product selection is at Designers' own risk. Designers are solely responsible for compliance with all legal and regulatory requirements in connection with such selection.

Designer will fully indemnify TI and its representatives against any damages, costs, losses, and/or liabilities arising out of Designer's non-compliance with the terms and provisions of this Notice.

Looking for pricing, stock, or lifecycle information?

Click below to explore more details on WIN SOURCE:

 [View LP3974RMX/NOPB on WIN SOURCE](#)

 [Texas Instruments](#) Information

Optimize Your Supply Chain with WIN SOURCE Solutions

-  Global Sourcing Solution
-  Obsolete Management
-  Cost Control Management
-  Shortage Management
-  Alternative Solution
-  Excess Inventory Management