



**THE DATASHEET OF  
LTC3530EMS#PBF**



# Wide Input Voltage Synchronous Buck-Boost DC/DC Converter

## FEATURES

- Regulated Output with Input Voltages Above, Below or Equal to the Output
- 1.8V to 5.5V Input and 1.8V to 5.25V Output Range
- 250mA Continuous Output Current from 1.8V  $V_{IN}$
- 600mA Continuous/1A Peak Output Current from Li-Ion
- Single Inductor
- Synchronous Rectification: Up to 96% Efficiency
- Programmable Automatic Burst Mode<sup>®</sup> Operation
- Output Disconnect in Shutdown
- Pin Compatible with the LTC3440
- Programmable Frequency from 300kHz to 2MHz
- <1 $\mu$ A Shutdown Current
- Small Thermally Enhanced 10-Lead (3mm  $\times$  3mm) DFN and 10-Lead MS Packages

## APPLICATIONS

- MP3 Players
- Handheld Instruments
- Digital Cameras
- Smart Phones
- Portable GPS Units
- Miniature Hard Disk Drive Power

## DESCRIPTION

The LTC<sup>®</sup>3530 is a wide  $V_{IN}$  range, highly efficient, fixed frequency, buck-boost DC/DC converter that operates from input voltages above, below or equal to the output voltage. The topology incorporated in the IC provides a continuous transfer function through all operating modes, making the product ideal for single lithium-ion, two-cell alkaline or NiMH applications where the output voltage is within the battery voltage range.

The LTC3530 is pin compatible with the LTC3440 buck-boost DC/DC converter but adds programmable automatic Burst Mode operation and extends the  $V_{IN}/V_{OUT}$  range to 1.8V. Switching frequencies up to 2MHz are programmed with an external resistor. Automatic Burst Mode operation allows the user to program the load current threshold for Burst Mode operation using a single resistor from the BURST pin to GND.

Other features include 1 $\mu$ A shutdown, short circuit protection, programmable soft-start control, current limit and thermal shutdown. The LTC3530 is available in a thermally enhanced 10-lead (3mm  $\times$  3mm) DFN or MSOP package.

LT, LT, LTC, LTM and Burst Mode are registered trademarks of Linear Technology Corporation. All other trademarks are the property of their respective owners. Patents Pending.

## TYPICAL APPLICATION

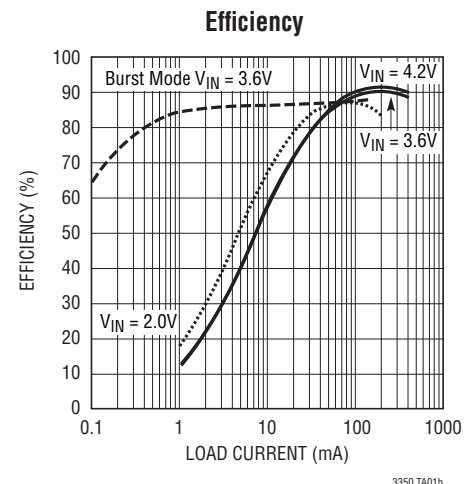
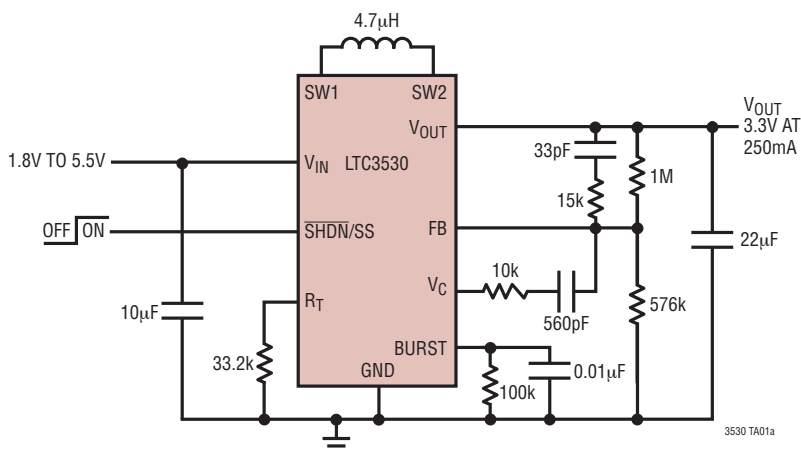

# LTC3530

## ABSOLUTE MAXIMUM RATINGS (Note 1)

$V_{IN}$ , $V_{OUT}$ Voltage .....	-0.3V to 6V	$V_C$ , $R_T$ , FB, $\overline{SHDN/SS}$ , BURST Voltage .....	-0.3V to 6V
SW1, SW2 Voltage		Operating Temperature (Note 2).....	-40°C to 85°C
DC.....	-0.3V to 6V	Maximum Junction Temperature (Note 4).....	125°C
Pulsed < 100ns .....	-0.3V to 7V	Storage Temperature Range.....	-65°C to 150°C

## PIN CONFIGURATION



## ORDER INFORMATION

LEAD FREE FINISH	TAPE AND REEL	PART MARKING	PACKAGE DESCRIPTION	TEMPERATURE RANGE
LTC3530EDD#PBF	LTC3530EDD#TRPBF	LCBH	10-Lead (3mm × 3mm) Plastic DFN	-40°C to 85°C
LTC3530EMS#PBF	LTC3530EMS#TRPBF	LTCBJ	10-Lead Plastic MSOP	-40°C to 85°C

Consult LTC Marketing for parts specified with wider operating temperature ranges.

Consult LTC Marketing for information on non-standard lead based finish parts.

For more information on lead free part marking, go to: <http://www.linear.com/leadfree/>

For more information on tape and reel specifications, go to: <http://www.linear.com/tapeandreeel/>

## ELECTRICAL CHARACTERISTICS

The ● denotes the specifications which apply over the full operating temperature range, otherwise specifications are at  $T_A = 25^{\circ}\text{C}$ .  $V_{IN} = V_{OUT} = 3.6\text{V}$ ,  $R_T = 33.2\text{k}$ , unless otherwise noted.

PARAMETER	CONDITIONS	MIN	TYP	MAX	UNITS
Input Operating Range		● 1.8		5.5	V
Output Voltage Adjust Range		● 1.8		5.25	V
Feedback Voltage		● 1.191	1.215	1.239	V
Feedback Input Current	$V_{FB} = 1.215\text{V}$		1	50	nA
Quiescent Current, Burst Mode Operation	$V_{FB} = 1.215\text{V}$ , BURST = 0V (Note 3)		40	60	$\mu\text{A}$
Quiescent Current, Shutdown	$\overline{SHDN} = 0\text{V}$ , Not Including Switch Leakage		0.1	1	$\mu\text{A}$
Quiescent Current, Active	$V_C = 0\text{V}$ , BURST = 3V (Note 3)		700	1200	$\mu\text{A}$
Input Current Limit		● 1	2		A

3530fb

**ELECTRICAL CHARACTERISTICS** The ● denotes the specifications which apply over the full operating temperature range, otherwise specifications are at  $T_A = 25^\circ\text{C}$ .  $V_{IN} = V_{OUT} = 3.6\text{V}$ ,  $R_T = 33.2\text{k}$ , unless otherwise noted.

PARAMETER	CONDITIONS	MIN	TYP	MAX	UNITS
NMOS Switch Leakage	Switches B and C		0.1	5	$\mu\text{A}$
PMOS Switch Leakage	Switches A and D		0.1	10	$\mu\text{A}$
NMOS Switch On Resistance	Switches B and C		0.21		$\Omega$
PMOS Switch On Resistance	Switches A and D		0.24		$\Omega$
Maximum Duty Cycle	Boost (% Switch C On)	● 80	90		%
	Buck (% Switch A On)	● 100			%
Minimum Duty Cycle		●		0	%
Frequency		● 0.7	1	1.3	MHz
Error Amp AVOL			90		dB
Error Amp Source Current			300		$\mu\text{A}$
Error Amp Sink Current			300		$\mu\text{A}$
Burst Threshold			1		V
Burst Input Current	$V_{BURST} = 5.5\text{V}$			2	$\mu\text{A}$
SHDN/SS Threshold	When IC is Enabled	● 0.4	0.85	1.4	V
	When EA is at Maximum Boost Duty Cycle		1.6		V
SHDN/SS Input Current	$V_{SHDN} = 5.5\text{V}$		0.01	1	$\mu\text{A}$

**Note 1:** Stresses beyond those listed under Absolute Maximum Ratings may cause permanent damage to the device. Exposure to any Absolute Maximum Rating condition for extended periods may affect device reliability and lifetime.

**Note 2:** The LTC3530E is guaranteed to meet performance specifications from  $0^\circ\text{C}$  to  $85^\circ\text{C}$ . Specifications over the  $-40^\circ\text{C}$  to  $85^\circ\text{C}$  operating temperature range are assured by design, characterization and correlations with statistical process controls.

**Note 3:** Current measurements are performed when the outputs are not switching.

**Note 4:** This IC includes overtemperature protection that is intended to protect the device during momentary overload conditions. Junction temperature will exceed  $125^\circ\text{C}$  when overtemperature protection is active. Continuous operation above the specified maximum operating junction temperature may result in device degradation or failure.

**TYPICAL PERFORMANCE CHARACTERISTICS**  $T_A = 25^\circ\text{C}$ , unless otherwise specified.

**Quiescent Current vs  $V_{IN}$  (Fixed Frequency Mode)**

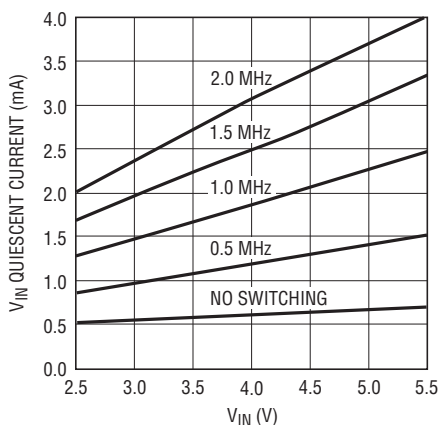

3530 G01

**Burst Mode Quiescent Current**

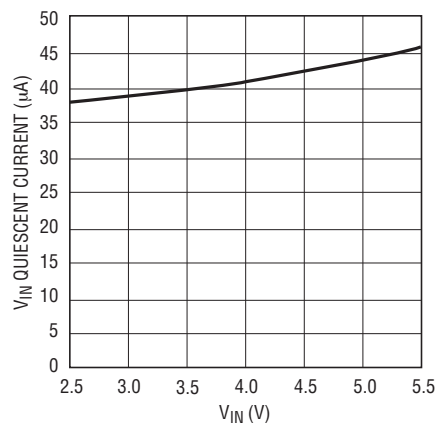

3530 G02

**Peak Current Clamp vs  $V_{IN}$**

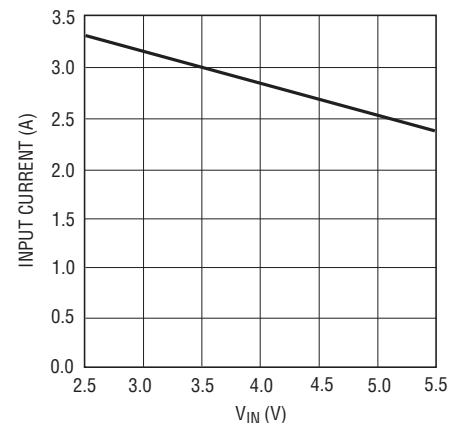

3530 G03

## TYPICAL PERFORMANCE CHARACTERISTICS $T_A = 25^\circ\text{C}$ , unless otherwise specified.

**Automatic Burst Mode Threshold vs  $R_{BURST}$**

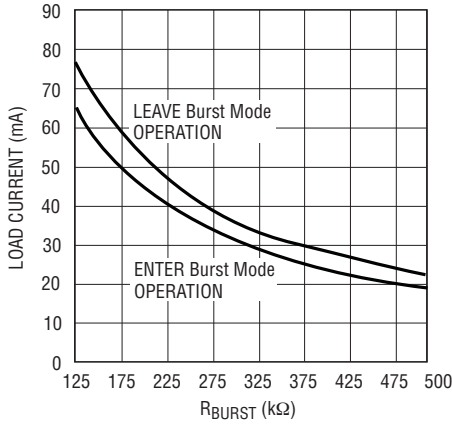

3530 G04

**Minimum Start Voltage vs Temperature**

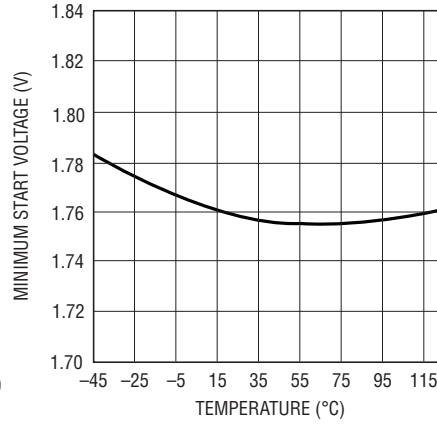

3530 G05

**Average Input Current Limit vs Temperature**

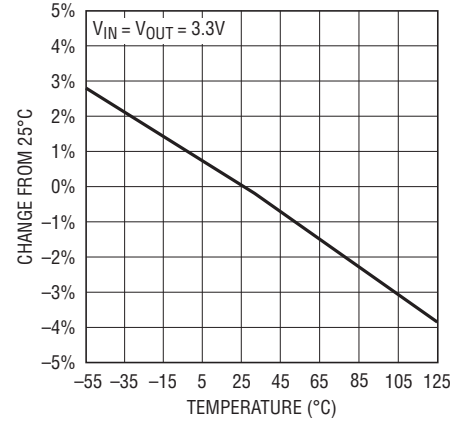

3530 G06

**Frequency Change vs Temperature**

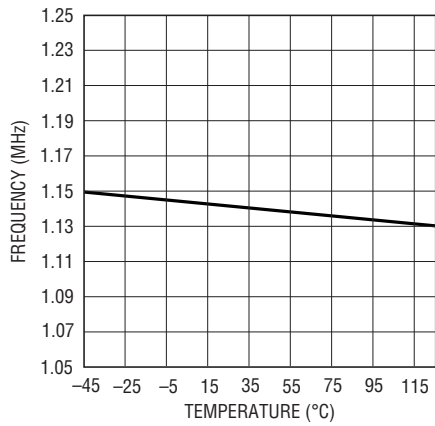

3530 G07

**Feedback Voltage vs Temperature**

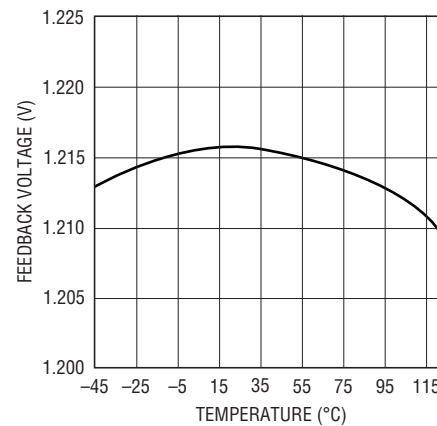

3530 G08

**Switch Pins Before Entering Boost Mode**

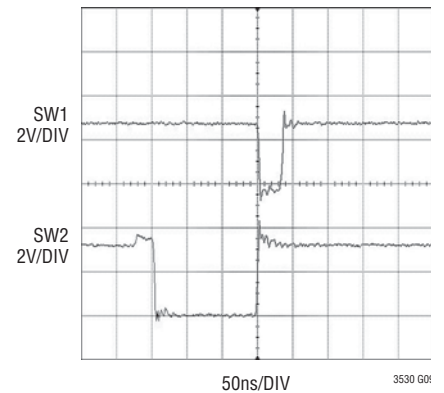

$V_{IN} = 2.9\text{V}$   
 $V_{OUT} = 3.3\text{V AT } 500\text{mA}$

3530 G09

**Switch Pins in Buck-Boost Mode**

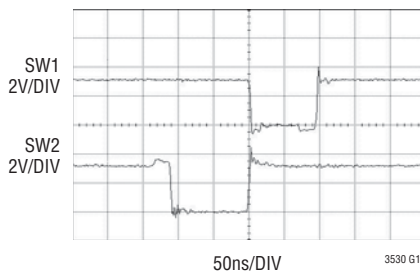

$V_{IN} = 3.3\text{V}$   
 $V_{OUT} = 3.3\text{V AT } 500\text{mA}$

3530 G10

**Switch Pins Entering Buck-Boost Mode**

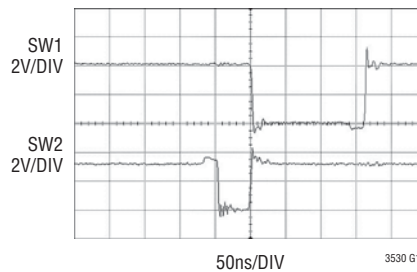

$V_{IN} = 4.2\text{V}$   
 $V_{OUT} = 3.3\text{V AT } 500\text{mA}$

3530 G11

**LTC3530 Output Ripple 500mA Load**

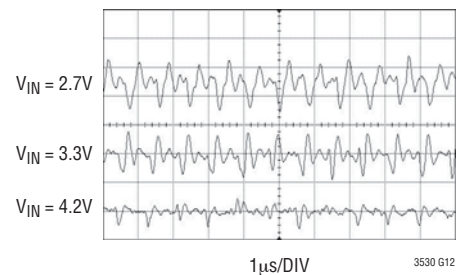

$V_{OUT} = 3.3\text{V}$   
20mV/DIV  
AC COUPLED  
 $C_{OUT} = 22\mu\text{F, X5R CERAMIC}$

3530 G12

## TYPICAL PERFORMANCE CHARACTERISTICS $T_A = 25^\circ\text{C}$ , unless otherwise specified.

### Load Transient Response in Fixed Frequency Mode, No Load to 300mA

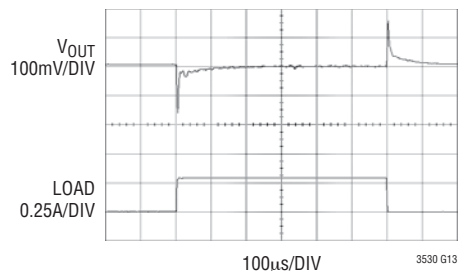

$V_{IN} = 3.6\text{V}$   
 $V_{OUT} = 3.3\text{V}$   
 $C_{OUT} = 22\mu\text{F}$ , X5R CERAMIC

### Load Transient Response in Auto Burst Mode Operation, No Load to 500mA

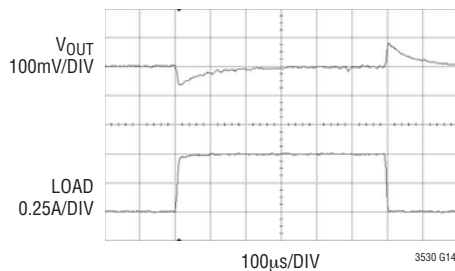

$V_{IN} = 3.6\text{V}$   
 $V_{OUT} = 3.3\text{V}$   
 $C_{OUT} = 47\mu\text{F}$ , X5R CERAMIC +  $100\mu\text{F}$   
 LOW ESR TANTALUM

### Typical Burst Mode Waveforms

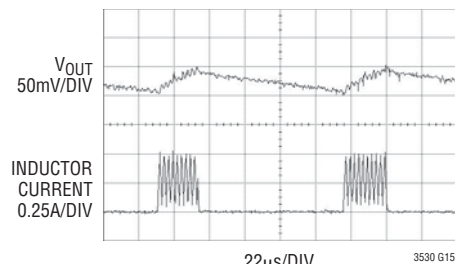

$C_{OUT} = 22\mu\text{F}$ , X5R CERAMIC

### Transition from Burst Mode Operation to Fixed Frequency Mode

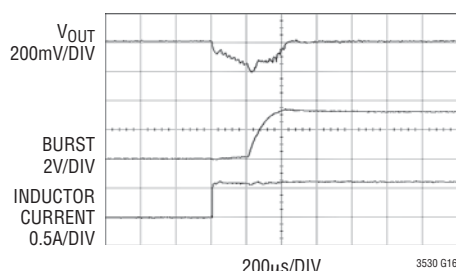

$C_{OUT} = 22\mu\text{F}$ , X5R CERAMIC

### Maximum Output Current vs $V_{IN}$

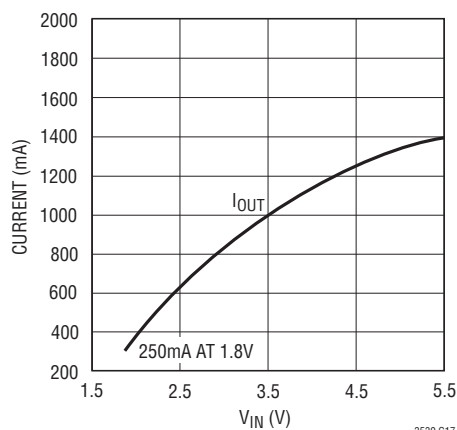

## PIN FUNCTIONS

**$R_T$  (Pin 1):** Programs the Frequency of the Internal Oscillator. Connect a resistor from  $R_T$  to ground.

$$f(\text{kHz}) = 33,170/R_T (\text{k}\Omega)$$

**BURST (Pin 2):** Used to Set the Automatic Burst Mode Threshold. Connect a resistor and capacitor in parallel from this pin to ground. See the Applications Information section for component value selection. For manual control, ground the pin to force Burst Mode operation, connect to  $V_{IN}$  to force fixed frequency PWM mode.

**SW1 (Pin 3):** Switch Pin Where the Internal Switches A and B are Connected. Connect inductor from SW1 to SW2. An optional Schottky diode can be connected from SW1 to ground for a moderate efficiency improvement. Minimize trace length to keep EMI down.

**SW2 (Pin 4):** Switch Pin Where the Internal Switches C and D are Connected. For applications with output voltages over 4.3V, a Schottky diode is required from SW2 to  $V_{OUT}$  to ensure the SW pin does not exhibit excessive voltage.

## PIN FUNCTIONS

**GND (Pin 5):** Ground for the IC.

**V<sub>OUT</sub> (Pin 6):** Output of the Synchronous Rectifier. A filter capacitor is placed from V<sub>OUT</sub> to GND. A ceramic bypass capacitor is recommended as close to the V<sub>OUT</sub> and GND pins as possible.

**V<sub>IN</sub> (Pin 7):** Input Supply Voltage. Internal V<sub>CC</sub> for the IC. A 10μF ceramic capacitor is recommended as close to the V<sub>IN</sub> and GND pins as possible.

**SHDN/SS (Pin 8):** Combined Soft-Start and Shutdown. Applied voltage <0.4V shuts down the IC. Tie to >1.4V to enable the IC and >1.6V to ensure the error amp is not clamped from soft-start. An R-C from the shutdown command signal to this pin will provide a soft-start function by limiting the rise time of V<sub>C</sub>.

**FB (Pin 9):** Feedback Pin. Connect resistor divider tap here. The output voltage can be adjusted from 1.8V to 5.25V. The feedback reference is typically 1.215V.

$$V_{OUT} = 1.215V \cdot \left( 1 + \frac{R1}{R2} \right)$$

**V<sub>C</sub> (Pin 10):** Error Amp Output. An R-C network is connected from this pin to FB for loop compensation. Refer to “Closing the Feedback Loop” section for component selection guidelines. During Burst Mode operation, V<sub>C</sub> is internally clamped.

**Exposed Pad (Pin 11, DD Package Only):** Ground. This pin must be soldered to the PCB and electrically connected to ground.

## BLOCK DIAGRAM

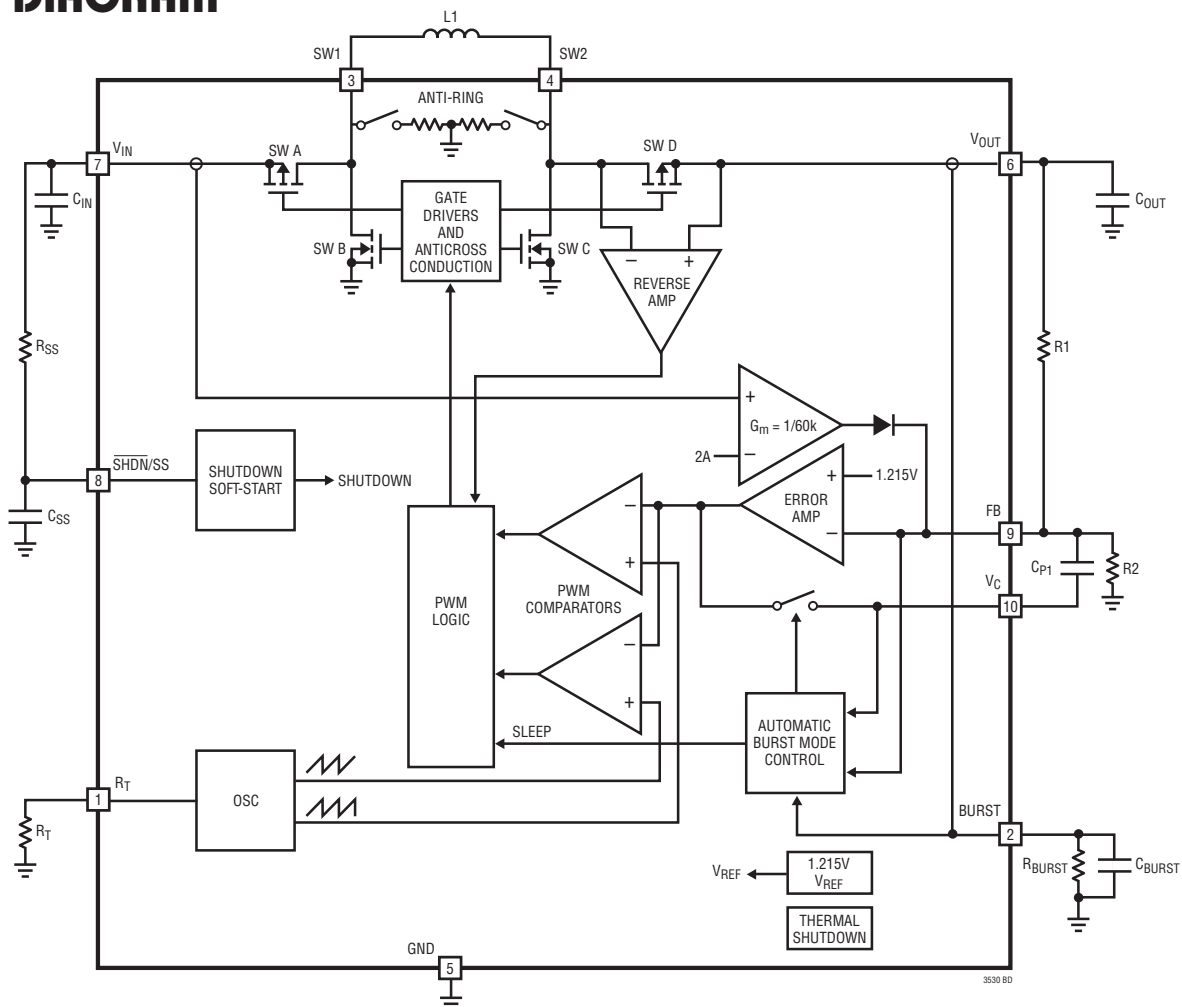

## OPERATION

The LTC3530 provides high efficiency, low noise power for a wide variety of handheld electronic devices. The LTC proprietary topology allows input voltages above, below or equal to the output voltage by properly phasing the output switches. The error amp output voltage on  $V_C$  determines the output duty cycle of the switches. Since  $V_C$  is a filtered signal, it provides rejection of frequencies from well below the switching frequency. The low  $R_{DS(ON)}$ , low gate charge synchronous switches provide high frequency pulse width modulation control at high efficiency. High efficiency is achieved at light loads when Burst Mode operation is entered and the LTC3530's quiescent current drops to a low  $40\mu A$ .

### LOW NOISE FIXED FREQUENCY OPERATION

#### Oscillator

The frequency of operation is programmed by an external resistor from  $R_T$  to ground, according to the following equation:

$$f_{(kHz)} = \frac{33,170}{R_T(k\Omega)}$$

#### Error Amp

The error amplifier is a voltage mode amplifier. The loop compensation components are configured around the amplifier (from FB to  $V_C$ ) to obtain stability of the converter. For improved bandwidth, an additional R-C feed-forward network can be placed across the upper feedback divider resistor. The voltage on  $\overline{SHDN/SS}$  clamps the error amp output,  $V_C$ , to provide a soft-start function.

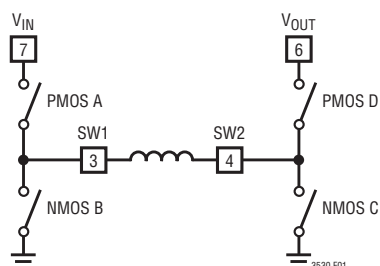

Figure 1. Simplified Diagram of Output Switches

#### Internal Current Limit

There are two different current limit circuits in the LTC3530. Each has internally fixed thresholds which vary inversely with  $V_{IN}$ .

The first circuit is a high speed peak current limit comparator that will shut off switch A once the current exceeds 2.5A typical. The delay to output of this comparator is typically 50ns.

A second amplifier will source current out of FB to drop the output voltage once the peak input current exceeds 2A typical. This method provides a closed loop means of clamping the input current. During conditions where  $V_{OUT}$  is near ground, such as during a short-circuit or during startup, this threshold is cut to 670mA (typ), providing a foldback feature. For this current limit feature to be most effective, the Thevenin resistance from FB to ground should be greater than  $100k\Omega$ .

#### Reverse Current Limit

During fixed frequency operation, the LTC3530 operates in forced continuous conduction mode. The reverse current limit amplifier monitors the inductor current from the output through switch D. Once the negative inductor current exceeds 640mA typical, the LTC3530 will shut off switch D.

#### Four-Switch Control

Figure 1 shows a simplified diagram of how the four internal switches are connected to the inductor,  $V_{IN}$ ,  $V_{OUT}$  and GND. Figure 2 shows the regions of operation for the LTC3530 as a function of the internal control voltage,  $V_{CI}$ .

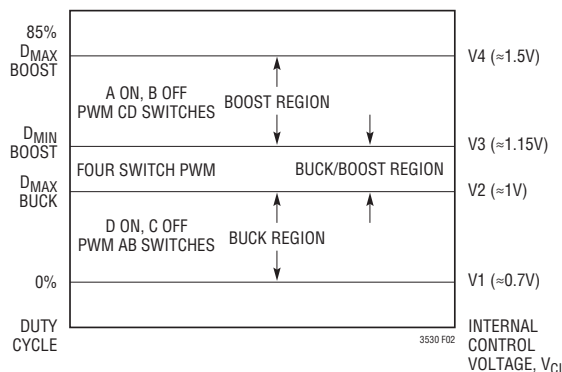

Figure 2. Switch Control vs Internal Control Voltage,  $V_{CI}$

## OPERATION

Depending on the control voltage, the IC will operate in either buck, buck/boost or boost mode. The  $V_{CI}$  voltage is a level shifted voltage from the output of the error amp ( $V_C$ ). The four power switches are properly phased so the transfer between operating modes is continuous, smooth and transparent to the user. When  $V_{IN}$  approaches  $V_{OUT}$  the buck/boost region is reached where the conduction time of the four switch region is typically 150ns. Referring to Figures 1 and 2, the various regions of operation will now be described.

### Buck Region ( $V_{IN} > V_{OUT}$ )

Switch D is always on and switch C is always off during this mode. When the internal control voltage,  $V_{CI}$ , is above voltage V1, output A begins to switch. During the off-time of switch A, synchronous switch B turns on for the remainder of the time. Switches A and B will alternate similar to a typical synchronous buck regulator. As the control voltage increases, the duty cycle of switch A increases until the maximum duty cycle of the converter in buck mode reaches  $D_{MAX\_BUCK}$ , given by:

$$D_{MAX\_BUCK} = 100 - D_{4SW} \%$$

where  $D_{4SW}$  = duty cycle % of the four switch range.

$$D_{4SW} = (150ns \cdot f) \cdot 100 \%$$

where  $f$  = operating frequency, Hz.

Beyond this point the “four switch,” or buck/boost region is reached.

### Buck/Boost or Four Switch ( $V_{IN} \approx V_{OUT}$ )

When the internal control voltage,  $V_{CI}$ , is above voltage V2, switch pair AD remain on for duty cycle  $D_{MAX\_BUCK}$ , and the switch pair AC begins to phase in. As switch pair AC phases in, switch pair BD phases out accordingly. When the  $V_{CI}$  voltage reaches the edge of the buck/boost range, at voltage V3, the AC switch pair completely phase out the BD pair, and the boost phase begins at duty cycle  $D_{4SW}$ . The input voltage,  $V_{IN}$ , where the four switch region begins is given by:

$$V_{IN} = \frac{V_{OUT}}{1 - (150ns \cdot f)}$$

The point at which the four switch region ends is given by:

$$V_{IN} = V_{OUT}(1 - D) = V_{OUT}(1 - 150ns \cdot f) V$$

### Boost Region ( $V_{IN} < V_{OUT}$ )

Switch A is always on and switch B is always off during this mode. When the internal control voltage,  $V_{CI}$ , is above voltage V3, switch pair CD will alternately switch to provide a boosted output voltage. This operation is typical of a synchronous boost regulator. The maximum duty cycle of the converter is limited to 90% typical and is reached when  $V_{CI}$  is above V4.

### BURST MODE OPERATION

Burst mode reduces the LTC3530's quiescent current consumption at light loads and improves overall conversion efficiency, increasing battery life. During Burst Mode operation the LTC3530 delivers energy to the output until it is regulated and then goes into sleep mode where the outputs are off and quiescent current drops to 40 $\mu$ A (typ). In this mode the output ripple has a variable frequency component that depends upon load current, and will typically be about 2% peak-to-peak. Burst Mode operation ripple can be reduced slightly by using more output capacitance (47 $\mu$ F or greater). Another method of reducing Burst Mode operation ripple is to place a small feed-forward capacitor across the upper resistor in the  $V_{OUT}$  feedback divider network (as in Type III compensation).

During the period where the device is delivering energy to the output, the peak switch current will be equal to 450mA typical and the inductor current will terminate at zero current for each cycle. In this mode the typical maximum average output current is given by:

$$I_{MAX(BURST)BUCK} \cong \frac{450mA}{2}; V_{OUT} < V_{IN}$$

$$I_{MAX(BURST)BOOST} \cong \frac{450mA}{2} \cdot \left( \frac{V_{IN}}{V_{OUT}} \right); V_{OUT} > V_{IN}$$

$I_{MAX(BURST) Buck-Boost} \approx 350mA$ ;  $V_{OUT} \approx V_{IN}$ . Since the input and output are connected together for most of the cycle.

## OPERATION

The efficiency below 1mA becomes dominated primarily by the quiescent current. The Burst Mode operation efficiency is given by:

$$\text{EFFICIENCY} \cong \frac{\eta \cdot I_{\text{LOAD}}}{40\mu\text{A} + I_{\text{LOAD}}}$$

where  $\eta$  is typically 90% during Burst Mode operation.

### Automatic Burst Mode Operation Control

Burst Mode operation can be automatic or manually controlled with a single pin. In automatic mode, the IC will enter Burst Mode operation at light load and return to fixed frequency operation at heavier loads. The load current at which the mode transition occurs is programmed using a single external resistor from BURST to ground, according to the following equations:

$$\text{Enter Burst Mode: } I_{\text{BURST}} = \frac{8.8}{R_{\text{BURST}}}$$

$$\text{Leave Burst Mode: } I_{\text{BURST}} = \frac{11.2}{R_{\text{BURST}}}$$

where  $R_{\text{BURST}}$  is in  $k\Omega$  and  $I_{\text{BURST}}$  is the load transition current in Amps. Do not use values of  $R_{\text{BURST}}$  greater than  $500k\Omega$ .

For automatic operation, a filter capacitor must also be connected from BURST to ground. The equation for the minimum capacitor value is:

$$C_{\text{BURST(MIN)}} \geq \frac{C_{\text{OUT}} \cdot V_{\text{OUT}}}{60,000}$$

where  $C_{\text{BURST(MIN)}}$  and  $C_{\text{OUT}}$  are in  $\mu\text{F}$

In the event that a load transient causes FB to drop by more than 4% from the regulation value while in Burst Mode operation, the IC will immediately switch to fixed frequency mode and an internal pull-up will be momentarily applied to BURST, rapidly charging  $C_{\text{BURST}}$ . This prevents the IC from immediately re-entering Burst Mode operation once the output achieves regulation.

### Manual Burst Mode Operation

For manual control of Burst Mode operation, the RC network connected to BURST can be eliminated. To force fixed frequency mode, BURST should be connected to  $V_{\text{IN}}$ . To force Burst Mode operation, BURST should be grounded. When commanding Burst Mode operation manually, the circuit connected to BURST should be able to sink up to 2mA.

For optimum transient response with large dynamic loads, the operating mode should be controlled manually by the host. By commanding fixed frequency operation prior to a sudden increase in load, output voltage droop can be minimized. Note that if the load current applied during forced Burst Mode operation (BURST pin is grounded) exceeds the current that can be supplied, the output voltage will start to droop and the IC will automatically come out of Burst Mode operation and enter fixed frequency mode, raising  $V_{\text{OUT}}$ . Once regulation is achieved, the IC will then enter Burst Mode operation once again, and the cycle will repeat, resulting in about 4% output ripple.

### Burst Mode Operation to Fixed Frequency Transient Response

In Burst Mode operation, the compensation network is not used and  $V_C$  is disconnected from the error amplifier. During long periods of Burst Mode operation, leakage currents in the external components or on the PC board could cause the compensation capacitor to charge (or discharge), which could result in a large output transient when returning to fixed frequency mode of operation, even at the same load current. To prevent this, the LTC3530 incorporates an active clamp circuit that holds the voltage on  $V_C$  at an optimal voltage during Burst Mode operation. This minimizes any output transient when returning to fixed frequency mode operation. For optimum transient response, Type 3 compensation is also recommended to broad band the control loop and roll off past the two pole response of the output LC filter. See Closing the Feedback Loop under Applications Information.

## OPERATION

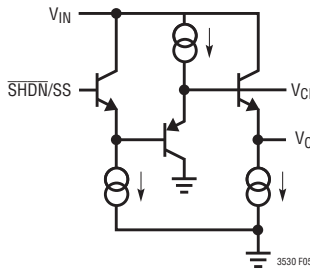

Figure 3.

### Soft-Start

The soft-start function is combined with shutdown. When the SHDN/SS pin is brought above 1V typical, the IC is enabled but the EA duty cycle is clamped from  $V_C$ . A detailed diagram of this function is shown in Figure 3. The components  $R_{SS}$  and  $C_{SS}$  provide a slow ramping voltage on SHDN/SS to provide a soft-start function. To ensure that  $V_C$  is not being clamped, SHDN/SS must be raised above 1.6V.

## COMPONENT SELECTION

### Inductor Selection

The high frequency operation of the LTC3530 allows the use of small surface mount inductors. The inductor ripple current is typically set to 20% to 40% of the maximum inductor current. For a given ripple the inductance terms are given as follows:

$$L_{\text{BOOST}} > \frac{V_{\text{IN(MIN)}} \cdot (V_{\text{OUT}} - V_{\text{IN(MIN)}})}{f \cdot \Delta I_L \cdot V_{\text{OUT}}} \text{H}$$

$$L_{\text{BUCK}} > \frac{V_{\text{OUT}} \cdot (V_{\text{IN(MAX)}} - V_{\text{OUT}})}{f \cdot \Delta I_L \cdot V_{\text{IN(MAX)}}} \text{H}$$

where  $f$  = operating frequency, Hz

$\Delta I_L$  = maximum allowable inductor ripple current, A

$V_{\text{IN(MIN)}}$  = minimum input voltage, V

$V_{\text{IN(MAX)}}$  = maximum input voltage, V

$V_{\text{OUT}}$  = output voltage, V

$I_{\text{OUT(MAX)}}$  = maximum output load current

For high efficiency, choose a ferrite inductor with a high frequency core material to reduce core losses. The inductor should have low ESR (equivalent series resistance) to reduce the  $I^2R$  losses, and must be able to handle the peak inductor current without saturating. Molded chokes or chip inductors usually do not have enough core to support the peak inductor currents in the 1A to 2A region. To minimize radiated noise, use a shielded inductor. See Table 1 for a suggested list of inductor suppliers.

### Output Capacitor Selection

The bulk value of the output filter capacitor is set to reduce the ripple due to charge into the capacitor each cycle. The steady state ripple due to charge is given by:

% Ripple\_Boost =

$$\frac{I_{\text{OUT(MAX)}} \cdot (V_{\text{OUT}} - V_{\text{IN(MIN)}}) \cdot 100}{C_{\text{OUT}} \cdot V_{\text{OUT}}^2 \cdot f} \%$$

% Ripple\_Buck =

$$\frac{1}{8LCf^2} \frac{(V_{\text{IN(MAX)}} - V_{\text{OUT}}) \cdot 100}{V_{\text{IN(MAX)}}} \%$$

where  $C_{\text{OUT}}$  = output filter capacitor in Farads and

$f$  = switching frequency in Hz.

Table 1. Inductor Vendor Information

SUPPLIER	PHONE	FAX	WEB SITE
Coilcraft	(847) 639-6400	(847) 639-1469	www.coilcraft.com
CoEv Magnetics	(800) 227-7040	(650) 361-2508	www.circuitprotection.com/magnetics.asp
Murata	(814) 237-1431 (800) 831-9172	(814) 238-0409	www.murata.com
Sumida	USA: (847) 956-0666 Japan: 81(3) 3607-5111	USA: (847) 956-0702 Japan: 81(3) 3607-5144	www.sumida.com
TDK	(847) 803-6100	(847) 803-6296	www.component.tdk.com
TOKO	(847) 297-0070	(847) 699-7864	www.tokoam.com

## APPLICATIONS INFORMATION

The output capacitance is usually many times larger than the minimum value in order to handle the transient response requirements of the converter. For a rule of thumb, the ratio of the operating frequency to the unity-gain bandwidth of the converter is the amount the output capacitance will have to increase from the above calculations in order to maintain the desired transient response.

The other component of ripple is due to the ESR (equivalent series resistance) of the output capacitor. Low ESR capacitors should be used to minimize output voltage ripple. For surface mount applications, Taiyo Yuden or TDK ceramic capacitors, AVX TPS series tantalum capacitors or Sanyo POSCAP are recommended. See Table 2 for contact information.

### Input Capacitor Selection

Since  $V_{IN}$  is the supply voltage for the IC, as well as the input to the power stage of the converter, it is recommended to place at least a 10 $\mu$ F, low ESR ceramic bypass capacitor close to the  $V_{IN}$  and GND pins. It is also important to minimize any stray resistance from the converter to the battery or other power source.

### Optional Schottky Diodes

Schottky diodes across the synchronous switches B and D are not required ( $V_{OUT} < 4.3V$ ), but provide a lower drop during the break-before-make time (typically 15ns) improving efficiency. Use a surface mount Schottky diode such as an MBRM120T3 or equivalent. Do not use ordinary rectifier diodes, since the slow recovery times will compromise efficiency. For applications with an output voltage above 4.3V, a Schottky diode is required from SW2 to  $V_{OUT}$ .

### Output Voltage < 1.8V

The LTC3530 can operate as a buck converter with output voltages as low as 0.4V. Synchronous switch D is powered from  $V_{OUT}$  and the  $R_{DS(ON)}$  will increase at low output voltages, therefore a Schottky diode is required from SW2 to  $V_{OUT}$  to provide the conduction path to the output. Note that Burst Mode operation is inhibited at output voltages below 1V typical. Note also that if  $V_{OUT}$  is less than 1V, the current limit will be 670mA (typ).

### Output Voltage > 4.3V

A Schottky diode from SW2 to  $V_{OUT}$  is required for output voltages over 4.3V. The diode must be located as close to the pins as possible in order to reduce the peak voltage on SW2 due to the parasitic lead and trace inductance.

### Input Voltage > 4.5V

For applications with input voltages above 4.5V which could exhibit an overload or short-circuit condition, a 2 $\Omega$ /1nF series snubber is required between SW1 and GND. A Schottky diode from SW1 to  $V_{IN}$  should also be added as close to the pins as possible. For the higher input voltages,  $V_{IN}$  bypassing becomes more critical; therefore, a ceramic bypass capacitor as close to the  $V_{IN}$  and GND pins as possible is also required.

### Operating Frequency Selection

Higher operating frequencies allow the use of a smaller inductor and smaller input and output filter capacitors, thus reducing board area and component height. However, higher operating frequencies also increase the IC's total quiescent current due to the gate charge of the four switches, as given by:

$$\text{Buck: } I_q = (0.6 \cdot V_{IN} \cdot f) \text{ mA}$$

$$\text{Boost: } I_q = [0.8 \cdot (V_{IN} + V_{OUT}) \cdot f] \text{ mA}$$

$$\text{Buck/Boost: } I_q = [f \cdot (1.4 \cdot V_{IN} + 0.4 \cdot V_{OUT})] \text{ mA}$$

Table 2. Capacitor Vendor Information

SUPPLIER	PHONE	FAX	WEB SITE
AVX	(803) 448-9411	(803) 448-1943	www.avxcorp.com
Murata	(814) 237-1431, (800) 831-9172	(814) 238-0409	www.murata.com
Sanyo	(619) 661-6322	(619) 661-1055	www.sanyovideo.com
Taiyo Yuden	(408) 573-4150	(408) 573-4159	www.t-yuden.com
TDK	(847) 803-6100	(847) 803-6296	www.component.tdk.com

3530fb

## APPLICATIONS INFORMATION

where  $f$  = switching frequency in MHz. Therefore frequency selection is a compromise between the optimal efficiency and the smallest solution size.

### Closing the Feedback Loop

The LTC3530 incorporates voltage mode PWM control. The control to output gain varies with operation region (buck, boost, buck/boost), but is usually no greater than 15. The output filter exhibits a double pole response, as given by:

$$f_{\text{FILTER\_POLE}} = \frac{1}{2 \cdot \pi \cdot \sqrt{L \cdot C_{\text{OUT}}}} \text{ Hz}$$

(in buck mode)

$$f_{\text{FILTER\_POLE}} = \frac{V_{\text{IN}}}{2 \cdot V_{\text{OUT}} \cdot \pi \cdot \sqrt{L \cdot C_{\text{OUT}}}} \text{ Hz}$$

(in boost mode)

where  $L$  is in henries and  $C_{\text{OUT}}$  is in farads.

The output filter zero is given by:

$$f_{\text{FILTER\_ZERO}} = \frac{1}{2 \cdot \pi \cdot R_{\text{ESR}} \cdot C_{\text{OUT}}} \text{ Hz}$$

where  $R_{\text{ESR}}$  is the equivalent series resistance of the output capacitor.

A troublesome feature in boost mode is the right-half plane zero (RHP), given by:

$$f_{\text{RHPZ}} = \frac{V_{\text{IN}}^2}{2 \cdot \pi \cdot I_{\text{OUT}} \cdot L \cdot V_{\text{OUT}}} \text{ Hz}$$

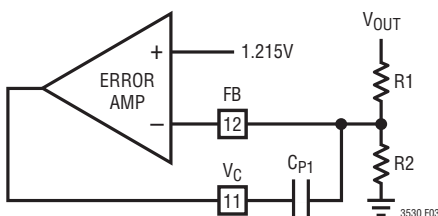

Figure 4. Error Amplifier with Type I Compensation

The loop gain is typically rolled off before the RHP zero frequency.

A simple Type I compensation network can be incorporated to stabilize the loop, but at a cost of reduced bandwidth and slower transient response. To ensure proper phase margin using Type I compensation, the loop must be crossed over a decade before the LC double pole. The unity-gain frequency of the error amplifier with the Type I compensation is given by:

$$f_{\text{UG}} = \frac{1}{2 \cdot \pi \cdot R1 \cdot C_{\text{P1}}} \text{ Hz (referring to Figure 4).}$$

Most applications demand an improved transient response to allow a smaller output filter capacitor. To achieve a higher bandwidth, Type III compensation is required, providing two zeros to compensate for the double-pole response of the output filter. Referring to Figure 5, the location of the poles and zeros are given by:

$$f_{\text{POLE1}} \approx \frac{1}{2 \cdot \pi \cdot 32,000 \cdot R1 \cdot C_{\text{P1}}} \text{ Hz}$$

(which is extremely close to DC)

$$f_{\text{ZERO1}} = \frac{1}{2 \cdot \pi \cdot R_Z \cdot C_{\text{P1}}} \text{ Hz}$$

$$f_{\text{ZERO2}} = \frac{1}{2 \cdot \pi \cdot R1 \cdot C_{\text{Z1}}} \text{ Hz}$$

$$f_{\text{POLE2}} = \frac{1}{2 \cdot \pi \cdot R_Z \cdot C_{\text{P2}}} \text{ Hz}$$

where resistance is in ohms and capacitance is in farads.

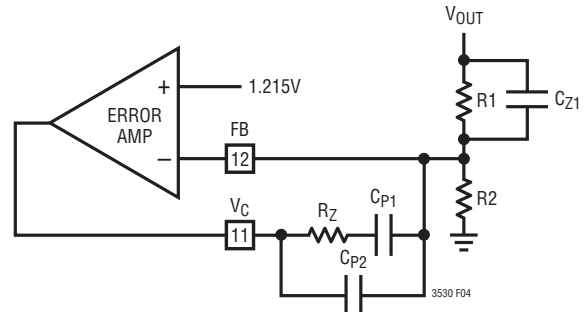
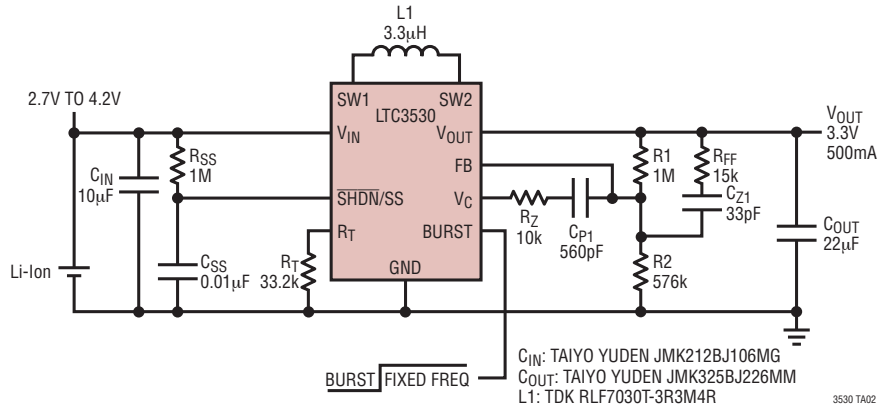

Figure 5. Error Amplifier with Type III Compensation

3530fb

# TYPICAL APPLICATIONS

1MHz Li-Ion to 3.3V at 500mA Converter with Manual Mode Control



1MHz Li-Ion to 3.3V/600mA Converter with USB Power Input Option, Li Battery Charger and Power Path Management.

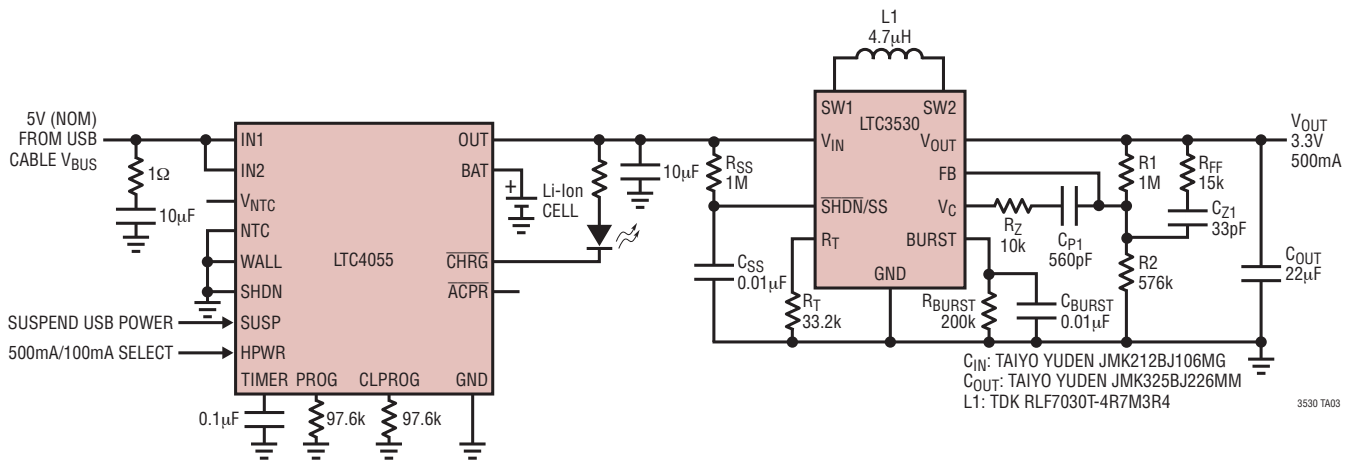

## TYPICAL APPLICATIONS

### High Efficiency Li-Ion Powered Constant Current Lumiled Driver

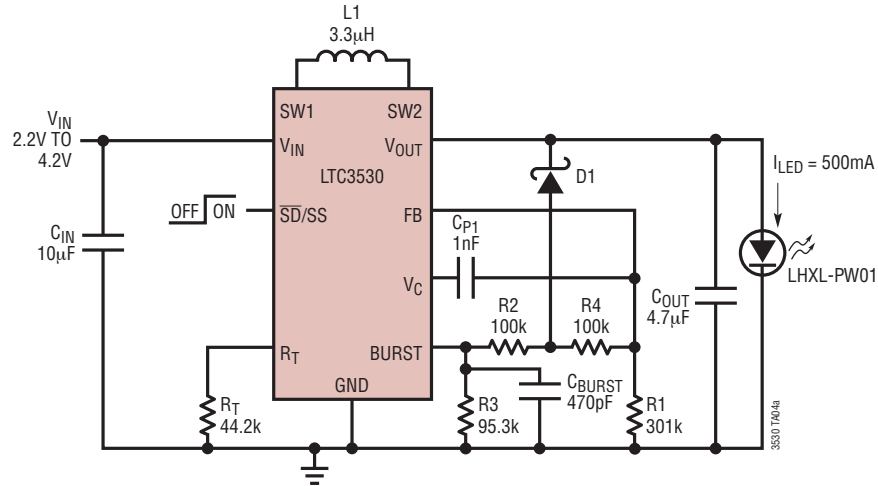

$R2 = R1/1.5$   
 $I_{LED} = \frac{12,810 (R1+R2+R3+R4)}{R1 \cdot R3}$   
 $D1 = BAT54$

$C_{IN} = \text{TAIYO YUDEN JMK212BJ106MG}$   
 $C_{OUT} = \text{TAIYO YUDEN JMK325BJ475MM}$

Lumiled Driver Efficiency vs LED Current

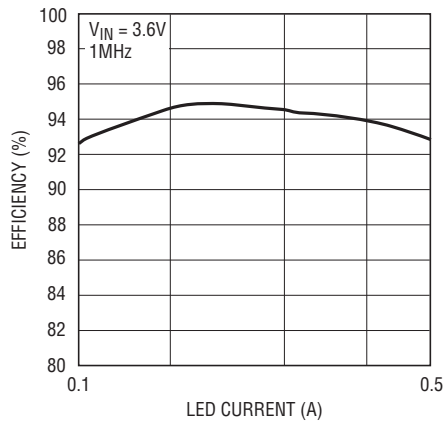

3530 TA04b

# PACKAGE DESCRIPTION

## DD Package 10-Lead Plastic DFN (3mm x 3mm) (Reference LTC DWG # 05-08-1695)

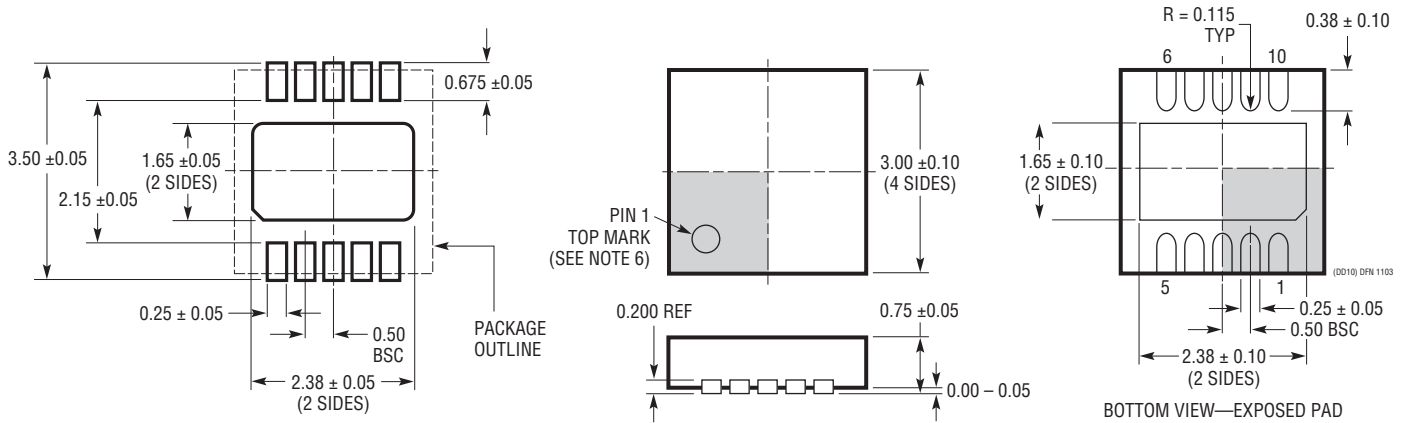

RECOMMENDED SOLDER PAD PITCH AND DIMENSIONS

**NOTE:**

1. DRAWING TO BE MADE A JEDEC PACKAGE OUTLINE M0-229 VARIATION OF (WEED-2). CHECK THE LTC WEBSITE DATA SHEET FOR CURRENT STATUS OF VARIATION ASSIGNMENT
2. DRAWING NOT TO SCALE
3. ALL DIMENSIONS ARE IN MILLIMETERS
4. DIMENSIONS OF EXPOSED PAD ON BOTTOM OF PACKAGE DO NOT INCLUDE MOLD FLASH. MOLD FLASH, IF PRESENT, SHALL NOT EXCEED 0.15mm ON ANY SIDE
5. EXPOSED PAD SHALL BE SOLDER PLATED
6. SHADED AREA IS ONLY A REFERENCE FOR PIN 1 LOCATION ON THE TOP AND BOTTOM OF PACKAGE

## MS Package 10-Lead Plastic MSOP (Reference LTC DWG # 05-08-1661)

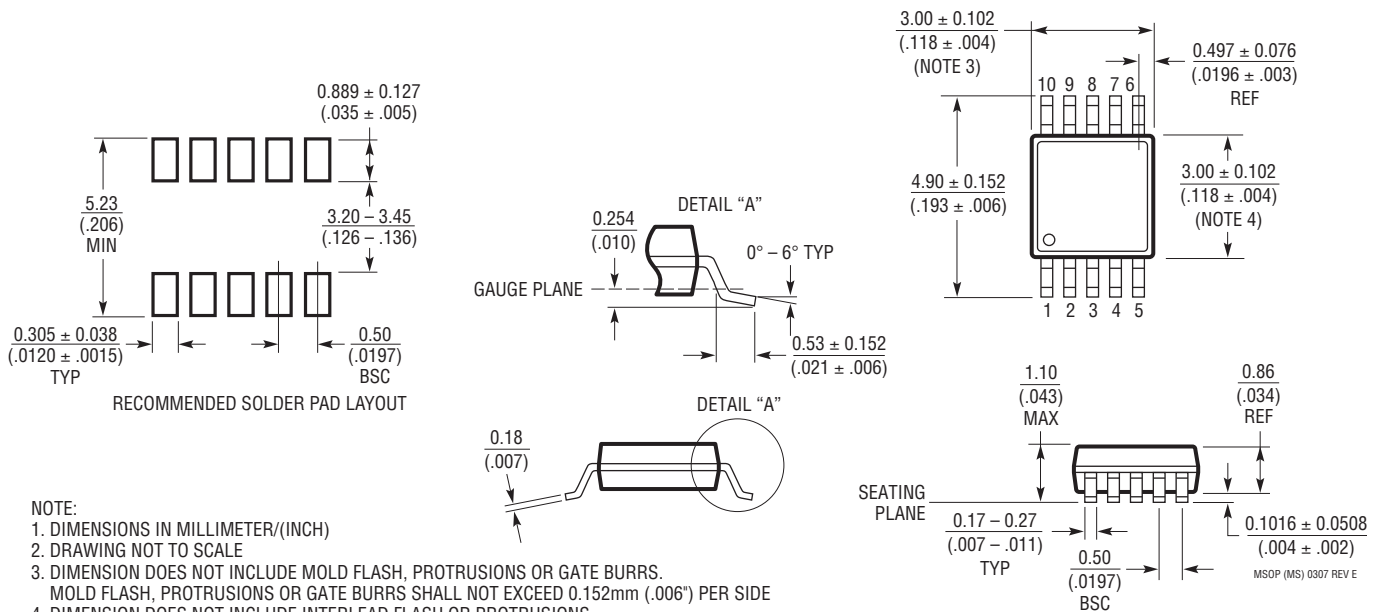

RECOMMENDED SOLDER PAD LAYOUT

**NOTE:**

1. DIMENSIONS IN MILLIMETER/(INCH)
2. DRAWING NOT TO SCALE
3. DIMENSION DOES NOT INCLUDE MOLD FLASH, PROTRUSIONS OR GATE BURRS. MOLD FLASH, PROTRUSIONS OR GATE BURRS SHALL NOT EXCEED 0.152mm (.006") PER SIDE
4. DIMENSION DOES NOT INCLUDE INTERLEAD FLASH OR PROTRUSIONS. INTERLEAD FLASH OR PROTRUSIONS SHALL NOT EXCEED 0.152mm (.006") PER SIDE
5. LEAD COPLANARITY (BOTTOM OF LEADS AFTER FORMING) SHALL BE 0.102mm (.004") MAX

## TYPICAL APPLICATION

### USB to 5V Converter with Output Disconnect

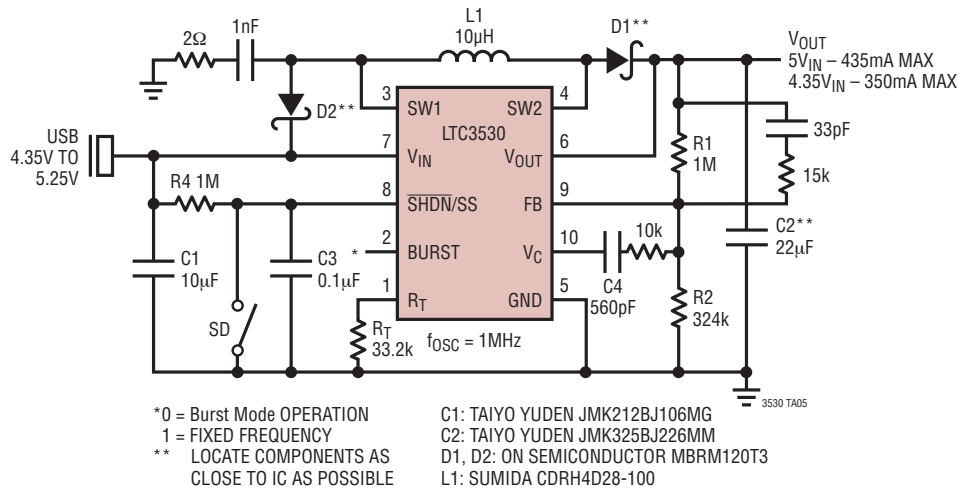

## RELATED PARTS

PART NUMBER	DESCRIPTION	COMMENTS
LTC3400/LTC3400B	600mA ( $I_{SW}$ ), 1.2MHz Synchronous Step-Up DC/DC Converter	$V_{IN}$ : 0.85V to 5V, $V_{OUT(MAX)}$ = 5V, $I_Q$ = 19 $\mu$ A/300 $\mu$ A, $I_{SD}$ < 1 $\mu$ A, ThinSOT Package
LTC3401/LTC3402	1A/2A ( $I_{SW}$ ), 3MHz Synchronous Step-Up DC/DC Converter	$V_{IN}$ : 0.5V to 5V, $V_{OUT(MAX)}$ = 5V, $I_Q$ = 38mA, $I_{SD}$ < 1 $\mu$ A, MS Package
LTC3406/LTC3406B	600mA ( $I_{OUT}$ ), 1.5MHz Synchronous Step-Up DC/DC Converter	$V_{IN}$ : 2.5V to 5.5V, $V_{OUT(MIN)}$ = 0.6V, $I_Q$ = 20 $\mu$ A, $I_{SD}$ $\leq$ 1 $\mu$ A, ThinSOT Package
LTC3407	600mA ( $I_{OUT}$ ), 1.5MHz Dual Synchronous Step-Up DC/DC Converter	$V_{IN}$ : 2.5V to 5.5V, $V_{OUT(MIN)}$ = 0.6V, $I_Q$ = 40 $\mu$ A, $I_{SD}$ $\leq$ 1 $\mu$ A, MS Package
LTC3411	1.25A ( $I_{OUT}$ ), 4MHz Synchronous Step-Up DC/DC Converter	$V_{IN}$ : 2.5V to 5.5V, $V_{OUT(MIN)}$ = 0.8V, $I_Q$ = 60 $\mu$ A, $I_{SD}$ $\leq$ 1 $\mu$ A, MS Package
LTC3412	2.5A ( $I_{OUT}$ ), 4MHz Synchronous Step-Up DC/DC Converter	$V_{IN}$ : 2.5V to 5.5V, $V_{OUT(MIN)}$ = 0.8V, $I_Q$ = 60 $\mu$ A, $I_{SD}$ $\leq$ 1 $\mu$ A, TSSOP16E Package
LTC3421	3A ( $I_{SW}$ ), 3MHz Synchronous Step-Up DC/DC Converter	$V_{IN}$ : 0.5V to 4.5V, $V_{OUT(MAX)}$ = 5.25V, $I_Q$ = 12 $\mu$ A, $I_{SD}$ < 1 $\mu$ A, QFN Package
LTC3425	5A ( $I_{SW}$ ), 8MHz Multiphase Synchronous Step-Up DC/DC Converter	$V_{IN}$ : 0.5V to 4.5V, $V_{OUT(MAX)}$ = 5.25V, $I_Q$ = 12 $\mu$ A, $I_{SD}$ < 1 $\mu$ A, QFN Package
LTC3429	600mA ( $I_{SW}$ ), 500kHz Synchronous Step-Up DC/DC Converter	$V_{IN}$ : 0.5V to 4.4V, $V_{OUT(MAX)}$ = 5V, $I_Q$ = 20 $\mu$ A, $I_{SD}$ < 1 $\mu$ A, QFN Package
LTC3440	600mA ( $I_{OUT}$ ), 2MHz Synchronous Buck-Boost DC/DC Converter	$V_{IN}$ : 2.5V to 5.5V, $V_{OUT(MAX)}$ = 5.5V, $I_Q$ = 25 $\mu$ A, $I_{SD}$ < 1 $\mu$ A, MS, DFN Package
LTC3441	600mA ( $I_{OUT}$ ), 2MHz Synchronous Buck-Boost DC/DC Converter	$V_{IN}$ : 2.5V to 5.5V, $V_{OUT(MAX)}$ = 5.5V, $I_Q$ = 25 $\mu$ A, $I_{SD}$ < 1 $\mu$ A, DFN Package
LTC3442/LTC3443	1.2A ( $I_{OUT}$ ), Synchronous Buck-Boost DC/DC Converters, LTC3442 (1MHz), LTC3443 (600kHz)	$V_{IN}$ : 2.4V to 5.5V, $V_{OUT(MAX)}$ = 5.25V, $I_Q$ = 28 $\mu$ A, $I_{SD}$ < 1 $\mu$ A, MS Package
LTC3444	500mA ( $I_{OUT}$ ), 1.5MHz Synchronous Buck-Boost DC/DC Converter with Wide $V_{OUT}$ Range	$V_{IN}$ : 2.7V to 5.5V, $V_{OUT}$ = 0.5V to 5.25V, 3mm x 3mm DFN Package, Ideal for WCDMA PA Bias
LTC3532	500mA ( $I_{OUT}$ ), 2MHz Synchronous Buck-Boost DC/DC Converter	$V_{IN}$ : 2.4V to 5.5V, $V_{OUT(MAX)}$ = 5.25V, $I_Q$ = $I_{SD}$ < 1 $\mu$ A, DFN Package

ThinSOT is a trademark of Linear Technology Corporation.

## Looking for pricing, stock, or lifecycle information?

Click below to explore more details on WIN SOURCE:

 [View LTC3530EMS#PBF on WIN SOURCE](#)

 [Linear Technology](#) Information

## Optimize Your Supply Chain with WIN SOURCE Solutions

-  Global Sourcing Solution
-  Obsolete Management
-  Cost Control Management
-  Shortage Management
-  Alternative Solution
-  Excess Inventory Management