



**THE DATASHEET OF
ST7FLITEUS2M6TR**



8-bit MCU with single voltage Flash memory, ADC, timers

Features

■ Memories

- 1 Kbytes single-voltage Flash Program memory with readout protection, ICP and IAP)
10 K write/erase cycles guaranteed data retention: 20 years at 55 °C
- 128 bytes RAM

■ Clock, Reset and Supply management

- 3-level low-voltage supervisor (LVD) and auxiliary voltage detector (AVD) for safe power-on/off
- Clock sources: internal trimmable 8 MHz RC oscillator, internal low power, low frequency RC oscillator or external clock
- Five power saving modes: Halt, Auto-wakeup from Halt, Active-halt, Wait, Slow

■ Interrupt management

- 11 interrupt vectors plus TRAP and RESET
- 5 external interrupt lines (or 5 vectors)

■ I/O ports

- 5 multifunctional bidirectional I/C lines
- 1 additional Output line
- 6 alternate function lines
- 5 high sink outputs

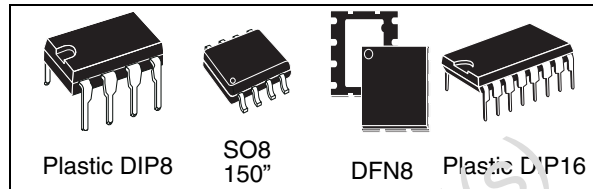

■ 2 Timers

- One 8-bit Lite timer (LT) with prescaler including: watchdog, one realtime base and one 8-bit input capture.
- One 12-bit auto-reload timer (AT) with output compare function and PWM

■ A/D Converter

- 10-bit resolution for 0 to V_{DD}
- 5 input channels

■ Instruction Set

- 8-bit data manipulation
- 63 basic instructions with illegal opcode detection
- 17 main addressing modes
- 8x8 unsigned multiply instruction

■ Development Tools

- Full hardware/software development package
- Debug module

Table 1. Device summary

Features	ST7LITEUS2	ST7LITEUS5
Program memory	1 Kbytes	
RAM (static)	128 (64) bytes	
Peripherals	LT Timer w/ Wdg, AT Timer w/ 1 PWM	
ADC	-	10-bit
Operating Supply	2.4 to 3.3 V @f _{CPU} =4 MHz, 3.3 to 5.5 V @f _{CPU} =8 MHz	
CPU Frequency	up to 8 MHz RC	
Operating Temperature	-40 to +85 °C / -40 to 125 °C	
Packages	SO8 150°, Plastic DIP8, DFN8, Plastic DIP16 ⁽¹⁾	

1. For development or tool prototyping purposes only. Not orderable in production quantities.

Contents

1	Introduction	11
2	Pin description	12
3	Register and memory map	15
4	Flash program memory	18
4.1	Introduction	18
4.2	Main features	18
4.3	Programming modes	18
4.3.1	In-circuit programming (ICP)	18
4.3.2	In application programming (IAP)	19
4.4	I ² C interface	19
4.5	Memory protection	20
4.5.1	Readout protection	20
4.5.2	Flash Write/Erase protection	21
4.6	Related documentation	21
4.7	Register description	22
4.7.1	Flash Control/Status register (FCSR)	22
5	Central processing unit	23
5.1	Introduction	23
5.2	Main features	23
5.3	CPU registers	23
5.3.1	Accumulator (A)	23
5.3.2	Index registers (X and Y)	23
5.3.3	Program counter (PC)	23
5.3.4	Condition Code register (CC)	24
5.3.5	Stack Pointer (SP)	26
6	Supply, reset and clock management	28
6.1	Main features	28
6.2	Internal RC oscillator adjustment	28

6.3	Register description	30
6.3.1	Main Clock Control/Status register (MCCSR)	30
6.3.2	RC Control register (RCCR)	31
6.3.3	System Integrity (SI) Control/status register (SICSR)	31
6.3.4	AVD Threshold Selection register (AVDTHCR)	32
6.3.5	Clock Controller Control/Status register (CKCNTCSR)	32
6.4	Reset sequence manager (RSM)	35
6.4.1	Introduction	35
6.4.2	Asynchronous external RESET pin	36
6.4.3	External Power-on reset	36
6.4.4	Internal low voltage detector (LVD) reset	36
6.4.5	Internal watchdog reset	37
6.5	Register description	37
6.5.1	Multiplexed I/O Reset Control register 1 (MUXCR1)	37
6.5.2	Multiplexed I/O Reset Control register 0 (MUXCR0)	37
7	Interrupts	39
7.1	Non maskable software interrupt	39
7.2	External interrupts	40
7.3	Peripheral interrupts	40
7.3.1	External Interrupt Control register 1 (EICR1)	41
7.3.2	External Interrupt Control register 2 (EICR2)	42
7.4	System integrity management (SI)	43
7.4.1	Low voltage detector (LVD)	43
7.4.2	Auxiliary voltage detector (AVD)	45
7.4.3	Low power modes	46
7.4.4	Register description	46
8	Power saving modes	48
8.1	Introduction	48
8.2	Slow mode	49
8.3	Wait mode	49
8.4	Active-halt and Halt modes	50
8.4.1	Active-halt mode	51
8.4.2	Halt mode	52
8.5	Auto-wakeup from Halt mode	54

8.5.1	Register description	57
9	I/O ports	59
9.1	Introduction	59
9.2	Functional description	59
9.2.1	Input modes	59
9.2.2	Output modes	60
9.2.3	Alternate functions	61
9.3	Unused I/O pins	63
9.4	Low power modes	63
9.5	Interrupts	63
9.6	I/O port implementation	64
10	On-chip peripherals	65
10.1	Lite timer (LT)	65
10.1.1	Introduction	65
10.1.2	Main features	65
10.1.3	Functional description	66
10.1.4	Low power modes	68
10.1.5	Interrupts	68
10.1.6	Register description	69
10.2	12-bit auto-reload timer (AT)	71
10.2.1	Introduction	71
10.2.2	Main features	71
10.2.3	Functional description	71
10.2.4	Low power modes	73
10.2.5	Interrupts	74
10.2.6	Register description	74
10.3	10-bit A/D converter (ADC)	79
10.3.1	Introduction	79
10.3.2	Main features	79
10.3.3	Functional description	79
10.3.4	Low power modes	81
10.3.5	Interrupts	82
10.3.6	Register description	82

11	Instruction set	84
11.1	ST7 addressing modes	84
11.1.1	Inherent mode	85
11.1.2	Immediate	86
11.1.3	Direct	86
11.1.4	Indexed mode (no offset, short, long)	86
11.1.5	Indirect modes (short, long)	87
11.1.6	Indirect indexed modes (short, long)	87
11.1.7	Relative modes (direct, indirect)	88
11.2	Instruction groups	88
11.2.1	Illegal opcode reset	89
12	Electrical characteristics	92
12.1	Parameter conditions	92
12.1.1	Minimum and maximum values	92
12.1.2	Typical values	92
12.1.3	Typical curves	92
12.1.4	Loading capacitor	92
12.1.5	Pin input voltage	93
12.2	Absolute maximum ratings	93
12.3	Operating conditions	94
12.3.1	General operating conditions	94
12.3.2	Operating conditions with low voltage detector (LVD)	95
12.3.3	Auxiliary voltage detector (AVD) thresholds	96
12.3.4	Internal RC oscillator	96
12.4	Supply current characteristics	99
12.4.1	Supply current	99
12.4.2	Internal RC oscillator supply current characteristics	100
12.4.3	On-chip peripherals	103
12.5	Clock and timing characteristics	103
12.6	Memory characteristics	104
12.7	EMC characteristics	105
12.7.1	Functional EMS (electromagnetic susceptibility)	105
12.7.2	Electromagnetic Interference (EMI)	106
12.7.3	Absolute maximum ratings (electrical sensitivity)	106
12.8	I/O port pin characteristics	108

12.8.1	General characteristics	108
12.8.2	Output driving current characteristics	109
12.9	Control pin characteristics	113
12.10	ADC characteristics	115
13	Package characteristics	118
13.1	Package mechanical data	118
13.2	Thermal characteristics	122
14	Device configuration and ordering information	123
14.1	Option bytes	123
14.1.1	OPTION BYTE 1	123
14.1.2	OPTION BYTE 0	124
14.2	Ordering information	125
14.3	Development tools	128
14.3.1	Starter kits	128
14.3.2	Development and debugging tools	128
14.3.3	Programming tools	128
14.3.4	Order codes for development and programming tools	128
14.4	ST7 application notes	129
15	Known limitations	133
16	Revision history	134

List of tables

Table 1.	Device summary	1
Table 2.	Device pin description	14
Table 3.	Hardware register map	16
Table 4.	FLASH register map and reset values	22
Table 5.	Predefined RC oscillator calibration values	28
Table 6.	Internal RC prescaler selection bits	32
Table 7.	Clock register map and reset values	33
Table 8.	Multiplexed IO register map and reset values	38
Table 9.	Interrupt mapping	41
Table 10.	Interrupt sensitivity bits	42
Table 11.	Description of low power modes	46
Table 12.	Description of interrupt events	46
Table 13.	System integrity register map and reset values	47
Table 14.	Enabling/disabling Active-halt and Halt modes	50
Table 15.	Configuring the dividing factor	58
Table 16.	AWU register map and reset values	58
Table 17.	DR register value and output pin status	60
Table 18.	I/O port mode options	62
Table 19.	I/O port configurations	62
Table 20.	Effect of low power modes on I/O ports	63
Table 21.	Description of interrupt events	63
Table 22.	Port configuration	64
Table 23.	I/O port register map and reset values	64
Table 24.	Description of low power modes	68
Table 25.	Interrupt events	68
Table 26.	Lite timer register map and reset values	70
Table 27.	Description of low power modes	73
Table 28.	Interrupt events	74
Table 29.	Counter clock selection	75
Table 30.	Register map and reset values	77
Table 31.	Effect of low power modes	81
Table 32.	Channel selection	82
Table 33.	Configuring the ADC clock speed	83
Table 34.	ADC register map and reset values	83
Table 35.	Description of addressing modes	84
Table 36.	ST7 addressing mode overview	84
Table 37.	Instructions supporting inherent addressing mode	85
Table 38.	Instructions supporting inherent immediate addressing mode	86
Table 39.	Instructions supporting direct, indexed, indirect and indirect indexed addressing modes	87
Table 40.	Instructions supporting relative modes	88
Table 41.	ST7 instruction set	88
Table 42.	Illegal opcode detection	89
Table 43.	Voltage characteristics	93
Table 44.	Current characteristics	94
Table 45.	Thermal characteristics	94
Table 46.	General operating conditions	94
Table 47.	Operating characteristics with LVD	95
Table 48.	Operating characteristics with AVD	96

Table 49.	Voltage drop between AVD flag set and LVD reset generation	96
Table 50.	Internal RC oscillator characteristics (5.0 V calibration)	97
Table 51.	Internal RC oscillator characteristics (3.3 V calibration)	97
Table 52.	Supply current characteristics	99
Table 53.	Internal RC oscillator supply current	100
Table 54.	On-chip peripheral characteristics	103
Table 55.	General timings	103
Table 56.	Auto-wakeup RC oscillator	103
Table 57.	RAM and Hardware registers	104
Table 58.	Flash Program memory	104
Table 59.	EMC characteristics	105
Table 60.	EMI characteristics	106
Table 61.	Absolute maximum ratings	106
Table 62.	Electrical sensitivities	107
Table 63.	General characteristics	108
Table 64.	Output driving current characteristics	109
Table 65.	Asynchronous RESET pin characteristics	114
Table 66.	10-bit ADC characteristics	115
Table 67.	ADC accuracy with VDD = 3.3 to 5.5 V	116
Table 68.	ADC accuracy with VDD = 2.7 to 3.3 V	116
Table 69.	ADC accuracy with VDD = 2.4V to 2.7V	116
Table 70.	8-lead very thin fine pitch dual flat no-lead package mechanical data	118
Table 71.	8-pin plastic small outline package, 150-mil width, package mechanical data	119
Table 72.	8-pin plastic dual in-line package, 300-mil width, package mechanical data	120
Table 73.	16-pin plastic dual in-line package, 300-mil width, package mechanical data	121
Table 74.	Thermal characteristics	122
Table 75.	Startup clock selection	124
Table 76.	LVD threshold configuration	124
Table 77.	Definition of sector 0 size	124
Table 79.	Supported order codes	125
Table 80.	Development tool order codes for the ST7LITEUSx family	129
Table 81.	ST7 application notes	129
Table 82.	Document revision history	134

List of figures

Figure 1.	General block diagram	11
Figure 2.	8-pin SO and Plastic DIP package pinout	12
Figure 3.	8-pin DFN package pinout	12
Figure 4.	16-pin package pinout	13
Figure 5.	Memory map	15
Figure 6.	Typical I ² C interface	20
Figure 7.	CPU registers	24
Figure 8.	Stack manipulation example	27
Figure 9.	Clock switching	30
Figure 10.	Clock management block diagram	34
Figure 11.	Reset sequence phases	35
Figure 12.	Reset block diagram	36
Figure 13.	Reset sequences	37
Figure 14.	Interrupt processing flowchart	40
Figure 15.	Low voltage detector vs reset	44
Figure 16.	Reset and supply management block diagram	44
Figure 17.	Using the AVD to monitor VDD	45
Figure 18.	Power saving mode transitions	48
Figure 19.	Slow mode clock transition	49
Figure 20.	Wait mode flowchart	50
Figure 21.	Active-halt timing overview	51
Figure 22.	Active-halt mode flowchart	52
Figure 23.	Halt timing overview	53
Figure 24.	Halt mode flowchart	53
Figure 25.	AWUFH mode block diagram	54
Figure 26.	AWUF Halt timing diagram	55
Figure 27.	AWUFH mode flowchart	56
Figure 28.	I/O port general block diagram	61
Figure 29.	Interrupt I/O port state transitions	64
Figure 30.	Lite timer block diagram	66
Figure 31.	Watchdog timing diagram	67
Figure 32.	Input capture timing diagram	68
Figure 33.	Block diagram	71
Figure 34.	PWM function	72
Figure 35.	PWM signal example	73
Figure 36.	ADC block diagram	80
Figure 37.	Pin loading conditions	92
Figure 38.	Pin input voltage	93
Figure 39.	fCPU maximum operating frequency versus V _{DD} supply voltage	95
Figure 40.	Typical accuracy with RCCR=RCCR0 vs VDD= 2.4-6.0 V and temperature	98
Figure 41.	Typical accuracy with RCCR=RCCR1 vs VDD= 2.4-6.0V and temperature	98
Figure 42.	Typical IDD in run mode vs. internal clock frequency and VDD	101
Figure 43.	Typical IDD in WFI mode vs. internal clock frequency and VDD	101
Figure 44.	Typical IDD in Slow, Slow-wait and Active-halt mode vs VDD & int RC = 8 MHz	101
Figure 45.	I _{DD} vs temp @VDD 5 V & int RC = 8 MHz	102
Figure 46.	I _{DD} vs temp @VDD 5 V & int RC = 4 MHz	102
Figure 47.	I _{DD} vs temp @VDD 5 V & int RC = 2 MHz	102

Figure 48.	Two typical applications with unused I/O pin	108
Figure 49.	Typical IPU vs. VDD with VIN=VSSI.	109
Figure 50.	Typical VOL at VDD = 2.4 V (standard pins)	110
Figure 51.	Typical VOL at VDD = 3 V (standard pins)	110
Figure 52.	Typical VOL at VDD = 5 V (standard pins)	110
Figure 53.	Typical VOL at VDD = 2.4 V (HS pins)	111
Figure 54.	Typical VOL at VDD = 3 V (HS pins)	111
Figure 55.	Typical VOL at VDD = 5 V (HS pins)	111
Figure 56.	Typical VDD-VOH at VDD = 2.4 V (HS pins)	112
Figure 57.	Typical VDD-VOH at VDD = 3 V (HS pins)	112
Figure 58.	Typical VDD-VOH at VDD = 5 V (HS pins)	112
Figure 59.	Typical VOL vs. VDD (HS pins)	113
Figure 60.	Typical VDD-VOH vs. VDD (HS pins)	113
Figure 61.	RESET pin protection when LVD is enabled	114
Figure 62.	RESET pin protection when LVD is disabled	115
Figure 63.	Typical application with ADC	116
Figure 64.	ADC accuracy characteristics	117
Figure 65.	8-lead very thin fine pitch dual flat no-lead package outline	118
Figure 66.	8-pin plastic small outline package, 150-mil width package outline	119
Figure 67.	8-pin plastic dual in-line package, 300-mil width package outline	120
Figure 68.	16-pin plastic dual in-line package, 300-mil width, package outline	121
Figure 69.	Option list	127

1 Introduction

The ST7LITEUS2 and ST7LITEUS5 are members of the ST7 microcontroller family. All ST7 devices are based on a common industry-standard 8-bit core, featuring an enhanced instruction set.

The ST7LITEUS2 and ST7LITEUS5 feature FLASH memory with byte-by-byte In-Circuit Programming (ICP) and In-Application Programming (IAP) capability.

Under software control, the ST7LITEUS2 and ST7LITEUS5 can be placed in Wait, Slow, or Halt mode, reducing power consumption when the application is in idle or standby state.

The enhanced instruction set and addressing modes of the ST7 offer both power and flexibility to software developers, enabling the design of highly efficient and compact application code. In addition to standard 8-bit data management, all ST7 microcontrollers feature true bit manipulation, 8x8 unsigned multiplication and indirect addressing modes.

For easy reference, all parametric data are located in [Section 12 on page 32](#).

The devices feature an on-chip debug module (DM) to support in-circuit debugging (ICD). For a description of the DM registers, refer to the ST7 I²C protocol reference manual.

Figure 1. General block diagram

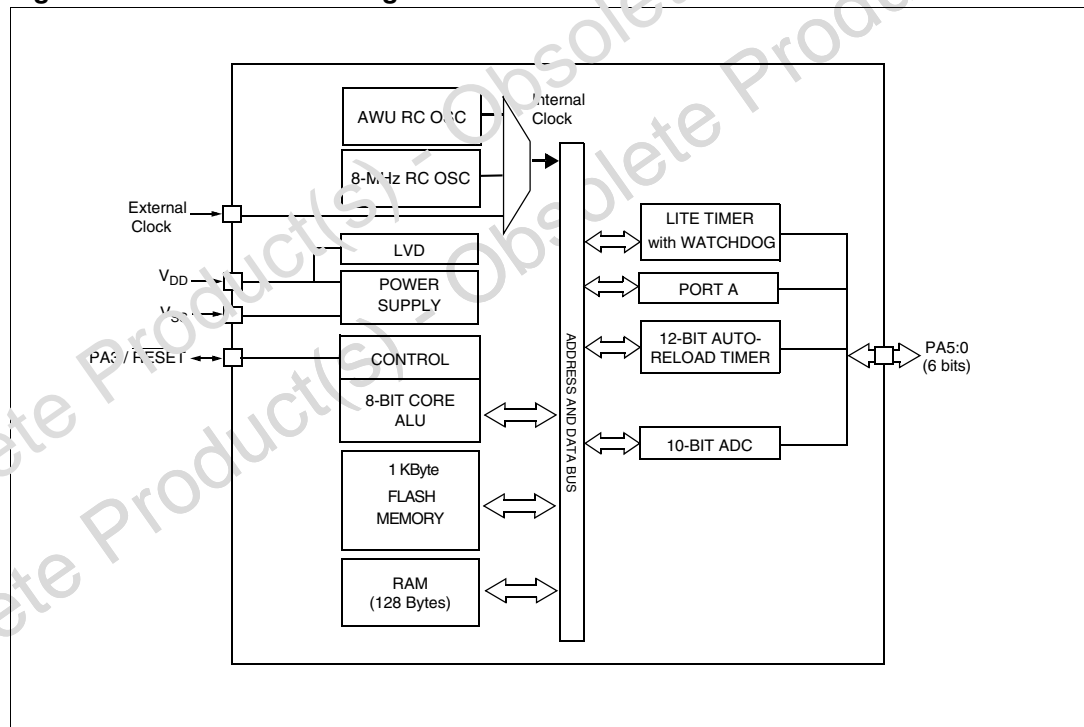

2 Pin description

Figure 2. 8-pin SO and Plastic DIP package pinout

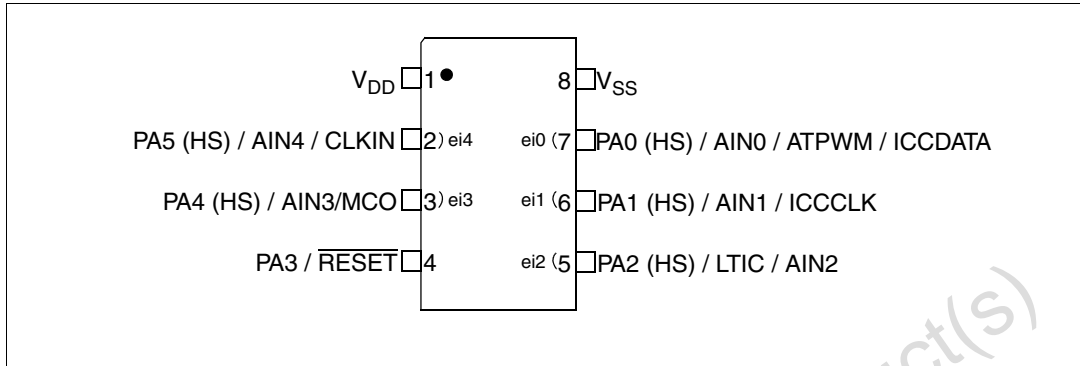

1. HS: High sink capability.
2. eix : associated external interrupt vector

Figure 3. 8-pin DFN package pinout

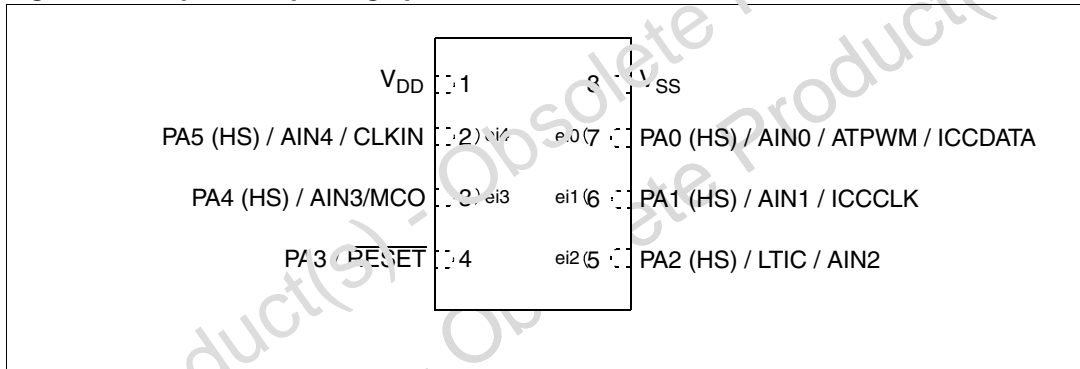

1. HS: High sink capability.
2. eix : associated external interrupt vector

Figure 4. 16-pin package pinout

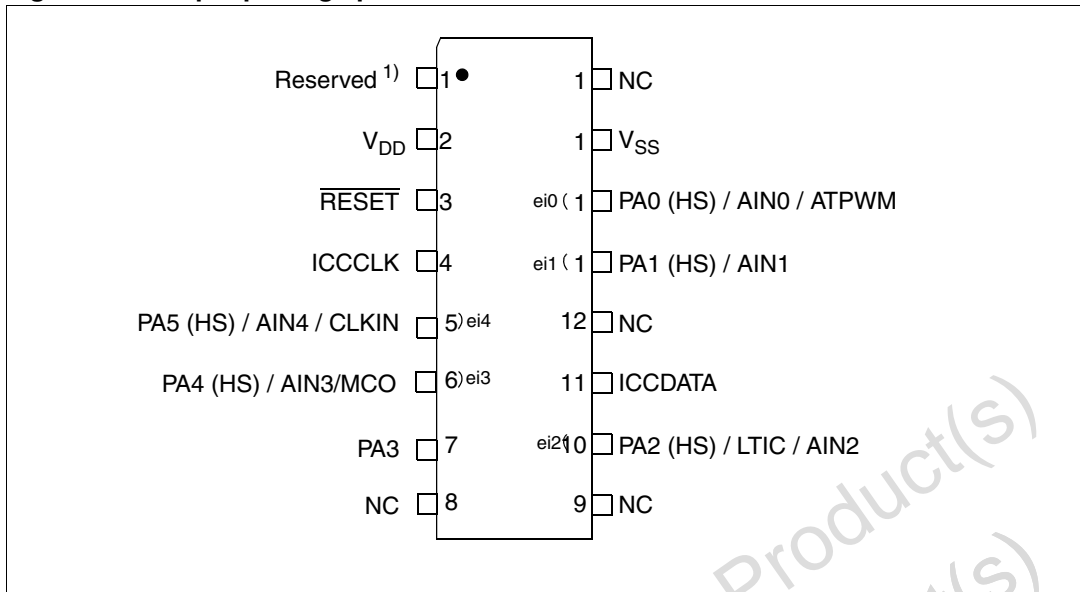

1. Reserved pins must be tied to ground.
2. The differences versus the 8-pin packages are listed below:
 The I²C signals (ICCCLK and ICCDATA) are mapped on dedicated pins.
 The RESET signal is mapped on a dedicated pin. It is not multiplexed with PA3.
 PA3 pin is always configured as output. Any change on multiplexed IO reset control registers (MUXCR1 and MUXCR2) will have no effect on PA3 functionality. Refer to [Section 6.5: Register description on page 37](#).

Legend/abbreviations for Table 2

Type: I = input, O = output, S = supply

In/Output level: $C_T = \text{CMOS } 0.3 V_{DD} / 0.7 V_{DD}$ with input trigger

Output level: HS = High sink (on N-buffer only)

Port and control configuration

- Input: float = floating, wpu = weak pull-up, int = interrupt, ana = analog
- Output: OD = open drain, PP = push-pull

The RESET configuration of each pin is shown in bold which is valid as long as the device is in reset state.

Table 2. Device pin description

Pin no.	Pin name	Type	Level		Port/control						Main function (after reset)	Alternate function	
			Input	Output	Input				Output				
					float	wpu	int	ana	OD	PP			
1	V _{DD}	S										Main power supply	
2	PA5/AIN4/CLKIN	I/O	C _T	HS	X	ei4	X	X	X			Port A5	Analog input 4 or External Clock Input
3	PA4/AIN3/MCO	I/O	C _T	HS	X	ei3	X	X	X			Port A4	Analog input 3 or main clock output
4	PA3/ RESET ⁽¹⁾	O				X			X	X		Port A3	RESET ⁽¹⁾
5	PA2/AIN2/LTIC	I/O	C _T	HS	X	ei2	X	X	X			Port A2	Analog input 2 or Lite Timer Input Capture
6	PA1/AIN1/ICCLK	I/O	C _T	HS	X	ei1	X	X	X			Port A1	Analog input 1 or In Circuit Communication Clock Caution: During normal operation this pin must be pulled-up, internally or externally (external pull-up of 10k mandatory in noisy environment). This is to avoid entering I ² C mode unexpectedly during a reset. In the application, even if the pin is configured as output, any reset will put it back in pull-up
7	PA0/AIN0/ATPWM/ICCDATA	I/O	C _T	HS	X	ei0	X	X	X			Port A0	Analog input 0 or Auto-Reload Timer PWM or In Circuit Communication Data
8	V _{SS}	S											Ground

1. After a reset, the multiplexed PA3/**RESET** pin will act as **RESET**. To configure this pin as output (Port A3), write 55h to MUXCR0 and AAh to MUXCR1. For further details, please refer to [Section 6.5 on page 37](#).

3 Register and memory map

As shown in [Figure 5](#), the MCU is capable of addressing 64K bytes of memories and I/O registers.

The available memory locations consist of 128 bytes of register locations, 128 bytes of RAM and 1 Kbyte of user program memory. The RAM space includes up to 64 bytes for the stack from 00C0h to 00FFh.

The highest address bytes contain the user reset and interrupt vectors.

The Flash memory contains two sectors (see [Figure 5](#)) mapped in the upper part of the ST7 addressing space so the reset and interrupt vectors are located in Sector 0 (FE00h-FFFFh).

The size of Flash Sector 0 and other device options are configurable by option byte.

Warning: Memory locations marked as “Reserved” must never be accessed. Accessing a reserved area can have unpredictable effects on the device.

Figure 5. Memory map

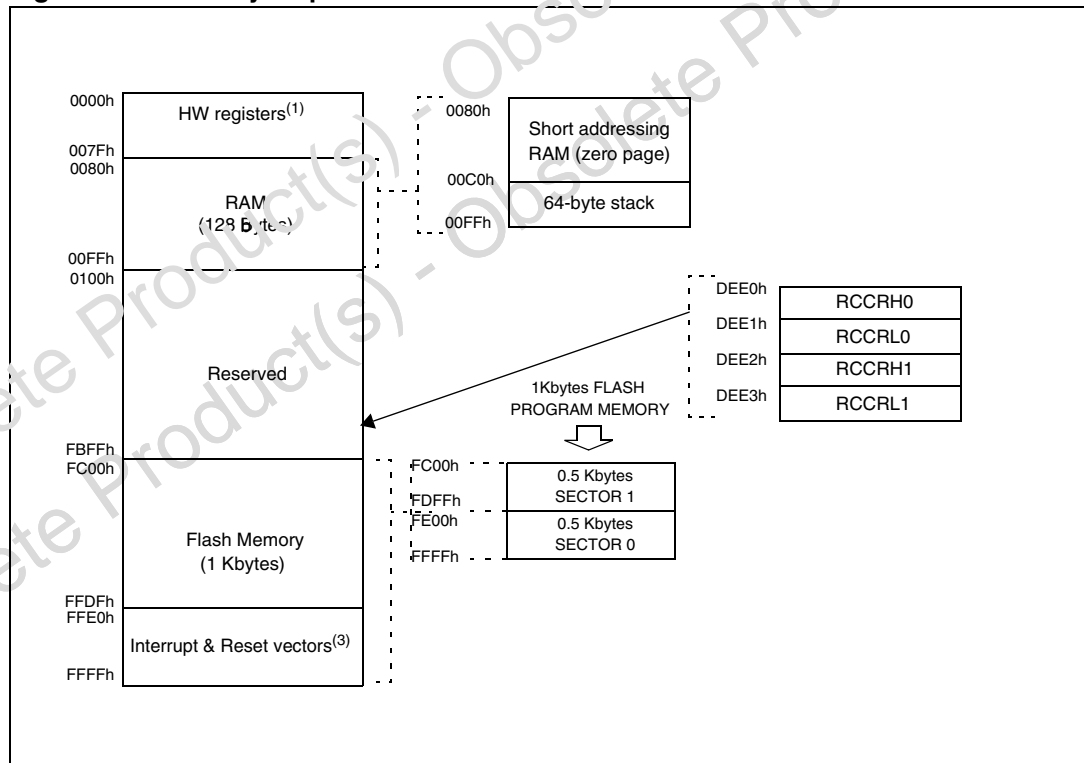

1. See [Table 3](#).
2. See [Section 6.2 on page 28](#) for the description of RCCRHx registers.
3. See [Table 9](#).

Table 3. Hardware register map (1)

Address	Block	Register label	Register name	Reset status	Remarks
0000h 0001h 0002h	Port A	PADR PADDR PAOR	Port A Data register Port A Data Direction register Port A Option register	00h ⁽²⁾ 08h 02h ⁽³⁾	R/W R/W R/W
0003h- 000Ah	Reserved area (8 bytes)				
000Bh 000Ch	LITE TIMER	LTCSR LTICR	Lite Timer Control/Status register Lite Timer Input Capture register	0xh 00h	R/W Read only
000Dh 000Eh 000Fh 0010h 0011h 0012h 0013h	AUTO- RELOAD TIMER	ATCSR CNTRH CNTRL ATRH ATRL PWMCR PWM0CSR	Timer Control/Status register Counter register High Counter register Low Auto-Reload register High Auto-Reload register Low PWM Output Control register PWM 0 Control/Status register	00h 00h 00h 00h 00h 00h 00h	R/W Read only Read only R/W R/W R/W R/W
0014h to 0016h	Reserved area (3 bytes)				
0017h 0018h	AUTO- RELOAD TIMER	DCR0H DCR0L	PWM 0 Duty Cycle register High PWM 0 Duty Cycle register Low	00h 00h	R/W R/W
0019h to 002Eh	Reserved area (22 bytes)				
002Fh	FLASH	FCSR	Flash Control/Status register	00h	R/W
0030h to 0033h	Reserved area (4 bytes)				
0034h 0035h 0036h	ADC	ADCSR ADC0RH ADC0RL	A/D Control Status register A/D Data register High A/D Data register Low	00h xxh 00h	R/W Read only R/W
0037h	ITC	EICR1	External Interrupt Control register 1	00h	R/W
0038h	MCC	MCCSR	Main Clock Control/Status register	00h	R/W
0039h 003Ah	Clock and Reset	RCCR SICSR	RC oscillator Control register System Integrity Control/Status register	FFh 0000 0x00b	R/W R/W
003Bh to 003Ch	Reserved area (2 bytes)				
003Dh	ITC	EICR2	External Interrupt Control register 2	00h	R/W
003Eh	AVD	AVDTHCR	AVD Threshold Selection register	03h	R/W
003Fh	Clock controller	CKCNTCSR	Clock Controller Control/Status register	09h	R/W
0040h to 0046h	Reserved area (7 bytes)				
0047h 0048h	MuxIO- reset	MUXCR0 MUXCR1	Mux IO-Reset Control register 0 Mux IO-Reset Control register 1	00h 00h	R/W R/W

Table 3. Hardware register map (continued)⁽¹⁾

Address	Block	Register label	Register name	Reset status	Remarks
0049h 004Ah	AWU	AWUPR AWUCSR	AWU Prescaler register AWU Control/Status register	FFh 00h	R/W R/W
004Bh 004Ch 004Dh 004Eh 004Fh 0050h	DM ⁽⁴⁾	DMCR DMSR DMBK1H DMBK1L DMBK2H DMBK2L	DM Control register DM Status register DM Breakpoint register 1 High DM Breakpoint register 1 Low DM Breakpoint register 2 High DM Breakpoint register 2 Low	00h 00h 00h 00h 00h 00h	R/W R/W R/W R/W R/W R/W
0051h to 007Fh	Reserved area (47 bytes)				

1. Legend: x=undefined, R/W=read/write
2. The contents of the I/O port DR registers are readable only in output configuration. In input configuration, the values of the I/O pins are returned instead of the DR register contents.
3. The bits associated with unavailable pins must always keep their reset value.
4. For a description of the DM registers, see the ST7 I²C Protocol Reference Manual.

4 Flash program memory

4.1 Introduction

The ST7 single voltage extended Flash (XFlash) is a non-volatile memory that can be electrically erased and programmed either on a byte-by-byte basis or up to 32 bytes in parallel.

The XFlash devices can be programmed off-board (plugged in a programming tool) or on-board using in-circuit programming or in-application programming.

The array matrix organization allows each sector to be erased and reprogrammed without affecting other sectors.

4.2 Main features

- ICP (in-circuit programming)
- IAP (in-application programming)
- ICT (in-circuit testing) for downloading and executing user application test patterns in RAM
- Sector 0 size configurable by option byte
- Readout and write protection

4.3 Programming modes

The ST7 can be programmed in three different ways:

- Insertion in a programming tool
In this mode, FLASH sectors 0 and 1 and option byte row can be programmed or erased.
- In-circuit programming
In this mode, FLASH sectors 0 and 1 and option byte row can be programmed or erased without removing the device from the application board.
- In-application programming
In this mode, sector 1 can be programmed or erased without removing the device from the application board and while the application is running.

4.3.1 In-circuit programming (ICP)

ICP uses a protocol called I²C (in-circuit communication) which allows an ST7 plugged on a printed circuit board (PCB) to communicate with an external programming device connected via cable. ICP is performed in three steps:

- Switch the ST7 to I²C mode. This is done by driving a specific signal sequence on the ICCCLK/DATA pins while the $\overline{\text{RESET}}$ pin is pulled low. When the ST7 enters I²C mode, it fetches a specific RESET vector which points to the ST7 system memory containing

the I²C protocol routine. This routine enables the ST7 to receive bytes from the I²C interface.

- Download ICP driver code in RAM from the ICCDATA pin
- Execute ICP driver code in RAM to program the FLASH memory

Depending on the ICP driver code downloaded in RAM, FLASH memory programming can be fully customized (number of bytes to program, program locations, or selection of the serial communication interface for downloading).

4.3.2 In application programming (IAP)

This mode uses an IAP driver program previously programmed in Sector 0 by the user (in ICP mode).

This mode is fully controlled by user software. This allows it to be adapted to the user application, (user-defined strategy for entering programming mode, choice of communications protocol used to fetch the data to be stored etc).

IAP mode can be used to program any memory areas except Sector 0, which is write/erase protected to allow recovery in case errors occur during the programming operation.

4.4 I²C interface

ICP needs a minimum of 4 and up to 6 pins to be connected to the programming tool. These pins are:

- $\overline{\text{RESET}}$: device reset
- V_{SS} : device power supply ground
- ICCCLK: I²C output serial clock pin
- ICCDATA: I²C input serial data pin
- CLKIN: main clock input for external source
- V_{DD} : application board power supply

Refer to [Figure 6](#) for a description of the I²C interface.

If the ICCCLK or ICCDATA pins are only used as outputs in the application, no signal isolation is necessary. As soon as the programming tool is plugged to the board, even if an I²C session is not in progress, the ICCCLK and ICCDATA pins are not available for the application. If they are used as inputs by the application, isolation such as a serial resistor has to be implemented in case another device forces the signal. Refer to the programming tool documentation for recommended resistor values.

During the ICP session, the programming tool must control the $\overline{\text{RESET}}$ pin. This can lead to conflicts between the programming tool and the application reset circuit if it drives more than 5 mA at high level (push pull output or pull-up resistor < 1 k Ω). A schottky diode can be used to isolate the application RESET circuit in this case. When using a classical RC network with $R > 1$ k Ω or a reset management IC with open drain output and pull-up resistor > 1 k Ω , no additional components are needed. In all cases the user must ensure that no external reset is generated by the application during the I²C session.

The use of Pin 7 of the I²C connector depends on the programming tool architecture. This pin must be connected when using most ST programming tools (it is used to monitor the application power supply). Please refer to the programming tool manual.

Pin 9 has to be connected to the CLKIN pin of the ST7 when I²C mode is selected with option bytes disabled (35-pulse I²C entry mode). When option bytes are enabled (38-pulse I²C entry mode), the internal RC clock (internal RC or AWU RC) is forced. If internal RC is selected in the option byte, the internal RC is provided. If AWU RC or external clock is selected, the AWU RC oscillator is provided.

A serial resistor must be connected to I²C connector pin 6 in order to prevent contention on PA3/RESET pin. Contention may occur if a tool forces a state on RESET pin while PA3 pin forces the opposite state in output mode. The resistor value is defined to limit the current below 2 mA at 5 V. If PA3 is used as output push-pull, then the application must be switched off to allow the tool to take control of the RESET pin (PA3). To allow the programming tool to drive the RESET pin below V_{IL}, special care must also be taken when a pull-up is placed on PA3 for application reasons.

Caution: During normal operation, ICCCLK pin must be pulled-up, internally or externally (external pull-up of 10 kΩ mandatory in noisy environment). This is to avoid entering I²C mode unexpectedly during a reset. In the application, even if the pin is configured as output, any reset will put it back in input pull-up.

Figure 6. Typical I²C interface

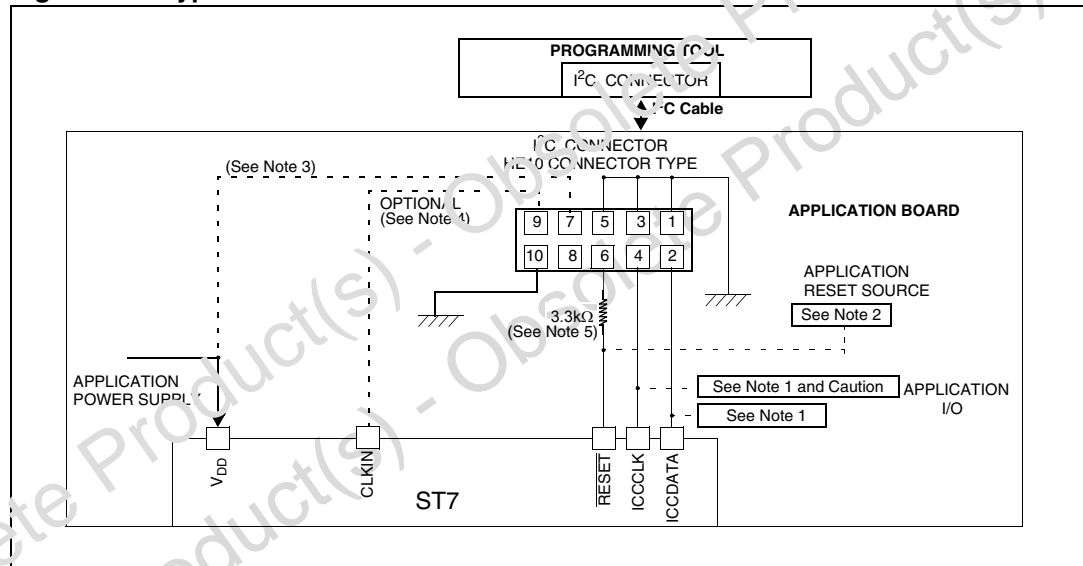

4.5 Memory protection

There are two different types of memory protection: readout protection and Write/Erase Protection which can be applied individually.

4.5.1 Readout protection

Readout protection, when selected provides a protection against program memory content extraction and against write access to Flash memory. Even if no protection can be considered as totally unbreakable, the feature provides a very high level of protection for a general purpose microcontroller. Program memory is protected.

In flash devices, this protection is removed by reprogramming the option. In this case, program memory is automatically erased, and the device can be reprogrammed.

Readout protection selection depends on the device type:

- In Flash devices it is enabled and removed through the FMP_R bit in the option byte.
- In ROM devices it is enabled by mask option specified in the option list.

4.5.2 Flash Write/Erase protection

Write/erase protection, when set, makes it impossible to both overwrite and erase program memory. Its purpose is to provide advanced security to applications and prevent any change being made to the memory content.

Warning: Once set, Write/erase protection can never be removed. A write-protected flash device is no longer reprogrammable.

Write/erase protection is enabled through the FMP_W bit in the option byte.

4.6 Related documentation

For details on Flash programming and I²C protocol, refer to the ST7 Flash programming reference manual and to the ST7 I²C protocol reference manual.

4.7 Register description

4.7.1 Flash Control/Status register (FCSR)

This register controls the XFlash erasing and programming using ICP, IAP or other programming methods.

1st RASS Key: 0101 0110 (56h)

2nd RASS Key: 1010 1110 (AEh)

When an EPB or another programming tool is used (in socket or ICP mode), the RASS keys are sent automatically.

Reset value: 000 0000 (00h)

7	0	0	0	0	0	OPT	AI	0	PGM
Read/write									

Table 4. FLASH register map and reset values

Address (Hex.)	Register Label	7	6	5	4	3	2	1	0
002Fh	FCSR Reset value	0	0	0	0	0	OPT 0	LAT 0	PGM 0

5 Central processing unit

5.1 Introduction

This CPU has a full 8-bit architecture and contains six internal registers allowing efficient 8-bit data manipulation.

5.2 Main features

- 63 basic instructions
- Fast 8-bit by 8-bit multiply
- 17 main addressing modes
- Two 8-bit index registers
- 16-bit stack pointer
- Low power modes
- Maskable hardware interrupts
- Non-maskable software interrupt

5.3 CPU registers

The six CPU registers shown in [Figure 7](#) are not present in the memory mapping and are accessed by specific instructions.

5.3.1 Accumulator (A)

The Accumulator is an 8-bit general purpose register used to hold operands and the results of the arithmetic and logic calculations and to manipulate data.

5.3.2 Index registers (X and Y)

In indexed addressing modes, these 8-bit registers are used to create either effective addresses or temporary storage areas for data manipulation. (The cross-assembler generates a precede instruction (PRE) to indicate that the following instruction refers to the Y register.)

The Y register is not affected by the interrupt automatic procedures (not pushed to and popped from the stack).

5.3.3 Program counter (PC)

The program counter is a 16-bit register containing the address of the next instruction to be executed by the CPU. It is made of two 8-bit registers PCL (program counter low which is the LSB) and PCH (program counter high which is the MSB).

Figure 7. CPU registers

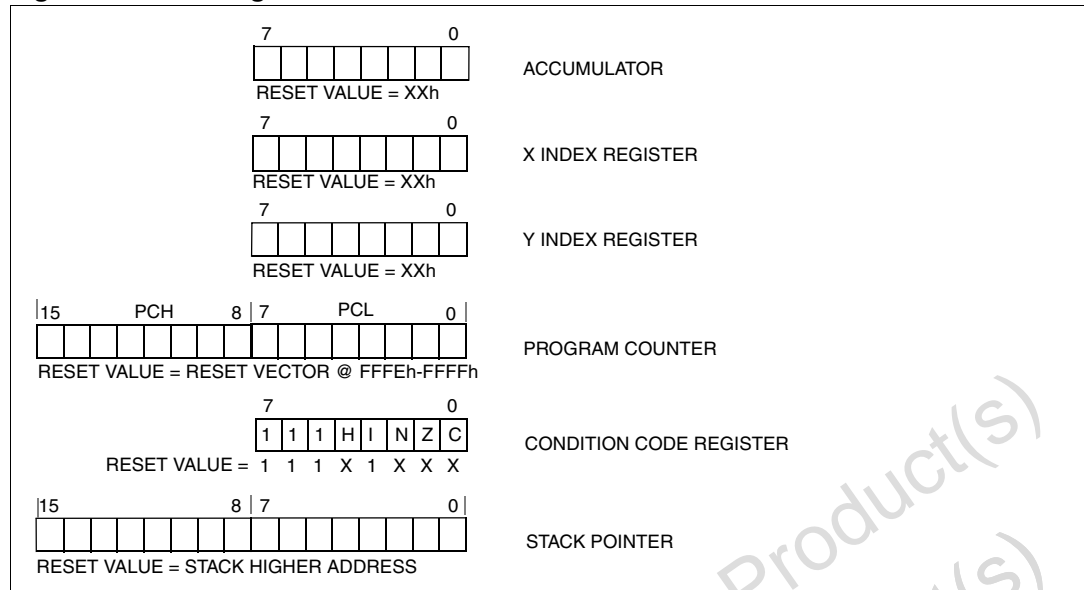

1. X = Undefined value

5.3.4 Condition Code register (CC)

The 8-bit Condition Code register contains the interrupt mask and four flags representative of the result of the instruction just executed. This register can also be handled by the PUSH and POP instructions.

These bits can be individually tested and/or controlled by specific instructions.

Reset value: 111x1xxx

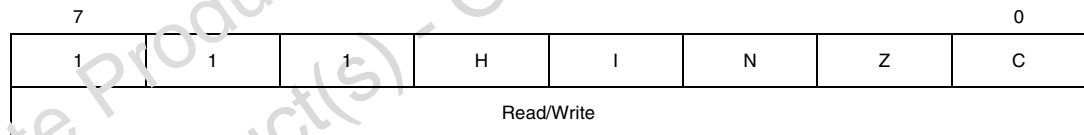

Bit 7:5 Set to '1'

Bit 4 **H** *Half carry*

This bit is set by hardware when a carry occurs between bits 3 and 4 of the ALU during an ADD or ADC instruction. It is reset by hardware during the same instructions.

0: No half carry has occurred.

1: A half carry has occurred.

This bit is tested using the JRH or JRNH instruction. The H bit is useful in BCD arithmetic subroutines.

Bit 3 **I** *Interrupt mask*

This bit is set by hardware when entering in interrupt or by software to disable all interrupts except the TRAP software interrupt. This bit is cleared by software.

0: Interrupts are enabled.

1: Interrupts are disabled.

This bit is controlled by the RIM, SIM and IRET instructions and is tested by the JRM and JRNH instructions.

Note: Interrupts requested while I is set are latched and can be processed when I is cleared. By default an interrupt routine is not interruptible because the I bit is set by hardware at the start of the routine and reset by the IRET instruction at the end of the routine. If the I bit is cleared by software in the interrupt routine, pending interrupts are serviced regardless of the priority level of the current interrupt routine.

Bit 2 **N** *Negative*

This bit is set and cleared by hardware. It is representative of the result sign of the last arithmetic, logical or data manipulation. It is a copy of the 7th bit of the result.

0: The result of the last operation is positive or null.

1: The result of the last operation is negative (that is, the most significant bit is a logic 1).

This bit is accessed by the JRMI and JRPL instructions.

Bit 1 **Z** *Zero*

This bit is set and cleared by hardware. This bit indicates that the result of the last arithmetic, logical or data manipulation is zero.

0: The result of the last operation is different from zero.

1: The result of the last operation is zero.

This bit is accessed by the JREQ and JRNE test instructions.

Bit 0 = **C** *Carry/borrow*

This bit is set and cleared by hardware and software. It indicates an overflow or an underflow has occurred during the last arithmetic operation.

0: No overflow or underflow has occurred.

1: An overflow or underflow has occurred.

This bit is driven by the SCF and RCF instructions and tested by the JRC and JRNC instructions. It is also affected by the "bit test and branch", shift and rotate instructions.

5.3.5 Stack Pointer (SP)

Reset value: 00 FFh

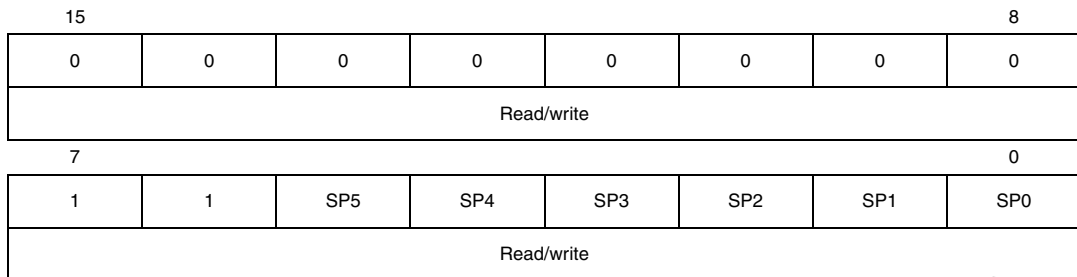

The Stack Pointer is a 16-bit register which is always pointing to the next free location in the stack. It is then decremented after data has been pushed onto the stack and incremented before data is popped from the stack (see [Figure 8](#)).

Since the stack is 64 bytes deep, the 10 most significant bits are forced by hardware. Following an MCU Reset, or after a Reset Stack Pointer instruction (RSP), the Stack Pointer contains its reset value (the SP5 to SP0 bits are set) which is the stack higher address.

The least significant byte of the Stack Pointer (called S) can be directly accessed by a LD instruction.

Note: When the lower limit is exceeded, the Stack Pointer wraps around to the stack upper limit, without indicating the stack overflow. The previously stored information is then overwritten and therefore lost. The stack also wraps in case of an underflow.

The stack is used to save the return address during a subroutine call and the CPU context during an interrupt. The user may also directly manipulate the stack by means of the PUSH and POP instructions. In the case of an interrupt, the PCL is stored at the first location pointed to by the SP. Then the other registers are stored in the next locations as shown in [Figure 8](#).

- When an interrupt is received, the SP is decremented and the context is pushed on the stack.
- On return from interrupt, the SP is incremented and the context is popped from the stack.

A subroutine call is located at two locations and an interrupt five locations in the stack area.

Figure 8. Stack manipulation example

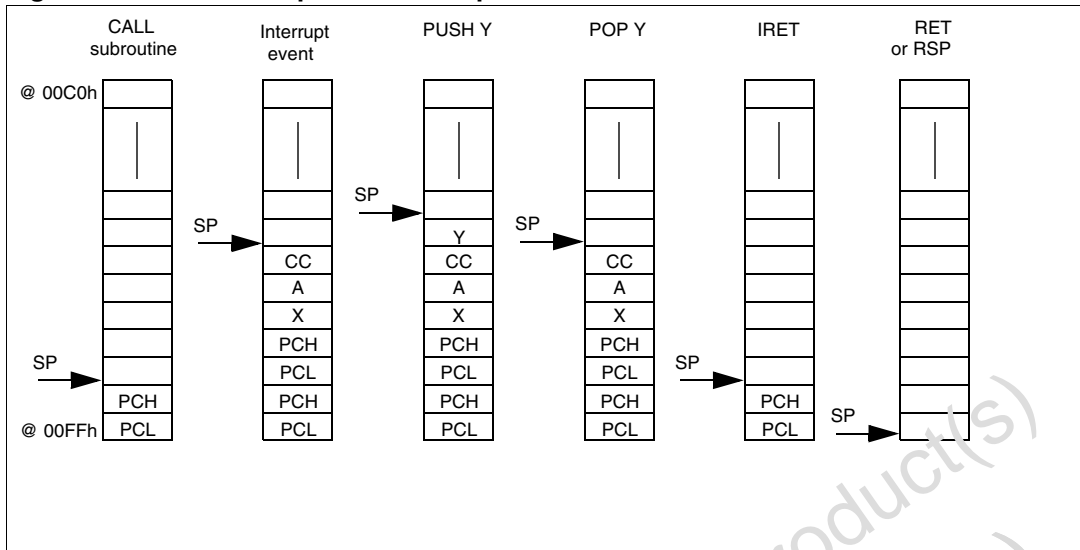

1. Stack higher address = 00FFh.
2. Stack lower address = 00C0h.

Obsolete Product(s) - Obsolete Product(s)
 Obsolete Product(s) - Obsolete Product(s)

6 Supply, reset and clock management

The device includes a range of utility features for securing the application in critical situations (for example in case of a power brown-out), and reducing the number of external components.

6.1 Main features

- Clock management
 - 8 MHz internal RC oscillator (enabled by option byte)
 - External clock Input (enabled by option byte)
- Reset sequence manager (RSM)
- System integrity management (SI)
 - Main supply low voltage detection (LVD) with reset generation (enabled by option byte)
 - Auxiliary voltage detector (AVD) with interrupt capability for monitoring the main supply

6.2 Internal RC oscillator adjustment

The ST7 contains an internal RC oscillator with a specific accuracy for a given device, temperature and voltage. It can be selected as the start up clock through the CKSEL[1:0] option bits (see [Section 14.1 on page 123](#)). It must be calibrated to obtain the frequency required in the application. This is done by software writing a 10-bit calibration value in the RCCR (RC Control register) and in the bits [6:5] in the SICSR (SI Control Status register).

Whenever the microcontroller is reset, the RCCR returns to its default value (FFh), i.e. each time the device is reset, the calibration value must be loaded in the RCCR. Predefined calibration values are stored in Flash memory for 3.3 and 5 V V_{DD} supply voltages at 25°C, as shown in the following table.

Table 5. Predefined RC oscillator calibration values

RCCR	Conditions	ST7LITEUS2/ST7LITEUS5 address
RCCR0	$V_{DD}=5\text{ V}$ $T_A=25\text{ °C}$ $f_{RC}=8\text{ MHz}$	DEE0h ⁽¹⁾ (CR[9:2] bits)
RCCRL0		DEE1h ⁽¹⁾ (CR[1:0] bits)
RCCR1	$V_{DD}=3.3\text{ V}$ $T_A=25\text{ °C}$ $f_{RC}=8\text{ MHz}$	DEE2h ⁽¹⁾ (CR[9:2] bits)
RCCRL1		DEE3h ⁽¹⁾ (CR[1:0] bits)

1. DEE0h, DEE1h, DEE2h and DEE3h are located in a reserved area but are special bytes containing also the RC calibration values which are read-accessible only in user mode. If all the Flash space (including the RC calibration value locations) has been erased (after the readout protection removal), then the RC calibration values can still be obtained through these two addresses.

- Note:**
- 1 In I²C mode, the internal RC oscillator is forced as a clock source, regardless of the selection in the option byte. Refer to note 5 in [Section 4.4 on page 19](#) for further details.
 - 2 See [Section 12: Electrical characteristics](#) for more information on the frequency and accuracy of the RC oscillator.
 - 3 To improve clock stability and frequency accuracy, it is recommended to place a decoupling capacitor, typically 100nF, between the V_{DD} and V_{SS} pins as close as possible to the ST7 device.

Caution: If the voltage or temperature conditions change in the application, the frequency may need to be recalibrated.

Refer to application note AN2326 for information on how to calibrate the RC frequency using an external reference signal.

The ST7LITEUS2 and ST7LITEUS5 also contain an Auto-wakeup RC oscillator. This RC oscillator should be enabled to enter Auto-wakeup from Halt mode.

The Auto-wakeup RC oscillator can also be configured as the startup clock through the CKSEL[1:0] option bits (see [Section 14.1 on page 123](#)).

This is recommended for applications where very low power consumption is required.

Switching from one startup clock to another can be done in run mode as follows (see [Figure 9](#)):

Case 1

Switching from internal RC to AWU:

1. Set the RC/AWU bit in the CKCNTCSR register to enable the AWU RC oscillator
2. The RC_FLAG is cleared and the clock output is at 1.
3. Wait 3 AWU RC cycles till the AWU_FLAG is set
4. The switch to the AWU clock is made at the positive edge of the AWU clock signal
5. Once the switch is made, the internal RC is stopped

Case 2

Switching from AWU RC to internal RC:

1. Reset the RC/AWU bit to enable the internal RC oscillator
2. Using a 4-bit counter, wait until 8 internal RC cycles have elapsed. The counter is running on internal RC clock.
3. Wait till the AWU_FLAG is cleared (1AWU RC cycle) and the RC_FLAG is set (2 RC cycles)
4. The switch to the internal RC clock is made at the positive edge of the internal RC clock signal
5. Once the switch is made, the AWU RC is stopped

- Note:**
- 1 When the internal RC is not selected, it is stopped so as to save power consumption.
 - 2 When the internal RC is selected, the AWU RC is turned on by hardware when entering Auto-wakeup from Halt mode.
 - 3 When the external clock is selected, the AWU RC oscillator is always on.

Figure 9. Clock switching

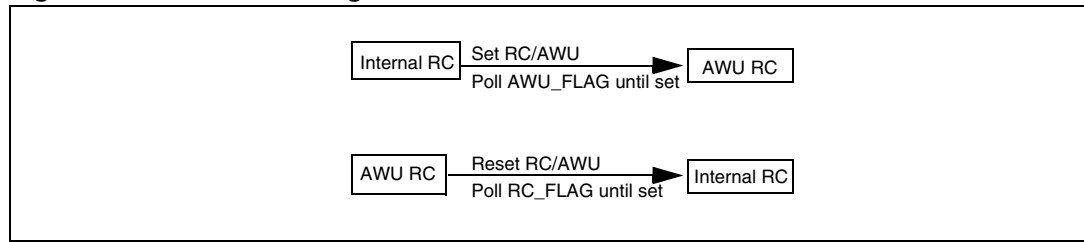

6.3 Register description

6.3.1 Main Clock Control/Status register (MCCSR)

Reset value: 0000 0000 (00h)

7							0
0	0	0	0	0	0	0	MCO SMS
Read / Write							

Bits 7:2 Reserved, must be kept cleared.

Bit 1 **MCO** Main Clock Out enable bit

This bit is read/write by software and cleared by hardware after a reset. This bit allows to enable the MCO output clock.

0: MCO clock disabled, I/O port free for general purpose I/O.

1: MCO clock enabled.

Bit 0 **SMS** Slow Mode select

This bit is read/write by software and cleared by hardware after a reset. This bit selects the input clock f_{OSC} or $f_{OSC}/32$.

0: Normal mode ($f_{CPU} = f_{OSC}$)

1: Slow mode ($f_{CPU} = f_{OSC}/32$)

6.3.2 RC Control register (RCCR)

Reset value: 1111 1111 (FFh)

7							0
CR9	CR8	CR7	CR6	CR5	CR4	CR3	CR2
Read / Write							

Bits 7:0 CR[9:2] RC Oscillator Frequency Adjustment Bits

These bits, as well as CR[1:0] bits in the SICSR register must be written immediately after reset to adjust the RC oscillator frequency and to obtain the required accuracy. The application can store the correct value for each voltage range in Flash memory and write it to this register at startup.

00h = maximum available frequency

FFh = lowest available frequency

Note: To tune the oscillator, write a series of different values in the register until the correct frequency is reached. The fastest method is to use a dichotomy starting with 80h.

6.3.3 System Integrity (SI) Control/status register (SICSR)

Reset value: 0000 0x00 (0xh)

7							0
0	CR1	CR0	0	0	LVDRF	AVDF	AVDIE
Read / Write							

Bit 7 Reserved, must be kept cleared.

Bits 6:5 CR[1:0] RC Oscillator Frequency Adjustment bits

These bits, as well as CR[9:2] bits in the RCCR register must be written immediately after reset to adjust the RC oscillator frequency and to obtain the required accuracy. Refer to [Section 6.2 on page 28](#).

Bits 4:3 Reserved, must be kept cleared.

Bits 2:0 System Integrity bits. Refer to [Section 7.4 on page 43](#).

6.3.4 AVD Threshold Selection register (AVDTHCR)

Reset value: 0000 0011 (03h)

7	0
CK2	AVD0
CK1	AVD1
CK0	0
0	0
0	0
Read / Write	

Bits 7:5 **CK[2:0]** Internal RC Prescaler Selection
 These bits are set by software and cleared by hardware after a reset. These bits select the prescaler of the internal RC oscillator. See [Figure 10 on page 34](#) and [Table 6](#).

Bits 4:2 Reserved, must be kept cleared.

Bits 1:0 AVD Threshold Selection bits. Refer to [Section 7.4: System integrity management \(SI\)](#).

Table 6. Internal RC prescaler selection bits⁽¹⁾

CK2	CK1	CK0	f _{osc}
0	0	0	f _{RC}
0	0	1	f _{RC/2}
0	1	0	f _{RC/4}
0	1	1	f _{RC/8}
1	0	0	f _{RC/16}

1. If the internal RC is used with a supply operating range below 3.3 V, a division ratio of at least 2 must be enabled in the RC prescaler.

6.3.5 Clock Controller Control/Status register (CKCNTCSR)

Read/Write

Reset value: 0000 1001 (09h)

7	0
0	RC/AWU
0	0
0	RC_FLAG
0	AWU_FLAG
0	0
Read / Write	

Bits 7:4 Reserved, must be kept cleared.

Bit 3 **AWU_FLAG** AWU Selection
 This bit is set and cleared by hardware
 0: No switch from AWU to RC requested
 1: AWU clock activated and temporization completed

Bit 2 **RC_FLAG** *RC Selection*
 This bit is set and cleared by hardware
 0: No switch from RC to AWU requested
 1: RC clock activated and temporization completed

Bit 1 = Reserved, must be kept cleared.

Bit 0 = **RC/AWU** *RC/AWU Selection*
 0: RC enabled
 1: AWU enabled (default value)

Table 7. Clock register map and reset values

Address (Hex.)	Register label	7	6	5	4	3	2	1	0
0038h	MCCSR Reset value	0	0	0	0	0	0	MCO 0	SMS 0
0039h	RCCR reset value	CR9 1	CR8 1	CR7 1	CR6 1	CR5 1	CF4 1	CR3 1	CR2 1
003Ah	SICSR reset value	0	CR1	CR0	0	0	LVDRF x	AVDF 0	AVDIE 0
003Eh	AVDTHCR reset value	CK2 0	CK1 0	CK0 0	0	0	0	AVD1 1	AVD2 1
003Fh	CKCNTCSR reset value	0	0	0	0	AWU_FLAG 1	RC_FLAG 0	0	RC/AWU 1

Figure 10. Clock management block diagram

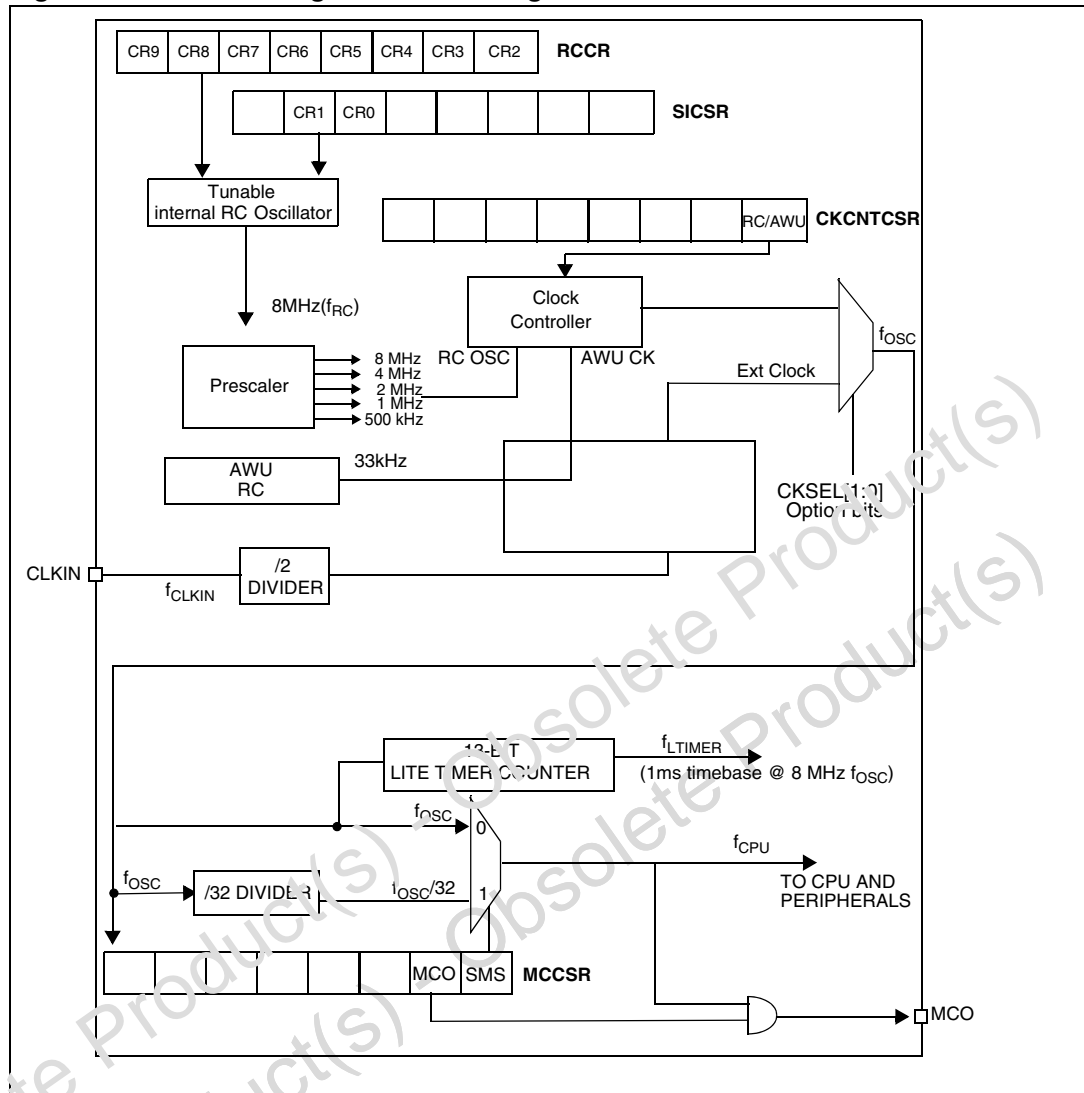

6.4 Reset sequence manager (RSM)

6.4.1 Introduction

The reset sequence manager includes three reset sources as shown in [Figure 12](#):

- External $\overline{\text{RESET}}$ source pulse
- Internal LVD reset (low voltage detection)
- Internal WATCHDOG reset

Note: A reset can also be triggered following the detection of an illegal opcode or prebyte code. Refer to [Figure 12](#).

These sources act on the $\overline{\text{RESET}}$ pin and it is always kept low during the delay phase.

The RESET service routine vector is fixed at addresses FFFEh-FFFFh in the ST7 memory map.

The basic reset sequence consists of 3 phases as shown in [Figure 11](#):

- Active phase depending on the reset source
- 64 CPU clock cycle delay
- RESET vector fetch

Caution: When the ST7 is unprogrammed or fully erased, the Flash is blank and the RESET vector is not programmed. For this reason, it is recommended to keep the $\overline{\text{RESET}}$ pin in low state until programming mode is entered, in order to avoid unwanted behavior.

The 64 CPU clock cycle delay allows the oscillator to stabilise and ensures that recovery has taken place from the Reset state.

The RESET vector fetch phase duration is 2 clock cycles.

Figure 11. Reset sequence phases

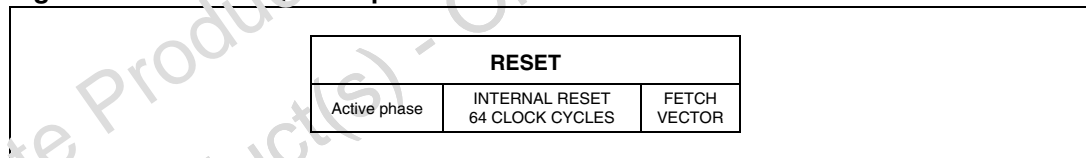
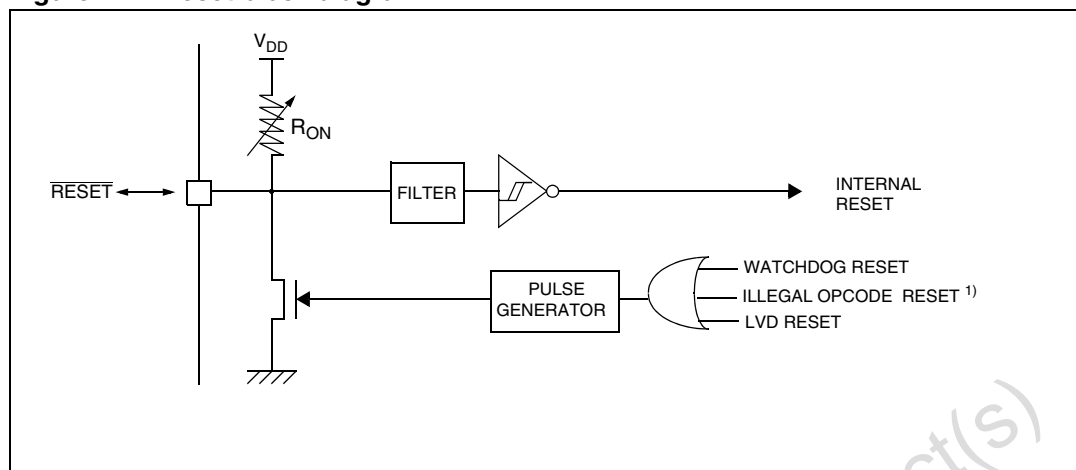

Figure 12. Reset block diagram



1. [Section 11.2.1: Illegal opcode reset](#) for more details on illegal opcode reset conditions.

6.4.2 Asynchronous external RESE̅T pin

The RESE̅T pin is both an input and an open-drain output with integrated R_{ON} weak pull-up resistor. This pull-up has no fixed value but varies in accordance with the input voltage. It can be pulled low by external circuitry to reset the device. See Electrical Characteristic section for more details.

A RESE̅T signal originating from an external source must have a duration of at least $t_{h(RSTL)in}$ in order to be recognized (see [Figure 13](#)). This detection is asynchronous and therefore the MCU can enter reset state even in Halt mode.

The RESE̅T pin is an asynchronous signal which plays a major role in EMS performance. In a noisy environment, it is recommended to follow the guidelines mentioned in the electrical characteristics section.

6.4.3 External Power-on reset

If the LVD is disabled by option byte, to start up the microcontroller correctly, the user must ensure by means of an external reset circuit that the reset signal is held low until V_{DD} is over the minimum level specified for the selected f_{CLKIN} frequency.

A proper reset signal for a slow rising V_{DD} supply can generally be provided by an external RC network connected to the RESE̅T pin.

6.4.4 Internal low voltage detector (LVD) reset

Two different reset sequences caused by the internal LVD circuitry can be distinguished:

- Power-on reset
- Voltage Drop reset

The device RESE̅T pin acts as an output that is pulled low when $V_{DD} < V_{IT+}$ (rising edge) or $V_{DD} < V_{IT-}$ (falling edge) as shown in [Figure 13](#).

The LVD filters spikes on V_{DD} larger than $t_{g(VDD)}$ to avoid parasitic resets.

6.4.5 Internal watchdog reset

The reset sequence generated by a internal watchdog counter overflow is shown in [Figure 13](#).

Starting from the watchdog counter underflow, the device $\overline{\text{RESET}}$ pin acts as an output that is pulled low during at least $t_{w(\text{RSTL})\text{out}}$.

Figure 13. Reset sequences

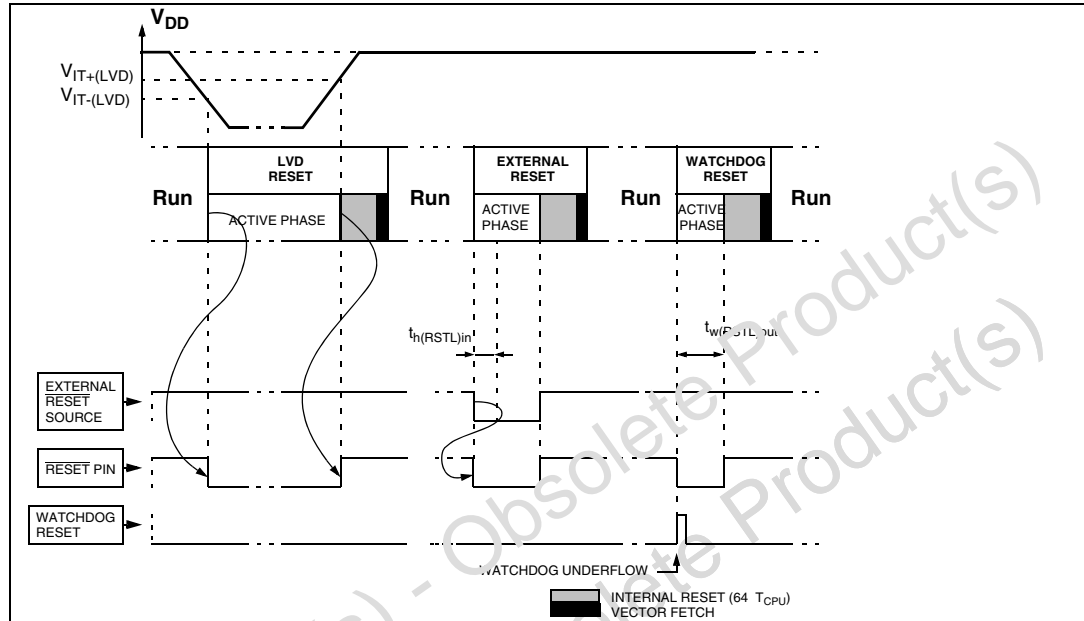

6.5 Register description

6.5.1 Multiplexed I/O Reset Control register 1 (MUXCR1)

Reset value: 0000 0000 (00h)

7	0						
MIR15	MIR14	MIR13	MIR12	MIR11	MIR10	MIR9	MIR8
Read / Write once							

6.5.2 Multiplexed I/O Reset Control register 0 (MUXCR0)

Reset value: 0000 0000 (00h)

7	0						
MIR7	MIR6	MIR5	MIR4	MIR3	MIR2	MIR1	MIR0
Read / Write once							

Bits 15:0 **MIR[15:0]**

This 16-bit register is read/write by software but can be written only once between two reset events. It is cleared by hardware after a reset; When both MUXCR0 and MUXCR1 registers are at 00h, the multiplexed PA3/ $\overline{\text{RESET}}$ pin will act as $\overline{\text{RESET}}$. To configure this pin as output (Port A3), write 55h to MUXCR0 and AAh to MUXCR1.

These registers are one-time writable only.

- To configure PA3 as general purpose output:
After power-on / reset, the application program has to configure the I/O port by writing to these registers as described above. Once the pin is configured as an I/O output, it cannot be changed back to a reset pin by the application code.
- To configure PA3 as $\overline{\text{RESET}}$:
An internally generated reset (such as POR, LVD, WDG, illegal opcode) will clear the two registers and the pin will act again as a reset function. Otherwise, a power-down is required to put the pin back in reset configuration.

Table 8. Multiplexed IO register map and reset values

Address (Hex.)	Register label	7	6	5	4	3	2	1	0
0047h	MUXCR0 reset value	MIR7 0	MIR6 0	MIR5 0	MIR4 0	MIR3 0	MIR2 0	MIR1 0	MIR0 0
0048h	MUXCR1 reset value	MIR15 0	MIR14 0	MIR13 0	MIR12 0	MIR11 0	MIR10 0	MIR9 0	MIR8 0

7 Interrupts

The ST7 core may be interrupted by one of two different methods: Maskable hardware interrupts as listed in the “interrupt mapping” table and a non-maskable software interrupt (TRAP). The Interrupt processing flowchart is shown in [Figure 14](#).

The maskable interrupts must be enabled by clearing the I bit in order to be serviced. However, disabled interrupts may be latched and processed when they are enabled (see external interrupts subsection).

Note: After reset, all interrupts are disabled.

When an interrupt has to be serviced:

- Normal processing is suspended at the end of the current instruction execution.
- The PC, X, A and CC registers are saved onto the stack.
- The I bit of the CC register is set to prevent additional interrupts.
- The PC is then loaded with the interrupt vector of the interrupt to service and the first instruction of the interrupt service routine is fetched (refer to the Interrupt Mapping table for vector addresses).

The interrupt service routine should finish with the IRET instruction which causes the contents of the saved registers to be recovered from the stack.

Note: As a consequence of the IRET instruction, the I bit is cleared and the main program resumes.

Priority management

By default, a servicing interrupt cannot be interrupted because the I bit is set by hardware entering in interrupt routine.

In the case when several interrupts are simultaneously pending, an hardware priority defines which one will be serviced first (see [Table 9: Interrupt mapping](#)).

Interrupts and low power mode

All interrupts allow the processor to leave the Wait low power mode. Only external and specifically mentioned interrupts allow the processor to leave the Halt low power mode (refer to the “Exit from Halt” column in [Table 9: Interrupt mapping](#)).

7.1 Non maskable software interrupt

This interrupt is entered when the TRAP instruction is executed regardless of the state of the I bit. It is serviced according to the flowchart in [Figure 14](#).

7.2 External interrupts

External interrupt vectors can be loaded into the PC register if the corresponding external interrupt occurred and if the I bit is cleared. These interrupts allow the processor to leave the Halt low power mode.

The external interrupt polarity is selected through the miscellaneous register or interrupt register (if available).

An external interrupt triggered on edge will be latched and the interrupt request automatically cleared upon entering the interrupt service routine.

Caution: The type of sensitivity defined in the Miscellaneous or Interrupt register (if available) applies to the ei source. In case of a Nanded source (as described in the I/O ports section), a low level on an I/O pin, configured as input with interrupt, masks the interrupt request even in case of rising-edge sensitivity.

7.3 Peripheral interrupts

Different peripheral interrupt flags in the status register are able to cause an interrupt when they are active if both:

- The I bit of the CC register is cleared.
- The corresponding enable bit is set in the control register.

If any of these two conditions is false, the interrupt is latched and thus remains pending.

Clearing an interrupt request is done by:

- Writing "0" to the corresponding bit in the status register or
- Access to the status register while the flag is set followed by a read or write of an associated register.

Note: The clearing sequence resets the internal latch. A pending interrupt (that is, waiting for being enabled) will therefore be lost if the clear sequence is executed.

Figure 14. Interrupt processing flowchart

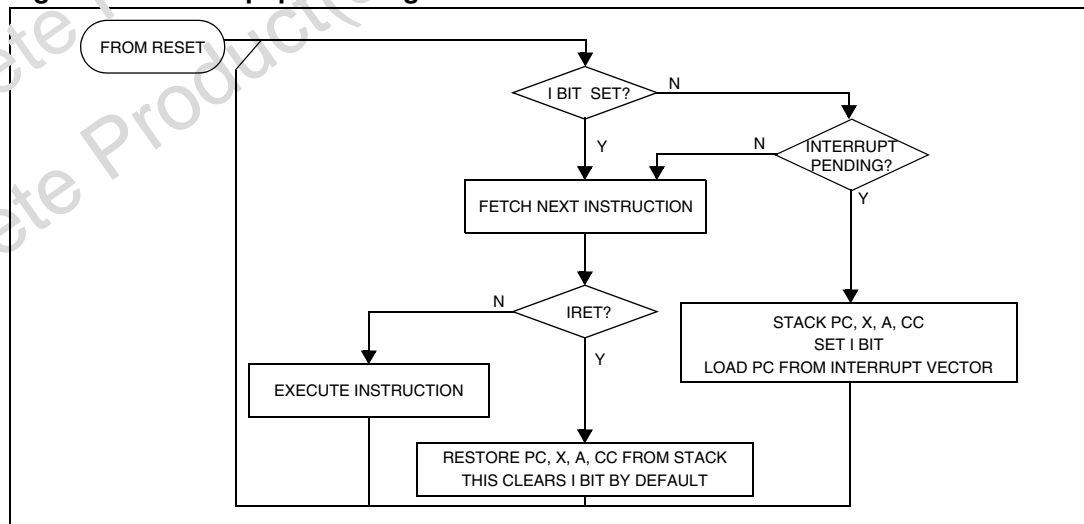

Table 9. Interrupt mapping

N°	Source block	Description	Register label	Priority order	Exit from Halt	Address vector
	RESET	Reset	N/A	Highest priority ↓ Lowest priority	yes	FFFEh-FFFFh
	TRAP	Software interrupt			no	FFFCh-FFFDh
0	AWU	Auto-wakeup interrupt	AWUCSR		yes ⁽¹⁾	FFFAh-FFFBh
1	ei0	External interrupt 0	N/A		yes	FFF8h-FFF9h
2	ei1	External interrupt 1				FFF6h-FFF7h
3	ei2	External interrupt 2				FFF4h-FFF5h
4		Not used			no	FFF2h-FFF3h
5	ei3	External interrupt 3			yes	FFF0h-FFF1h
6 ⁽²⁾	ei4 ⁽²⁾	External interrupt 4 ⁽²⁾			no ⁽²⁾	FFEEh-FFEFh
7	SI	AVD interrupt	SICSR		no	FFECh-FFEDh
8	AT TIMER	AT TIMER Output Compare Interrupt	PWMxCSR or ATCSR		no	FFEAh-FFEBh
9		AT TIMER Overflow Interrupt	ATCSR		yes ⁽³⁾	FFE8h-FFE9h
10	LITE TIMER	LITE TIMER Input Capture Interrupt	LTCSR		no	FFE6h-FFE7h
11		LITE TIMER RTC1 Interrupt	LTCSR	yes ⁽³⁾	FFE4h-FFE5h	
12		Not used		no	FFE2h-FFE3h	
13		Not used		no	FFE0h-FFE1h	

1. This interrupt exits the MCU from Auto-wakeup from Halt mode only.
2. This interrupt exits the MCU from Wait and Active-halt modes only. Moreover, IS4[1:0] = 01 is the only safe configuration to avoid spurious interrupt in Halt and AWUFH mode
3. These interrupts exit the MCU from Active-halt mode only.

7.3.1 External Interrupt Control register 1 (EICR1)

Reset value: 0000 0000 (00h)

7	0	0	IS21	IS20	IS11	IS10	IS01	IS00	0
Read/Write									

Bits 7:6 Reserved

Bits 5:4 **IS2[1:0]** *ei2 sensitivity*

These bits define the interrupt sensitivity for ei2 according to [Table 10](#).

Bits 3:2 **IS1[1:0]** *ei1 sensitivity*

These bits define the interrupt sensitivity for ei1 according to [Table 10](#).

Bits 1:0 **IS0[1:0]** *ei0 sensitivity*

These bits define the interrupt sensitivity for ei0 according to [Table 10](#).

- Note:
- 1 These 8 bits can be written only when the I bit in the CC register is set.
 - 2 Changing the sensitivity of a particular external interrupt clears this pending interrupt. This can be used to clear unwanted pending interrupts. Refer to [Section : External interrupt function](#).

7.3.2 External Interrupt Control register 2 (EICR2)

Reset value: 0000 0000 (00h)

7							0
0	0	0	0	IS41	IS40	IS31	IS30
Read/Write							

Bits 7:4 Reserved

Bits 3:2 **IS4[1:0]** ei4 sensitivity

These bits define the interrupt sensitivity for ei1 according to [Table 10](#).

Bits 1:0 **IS3[1:0]** ei3 sensitivity

These bits define the interrupt sensitivity for ei0 according to [Table 10](#).

- Note:
- 1 These 8 bits can be written only when the I bit in the CC register is set.
 - 2 Changing the sensitivity of a particular external interrupt clears this pending interrupt. This can be used to clear unwanted pending interrupts. Refer to [Section : External interrupt function](#).
 - 3 $IS4[1:0] = 01$ is the only safe configuration to avoid spurious interrupt in Halt and AWUFH modes.

Table 10. Interrupt sensitivity bits

ISx1	ISx0	External interrupt sensitivity
0	0	Falling edge & low level
0	1	Rising edge only
1	0	Falling edge only
1	1	Rising and falling edge

7.4 System integrity management (SI)

The System Integrity Management block contains the low voltage detector (LVD) and Auxiliary Voltage Detector (AVD) functions. It is managed by the SICSR register.

Note: A reset can also be triggered following the detection of an illegal opcode or prebyte code. Refer to [Section 11.2.1: Illegal opcode reset](#) for further details.

7.4.1 Low voltage detector (LVD)

The low voltage detector function (LVD) generates a static reset when the V_{DD} supply voltage is below a $V_{IT-(LVD)}$ reference value. This means that it secures the power-up as well as the power-down keeping the ST7 in reset.

The $V_{IT-(LVD)}$ reference value for a voltage drop is lower than the $V_{IT+(LVD)}$ reference value for power-on in order to avoid a parasitic reset when the MCU starts running and sinks current on the supply (hysteresis).

The LVD Reset circuitry generates a reset when V_{DD} is below:

- $V_{IT+(LVD)}$ when V_{DD} is rising
- $V_{IT-(LVD)}$ when V_{DD} is falling

The LVD function is illustrated in [Figure 15](#).

The voltage threshold can be configured by option bytes to be low, medium or high. See [Section 14.1: Option bytes](#).

Provided the minimum V_{DD} value (guaranteed for the oscillator frequency) is above $V_{IT-(LVD)}$, the MCU can only be in two modes:

- Under full software control
- In static safe reset

In these conditions, secure operation is always ensured for the application without the need for external reset hardware.

During a low voltage detector reset, the $\overline{\text{RESET}}$ pin is held low, thus permitting the MCU to reset other devices.

Note: Use of LVD with capacitive power supply: with this type of power supply, if power cuts occur in the application, it is recommended to pull V_{DD} down to 0V to ensure optimum restart conditions. Refer to circuit example in [Figure 62](#) and note 4.

The LVD is an optional function which can be selected by option byte. See [Section 14.1 on page 123](#). It allows the device to be used without any external RESET circuitry. If the LVD is disabled, an external circuitry must be used to ensure a proper Power-on reset.

It is recommended to make sure that the V_{DD} supply voltage rises monotonously when the device is exiting from Reset, to ensure the application functions properly.

Make sure the right combination of LVD and AVD thresholds is used as LVD and AVD levels are not correlated. Refer to [Table 47 on page 95](#) and [Table 48 on page 96](#) for more details.

Caution: If an LVD reset occurs after a watchdog reset has occurred, the LVD will take priority and will clear the watchdog flag.

Figure 15. Low voltage detector vs reset

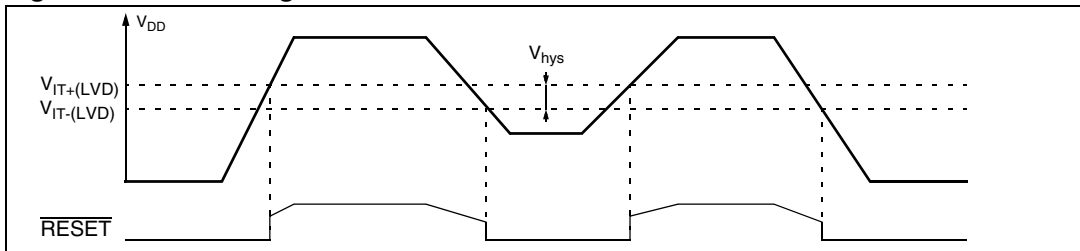
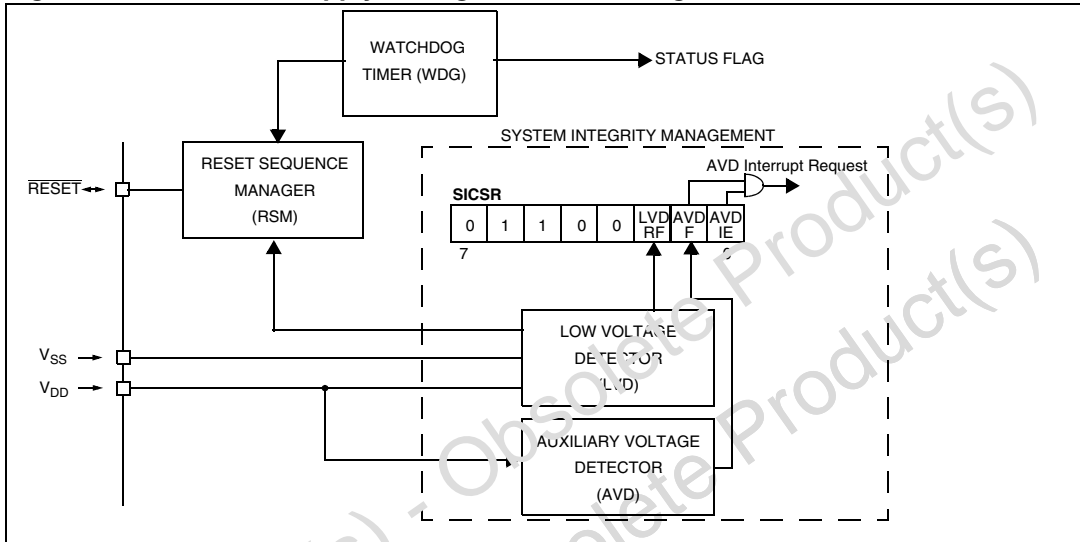

Figure 16. Reset and supply management block diagram



7.4.2 Auxiliary voltage detector (AVD)

The voltage detector function (AVD) is based on an analog comparison between a $V_{IT-(AVD)}$ and $V_{IT+(AVD)}$ reference value and the V_{DD} main supply voltage (V_{AVD}). The $V_{IT-(AVD)}$ reference value for falling voltage is lower than the $V_{IT+(AVD)}$ reference value for rising voltage in order to avoid parasitic detection (hysteresis).

The output of the AVD comparator is directly readable by the application software through a real time status bit (AVDF) in the SICSR register. This bit is read only.

Monitoring the V_{DD} main supply

The AVD threshold is selected by the AVD[1:0] bits in the AVDTHCR register.

If the AVD interrupt is enabled, an interrupt is generated when the voltage crosses the $V_{IT+(AVD)}$ or $V_{IT-(AVD)}$ threshold (AVDF bit is set).

In the case of a drop in voltage, the AVD interrupt acts as an early warning, allowing software to shut down safely before the LVD resets the microcontroller. See [Figure 17](#).

The interrupt on the rising edge is used to inform the application that the V_{DD} warning state is over

Note: Make sure the right combination of LVD and AVD thresholds is used as LVD and AVD levels are not correlated. Refer to [Table 47 on page 95](#) and [Table 48 on page 96](#) for more details.

Figure 17. Using the AVD to monitor V_{DD}

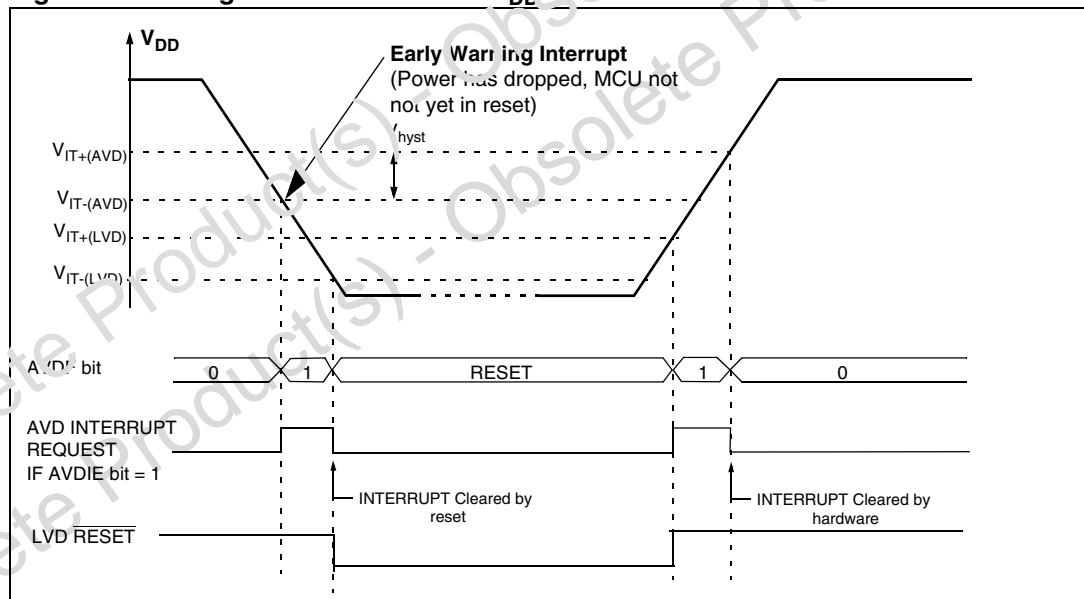

7.4.3 Low power modes

Table 11. Description of low power modes

Mode	Description
Wait	No effect on SI. AVD interrupts cause the device to exit from Wait mode.
Halt	The SICSR register is frozen. The AVD remains active but the AVD interrupt cannot be used to exit from Halt mode.

Interrupts

The AVD interrupt event generates an interrupt if the corresponding Enable Control Bit (AVDIE) is set and the interrupt mask in the CC register is reset (RIM instruction).

Table 12. Description of interrupt events

Interrupt Event	Event flag	Enable control bit	Exit from Wait	Exit from Halt
AVD event	AVDF	AVDIE	Yes	No

7.4.4 Register description

System Integrity (SI) Control/Status register (SICSR)

Reset value: 0000 0x00 (0xh)

7							0
0	CR1	CR0	0	0	LVDRF	AVDF	AVDIE
Read/write							

Bit 7 Reserved, must be kept cleared.

Bits 6:5 **CR[1:0]** RC Oscillator Frequency Adjustment bits

These bits, as well as CR[9:2] bits in the RCCR register must be written immediately after reset to adjust the RC oscillator frequency and to obtain the required accuracy. Refer to [Section 6.2: Internal RC oscillator adjustment on page 28](#).

Bits 4:3 Reserved, must be kept cleared.

Bit 2 LVDRF LVD reset flag

This bit indicates that the last Reset was generated by the LVD block. It is set by hardware (LVD reset) and cleared when read. See WDGRF flag description in [Section 10.1.6 on page 69](#) for more details. When the LVD is disabled by OPTION BYTE, the LVDRF bit value is undefined.

Note: If the selected clock source is one of the two internal ones, and if V_{DD} remains below the selected LVD threshold during less than T_{AWU} (33us typ.), the LVDRF flag cannot be set even if the device is reset by the LVD. If the selected clock source is the external clock (CLKIN), the flag is never set if the reset occurs during Halt mode. In run mode the flag is set only if f_{CLKIN} is greater than 10 MHz.

Bit 1 AVDF Voltage Detector flag

This read-only bit is set and cleared by hardware. If the AVDIE bit is set, an interrupt request is generated when the AVDF bit is set. Refer to [Figure 17](#) for additional details

0: V_{DD} over AVD threshold
 1: V_{DD} under AVD threshold

Bit 0 AVDIE Voltage Detector interrupt enable

This bit is set and cleared by software. It enables an interrupt to be generated when the AVDF flag is set. The pending interrupt information is automatically cleared when software enters the AVD interrupt routine.

0: AVD interrupt disabled
 1: AVD interrupt enabled

AVD Threshold Selection register (AVDTHCR)

Refer to [Section 6.3.4: AVD Threshold Selection register \(AVDTHCR\)](#) for a full description of this register.

Application notes

The LVDRF flag is not cleared when another reset type occurs (external or watchdog), the LVDRF flag remains set to keep trace of the original failure. In this case, a watchdog reset can be detected by software while an external reset can not.

Table 13. System integrity register map and reset values

Address (Hex.)	Register label	7	6	5	4	3	2	1	0
003Ah	SICSR reset value	0	1	1	0	0	LVDRF x	AVDF 0	AVDIE 0
003Eh	AVDTHCR reset value	CK2 0	CK1 0	CK0 0	0	0	0	AVD1 1	AVD2 1

8 Power saving modes

8.1 Introduction

To give a large measure of flexibility to the application in terms of power consumption, four main power saving modes are implemented in the ST7 (see [Figure 18](#)):

- Slow
- Wait (and Slow-wait)
- Active-halt
- Auto-wakeup from Halt (AWUFH)
- Halt

After a reset the normal operating mode is selected by default (Run mode). This mode drives the device (CPU and embedded peripherals) by means of a master clock which is based on the main oscillator frequency (f_{OSC}).

From Run mode, the different power saving modes may be selected by setting the relevant register bits or by calling the specific ST7 software instruction, whose action depends on the oscillator status.

Figure 18. Power saving mode transitions

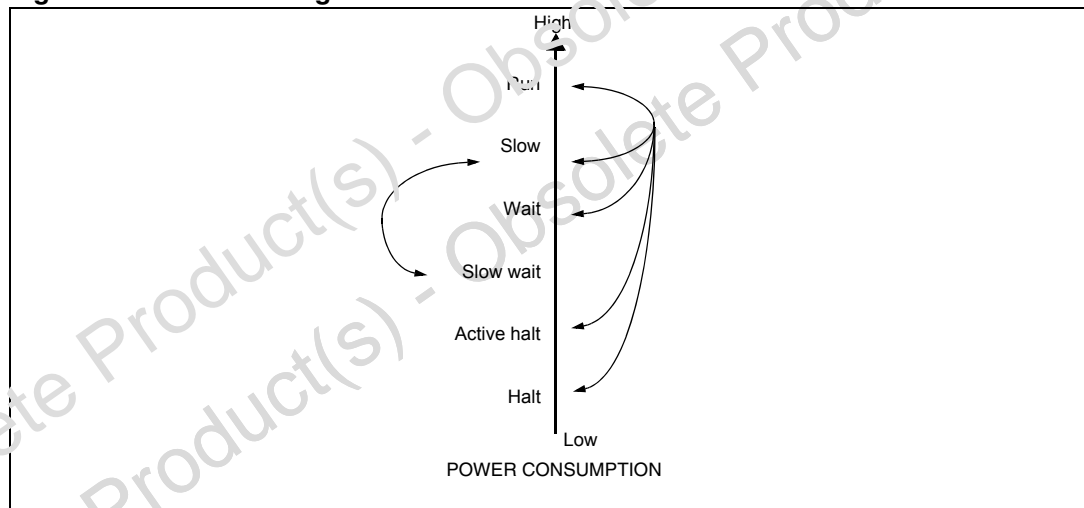

8.2 Slow mode

This mode has two targets:

- To reduce power consumption by decreasing the internal clock in the device,
- To adapt the internal clock frequency (f_{CPU}) to the available supply voltage.

Slow mode is controlled by the SMS bit in the MCCR register which enables or disables Slow mode.

In this mode, the oscillator frequency is divided by 32. The CPU and peripherals are clocked at this lower frequency.

Note: Slow-wait mode is activated when entering Wait mode while the device is already in Slow mode.

Figure 19. Slow mode clock transition

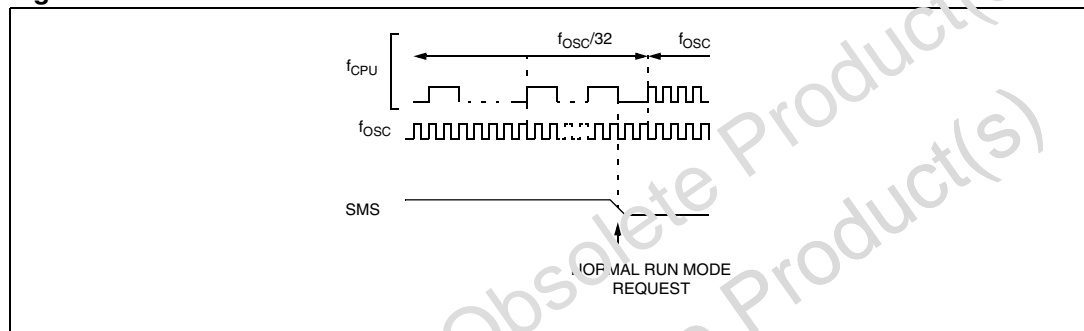

8.3 Wait mode

Wait mode places the MCU in a low power consumption mode by stopping the CPU.

This power saving mode is selected by calling the 'WFI' instruction.

All peripherals remain active. During Wait mode, the I bit of the CC register is cleared, to enable all interrupts. All other registers and memory remain unchanged. The MCU remains in Wait mode until an interrupt or reset occurs, whereupon the Program Counter branches to the starting address of the interrupt or Reset service routine.

The MCU will remain in Wait mode until a Reset or an Interrupt occurs, causing it to wakeup.

Refer to [Figure 20](#) for a description of the Wait mode flowchart.

Figure 20. Wait mode flowchart

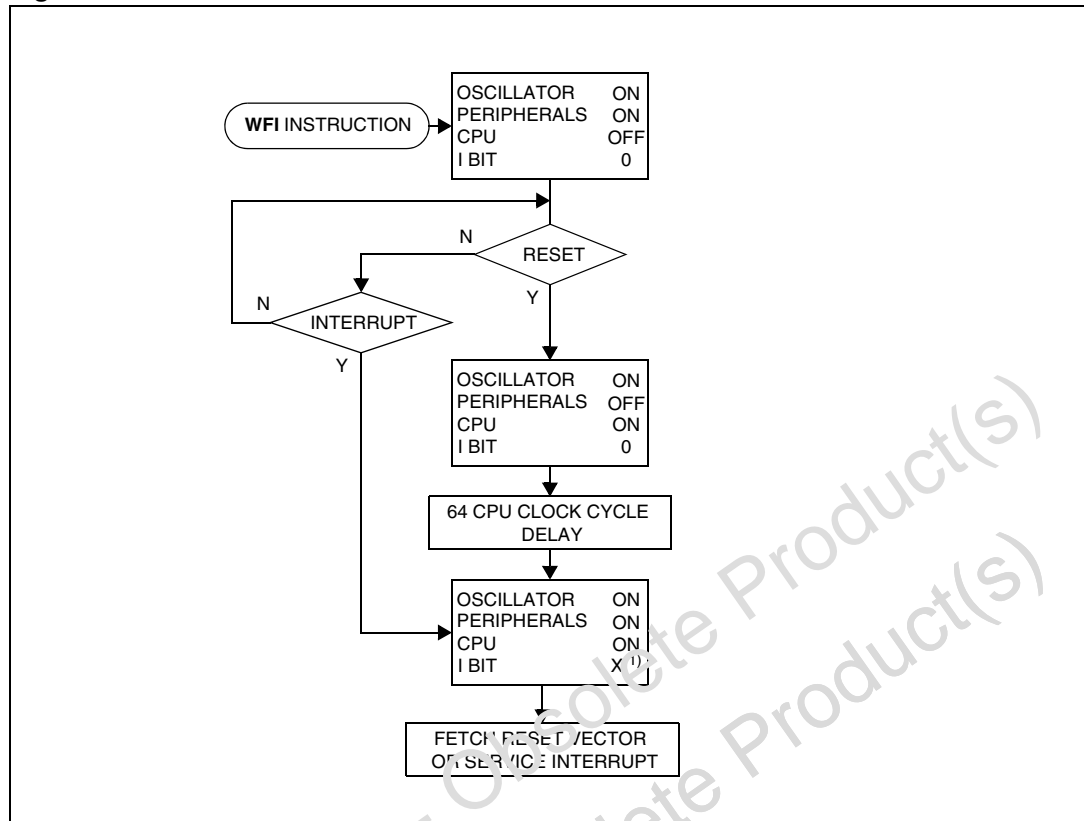

1. Before servicing an interrupt, the CC register is pushed on the stack. The I bit of the CC register is set during the interrupt routine and cleared when the CC register is popped.

8.4 Active-halt and Halt modes

Active-halt and Halt modes are the two lowest power consumption modes of the MCU. They are both entered by executing the 'HALT' instruction. The decision to enter either in Active-halt or Halt mode is given by the LTCSR/ATCSR register status as shown in the following table:

Table 14. Enabling/disabling Active-halt and Halt modes

LTCSR TBIE bit	ATCSR OVFIE bit	ATCSRCK1 bit	ATCSRCK0 bit	Meaning
0	x	x	0	Active-halt mode disabled
0	0	x	x	
0	1	1	1	
1	x	x	x	Active-halt mode enabled
x	1	0	1	

8.4.1 Active-halt mode

Active-halt mode is the lowest power consumption mode of the MCU with a real time clock available. It is entered by executing the 'HALT' instruction when Active-halt mode is enabled.

The MCU can exit Active-halt mode on reception of a Lite Timer / AT Timer interrupt or a reset.

- When exiting Active-halt mode by means of a reset, a 64 CPU cycle delay occurs. After the start up delay, the CPU resumes operation by fetching the reset vector which woke it up (see [Figure 22](#)).
- When exiting Active-halt mode by means of an interrupt, the CPU immediately resumes operation by servicing the interrupt vector which woke it up (see [Figure 22](#)).

When entering Active-halt mode, the I bit in the CC register is cleared to enable interrupts. Therefore, if an interrupt is pending, the MCU wakes up immediately.

In Active-halt mode, only the main oscillator and the selected timer counter (LT/AT) are running to keep a wakeup time base. All other peripherals are not clocked, except those which get their clock supply from another clock generator (such as external or auxiliary oscillator).

Caution: As soon as Active-halt is enabled, executing a HALT instruction while the watchdog is active does not generate a reset if the WDGHALT bit is reset. This means that the device cannot spend more than a defined delay in this power saving mode.

Figure 21. Active-halt timing overview

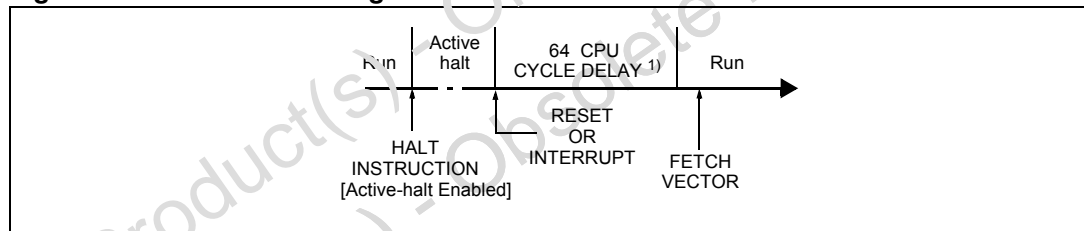
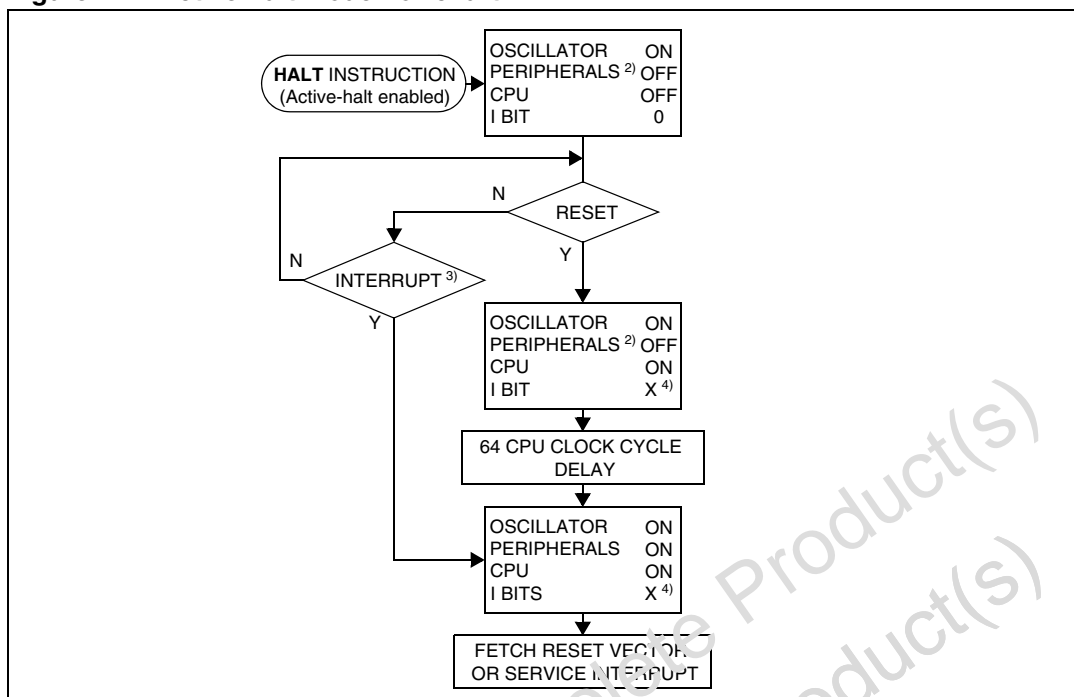

Figure 22. Active-halt mode flowchart



1. This delay occurs only if the MCU exits Active-halt mode by means of a reset.
2. Peripherals clocked with an external clock source can still be active.
3. Only the Lite Timer RTC and AT Timer interrupts can exit the MCU from Active-halt mode.
4. Before servicing an interrupt, the CC register is pushed on the stack. The I bit of the CC register is set during the interrupt routine and cleared when the CC register is popped.

8.4.2 Halt mode

The Halt mode is the lowest power consumption mode of the MCU. It is entered by executing the 'HALT' instruction when Active-halt mode is disabled.

The MCU can exit Halt mode on reception of either a specific interrupt (see [Table 9: Interrupt mapping](#)) or a reset. When exiting Halt mode by means of a reset or an interrupt, the main oscillator is immediately turned on and the 64 CPU cycle delay is used to stabilize it. After the start up delay, the CPU resumes operation by servicing the interrupt or by fetching the reset vector which woke it up (see [Figure 24](#)).

When entering Halt mode, the I bit in the CC register is forced to 0 to enable interrupts. Therefore, if an interrupt is pending, the MCU wakes immediately.

In Halt mode, the main oscillator is turned off causing all internal processing to be stopped, including the operation of the on-chip peripherals. All peripherals are not clocked except the ones which get their clock supply from another clock generator (such as an external or auxiliary oscillator).

The compatibility of watchdog operation with Halt mode is configured by the "WDGHALT" option bit of the option byte. The HALT instruction when executed while the watchdog system is enabled, can generate a watchdog reset (see [Section 14.1: Option bytes](#) for more details).

Figure 23. Halt timing overview

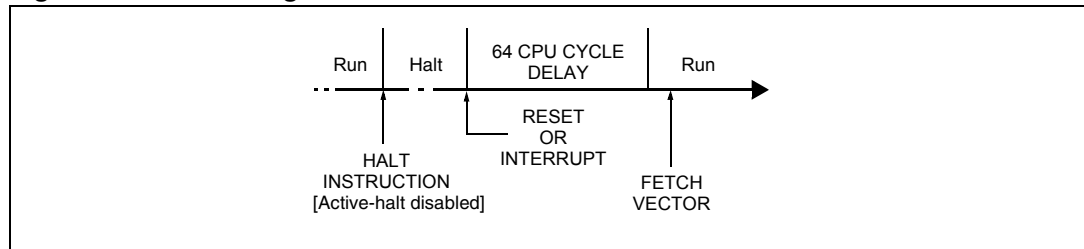

1. A reset pulse of at least 42µs must be applied when exiting from Halt mode.

Figure 24. Halt mode flowchart

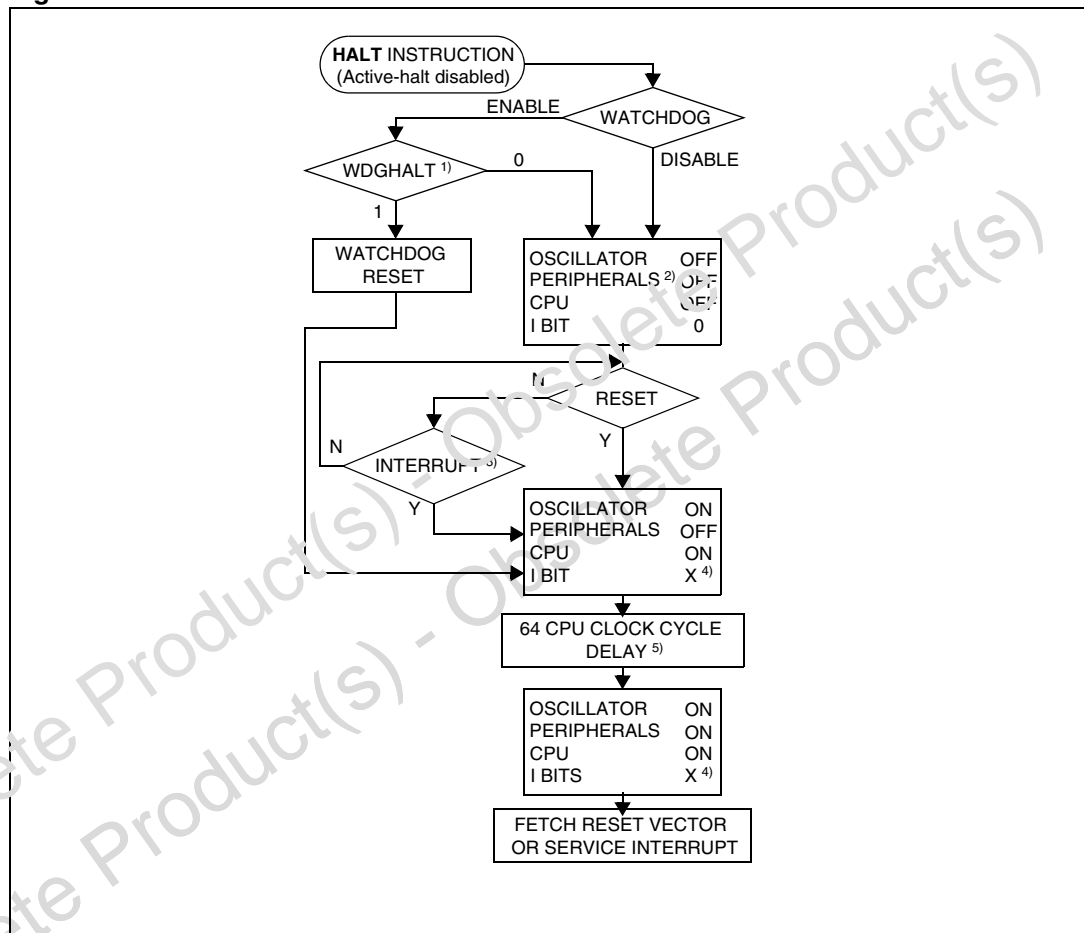

1. WDGHALT is an option bit. See option byte section for more details.
2. Peripheral clocked with an external clock source can still be active.
3. Only some specific interrupts can exit the MCU from Halt mode (such as external interrupt). Refer to [Table 9: Interrupt mapping](#) for more details.
4. Before servicing an interrupt, the CC register is pushed on the stack. The I bit of the CC register is set during the interrupt routine and cleared when the CC register is popped.
5. The CPU clock must be switched to 1 MHz (RC/8) or AWU RC before entering Halt mode.

Halt mode recommendations

- Make sure that an external event is available to wakeup the microcontroller from Halt mode.
- When using an external interrupt to wakeup the microcontroller, reinitialize the corresponding I/O as “Input Pull-up with Interrupt” before executing the HALT instruction. The main reason for this is that the I/O may be wrongly configured due to external interference or by an unforeseen logical condition.
- For the same reason, reinitialize the level sensitiveness of each external interrupt as a precautionary measure.
- The opcode for the HALT instruction is 0x8E. To avoid an unexpected HALT instruction due to a program counter failure, it is advised to clear all occurrences of the data value 0x8E from memory. For example, avoid defining a constant in ROM with the value 0x8E.
- As the HALT instruction clears the I bit in the CC register to allow interrupts, the user may choose to clear all pending interrupt bits before executing the HALT instruction. This avoids entering other peripheral interrupt routines after executing the external interrupt routine corresponding to the wakeup event (reset or external interrupt).

8.5 Auto-wakeup from Halt mode

Auto-wakeup from Halt (AWUFH) mode is similar to Halt mode with the addition of a specific internal RC oscillator for wakeup (Auto-wakeup from Halt oscillator) which replaces the main clock which was active before entering Halt mode. Compared to Active-halt mode, AWUFH has lower power consumption (the main clock is not kept running), but there is no accurate realtime clock available.

It is entered by executing the HALT instruction when the AWUEN bit in the AWUCSR register has been set.

Figure 25. AWUFH mode block diagram

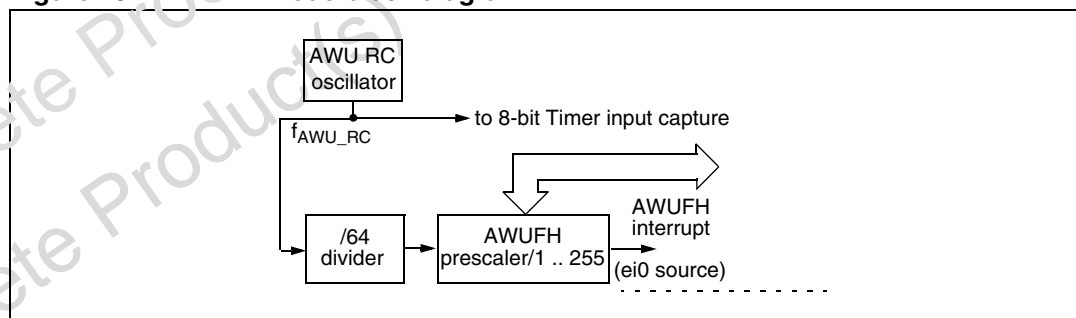

As soon as Halt mode is entered, and if the AWUEN bit has been set in the AWUCSR register, the AWU RC oscillator provides a clock signal (f_{AWU_RC}). Its frequency is divided by a fixed divider and a programmable prescaler controlled by the AWUPR register. The output of this prescaler provides the delay time. When the delay has elapsed, the following actions are performed:

- The AWUF flag is set by hardware,
- An interrupt wakes-up the MCU from Halt mode,
- The main oscillator is immediately turned on and the 64 CPU cycle delay is used to stabilize it.

After this startup delay, the CPU resumes operation by servicing the AWUFH interrupt. The AWU flag and its associated interrupt are cleared by software reading the AWUCSR register.

To compensate for any frequency dispersion of the AWU RC oscillator, it can be calibrated by measuring the clock frequency f_{AWU_RC} and then calculating the right prescaler value. Measurement mode is enabled by setting the AWUM bit in the AWUCSR register in Run mode. This connects f_{AWU_RC} to the input capture of the 8-bit lite timer, allowing the f_{AWU_RC} to be measured using the main oscillator clock as a reference timebase.

Similarities with Halt mode

The following AWUFH mode behavior is the same as normal Halt mode:

- The MCU can exit AWUFH mode by means of any interrupt with exit from Halt capability or a reset (see [Section 8.4: Active-halt and Halt modes](#)).
- When entering AWUFH mode, the I bit in the CC register is forced to 0 to enable interrupts. Therefore, if an interrupt is pending, the MCU wakes up immediately.
- In AWUFH mode, the main oscillator is turned off causing all internal processing to be stopped, including the operation of the on-chip peripherals. None of the peripherals are clocked except those which get their clock supply from another clock generator (such as an external or auxiliary oscillator like the AWU oscillator).
- The compatibility of watchdog operation with AWUFH mode is configured by the WDGHALT option bit in the option byte. Depending on this setting, the HALT instruction when executed while the watchdog system is enabled, can generate a watchdog reset.

Figure 26. AWUF Halt timing diagram

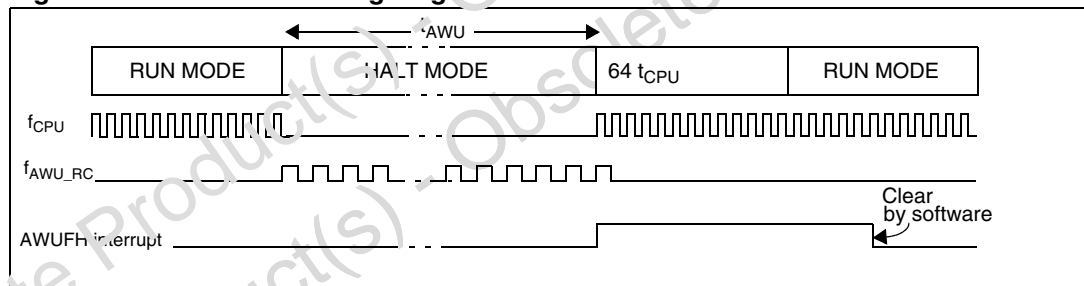
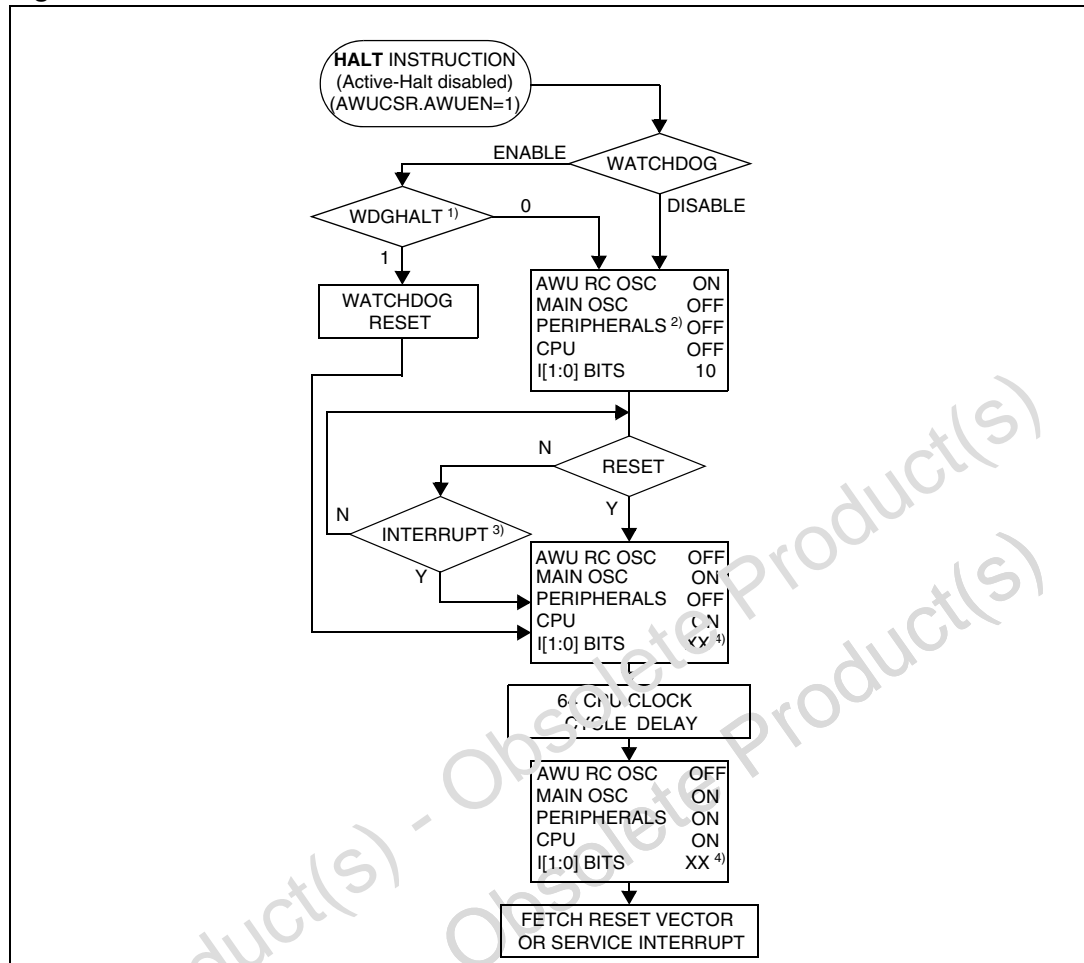

Figure 27. AWUFH mode flowchart



1. WDGHALT is an option bit. See option byte section for more details.
2. Peripheral clocked with an external clock source can still be active.
3. Only an AWUFH interrupt and some specific interrupts can exit the MCU from Halt mode (such as external interrupt). Refer to [Table 9: Interrupt mapping](#) for more details.
4. Before servicing an interrupt, the CC register is pushed on the stack. The I[1:0] bits of the CC register are set to the current software priority level of the interrupt routine and recovered when the CC register is popped.

8.5.1 Register description

AWUFH Control/ Status register (AWUCSR)

Reset value: 0000 0000 (00h)

7							0	
0	0	0	0	0	0	AWUF	AWUM	AWUEN
Read/Write								

Bits 7:3 Reserved

Bit 2 AWUF *Auto-wakeup Flag*

This bit is set by hardware when the AWU module generates an interrupt and cleared by software on reading AWUCSR. Writing to this bit does not change its value.

- 0: No AWU interrupt occurred
- 1: AWU interrupt occurred

Bit 1 AWUM *Auto-wakeup Measurement*

This bit enables the AWU RC oscillator and connects its output to the input capture of the 8-bit Lite timer. This allows the timer to be used to measure the AWU RC oscillator dispersion and then compensate this dispersion by providing the right value in the AWUPRE register.

- 0: Measurement disabled
- 1: Measurement enabled

Bit 0 AWUEN *Auto-wakeup From Halt Enabled*

This bit enables the Auto-wakeup From Halt feature: once Halt mode is entered, the AWUFH wakes up the microcontroller after a time delay dependent on the AWU prescaler value. It is set and cleared by software.

- 0: AWUFH (Auto-wakeup From Halt) mode disabled
- 1: AWUFH (Auto-wakeup From Halt) mode enabled

Note: Whatever the clock source, this bit should be set to enable the AWUFH mode once the HALT instruction has been executed.

AWUFH Prescaler register (AWUPR)

Reset value: 1111 1111 (FFh)

7							0
AWUPR7	AWUPR6	AWUPR5	AWUPR4	AWUPR3	AWUPR2	AWUPR1	AWUPR0
Read/Write							

Bits 7:0 **AWUPR[7:0]** *Auto-wakeup Prescaler*

These 8 bits define the AWUPR Dividing factor (see [Table 15: Configuring the dividing factor](#))

Table 15. Configuring the dividing factor

AWUPR[7:0]	Dividing factor
00h	Forbidden
01h	1
...	...
FEh	254
FFh	255

In AWU mode, the period that the MCU stays in Halt Mode (t_{AWU} in *Figure 26*) is defined by

$$t_{AWU} = 64 \times AWUPR \times \frac{1}{f_{AWURC}} + t_{RCSTRT}$$

This prescaler register can be programmed to modify the time that the MCU stays in Halt mode before waking up automatically.

Note: If 00h is written to AWUPR, depending on the product, an interrupt is generated immediately after a HALT instruction, or the AWUPR remains unchanged.

Table 16. AWU register map and reset values

Address (Hex.)	Register label	7	6	5	4	3	2	1	0
0049h	AWUPR Reset value	AWUP R7 1	AWUP R6 1	AWUP R5 1	AWUP R4 1	AWUP R3 1	AWUP R2 1	AWUP R1 1	AWUP R0 1
004Ah	AWUCSR Reset value	0	0	0	0	0	AWUF	AWUM	AWUE N

9 I/O ports

9.1 Introduction

The I/O port offers different functional modes:

- Transfer of data through digital inputs and outputs

and for specific pins:

- External interrupt generation
- Alternate signal input/output for the on-chip peripherals.

An I/O port contains up to 6 pins. Each pin (except PA3/ $\overline{\text{RESET}}$) can be programmed independently as digital input (with or without interrupt generation) or digital output

9.2 Functional description

Each port has 2 main registers:

- Data register (DR)
- Data Direction register (DDR)

and one optional register:

- Option register (OR)

Each I/O pin may be programmed using the corresponding register bits in the DDR and OR registers: bit X corresponding to pin X of the port. The same correspondence is used for the DR register.

The following description takes into account the OR register, (for specific ports which do not provide this register refer to the I/O Port Implementation section). The generic I/O block diagram is shown in [Figure 28](#).

9.2.1 Input modes

The input configuration is selected by clearing the corresponding DDR register bit.

In this case, reading the DR register returns the digital value applied to the external I/O pin.

Different input modes can be selected by software through the OR register.

- Note:*
- 1 Writing the DR register modifies the latch value but does not affect the pin status.
 - 2 PA3 cannot be configured as input.

External interrupt function

When an I/O is configured as Input with Interrupt, an event on this I/O can generate an external interrupt request to the CPU.

Each pin can independently generate an interrupt request. The interrupt sensitivity is independently programmable using the sensitivity bits in the EICR register.

External interrupts are hardware interrupts. Fetching the corresponding interrupt vector automatically clears the request latch. Changing the sensitivity of a particular external interrupt clears this pending interrupt. This can be used to clear unwanted pending interrupts.

Spurious interrupts

When enabling/disabling an external interrupt by setting/resetting the related OR register bit, a spurious interrupt is generated if the pin level is low and its edge sensitivity includes falling/rising edge. This is due to the edge detector input which is switched to '1' when the external interrupt is disabled by the OR register.

To avoid this unwanted interrupt, a "safe" edge sensitivity (rising edge for enabling and falling edge for disabling) has to be selected before changing the OR register bit and configuring the appropriate sensitivity again.

Caution: In case a pin level change occurs during these operations (asynchronous signal input), as interrupts are generated according to the current sensitivity, it is advised to disable all interrupts before and to reenale them after the complete previous sequence in order to avoid an external interrupt occurring on the unwanted edge.

This corresponds to the following steps:

1. To enable an external interrupt:
 - a) Set the interrupt mask with the SIM instruction (in cases where a pin level change could occur)
 - b) Select rising edge
 - c) Enable the external interrupt through the OR register
 - d) Select the desired sensitivity if different from rising edge
 - e) Reset the interrupt mask with the RIM instruction (in cases where a pin level change could occur)
2. To disable an external interrupt:
 - a) Set the interrupt mask with the SIM instruction SIM (in cases where a pin level change could occur)
 - b) Select falling edge
 - c) Disable the external interrupt through the OR register
 - d) Select rising edge

9.2.2 Output modes

The output configuration is selected by setting the corresponding DDR register bit. In this case, writing the DR register applies this digital value to the I/O pin through the latch. Then reading the DR register returns the previously stored value.

Two different output modes can be selected by software through the OR register: Output push-pull and open-drain.

Table 17. DR register value and output pin status⁽¹⁾

DR	Push-pull	Open-drain
0	V _{SS}	V _{SS}
1	V _{DD}	Floating

1. When switching from input to output mode, the DR register has to be written first to drive the correct level on the pin as soon as the port is configured as an output.

9.2.3 Alternate functions

When an on-chip peripheral is configured to use a pin, the alternate function is automatically selected. This alternate function takes priority over the standard I/O programming under the following conditions:

- When the signal is coming from an on-chip peripheral, the I/O pin is automatically configured in output mode (push-pull or open drain according to the peripheral).
- When the signal is going to an on-chip peripheral, the I/O pin must be configured in floating input mode. In this case, the pin state is also digitally readable by addressing the DR register.

- Note:*
- 1 Input pull-up configuration can cause unexpected value at the input of the alternate peripheral input.
 - 2 When an on-chip peripheral use a pin as input and output, this pin has to be configured in input floating mode.

Figure 28. I/O port general block diagram

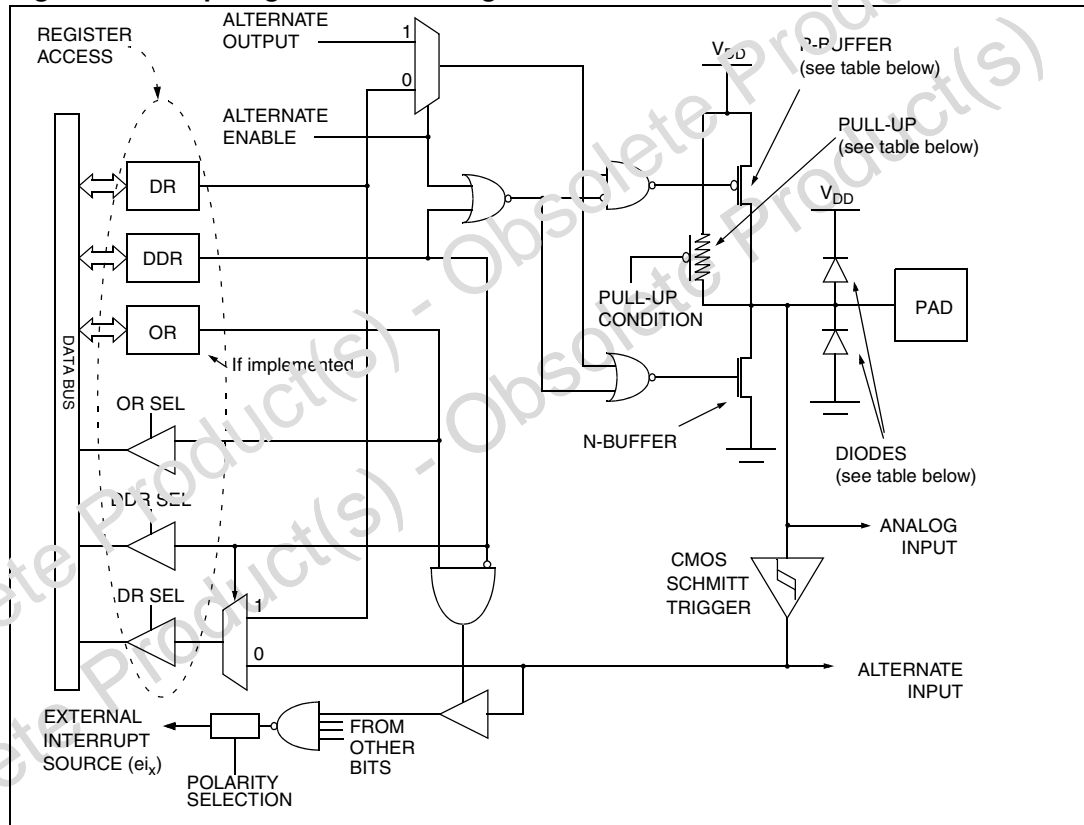
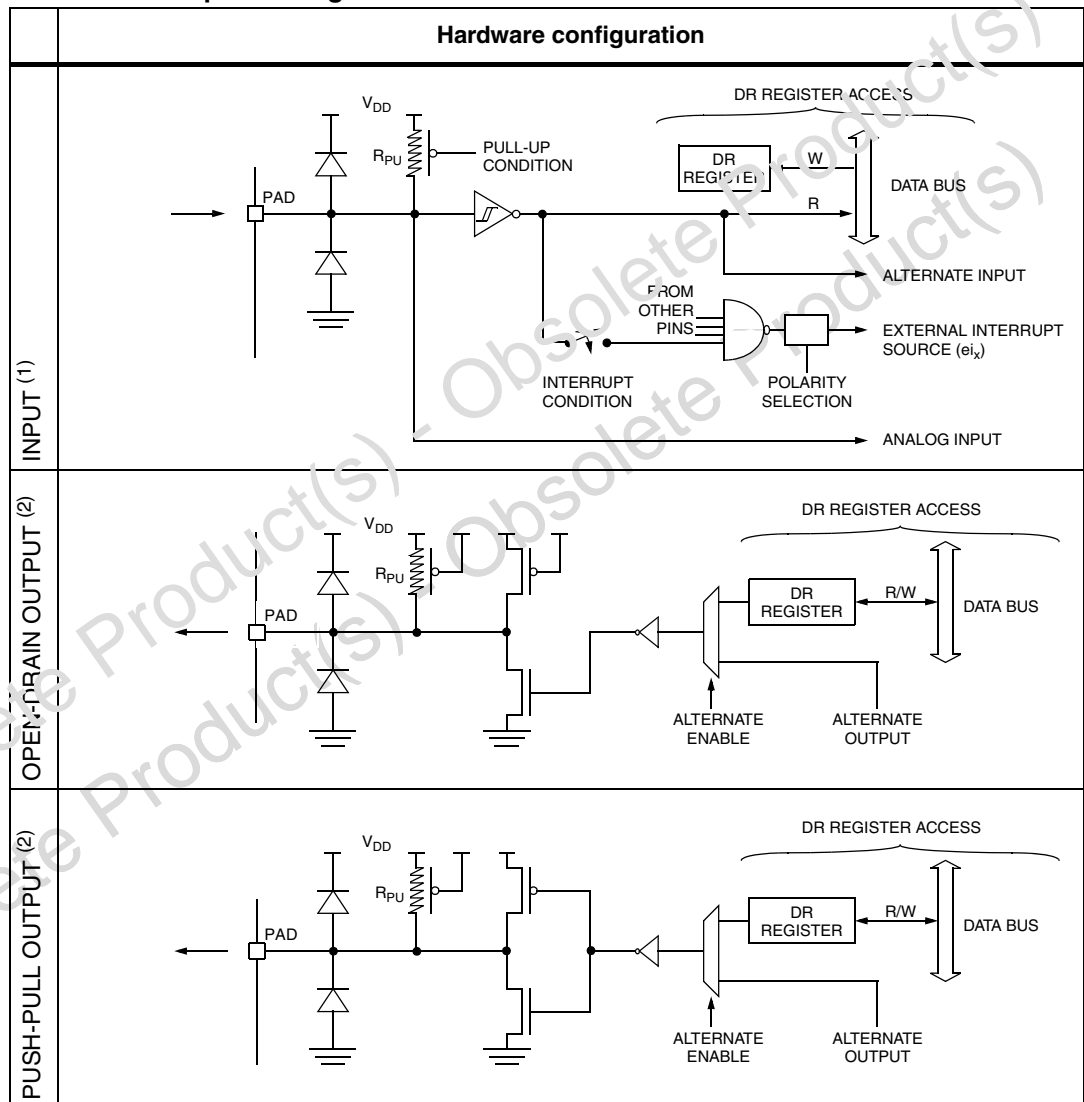

Table 18. I/O port mode options⁽¹⁾

Configuration mode		Pull-up	P-buffer	Diodes	
				to V _{DD}	to V _{SS}
Input	Floating with/without Interrupt	Off	Off	On	On
	Pull-up with/without Interrupt	On			
Output	Push-pull	Off	On	On	On
	Open Drain (logic level)		Off		

1. NI stands for not implemented; Off for implemented not activated; On for implemented and activated.

Table 19. I/O port configurations



1. When the I/O port is in input configuration and the associated alternate function is enabled as an output, reading the DR register will read the alternate function output status.
2. When the I/O port is in output configuration and the associated alternate function is enabled as an input, the alternate function reads the pin status given by the DR register content.

Caution: The alternate function must not be activated as long as the pin is configured as input with interrupt, in order to avoid generating spurious interrupts.

Analog alternate function

When the pin is used as an ADC input, the I/O must be configured as floating input. The analog multiplexer (controlled by the ADC registers) switches the analog voltage present on the selected pin to the common analog rail which is connected to the ADC input.

It is recommended not to change the voltage level or loading on any port pin while conversion is in progress. Furthermore it is recommended not to have clocking pins located close to a selected analog pin.

Warning: The analog input voltage level must be within the limits stated in the absolute maximum ratings.

9.3 Unused I/O pins

Unused I/O pins must be connected to fixed voltage levels. Refer to [Section 12.8](#).

9.4 Low power modes

Table 20. Effect of low power modes on I/O ports

Mode	Description
Wait	No effect on I/O ports. External interrupts cause the device to exit from Wait mode.
Halt	No effect on I/O ports. External interrupts cause the device to exit from Halt mode.

9.5 Interrupts

The external interrupt event generates an interrupt if the corresponding configuration is selected with DDR and OR registers and the interrupt mask in the CC register is not active (RIM instruction).

Table 21. Description of interrupt events

Interrupt event	Event flag	Enable control bit	Exit from Wait	Exit from Halt
External interrupt on selected external event	-	DDRx ORx	Yes	Yes

9.6 I/O port implementation

The hardware implementation on each I/O port depends on the settings in the DDR and OR registers and specific feature of the I/O port such as ADC Input or true open drain.

Switching these I/O ports from one state to another should be done in a sequence that prevents unwanted side effects. Recommended safe transitions are illustrated in [Figure 29](#). Other transitions are potentially risky and should be avoided, since they are likely to present unwanted side-effects such as spurious interrupt generation.

Figure 29. Interrupt I/O port state transitions

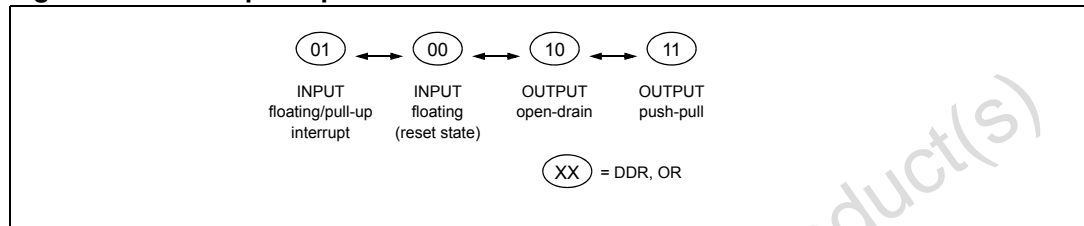

The I/O port register configurations are summarized in [Table 22](#)

Table 22. Port configuration

Port	Pin name	Input (DDR=0)		Output (DDR=1)	
		OR = 0	OR = 1	OR = 0	OR = 1
Port A	PA0:2, PA4:5	floating	pull-up interrupt	open drain	push-pull
	PA3	-	-	open drain	push-pull

After reset, to configure PA3 as a general purpose output, the application has to program the MUXCR0 and MUXCR1 registers. See [Section 6.5: Register description on page 37](#)

Table 23. I/O port register map and reset values

Address (Hex.)	Register label	7	6	5	4	3	2	1	0
0000h	PADR Reset value	MSB 0	0	0	0	0	0	0	LSB 0
0001h	PADDR Reset value	MSB 0	0	0	0	1	0	0	LSB 0
0002h	PAOR Reset value	MSB 0	0	0	0	0	0	1	LSB 0

10 On-chip peripherals

10.1 Lite timer (LT)

10.1.1 Introduction

The Lite Timer can be used for general-purpose timing functions. It is based on a free-running 13-bit upcounter with two software-selectable timebase periods, an 8-bit input capture register and watchdog function.

10.1.2 Main features

- Real-time clock
 - 13-bit upcounter
 - 1 ms or 2 ms timebase period (@ 8 MHz f_{OSC})
 - Maskable timebase interrupt
- Input capture
 - 8-bit input capture register (LTICR)
 - Maskable interrupt with wakeup from Halt mode capability
- Watchdog
 - Enabled by hardware or software (configurable by option byte)
 - Optional reset on HALT instruction (configurable by option byte)
 - Automatically resets the device unless disable bit is refreshed
 - Software reset (forced watchdog reset)
 - Watchdog reset status flag

Figure 30. Lite timer block diagram

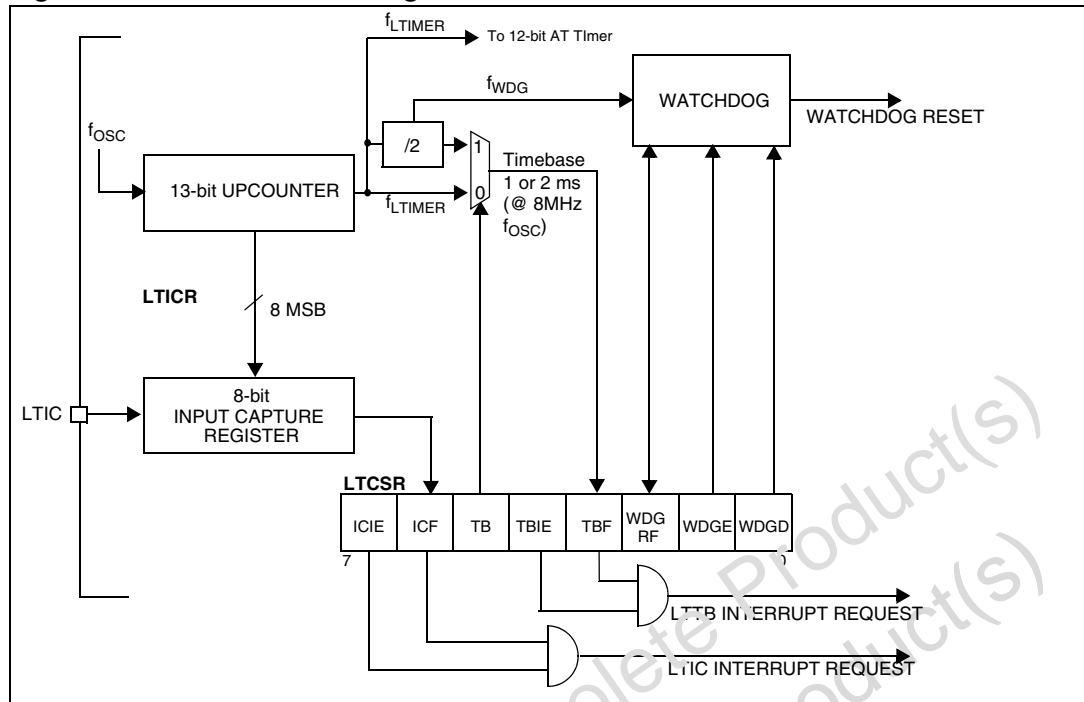

10.1.3 Functional description

The value of the 13-bit counter cannot be read or written by software. After an MCU reset, it starts incrementing from 0 at a frequency of f_{OSC} . A counter overflow event occurs when the counter rolls over from 1F39h to 00h. If $f_{OSC} = 8\text{ MHz}$, then the time period between two counter overflow events is 1 ms. This period can be doubled by setting the TB bit in the LTCSR register.

When the timer overflows, the TBF bit is set by hardware and an interrupt request is generated if the TBIE is set. The TBF bit is cleared by software reading the LTCSR register.

Watchdog

The watchdog is enabled using the WDGE bit. The normal watchdog timeout is 2 ms (@ $f_{OSC} = 8\text{ MHz}$), after which it then generates a reset.

To prevent this watchdog reset occurring, software must set the WDGD bit. The WDGD bit is cleared by hardware after t_{WDG} . This means that software must write to the WDGD bit at regular intervals to prevent a watchdog reset occurring. Refer to [Figure 31](#).

If the watchdog is not enabled immediately after reset, the first watchdog timeout will be shorter than 2ms, because this period is counted starting from reset. Moreover, if a 2ms period has already elapsed after the last MCU reset, the watchdog reset will take place as soon as the WDGE bit is set. For these reasons, it is recommended to enable the watchdog immediately after reset or else to set the WDGD bit before the WGDE bit so a watchdog reset will not occur for at least 2 ms.

Note: Software can use the timebase feature to set the WDGD bit at 1 or 2 ms intervals.

A watchdog reset can be forced at any time by setting the WDGRF bit. To generate a forced watchdog reset, first watchdog has to be activated by setting the WDGE bit and then the WDGRF bit has to be set.

The WDGRF bit also acts as a flag, indicating that the watchdog was the source of the reset. It is automatically cleared after it has been read.

Caution: When the WDGRF bit is set, software must clear it, otherwise the next time the watchdog is enabled (by hardware or software), the microcontroller will be immediately reset.

Hardware watchdog option

If hardware watchdog is selected by option byte, the watchdog is always active and the WDGE bit in the LTCSR is not used.

Refer to the option byte description in the "device configuration and ordering information" section.

Using Halt mode with the watchdog (option)

If the watchdog reset on Halt option is not selected by option byte, the Halt mode can be used when the watchdog is enabled.

In this case, the HALT instruction stops the oscillator. When the oscillator is stopped, the Lite Timer stops counting and is no longer able to generate a watchdog reset until the microcontroller receives an external interrupt or a reset.

If an external interrupt is received, the WDG restarts counting after 256 or 512 CPU clocks. If a reset is generated, the watchdog is disabled (reset state).

If Halt mode with watchdog is enabled by option byte (No watchdog reset on HALT instruction), it is recommended before executing the HALT instruction to refresh the WDG counter, to avoid an unexpected WDG reset immediately after waking up the microcontroller.

Figure 31. Watchdog timing diagram

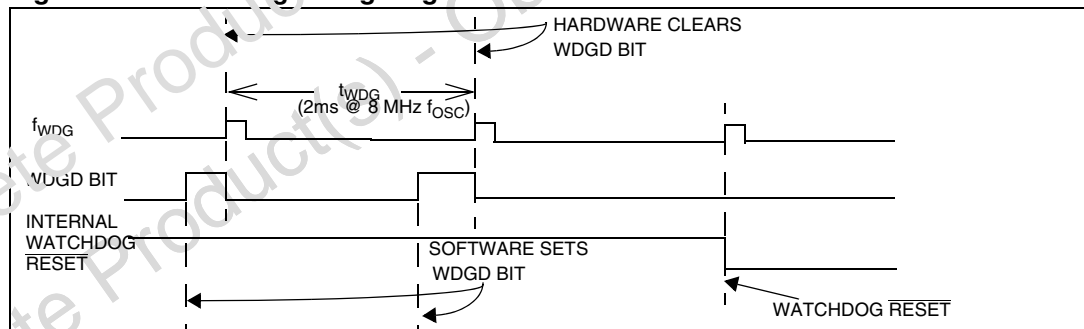

Input capture

The 8-bit input capture register is used to latch the free-running upcounter after a rising or falling edge is detected on the LTIC pin. When an input capture occurs, the ICF bit is set and the LTICR register contains the MSB of the free-running upcounter. An interrupt is generated if the ICIE bit is set. The ICF bit is cleared by reading the LTICR register.

The LTICR is a read only register and always contains the data from the last input capture. Input capture is inhibited if the ICF bit is set.

10.1.4 Low power modes

Table 24. Description of low power modes

Mode	Description
Wait	No effect on Lite timer
Active-Halt	No effect on Lite timer
Halt	Lite timer stops counting

10.1.5 Interrupts

Table 25. Interrupt events⁽¹⁾

Interrupt event	Event flag	Enable control bit	Exit from Wait	Exit from Halt	Exit from Active-halt
Timebase Event	TBF	TBIE	Yes	No	Yes
IC Event	ICF	ICIE	Yes	No	No

1. The TBF and ICF interrupt events are connected to separate interrupt vectors (see Interrupts chapter).

They generate an interrupt if the enable bit is set in the LTCSR register and the interrupt mask in the CC register is reset (RIM instruction).

Figure 32. Input capture timing diagram

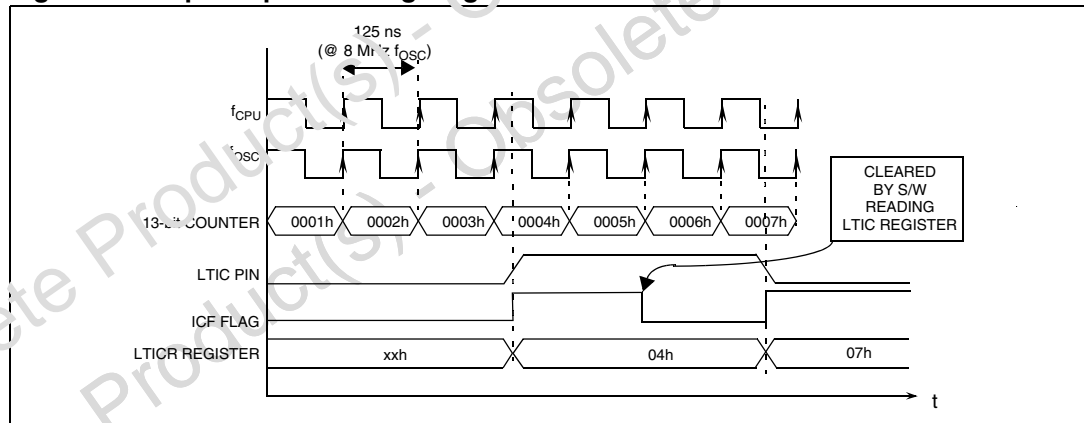

10.1.6 Register description

Lite timer control/status register (LTCSR)

Reset value: 0000 0x00 (0xh)

7	ICIE	ICF	TB	TBIE	TBF	WDGR	WDGE	WDGD	0
Read / Write									

Bit 7 **ICIE** *Interrupt Enable.*

This bit is set and cleared by software.
 0: Input Capture (IC) interrupt disabled
 1: Input Capture (IC) interrupt enabled

Bit 6 **ICF** *Input Capture Flag.*

This bit is set by hardware and cleared by software by reading the LTICR register. Writing to this bit does not change the bit value.

0: No input capture
 1: An input capture has occurred

Note: After an MCU reset, software must initialise the ICF bit by reading the LTICR register

Bit 5 **TB** *Timebase period selection.*

This bit is set and cleared by software.
 0: Timebase period = $t_{OSC} * 8000$ (1 ms @ 8 MHz)
 1: Timebase period = $t_{OSC} * 16000$ (2 ms @ 8 MHz)

Bit 4 **TBIE** *Timebase Interrupt enable.*

This bit is set and cleared by software.
 0: Timebase (TB) interrupt disabled
 1: Timebase (TB) interrupt enabled

Bit 3 **TBF** *Timebase Interrupt Flag.*

This bit is set by hardware and cleared by software reading the LTCSR register. Writing to this bit has no effect.
 0: No counter overflow
 1: A counter overflow has occurred

Bit 2 **WDGRF** *Force Reset/ Reset Status Flag*

This bit is used in two ways: it is set by software to force a watchdog reset. It is set by hardware when a watchdog reset occurs and cleared by hardware or by software. It is cleared by hardware only when an LVD reset occurs. It can be cleared by software after a read access to the LTCSR register.

0: No watchdog reset occurred.

1: Force a watchdog reset (write), or, a watchdog reset occurred (read).

Bit 1 **WDGE** *Watchdog Enable*

This bit is set and cleared by software.

0: Watchdog disabled

1: Watchdog enabled

Bit 0 **WDGD** *Watchdog Reset Delay*

This bit is set by software. It is cleared by hardware at the end of each WDG period.

0: Watchdog reset not delayed

1: Watchdog reset delayed

Lite Timer Input Capture register (LTICR)

Reset value: 0000 0000 (00h)

7	6	5	4	3	2	1	0
ICR7	ICR6	ICR5	ICR4	ICR3	ICR2	ICR1	ICR0
Read only							

Bit 7:0 **ICR[7:0]** *Input capture value*

These bits are read by software and cleared by hardware after a reset. If the ICF bit in the LTCSR is cleared, the value of the 8-bit up-counter will be captured when a rising or falling edge occurs on the LTIC pin.

Table 26. Lite timer register map and reset values

Address (Hex.)	Register label	7	6	5	4	3	2	1	0
0E	LTCSR Reset value	ICIE 0	ICF 0	TB 0	TBIE 0	TBF 0	WDGRF x	WDGE 0	WDGD 0
0C	LTICR Reset value	ICR7 0	ICR6 0	ICR5 0	ICR4 0	ICR3 0	ICR2 0	ICR1 0	ICR0 0

10.2 12-bit auto-reload timer (AT)

10.2.1 Introduction

The 12-bit auto-reload timer can be used for general-purpose timing functions. It is based on a free-running 12-bit upcounter with a PWM output channel.

10.2.2 Main features

- 12-bit upcounter with 12-bit auto-reload register (ATR)
- Maskable overflow interrupt
- PWM signal generator
- Frequency range 2 kHz - 4 MHz (@ 8 MHz f_{CPU})
 - Programmable duty-cycle
 - Polarity control
 - Maskable compare interrupt
- Output compare function

Figure 33. Block diagram

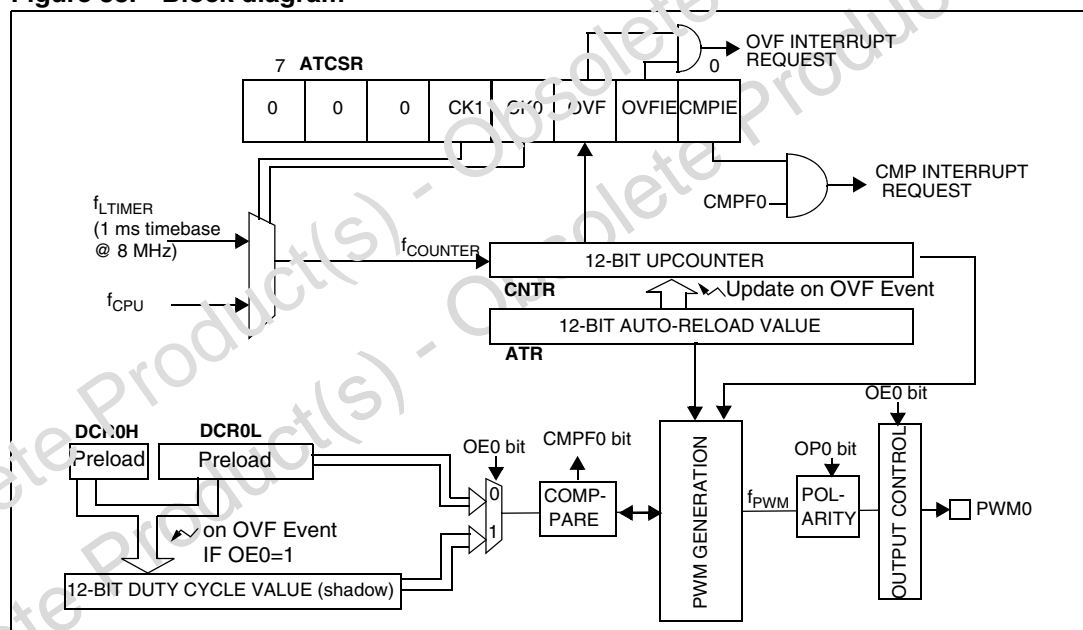

10.2.3 Functional description

PWM mode

This mode allows a pulse width modulated signals to be generated on the PWM0 output pin with minimum core processing overhead. The PWM0 output signal can be enabled or disabled using the OE0 bit in the PWMCR register. When this bit is set the PWM I/O pin is configured as output push-pull alternate function.

Note: CMPF0 is available in PWM mode (see [Section : PWM0 control/status register \(PWM0CSR\)](#)).

PWM frequency and duty cycle

The PWM signal frequency (f_{PWM}) is controlled by the counter period and the ATR register value.

$$f_{PWM} = f_{COUNTER} / (4096 - ATR)$$

Following the above formula, if f_{CPU} is 8 MHz, the maximum value of f_{PWM} is 4 MHz (ATR register value = 4094), and the minimum value is 2 kHz (ATR register value = 0).

Note: *The maximum value of ATR is 4094 because it must be lower than the DCR value which must be 4095 in this case.*

At reset, the counter starts counting from 0.

Software must write the duty cycle value in the DCR0H and DCR0L preload registers. The DCR0H register must be written first. See caution below.

When an upcounter overflow occurs (OVF event), the ATR value is loaded in the counter, the preloaded Duty cycle value is transferred to the Duty Cycle register and the PWM0 signal is set to a high level. When the upcounter matches the DCRx value the PWM0 signal is set to a low level. To obtain a signal on the PWM0 pin, the contents of the DCR0 register must be greater than the contents of the ATR register.

The polarity bit can be used to invert the output signal.

The maximum available resolution for the PWM0 duty cycle is:

$$\text{Resolution} = 1 / (4096 - ATR)$$

Note: *To get the maximum resolution (1/4096), the ATR register must be 0. With this maximum resolution and assuming that $DCR = ATR + 1$, a 0% or 100% duty cycle can be obtained by changing the polarity.*

Caution: As soon as the DCR0H is written, the compare function is disabled and will start only when the DCR0L value is written. If the DCR0H write occurs just before the compare event, the signal on the PWM output may not be set to a low level. In this case, the DCRx register should be updated just after an OVF event. If the DCR and ATR values are close, then the DCRx register should be updated just before an OVF event, in order not to miss a compare event and to have the right signal applied on the PWM output.

Figure 34. PWM function

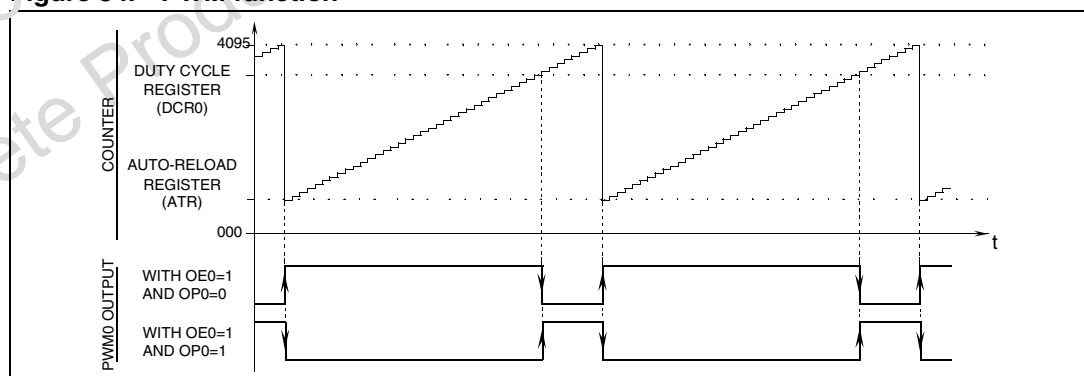
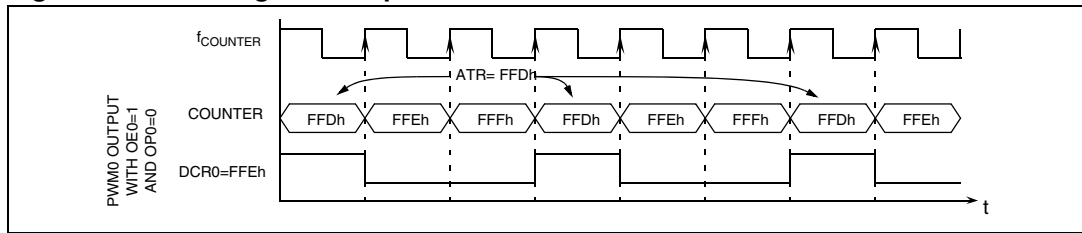

Figure 35. PWM signal example



Output compare mode

To use this function, the OE bit must be 0, otherwise the compare is done with the shadow register instead of the DCRx register. Software must then write a 12-bit value in the DCR0H and DCR0L registers. This value will be loaded immediately (without waiting for an OVF event).

The DCR0H must be written first, the output compare function starts only when the DCR0L value is written.

When the 12-bit upcounter (CNTR) reaches the value stored in the DCR0H and DCR0L registers, the CMPF0 bit in the PWM0CSR register is set and an interrupt request is generated if the CMPIE bit is set.

Note: The output compare function is only available for DCRx values other than 0 (reset value).

Caution: At each OVF event, the DCRx value is written in a shadow register, even if the DCR0L value has not yet been written (in this case, the shadow register will contain the new DCR0H value and the old DCR0L value), then:

- If OE=1 (PWM mode): the compare is done between the timer counter and the shadow register (and not DCRx)
 - If OE=0 (OCiF mode): the compare is done between the timer counter and DCRx. There is no PWM signal.
- The compare between DCRx or the shadow register and the timer counter is locked until DCR0L is written.

10.2.4 Low power modes

Table 27. Description of low power modes

Mode	Description
Slow	The input frequency is divided by 32
Wait	No effect on AT timer
Active-halt	AT timer halted except if CK0=1, CK1=0 and OVFIE=1
Halt	AT timer halted

10.2.5 Interrupts

Table 28. Interrupt events

Interrupt event ⁽¹⁾	Event flag	Enable control bit	Exit from Wait	Exit from Halt	Exit from Active-halt
Overflow event	OVF	OVFIE	Yes	No	Yes ⁽²⁾
CMP event	CMPF _x	CMPIE	Yes	No	No

- The interrupt events are connected to separate interrupt vectors (see Interrupts chapter). They generate an interrupt if the enable bit is set in the ATCSR register and the interrupt mask in the CC register is reset (RIM instruction).
- Only if CK0=1 and CK1=0

10.2.6 Register description

Timer control status register (ATCSR)

Reset value: 0000 0000 (00h)

7							0
0	0	0	CK1	CK0	OVF	OVFIE	CMPIE
Read/write							

Bits 7:5 Reserved, must be kept cleared.

Bits 4:3 **CK[1:0]** Counter Clock Selection.

These bits are set and cleared by software and cleared by hardware after a reset. They select the clock frequency of the counter (see [Table 29: Counter clock selection](#)).

Bit 2 **OVF** Overflow flag.

This bit is set by hardware and cleared by software by reading the ATCSR register. It indicates the transition of the counter from FFFh to ATR value.

- 0: No counter overflow occurred
- 1: Counter overflow occurred

When set, the OVF bit stays high for 1 f_{COUNTER} cycle (up to 1ms depending on the clock selection) after it has been cleared by software.

Bit 1 **OVFIE** Overflow interrupt enable.

This bit is read/write by software and cleared by hardware after a reset.

- 0: OVF interrupt disabled
- 1: OVF interrupt enabled

Bit 0 **CMPIE** Compare interrupt enable.

This bit is read/write by software and clear by hardware after a reset. It allows to mask the interrupt generation when CMPF bit is set.

- 0: CMPF interrupt disabled
- 1: CMPF interrupt enabled

Table 29. Counter clock selection

Counter clock selection	CK1	CK0
OFF	0	0
f_{TIMER} (1 ms timebase @ 8 MHz)	0	1
f_{CPU}	1	0
Reserved	1	1

Counter register high (CNTRH)

Reset value: 0000 0000 (00h)

15	0	0	0	0	CN11	CN10	CN9	8	CN8
Read only									

Counter register low (CNTRL)

This 12-bit register is read by software and cleared by hardware after a reset. The counter is incremented continuously as soon as a counter clock is selected. To obtain the 12-bit value, software should read the counter value in two consecutive read operations. As there is no latch, it is recommended to read LSB first. In this case, CNTRH can be incremented between the two read operations and to have an accurate result when $f_{\text{TIMER}} = f_{\text{CPU}}$, special care must be taken when CNTRL values close to FFh are read.

When a counter overflow occurs, the counter restarts from the value specified in the ATR register.

Reset value: 0000 0000 (00h)

7	CN7	CN6	CN5	CN4	CN3	CN2	CN1	0	CN0
Read only									

Bits 15:12 Reserved, must be kept cleared.

Bits 11:0 **CNTR[11:0]** Counter value.

Auto reload register (ATRH)

Reset value: 0000 0000 (00h)

15	0	0	0	0	ATR11	ATR10	ATR9	8	ATR8
Read/Write									

Auto reload register (ATRL)

This is a 12-bit register which is written by software. The ATR register value is automatically loaded into the upcounter when an overflow occurs. The register value is used to set the PWM frequency.

Reset value: 0000 0000 (00h)

7							0
ATR7	ATR6	ATR5	ATR4	ATR3	ATR2	ATR1	ATR0
Read/Write							

Bits 15:12 Reserved, must be kept cleared.

Bits 11:0 **ATR[11:0]** *Auto-reload Register*.

PWM0 duty cycle register high (DCR0H)

Reset value: 0000 0000 (00h)

15							8
0	0	0	0	DCR11	DCR10	DCR9	DCR8
Read/Write							

PWM0 duty cycle register low (DCR0L)

This 12-bit value is written by software. The high register must be written first. In PWM mode (OE0=1 in the PWMCR register) the DCR[11:0] bits define the duty cycle of the PWM0 output signal (see [Figure 34](#)). In Output Compare mode, (OE0=0 in the PWMCR register) they define the value to be compared with the 12-bit upcounter value.

Reset value: 0000 0000 (00h)

7							0
DCR7	DCR6	DCR5	DCR4	DCR3	DCR2	DCR1	DCR0
Read/Write							

Bits 15:12 Reserved, must be kept cleared.

Bits 11:0 **DCR[11:0]** *PWMx duty cycle value*

PWM0 control/status register (PWM0CSR)

Reset value: 0000 0000 (00h)

7							0
0	0	0	0	0	0	0	0
						OP0	CMPF0
Read/Write							

Bit 7:2 Reserved, must be kept cleared.

Bit 1 **OP0** PWM0 output polarity.

This bit is read/write by software and cleared by hardware after a reset. This bit selects the polarity of the PWM0 signal.

0: The PWM0 signal is not inverted.

1: The PWM0 signal is inverted.

Bit 0 **CMPF0** PWM0 Compare Flag.

This bit is set by hardware and cleared by software by reading the PWM0CSR register. It indicates that the upcounter value matches the DCR0 register value.

0: Upcounter value does not match DCR value.

1: Upcounter value matches DCR value.

PWM output control register (PWMCR)

Reset value: 0000 0000 (00h)

7							0
0	0	0	0	0	0	0	0
						OE0	
Read/Write							

Bits 7:1 Reserved, must be kept cleared.

Bit 0 **OE0** PWM0 Output enable.

This bit is set and cleared by software.

0: PWM0 output Alternate Function disabled (I/O pin free for general purpose I/O)

1: PWM0 output enabled

Table 30. Register map and reset values

Address (Hex.)	Register label	7	6	5	4	3	2	1	0
0D	ATCSR Reset value	0	0	0	CK1 0	CK0 0	OVF 0	OVFIE 0	CMPFIE 0
0E	CNTRH Reset value	0	0	0	0	CN11 0	CN10 0	CN9 0	CN8 0
0F	CNTRL Reset value	CN7 0	CN6 0	CN5 0	CN4 0	CN3 0	CN2 0	CN1 0	CN0 0
10	ATRH Reset value	0	0	0	0	ATR11 0	ATR10 0	ATR9 0	ATR8 0

Table 30. Register map and reset values (continued)

Address (Hex.)	Register label	7	6	5	4	3	2	1	0
11	ATRL Reset value	ATR7 0	ATR6 0	ATR5 0	ATR4 0	ATR3 0	ATR2 0	ATR1 0	ATR0 0
12	PWMCR Reset value	0	0	0	0	0	0	0	OE0 0
13	PWMCSR Reset value	0	0	0	0	0	0	OP 0	CMPF0 0
17	DCR0H Reset value	0	0	0	0	DCR11 0	DCR10 0	DCR9 0	DCR8 0
18	DCR0L Reset value	DCR7 0	DCR6 0	DCR5 0	DCR4 0	DCR3 0	DCR2 0	DCR1 0	DCR0 0

10.3 10-bit A/D converter (ADC)

10.3.1 Introduction

The on-chip Analog to Digital Converter (ADC) peripheral is a 10-bit, successive approximation converter with internal sample and hold circuitry. This peripheral has up to 5 multiplexed analog input channels (refer to device pin out description) that allow the peripheral to convert the analog voltage levels from up to 5 different sources.

The result of the conversion is stored in a 10-bit Data register. The A/D converter is controlled through a Control/Status register.

10.3.2 Main features

- 10-bit conversion
- Up to 5 channels with multiplexed input
- Linear successive approximation
- Data register (DR) which contains the results
- Conversion complete status flag
- On/off bit (to reduce consumption)

The block diagram is shown in [Figure 36](#).

10.3.3 Functional description

Analog power supply

V_{DDA} and V_{SSA} are the high and low level reference voltage pins. In some devices (refer to device pin out description) they are internally connected to the V_{DD} and V_{SS} pins.

Conversion accuracy may therefore be impacted by voltage drops and noise in the event of heavily loaded or badly decoupled power supply lines.

Figure 36. ADC block diagram

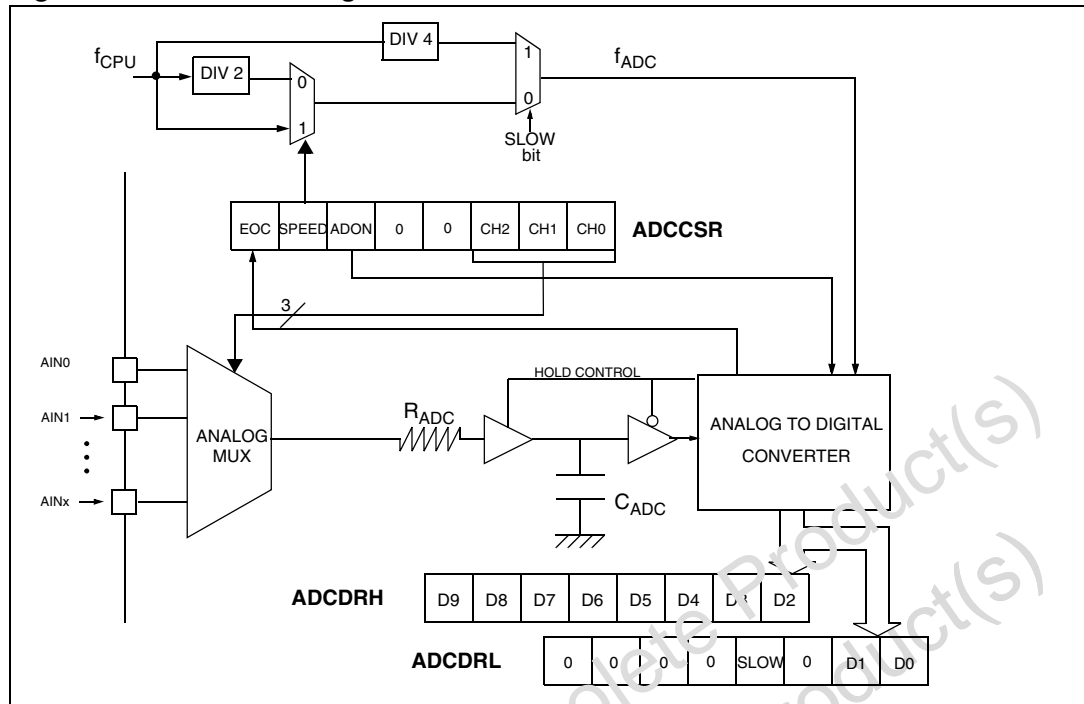

Digital A/D conversion result

The conversion is monotonic, meaning that the result never decreases if the analog input does not and never increases if the analog input does not.

If the input voltage (V_{AIN}) is greater than V_{DDA} (high-level voltage reference) then the conversion result is FFh in the ADCDRH register and 03h in the ADCDRL register (without overflow indication).

If the input voltage (V_{AIN}) is lower than V_{SSA} (low-level voltage reference) then the conversion result in the ADCDRH and ADCDRL registers is 00 00h.

The A/D converter is linear and the digital result of the conversion is stored in the ADCDRH and ADCDRL registers. The accuracy of the conversion is described in the Electrical Characteristics Section.

R_{AIN} is the maximum recommended impedance for an analog input signal. If the impedance is too high, this will result in a loss of accuracy due to leakage and sampling not being completed in the allotted time.

A/D conversion phases

The A/D conversion is based on two conversion phases:

- Sample capacitor loading [duration: t_{SAMPLE}]
During this phase, the V_{AIN} input voltage to be measured is loaded into the C_{ADC} sample capacitor.
- A/D conversion [duration: t_{HOLD}]
During this phase, the A/D conversion is computed (8 successive approximations

cycles) and the C_{ADC} sample capacitor is disconnected from the analog input pin to get the optimum analog to digital conversion accuracy.

- The total conversion time:
 $t_{CONV} = t_{SAMPLE} + t_{HOLD}$

While the ADC is on, these two phases are continuously repeated.

At the end of each conversion, the sample capacitor is kept loaded with the previous measurement load. The advantage of this behavior is that it minimizes the current consumption on the analog pin in case of single input channel measurement.

A/D conversion

The analog input ports must be configured as input, no pull-up, no interrupt. Refer to the “I/O ports” chapter. Using these pins as analog inputs does not affect the ability of the port to be read as a logic input.

In the ADCCSR register, select the CS[2:0] bits to assign the analog channel to convert.

ADC conversion mode

In the ADCCSR register, set the ADON bit to enable the A/D converter and to start the conversion. From this time on, the ADC performs a continuous conversion of the selected channel. When a conversion is complete:

- The EOC bit is set by hardware.
- The result is in the ADCDR registers.

A read to the ADCDRH resets the EOC bit.

To read the 10 bits, perform the following steps:

1. Poll EOC bit
2. Read ADCDRL
3. Read ADCDRH. This clears EOC automatically.

To read only 5 bits, perform the following steps:

1. Poll EOC bit
1. Read ADCDRH. This clears EOC automatically.

10.3.4 Low power modes

The A/D converter may be disabled by resetting the ADON bit. This feature allows reduced power consumption when no conversion is needed and between single shot conversions.

Table 31. Effect of low power modes

Mode	Description
Wait	No effect on A/D converter
Halt	A/D converter disabled. After wakeup from Halt mode, the A/D converter requires a stabilization time t_{STAB} (see Section 12: Electrical characteristics) before accurate conversions can be performed.

10.3.5 Interrupts

None.

10.3.6 Register description

Control/Status register (ADCCSR)

Reset value: 0000 0000 (00h)

7	6	5	4	3	2	1	0
EOC	SPEED	ADON	0	0	CH2	CH1	CH0
Read/Write (Except bit 7 read only)							

Bit 7 EOC *End of Conversion*

This bit is set by hardware. It is cleared by software reading the ADCDRH register.

0: Conversion is not complete

1: Conversion complete

Bit 6 SPEED *ADC clock selection*

This bit is set and cleared by software. It is used together with the SLOW bit to configure the ADC clock speed. Refer to the table in the SLOW bit description.

Bit 5 ADON *A/D Converter on*

This bit is set and cleared by software.

0: A/D converter is switched off

1: A/D converter is switched on

Bits 4:3 **Reserved.** Must be kept cleared.

Bits 2:0 **CH[2:0]** *Channel Selection*

These bits are set and cleared by software. They select the analog input to convert.

Note: A write to the ADC CSR register (with ADON set) aborts the current conversion, resets the EOC bit and starts a new conversion.

Table 32. Channel selection

Channel pin	CH2	CH1	CH0
AIN0	0	0	0
AIN1	0	0	1
AIN2	0	1	0
AIN3	0	1	1
AIN4	1	0	0

ADC data register high (ADCDRH)

Reset value: 0000 0000 (00h)

7							0
D9	D8	D7	D6	D5	D4	D3	D2
Read only							

Bits 7:0 D[9:2] MSB of Analog Converted value

ADC control/data register Low (ADCDRL)

Reset value: 0000 0000 (00h)

7							0
0	0	0	0	SLOW	0	D1	D0
Read/write							

Bits 7:4 Reserved. Forced by hardware to 0.

Bit 3 **SLOW** *Slow mode*

This bit is set and cleared by software. It is used together with the SPEED bit to configure the ADC clock speed as shown on the table below (see [Table 33: Configuring the ADC clock speed](#)).

Bit 2 Reserved. Forced by hardware to 0.

Bits 1:0 D[1:0] LSB of Analog Converted value

Table 33. Configuring the ADC clock speed

f _{ADC}	SLOW	SPEED
f _{CPU} /2	0	0
f _{CPU}	0	1
f _{CPU} /4	1	x

Table 34. ADC register map and reset values

Address (Hex.)	Register label	7	6	5	4	3	2	1	0
0034h	ADCCSR Reset value	EOC 0	SPEED 0	ADON 0	0 0	0 0	CH2 0	CH1 0	CH0 0
0035h	ADCDRH Reset value	D9 0	D8 0	D7 0	D6 0	D5 0	D4 0	D3 0	D2 0
0036h	ADCDRL Reset value	0 0	0 0	0 0	0 0	SLOW 0	0 0	D1 0	D0 0

11 Instruction set

11.1 ST7 addressing modes

The ST7 Core features 17 different addressing modes which can be classified in seven main groups:

Table 35. Description of addressing modes

Addressing mode	Example
Inherent	nop
Immediate	ld A,#\$55
Direct	ld A,\$55
Indexed	ld A,(\$55,X)
Indirect	ld A,[@\$55,X]
Relative	jmp loop
Bit operation	bset byte,#5

The ST7 instruction set is designed to minimize the number of bytes required per instruction: To do so, most of the addressing modes may be subdivided in two submodes called long and short:

- Long addressing mode is more powerful because it can use the full 64 Kbyte address space, however it uses more bytes and more CPU cycles.
- Short addressing mode is less powerful because it can generally only access page zero (0000h - 00FFh range), but the instruction size is more compact, and faster. All memory to memory instructions use short addressing modes only (CLR, CPL, NEG, BSET, BRES, BTJT, BTJF, INC, DEC, RLC, RRC, SLL, SRL, SRA, SWAP)

The ST7 Assembler optimizes the use of long and short addressing modes.

Table 36. ST7 addressing mode overview (1)

Mode		Syntax	Destination/ source	Pointer address	Pointer size	Length (bytes)
Inherent		nop				+ 0
Immediate		ld A,#\$55				+ 1
Short	Direct	ld A,\$10	00..FF			+ 1
Long	Direct	ld A,\$1000	0000..FFFF			+ 2
No Offset	Direct	Indexed	ld A,(X)	00..FF		+ 0 (with X register) + 1 (with Y register)
Short	Direct	Indexed	ld A,(\$10,X)	00..1FE		+ 1
Long	Direct	Indexed	ld A,(\$1000,X)	0000..FFFF		+ 2
Short	Indirect		ld A,[\$10]	00..FF	00..FF	byte + 2
Long	Indirect		ld A,[\$10.w]	0000..FFFF	00..FF	word + 2
Short	Indirect	Indexed	ld A,[@\$10,X]	00..1FE	00..FF	byte + 2

Table 36. ST7 addressing mode overview (continued)⁽¹⁾

Mode			Syntax	Destination/ source	Pointer address	Pointer size	Length (bytes)
Long	Indirect	Indexed	ld A, ([\$10.w],X)	0000..FFFF	00..FF	word	+ 2
Relative	Direct		jrne loop	PC-128/PC+127 ¹⁾			+ 1
Relative	Indirect		jrne [\$10]	PC-128/PC+127 ¹⁾	00..FF	byte	+ 2
Bit	Direct		bset \$10,#7	00..FF			+ 1
Bit	Indirect		bset [\$10],#7	00..FF	00..FF	byte	+ 2
Bit	Direct	Relative	btjt \$10,#7,skip	00..FF			+ 2
Bit	Indirect	Relative	btjt [\$10],#7,skip	00..FF	00..FF	byte	+ 3

1. At the time the instruction is executed, the Program Counter (PC) points to the instruction following JRxx.

11.1.1 Inherent mode

All Inherent instructions consist of a single byte. The opcode fully specifies all the required information for the CPU to process the operation.

Table 37. Instructions supporting inherent addressing mode

Inherent instruction	Function
NOP	No operation
TRAP	S/W Interrupt
WFI	Wait For Interrupt (low power mode)
HALT	Halt Oscillator (lowest power mode)
RET	Subroutine return
IRET	Interrupt subroutine return
SIM	Set interrupt mask
RIM	Reset interrupt mask
SCF	Set carry flag
RCF	Reset carry flag
RSP	Reset stack pointer
LD	Load
CLR	Clear
PUSH/POP	Push/Pop to/from the stack
INC/DEC	Increment/Decrement
TNZ	Test Negative or Zero
CPL, NEG	1 or 2 complement
MUL	Byte multiplication
SLL, SRL, SRA, RLC, RRC	Shift and rotate operations
SWAP	Swap nibbles

11.1.2 Immediate

Immediate instructions have 2 bytes, the first byte contains the opcode, the second byte contains the operand value.

Table 38. Instructions supporting inherent immediate addressing mode

Immediate instruction	Function
LD	Load
CP	Compare
BCP	Bit compare
AND, OR, XOR	Logical operations
ADC, ADD, SUB, SBC	Arithmetic operations

11.1.3 Direct

In Direct instructions, the operands are referenced by their memory address.

The direct addressing mode consists of two submodes:

Direct (short) addressing mode

the address is a byte, thus requires only 1 byte after the opcode, but only allows 00 - FF addressing space.

Direct (long) addressing mode

The address is a word, thus allowing 64 Kbyte addressing space, but requires 2 bytes after the opcode.

11.1.4 Indexed mode (no offset, short, long)

In this mode, the operand is referenced by its memory address, which is defined by the unsigned addition of an index register (X or Y) with an offset.

The indirect addressing mode consists of three submodes:

Indexed mode (no offset)

There is no offset (no extra byte after the opcode), and allows 00 - FF addressing space.

Indexed mode (short)

The offset is a byte, thus requires only 1 byte after the opcode and allows 00 - 1FE addressing space.

Indexed mode (long)

The offset is a word, thus allowing 64 Kbyte addressing space and requires 2 bytes after the opcode.

11.1.5 Indirect modes (short, long)

The required data byte to do the operation is found by its memory address, located in memory (pointer).

The pointer address follows the opcode. The indirect addressing mode consists of two submodes:

Indirect mode (short)

The pointer address is a byte, the pointer size is a byte, thus allowing 00 - FF addressing space, and requires 1 byte after the opcode.

Indirect mode (long)

The pointer address is a byte, the pointer size is a word, thus allowing 64 Kbyte addressing space, and requires 1 byte after the opcode.

11.1.6 Indirect indexed modes (short, long)

This is a combination of indirect and short indexed addressing modes. The operand is referenced by its memory address, which is defined by the unsigned addition of an index register value (X or Y) with a pointer value located in memory. The pointer address follows the opcode.

The indirect indexed addressing mode consists of two submodes:

Indirect indexed mode (short)

The pointer address is a byte, the pointer size is a byte, thus allowing 00 - 1FE addressing space, and requires 1 byte after the opcode.

Indirect indexed mode (long)

The pointer address is a byte, the pointer size is a word, thus allowing 64 Kbyte addressing space, and requires 1 byte after the opcode.

Table 39. Instructions supporting direct, indexed, indirect and indirect indexed addressing modes

Instructions	Function
Long and short instructions	
LD	Load
CP	Compare
AND, OR, XOR	Logical operations
ADC, ADD, SUB, SBC	Arithmetic addition/subtraction operations
BCP	Bit compare
Short instructions only	
CLR	Clear
INC, DEC	Increment/decrement
TNZ	Test negative or zero

Table 39. Instructions supporting direct, indexed, indirect and indirect indexed addressing modes (continued)

Instructions	Function
CPL, NEG	1 or 2 complement
BSET, BRES	Bit operations
BTJT, BTJF	Bit test and jump operations
SLL, SRL, SRA, RLC, RRC	Shift and rotate operations
SWAP	Swap nibbles
CALL, JP	Call or jump subroutine

11.1.7 Relative modes (direct, indirect)

This addressing mode is used to modify the PC register value by adding an 8-bit signed offset to it.

Table 40. Instructions supporting relative modes

Available relative direct/indirect instructions	Function
JRxx	Conditional jump
CALLR	Call relative

The relative addressing mode consists of two submodes:

Relative mode (Direct)

The offset follows the opcode

Relative mode (Indirect)

The offset is defined in memory, of which the address follows the opcode.

11.2 Instruction groups

The ST7 family devices use an Instruction Set consisting of 63 instructions. The instructions may be subdivided into 13 main groups as illustrated in the following table:

Table 41. ST7 instruction set

Load and Transfer	LD	CLR						
Stack operation	PUSH	POP	RSP					
Increment/Decrement	INC	DEC						
Compare and tests	CP	TNZ	BCP					
Logical operations	AND	OR	XOR	CPL	NEG			
Bit operation	BSET	BRES						
Conditional bit test and branch	BTJT	BTJF						
Arithmetic operations	ADC	ADD	SUB	SBC	MUL			

Table 41. ST7 instruction set (continued)

Shift and rotates	SLL	SRL	SRA	RLC	RRC	SWAP	SLA	
Unconditional jump or call	JRA	JRT	JRF	JP	CALL	CALLR	NOP	RET
Conditional branch	JRxx							
Interruptio management	TRAP	WFI	HALT	IRET				
Condition code flag modification	SIM	RIM	SCF	RCF				

Using a prebyte

The instructions are described with 1 to 4 bytes.

In order to extend the number of available opcodes for an 8-bit CPU (256 opcodes), three different prebyte opcodes are defined. These prebytes modify the meaning of the instruction they precede.

The whole instruction becomes:

- PC-2 End of previous instruction
- PC-1 Prebyte
- PC Opcode
- PC+1 Additional word (0 to 2) according to the number of bytes required to compute the effective address

These prebytes enable instruction in Y as well as indirect addressing modes to be implemented. They precede the opcode of the instruction in X or the instruction using direct addressing mode. The prebytes are:

- PDY 90 Replace an X based instruction using immediate, direct, indexed, or inherent addressing mode by a Y one.
- PIX 92 Replace an instruction using direct, direct bit or direct relative addressing mode to an instruction using the corresponding indirect addressing mode. It also changes an instruction using X indexed addressing mode to an instruction using indirect X indexed addressing mode.
- PiY 91 Replace an instruction using X indirect indexed addressing mode by a Y one.

11.2.1 Illegal opcode reset

In order to provide enhanced robustness to the device against unexpected behavior, a system of illegal opcode detection is implemented. If a code to be executed does not correspond to any opcode or prebyte value, a reset is generated. This, combined with the watchdog, allows the detection and recovery from an unexpected fault or interference.

Note: A valid prebyte associated with a valid opcode forming an unauthorized combination does not generate a reset.

Table 42. Illegal opcode detection

Mnemo	Description	Function/example	Dst	Src	H	I	N	Z	C
ADC	Add with carry	$A = A + M + C$	A	M	H	-	N	Z	C
ADD	Addition	$A = A + M$	A	M	H	-	N	Z	C
AND	Logical and	$A = A . M$	A	M	-	-	N	Z	-
BCP	Bit compare A, Memory	tst (A . M)	A	M	-	-	N	Z	-

Table 42. Illegal opcode detection (continued)

Mnemo	Description	Function/example	Dst	Src	H	I	N	Z	C
BRES	Bit Reset	bres Byte, #3	M	-	-	-	-	-	-
BSET	Bit Set	bset Byte, #3	M	-	-	-	-	-	-
BTJF	Jump if bit is false (0)	btjf Byte, #3, Jmp1	M	-	-	-	-	-	C
BTJT	Jump if bit is true (1)	btjt Byte, #3, Jmp1	M	-	-	-	-	-	C
CALL	Call subroutine		-	-	-	-	-	-	-
CALLR	Call subroutine relative		-	-	-	-	-	-	-
CLR	Clear		reg, M	-	-	-	0	1	-
CP	Arithmetic compare	tst(Reg - M)	reg	M	-	-	N	Z	C
CPL	One Complement	A = FFH-A	reg, M	-	-	-	N	Z	1
DEC	Decrement	dec Y	reg, M	-	-	-	N	Z	-
HALT	Halt		-	-	-	-	-	-	-
IRET	Interrupt routine return	Pop CC, A, X, PC	-	-	H	I	N	Z	C
INC	Increment	inc X	reg, M	-	-	-	N	Z	-
JP	Absolute jump	jp [TBL.w]	-	-	-	-	-	-	-
JRA	Jump relative always		-	-	-	-	-	-	-
JRT	Jump relative		-	-	-	-	-	-	-
JRF	Never jump	jrf *	-	-	-	-	-	-	-
JRIH	Jump if ext. interrupt = 1		-	-	-	-	-	-	-
JRIL	Jump if ext. interrupt = 0		-	-	-	-	-	-	-
JRH	Jump if H = 1	H = 1 ?	-	-	-	-	-	-	-
JRNH	Jump if H = 0	H = 0 ?	-	-	-	-	-	-	-
JRM	Jump if I = 1	I = 1 ?	-	-	-	-	-	-	-
JRNM	Jump if I = 0	I = 0 ?	-	-	-	-	-	-	-
JRMI	Jump if N = 1 (minus)	N = 1 ?	-	-	-	-	-	-	-
JRPL	Jump if N = 0 (plus)	N = 0 ?	-	-	-	-	-	-	-
JREQ	Jump if Z = 1 (equal)	Z = 1 ?	-	-	-	-	-	-	-
JRNE	Jump if Z = 0 (not equal)	Z = 0 ?	-	-	-	-	-	-	-
JRC	Jump if C = 1	C = 1 ?	-	-	-	-	-	-	-
JRNC	Jump if C = 0	C = 0 ?	-	-	-	-	-	-	-
JRULT	Jump if C = 1	Unsigned <	-	-	-	-	-	-	-
JRUGE	Jump if C = 0	Jmp if unsigned ≥	-	-	-	-	-	-	-
JRUGT	Jump if (C + Z = 0)	Unsigned >	-	-	-	-	-	-	-
JRULE	Jump if (C + Z = 1)	Unsigned ≤	-	-	-	-	-	-	-
LD	Load	dst ≤ src	reg, M	M, reg	-	-	N	Z	-
MUL	Multiply	X,A = X * A	A, X, Y	X, Y, A	0	-	-	-	0

Table 42. Illegal opcode detection (continued)

Mnemo	Description	Function/example	Dst	Src	H	I	N	Z	C
NEG	Negate (2's compl)	neg \$10	reg, M	-	-	-	N	Z	C
NOP	No operation		-	-	-	-	-	-	-
OR	OR operation	$A = A + M$	A	M	-	-	N	Z	-
POP	Pop from the stack	pop reg	reg	M	-	-	-	-	-
		pop CC	CC	M	H	I	N	Z	C
PUSH	Push onto the stack	push Y	M	reg, CC	-	-	-	-	-
RCF	Reset carry flag	$C = 0$	-	-	-	-	-	-	0
RET	Subroutine return		-	-	-	-	-	-	-
RIM	Enable Interrupts	$I = 0$	-	-	-	0	-	-	-
RLC	Rotate left true C	$C \leq Dst \leq C$	reg, M	-	-	-	N	Z	C
RRC	Rotate right true C	$C \geq Dst \geq C$	reg, M	-	-	-	N	Z	C
RSP	Reset Stack Pointer	$S = \text{Max allowed}$	-	-	-	-	-	-	-
SBC	Subtract with carry	$A = A - M - C$	A	M	-	-	N	Z	C
SCF	Set carry flag	$C = 1$	-	-	-	-	-	-	1
SIM	Disable interrupts	$I = 1$	-	-	-	1	-	-	-
SLA	Shift left arithmetic	$C \leq Dst \leq 0$	reg, M	-	-	-	N	Z	C
SLL	Shift left logic	$C \leq Dst \leq 0$	reg, M	-	-	-	N	Z	C
SRL	Shift right logic	$0 \geq Dst \geq C$	reg, M	-	-	-	0	Z	C
SRA	Shift right arithmetic	$Dst7 \geq Dst \geq C$	reg, M	-	-	-	N	Z	C
SUB	Subtraction	$A = A - M$	A	M	-	-	N	Z	C
SWAP	SWAP nibbles	$Dst[7..4] \leq Dst[3..0]$	reg, M	-	-	-	N	Z	-
TNZ	Test for Neg & Zero	tnz lbl1	-	-	-	-	N	Z	-
TRAP	S/W trap	S/W interrupt	-	-	-	1	-	-	-
WFI	Wait for interrupt		-	-	-	0	-	-	-
XOR	Exclusive OR	$A = A \text{ XOR } M$	A	M	-	-	N	Z	-

12 Electrical characteristics

12.1 Parameter conditions

Unless otherwise specified, all voltages are referred to V_{SS} .

12.1.1 Minimum and maximum values

Unless otherwise specified the minimum and maximum values are guaranteed in the worst conditions of ambient temperature, supply voltage and frequencies by tests in production on 100% of the devices with an ambient temperature at $T_A=25\text{ °C}$ and $T_A=T_{A\text{max}}$ (given by the selected temperature range).

Data based on characterization results, design simulation and/or technology characteristics are indicated in the table footnotes and are not tested in production. Based on characterization, the minimum and maximum values refer to sample tests and represent the mean value plus or minus three times the standard deviation (mean+3 σ).

12.1.2 Typical values

Unless otherwise specified, typical data are based on $T_A=25\text{ °C}$, $V_{DD}=5\text{ V}$ (for the $4.5\text{ V}\leq V_{DD}\leq 5.5\text{ V}$ voltage range), $V_{DD}=3.75\text{ V}$ (for the $3\text{ V}\leq V_{DD}\leq 4.5\text{ V}$ voltage range) and $V_{DD}=2.7\text{ V}$ (for the $2.4\text{ V}\leq V_{DD}\leq 3\text{ V}$ voltage range). They are given only as design guidelines and are not tested.

12.1.3 Typical curves

Unless otherwise specified, all typical curves are given only as design guidelines and are not tested.

12.1.4 Loading capacitor

The loading conditions used for pin parameter measurement are shown in [Figure 37](#).

Figure 37. Pin loading conditions

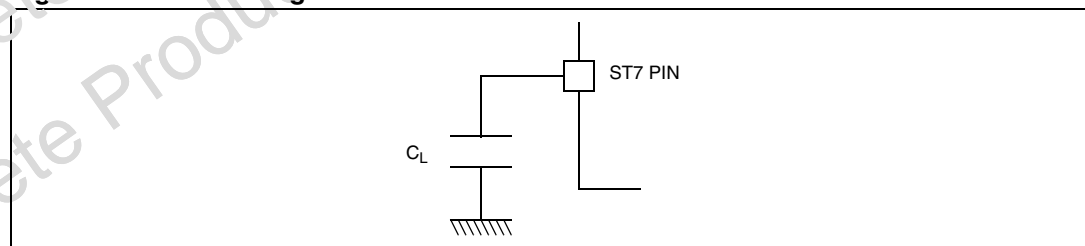

12.1.5 Pin input voltage

The input voltage measurement on a pin of the device is described in [Figure 38](#).

Figure 38. Pin input voltage

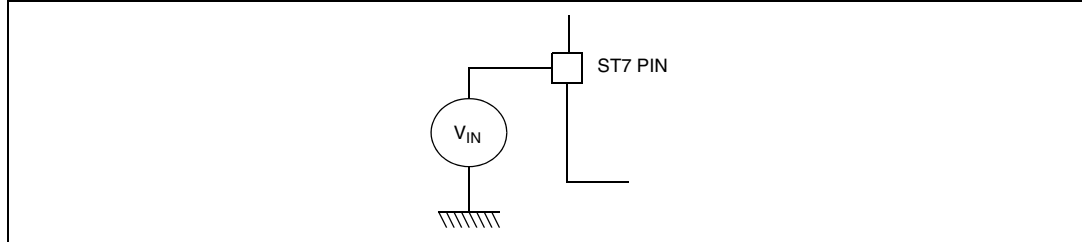

12.2 Absolute maximum ratings

Stresses above those listed as “absolute maximum ratings” may cause permanent damage to the device. This is a stress rating only and functional operation of the device under these conditions is not implied. Exposure to maximum rating conditions for extended periods may affect device reliability.

1. Directly connecting the I/O pins to V_{DD} or V_{SS} could damage the device if an unexpected change of the I/O configuration occurs (for example, due to a corrupted program counter). To guarantee safe operation, this connection has to be done through a pull-up or pull-down resistor (typical: 10 k Ω for I/Os). Unused I/O pins must be tied in the same way to V_{DD} or V_{SS} according to their reset configuration.

Table 43. Voltage characteristics

Symbol	Ratings	Maximum value	Unit
$V_{DD} - V_{SS}$	Supply voltage	7.0	V
V_{IN}	Input voltage on any pin ⁽¹⁾	$V_{SS}-0.3$ to $V_{DD}+0.3$	
$V_{ESD(HBM)}$	Electrostatic discharge voltage (Human Body Model)	see Section 12.7.2	
$V_{ESD(MM)}$	Electrostatic discharge voltage (Machine Model)	see Section 12.7.2	

1. $I_{INJ(PIN)}$ must never be exceeded. This is implicitly insured if V_{IN} maximum is respected. If V_{IN} maximum cannot be respected, the injection current must be limited externally to the $I_{INJ(PIN)}$ value. A positive injection is induced by $V_{IN} > V_{DD}$ while a negative injection is induced by $V_{IN} < V_{SS}$.

Table 44. Current characteristics

Symbol	Ratings	Maximum value	Unit
I_{VDD}	Total current into V_{DD} power lines (source) ⁽¹⁾	75	mA
I_{VSS}	Total current out of V_{SS} ground lines (sink) ⁽¹⁾	150	
I_{IO}	Output current sunk by any standard I/O and control pin	20	
	Output current sunk by any high sink I/O pin	40	
	Output current source by any I/Os and control pin	-25	
$I_{INJ(PIN)}$ ⁽²⁾⁽³⁾	Injected current on \overline{RESET} pin	± 5	
	Injected current on any other pin ⁽⁴⁾	± 5	
$\Sigma I_{INJ(PIN)}$ ⁽²⁾	Total injected current (sum of all I/O and control pins) ⁽⁴⁾	± 20	

- All power (V_{DD}) and ground (V_{SS}) lines must always be connected to the external supply.
- $I_{INJ(PIN)}$ must never be exceeded. This is implicitly insured if V_{IN} maximum is respected. If V_{IN} maximum cannot be respected, the injection current must be limited externally to the $I_{INJ(PIN)}$ value. A positive injection is induced by $V_{IN} > V_{DD}$ while a negative injection is induced by $V_{IN} < V_{SS}$.
- Negative injection disturbs the analog performance of the device. In particular, it induces leakage currents throughout the device including the analog inputs. To avoid any deleterious effects on the analog functions, care must be taken:
 - Analog input pins must have a negative injection less than 0.8 mA (assuming that the impedance of the analog voltage is lower than the specified limits)
 - Pure digital pins must have a negative injection less than 1.6 mA. In addition, it is recommended to inject the current as far as possible from the analog input pins.
- When several inputs are submitted to a current injection, the maximum $\Sigma I_{INJ(PIN)}$ is the absolute sum of the positive and negative injected currents (instantaneous values). These results are based on characterisation with $\Sigma I_{INJ(PIN)}$ maximum current injection on four I/O port pins of the device.

Table 45. Thermal characteristics

Symbol	Ratings	value	Unit
T_{STC}	Storage temperature range	-65 to +150	°C
T_J	Maximum junction temperature (see Section 13: Package characteristics)		

12.3 Operating conditions

12.3.1 General operating conditions

$T_A = -40$ to $+125$ °C unless otherwise specified.

Table 46. General operating conditions

Symbol	Parameter	Conditions	Min	Max	Unit
V_{DD}	Supply voltage	$f_{CPU} = 4$ MHz max.	2.4	5.5	V
		$f_{CPU} = 8$ MHz max.	3.3	5.5	
f_{CPU}	CPU clock frequency	$3.3 V \leq V_{DD} \leq 5.5 V$	up to 8		MHz
		$2.4 V \leq V_{DD} < 3.3 V$	up to 4		

Figure 39. f_{CPU} maximum operating frequency versus V_{DD} supply voltage

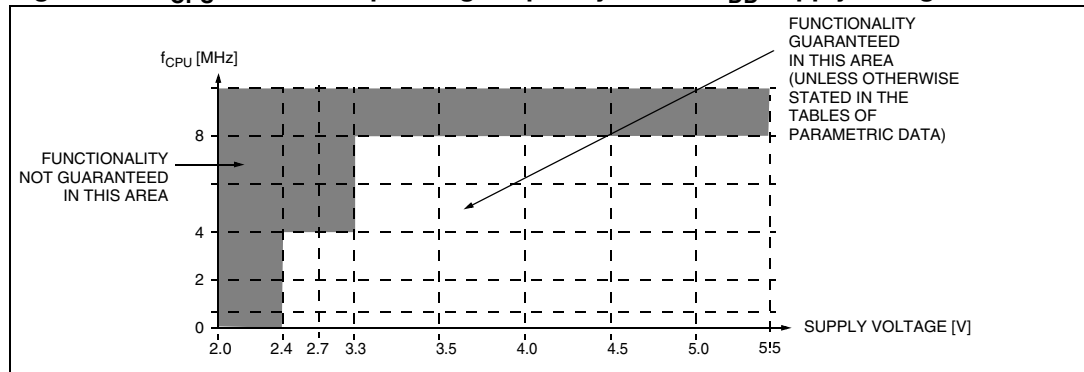

12.3.2 Operating conditions with low voltage detector (LVD)

$T_A = -40$ to 125 °C, unless otherwise specified

Table 47. Operating characteristics with LVD

Symbol	Parameter	Conditions	Min	Typ	Max	Unit
$V_{IT+(LVD)}$	Reset release threshold (V_{DD} rise)	High threshold	3.9	4.2	4.5	V
		Med. threshold	3.2	3.5	3.8	
		Low threshold	2.5	2.7	3.0	
$V_{IT-(LVD)}$	Reset generation threshold (V_{DD} fall)	High threshold	3.7	4.0	4.3	V
		Med. threshold	3.0	3.3	3.6	
		Low threshold	2.4	2.6	2.9	
V_{hys}	LVD voltage threshold hysteresis	$V_{IT+(LVD)} - V_{IT-(LVD)}$		150		mV
V_{tPOR}	V_{DD} rise time rate ⁽¹⁾⁽²⁾		20			$\mu\text{s/V}$
$I_{DD(LVD)}^{(3)}$	LVD/ V_{DD} current consumption	$V_{DD} = 5\text{ V}$		220		μA

- Not tested in production. The V_{DD} rise time rate condition is needed to ensure a correct device power-on and LVD reset release. When the V_{DD} slope is outside these values, the LVD may not release properly the reset of the MCU
- Use of LVD with capacitive power supply: with this type of power supply, if power cuts occur in the application, it is recommended to pull V_{DD} down to 0V to ensure optimum restart conditions. Refer to circuit example in [Figure 61 on page 114](#).
- Not tested in production.

12.3.3 Auxiliary voltage detector (AVD) thresholds

$T_A = -40$ to 125°C , unless otherwise specified.

Table 48. Operating characteristics with AVD⁽¹⁾

Symbol	Parameter	Conditions	Min ⁽²⁾	Typ ⁽²⁾	Max ⁽²⁾	Unit
$V_{IT+(AVD)}$	1 => 0 AVDF flag toggle threshold (V_{DD} rise)	High threshold	4.0	4.4	4.8	V
		Med. threshold	3.4	3.7	4.1	
		Low threshold	2.6	2.9	3.2	
$V_{IT-(AVD)}$	0 => 1 AVDF flag toggle threshold (V_{DD} fall)	High threshold	3.9	4.3	4.7	V
		Med. threshold	3.3	3.6	4.0	
		Low threshold	2.5	2.8	3.1	
V_{hys}	AVD voltage threshold hysteresis	$V_{IT+(AVD)} - V_{IT-(AVD)}$		150		mV

1. Refer to [Section : Monitoring the VDD main supply](#).

2. Not tested in production, guaranteed by characterization.

Table 49. Voltage drop between AVD flag set and LVD reset generation

Parameter	Min ⁽¹⁾	Typ ⁽¹⁾	Max ⁽¹⁾	Unit
AVD med. threshold - AVD low. threshold	800	850	950	mV
AVD high. threshold - AVD low threshold	1400	1450	1550	
AVD high. threshold - AVD med. threshold	600	650	750	
AVD low threshold - LVD low threshold	100	200	250	
AVD med. threshold - LVD low threshold	950	1050	1150	
AVD med. threshold - LVD med. threshold	250	300	400	
AVD high. threshold - LVD low threshold	1600	1700	1800	
AVD high. threshold - LVD med. threshold	900	1000	1050	

1. Not tested in production, guaranteed by characterization.

12.3.4 Internal RC oscillator

To improve clock stability and frequency accuracy, it is recommended to place a decoupling capacitor, typically 100 nF, between the V_{DD} and V_{SS} pins as close as possible to the ST7 device.

Internal RC oscillator calibrated at 5.0 V

The ST7 internal clock can be supplied by an internal RC oscillator (selectable by option byte).

Table 50. Internal RC oscillator characteristics (5.0 V calibration)

Symbol	Parameter	Conditions	Min	Typ	Max	Unit
f_{RC}	Internal RC oscillator frequency	RCCR = FF (reset value), $T_A = 25\text{ }^\circ\text{C}$, $V_{DD} = 5\text{ V}$		4.4		MHz
		RCCR = RCCR0 ⁽¹⁾ , $T_A = 25\text{ }^\circ\text{C}$, $V_{DD} = 5\text{ V}$		8		
ACC_{RC}	Accuracy of internal RC oscillator with RCCR=RCCR0 ⁽¹⁾	$T_A = 25\text{ }^\circ\text{C}$, $V_{DD} = 4.5\text{ to }5.5\text{ V}$ ⁽²⁾	-2.0		+2.0	%
		$T_A = 0\text{ to }+85\text{ }^\circ\text{C}$, $V_{DD} = 4.5\text{ to }5.5\text{ V}$ ⁽²⁾	-2.5		+4.0	%
		$T_A = 0\text{ to }+125\text{ }^\circ\text{C}$, $V_{DD} = 4.5\text{ to }5.5\text{ V}$ ⁽²⁾	-3.0		+5.0	%
		$T_A = -40\text{ }^\circ\text{C to }0\text{ }^\circ\text{C}$, $V_{DD} = 4.5\text{ to }5.5\text{ V}$ ⁽²⁾	-4.0		+2.5	%
$t_{su(RC)}$	RC oscillator setup time	$T_A = 25\text{ }^\circ\text{C}$, $V_{DD} = 5\text{ V}$		4 ⁽²⁾		μs

1. See [Section 6.2: Internal RC oscillator adjustment](#)

2. Tested in production at 5.0 V only

Internal RC oscillator calibrated at 3.3 V

The ST7 internal clock can be supplied by an internal RC oscillator (selectable by option byte).

Table 51. Internal RC oscillator characteristics (3.3 V calibration)

Symbol	Parameter	Conditions	Min	Typ	Max	Unit
f_{RC}	Internal RC oscillator frequency	RCCR = FF (reset value), $T_A = 25\text{ }^\circ\text{C}$, $V_{DD} = 3.3\text{ V}$		4.3		MHz
		RCCR = RCCR1 ⁽¹⁾ , $T_A = 25\text{ }^\circ\text{C}$, $V_{DD} = 3.3\text{ V}$		8		
ACC_{RC}	Accuracy of internal RC oscillator with RCCR=RCCR1 ⁽¹⁾	$T_A = 25\text{ }^\circ\text{C}$, $V_{DD} = 3.0\text{ to }3.6\text{ V}$ ⁽²⁾	-1.0		+1.0	%
		$T_A = 0\text{ to }+85\text{ }^\circ\text{C}$, $V_{DD} = 3.0\text{ to }3.6\text{ V}$ ⁽²⁾	-2.5		+4.0	%
		$T_A = 0\text{ to }+125\text{ }^\circ\text{C}$, $V_{DD} = 3.0\text{ to }3.6\text{ V}$ ⁽²⁾	-3.0		+5.0	%
		$T_A = -40\text{ }^\circ\text{C to }0\text{ }^\circ\text{C}$, $V_{DD} = 3.0\text{ to }3.6\text{ V}$ ⁽²⁾	-4.0		+2.5	%
$t_{su(RC)}$	RC oscillator setup time	$T_A = 25\text{ }^\circ\text{C}$, $V_{DD} = 3.3\text{ V}$		4 ⁽²⁾		μs

1. See [Section 6.2: Internal RC oscillator adjustment](#)

2. Tested in production at 3.3 V only

Figure 40. Typical accuracy with RCCR=RCCR0 vs V_{DD} = 2.4-6.0 V and temperature

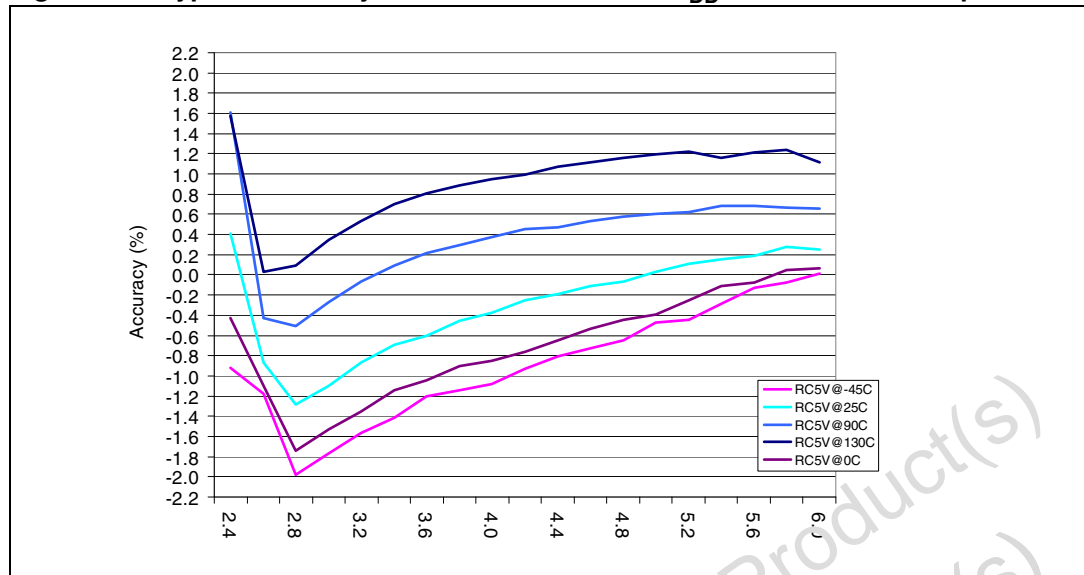
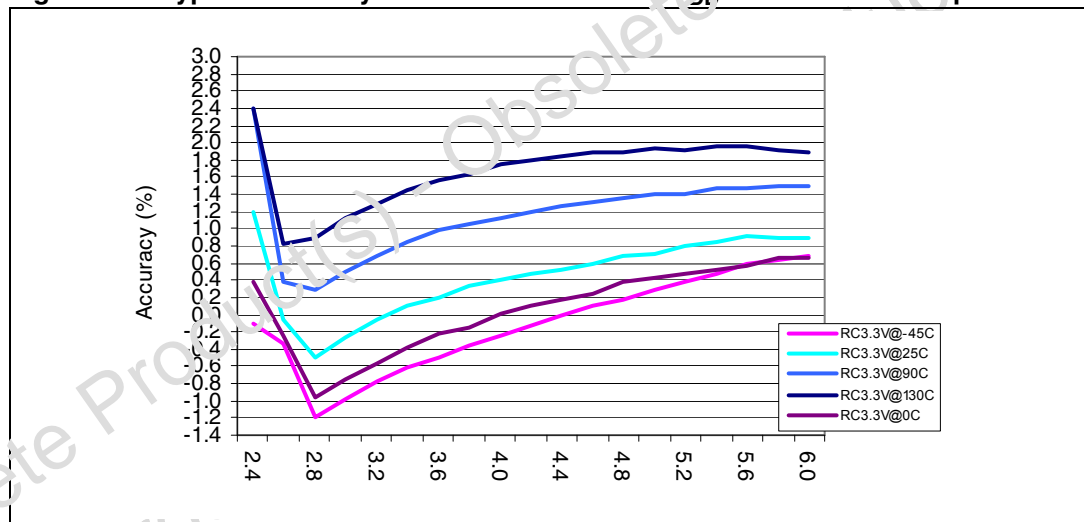

Figure 41. Typical accuracy with RCCR=RCCR1 vs V_{DD} = 2.4-6.0V and temperature



12.4 Supply current characteristics

The following current consumption specified for the ST7 functional operating modes over temperature range does not take into account the clock source current consumption. To get the total device consumption, the two current values must be added (except for Halt mode for which the clock is stopped). Refer to [Section 12.4.2: Internal RC oscillator supply current characteristics](#).

T_A = -40 to +125 °C unless otherwise specified.

12.4.1 Supply current

Table 52. Supply current characteristics

Symbol	Parameter	Conditions	Typ	Max	Unit	
I _{DD}	Supply current in Run mode ⁽¹⁾	f _{CPU} = 4 MHz	2.5	4.5 ⁽²⁾	mA	
		f _{CPU} = 8 MHz	5.0	7.5		
	Supply current in Wait mode ⁽³⁾	f _{CPU} = 4 MHz	0.85	2.0 ⁽²⁾		
		f _{CPU} = 8 MHz	1.2	3.5		
	Supply current in Wait mode ⁽⁴⁾	f _{CPU} /32 = 250 kHz	600	950	μA	
	Supply current in Slow-Wait mode ⁽⁵⁾	f _{CPU} /32 = 250 kHz	450	750		
	Supply current in AWUFH mode ⁽⁶⁾⁽⁷⁾		45	100 ⁽²⁾		
	Supply current in Active-halt mode		100	250		
	Supply current in Halt mode ⁽⁸⁾	T _A = 85 °C	0.5	3.0		
		T _A = 125 °C	0.5	5.0		
	I _{DD}	Supply current in Run mode ⁽¹⁾	f _{CPU} = 4 MHz	1.30	2.0 ⁽²⁾	mA
			f _{CPU} = 4 MHz	0.36	0.5 ⁽²⁾	
		Supply current in Wait mode ⁽³⁾	f _{CPU} /32 = 250 kHz	300	400 ⁽²⁾	μA
			f _{CPU} /32 = 250 kHz	250	350 ⁽²⁾	
Supply current in Slow mode ⁽⁴⁾			20	50 ⁽²⁾		
Supply current in Active-halt mode			90	150 ⁽²⁾		
Supply current in Halt mode ⁽⁸⁾		T _A = 85 °C	0.25	2.5 ⁽²⁾		
		T _A = 125 °C	0.25	4.5 ⁽²⁾		

- CPU running with memory access, all I/O pins in input mode with a static value at V_{DD} or V_{SS} (no load), all peripherals in reset state; clock input (CLKIN) driven by external square wave, LVD disabled.
- Data based on characterization, not tested in production.
- All I/O pins in input mode with a static value at V_{DD} or V_{SS} (no load), all peripherals in reset state; clock input (CLKIN) driven by external square wave, LVD disabled.
- All I/O pins in input mode with a static value at V_{DD} or V_{SS} (no load), all peripherals in reset state; clock input (CLKIN) driven by external square wave, LVD disabled.
- Slow-Wait mode selected with f_{CPU} based on f_{OSC} divided by 32. All I/O pins in input mode with a static value at V_{DD} or V_{SS} (no load), all peripherals in reset state; clock input (CLKIN) driven by external square wave, LVD disabled.
- All I/O pins in input mode with a static value at V_{DD} or V_{SS} (no load). Data tested in production at V_{DD} max. and f_{CPU} max.
- This consumption refers to the Halt period only and not the associated run period which is software dependent.
- All I/O pins in output mode with a static value at V_{SS} (no load), LVD disabled. Data based on characterization results, tested in production at V_{DD} max and f_{CPU} max.

12.4.2 Internal RC oscillator supply current characteristics

Table 53. Internal RC oscillator supply current

Symbol	Parameter	Conditions	Min	Typ	Max ⁽¹⁾	Unit	
I _{DD}	Supply current in Run mode ⁽²⁾	RC oscillator calibrated at 5.0V	T _A =25 °C, int RC = 4 MHz		3.2	5.5	mA
			T _A =25 °C, int RC = 8 MHz		5.7	8.5	
			T _A =25 °C, AWU RC		0.13	0.2	
	Supply current in Wait mode ⁽³⁾		T _A =25 °C, int RC = 4 MHz		1.5	3.0	
			T _A =25 °C, int RC = 8 MHz		1.9	4.5	
	Supply current in Slow mode ⁽⁴⁾		T _A =25 °C, int RC/32 = 250 kHz		1.3	2.0	
	Supply current in Slow-Wait mode ⁽⁵⁾		T _A =25 °C, int RC/32 = 250 kHz		1.1	1.9	
Supply current in Active-halt mode			0.8	1.25			
I _{DD}	Supply current in Run mode ⁽²⁾	RC oscillator calibrated at 3.3V	T _A =25 °C, int RC = 4 MHz		2.0	3.0	mA
			T _A =25 °C, int RC = 2 MHz		1.3	2.0	
			T _A =25 °C, AWU RC		0.1	0.18	
	Supply current in Wait mode ⁽³⁾		T _A =25 °C, int RC = 4 MHz		1.0	1.6	
			T _A =25 °C, int RC = 2 MHz		0.9	1.5	
	Supply current in Slow mode ⁽⁴⁾		T _A =25 °C, int RC/32 = 250 kHz		0.95	1.5	
	Supply current in Slow-Wait mode ⁽⁵⁾		T _A =25 °C, int RC/32 = 250 kHz		0.85	1.4	
Supply current in Active-halt mode			0.8	1.3			

1. Data based on characterization results, not tested in production.
2. CPU running with memory access, all I/O pins in input mode with a static value at V_{DD} or V_{SS} (no load), all peripherals in reset state; CPU clock provided by the internal RC, LVD disabled.
3. All I/O pins in input mode with a static value at V_{DD} or V_{SS} (no load), all peripherals in reset state; CPU clock provided by the internal RC, LVD disabled.
4. Slow mode selected with f_{CPU} based on f_{OSC} divided by 32. All I/O pins in input mode with a static value at V_{DD} or V_{SS} (no load), all peripherals in reset state; CPU clock provided by the internal RC, LVD disabled.
5. Slow-Wait mode selected with f_{CPU} based on f_{OSC} divided by 32. All I/O pins in input mode with a static value at V_{DD} or V_{SS} (no load), all peripherals in reset state; CPU clock provided by the internal RC, LVD disabled.

Figure 42. Typical I_{DD} in run mode vs. internal clock frequency and V_{DD}

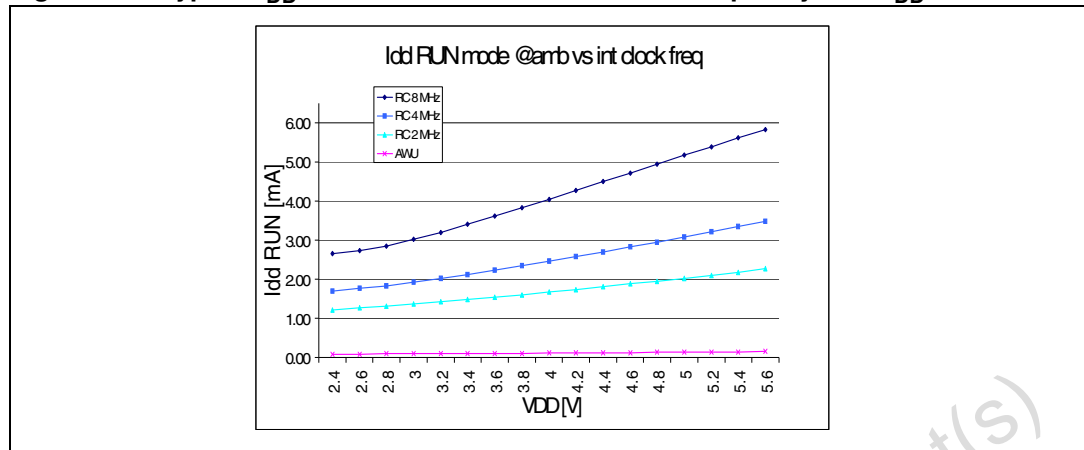

Figure 43. Typical I_{DD} in WFI mode vs. internal clock frequency and V_{DD}

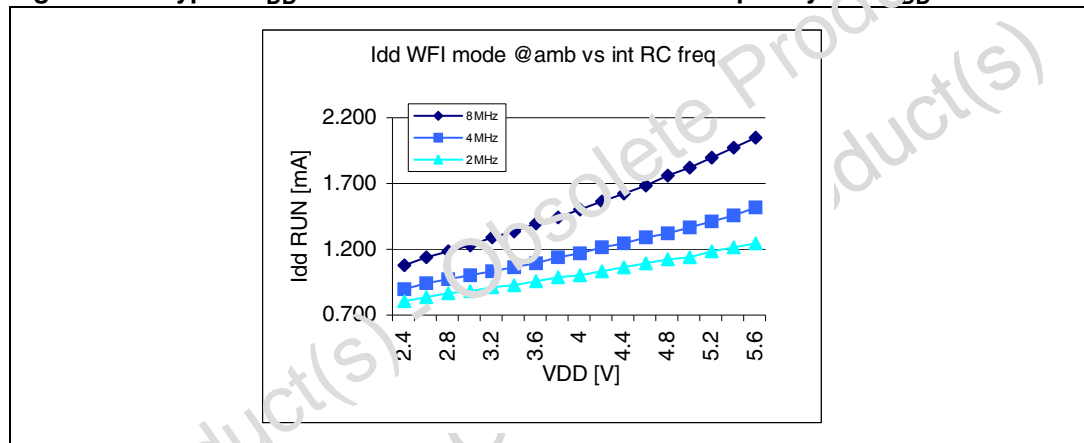

Figure 44. Typical I_{DD} in Slow, Slow-wait and Active-halt mode vs V_{DD} & int RC = 8 MHz

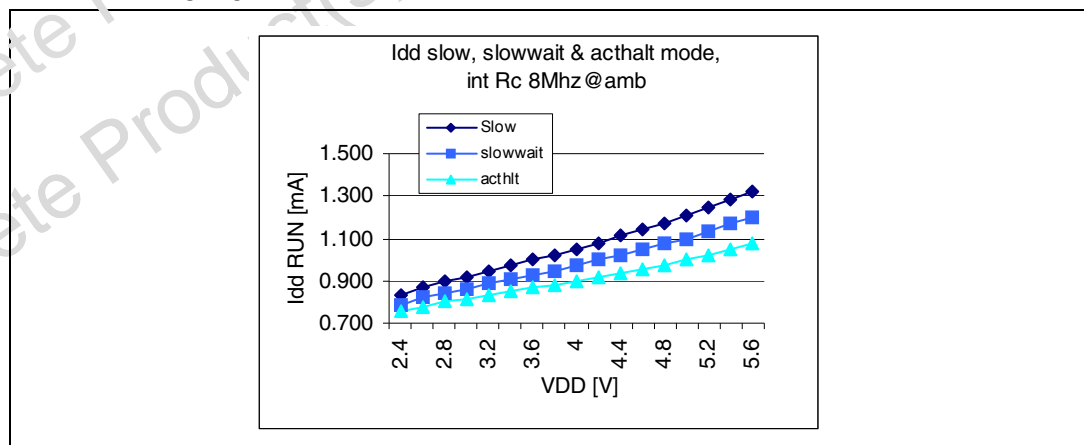

Figure 45. I_{DD} vs temp @ V_{DD} 5 V & int RC = 8 MHz

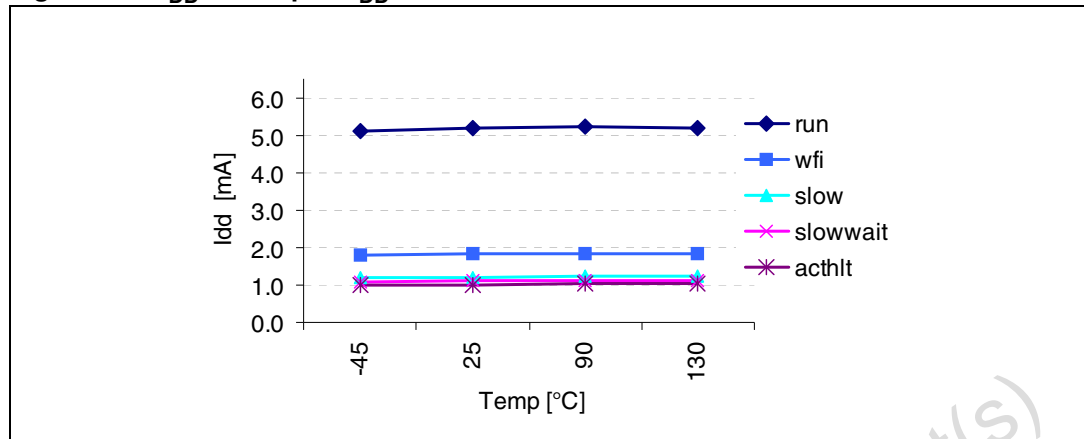

Figure 46. I_{DD} vs temp @ V_{DD} 5 V & int RC = 4 MHz

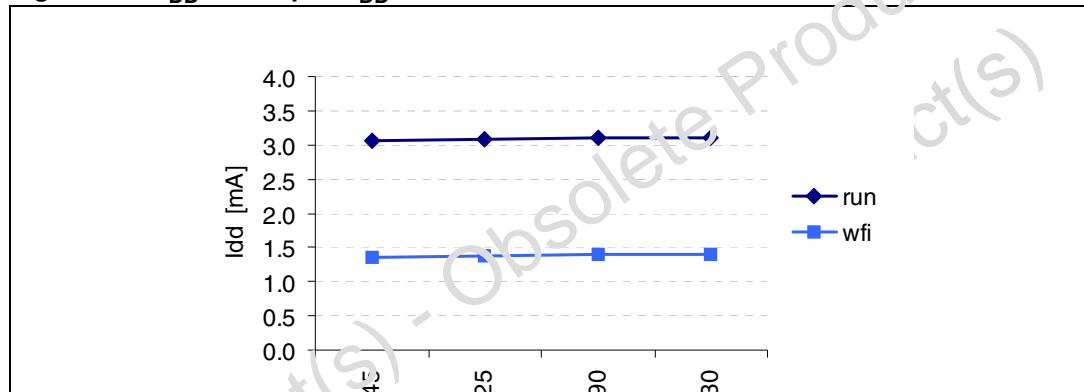
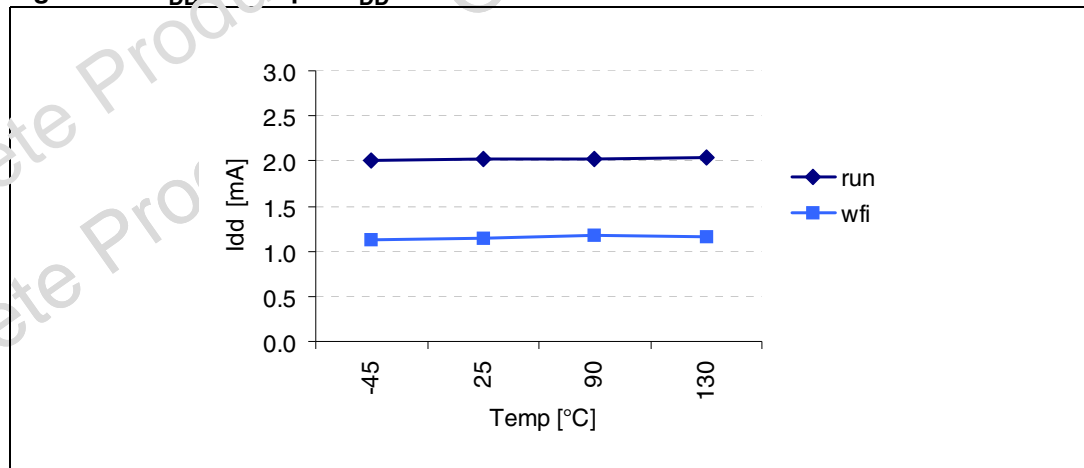

Figure 47. I_{DD} vs temp @ V_{DD} 5 V & int RC = 2 MHz



12.4.3 On-chip peripherals

Table 54. On-chip peripheral characteristics

Symbol	Parameter	Conditions		Typ ⁽¹⁾	Unit
I _{DD(AT)}	12-bit auto-reload timer supply current ⁽²⁾	f _{CPU} = 4 MHz	V _{DD} = 3.0 V	15	μA
		f _{CPU} = 8 MHz	V _{DD} = 5.0 V	30	
I _{DD(ADC)}	ADC supply current when converting ⁽³⁾	f _{ADC} = 2 MHz	V _{DD} = 3.0 V	450	
		f _{ADC} = 4 MHz	V _{DD} = 5.0 V	750	

1. Not tested in production, guaranteed by characterization.
2. Data based on a differential I_{DD} measurement between reset configuration (timer stopped) and the timer running in PWM mode at f_{CPU} = 8 MHz.
3. Data based on a differential I_{DD} measurement between reset configuration and continuous A/D conversions with amplifiers off.

12.5 Clock and timing characteristics

Subject to general operating conditions for V_{DD}, f_{OSC}, and T_A.

Table 55. General timings

Symbol	Parameter ⁽¹⁾	Conditions	Min	Typ ⁽²⁾	Max	Unit
t _{c(INST)}	Instruction cycle time	f _{CPU} = 8 MHz	2	3	12	t _{CPU}
			250	375	1500	ns
t _{v(IT)}	Interrupt reaction time ⁽³⁾ t _{v(IT)} = Δt _{c(INST)} + 10	f _{CPU} = 8 MHz	10		22	t _{CPU}
			1.25		2.75	μs

1. Data based on characterization. Not tested in production.
2. Data based on typical application software.
3. Time measured between interrupt event and interrupt vector fetch. Δt_{c(INST)} is the number of t_{CPU} cycles needed to finish the current instruction execution.

Table 56. Auto-wakeup RC oscillator

Parameter	Conditions	Min	Typ	Max	Unit
Supply Voltage Range		2.4	5.0	5.5	V
Operating Temperature Range		-40	25	125	°C
Current Consumption ⁽¹⁾	Without prescaler	2.0	8.0	14.0	μA
Consumption ⁽¹⁾	AWU RC switched off		0		μA
Output Frequency ⁽¹⁾		20	33	60	kHz

1. Data guaranteed by design.

12.6 Memory characteristics

$T_A = -40$ to 125 °C, unless otherwise specified;

Table 57. RAM and Hardware registers

Symbol	Parameter	Conditions	Min	Typ	Max	Unit
V_{RM}	Data retention mode ¹⁾	Halt mode (or Reset)	1.6			V

Table 58. Flash Program memory

Symbol	Parameter	Conditions	Min	Typ	Max	Unit
V_{DD}	Operating voltage for Flash write/erase		2.4 ⁽¹⁾		5.5	V
t_{prog}	Programming time for 1~32 bytes ⁽²⁾	$T_A = -40$ to $+125$ °C		5	10	ms
	Programming time for 1 kByte	$T_A = +25$ °C		0.10	0.32	s
t_{RET}	Data retention ⁽³⁾	$T_A = +55$ °C ⁽⁴⁾	20			years
N_{RW}	Write erase cycles	$T_A = +25$ °C	10k ⁽⁵⁾			cycles
I_{DD}	Supply current ⁽⁶⁾	Read / Write / Erase modes $t_{CLK} = 8$ MHz, $V_{DD} = 5.5$ V			2.6	mA
		No Read/No Write Mode			100	μA
		Power down mode / Halt		0	0.1	μA

1. Minimum V_{DD} supply voltage without losing data stored in RAM (in Halt mode or under reset) or in hardware registers (only in Halt mode). Guaranteed by construction, not tested in production.
2. Up to 32 bytes can be programmed at a time.
3. Data based on reliability test results and monitored in production.
4. The data retention time increases when the T_A decreases.
5. Design target value pending full product characterization.
6. Guaranteed by Design. Not tested in production.

12.7 EMC characteristics

Susceptibility tests are performed on a sample basis during product characterization.

12.7.1 Functional EMS (electromagnetic susceptibility)

Based on a simple running application on the product (toggling 2 LEDs through I/O ports), the product is stressed by two electromagnetic events until a failure occurs (indicated by the LEDs).

- **ESD:** Electrostatic discharge (positive and negative) is applied on all pins of the device until a functional disturbance occurs. This test conforms with the IEC 1000-4-2 standard.
- **FTB:** A Burst of Fast Transient voltage (positive and negative) is applied to V_{DD} and V_{SS} through a 100 pF capacitor, until a functional disturbance occurs. This test conforms with the IEC 1000-4-4 standard.

A device reset allows normal operations to be resumed. The test results are given in the table below based on the EMS levels and classes defined in application note AN1709.

Designing hardened software to avoid noise problems

EMC characterization and optimization are performed at component level with a typical application environment and simplified MCU software. It should be noted that good EMC performance is highly dependent on the user application and the software in particular.

Therefore it is recommended that the user applies EMC software optimization and prequalification tests in relation with the EMC level requested for his application.

Software recommendations

The software flowchart must include the management of runaway conditions such as:

- Corrupted program counter
- Unexpected reset
- Critical Data corruption (control registers...)

Pre-qualification trials

Most of the common failures (unexpected reset and program counter corruption) can be reproduced by manually forcing a low state on the $\overline{\text{RESET}}$ pin or the Oscillator pins for 1 second.

To complete these trials, ESD stress can be applied directly on the device, over the range of specification values. When unexpected behavior is detected, the software can be hardened to prevent unrecoverable errors occurring (see application note AN1015).

Table 59. EMC characteristics

Symbol	Parameter	Conditions	Level/class
V_{FESD}	Voltage limits to be applied on any I/O pin to induce a functional disturbance	$V_{DD}=5\text{ V}$, $T_A=+25\text{ °C}$, $f_{OSC}=8\text{ MHz}$, SO8 package, conforms to IEC 1000-4-2	3B
V_{FFTB}	Fast transient voltage burst limits to be applied through 100 pF on V_{DD} and V_{SS} pins to induce a functional disturbance	$V_{DD}=5\text{ V}$, $T_A=+25\text{ °C}$, $f_{OSC}=8\text{ MHz}$, SO8 package, conforms to IEC 1000-4-4	4B

12.7.2 Electromagnetic Interference (EMI)

Based on a simple application running on the product (toggling 2 LEDs through the I/O ports), the product is monitored in terms of emission. This emission test is in line with the norm SAE J 1752/3 which specifies the board and the loading of each pin.

Table 60. EMI characteristics⁽¹⁾

Symbol	Parameter	Conditions	Monitored frequency band	Max vs. [f _{osc} /f _{CPU}]	Unit
				-/8 MHz	
S _{EMI}	Peak level	V _{DD} =5 V, T _A =+25 °C, SO8 package, conforming to SAE J 1752/3	0.1 MHz to 30 MHz	21	dBμV
			30 MHz to 130 MHz	23	
			130 MHz to 1 GHz	10	
			SAE EMI Level	3	

1. Data based on characterization results, not tested in production.

12.7.3 Absolute maximum ratings (electrical sensitivity)

Based on three different tests (ESD, LU and DLU) using specific measurement methods, the product is stressed in order to determine its performance in terms of electrical sensitivity. For more details, refer to the application note AN1181.

Electrostatic discharge (ESD)

Electrostatic discharges (a positive then a negative pulse separated by 1 second) are applied to the pins of each sample according to each pin combination. The sample size depends on the number of supply pins in the device (3 parts*(n+1) supply pin). One model can be simulated: Human Body Model. This test conforms to the JESD22-A114A/A115A standard.

Table 61. Absolute maximum ratings

Symbol	Ratings	Conditions	Maximum value ⁽¹⁾	Unit
V _{ESD(HBM)}	Electrostatic discharge voltage (human body model)	T _A =+25°C	> 4000	V

1. Data based on characterization results, not tested in production.

Static and dynamic latchup

- **LU:** 3 complementary static tests are required on 10 parts to assess the latchup performance. A supply overvoltage (applied to each power supply pin) and a current injection (applied to each input, output and configurable I/O pin) are performed on each sample. This test conforms to the EIA/JESD 78 IC latchup standard. For more details, refer to the application note AN1181.
- **DLU:** Electrostatic discharges (one positive then one negative test) are applied to each pin of 3 samples when the micro is running to assess the latchup performance in

dynamic mode. Power supplies are set to the typical values, the oscillator is connected as near as possible to the pins of the micro and the component is put in reset mode. This test conforms to the IEC1000-4-2 and SAEJ1752/3 standards. For more details, refer to the application note AN1181.

Table 62. Electrical sensitivities

Symbol	Parameter	Conditions	Class ⁽¹⁾
LU	Static latchup class	$T_A=+125\text{ °C}$	A
DLU	Dynamic latchup class	$V_{DD}=5.5\text{ V}$, $f_{OSC}=4\text{ MHz}$, $T_A=+25\text{ °C}$	A

1. Class description: A Class is an STMicroelectronics internal specification. All its limits are higher than the JEDEC specifications, that means when a device belongs to Class A it exceeds the JEDEC standard. Class strictly covers all the JEDEC criteria (international standard).

12.8 I/O port pin characteristics

12.8.1 General characteristics

Subject to general operating conditions for V_{DD} , f_{OSC} , and T_A unless otherwise specified.

Table 63. General characteristics

Symbol	Parameter	Conditions	Min	Typ	Max	Unit
V_{IL}	Input low level voltage	-40°C to 125°C			$0.3V_{DD}$	V
V_{IH}	Input high level voltage		$0.7V_{DD}$			
V_{hys}	Schmitt trigger voltage hysteresis ⁽¹⁾			400		mV
I_L	Input leakage current	$V_{SS} \leq V_{IN} \leq V_{DD}$			± 1	μA
I_S	Static current consumption induced by each floating input pin ⁽²⁾	Floating input mode		100		
R_{PU}	Weak pull-up equivalent resistor ⁽³⁾ (4)	$V_{IN} = V_S$ S	$V_{DD} = 5 V$ $V_{DD} = 3 V$	80 200 ⁽¹⁾	120 170	k Ω
C_{IO}	I/O pin capacitance			5		pF
$t_{r(I/O)out}$	Output high to low level fall time ¹⁾	$C_L = 50 pF$ Between 10% and 90%		25		ns
$t_{r(I/O)out}$	Output low to high level rise time ¹⁾			25		
$t_{w(IT)in}$	External interrupt pulse time ⁽⁵⁾		1			t_{CPU}

1. Data based on characterization results, not tested in production.
2. Configuration not recommended, all unused pins must be kept at a fixed voltage: using the output mode of the I/O for example or an external pull-up or pull-down resistor (see [Figure 48](#)). Static peak current value taken at a fixed V_{IN} value, based on design simulation and technology characteristics, not tested in production. This value depends on V_{DD} and temperature values.
3. The R_{PU} pull-up equivalent resistor is based on a resistive transistor (corresponding I_{PU} current characteristics described in [Figure 49](#)).
4. R_{PU} not applicable on PA3 because it is multiplexed on \overline{RESET} pin
5. To generate an external interrupt, a minimum pulse width has to be applied on an I/O port pin configured as an external interrupt source.

Figure 48. Two typical applications with unused I/O pin

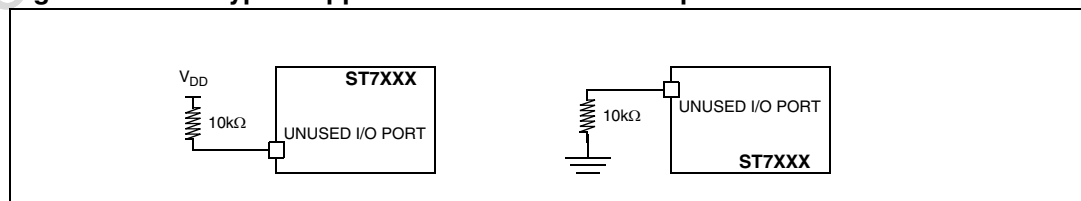

1. **Caution:** During normal operation the ICCCLK pin must be pulled-up, internally or externally (external pull-up of 10k mandatory in noisy environment). This is to avoid entering I²C mode unexpectedly during a reset.
2. I/O can be left unconnected if it is configured as output (0 or 1) by the software. This has the advantage of greater EMC robustness and lower cost.

Figure 49. Typical I_{PU} vs. V_{DD} with $V_{IN}=V_{SS}$

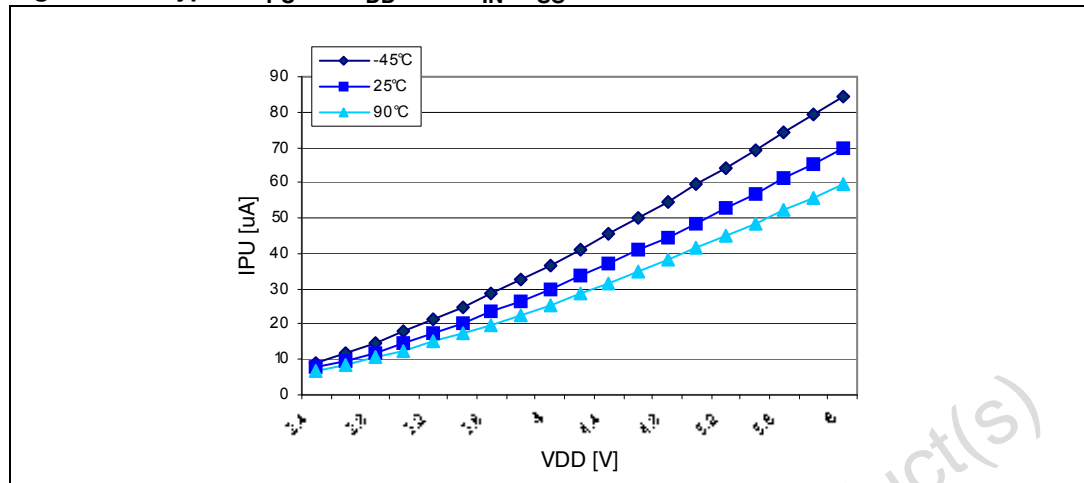

12.8.2 Output driving current characteristics

Subject to general operating conditions for V_{DD} , f_{CPU} , and T_A unless otherwise specified.

Table 64. Output driving current characteristics

Symbol	Parameter	Conditions	Min	Max	Unit
$V_{OL}^{(1)}$	Output low level voltage for PA3/RESET standard I/O pin (see Figure 52)	$I_{IO} = +5 \text{ mA}, T_A \leq 125 \text{ }^\circ\text{C}$		1200	mV
		$I_{IO} = +2 \text{ mA}, T_A \leq 125 \text{ }^\circ\text{C}$		400	
	Output low level voltage for a high sink I/O pin when 4 pins are sunk at same time (see Figure 55)	$I_{IO} = +20 \text{ mA}, T_A \leq 125 \text{ }^\circ\text{C}$		1300	
		$I_{IO} = +8 \text{ mA}, T_A \leq 125 \text{ }^\circ\text{C}$		750	
$V_{OH}^{(2)}$	Output high level voltage for an I/O pin when 4 pins are sourced at same time (see Figure 58)	$I_{IO} = -5 \text{ mA}, T_A \leq 125 \text{ }^\circ\text{C}$	$V_{DD}-1500$		
		$I_{IO} = -2 \text{ mA}, T_A \leq 125 \text{ }^\circ\text{C}$	$V_{DD}-800$		
$V_{OL}^{(1)(3)}$	Output low level voltage for PA3/RESET standard I/O pin (see Figure 51)	$I_{IO} = +2 \text{ mA}, T_A \leq 125 \text{ }^\circ\text{C}$		500	
		Output low level voltage for a high sink I/O pin when 4 pins are sunk at same time (see Figure 54)	$I_{IO} = +2 \text{ mA}, T_A \leq 125 \text{ }^\circ\text{C}$		
	$I_{IO} = +8 \text{ mA}, T_A \leq 125 \text{ }^\circ\text{C}$			600	
$V_{OH}^{(2)(3)}$	Output high level voltage for an I/O pin when 4 pins are sourced at same time (see Figure 57)	$I_{IO} = -2 \text{ mA}, T_A \leq 125 \text{ }^\circ\text{C}$	$V_{DD}-800$		
$V_{OL}^{(1)(3)}$	Output low level voltage for PA3/RESET standard I/O pin (see Figure 53)	$I_{IO} = +2 \text{ mA}, T_A \leq 125 \text{ }^\circ\text{C}$		700	
		Output low level voltage for a high sink I/O pin when 4 pins are sunk at same time (see Figure 53)	$I_{IO} = +2 \text{ mA}, T_A \leq 125 \text{ }^\circ\text{C}$		200
	$I_{IO} = +8 \text{ mA}, T_A \leq 125 \text{ }^\circ\text{C}$			800	
$V_{OH}^{(2)(3)}$	Output high level voltage for an I/O pin when 4 pins are sourced at same time (see Figure 56)	$I_{IO} = -2 \text{ mA}, T_A \leq 125 \text{ }^\circ\text{C}$	$V_{DD}-900$		

- The I_{IO} current sunk must always respect the absolute maximum rating specified in [Table 52](#) and the sum of I_{IO} (I/O ports and control pins) must not exceed I_{VSS} .
- The I_{IO} current sourced must always respect the absolute maximum rating specified in [Table 52](#) and the sum of I_{IO} (I/O ports and control pins) must not exceed I_{VDD} . True open drain I/O pins do not have V_{OH} .
- Not tested in production, based on characterization results.

Figure 50. Typical V_{OL} at $V_{DD} = 2.4\text{ V}$ (standard pins)

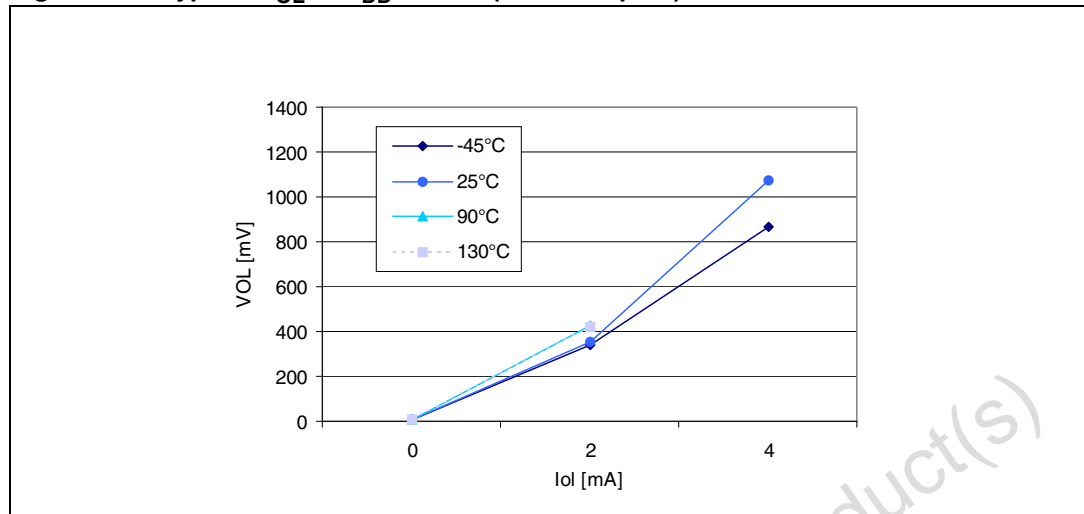

Figure 51. Typical V_{OL} at $V_{DD} = 3\text{ V}$ (standard pins)

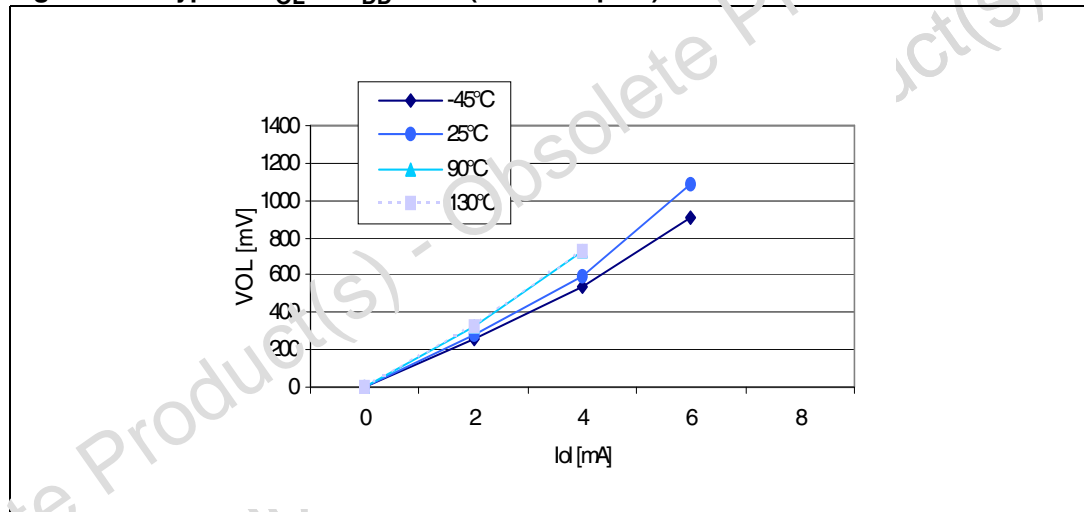

Figure 52. Typical V_{OL} at $V_{DD} = 5\text{ V}$ (standard pins)

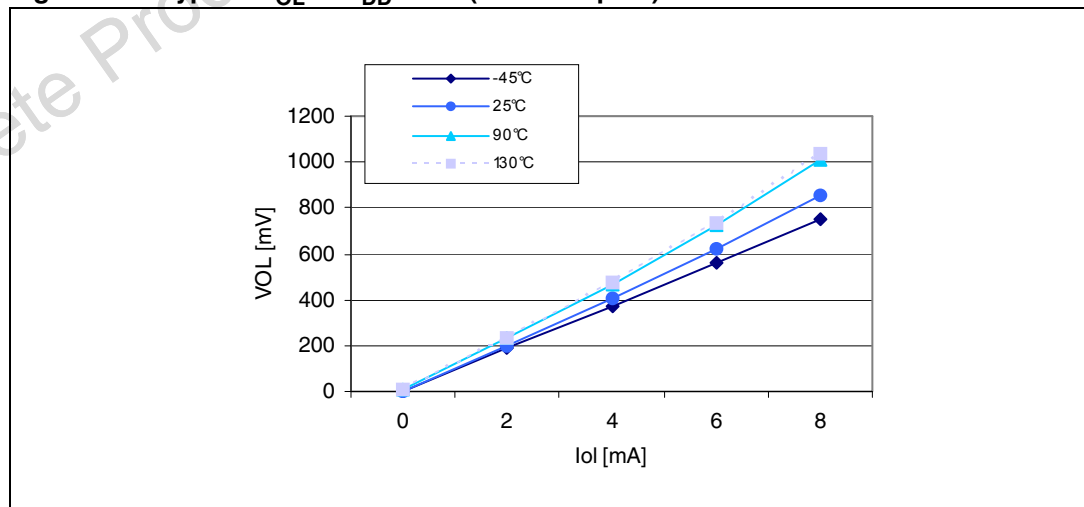

Figure 53. Typical V_{OL} at $V_{DD} = 2.4\text{ V}$ (HS pins)

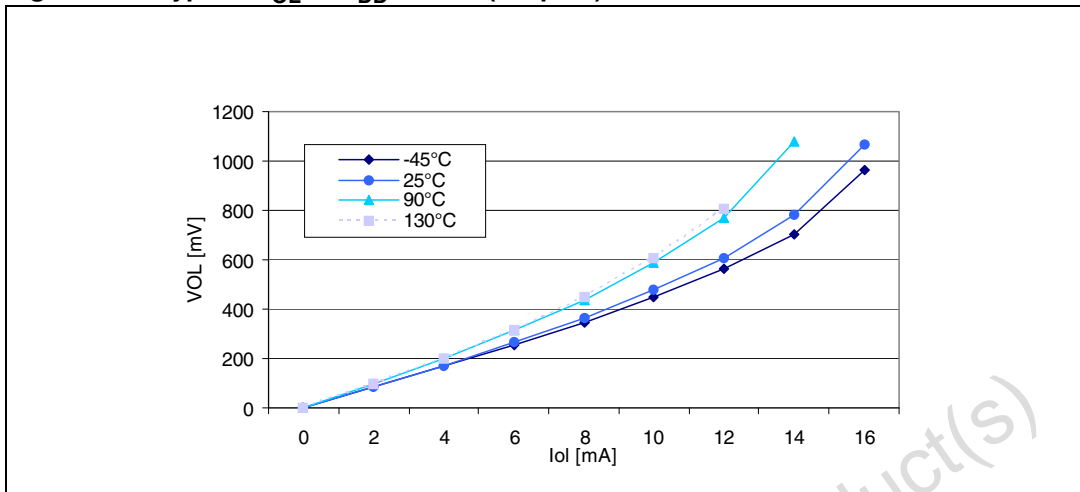

Figure 54. Typical V_{OL} at $V_{DD} = 3\text{ V}$ (HS pins)

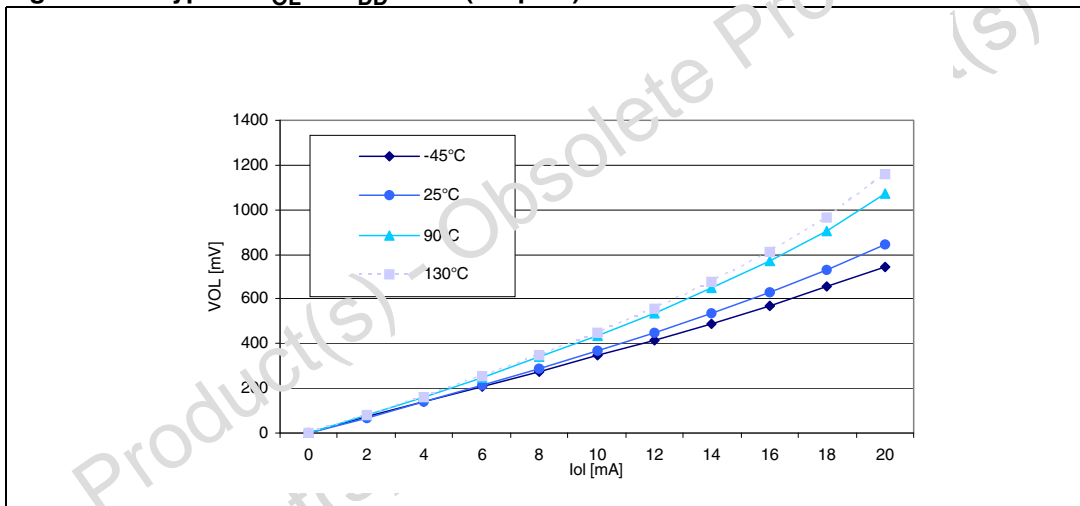

Figure 55. Typical V_{OL} at $V_{DD} = 5\text{ V}$ (HS pins)

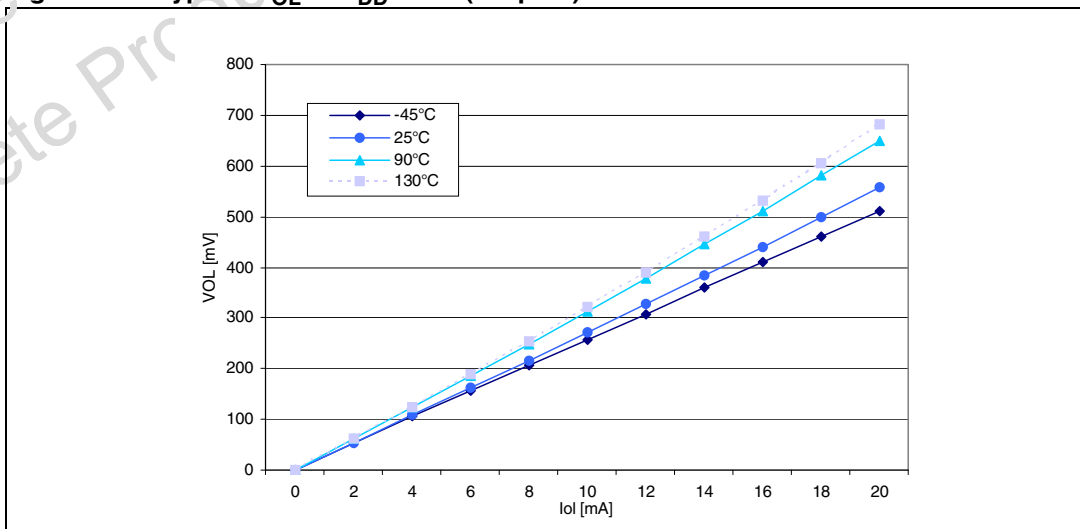

Figure 56. Typical $V_{DD}-V_{OH}$ at $V_{DD} = 2.4\text{ V}$ (HS pins)

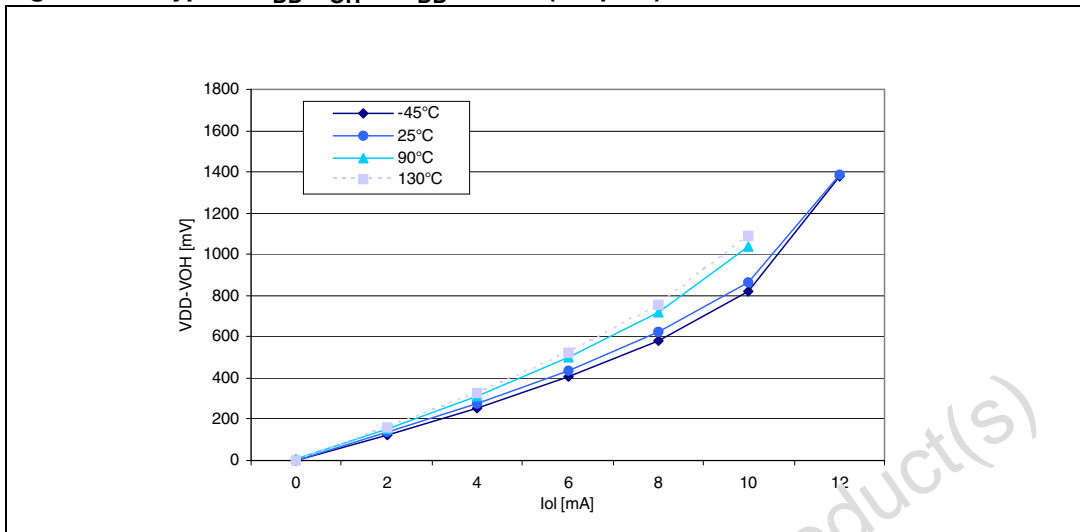

Figure 57. Typical $V_{DD}-V_{OH}$ at $V_{DD} = 3\text{ V}$ (HS pins)

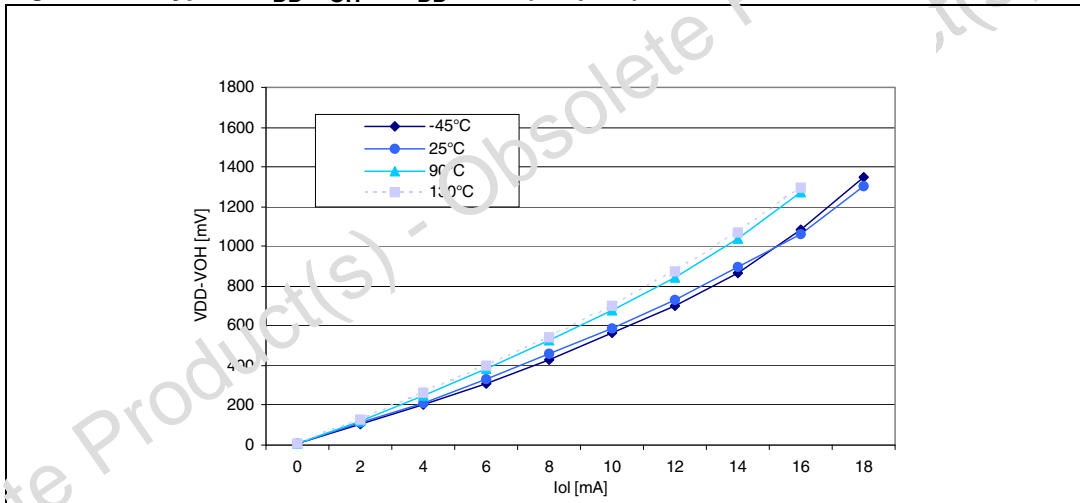

Figure 58. Typical $V_{DD}-V_{OH}$ at $V_{DD} = 5\text{ V}$ (HS pins)

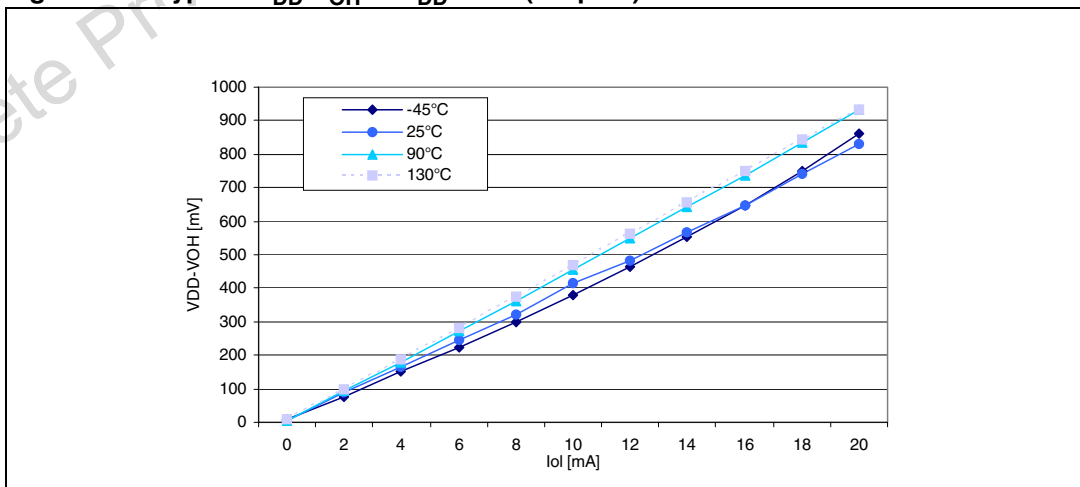

Figure 59. Typical V_{OL} vs. V_{DD} (HS pins)

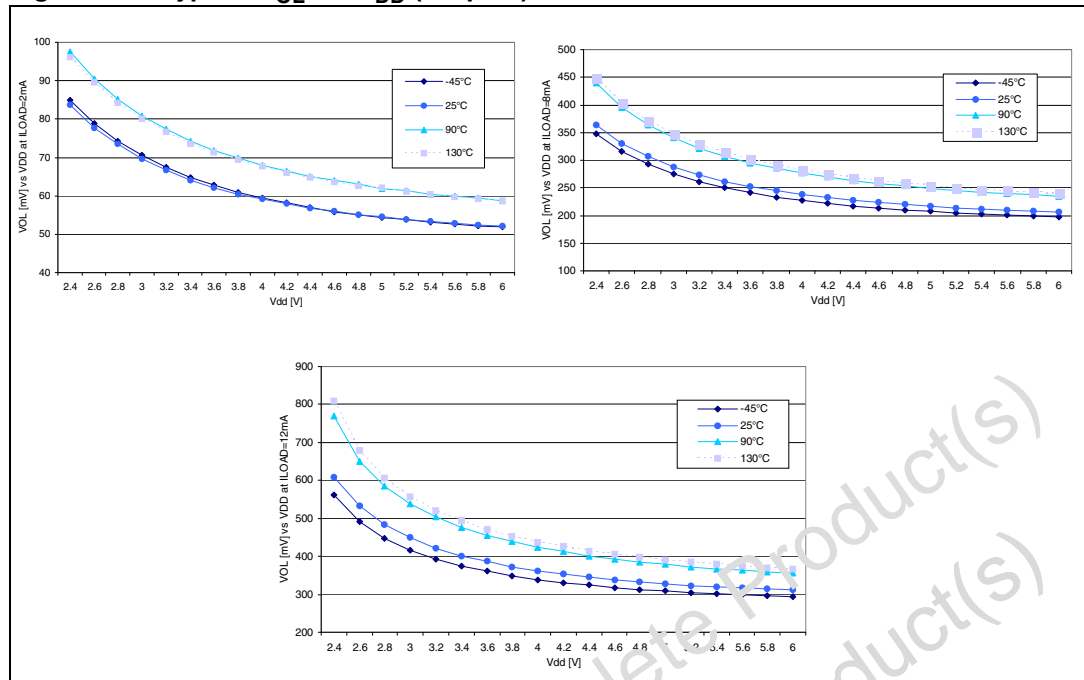
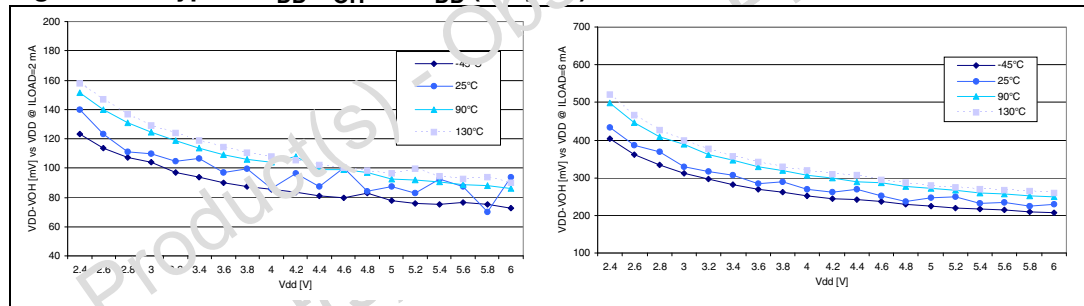

Figure 60. Typical $V_{DD}-V_{OH}$ vs. V_{DD} (HS pins)



12.9 Control pin characteristics

The reset network protects the device against parasitic resets.

The output of the external reset circuit must have an open-drain output to drive the ST7 reset pad. Otherwise the device can be damaged when the ST7 generates an internal reset (LVD or watchdog).

Whatever the reset source is (internal or external), the user must ensure that the level on the \overline{RESET} pin can go below the V_{IL} max. level specified in Table 65. Otherwise the reset will not be taken into account internally.

Because the reset circuit is designed to allow the internal reset to be output in the \overline{RESET} pin, the user must ensure that the current sunk on the \overline{RESET} pin is less than the absolute maximum value specified for $I_{INJ}(\overline{RESET})$ in Table 44.

Refer to Figure 61 and Figure 62 for a description of the \overline{RESET} pin protection circuit with LVD enabled and disabled.

Refer also to [Section 11.2.1: Illegal opcode reset](#) for more details on illegal opcode reset conditions.

Table 65. Asynchronous $\overline{\text{RESET}}$ pin characteristics ⁽¹⁾

Symbol	Parameter	Conditions	Min	Typ	Max	Unit
V_{IL}	Input low level voltage		$V_{SS} - 0.3$		$0.3V_{DD}$	V
V_{IH}	Input high level voltage		$0.7V_{DD}$		$V_{DD} + 0.3$	V
V_{hys}	Schmitt trigger voltage hysteresis ⁽²⁾			2		V
V_{OL}	Output low level voltage ⁽³⁾	$V_{DD}=5\text{ V}$ $I_{IO}=+2\text{ mA}$			400	mV
R_{ON}	Pull-up equivalent resistor ⁽⁴⁾	$V_{IN}=V_{SS}$ $V_{DD}=5\text{ V}$ $V_{DD}=3\text{ V}$	30	50 30 ^(?)	70	k Ω
$t_{w(RSTL)out}$	Generated reset pulse duration	Internal reset sources		90 ⁽²⁾		μs
$t_{h(RSTL)in}$	External reset pulse hold time ⁽⁵⁾		20			μs
$t_{g(RSTL)in}$	Filtered glitch duration			200		ns

- $T_A = -40^\circ\text{C}$ to 125°C , unless otherwise specified.
- Data based on characterization results, not tested in production.
- The I_{IO} current sunk must always respect the absolute maximum rating specified in [Table 44](#) and the sum of I_{IO} (I/O ports and control pins) must not exceed I_{VSS} .
- The R_{ON} pull-up equivalent resistor is based on a resistive transistor. Specified for voltages on $\overline{\text{RESET}}$ pin between V_{ILmax} and V_{DD} .
- To guarantee the reset of the device, a minimum pulse has to be applied to the $\overline{\text{RESET}}$ pin. All short pulses applied on $\overline{\text{RESET}}$ pin with a duration below $t_{h(RSTL)in}$ can be ignored.

Figure 61. $\overline{\text{RESET}}$ pin protection when LVD is enabled

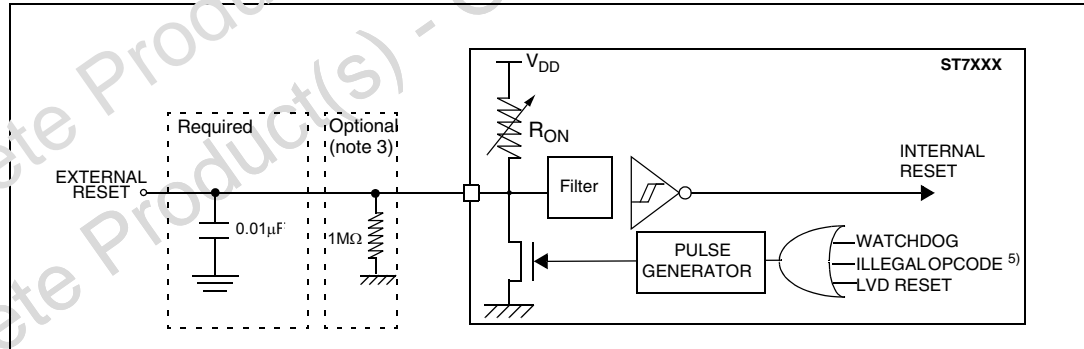

- When the LVD is enabled, it is recommended not to connect a pull-up resistor or capacitor. A 10nF pull-down capacitor is required to filter noise on the reset line.
- When using the LVD:
 - Check that all recommendations related to ICCCLK and reset circuit have been applied (see caution in [Table 2](#) and text above)
 - Check that the power supply is properly decoupled (100nF + 10µF close to the MCU). Refer to [AN1709](#) and [AN2017](#). If this cannot be done, it is recommended to put a 100nF + 1M Ω pull-down on the $\overline{\text{RESET}}$ pin.
 - The capacitors connected on the $\overline{\text{RESET}}$ pin and also the power supply are key to avoid any startup marginality. In most cases, steps 1 and 2 above are sufficient for a robust solution. Otherwise: replace 10nF pull-down on the $\overline{\text{RESET}}$ pin with a 5µF to 20µF capacitor."
- In case a capacitive power supply is used, it is recommended to connect a 1M Ω pull-down resistor to the $\overline{\text{RESET}}$ pin to discharge any residual voltage induced by the capacitive effect of the power supply (this will add 5µA to the power consumption of the MCU).

Figure 62. RESET pin protection when LVD is disabled

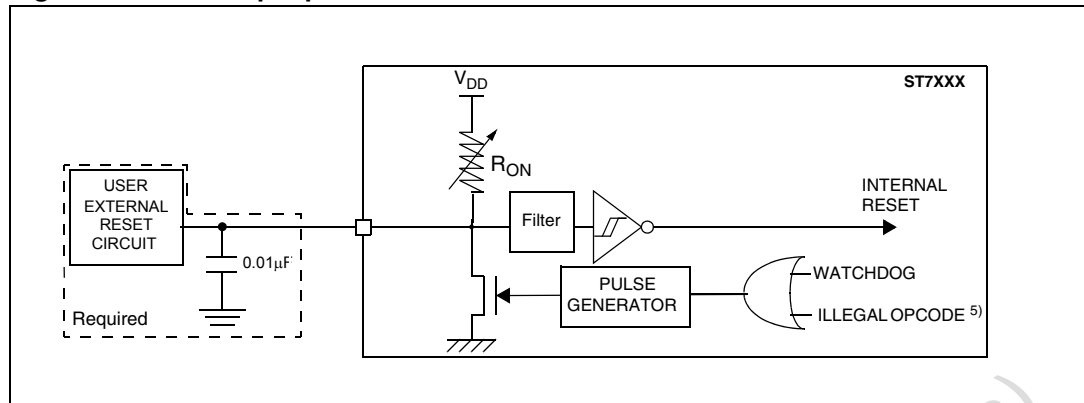

12.10 ADC characteristics

Subject to general operating condition for V_{DD} , f_{OSC} , and T_A unless otherwise specified.

Table 66. 10-bit ADC characteristics

Symbol	Parameter	Conditions	Min	Typ ⁽¹⁾	Max	Unit
f_{ADC}	ADC clock frequency ⁽²⁾				4	MHz
V_{AIN}	Conversion voltage range ⁽³⁾		V_{SSA}		V_{DDA}	V
R_{AIN}	External input resistor	$V_{DD} = 5\text{ V}$, $f_{ADC}=4\text{ MHz}$			8 ⁽⁴⁾	k Ω
		$V_{DD} = 3.3\text{ V}$, $f_{ADC}=4\text{ MHz}$			7 ⁽⁴⁾	
		$2.7\text{ V} \leq V_{DD} \leq 5.5\text{ V}$, $f_{ADC}=2\text{ MHz}$			10 ⁽⁴⁾	
		$2.4\text{ V} \leq V_{DD} \leq 2.7\text{ V}$, $f_{ADC}=1\text{ MHz}$			TBD ⁽⁴⁾	
C_{ADC}	Internal sample and hold capacitor			3		pF
t_{STAB}	Stabilization time after ADC enable			0 ⁽⁵⁾		μs
t_{ADC}	Conversion time (Sample+Hold)	$f_{CPU}=8\text{ MHz}$, $f_{ADC}=4\text{ MHz}$		3.5		
	- Sample capacitor loading time - Hold conversion time			4 10		$1/f_{ADC}$

1. Unless otherwise specified, typical data are based on $T_A=25^\circ\text{C}$ and $V_{DD}-V_{SS}=5\text{ V}$. They are given only as design guidelines and are not tested.
2. The maximum ADC clock frequency allowed within $V_{DD} = 2.4$ to 2.7 V operating range is 1 MHz .
3. When V_{DDA} and V_{SSA} pins are not available on the pinout, the ADC refers to V_{DD} and V_{SS} .
4. Any added external serial resistor will downgrade the ADC accuracy (especially for resistance greater than $10\text{ k}\Omega$). Data based on characterization results, not tested in production.
5. The stabilization time of the A/D converter is masked by the first t_{LOAD} . The first conversion after the enable is then always valid.

Figure 63. Typical application with ADC

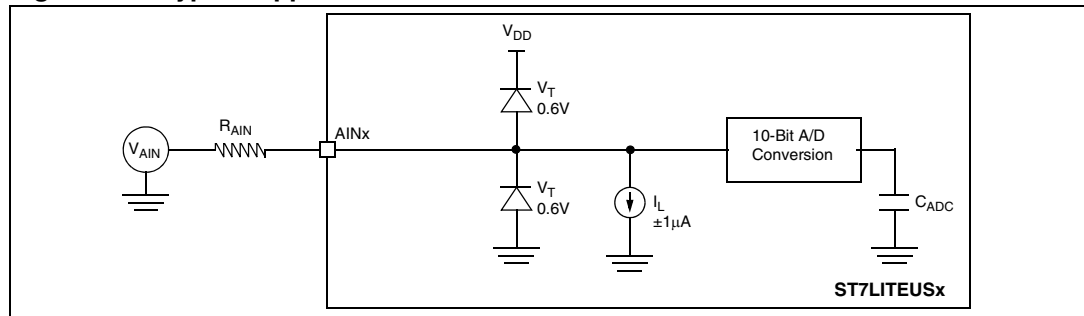

Table 67. ADC accuracy with $V_{DD} = 3.3$ to 5.5 V

Symbol (1)	Parameter	Conditions	Typ	Max	Unit
$ E_T $	Total unadjusted error	$f_{CPU}=8$ MHz, $f_{ADC}=4$ MHz ⁽¹⁾	2.1	5.0	LSB
$ E_O $	Offset error		0.2	2.5	
$ E_G $	Gain Error		0.3	1.5	
$ E_D $	Differential linearity error		1.9	3.5	
$ E_L $	Integral linearity error		1.9	4.5	

1. Data based on characterization results over the whole temperature range.

Table 68. ADC accuracy with $V_{DD} = 2.7$ to 3.3 V

Symbol (1)	Parameter	Conditions	Typ	Max	Unit
$ E_T $	Total unadjusted error	$f_{CPU}=4$ MHz, $f_{ADC}=2$ MHz ⁽¹⁾	2.0	3.0	LSB
$ E_O $	Offset error		0.1	1.5	
$ E_G $	Gain Error		0.4	1.4	
$ E_D $	Differential linearity error		1.8	2.5	
$ E_L $	Integral linearity error		1.7	2.5	

1. Data based on characterization results over the whole temperature range.

Table 69. ADC accuracy with $V_{DD} = 2.4$ V to 2.7 V

Symbol (1)	Parameter	Conditions	Typ	Max	Unit
$ E_T $	Total unadjusted error	$f_{CPU}=2$ MHz, $f_{ADC}=1$ MHz ⁽¹⁾	2.2	3.5	LSB
$ E_O $	Offset error		0.5	1.5	
$ E_G $	Gain Error		0.5	1.5	
$ E_D $	Differential linearity error		1.8	2.5	
$ E_L $	Integral linearity error		1.8	2.5	

1. Data based on characterization results at a temperature $\geq 25^\circ\text{C}$.

Figure 64. ADC accuracy characteristics

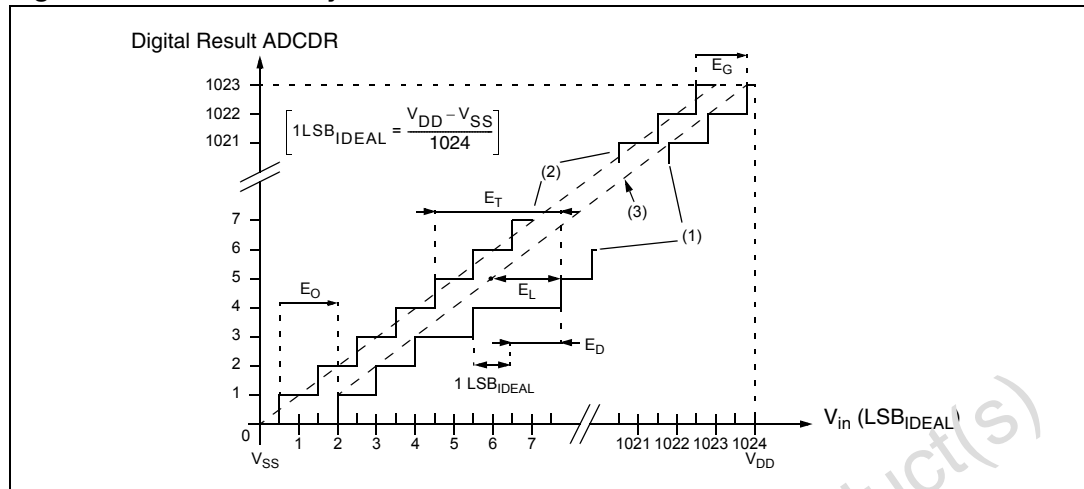

1. Example of an actual transfer curve
2. The ideal transfer curve
3. End point correlation line
4. E_T =Total Unadjusted Error: maximum deviation between the actual and the ideal transfer curves.
5. E_O =Offset Error: deviation between the first actual transition and the first ideal one.
6. E_G =Gain Error: deviation between the last ideal transition and the last actual one.
7. E_D =Differential Linearity Error: maximum deviation between actual steps and the ideal one.
8. E_L =Integral Linearity Error: maximum deviation between any actual transition and the end point correlation line.

13 Package characteristics

In order to meet environmental requirements, ST offers these devices in different grades of ECOPACK® packages, depending on their level of environmental compliance. ECOPACK® specifications, grade definitions and product status are available at: www.st.com. ECOPACK® is an ST trademark.

13.1 Package mechanical data

Figure 65. 8-lead very thin fine pitch dual flat no-lead package outline

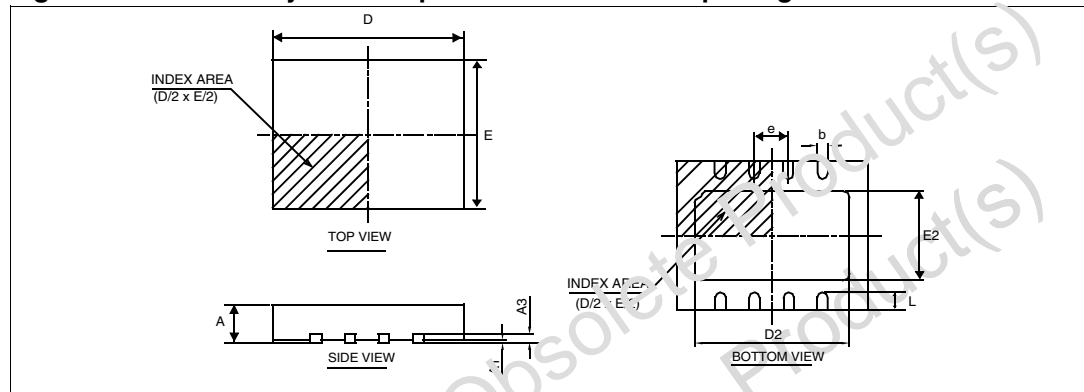

Table 70. 8-lead very thin fine pitch dual flat no-lead package mechanical data

Dim.	mm			inches ⁽¹⁾		
	Min	Typ	Max	Min	Typ	Max
A	0.90	0.90	1.00	0.0310	0.0350	0.0390
A1	0.00	0.02	0.05	0.0000	0.0010	0.0020
A3		0.20			0.0080	
b	0.25	0.30	0.35	0.0100	0.0120	0.0140
D		4.50			0.1770	
D2	3.50	3.65	3.75	0.1380	0.1440	0.1480
E		3.50			0.1380	
E2	1.96	2.11	2.21	0.0770	0.0830	0.0870
e		0.80			0.0310	
L	0.30	0.40	0.50	0.0120	0.0160	0.0200
	Number of pins					
N	8					

1. Values in inches are converted from mm and rounded to 4 decimal digits.

Figure 66. 8-pin plastic small outline package, 150-mil width package outline

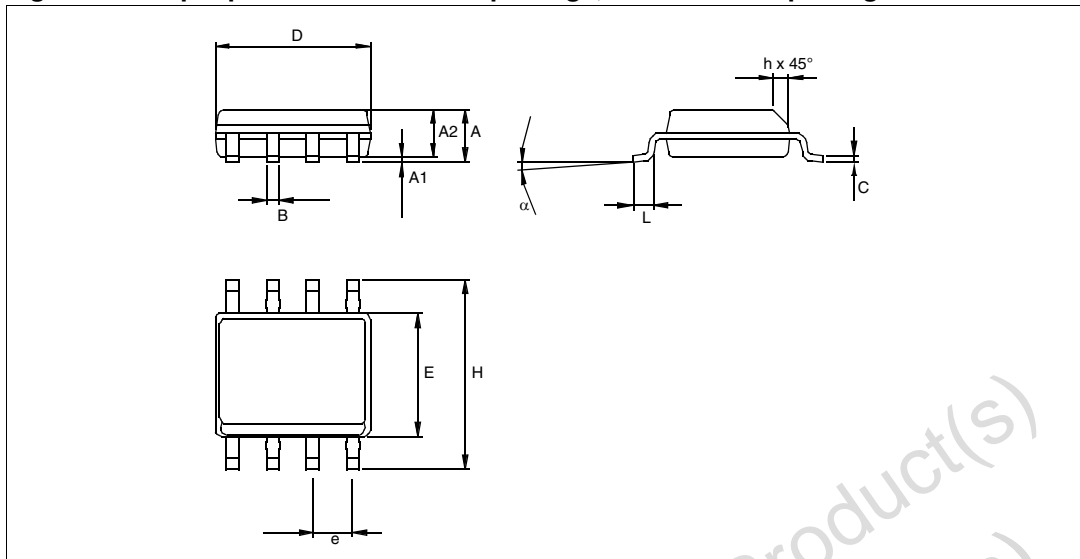

Table 71. 8-pin plastic small outline package, 150-mil width, package mechanical data

Dim.	mm			inches ⁽¹⁾		
	Min	Typ	Max	Min	Typ	Max
A	1.35		1.75	0.0530		0.0690
A1	0.10		0.25	0.0040		0.0100
A2	1.10		1.65	0.0430		0.0650
B	0.53		0.51	0.0130		0.0200
C	0.19		0.25	0.0070		0.0100
D	4.80		5.00	0.1890		0.1970
E	3.80		4.00	0.1500		0.1580
e		1.27			0.0500	
H	5.80		6.20	0.2280		0.2440
h	0.25		0.50	0.0100		0.0200
α	0d		8d			
L	0.40		1.27	0.0160		0.0500
	Number of pins					
N	8					

1. Values in inches are converted from mm and rounded to 4 decimal digits.

Figure 67. 8-pin plastic dual in-line package, 300-mil width package outline

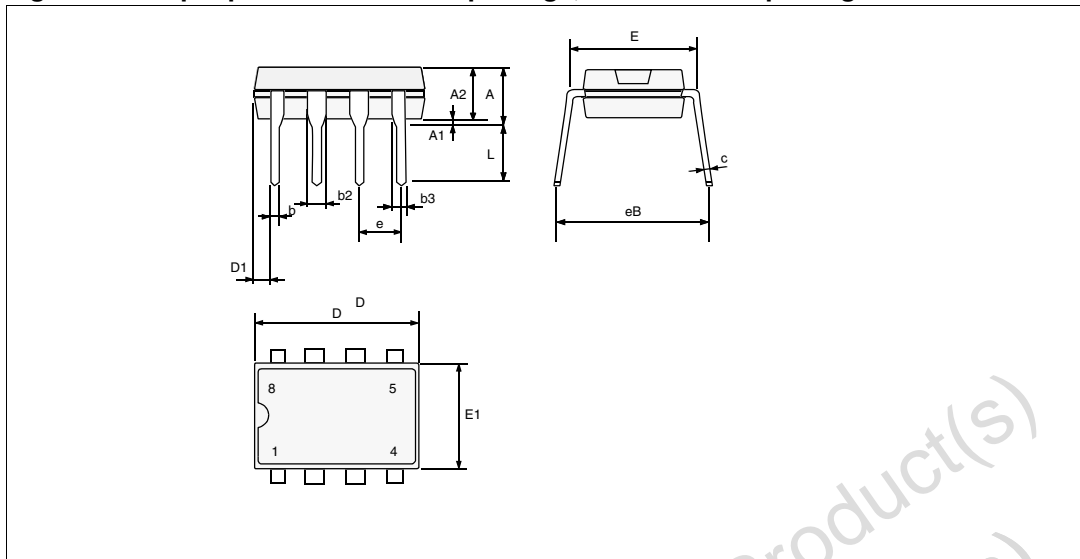

Table 72. 8-pin plastic dual in-line package, 300-mil width package mechanical data

Dim.	mm			inches ⁽¹⁾		
	Min	Typ	Max	Min	Typ	Max
A			5.33			0.2100
A1	0.38			0.0150		
A2	2.92	3.30	4.95	0.1150	0.1300	0.1950
b	0.36	0.46	0.56	0.0140	0.0180	0.0220
b2	1.14	1.52	1.78	0.0450	0.0600	0.0700
b3	0.76	0.99	1.14	0.0300	0.0390	0.0450
c	0.20	0.25	0.36	0.0080	0.0100	0.0140
D	9.02	9.27	10.16	0.3550	0.3650	0.4000
D1	0.13			0.0050		
e		2.54			0.1000	
eB			10.92			0.4300
E	7.62	7.87	8.26	0.3000	0.3100	0.3250
E1	6.10	6.35	7.11	0.2400	0.2500	0.2800
L	2.92	3.30	3.81	0.1150	0.1300	0.1500
	Number of pins					
N	8					

1. Values in inches are converted from mm and rounded to 4 decimal digits.

Figure 68. 16-pin plastic dual in-line package, 300-mil width, package outline

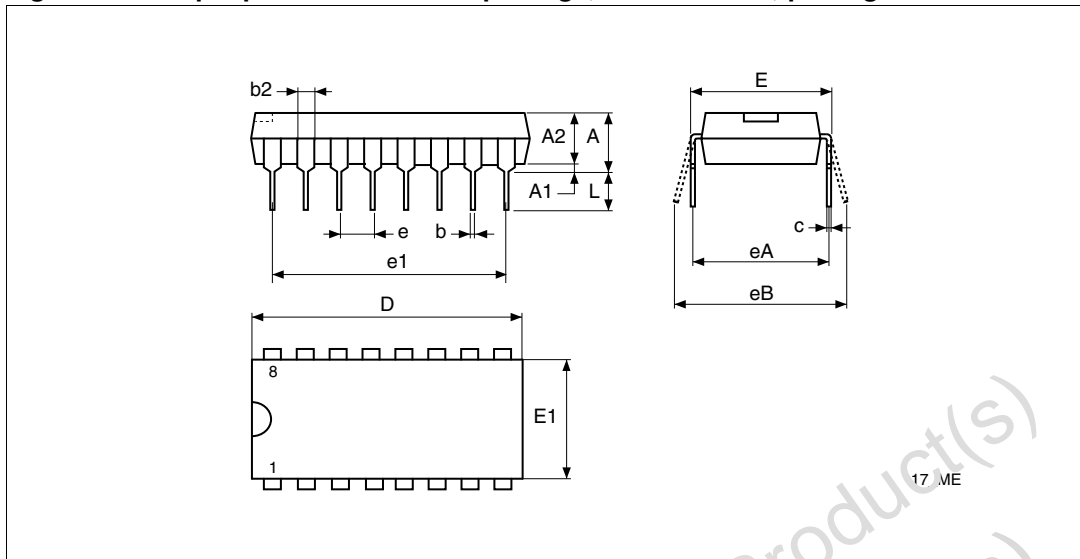

Table 73. 16-pin plastic dual in-line package, 300-mil width, package mechanical data

Dim.	mm			inches ⁽¹⁾		
	Min	Typ	Max	Min	Typ	Max
A			5.33			0.2100
A1	0.38			0.0150		
A2	2.92	3.30	4.95	0.1150	0.1300	0.1950
b	0.33	0.46	0.56	0.0140	0.0180	0.0220
b2	1.14	1.52	1.78	0.0450	0.0600	0.0700
e	0.20	0.25	0.36	0.0080	0.0100	0.0140
D	18.67	19.18	19.69	0.7350	0.7550	0.7750
E	7.62	7.87	8.26	0.3000	0.3100	0.3250
E1	6.10	6.35	7.11	0.2400	0.2500	0.2800
eA		2.54			0.1000	
e1		17.78			0.7	
eA		7.62				0.3000
eB			10.92			0.4300
L	2.92	3.30	3.81	0.1150	0.1300	0.1500
N	Number of pins					
	16					

1. Values in inches are converted from mm and rounded to 4 decimal digits.

13.2 Thermal characteristics

Table 74. Thermal characteristics

Symbol	Ratings		Value	Unit
R _{thJA}	Package thermal resistance (junction to ambient)	Plastic DIP8	82	°C/W
		SO8	130	
		DFN8 (on 4-layer PCB)	50	
		DFN8 (on 2-layer PCB)	106	
T _{Jmax}	Maximum junction temperature ⁽¹⁾		150	°C
P _{Dmax}	Power dissipation ⁽²⁾	Plastic DIP8	300	mW
		SO8	180	
		DFN8 (on 4-layer PCB)	500	
		DFN8 (on 2-layer PCB)	250	

1. The maximum chip-junction temperature is based on technology characteristics.
2. The maximum power dissipation is obtained from the formula $P_D = (T_J - T_A) / R_{thJA}$. The power dissipation of an application can be defined by the user with the formula: $P_D = P_{INT} + P_{PORT}$ where P_{INT} is the chip internal power ($I_{DD} \times V_{DD}$) and P_{PORT} is the port power dissipation depending on the ports used in the application.

14 Device configuration and ordering information

Each device is available for production in user programmable versions (FLASH) as well as in factory coded versions (FASTROM). Refer to [Table 79](#) for the full list of supported part numbers:

- ST7FLITEUSA2xx and ST7FLITEUSA5xx XFlash devices are shipped to customers with a default program memory content (FFh).
- Factory Advanced Service Technique ROM (FASTROM) versions are also available: they are factory-programmed XFlash devices.

The FASTROM factory coded parts contain the code supplied by the customer. This implies that FLASH devices have to be configured by the customer using the Option Bytes while the FASTROM devices are factory-configured.

14.1 Option bytes

The two option bytes allow the hardware configuration of the microcontroller to be selected.

The option bytes can be accessed only in programming mode (for example using a standard ST7 programming tool).

14.1.1 OPTION BYTE 1

Bit 7:6 **CKSEL[1:0]** *Startup clock selection.*

This bit is used to select the startup frequency. By default, the internal RC is selected (see [Table 75: Startup clock selection](#)).

Bit 5 **Reserve**, must always be 1.

Bit 4 **Reserved**, must always be 0.

Bits 3:2 **LVD[1:0]** *Low Voltage Detection selection*

These option bits enable the LVD block with a selected threshold as shown in [Table 76: LVD threshold configuration](#).

Bit 1 **WDG SW** *Hardware or software watchdog*

This option bit selects the watchdog type.

0: Hardware (watchdog always enabled)

1: Software (watchdog to be enabled by software)

Bit 0 **WDG HALT** *Watchdog Reset on Halt*

This option bit determines if a reset is generated when entering Halt mode while the watchdog is active.

0: No Reset generation when entering Halt mode

1: Reset generation when entering Halt mode

Table 75. Startup clock selection

Configuration	CKSEL1	CKSEL0
Internal RC as Startup Clock	0	0
Reserved	0	0
AWU RC as a Startup Clock	0	1
Reserved	1	0
External Clock on pin PA5	1	1

Table 76. LVD threshold configuration

Configuration	LVD1	LVD0
LVD Off	1	1
Highest voltage threshold	1	0
Medium voltage threshold	0	1
Lowest voltage threshold	0	0

14.1.2 OPTION BYTE 0

Bits 7:4 Reserved, must always be 1.

Bit 3 Reserved, must always be 0.

Bit 2 **SEC0** *Sector 0 size definition*

This option bit indicates the size of sector 0 according to the following table (see [Table 77: Definition of sector 0 size](#)).

Bit 1 **FMP_R** *Readout protection*

Readout protection, when selected provides a protection against program memory content extraction and against write access to Flash memory. Erasing the option bytes when the FMP_R option is selected will cause the whole memory to be erased first, and the device can be reprogrammed. Refer to [Section 4.5](#) and the ST7 Flash Programming Reference Manual for more details.

0: Readout protection off

1: Readout protection on

Bit 0 **FMP_W** *FLASH write protection*

This option indicates if the FLASH program memory is write protected.

Warning: When this option is selected, the program memory (and the option bit itself) can never be erased or programmed again.

0: Write protection off

1: Write protection on

Table 77. Definition of sector 0 size

Sector 0 Size	SEC0
0.5k	0
1k	1

Table 78:

	OPTION BYTE 0					OPTION BYTE 1										
	7	6	5	4	3	2	1	0	7	6	5	4	3	2	1	0
	Reserved					SEC0	FMPR	FMPW	CKSEL 1	CKSEL 0	Res	Res	LVD1	LVD0	WDG SW	WDG HALT
Default value	1	1	1	1	0	0	0	0	0	0	1	0	1	1	1	1

14.2 Ordering information

Customer code is made up of the FASTROM contents and the list of the selected options (if any). The FASTROM contents are to be sent on diskette, or by electronic means, with the S19 hexadecimal file generated by the development tool. All unused bytes must be set to FFh. The selected options are communicated to STMicroelectronics using the correctly completed option list appended.

Refer to application note AN1635 for information on the counter list returned by ST after code has been transferred.

The STMicroelectronics Sales Organization will be pleased to provide detailed information on contractual points.

Table 79. Supported order codes ⁽¹⁾

Order code	Program memory (bytes)	RAM (bytes)	A/D C	Temperature range	Package	Conditioning
ST7FLITEUSA2B6	1 Kbyte FLASH	128	-	-40°C +85°C	DIP8	Tube
ST7FLITEUSA2M6			-		SO8	Tube
ST7FLITEUSA2M6TR			-		SO8	Tape & Reel
ST7FLITEUSA2U6TR			-		DFN8	Tape & Reel
ST7FLITEUSA5B6	1 Kbyte FLASH	128	10-bit	-40°C +85°C	DIP8	Tube
ST7FLITEUSA5M6			10-bit		SO8	Tube
ST7FLITEUSA5M6TR			10-bit		SO8	Tape & Reel
ST7FLITEUSA5U6			10-bit		DFN8	Tray
ST7FLITEUSA5U6TR			10-bit		DFN8	Tape & Reel
ST7FLITEUSICD	1 Kbyte FLASH	128	-	-40°C +125°C	DIP16 ⁽²⁾	Tube
ST7PLUSA2B6	1 Kbyte FASTROM	128	-	-40°C +85°C	DIP8	Tube
ST7PLUSA2M6			-		SO8	Tube
ST7PLUSA2M6TR			-		SO8	Tape & Reel
ST7PLUSA2U6TR			-		DFN8	Tape & Reel

Table 79. Supported order codes ⁽¹⁾ (continued)

Order code	Program memory (bytes)	RAM (bytes)	ADC	Temperature range	Package	Conditioning
ST7PLUSA5B6	1 Kbyte FASTROM	128	10-bit	-40°C +85°C	DIP8	Tube
ST7PLUSA5M6			10-bit		SO8	Tube
ST7PLUSA5M6TR			10-bit		SO8	Tape & Reel
ST7PLUSA5U6			10-bit		DFN8	Tray
ST7PLUSA5U6TR			10-bit		DFN8	Tape & Reel
ST7PLUSA2B3	1 Kbyte FLASH	128	-	-40°C +125°C	DIP8	Tube
ST7PLUSA2M3			-		SO8	Tube
ST7PLUSA2M3TR			-		SO8	Tape & Reel
ST7PLUSA2U3TR			-		DFN8	Tape & Reel
ST7PLUSA5B3	1 Kbyte FLASH	128	10-bit	-40°C +125°C	DIP8	Tube
ST7PLUSA5M3			10-bit		SO8	Tube
ST7PLUSA5M3TR			10-bit		SO8	Tape & Reel
ST7PLUSA5U3			10-bit		DFN8	Tray
ST7PLUSA5U3TR			10-bit		DFN8	Tape & Reel
ST7PLUSA2B3	1 Kbyte FASTROM	128	-	-40°C +125°C	DIP8	Tube
ST7PLUSA2M3			-		SO8	Tube
ST7PLUSA2M3TR			-		SO8	Tape & Reel
ST7PLUSA2U3TR			-		DFN8	Tape & Reel
ST7PLUSA5B3	1 Kbyte FASTROM	128	10-bit	-40°C +125°C	DIP8	Tube
ST7PLUSA5M3			10-bit		SO8	Tube
ST7PLUSA5M3TR			10-bit		SO8	Tape & Reel
ST7PLUSA5U3			10-bit		DFN8	Tray
ST7PLUSA5U3TR			10-bit		DFN8	Tape & Reel

1. Contact ST sales office for product availability.

2. For development or tool prototyping purposes only, not orderable in production quantities.

Figure 69. Option list

```

ST7LITEUS FASTROM MICROCONTROLLER OPTION LIST
(Last update: February 2009)

Customer: . . . . .
Address: . . . . .
Contact: . . . . .
Phone No: . . . . .
Reference/FASTROM Code*: . . . . .
*FASTROM code name is assigned by STMicroelectronics.
FASTROM code must be sent in .S19 format. .Hex extension cannot be processed.

Device Type/Memory Size/Package (check only one option):
-----|-----|
FASTROM DEVICE: | 1K FASTROM |
-----|-----|
PDIP8           | [ ]          |
SO8             | [ ]          |
DFN8           | [ ]          |

Conditioning (check only one option):
-----
DIP package: [ ] Tube
SO package:  [ ] Tape & Reel [ ] Tube
DFN package: [ ] Tape & Reel [ ] Tray (for ST7PLUSA5U6xxx and ST7PLUSA5U3xxx
only)

Special Marking: [ ] No [ ] Yes "-----"
Authorized characters are letters, digits, '.', '-', '/', and spaces only.
Maximum character count:
PDIP8/SO8/DFN8 (8 char. max) : -----

Temperature range [ ] -40°C to +85°C [ ] -40°C to +125°C

Clock Source Selection: [ ] External Clock
                       [ ] AWU RC oscillator
                       [ ] Internal RC oscillator

Sector size:          [ ] 0.5K [ ] 1K
Readout protection:  [ ] Disabled [ ] Enabled
FLASH Write Protection: [ ] Disabled [ ] Enabled
LVD Reset [ ] Disabled [ ] Highest threshold
[ ] Medium threshold
[ ] Lowest threshold

Watchdog Selection:  [ ] Software Activation [ ] Hardware Activation
Watchdog Reset on Halt: [ ] Disabled [ ] Enabled

Comments: . . . . .
Supply Operating Range in the application: . . . . .
Notes: . . . . .
Date: . . . . .
Signature: . . . . .

Important note: Not all configurations are available. Refer to datasheet for
authorized option byte combinations.

Please download the latest version of this option list from:
http://www.st.com/mcu > downloads > ST7 microcontrollers > Option list
    
```

14.3 Development tools

Development tools for the ST7 microcontrollers include a complete range of hardware systems and software tools from STMicroelectronics and third-party tool suppliers. The range of tools includes solutions to help you evaluate microcontroller peripherals, develop and debug your application, and program your microcontrollers.

14.3.1 Starter kits

ST offers complete, affordable **starter kits**. Starter kits are complete, affordable hardware/software tool packages that include features and samples to help you quickly start developing your application.

14.3.2 Development and debugging tools

Application development for ST7 is supported by fully optimizing **C Compilers** and the **ST7 Assembler-Linker** toolchain, which are all seamlessly integrated in the ST7 integrated development environments in order to facilitate the debugging and fine-tuning of your application. The Cosmic C Compiler is available in a free version that outputs up to 16 Kbytes of code.

The range of hardware tools includes full-featured **ST7-EMU3 series emulators**, cost effective **ST7-DVP3 series emulators** and the low-cost **RLink** in-circuit debugger/programmer. These tools are supported by the **ST7 Toolset** from STMicroelectronics, which includes the STVD7 integrated development environment (IDE) with high-level language debugger, editor, project manager and integrated programming interface.

14.3.3 Programming tools

During the development cycle, the **ST7-DVP3** and **ST7-EMU3 series emulators** and the **RLink** provide in-circuit programming capability for programming the Flash microcontroller on your application board.

ST also provides a low-cost dedicated in-circuit programmer, the **ST7-STICK**, as well as **ST7 Socket Boards** which provide all the sockets required for programming any of the devices in a specific ST7 sub-family on a platform that can be used with any tool with in-circuit programming capability for ST7.

For production programming of ST7 devices, ST's third-party tool partners also provide a complete range of gang and automated programming solutions, which are ready to integrate into your production environment.

14.3.4 Order codes for development and programming tools

[Table 80](#) below lists the ordering codes for the ST7LITEUSx development and programming tools. For additional ordering codes for spare parts and accessories, refer to the online product selector at www.st.com/mcu.

Table 80. Development tool order codes for the ST7LITEUSx family

Supported products	In-circuit Debugger, RLink series ⁽¹⁾		Emulator		Programming tool	
	Starter kit without demo board	Starter kit with Demo Board	DVP series	EMU series	In-circuit programmer	ST socket boards and EPBs
ST7FLITEUS2 ST7FLITEUS5	STX-RLINK ⁽²⁾	STFLITE-SK/RAIS ⁽²⁾	ST7MDT10-DVP3 ⁽³⁾	ST7MDT10-EMU3	STX-RLINK ST7-STICK ⁽⁵⁾⁽⁴⁾	ST7SB10-SU0 ⁽⁵⁾

1. Available from ST or from Raisonance, www.raisonance.com.

2. USB connection to PC.

3. Includes connection kit for Plastic DIP16/SO16 only. See "How to order an EMU or DVP" in ST product and tool selector guide for connection kit ordering information.

4. Parallel port connection to PC.

5. Add suffix /EU, /UK or /US for the power supply for your region.

14.4 ST7 application notes

Table 81. ST7 application notes

Identification	Description
Application examples	
AN1658	Serial numbering implementation
AN1720	Managing the readout protection in flash microcontrollers
AN1755	A high resolution/precision thermometer using ST7 and NE555
AN1756	Choosing a DALI implementation strategy with ST7DALI
AN1812	A high precision, low cost, single supply ADC for positive and negative input voltages
Example drivers	
AN 969	SCI communication between ST7 and PC
AN 970	SPI communication between ST7 and EEPROM
AN 971	I ² C communication between ST7 and M24Cxx EEPROM
AN 972	ST7 software SPI master communication
AN 973	SCI software communication with a PC using ST72251 16-bit timer
AN 974	Real time clock with ST7 Timer Output Compare
AN 976	Driving a buzzer through ST7 timer PWM function
AN 979	Driving an analog keyboard with the ST7 ADC
AN 980	ST7 keypad decoding techniques, implementing wakeup on keystroke
AN1017	Using the ST7 universal serial bus microcontroller
AN1041	Using ST7 PWM signal to generate analog output (sinusoid)
AN1042	ST7 routine for I ² C slave mode management

Table 81. ST7 application notes (continued)

Identification	Description
AN1044	Multiple interrupt sources management for ST7 MCUs
AN1045	ST7 S/W implementation of I ² C bus master
AN1046	UART emulation software
AN1047	Managing reception errors with the ST7 SCI peripherals
AN1048	ST7 software LCD driver
AN1078	PWM duty cycle switch implementing true 0% & 100% duty cycle
AN1082	Description of the ST72141 motor control peripherals registers
AN1083	ST72141 BLDC motor control software and flowchart example
AN1105	ST7 pCAN peripheral driver
AN1129	PWM management for BLDC motor drives using the ST72141
AN1130	An introduction to sensorless brushless DC motor drive applications with the ST72141
AN1148	Using the ST7263 for designing a USB mouse
AN1149	Handling Suspend mode on a USB mouse
AN1180	Using the ST7263 Kit to implement a USB game pad
AN1276	BLDC motor start routine for the ST72141 microcontroller
AN1321	Using the ST72141 motor control MCU in sensor mode
AN1325	Using the ST7 USB low-speed firmware V4.x
AN1445	Emulated 16-bit slave SPI
AN1475	Developing an ST7265X mass storage application
AN1504	Starting a PWM signal directly at high level using the ST7 16-bit timer
AN1602	16-bit timing operations using ST7262 or ST7263B ST7 USB MCUs
AN1633	Device firmware upgrade (DFU) implementation in ST7 non-USB applications
AN1712	Generating a high resolution sine wave using ST7 PWMART
AN1713	SMBus slave driver for ST7 I2C peripherals
AN1753	Software UART using 12-bit ART
AN1947	ST7MC PMAC sine wave motor control software library
General purpose	
AN1476	Low cost power supply for home appliances
AN1526	ST7FLITE0 quick reference note
AN1709	EMC design for ST Microcontrollers
AN1752	ST72324 quick reference note
Product evaluation	
AN 910	Performance benchmarking
AN 990	ST7 benefits vs industry standard

Table 81. ST7 application notes (continued)

Identification	Description
AN1077	Overview of enhanced CAN controllers for ST7 and ST9 MCUs
AN1086	U435 can-do solutions for car multiplexing
AN1103	Improved B-EMF detection for low speed, low voltage with ST72141
AN1150	Benchmark ST72 vs PC16
AN1151	Performance comparison between ST72254 & PC16F876
AN1278	LIN (local interconnect network) solutions
Product migration	
AN1131	Migrating applications from ST72511/311/214/124 to ST72521/321/324
AN1322	Migrating an application from ST7263 Rev.B to ST7263B
AN1365	Guidelines for migrating ST72C254 applications to ST72F264
AN1604	How to use ST7MDT1-TRAIN with ST72F264
AN2200	Guidelines for migrating ST7LITE1x applications to ST7FLITE1xB
Product optimization	
AN 982	Using ST7 with ceramic resonator
AN1014	How to Minimize the ST7 power consumption
AN1015	Software techniques for improving microcontroller EMC performance
AN1040	Monitoring the Vbus signal for USB Self-powered devices
AN1070	ST7 checksum self-checking capability
AN1181	Electrostatic Discharge sensitive measurement
AN1324	Calibrating the RC oscillator of the ST7FLITE0 MCU using the mains
AN1502	Emulated Data EEPROM with ST7 HDFLASH memory
AN1529	Extending the current & voltage capability on the ST7265 VDDF supply
AN1530	Accurate timebase for low-cost ST7 applications with internal RC oscillator
AN1605	Using an active RC to wakeup the ST7LITE0 from power saving mode
AN1636	Understanding and minimizing ADC conversion errors
AN1828	PIR (passive Infrared) detector using the ST7FLITE05/09/SUPERLITE
AN1946	Sensorless BLDC motor control and BEMF sampling methods with ST7MC
AN1953	PFC for ST7MC starter kit
AN1971	ST7LITE0 microcontrolled ballast
Programming and tools	
AN 978	ST7 Visual Develop software key debugging features
AN 983	Key features of the Cosmic ST7 C-compiler package
AN 985	Executing code in ST7 RAM
AN 986	Using the indirect addressing mode with ST7

Table 81. ST7 application notes (continued)

Identification	Description
AN 987	ST7 serial test controller programming
AN 988	Starting with ST7 assembly tool chain
AN1039	ST7 math utility routines
AN1071	Half duplex USB-to-serial bridge using the ST72611 USB microcontroller
AN1106	Translating assembly code from HC05 to ST7
AN1179	Programming ST7 Flash microcontrollers in remote ISP mode (In-situ programming)
AN1446	Using the ST72521 emulator to debug an ST72324 target application
AN1477	Emulated data EEPROM with Xflash memory
AN1527	Developing a USB smartcard reader with ST7SCR
AN1575	On-board programming methods for XFLASH and HDFLASH ST7 MCUs
AN1576	In-application programming (IAP) drivers for ST7 HDFLASH or XFLASH MCUs
AN1577	Device firmware upgrade (DFU) implementation for ST7 USB applications
AN1601	Software implementation for ST7DALI-EVAL
AN1603	Using the ST7 USB device firmware upgrade development kit (DFU-DK)
AN1635	ST7 customer ROM code release information
AN1754	Data logging program for testing ST7 applications via I ² C
AN1796	Field updates for FLASH based ST7 applications using a PC comm port
AN1900	Hardware implementation for ST7DALI-EVAL
AN1904	ST7MC three-phase AC induction motor control software library
AN1905	ST7MC three-phase BLDC motor control software library
System optimization	
AN1711	Software techniques for compensating ST7 ADC errors
AN1827	Implementation of SIGMA-DELTA ADC with ST7FLITE05/09
AN2003	PWM Management for 3-phase BLDC motor drives using the ST7FMC
AN2030	Back EMF detection during PWM on time by ST7MC

15 Known limitations

External interrupt 2 (ei2)

Whatever the external interrupt sensitivity configured through EICR1 register, ei2 cannot exit the MCU from Halt, Active-halt and AWUFH modes when a falling edge occurs.

Workaround

None

Obsolete Product(s) - Obsolete Product(s)
Obsolete Product(s) - Obsolete Product(s)

16 Revision history

Table 82. Document revision history

Date	Revision	Changes
06-Feb-06	1	Initial release
18-Apr-06	2	<p>Removed references to 3% RC Added note below Figure 4 Modified presentation of Section 4.3.1 Added notes to Section 6.2 (above Figure 9), replaced 8-bit calibration value to 10-bit calibration value and changed application note reference (AN2326 instead of AN1324) Modified Table 7: Clock register map and reset values and added bit 1 in the description of CKCNTCSR register Modified Figure 13 (added CKCNTCSR register) Added note 2 to EICRx description Modified caution in section 7.2 on page 25 Replaced $V_{IT+(LVD)}$ by $V_{IT+(LVD)}$ in Section : Monitoring the VDD main supply Modified LVDRF bit description in Section 7.4.4: Register description Replaced “oscillator” by “main oscillator” in the second paragraph of Section 8.4.2: Halt mode Added note 1 to Figure 23 and added note 5 to Figure 24 Modified Section 8.5: Auto-wake-up from Halt mode Replaced bit 1 by bit 2 for AWUF bit in Section 8.5.1: Register description Modified Section 9.1: Introduction. Modified Section : External interrupt function. Updated Section 9.5: Interrupts. Modified Section Table 47.: Operating conditions with low voltage detector (LVD). Modified Table 48: Auxiliary Voltage Detector (AVD) Thresholds. Modified Table 49: voltage drop between AVD flag set and LVD reset generation. Modified Table 50: Internal RC oscillator calibrated at 5 V. Modified Table 53: Supply current. Modified Table 54: On-chip peripherals. Modified Table 63: General characteristics. Modified Table 64: Output driving current. Modified Table 65: Asynchronous RESET pin characteristics. Modified Section 12.10: ADC characteristics. Added Figure 49. Modified Figure 61. Removed EMC protection circuitry in Figure 62 (device works correctly without these components). Added ECOPACK text in Section 13: Package characteristics. Modified first paragraph in Section 14: Device configuration and ordering information. Modified Table 79. Modified conditioning option in option list. Modified Section 14.3: Development tools. Added Section 14.4: ST7 application notes. Added Section : . Added erratasheet at the end of the document.</p>

Table 82. Document revision history (continued)

Date	Revision	Changes
18-Sep-06	3	<p>Modified description of AVD[1:0] bits in the AVDTRH register in Section 7.4.4</p> <p>Modified description of CNTR[11:0] bits in Section 10.2.6: Register description</p> <p>Modified values in Table 44</p> <p>LVD and AVD tables updated, Table 47, Table 48 and Table 49</p> <p>Internal RC oscillator data modified in Table 50 and new table added Table 51</p> <p>Typical data in Table 54 (on chip peripherals) modified</p> <p>EMC characteristics updated, Section 12.7</p> <p>R_{PU} data corrected in Table 63 including additional notes</p> <p>Output driving current table updated, Table 64</p> <p>R_{ON} data corrected in Table 65.</p> <p>Modified ADC accuracy tables in Section 12.10</p> <p>Section : updated</p> <p>Errata sheet removed from document</p> <p>Notes modified for low voltage detector Section 7.4.1</p> <p>Notes updated in Section 4.4 (I²C Interface)</p> <p>Thermal characteristics table updated, Table 74</p> <p>Modified option list on Section 14.2: Ordering information</p> <p>Modified Section 14.3: Development tools</p> <p>Modified text in Section :</p>
26-Jan-07	4	<p>Added -40°C to 125°C temperature range</p> <p>Modified note on ei4 in Table 9: interrupt mapping</p> <p>Added note 3 to Section 7.3.2: External Interrupt Control register 2 (EICR2)</p> <p>Added Figure 41 and Figure 40</p> <p>Added a note to LV DRF in Section 7.4.4: Register description</p> <p>Section 6.4.1: Introduction</p> <p>Modified Table 47 and Table 48</p> <p>Modified Table 50 Updated Table 53</p> <p>Updated Table 64</p> <p>Modified R_{AIN} and ADC accuracy tables in Section 12.10: ADC characteristics</p> <p>Modified Table 80</p> <p>Modified Table 79</p> <p>Modified option list on Figure 69: Option list</p>
06-Feb-2009	5	<p>Document reformatted.</p> <p>Replaced ST7ULTRALITE by ST7LITEUS2 and ST7LITEUS5.</p> <p>Removed limitations in user and in I²C mode from Section 15: Known limitations, and added External interrupt 2 (ei2).</p> <p>Added MCO on pin 3.</p> <p>Updated Section 12.3.2: Operating conditions with low voltage detector (LVD), Section 12.3.3: Auxiliary voltage detector (AVD) thresholds, Section 12.3.4: Internal RC oscillator, Section 12.4: Supply current characteristics, and Section 12.8.2: Output driving current characteristics.</p> <p>Updated internal RC prescaler to add 500 KHz.</p> <p>Updated ECOPACK text in Section 13.1: Package mechanical data. Added PDIP16 silhouette on cover page, and updated Table 73: 16-pin plastic dual in-line package, 300-mil width, package mechanical data and Figure 68: 16-pin plastic dual in-line package, 300-mil width, package outline.</p> <p>Changed order codes to die A version in Table 79: Supported order codes.</p> <p>Removed soldering information section.</p> <p>Updated option list.</p>

Please Read Carefully:

Information in this document is provided solely in connection with ST products. STMicroelectronics NV and its subsidiaries ("ST") reserve the right to make changes, corrections, modifications or improvements, to this document, and the products and services described herein at any time, without notice.

All ST products are sold pursuant to ST's terms and conditions of sale.

Purchasers are solely responsible for the choice, selection and use of the ST products and services described herein, and ST assumes no liability whatsoever relating to the choice, selection or use of the ST products and services described herein.

No license, express or implied, by estoppel or otherwise, to any intellectual property rights is granted under this document. If any part of this document refers to any third party products or services it shall not be deemed a license grant by ST for the use of such third party products or services, or any intellectual property contained therein or considered as a warranty covering the use in any manner whatsoever of such third party products or services or any intellectual property contained therein.

UNLESS OTHERWISE SET FORTH IN ST'S TERMS AND CONDITIONS OF SALE ST DISCLAIMS ANY EXPRESS OR IMPLIED WARRANTY WITH RESPECT TO THE USE AND/OR SALE OF ST PRODUCTS INCLUDING WITHOUT LIMITATION IMPLIED WARRANTIES OF MERCHANTABILITY, FITNESS FOR A PARTICULAR PURPOSE (AND THEIR EQUIVALENTS UNDER THE LAWS OF ANY JURISDICTION), OR INFRINGEMENT OF ANY PATENT, COPYRIGHT OR OTHER INTELLECTUAL PROPERTY RIGHT.

UNLESS EXPRESSLY APPROVED IN WRITING BY AN AUTHORIZED ST REPRESENTATIVE, ST PRODUCTS ARE NOT RECOMMENDED, AUTHORIZED OR WARRANTED FOR USE IN MILITARY, AIR CRAFT, SPACE, LIFE SAVING, OR LIFE SUSTAINING APPLICATIONS, NOR IN PRODUCTS OR SYSTEMS WHERE FAILURE OR MALFUNCTION MAY RESULT IN PERSONAL INJURY, DEATH, OR SEVERE PROPERTY OR ENVIRONMENTAL DAMAGE. ST PRODUCTS WHICH ARE NOT SPECIFIED AS "AUTOMOTIVE GRADE" MAY ONLY BE USED IN AUTOMOTIVE APPLICATIONS AT USER'S OWN RISK.

Resale of ST products with provisions different from the statements and/or technical features set forth in this document shall immediately void any warranty granted by ST for the ST product or service described herein and shall not create or extend in any manner whatsoever, any liability of ST.

ST and the ST logo are trademarks or registered trademarks of ST in various countries.

Information in this document supersedes and replaces all information previously supplied.

The ST logo is a registered trademark of STMicroelectronics. All other names are the property of their respective owners.

© 2009 STMicroelectronics - All rights reserved

STMicroelectronics group of companies

Australia - Belgium - Brazil - Canada - China - Czech Republic - Finland - France - Germany - Hong Kong - India - Israel - Italy - Japan - Malaysia - Malta - Morocco - Singapore - Spain - Sweden - Switzerland - United Kingdom - United States of America

www.st.com

Looking for pricing, stock, or lifecycle information?

Click below to explore more details on WIN SOURCE:

- ⊖ [View ST7FLITEUS2M6TR](#) on WIN SOURCE
- ⊖ [STMicroelectronics](#) Information

Optimize Your Supply Chain with WIN SOURCE Solutions

- ✓ Global Sourcing Solution
- ✓ Obsolete Management
- ✓ Cost Control Management
- ✓ Shortage Management
- ✓ Alternative Solution
- ✓ Excess Inventory Management