



**THE DATASHEET OF  
TPS54233QDRQ1**



## 2-A, 28-V INPUT, STEP-DOWN DC/DC CONVERTER WITH ECO-MODE™

Check for Samples: [TPS54233-Q1](#)

### FEATURES

- Qualified for Automotive Applications
- AEC-Q100 Test Guidance With the Following Results:
  - Device Temperature Grade1:  $-40^{\circ}\text{C}$  to  $+125^{\circ}\text{C}$  Ambient Operating Temperature Range
  - Device HBM ESD Classification Level H2
  - Device CDM ESD Classification Level C3B
- 3.5 V to 28 V Input Voltage Range
- Adjustable Output Voltage Down to 0.8 V
- Integrated 80-m $\Omega$  High-Side MOSFET Supports up to 2-A Continuous Output Current
- High Efficiency at Light Loads With a Pulse-Skipping Eco-mode™
- Fixed 300-kHz Switching Frequency
- Typical 1  $\mu\text{A}$  Shutdown Quiescent Current
- Adjustable Slow Start Limits Inrush Currents
- Programmable UVLO Threshold
- Overvoltage Transient Protection
- Cycle by Cycle Current Limit, Frequency Fold Back and Thermal Shutdown Protection
- Available in the SOIC8 Package
- Supported by SwitcherPro™ Software Tool (<http://focus.ti.com/docs/toolsw/folders/print/switcherpro.html>)

### APPLICATIONS

- LCD Displays, Peripherals, and Battery Chargers
- Car Audio Power Supplies
- 5V, 12V and 24V Distributed Power Systems

### DESCRIPTION

The TPS54233-Q1 is a 28 V, 2 A non-synchronous buck converter that integrates a low  $R_{\text{DS(on)}}$  high side MOSFET. To increase efficiency at light loads, a pulse skipping Eco-mode™ feature is automatically activated. Furthermore, the 1  $\mu\text{A}$  shutdown supply current allows the device to be used in battery powered applications. Current mode control with internal slope compensation simplifies the external compensation calculations and reduces component count while allowing the use of ceramic output capacitors. A resistor divider programs the Hysteresis of the input under-voltage lockout. An overvoltage transient protection circuit limits voltage overshoots during startup and transient conditions. A cycle by cycle current limit scheme, frequency fold back and thermal shutdown protect the device and the load in the event of an overload condition. The TPS54233-Q1 is available in an 8-pin SOIC package that has been internally optimized to improve thermal performance.

SIMPLIFIED SCHEMATIC

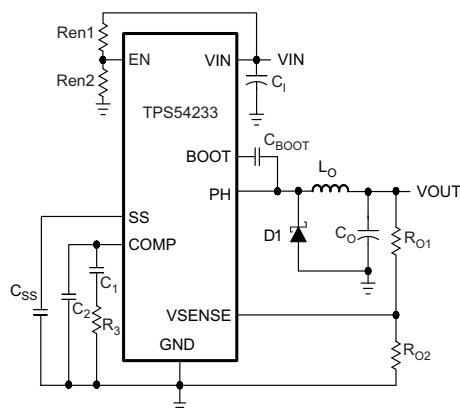

EFFICIENCY

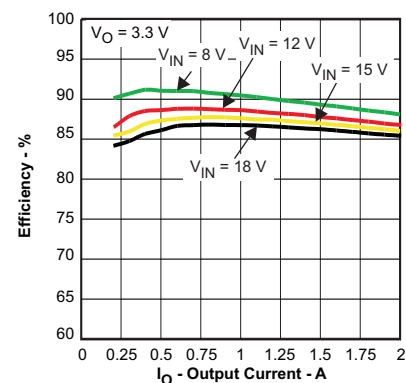

Please be aware that an important notice concerning availability, standard warranty, and use in critical applications of Texas Instruments semiconductor products and disclaimers thereto appears at the end of this data sheet.

Eco-mode, SwitcherPro, PowerPAD are trademarks of Texas Instruments.



These devices have limited built-in ESD protection. The leads should be shorted together or the device placed in conductive foam during storage or handling to prevent electrostatic damage to the MOS gates.

## DESCRIPTION CONTINUED

For additional design needs, see:

	TPS54231-Q1 (Preview)	TPS54232-Q1 (Preview)	TPS54233-Q1	TPS54331-Q1 (Preview)	TPS54332-Q1 (Preview)
$I_O(\text{Max})$	2A	2A	2A	3A	3.5A
Input Voltage Range	3.5V - 28V	3.5V - 28V	3.5V - 28V	3.5V - 28V	3.5V - 28V
Switching Freq. (Typ)	570kHz	1000kHz	285kHz	570kHz	1000kHz
Switch Current Limit (Min)	2.3A	2.3A	2.3A	3.5A	4.2A
Pin/Package	8SOIC	8SOIC	8SOIC	8SOIC	8SO PowerPAD™

## ORDERING INFORMATION<sup>(1)</sup>

$T_A$	PACKAGE	SWITCHING FREQUENCY	PART NUMBER <sup>(2)</sup>
-40°C to +125°C	8 pin SOIC	300 kHz	TPS54233QDRQ1

(1) For the most current package and ordering information, see the Package Option Addendum at the end of this document, or see the TI web site at [www.ti.com](http://www.ti.com).

(2) See applications section of data sheet for layout information.

## ABSOLUTE MAXIMUM RATINGS<sup>(1)</sup>

over operating free-air temperature range (unless otherwise noted)

		VALUE		UNIT
		MIN	MAX	
Input Voltage	VIN	-0.3	30	V
	EN	-0.3	6	
	BOOT		38	
	VSENSE	-0.3	3	
	COMP	-0.3	3	
	SS	-0.3	3	
Output Voltage	BOOT-PH		8	V
	PH	-0.6	30	
	PH (10 ns transient from ground to negative peak)		-5	
Source Current	EN		100	μA
	BOOT		100	mA
	VSENSE		10	μA
	PH		6	A
Sink Current	VIN		6	A
	COMP		100	μA
	SS		200	
Electrostatic Discharge	Human body model (HBM) AEC-Q100 Classification Level H2		2	kV
	Charged device model (CDM) AEC-Q100 Classification Level C3B		750	V
Operating Junction Temperature		-40	+150	°C
Storage Temperature		-65	+150	°C

(1) Stresses beyond those listed under absolute maximum ratings may cause permanent damage to the device. These are stress ratings only, and functional operation of the device at these or any other conditions beyond those indicated under recommended operating conditions is not implied. Exposure to absolute-maximum-rated conditions for extended periods may affect device reliability.

## THERMAL INFORMATION

THERMAL METRIC <sup>(1)</sup>		TPS54233-Q1	UNITS
		D (8 PINS)	
$\theta_{JA}$	Junction-to-ambient thermal resistance	116.7	°C/W
$\theta_{JcTop}$	Junction-to-case (top) thermal resistance	62.4	
$\theta_{JB}$	Junction-to-board thermal resistance	57.0	
$\Psi_{JT}$	Junction-to-top characterization parameter	14.5	
$\Psi_{JB}$	Junction-to-board characterization parameter	56.5	
$\theta_{JcBot}$	Junction-to-case (bottom) thermal resistance	n/a	

(1) For more information about traditional and new thermal metrics, see the *IC Package Thermal Metrics* application report, [SPRA953](#).

## RECOMMENDED OPERATING CONDITIONS

over operating free-air temperature range (unless otherwise noted)

	MIN	TYP	MAX	UNIT
Operating Input Voltage on (VIN pin)	3.5		28	V
Operating junction temperature, T <sub>J</sub>	-40		+150	°C

## ELECTRICAL CHARACTERISTICS

T<sub>A</sub> = -40°C to +125°C, VIN = 3.5V to 28V (unless otherwise noted)

DESCRIPTION	TEST CONDITIONS	MIN	TYP	MAX	UNIT
<b>SUPPLY VOLTAGE (VIN PIN)</b>					
Internal undervoltage lockout threshold	Rising and Falling			3.5	V
Shutdown supply current	EN = 0V, VIN = 12V, -40°C to +85°C		1	4	μA
Operating – non switching supply current	VSENSE = 0.85 V		75	110	μA
<b>ENABLE AND UVLO (EN PIN)</b>					
Enable threshold	Rising and Falling		1.25	1.35	V
Input current	Enable threshold – 50 mV		-1		μA
Input current	Enable threshold + 50 mV		-4		μA
<b>VOLTAGE REFERENCE</b>					
Voltage reference		0.772	0.8	0.828	V
<b>HIGH-SIDE MOSFET</b>					
On resistance	BOOT-PH = 3 V, VIN = 3.5 V		115	200	mΩ
	BOOT-PH = 6 V, VIN = 12 V		80	150	
<b>ERROR AMPLIFIER</b>					
Error amplifier transconductance (gm)	-2 μA < I <sub>(COMP)</sub> < 2 μA, V <sub>(COMP)</sub> = 1 V		92		μmhos
Error amplifier DC gain <sup>(1)</sup>	VSENSE = 0.8 V		800		V/V
Error amplifier unity gain bandwidth <sup>(1)</sup>	5 pF capacitance from COMP to GND pins		2.7		MHz
Error amplifier source/sink current	V <sub>(COMP)</sub> = 1 V, 100 mV overdrive		±7		μA
Switch current to COMP transconductance	VIN = 12 V		9		A/V
<b>SWITCHING FREQUENCY</b>					
TPS54233-Q1 Switching Frequency	VIN = 12V	210	300	390	kHz
Minimum controllable on time	VIN = 12V, +25°C		105	130	ns
Maximum controllable duty ratio <sup>(1)</sup>	BOOT-PH = 6 V	90%	93%		
<b>PULSE SKIPPING ECO-MODE™</b>					
Pulse skipping Eco-mode™ switch current threshold			100		mA
<b>CURRENT LIMIT</b>					
Current limit threshold	VIN = 12 V	2.3	3.5		A

(1) Specified by design

### ELECTRICAL CHARACTERISTICS (continued)

T<sub>A</sub> = -40°C to +125°C, V<sub>IN</sub> = 3.5V to 28V (unless otherwise noted)

DESCRIPTION	TEST CONDITIONS	MIN	TYP	MAX	UNIT
<b>THERMAL SHUTDOWN</b>					
Thermal Shutdown			+165		°C
<b>SLOW START (SS PIN)</b>					
Charge current	V <sub>(SS)</sub> = 0.4 V		2		μA
SS to VSENSE matching	V <sub>(SS)</sub> = 0.4 V		10		mV

### DEVICE INFORMATION

#### PIN ASSIGNMENTS

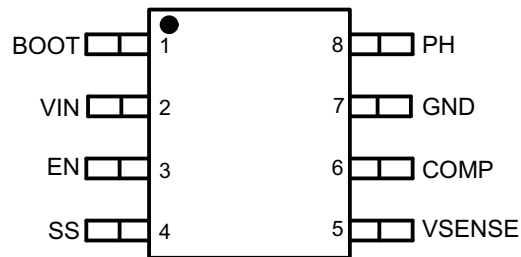

#### PIN FUNCTIONS

PIN		DESCRIPTION
NAME	NO.	
BOOT	1	A 0.1 μF bootstrap capacitor is required between BOOT and PH. If the voltage on this capacitor falls below the minimum requirement, the high-side MOSFET is forced to switch off until the capacitor is refreshed.
VIN	2	Input supply voltage, 3.5 V to 28 V.
EN	3	Enable pin. Pull below 1.25V to disable. Float to enable. Programming the input undervoltage lockout with two resistors is recommended.
SS	4	Slow start pin. An external capacitor connected to this pin sets the output rise time.
VSENSE	5	Inverting node of the gm error amplifier.
COMP	6	Error amplifier output, and input to the PWM comparator. Connect frequency compensation components to this pin.
GND	7	Ground.
PH	8	The source of the internal high-side power MOSFET.

FUNCTIONAL BLOCK DIAGRAM

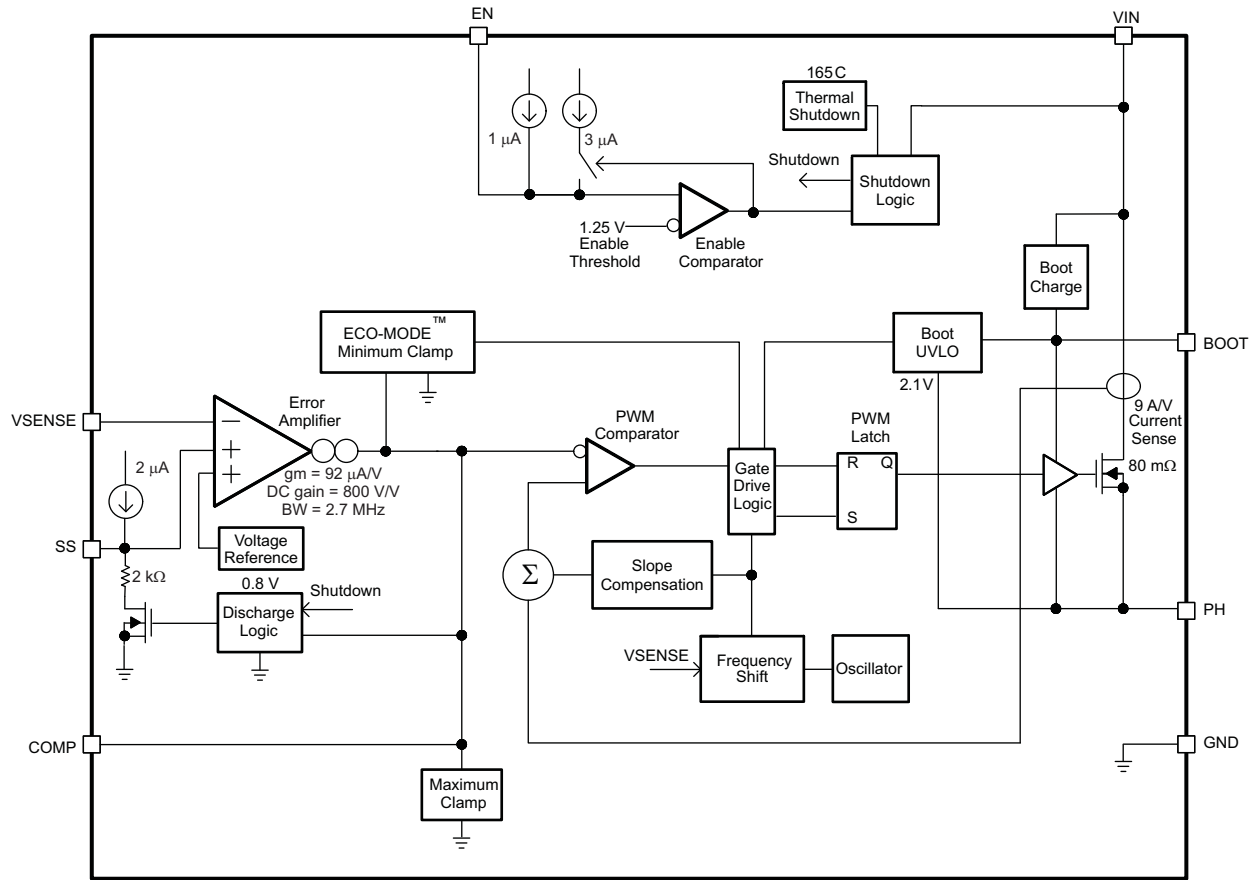

TYPICAL CHARACTERISTICS

CHARACTERIZATION CURVES

ON RESISTANCE vs JUNCTION TEMPERATURE

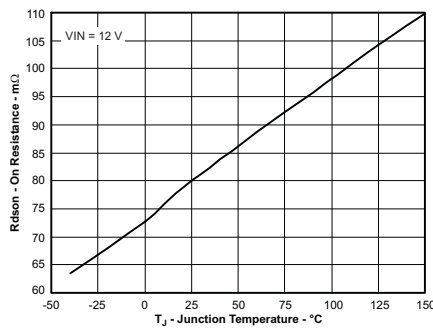

Figure 1.

SHUTDOWN QUIESCENT CURRENT vs INPUT VOLTAGE

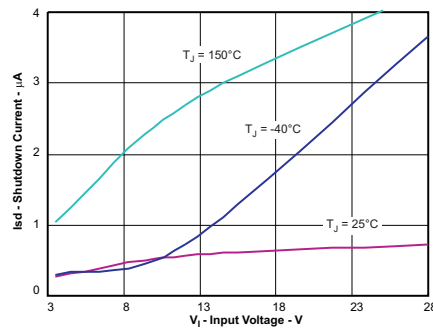

Figure 2.

SWITCHING FREQUENCY vs JUNCTION TEMPERATURE

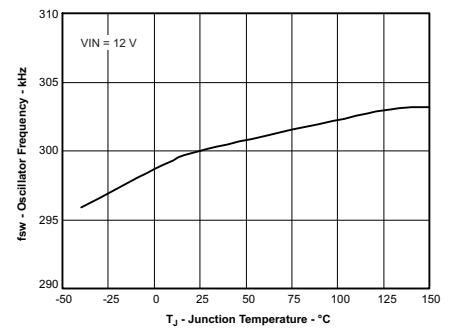

Figure 3.

**TYPICAL CHARACTERISTICS (continued)**

**VOLTAGE REFERENCE  
vs  
JUNCTION TEMPERATURE**

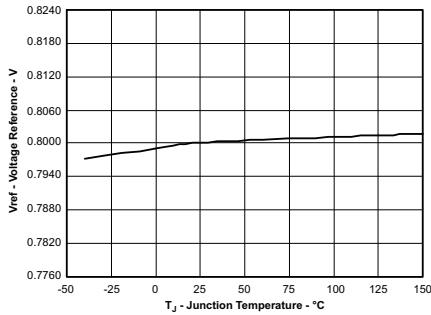

Figure 4.

**MINIMUM CONTROLLABLE ON TIME  
vs  
JUNCTION TEMPERATURE**

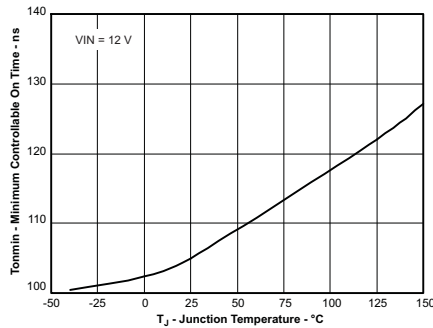

Figure 5.

**MINIMUM CONTROLLABLE DUTY RATIO  
vs  
JUNCTION TEMPERATURE**

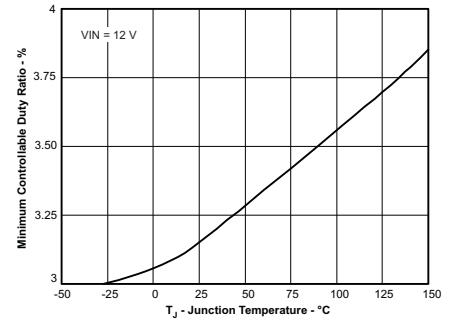

Figure 6.

**SS CHARGE CURRENT  
vs  
JUNCTION TEMPERATURE**

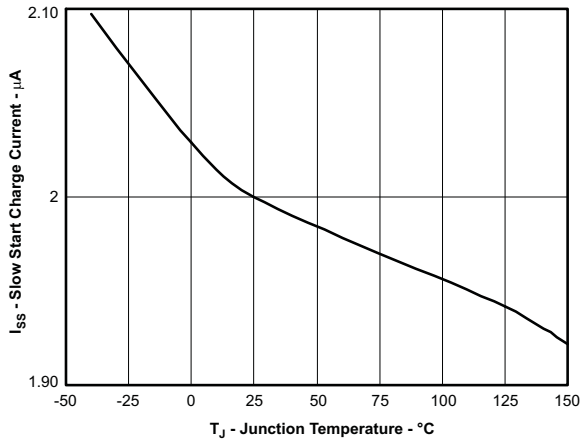

Figure 7.

**CURRENT LIMIT THRESHOLD  
vs  
INPUT VOLTAGE**

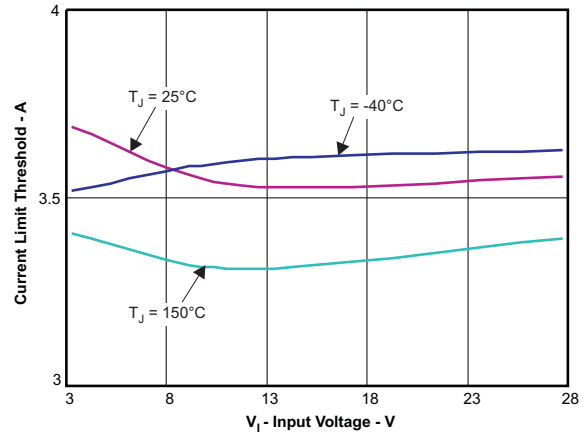

Figure 8.

**SUPPLEMENTAL APPLICATION CURVES**

**TYPICAL MAXIMUM OUTPUT VOLTAGE  
vs  
INPUT VOLTAGE**

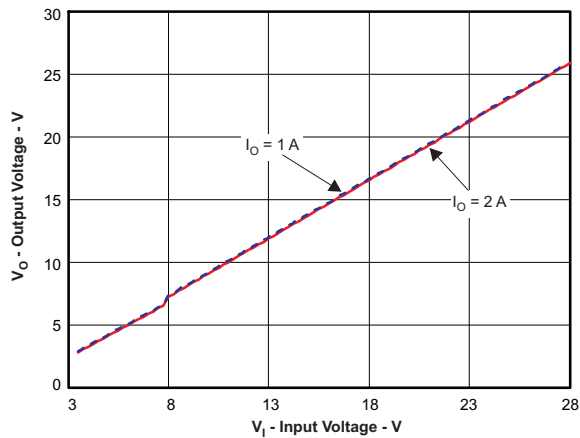

Figure 9.

**MAXIMUM POWER DISSIPATION  
vs  
JUNCTION TEMPERATURE**

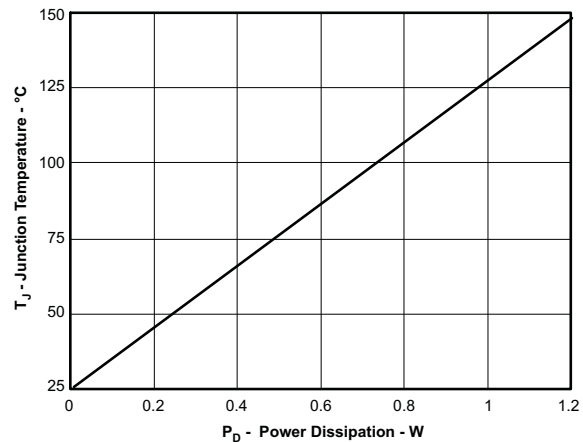

Figure 10.

## TYPICAL CHARACTERISTICS (continued)

### OVERVIEW

The TPS54233-Q1 is a 28 V, 2 A, step-down (buck) converter with an integrated high-side n-channel MOSFET. To improve performance during line and load transients, the device implements a constant frequency, current mode control which reduces output capacitance and simplifies external frequency compensation design. The TPS54233-Q1 has a pre-set switching frequency of 300 kHz.

The TPS54233-Q1 needs a minimum input voltage of 3.5 V to operate normally. The EN pin has an internal pull-up current source that can be used to adjust the input voltage under-voltage lockout (UVLO) with two external resistors. In addition, the pull-up current provides a default condition when the EN pin is floating for the device to operate. The operating current is 75  $\mu$ A typically when not switching and under no load. When the device is disabled, the supply current is 1  $\mu$ A typically.

The integrated 80 m $\Omega$  high-side MOSFET allows for high efficiency power supply designs with continuous output currents up to 2 A.

The TPS54233-Q1 reduces the external component count by integrating the boot recharge diode. The bias voltage for the integrated high-side MOSFET is supplied by an external capacitor on the BOOT to PH pin. The boot capacitor voltage is monitored by an UVLO circuit and will turn the high-side MOSFET off when the voltage falls below a preset threshold of 2.1 V typically. The output voltage can be stepped down to as low as the reference voltage.

By adding an external capacitor, the slow start time of the TPS54233-Q1 can be adjustable which enables flexible output filter selection.

To improve the efficiency at light load conditions, the TPS54233-Q1 enters a special pulse skipping Eco-mode™ when the peak inductor current drops below 100 mA typically.

The frequency foldback reduces the switching frequency during startup and over current conditions to help control the inductor current. The thermal shut down gives the additional protection under fault conditions.

## DETAILED DESCRIPTION

### FIXED FREQUENCY PWM CONTROL

The TPS54233-Q1 uses a fixed frequency, peak current mode control. The internal switching frequency of the TPS54233-Q1 is fixed at 300kHz.

### ECO-MODE™

The TPS54233-Q1 is designed to operate in pulse skipping Eco-mode™ at light load currents to boost light load efficiency. When the peak inductor current is lower than 100 mA typically, the COMP pin voltage falls to 0.5V typically and the device enters Eco-mode™. When the device is in Eco-mode™, the COMP pin voltage is clamped at 0.5V internally which prevents the high side integrated MOSFET from switching. The peak inductor current must rise above 100mA for the COMP pin voltage to rise above 0.5V and exit Eco-mode™. Since the integrated current comparator catches the peak inductor current only, the average load current entering Eco-mode™ varies with the applications and external output filters.

### VOLTAGE REFERENCE ( $V_{ref}$ )

The voltage reference system produces a  $\pm 2\%$  initial accuracy voltage reference ( $\pm 3.5\%$  over temperature) by scaling the output of a temperature stable bandgap circuit. The typical voltage reference is designed at 0.8V.

### BOOTSTRAP VOLTAGE (BOOT)

The TPS54233-Q1 has an integrated boot regulator and requires a 0.1  $\mu$ F ceramic capacitor between the BOOT and PH pin to provide the gate drive voltage for the high-side MOSFET. A ceramic capacitor with an X7R or X5R grade dielectric is recommended because of the stable characteristics over temperature and voltage. To improve drop out, the TPS54233-Q1 is designed to operate at 100% duty cycle as long as the BOOT to PH pin voltage is greater than 2.1V typically.

## ENABLE AND ADJUSTABLE INPUT UNDER-VOLTAGE LOCKOUT (VIN UVLO)

The EN pin has an internal pull-up current source that provides the default condition of the TPS54233-Q1 operating when the EN pin floats.

The TPS54233-Q1 is disabled when the VIN pin voltage falls below internal VIN UVLO threshold. It is recommended to use an external VIN UVLO to add Hysteresis unless VIN is greater than ( $V_{OUT} + 2V$ ). To adjust the VIN UVLO with Hysteresis, use the external circuitry connected to the EN pin as shown in Figure 11. Once the EN pin voltage exceeds 1.25V, an additional 3  $\mu A$  of hysteresis is added. Use Equation 1 and Equation 2 to calculate the resistor values needed for the desired VIN UVLO threshold voltages. The  $V_{START}$  is the input start threshold voltage, the  $V_{STOP}$  is the input stop threshold voltage and the  $V_{EN}$  is the enable threshold voltage of 1.25 V. The  $V_{STOP}$  should always be greater than 3.5 V.

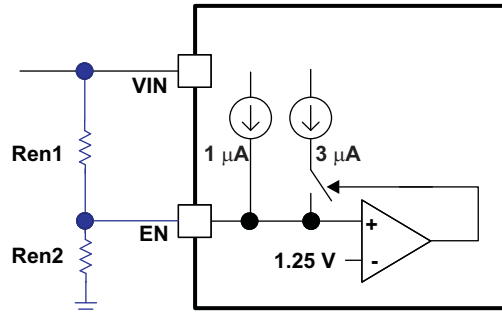

Figure 11. Adjustable Input Undervoltage Lockout

$$R_{en1} = \frac{V_{START} - V_{STOP}}{3 \mu A} \quad (1)$$

$$R_{en2} = \frac{V_{EN}}{\frac{V_{START} - V_{EN}}{R_{en1}} + 1 \mu A} \quad (2)$$

## PROGRAMMABLE SLOW START USING SS PIN

It is recommended to program the slow start time externally because no slow start time is implemented internally. The TPS54233-Q1 effectively uses the lower voltage of the internal voltage reference or the SS pin voltage as the power supply's reference voltage fed into the error amplifier and will regulate the output accordingly. A capacitor ( $C_{SS}$ ) on the SS pin to ground implements a slow start time. The TPS54233-Q1 has an internal pull-up current source of 2  $\mu A$  that charges the external slow start capacitor. The equation for the slow start time (10% to 90%) is shown in Equation 3. The  $V_{ref}$  is 0.8 V and the  $I_{SS}$  current is 2  $\mu A$ .

$$T_{SS} (ms) = \frac{C_{SS} (nF) \times V_{ref} (V)}{I_{SS} (\mu A)} \quad (3)$$

The slow start time should be set between 1ms to 10ms to ensure good start-up behavior. The slow start capacitor should be no more than 27 nF.

If during normal operation, the input voltage drops below the VIN UVLO threshold, or the EN pin is pulled below 1.25 V, or a thermal shutdown event occurs, the TPS54233-Q1 stops switching.

## ERROR AMPLIFIER

The TPS54233-Q1 has a transconductance amplifier for the error amplifier. The error amplifier compares the VSENSE voltage to the internal effective voltage reference presented at the input of the error amplifier. The transconductance of the error amplifier is 92  $\mu A/V$  during normal operation. Frequency compensation components are connected between the COMP pin and ground.

## SLOPE COMPENSATION

To prevent the sub-harmonic oscillations when operating the device at duty cycles greater than 50%, the TPS54233-Q1 adds a built-in slope compensation which is a compensating ramp to the switch current signal.

## CURRENT MODE COMPENSATION DESIGN

To simplify design efforts using the TPS54233-Q1, the typical designs for common applications are listed in [Table 1](#). For designs using ceramic output capacitors, proper derating of ceramic output capacitance is recommended when doing the stability analysis. This is because the actual ceramic capacitance drops considerably from the nominal value when the applied voltage increases. Advanced users may refer to the *Step by Step Design Procedure* in the Application Information section for the detailed guidelines or use SwitcherPro™ Software tool (<http://focus.ti.com/docs/toolsw/folders/print/switcherpro.html>).

**Table 1. Typical Designs (Referring to Simplified Schematic on page 1)**

V <sub>IN</sub> (V)	V <sub>OUT</sub> (V)	F <sub>sw</sub> (kHz)	L <sub>o</sub> (μH)	C <sub>o</sub>	R <sub>O1</sub> (kΩ)	R <sub>O2</sub> (kΩ)	C <sub>2</sub> (pF)	C <sub>1</sub> (pF)	R <sub>3</sub> (kΩ)
12	5	300	22	Ceramic 47 μF	10	1.91	68	1800	21
12	3.3	300	15	Ceramic 47μF	10.2	3.24	47	4700	21
12	1.8	300	10	Ceramic 100 μF x 2	10	8.06	100	4700	21
12	0.9	300	6.8	Ceramic 100 μFx2	10	80.6	100	4700	21
12	5	300	22	Aluminum 330 μF/160 mΩ	10	1.91	56	220	40.2
12	3.3	300	15	Aluminum 470 μF/160 mΩ	10.2	3.24	220	220	30.9
12	1.8	300	10	SP 220 μF/12 mΩ	10	8.06	100	4700	40.2
12	0.9	300	6.8	SP 220 μF/12 mΩ	10	80.6	100	1800	21

## OVERCURRENT PROTECTION AND FREQUENCY SHIFT

The TPS54233-Q1 implements current mode control that uses the COMP pin voltage to turn off the high-side MOSFET on a cycle by cycle basis. Every cycle the switch current and the COMP pin voltage are compared; when the peak inductor current intersects the COMP pin voltage, the high-side switch is turned off. During overcurrent conditions that pull the output voltage low, the error amplifier responds by driving the COMP pin high, causing the switch current to increase. The COMP pin has a maximum clamp internally, which limit the output current.

The TPS54233-Q1 provides robust protection during short circuits. There is potential for overcurrent runaway in the output inductor during a short circuit at the output. The TPS54233-Q1 solves this issue by increasing the off time during short circuit conditions by lowering the switching frequency. The switching frequency is divided by 8, 4, 2, and 1 as the voltage ramps from 0 V to 0.8 V on VSENSE pin. The relationship between the switching frequency and the VSENSE pin voltage is shown in [Table 2](#).

**Table 2. Switching Frequency Conditions**

SWITCHING FREQUENCY	VSENSE PIN VOLTAGE
300 kHz	VSENSE ≥ 0.6 V
300 kHz / 2	0.6 V > VSENSE ≥ 0.4 V
300 kHz / 4	0.4 V > VSENSE ≥ 0.2 V
300 kHz / 8	0.2 V > VSENSE

## OVERVOLTAGE TRANSIENT PROTECTION

The TPS54233-Q1 incorporates an overvoltage transient protection (OVTP) circuit to minimize output voltage overshoot when recovering from output fault conditions or strong unload transients. The OVTP circuit includes an overvoltage comparator to compare the VSENSE pin voltage and internal thresholds. When the VSENSE pin voltage goes above 109% × V<sub>ref</sub>, the high-side MOSFET will be forced off. When the VSENSE pin voltage falls below 107% × V<sub>ref</sub>, the high-side MOSFET will be enabled again.

## THERMAL SHUTDOWN

The device implements an internal thermal shutdown to protect itself if the junction temperature exceeds 165°C. The thermal shutdown forces the device to stop switching when the junction temperature exceeds the thermal trip threshold. Once the die temperature decreases below 165°C, the device reinitiates the power up sequence.

APPLICATION INFORMATION

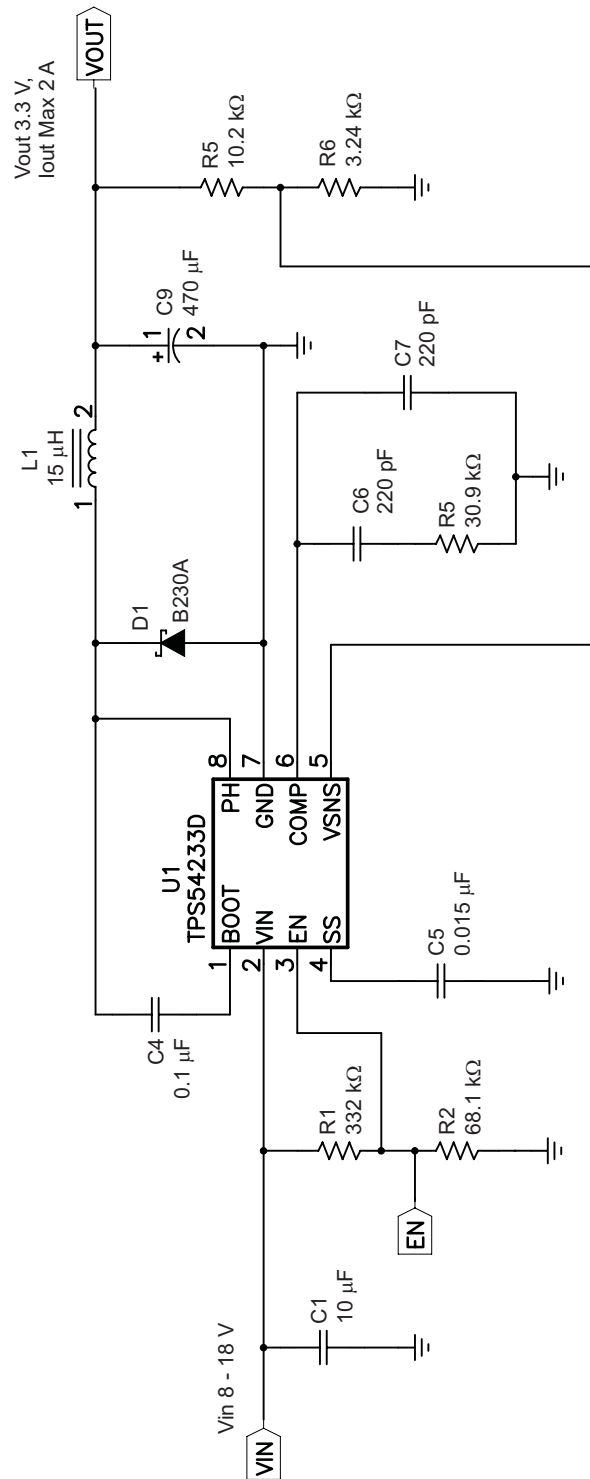

Figure 12. Typical Application Schematic

## STEP BY STEP DESIGN PROCEDURE

The following design procedure can be used to select component values for the TPS54233-Q1. Alternately, the SwitcherPro™ Software may be used to generate a complete design. The SwitcherPro™ Software uses an iterative design procedure and accesses a comprehensive database of components when generating a design. This section presents a simplified discussion of the design process.

To begin the design process a few parameters must be decided upon. The designer needs to know the following:

- Input voltage range
- Output voltage
- Input ripple voltage
- Output ripple voltage
- Output current rating
- Operating frequency

For this design example, use the following as the input parameters

**Table 3. Design Parameters**

DESIGN PARAMETER	EXAMPLE VALUE
Input voltage range	8 V to 18 V
Output voltage	3.3 V
Input ripple voltage	300 mV
Output ripple voltage	100 mV
Output current rating	2 A
Operating Frequency	300 kHz

## SWITCHING FREQUENCY

The switching frequency for the TPS54233-Q1 is fixed at 300 kHz.

## OUTPUT VOLTAGE SET POINT

The output voltage of the TPS54233-Q1 is externally adjustable using a resistor divider network. In the application circuit of [Figure 12](#), this divider network is comprised of R5 and R6. The relationship of the output voltage to the resistor divider is given by [Equation 4](#) and [Equation 5](#):

$$R6 = \frac{R5 \times V_{REF}}{V_{OUT} - V_{REF}} \quad (4)$$

$$V_{OUT} = V_{REF} \times \left[ \frac{R5}{R6} + 1 \right] \quad (5)$$

Choose R5 to be approximately 10 kΩ. Slightly increasing or decreasing R5 can result in closer output voltage matching when using standard value resistors. In this design, R5 = 10.2 kΩ and R6 = 3.24 kΩ, resulting in a 3.31 V output voltage.

## INPUT CAPACITORS

The TPS54233-Q1 requires an input decoupling capacitor and depending on the application, a bulk input capacitor. The typical recommended value for the decoupling capacitor is 10 μF. A high-quality ceramic type X5R or X7R is recommended. The voltage rating should be greater than the maximum input voltage. A smaller value may be used as long as all other requirements are met; however 10 μF has been shown to work well in a wide variety of circuits. Additionally, some bulk capacitance may be needed, especially if the TPS54233-Q1 circuit is not located within about 2 inches from the input voltage source. The value for this capacitor is not critical but should be rated to handle the maximum input voltage including ripple voltage, and should filter the output so that input ripple voltage is acceptable. For this design two 4.7 μF capacitors are used for the input decoupling capacitor. They are X7R dielectric rated for 50 V. The equivalent series resistance (ESR) is approximately 2 mΩ, and the current rating is 3 A. Additionally, a small 0.01 μF capacitor is included for high frequency filtering.

This input ripple voltage can be approximated by [Equation 6](#)

$$\Delta V_{IN} = \frac{I_{OUT(MAX)} \times 0.25}{C_{BULK} \times f_{SW}} + (I_{OUT(MAX)} \times ESR_{MAX}) \quad (6)$$

Where  $I_{OUT(MAX)}$  is the maximum load current,  $f_{SW}$  is the switching frequency,  $C_{BULK}$  is the bulk capacitor value and  $ESR_{MAX}$  is the maximum series resistance of the bulk capacitor.

The maximum RMS ripple current also needs to be checked. For worst case conditions, this can be approximated by [Equation 7](#)

$$I_{CIN} = \frac{I_{OUT(MAX)}}{2} \quad (7)$$

In this case, the input ripple voltage would be 143 mV and the RMS ripple current would be 1.5 A. It is also important to note that the actual input voltage ripple will be greatly affected by parasitics associated with the layout and the output impedance of the voltage source. The actual input voltage ripple for this circuit is shown in [Design Parameters](#) and is larger than the calculated value. This measured value is still below the specified input limit of 300 mV. The maximum voltage across the input capacitors would be  $V_{IN\ max}$  plus  $\Delta V_{IN}/2$ . The chosen bulk and bypass capacitors are each rated for 50 V and the ripple current capacity is greater than 3 A, both providing ample margin. It is important that the maximum ratings for voltage and current are not exceeded under any circumstance.

## OUTPUT FILTER COMPONENTS

Two components need to be selected for the output filter, L1 and C2. Since the TPS54233-Q1 is an externally compensated device, a wide range of filter component types and values can be supported.

### Inductor Selection

To calculate the minimum value of the output inductor, use [Equation 8](#)

$$L_{MIN} = \frac{V_{OUT(MAX)} \times (V_{IN(MAX)} - V_{OUT})}{V_{IN(MAX)} \times K_{IND} \times I_{OUT} \times F_{SW}} \quad (8)$$

$K_{IND}$  is a coefficient that represents the amount of inductor ripple current relative to the maximum output current. This value is at the discretion of the designer; however, the following guidelines may be used. For designs using low ESR output capacitors such as ceramics, a value as high as  $K_{IND} = 0.3$  may be used. When using higher ESR output capacitors,  $K_{IND} = 0.2$  yields better results.

For this design example, use  $K_{IND} = 0.3$  and the minimum inductor value is calculated to be 14.97 $\mu$ H. For this design, the closest value 15 $\mu$ H was chosen.

For the output filter inductor, it is important that the RMS current and saturation current ratings not be exceeded. The RMS inductor current can be found from [Equation 9](#)

$$I_{L(RMS)} = \sqrt{I_{OUT(MAX)}^2 + \frac{1}{12} \times \left( \frac{V_{OUT} \times (V_{IN(MAX)} - V_{OUT})}{V_{IN(MAX)} \times L_{OUT} \times F_{SW} \times 0.7} \right)^2} \quad (9)$$

and the peak inductor current can be determined with [Equation 10](#)

$$I_{L(PK)} = I_{OUT(MAX)} + \frac{V_{OUT} \times (V_{IN(MAX)} - V_{OUT})}{1.4 \times V_{IN(MAX)} \times L_{OUT} \times F_{SW}} \quad (10)$$

For this design, the RMS inductor current is 2.02 A and the peak inductor current is 2.43 A. The chosen inductor is a Coilcraft MSS1038-153ML 15  $\mu$ H. It has a saturation current rating of 3.86 A and an RMS current rating of 3.8 A, meeting these requirements. Smaller or larger inductor values can be used depending on the amount of ripple current the designer wishes to allow so long as the other design requirements are met. Larger value inductors will have lower ac current and result in lower output voltage ripple, while smaller inductor values will increase ac current and output voltage ripple. Inductor values for use with the TPS54233-Q1 are in the range of 6.8  $\mu$ H to 47  $\mu$ H.

## Capacitor Selection

The important design factors for the output capacitor are dc voltage rating, ripple current rating, and equivalent series resistance (ESR). The dc voltage and ripple current ratings cannot be exceeded. The ESR is important because along with the inductor current it determines the amount of output ripple voltage. The actual value of the output capacitor is not critical, but some practical limits do exist. Consider the relationship between the desired closed loop crossover frequency of the design and LC corner frequency of the output filter. In general, it is desirable to keep the closed loop crossover frequency at less than 1/5 of the switching frequency. With high switching frequencies such as the 300 kHz frequency of this design, internal circuit limitations of the TPS54233-Q1 limit the practical maximum crossover frequency to about 25 kHz. In general, the closed loop crossover frequency should be higher than the corner frequency determined by the load impedance and the output capacitor. This limits the minimum capacitor value for the output filter to:

$$C_{O\_min} = 1 / (2 \times \pi \times R_O \times f_{CO\_max}) \quad (11)$$

Where  $R_O$  is the output load impedance ( $V_O/I_O$ ) and  $f_{CO}$  is the desired crossover frequency. For a desired maximum crossover of 25 kHz the minimum value for the output capacitor is around 3.8 $\mu$ F. This may not satisfy the output ripple voltage requirement. The output ripple voltage consists of two components; the voltage change due to the charge and discharge of the output filter capacitance and the voltage change due to the ripple current times the ESR of the output filter capacitor. The output ripple voltage can be estimated by:

$$V_{OPP} = I_{LPP} \left[ \frac{(D - 0.5)}{4 \times F_{SW} \times C_O} + R_{ESR} \right] \quad (12)$$

Where  $N_C$  is the number of output capacitors in parallel.

The maximum ESR of the output capacitor is determined by the amount of allowable output ripple as specified in the initial design parameters; so the maximum specified ESR as listed in the capacitor data sheet is given by [Equation 13](#):

$$ESR_{max} = \frac{V_{OPPMAX}}{I_{LPP}} - \frac{(D - 0.5)}{4 \times F_{SW} \times C_O} \quad (13)$$

Where  $\Delta V_{p-p}$  is the desired peak-to-peak output ripple.

To meet the 100 mV p-p ripple requirement, a single 470  $\mu$ F aluminum electrolytic output capacitor is chosen for C9. This is a Panasonic, EEVFK1A471P rated at 10 V with a maximum ESR of 160 m $\Omega$  and a ripple current rating of 600 mA.

The maximum RMS output ripple current can be calculated using [Equation 14](#)

$$I_{COUT(RMS)} = \frac{1}{\sqrt{12}} \times \left( \frac{V_{OUT} \times (V_{IN(MAX)} - V_{OUT})}{V_{IN(MAX)} \times L_{OUT} \times F_{SW} \times N_C} \right) \quad (14)$$

The calculated total RMS ripple current is 216 mA and the maximum total ESR required is 43 m $\Omega$ . These output capacitors exceed the requirements by a wide margin and will result in a reliable, high-performance design. The selected output capacitor must be rated for a voltage greater than the desired output voltage plus = the ripple voltage. Any derating amount must also be included.

Other capacitor types work well with the TPS54233-Q1, depending on the needs of the application.

## COMPENSATION COMPONENTS

The external compensation used with the TPS54233-Q1 allows for a wide range of output filter configurations. A large range of capacitor values and types of dielectric are supported. The design example uses ceramic X5R dielectric output capacitors, but other types are supported.

A Type II compensation scheme is recommended for the TPS54233-Q1. The compensation components are chosen to set the desired closed loop cross over frequency and phase margin for output filter components. The type II compensation has the following characteristics; a dc gain component, a low frequency pole, and a mid frequency zero / pole pair.

The dc gain is determined by [Equation 15](#):

$$G_{DC} = \frac{V_{ggm} \times V_{REF}}{V_O} \quad (15)$$

Where:

$$\begin{aligned} V_{ggm} &= 800 \\ V_{REF} &= 0.8 \text{ V} \end{aligned}$$

The low-frequency pole is determined by [Equation 16](#):

$$F_{PO} = 1/(2 \times \pi \times R_{OO} \times C_Z) \quad (16)$$

The mid-frequency zero is determined by [Equation 17](#):

$$F_{Z1} = 1/(2 \times \pi \times R_Z \times C_Z) \quad (17)$$

And, the mid-frequency pole is given by [Equation 18](#):

$$F_{P1} = 1/(2 \times \pi \times R_Z \times C_P) \quad (18)$$

The first step is to choose the closed loop crossover frequency. In general, the closed-loop crossover frequency should be less than 1/8 of the minimum operating frequency, but for the TPS54233-Q1 it is recommended that the maximum closed loop crossover frequency be not greater than 25 kHz. Next, the required gain and phase boost of the crossover network needs to be calculated. By definition, the gain of the compensation network must be the inverse of the gain of the modulator and output filter. For this design example, where the ESR zero is less than the closed loop crossover frequency, the gain of the modulator and output filter can be approximated by [Equation 19](#):

$$\text{Gain} = 20 \log \left( \frac{R_O}{R_{SENSE}} \right) - 20 \log \left( \frac{R_O}{R_{ESR}} \right) \quad (19)$$

Where:

$$\begin{aligned} R_{SENSE} &= 1\Omega/9 \\ R_O &= V_O/I_O \\ R_{ESR} &= \text{Equivalent series resistance of the output capacitor} \end{aligned}$$

The phase loss is given by [Equation 20](#):

$$PL = a \tan(2 \times \pi \times F_{CO} \times R_{ESR} \times C_O) - a \tan(2 \times \pi \times F_{CO} \times R_O \times C_O) \quad (20)$$

Where:

$$\begin{aligned} R_{ESR} &= \text{Equivalent series resistance of the output capacitor} \\ R_O &= V_O/I_O \end{aligned}$$

Now that the phase loss is known the required amount of phase boost to meet the phase margin requirement can be determined. The required phase boost is given by [Equation 21](#):

$$PB = (PM - 90 \text{ deg}) - PL \quad (21)$$

Where PM = the desired phase margin.

A zero / pole pair of the compensation network will be placed symmetrically around the intended closed loop frequency to provide maximum phase boost at the crossover point. The amount of separation can be determined by [Equation 22](#) and the resultant zero and pole frequencies are given by [Equation 23](#) and [Equation 24](#)

$$k = \tan \left( \frac{PB}{2} + 45 \text{ deg} \right) \quad (22)$$

$$F_{Z1} = \frac{F_{CO}}{k} \quad (23)$$

$$F_{P1} = F_{CO} \times k \quad (24)$$

The low-frequency pole is set so that the gain at the crossover frequency is equal to the inverse of the gain of the modulator and output filter. Due to the relationships established by the pole and zero relationships, the value of  $R_Z$  can be derived directly by [Equation 25](#) :

$$R_Z = \frac{V_O \times R_{OA} \times 0.98}{GM_{COMP} \times V_{ggm} \times V_{REF} \times R_{ESR}} \quad (25)$$

Where:

$V_O$  = Output voltage

$R_{OA}$  = 8.696 M $\Omega$

$GM_{COMP}$  = 9 A/V

$V_{ggm}$  = 800

$V_{REF}$  = 0.8 V

$R_{ESR}$  = Equivalent series resistance of the output capacitor

With  $R_Z$  known,  $C_Z$  and  $C_P$  can be calculated using [Equation 26](#) and [Equation 27](#):

$$C_Z = \frac{1}{2 \times \pi \times F_{Z1} \times R_z} \quad (26)$$

$$C_P = \frac{1}{2 \times \pi \times F_{P1} \times R_z} \quad (27)$$

For this design, a single 470  $\mu$ F output capacitor is used. The ESR is approximately .160  $\Omega$ . The desired closed loop crossover frequency is 22000 Hz.

Using [Equation 19](#) and [Equation 20](#), the output stage gain and phase loss are equivalent as:

Gain = -3.114 dB

and

PL = -4.96 degrees

For 60 degrees of phase margin, [Equation 21](#) requires no additional phase boost, so K can be set equal to 1.

[Equation 22](#), [Equation 23](#), and [Equation 24](#) are used to find the zero and pole frequencies of:

$F_{Z1}$  = 22000 Hz

And

$F_{P1}$  = 22000 Hz

$R_Z$ ,  $C_Z$ , and  $C_P$  are calculated using [Equation 25](#), [Equation 26](#), and [Equation 27](#):

$$R_Z = \frac{2.5 \times 8.696 \times 10^6 \times 0.98}{9 \times 800 \times 0.8 \times 0.160} = 30.5 \text{ k}\Omega \quad (28)$$

$$C_Z = \frac{1}{2 \times \pi \times 22000 \times 30500} = 237 \text{ pF} \quad (29)$$

$$C_P = \frac{1}{2 \times \pi \times 22000 \times 30500} = 237 \text{ pF} \quad (30)$$

Using standard values for R3, C6, and C7 in the application schematic of [Figure 12](#):

R3 = 30.9 k $\Omega$

C6 = 220 pF

C7 = 220 pF

The measured overall loop response for the circuit is given in [Figure 12](#). Note that the actual closed loop crossover frequency is higher than intended at about 25 kHz. This is primarily due to variation in the actual values of the output filter components and tolerance variation of the internal feed-forward gain circuitry. Overall the design has greater than 60 degrees of phase margin and will be completely stable over all combinations of line and load variability.

## BOOTSTRAP CAPACITOR

Every TPS54233-Q1 design requires a bootstrap capacitor, C4. The bootstrap capacitor must be 0.1 μF. The bootstrap capacitor is located between the PH pins and BOOT pin. The bootstrap capacitor should be a high-quality ceramic type with X7R or X5R grade dielectric for temperature stability.

## CATCH DIODE

The TPS54233-Q1 is designed to operate using an external catch diode between PH and GND. The selected diode must meet the absolute maximum ratings for the application: Reverse voltage must be higher than the maximum voltage at the PH pin, which is  $V_{INMAX} + 0.5$  V. Peak current must be greater than  $I_{OUTMAX}$  plus on half the peak to peak inductor current. Forward voltage drop should be small for higher efficiencies. It is important to note that the catch diode conduction time is typically longer than the high-side FET on time, so attention paid to diode parameters can make a marked improvement in overall efficiency. Additionally, check that the device chosen is capable of dissipating the power losses. For this design, a Diodes, Inc. B340A is chosen, with a reverse voltage of 40 V, forward current of 3 A, and a forward voltage drop of 0.5 V.

## OUTPUT VOLTAGE LIMITATIONS

Due to the internal design of the TPS54233-Q1, there are both upper and lower output voltage limits for any given input voltage. The upper limit of the output voltage set point is constrained by the maximum duty cycle of 91% and is given by [Equation 31](#):

$$V_{Omax} = 0.91 \times \left( (V_{INmin} - I_{Omax} \times R_{DS(on)max}) + V_D \right) - (I_{Omax} \times R_L) - V_D \quad (31)$$

Where:

- $V_{INmin}$  = Minimum input voltage
- $I_{Omax}$  = Maximum load current
- $V_D$  = Catch diode forward voltage
- $R_L$  = Output inductor series resistance

The equation assumes maximum on resistance for the internal high-side FET.

The lower limit is constrained by the minimum controllable on time which may be as high as 160 ns. The approximate minimum output voltage for a given input voltage and minimum load current is given by [Equation 32](#):

$$V_{Omin} = 0.051 \times \left( (V_{INmax} - I_{Omin} \times R_{in}) + V_D \right) - (I_{Omin} \times R_L) - V_D \quad (32)$$

Where:

- $V_{INmax}$  = Maximum input voltage
- $I_{Omin}$  = Minimum load current
- $V_D$  = Catch diode forward voltage
- $R_L$  = Output inductor series resistance

This equation assumes nominal on-resistance for the high-side FET and accounts for worst case variation of operating frequency set point. Any design operating near the operational limits of the device should be carefully checked to assure proper functionality.

## POWER DISSIPATION ESTIMATE

The following formulas show how to estimate the device power dissipation under continuous conduction mode operations. They should not be used if the device is working in the discontinuous conduction mode (DCM) or pulse skipping Eco-mode™.

The device power dissipation includes:

- 1) Conduction loss:  $P_{con} = I_{out}^2 \times R_{DS(on)} \times V_{OUT}/V_{IN}$
- 2) Switching loss:  $P_{sw} = 0.5 \times 10^{-9} \times V_{IN}^2 \times I_{OUT} \times F_{sw}$
- 3) Gate charge loss:  $P_{gc} = 22.8 \times 10^{-9} \times F_{sw}$
- 4) Quiescent current loss:  $P_q = 0.075 \times 10^{-3} \times V_{IN}$

Where:

$I_{OUT}$  is the output current (A).

$R_{DS(on)}$  is the on-resistance of the high-side MOSFET ( $\Omega$ ).

$V_{OUT}$  is the output voltage (V).

$V_{IN}$  is the input voltage (V).

$F_{sw}$  is the switching frequency (Hz).

So

$$P_{tot} = P_{con} + P_{sw} + P_{gc} + P_q$$

For given  $T_A$ ,  $T_J = T_A + R_{th} \times P_{tot}$ .

For given  $T_{JMAX} = 150^\circ\text{C}$ ,  $T_{AMAX} = T_{JMAX} - R_{th} \times P_{tot}$ .

Where:

$P_{tot}$  is the total device power dissipation (W).

$T_A$  is the ambient temperature ( $^\circ\text{C}$ ).

$T_J$  is the junction temperature ( $^\circ\text{C}$ ).

$R_{th}$  is the thermal resistance of the package ( $^\circ\text{C}/\text{W}$ ).

$T_{JMAX}$  is maximum junction temperature ( $^\circ\text{C}$ ).

$T_{AMAX}$  is maximum ambient temperature ( $^\circ\text{C}$ ).

## PCB LAYOUT

The VIN pin should be bypassed to ground with a low ESR ceramic bypass capacitor. Care should be taken to minimize the loop area formed by the bypass capacitor connections, the VIN pin, and the anode of the catch diode. The typical recommended bypass capacitance is 10  $\mu\text{F}$  ceramic with a X5R or X7R dielectric and the optimum placement is closest to the VIN pins and the source of the anode of the catch diode. See [Figure 13](#) for a PCB layout example. The GND D pin should be tied to the PCB ground plane at the pin of the IC. The source of the low-side MOSFET should be connected directly to the top side PCB ground area used to tie together the ground sides of the input and output capacitors as well as the anode of the catch diode. The PH pin should be routed to the cathode of the catch diode and to the output inductor. Since the PH connection is the switching node, the catch diode and output inductor should be located very close to the PH pins, and the area of the PCB conductor minimized to prevent excessive capacitive coupling. For operation at full rated load, the top side ground area must provide adequate heat dissipating area. The TPS54233-Q1 uses a fused lead frame so that the GND pin acts as a conductive path for heat dissipation from the die. Many applications have larger areas of internal or back side ground plane available, and the top side ground area can be connected to these areas using multiple vias under or adjacent to the device to help dissipate heat. The additional external components can be placed approximately as shown. It may be possible to obtain acceptable performance with alternate layout schemes, however this layout has been shown to produce good results and is intended as a guideline.

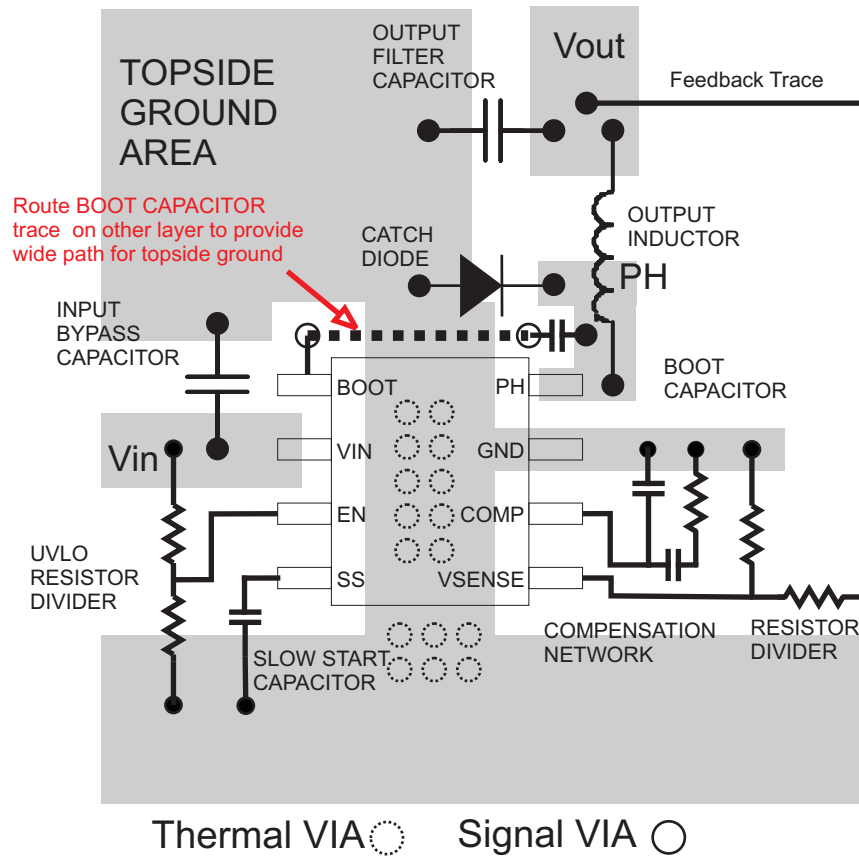

Figure 13. TPS54233-Q1 Board Layout

**Estimated Circuit Area**

The estimated printed circuit board area for the components used in the design of Figure 12 is 0.72 in<sup>2</sup>. This area does not include test points or connectors.

**ELECTROMAGNETIC INTERFERENCE (EMI) CONSIDERATIONS**

As EMI becomes a rising concern in more and more applications, the internal design of the TPS54233-Q1 takes measures to reduce the EMI. The high-side MOSFET gate drive is designed to reduce the PH pin voltage ringing. The internal IC rails are isolated to decrease the noise sensitivity. A package bond wire scheme is used to lower the parasitics effects.

To achieve the best EMI performance, external component selection and board layout are equally important. Follow the *Step by Step Design Procedure* above to prevent potential EMI issues.

APPLICATION CURVES

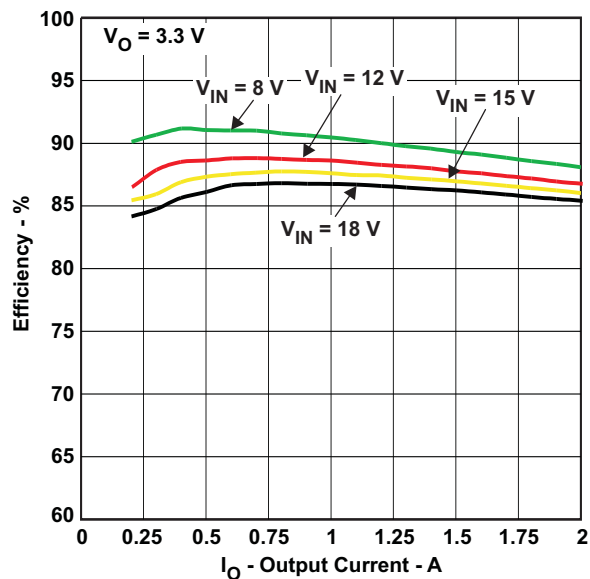

Figure 14. TPS54233-Q1 Efficiency

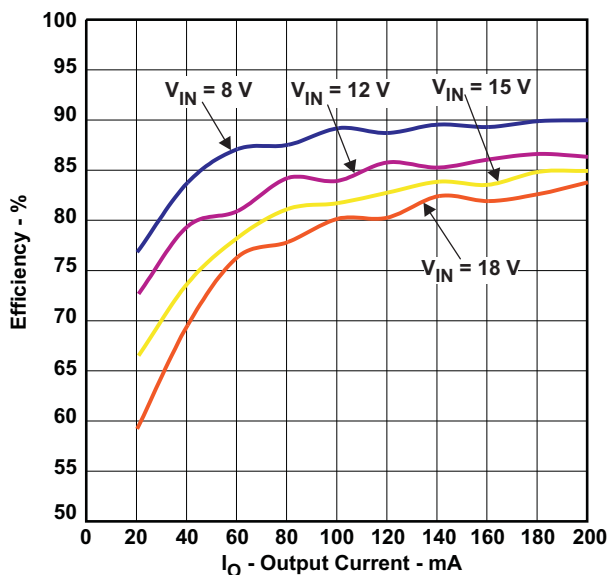

Figure 15. TPS54233-Q1 Low Current Efficiency

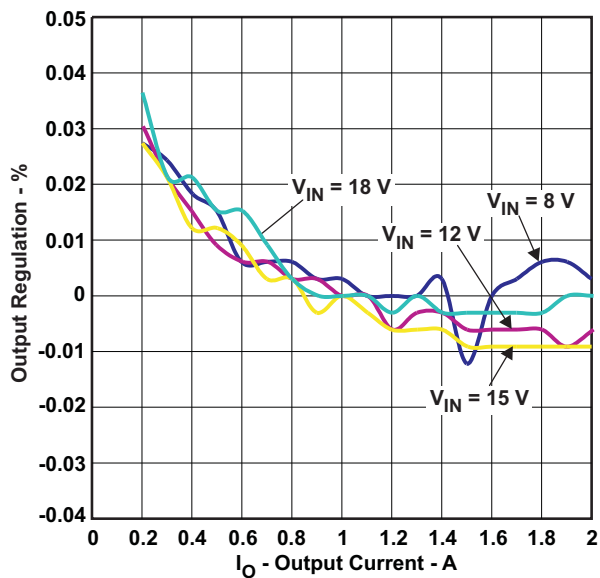

Figure 16. TPS54233-Q1 Load Regulation

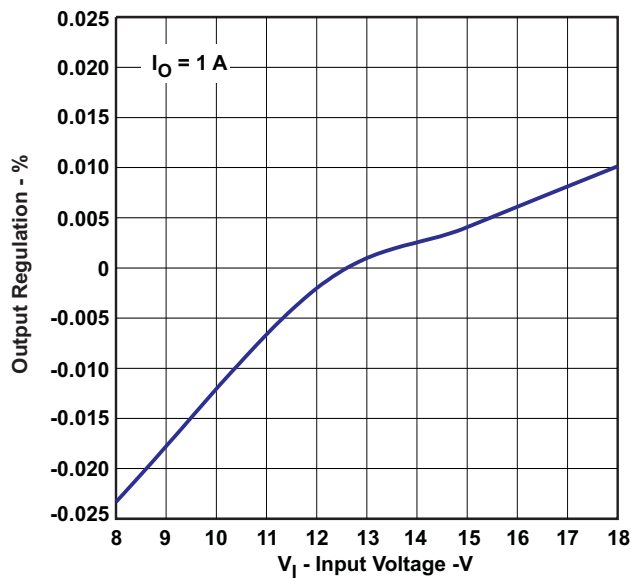

Figure 17. TPS54233-Q1 Line Regulation

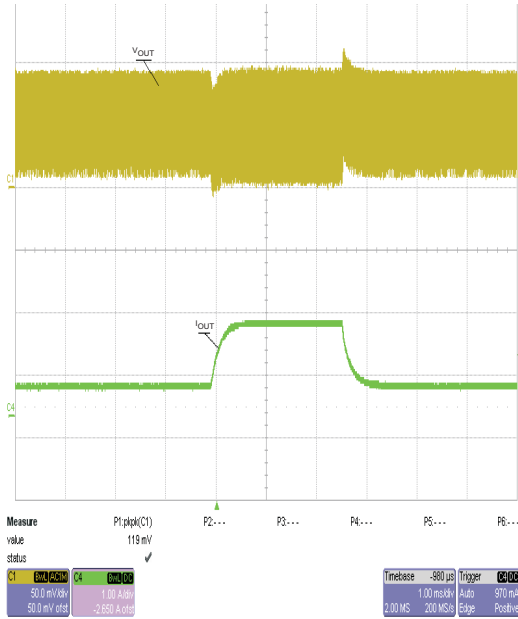

Figure 18. TPS54233-Q1 Transient Response

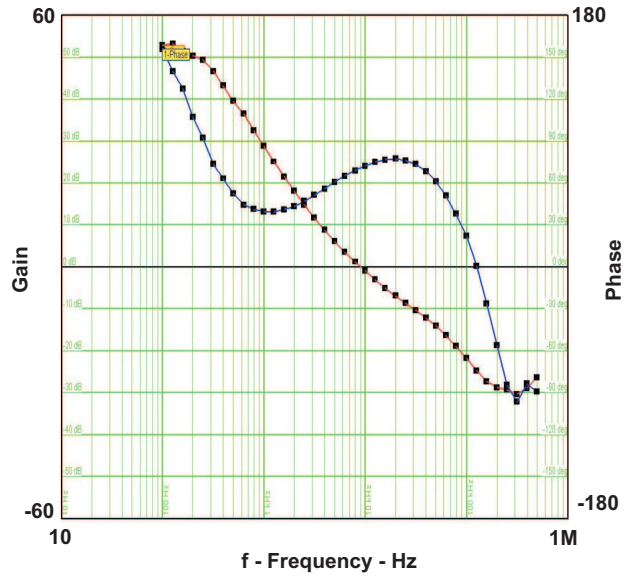

Figure 19. TPS54233-Q1 Loop Response

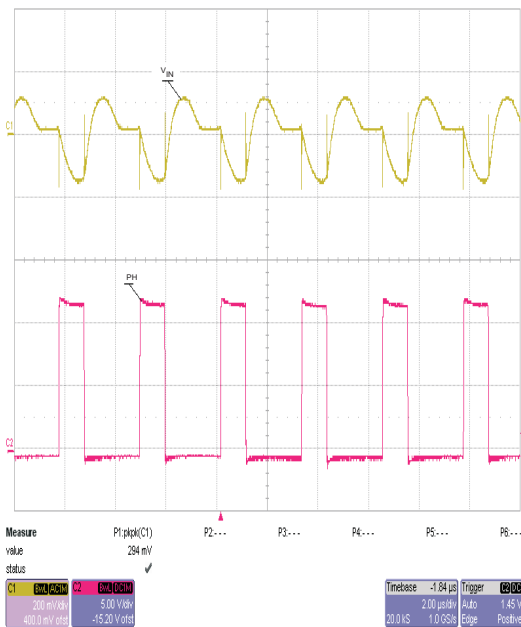

Figure 20. TPS54233-Q1 Input Ripple

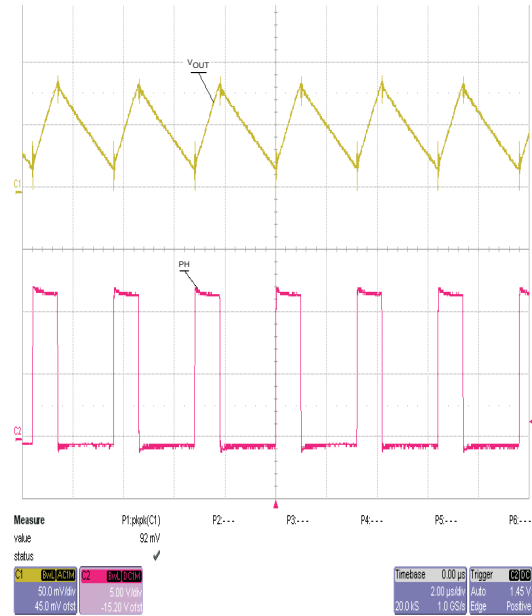

Figure 21. TPS54233-Q1 Output Ripple

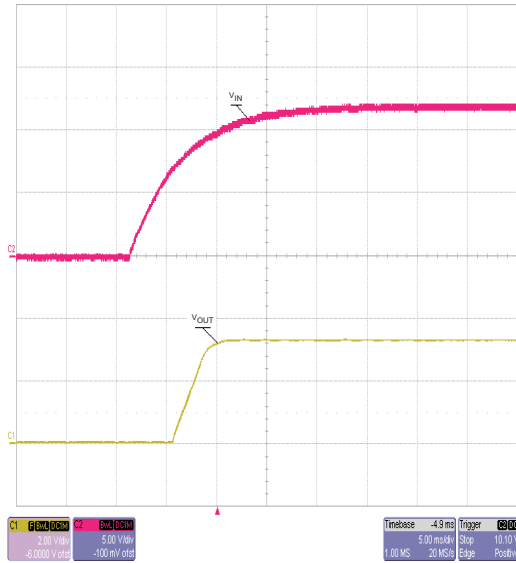

Figure 22. TPS54233-Q1 Start Up

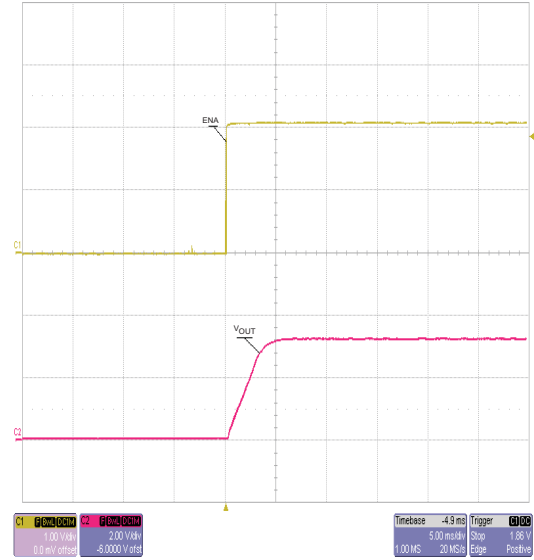

Figure 23. TPS54233-Q1 Start-up Relative to Enable

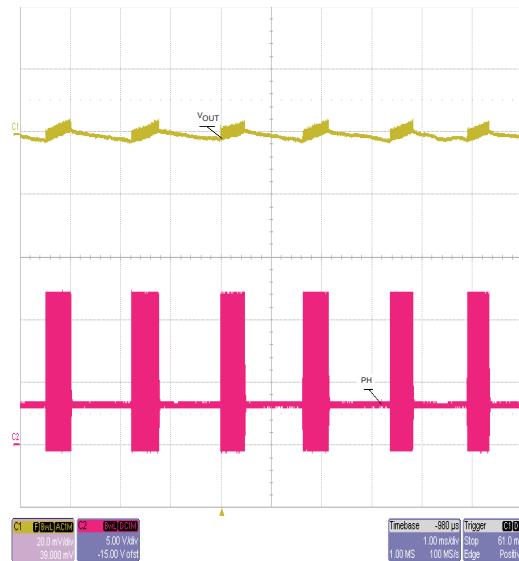

Figure 24. TPS54233-Q1 Eco-mode™ Operation

**PACKAGING INFORMATION**

Orderable Device	Status (1)	Package Type	Package Drawing	Pins	Package Qty	Eco Plan (2)	Lead/Ball Finish (6)	MSL Peak Temp (3)	Op Temp (°C)	Device Marking (4/5)	Samples
TPS54233QDRQ1	ACTIVE	SOIC	D	8	2500	Green (RoHS & no Sb/Br)	CU NIPDAU	Level-1-260C-UNLIM	-40 to 125	54233Q	<b>Samples</b>

(1) The marketing status values are defined as follows:

**ACTIVE:** Product device recommended for new designs.

**LIFEBUY:** TI has announced that the device will be discontinued, and a lifetime-buy period is in effect.

**NRND:** Not recommended for new designs. Device is in production to support existing customers, but TI does not recommend using this part in a new design.

**PREVIEW:** Device has been announced but is not in production. Samples may or may not be available.

**OBSELETE:** TI has discontinued the production of the device.

(2) Eco Plan - The planned eco-friendly classification: Pb-Free (RoHS), Pb-Free (RoHS Exempt), or Green (RoHS & no Sb/Br) - please check <http://www.ti.com/productcontent> for the latest availability information and additional product content details.

**TBD:** The Pb-Free/Green conversion plan has not been defined.

**Pb-Free (RoHS):** TI's terms "Lead-Free" or "Pb-Free" mean semiconductor products that are compatible with the current RoHS requirements for all 6 substances, including the requirement that lead not exceed 0.1% by weight in homogeneous materials. Where designed to be soldered at high temperatures, TI Pb-Free products are suitable for use in specified lead-free processes.

**Pb-Free (RoHS Exempt):** This component has a RoHS exemption for either 1) lead-based flip-chip solder bumps used between the die and package, or 2) lead-based die adhesive used between the die and leadframe. The component is otherwise considered Pb-Free (RoHS compatible) as defined above.

**Green (RoHS & no Sb/Br):** TI defines "Green" to mean Pb-Free (RoHS compatible), and free of Bromine (Br) and Antimony (Sb) based flame retardants (Br or Sb do not exceed 0.1% by weight in homogeneous material)

(3) MSL, Peak Temp. - The Moisture Sensitivity Level rating according to the JEDEC industry standard classifications, and peak solder temperature.

(4) There may be additional marking, which relates to the logo, the lot trace code information, or the environmental category on the device.

(5) Multiple Device Markings will be inside parentheses. Only one Device Marking contained in parentheses and separated by a "-" will appear on a device. If a line is indented then it is a continuation of the previous line and the two combined represent the entire Device Marking for that device.

(6) Lead/Ball Finish - Orderable Devices may have multiple material finish options. Finish options are separated by a vertical ruled line. Lead/Ball Finish values may wrap to two lines if the finish value exceeds the maximum column width.

**Important Information and Disclaimer:** The information provided on this page represents TI's knowledge and belief as of the date that it is provided. TI bases its knowledge and belief on information provided by third parties, and makes no representation or warranty as to the accuracy of such information. Efforts are underway to better integrate information from third parties. TI has taken and continues to take reasonable steps to provide representative and accurate information but may not have conducted destructive testing or chemical analysis on incoming materials and chemicals. TI and TI suppliers consider certain information to be proprietary, and thus CAS numbers and other limited information may not be available for release.

In no event shall TI's liability arising out of such information exceed the total purchase price of the TI part(s) at issue in this document sold by TI to Customer on an annual basis.

**OTHER QUALIFIED VERSIONS OF TPS54233-Q1 :**

- Catalog: [TPS54233](#)

## NOTE: Qualified Version Definitions:

- Catalog - TI's standard catalog product

**TAPE AND REEL INFORMATION**

**QUADRANT ASSIGNMENTS FOR PIN 1 ORIENTATION IN TAPE**

\*All dimensions are nominal

Device	Package Type	Package Drawing	Pins	SPQ	Reel Diameter (mm)	Reel Width W1 (mm)	A0 (mm)	B0 (mm)	K0 (mm)	P1 (mm)	W (mm)	Pin1 Quadrant
TPS54233QDRQ1	SOIC	D	8	2500	330.0	12.4	6.4	5.2	2.1	8.0	12.0	Q1

**TAPE AND REEL BOX DIMENSIONS**

\*All dimensions are nominal

Device	Package Type	Package Drawing	Pins	SPQ	Length (mm)	Width (mm)	Height (mm)
TPS54233QDRQ1	SOIC	D	8	2500	367.0	367.0	35.0



# EXAMPLE BOARD LAYOUT

D0008A

SOIC - 1.75 mm max height

SMALL OUTLINE INTEGRATED CIRCUIT



LAND PATTERN EXAMPLE  
 EXPOSED METAL SHOWN  
 SCALE:8X



SOLDER MASK DETAILS

4214825/C 02/2019

NOTES: (continued)

- 6. Publication IPC-7351 may have alternate designs.
- 7. Solder mask tolerances between and around signal pads can vary based on board fabrication site.

# EXAMPLE STENCIL DESIGN

D0008A

SOIC - 1.75 mm max height

SMALL OUTLINE INTEGRATED CIRCUIT



SOLDER PASTE EXAMPLE  
BASED ON .005 INCH [0.125 MM] THICK STENCIL  
SCALE:8X

4214825/C 02/2019

NOTES: (continued)

8. Laser cutting apertures with trapezoidal walls and rounded corners may offer better paste release. IPC-7525 may have alternate design recommendations.
9. Board assembly site may have different recommendations for stencil design.

## IMPORTANT NOTICE AND DISCLAIMER

TI PROVIDES TECHNICAL AND RELIABILITY DATA (INCLUDING DATASHEETS), DESIGN RESOURCES (INCLUDING REFERENCE DESIGNS), APPLICATION OR OTHER DESIGN ADVICE, WEB TOOLS, SAFETY INFORMATION, AND OTHER RESOURCES "AS IS" AND WITH ALL FAULTS, AND DISCLAIMS ALL WARRANTIES, EXPRESS AND IMPLIED, INCLUDING WITHOUT LIMITATION ANY IMPLIED WARRANTIES OF MERCHANTABILITY, FITNESS FOR A PARTICULAR PURPOSE OR NON-INFRINGEMENT OF THIRD PARTY INTELLECTUAL PROPERTY RIGHTS.

These resources are intended for skilled developers designing with TI products. You are solely responsible for (1) selecting the appropriate TI products for your application, (2) designing, validating and testing your application, and (3) ensuring your application meets applicable standards, and any other safety, security, or other requirements. These resources are subject to change without notice. TI grants you permission to use these resources only for development of an application that uses the TI products described in the resource. Other reproduction and display of these resources is prohibited. No license is granted to any other TI intellectual property right or to any third party intellectual property right. TI disclaims responsibility for, and you will fully indemnify TI and its representatives against, any claims, damages, costs, losses, and liabilities arising out of your use of these resources.

TI's products are provided subject to TI's Terms of Sale ([www.ti.com/legal/termsofsale.html](http://www.ti.com/legal/termsofsale.html)) or other applicable terms available either on [ti.com](http://ti.com) or provided in conjunction with such TI products. TI's provision of these resources does not expand or otherwise alter TI's applicable warranties or warranty disclaimers for TI products.

Mailing Address: Texas Instruments, Post Office Box 655303, Dallas, Texas 75265  
Copyright © 2019, Texas Instruments Incorporated

## Looking for pricing, stock, or lifecycle information?

Click below to explore more details on WIN SOURCE:

 [View TPS54233QDRQ1](#) on WIN SOURCE

 [Texas Instruments](#) Information

## Optimize Your Supply Chain with WIN SOURCE Solutions

-  Global Sourcing Solution
-  Obsolete Management
-  Cost Control Management
-  Shortage Management
-  Alternative Solution
-  Excess Inventory Management