



**THE DATASHEET OF  
UCC2895QDWRQ1**



## BiCMOS ADVANCED PHASE-SHIFT PWM CONTROLLER

Check for Samples: [UCC2895-Q1](#)

### FEATURES

- Qualified for Automotive Applications
- Programmable Output Turn-On Delay
- Bidirectional Oscillator Synchronization
- Voltage-Mode, Peak-Current-Mode, or Average-Current-Mode Control
- Programmable Soft Start/Soft Stop and Chip Disable Via a Single Pin
- 0% to 100% Duty-Cycle Control
- 7-MHz Error Amplifier
- Operation to 1 MHz
- Typical 5-mA Operating Current at 500 kHz
- Very Low 150- $\mu$ A Current During Undervoltage Lockout (UVLO)

### APPLICATIONS

- Phase-Shifted Full-Bridge Converters
- Off-Line, Telecom, Datacom, and Servers
- Distributed Power Architecture
- High-Density Power Modules

### DESCRIPTION

The UCC2895-Q1 is a phase-shift pulse-width modulation (PWM) controller that implements control of a full-bridge power stage by phase shifting the switching of one half-bridge with respect to the other. It allows constant-frequency PWM in conjunction with resonant zero-voltage switching to provide high efficiency at high frequencies. The device can be used either as a voltage-mode or current-mode controller.

Although the UCC2895-Q1 maintains the functionality of the UC3875/6/7/8 family and UC3879, it improves on that controller family with additional features such as enhanced control logic, adaptive delay set, and shutdown capability. Because it is built using the BCDMOS process, it operates with dramatically less supply current than its bipolar counterparts. The UCC2895-Q1 can operate with a maximum clock frequency of 1 MHz.

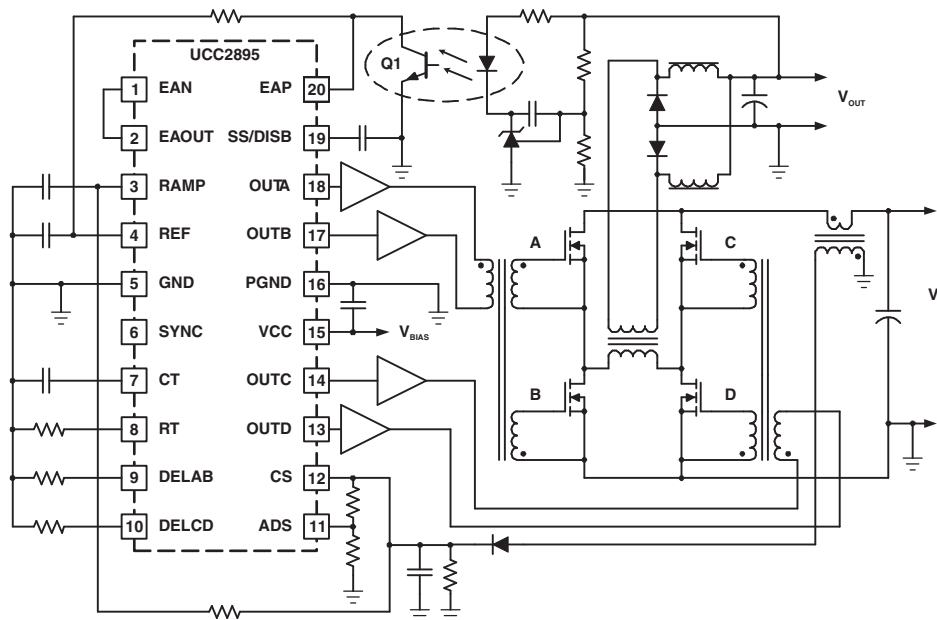

Please be aware that an important notice concerning availability, standard warranty, and use in critical applications of Texas Instruments semiconductor products and disclaimers thereto appears at the end of this data sheet.

**ORDERING INFORMATION<sup>(1)</sup>**

T <sub>A</sub>	PACKAGE <sup>(2)</sup>		ORDERABLE PART NUMBER	TOP-SIDE MARKING
-40°C to 125°C	SOIC – DW	Reel of 2000	UCC2895QDWRQ1	UCC2895Q

- (1) For the most-current package and ordering information, see the Package Option Addendum at the end of this document, or see the TI Web site at [www.ti.com](http://www.ti.com).
- (2) Package drawings, thermal data, and symbolization are available at [www.ti.com/packaging](http://www.ti.com/packaging).

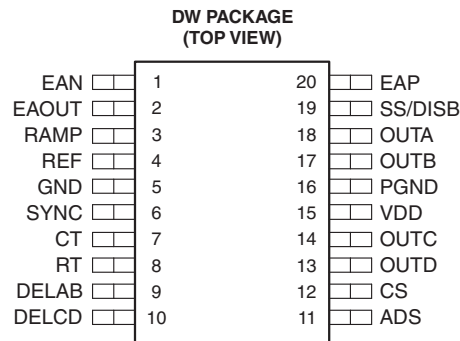

**ABSOLUTE MAXIMUM RATINGS<sup>(1)</sup>**

T<sub>A</sub> = -40°C to 125°C, all voltage values are with respect to the network ground terminal (unless otherwise noted)

			VALUE
V <sub>DD</sub>	Supply voltage	I <sub>DD</sub> < 10 mA	17 V
I <sub>DD</sub>	Supply current		30 mA
I <sub>REF</sub>	Reference current		15 mA
I <sub>O</sub>	Output current		100 mA
	Analog input voltage range	EAP, EAN, EAOUT, RAMP, SYNC, ADS, CS, SS/DISB	-0.3 V to REF + 0.3 V
	Drive output voltage range	OUTA, OUTB, OUTC, OUTD	-0.3 V to VDD + 0.3 V
P <sub>D</sub>	Power dissipation	T <sub>A</sub> = 25°C	650 mW
T <sub>stg</sub>	Storage temperature range		-65°C to 150°C
T <sub>J</sub>	Junction temperature range		-55°C to 150°C
ESD	Electrostatic discharge protection	Human-body model (HBM)	800 V
		Machine model (MM)	200 V
		Charged-device model (CDM)	2000 V

- (1) Stresses beyond those listed under *Absolute Maximum Ratings* may cause permanent damage to the device. These are stress ratings only, and functional operation of the device at these or any other conditions beyond those indicated under *Recommended Operating Conditions* is not implied. Exposure to absolute-maximum-rated conditions for extended periods may affect device reliability.

**RECOMMENDED OPERATING CONDITIONS<sup>(1)</sup>**

			MIN	NOM	MAX	UNIT
V <sub>DD</sub>	Supply voltage		10		16.5	V
C <sub>VDD</sub>	Supply voltage bypass capacitor <sup>(2)</sup>			10 × C <sub>REF</sub>		μF
C <sub>REF</sub>	Reference bypass capacitor <sup>(3)</sup>		0.1		4.7	μF
C <sub>T</sub>	Timing capacitor	For 500-kHz switching frequency		220		pF
R <sub>T</sub>	Timing resistor	For 500-kHz switching frequency		82		kΩ

- (1) It is recommended that there be a single point grounded between GND and PGND directly under the device. There should be a separate ground plane associated with the GND pin and all components associated with pins 1 through 12 plus 19 and 20 should be located over this ground plane. Any connections associated with these pins to ground should be connected to this ground plane.
- (2) The V<sub>DD</sub> capacitor should be a low-ESR, -ESL ceramic capacitor located directly across the VDD and PGND pins. A larger bulk capacitor should be located as physically close as possible to the V<sub>DD</sub> pins.
- (3) The V<sub>REF</sub> capacitor should be a low-ESR, -ESL ceramic capacitor located directly across the REF and GND pins. If a larger capacitor is desired for V<sub>REF</sub>, then it should be located near the V<sub>REF</sub> capacitor and connected to the V<sub>REF</sub> pin with a resistor of 51 Ω or greater. The bulk capacitor on VDD must be a factor of 10 greater than the total V<sub>REF</sub> capacitance.

**RECOMMENDED OPERATING CONDITIONS<sup>(1)</sup> (continued)**

	MIN	NOM	MAX	UNIT
R <sub>DEL_AB</sub> R <sub>DEL_CD</sub> Delay resistor	2.5		40	kΩ
T <sub>J</sub> Operating junction temperature <sup>(4)</sup>	-55		125	°C

(4) It is not recommended that the device operate under conditions beyond those specified in this table for extended periods of time.

**ELECTRICAL CHARACTERISTICS**

V<sub>DD</sub> = 12 V, R<sub>T</sub> = 82 kΩ, C<sub>T</sub> = 220 pF, R<sub>DELAB</sub> = 10 kΩ, R<sub>DELCD</sub> = 10 kΩ, C<sub>REF</sub> = 0.1 μF, C<sub>VDD</sub> = 0.1 μF, no load on the outputs, T<sub>A</sub> = T<sub>J</sub> = -40°C to 125°C (unless otherwise noted)

PARAMETER	TEST CONDITIONS	MIN	TYP	MAX	UNIT
<b>Undervoltage Lockout (UVLO)</b>					
UVLO <sub>(on)</sub> Start-up voltage threshold		10.2	11	11.8	V
UVLO <sub>(off)</sub> Minimum operating voltage after start-up		8.2	9	9.8	V
UVLO <sub>(hys)</sub> Hysteresis		1	2	3	V
<b>Supply</b>					
I <sub>START</sub> Start-up current	V <sub>DD</sub> = 8 V		150	250	μA
I <sub>DD</sub> Operating current			5	6	mA
V <sub>DD_CLAMP</sub> VDD clamp voltage	I <sub>DD</sub> = 10 mA	16.5	17.5	18.5	V
<b>Voltage Reference</b>					
V <sub>REF</sub> Output voltage	T <sub>J</sub> = 25°C	4.94	5	5.06	V
	10 V < V <sub>DD</sub> < V <sub>DD_CLAMP</sub> , 0 mA < I <sub>REF</sub> < 5 mA, T <sub>J</sub> = -40°C to 125°C	4.85	5	5.15	
I <sub>SC</sub> Short-circuit current	REF = 0 V, T <sub>J</sub> = 25°C	10	20		mA
<b>Error Amplifier</b>					
	Common-mode input voltage	-0.1		3.6	V
V <sub>IO</sub> Offset voltage		-7		7	mV
I <sub>BIAS</sub> Input bias current (EAP, EAN)		-1		1	μA
V <sub>OH_EAOUT</sub> High-level output voltage	EAP – EAN = 500 mV, I <sub>EAOUT</sub> = -0.5 mA	4	4.5	5	V
V <sub>OL_EAOUT</sub> Low-level output voltage	EAP – EAN = -500 mV, I <sub>EAOUT</sub> = 0.5 mA	0	0.2	0.4	V
I <sub>SOURCE</sub> Error amplifier output source current	EAP – EAN = 500 mV, EAOUT = 2.5 V	1	1.5		mA
I <sub>SINK</sub> Error amplifier output sink current	EAP – EAN = -500 mV, EAOUT = 2.5 V	2.5	4.5		mA
A <sub>VOL</sub> Open-loop dc gain		75	85		dB
GBW Unity gain bandwidth <sup>(1)</sup>		5	7		MHz
	Slew rate <sup>(1)</sup>	1.5	2.2		V/μs
	No-load comparator turn-off threshold	0.45	0.5	0.55	V
	No-load comparator turn-on threshold	0.55	0.6	0.69	V
	No-load comparator hysteresis	0.035	0.1	0.165	V
<b>Oscillator</b>					
f <sub>OSC</sub> Frequency	T <sub>J</sub> = 25°C	473	500	527	kHz
	Frequency total variation <sup>(1)</sup>		2.5%	5%	
V <sub>IH_SYNC</sub> High-level input voltage, SYNC		2.05	2.1	2.4	V
V <sub>OH_SYNC</sub> High-level input voltage, SYNC	I <sub>SYNC</sub> = -400 μA, V <sub>CT</sub> = 2.6 V	4.1	4.5	5	V
V <sub>OL_SYNC</sub> Low-level output voltage, SYNC	I <sub>SYNC</sub> = 100 μA, V <sub>CT</sub> = 2.6 V	0	0.5	1	V
	SYNC output pulse width		85	135	ns
V <sub>RT</sub> Timing resistor voltage		2.9	3	3.1	V
V <sub>CT(peak)</sub> Timing capacitor peak voltage		2.25	2.35	2.55	V
V <sub>CT(valley)</sub> Timing capacitor valley voltage		0	0.2	0.4	V

(1) Specified by design

**ELECTRICAL CHARACTERISTICS (continued)**

$V_{DD} = 12\text{ V}$ ,  $R_T = 82\text{ k}\Omega$ ,  $C_T = 220\text{ pF}$ ,  $R_{DELAB} = 10\text{ k}\Omega$ ,  $R_{DELCD} = 10\text{ k}\Omega$ ,  $C_{REF} = 0.1\text{ }\mu\text{F}$ ,  $C_{VDD} = 0.1\text{ }\mu\text{F}$ , no load on the outputs,  $T_A = T_J = -40^\circ\text{C}$  to  $125^\circ\text{C}$  (unless otherwise noted)

PARAMETER		TEST CONDITIONS	MIN	TYP	MAX	UNIT
<b>Current Sense</b>						
$I_{CS(bias)}$	Current sense bias current	$0\text{ V} < CS < 2.5\text{ V}$ , $0\text{ V ADS} < 2.5\text{ V}$	-4.5		20	$\mu\text{A}$
	Peak current threshold		1.9	2	2.1	V
	Overcurrent threshold		2.4	2.5	2.6	V
	Current sense to output delay	$0\text{ V} \leq CS \leq 2.3\text{ V}$ , $DELAB = DELCD = REF$		75	110	ns

**ELECTRICAL CHARACTERISTICS (continued)**

$V_{DD} = 12\text{ V}$ ,  $R_T = 82\text{ k}\Omega$ ,  $C_T = 220\text{ pF}$ ,  $R_{DELAB} = 10\text{ k}\Omega$ ,  $R_{DELCD} = 10\text{ k}\Omega$ ,  $C_{REF} = 0.1\text{ }\mu\text{F}$ ,  $C_{VDD} = 0.1\text{ }\mu\text{F}$ , no load on the outputs,  $T_A = T_J = -40^\circ\text{C}$  to  $125^\circ\text{C}$  (unless otherwise noted)

PARAMETER	TEST CONDITIONS	MIN	TYP	MAX	UNIT	
<b>Soft Start/Shutdown</b>						
$I_{SOURCE}$	Soft-start source current	SS/DISB = 3 V, CS = 1.9 V	-40	-35	-30	$\mu\text{A}$
$I_{SINK}$	Soft-start sink current	SS/DISB = 3 V, CS = 2.6 V	325	350	375	$\mu\text{A}$
	Soft-start/disable comparator threshold		0.44	0.5	0.56	V
<b>Adaptive Delay Set (ADS)</b>						
	DELAB/DELCD output voltage	ADS = CS = 0 V	0.45	0.5	0.55	V
		ADS = 0 V, CS = 2 V	1.9	2	2.1	
$t_{DELAY}$	Output delay <sup>(2)</sup> <sup>(3)</sup>	ADS = CS = 0 V	450	560	620	ns
	ADS bias current	0 V < ADS < 2.5 V, 0 V < CS < 2.5 V	-20		20	$\mu\text{A}$
<b>Output</b>						
$V_{OH}$	High-level output voltage (all outputs)	$I_{OUT} = -10\text{ mA}$ , VDD to output		250	420	mV
$V_{OL}$	Low-level output voltage (all outputs)	$I_{OUT} = 10\text{ mA}$		150	270	mV
$t_R$	Rise time <sup>(2)</sup>	$C_{LOAD} = 100\text{ pF}$		20	35	ns
$t_F$	Fall time <sup>(2)</sup>	$C_{LOAD} = 100\text{ pF}$		20	35	ns

(2) Specified by design

(3) Output delay is measured between OUTA and OUTB or between OUTC and OUTD. Output delay is defined as shown in the following figure, where:

$t_{f(OUTA)}$  = falling edge of OUTA signal

$t_{r(OUTB)}$  = rising edge of OUTB signal

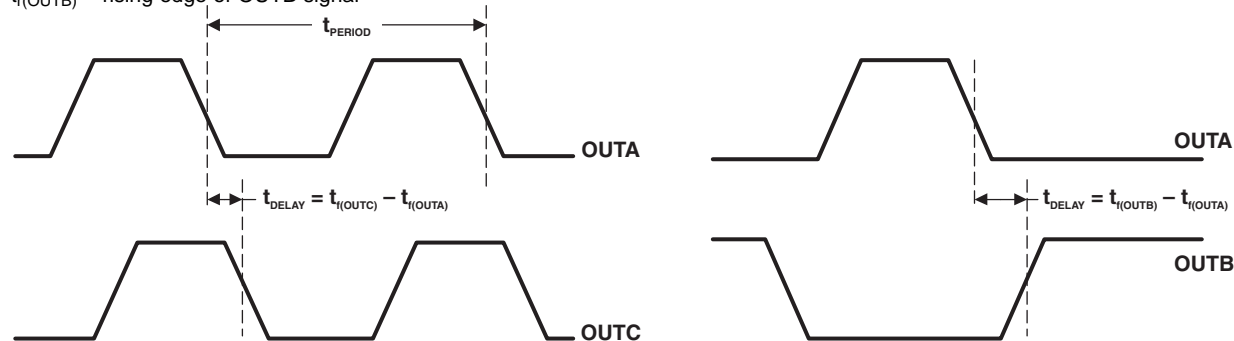

Same applies to OUTB and OUTD

Same applies to OUTC and OUTD

**ELECTRICAL CHARACTERISTICS (continued)**

$V_{DD} = 12\text{ V}$ ,  $R_T = 82\text{ k}\Omega$ ,  $C_T = 220\text{ pF}$ ,  $R_{DELAB} = 10\text{ k}\Omega$ ,  $R_{DELCD} = 10\text{ k}\Omega$ ,  $C_{REF} = 0.1\text{ }\mu\text{F}$ ,  $C_{VDD} = 0.1\text{ }\mu\text{F}$ , no load on the outputs,  $T_A = T_J = -40^\circ\text{C}$  to  $125^\circ\text{C}$  (unless otherwise noted)

PARAMETER	TEST CONDITIONS	MIN	TYP	MAX	UNIT
<b>PWM Comparator</b>					
EAOUT to RAMP input offset voltage	RAMP = 0 V, DELAB = DELCD = REF	0.7	0.85	1.05	V
Minimum phase shift <sup>(4)</sup> (OUTA to OUTC, OUTB to OUTD)	RAMP = 0 V, EAOUT = 650 mV	0	0.85%	1.5%	
$t_{DELAY}$ <sup>(5)</sup> (RAMP to OUTC, RAMP to OUTD)	$0\text{ V} < \text{RAMP} < 2.5\text{ V}$ , EAOUT = 1.2 V, DELAB = DELCD = REF		70	120	ns
$I_{R(bias)}$	RAMP bias current	-5		5	$\mu\text{A}$
$I_{R(sink)}$	RAMP sink current	11	19		mA

(4) Minimum phase shift is defined as:

$$\Phi = 180 \times \frac{t_{f(OUTC)} - t_{f(OUTA)}}{t_{PERIOD}} \quad \text{or} \quad \Phi = 180 \times \frac{t_{f(OUTC)} - t_{f(OUTB)}}{t_{PERIOD}}$$

where:

- $t_{f(OUTA)}$  = falling edge of OUTA signal
- $t_{f(OUTB)}$  = falling edge of OUTB signal
- $t_{f(OUTC)}$  = falling edge of OUTC signal
- $t_{f(OUTD)}$  = falling edge of OUTD signal
- $t_{PERIOD}$  = period of OUTA or OUTB signal

(5) Output delay is measured between OUTA and OUTB or between OUTC and OUTD. Output delay is defined as shown in the following figure, where:

- $t_{f(OUTA)}$  = falling edge of OUTA signal
- $t_{r(OUTB)}$  = rising edge of OUTB signal

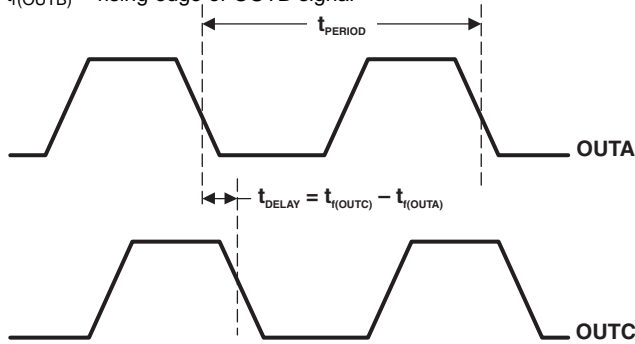

Same applies to OUTB and OUTD

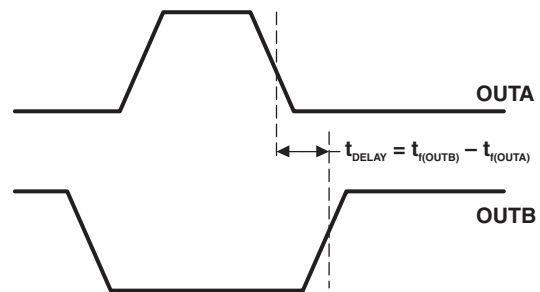

Same applies to OUTC and OUTD

**TERMINAL FUNCTIONS**

TERMINAL		I/O	DESCRIPTION
NAME	NO.		
ADS	11	I	Adaptive delay set. Sets the ratio between the maximum and minimum programmed output delay dead time.
CS	12	I	Current-sense input for cycle-by-cycle current limiting and for overcurrent comparator
CT	7	I	Oscillator timing capacitor for programming the switching frequency. The oscillator charges CT via a programmed current.
DELAB	9	I	Delay programming between complementary outputs. DELAB programs the dead time between switching of output A and output B.
DELCD	10	I	Delay programming between complementary outputs. DELCD programs the dead time between switching of output C and output D.
EAOUT	2	I/O	Error amplifier output
EAP	20	I	Noninverting input to the error amplifier. Keep below 3.6 V for proper operation.
EAN	1	I	Inverting input to the error amplifier. Keep below 3.6 V for proper operation.
GND	5	–	Ground for all circuits except the output stages
OUTA	18	O	The four outputs are 100-mA CMOS drivers and are optimized to drive FET driver circuits such as the UCC27424 or gate-drive transformers.
OUTB	17	O	
OUTC	14	O	
OUTD	13	O	
PGND	16	–	Output-stage power ground
RAMP	3	I	Inverting input of the PWM comparator
REF	4	O	5-V $\pm$ 1.2% 5-mA voltage reference. For best performance, bypass with a 0.1- $\mu$ F low-ESR low-ESL capacitor to ground. Do not use more than 1 $\mu$ F of total capacitance on this pin.
RT	8	I	Oscillator timing resistor for programming the switching frequency
SS/DISB	19	I	Soft start/disable. This pin combines two independent functions.
SYNC	6	I/O	Oscillator synchronization. This pin is bidirectional.
VDD	15	I	Power-supply input. VDD must be bypassed with a minimum of a 1- $\mu$ F low-ESR low-ESL capacitor to ground.

FUNCTIONAL BLOCK DIAGRAM

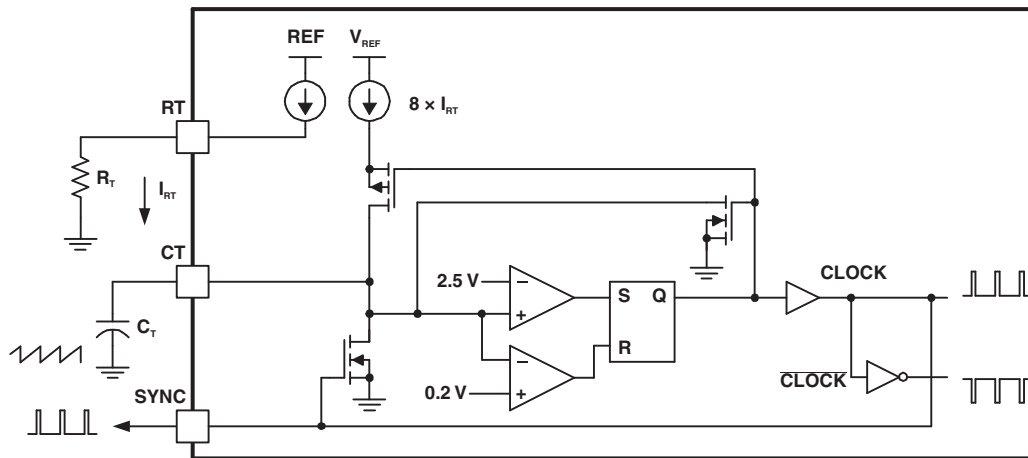
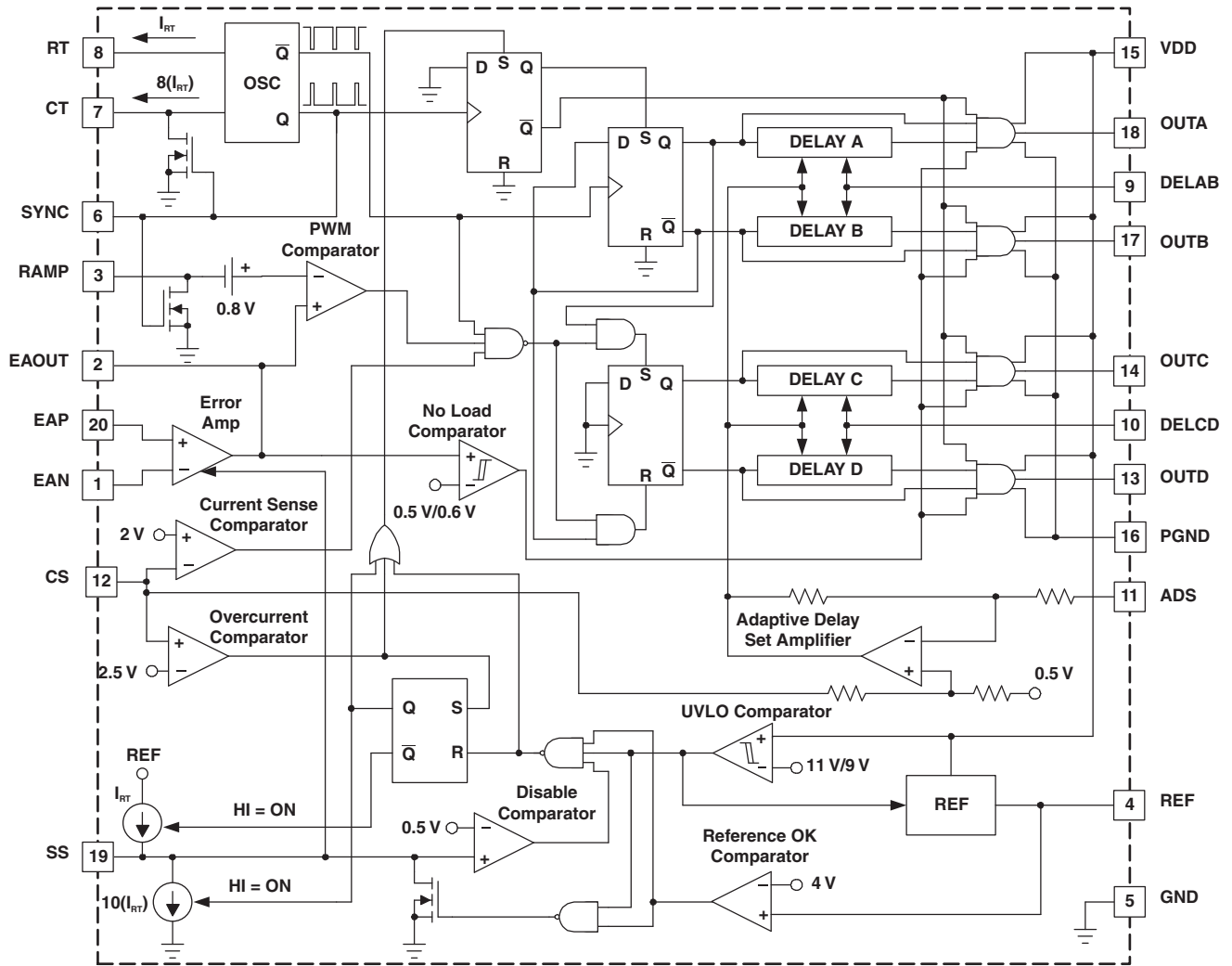

Figure 1. Oscillator Block Diagram

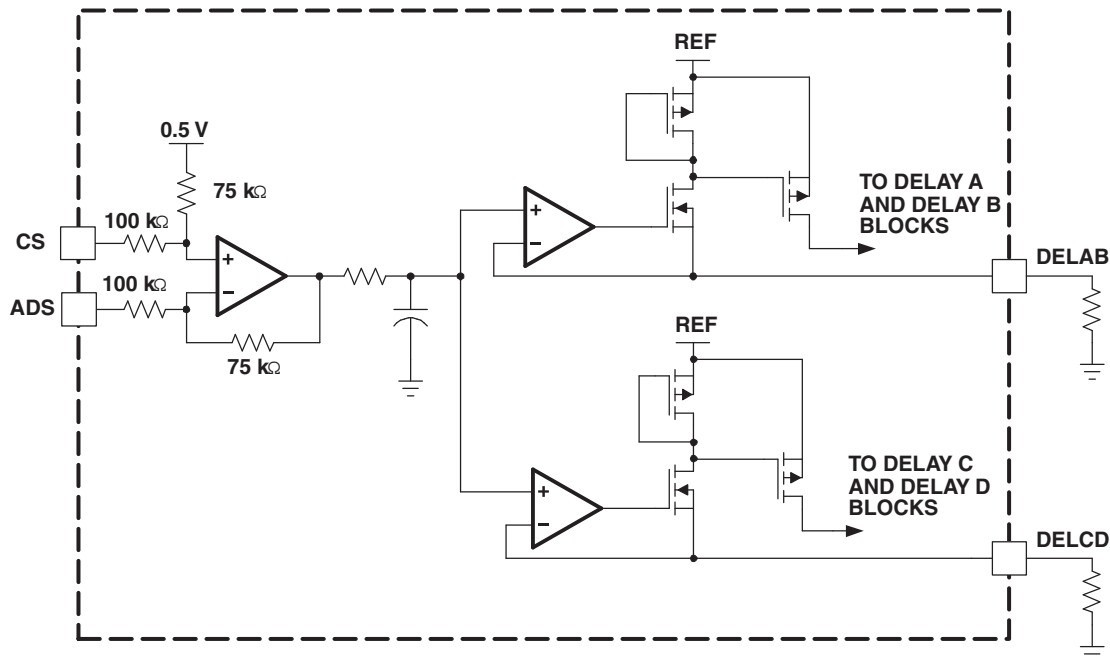

Figure 2. Adaptive Delay Setting Block Diagram

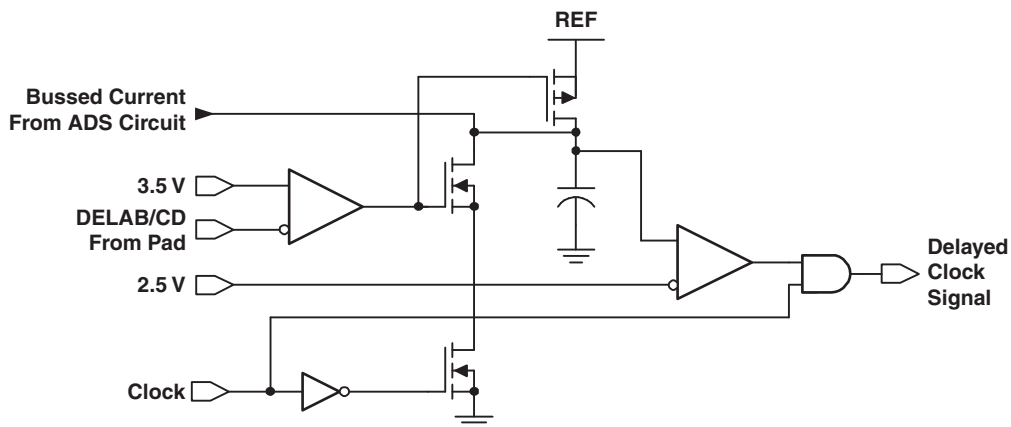

Figure 3. Delay Block Diagram (One Delay Block Per Outlet)

## DETAILED PIN DESCRIPTIONS

### Adaptive Delay Set (ADS)

This function sets the ratio between the maximum and minimum programmed output-delay dead time. When the ADS pin is directly connected to the CS pin, no delay modulation occurs. The maximum delay modulation occurs when ADS is grounded. In this case, delay time is four times longer when CS = 0 than when CS = 2 V (the peak-current threshold); ADS changes the output voltage on the delay pins DELAB and DELCD by [Equation 1](#):

$$V_{\text{DEL}} = [0.75 \times (V_{\text{CS}} - V_{\text{ADS}})] + 0.5 \text{ V} \quad (1) \quad (1)$$

where  $V_{\text{CS}}$  and  $V_{\text{ADS}}$  are in volts. ADS must be limited to between 0 V and 2.5 V and must be less than or equal to CS. DELAB and DELCD are clamped to a minimum of 0.5 V.

### Current Sense (CS)

CS is the inverting input of the current-sense comparator and the noninverting input of the overcurrent comparator and the ADS amplifier. The current-sense signal is used for cycle-by-cycle current limiting in peak-current mode control, and for overcurrent protection in all cases with a secondary threshold for output shutdown. An output disable initiated by an overcurrent fault also results in a restart cycle, called soft stop, with full soft start.

### Oscillator Timing Capacitor (CT)

The oscillator charges CT via a programmed current. The waveform on CT is a sawtooth, with a peak voltage of 2.35 V. The approximate oscillator period is calculated by [Equation 2](#):

$$t_{\text{OSC}} = [(5 \times R_T \times C_T)/48] + 120 \text{ ns} \quad (2) \quad (2)$$

where  $C_T$  is in farads,  $R_T$  is in  $\Omega$ , and  $t_{\text{OSC}}$  is in seconds.  $C_T$  can range from 100 pF to 880 pF.

#### NOTE

A large  $C_T$  and a small  $R_T$  combination results in extended fall times on the CT waveform. The increased fall time increases the SYNC pulse duration, hence limiting the maximum phase shift between OUTA, OUTB and OUTC, OUTD outputs, which limits the maximum duty cycle of the converter (see [Figure 1](#)).

### Delay Programming Between Complementary Outputs (DELAB, DELCD)

DELAB programs the dead time between switching of OUTA and OUTB, and DELCD programs the dead time between OUTC and OUTD. This delay is introduced between complementary outputs in the same leg of the external bridge. The UCC2895N allows the user to select the delay, during which the resonant switching of the external power stages takes place. Separate delays are provided for the two half bridges to accommodate differences in resonant-capacitor charging currents. The delay in each stage is set according to [Equation 3](#):

$$t_{\text{DELAY}} = [(25 \times 10^{-12} \times R_{\text{DEL}})/V_{\text{DEL}}] + 25 \text{ ns} \quad (3) \quad (3)$$

where  $V_{\text{DEL}}$  is in volts,  $R_{\text{DEL}}$  is in ohms, and  $t_{\text{DELAY}}$  is in seconds. DELAB and DELCD can source approximately 1 mA maximum. Choose the delay resistors so that this maximum is not exceeded. Programmable output delay is defeated by tying DELAB and/or DELCD to REF. For optimum performance, keep stray capacitance on these pins at less than 10 pF.

### Error Amplifier (EAOUT, EAP, EAN)

EAOUT is connected internally to the noninverting input of the PWM comparator and the no-load comparator. EAOUT is internally clamped to the soft-start voltage. The no-load comparator shuts down the output stages when EAOUT falls below 500 mV, and allows the outputs to turn on again when EAOUT rises above 600 mV.

EAP is the noninverting input and the EAN is the inverting input to the error amplifier.

## Output MOSFET Drivers (OUTA, OUTB, OUTC, OUTD)

The four outputs are 100-mA CMOS drivers and are optimized to drive MOSFET driver circuits. OUTA and OUTB are fully complementary, assuming no programming delay. They operate near 50% duty cycle and one-half the oscillator frequency. OUTA and OUTB are intended to drive one half-bridge circuit in an external power stage. OUTC and OUTD drive the other half-bridge circuit and have the same characteristics as OUTA and OUTB. OUTC is phase shifted with respect to OUTA, and OUTD is phase shifted with respect to OUTB.

---

### NOTE

Changing the phase relationship of OUTC and OUTD with respect to OUTA and OUTB requires other than the nominal 50% duty ratio on OUTC and OUTD during those transients.

---

## Power Ground (PGND)

To keep output switching noise from critical analog circuits, the UCC2895-Q1 has two different ground connections. PGND is the ground connection for the high-current output stages. Both GND and PGND must be electrically tied together. Also, because PGND carries high current, board traces must be low-impedance.

## Inverting Input of the PWM Comparator (RAMP)

This pin receives either the CT waveform in voltage control and average-current-mode control or the current signal (plus slope compensation) in peak-current-mode control.

## Voltage Reference (REF)

The 5 V  $\pm$  1.2% reference supplies power to internal circuitry, and can also supply up to 5 mA to external loads. The reference is shut down during undervoltage lockout (UVLO) but is operational during all other disable modes. For best performance, bypass with a 0.1- $\mu$ F low-ESR low-ESL capacitor to GND. Do not use more than 1  $\mu$ F of total capacitance on this pin to ensure the stability of the internal reference.

## Oscillator Timing Resistor (RT)

The oscillator operates by charging an external timing capacitor ( $C_T$ ) with a fixed current programmed by  $R_T$ .  $R_T$  current is calculated by [Equation 4](#):

$$I_{RT}(A) = 3 V / R_T (\Omega) \quad (4) \quad (4)$$

$R_T$  can range from 40 k $\Omega$  to 120 k $\Omega$ . Soft-start charging and discharging currents are also programmed by  $I_{RT}$  (see [Figure 1](#)).

## Analog Ground (GND)

This pin is the ground for all internal circuits except the output stages.

### Soft Start/Disable (SS/DISB)

This pin combines two independent functions.

**Disable Mode:** A rapid shutdown of the chip is accomplished by externally forcing SS/DISB below 0.5 V, externally forcing REF below 4 V, or if VDD drops below the UVLO threshold. In the case of REF being pulled below 4 V or an undervoltage condition, SS/DISB is actively pulled to ground via an internal MOSFET switch.

If an overcurrent fault is sensed ( $CS = 2.5\text{ V}$ ), a soft stop is initiated. In this mode, SS/DISB sinks a constant current of  $10 \times I_{RT}$ . The soft stop continues until SS/DISB falls below 0.5 V. When any of these faults is detected, all outputs are forced to ground immediately.

---

#### NOTE

If SS/DISB is forced below 0.5 V, the pin starts to source current equal to  $I_{RT}$ . The only time the device switches into low  $I_{DD}$  current mode is when the device is in UVLO.

---

**Soft-Start Mode:** After a fault or disable condition has passed, VDD is above the start threshold, or SS/DISB falls below 0.5 V during a soft stop, SS/DISB switches to a soft-start mode. The pin then sources current equal to  $I_{RT}$ . A user-selected resistor-and-capacitor combination on SS/DISB determines the soft-start time constant.

---

#### NOTE

SS/DISB actively clamps the EAOUT pin voltage to approximately the SS/DISB pin voltage during both soft-start, soft-stop, and disable conditions.

---

### Oscillator Synchronization (SYNC)

This pin is bidirectional (see [Figure 1](#)). When used as an output, SYNC can be used as a clock, which is the same as the internal clock of the device. When used as an input, SYNC overrides the internal oscillator of the device and acts as its clock signal. This bidirectional feature allows synchronization of multiple power supplies. Also, the SYNC signal internally discharges the  $C_T$  capacitor and any filter capacitors that are present on the RAMP pin. The internal SYNC circuitry is level-sensitive, with an input-low threshold of 1.9 V and an input-high threshold of 2.1 V. A resistor as small as 3.9 k $\Omega$  may be tied between SYNC and GND to reduce the SYNC pulse duration.

### Chip Supply (VDD)

This is the input pin to the chip. VDD must be bypassed with a minimum of 1- $\mu\text{F}$  low-ESR low-ESL capacitor to ground.

## APPLICATION INFORMATION

### Programming DELAB, DELCD, and ADS

The UCC2895N allows the user to set the delay between switch commands within each leg of the full-bridge power circuit according to Equation 5:

$$t_{\text{DELAY}} = [(25 \times 10^{-12} \times R_{\text{DEL}})/V_{\text{DEL}}] + 25 \text{ ns} \quad (5)$$

From Equation 5,  $V_{\text{DEL}}$  is determined in conjunction with the desire to use (or not use) the ADS feature from Equation 6:

$$V_{\text{DEL}} = [0.75 \times (V_{\text{CS}} - V_{\text{ADS}})] + 0.5 \text{ V} \quad (6)$$

Figure 4 illustrates the resistors needed to program the delay periods and the ADS function.

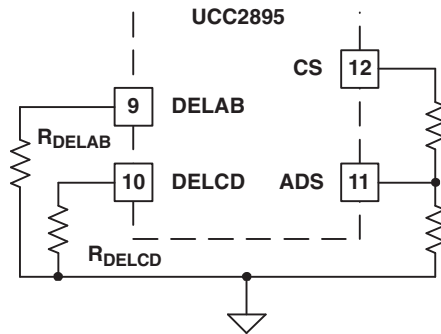

Figure 4. Programming Adaptive Delay Set

The ADS feature allows the user to vary the delay times between switch commands within each of the two legs of the converter. The delay-time modulation is implemented by connecting ADS (pin 11) to CS, GND, or a resistive divider from CS through ADS to GND to set  $V_{\text{ADS}}$  as shown in Figure 1. From Equation 6 for  $V_{\text{DEL}}$ , if ADS is tied to GND then  $V_{\text{DEL}}$  rises in direct proportion to  $V_{\text{CS}}$ , causing a decrease in  $t_{\text{DELAY}}$  as the load increases. In this condition, the maximum value of  $V_{\text{DEL}}$  is 2 V.

If ADS is connected to a resistive divider between CS and GND, the term  $(V_{\text{CS}} - V_{\text{ADS}})$  becomes smaller, reducing the level of  $V_{\text{DEL}}$ . This decreases the amount of delay modulation. In the limit of ADS tied to CS,  $V_{\text{DEL}} = 0.5 \text{ V}$ , and no delay modulation occurs. Figure 5 shows the delay time versus load for varying adaptive-delay-set feature voltages ( $V_{\text{ADS}}$ ).

In the case of maximum delay modulation (ADS = GND), when the circuit goes from light load to heavy load, the variation of  $V_{\text{DEL}}$  is from 0.5 V to 2 V. This causes the delay times to vary by a 4:1 ratio as the load is changed.

The ability to program an adaptive delay is a desirable feature, because the optimum delay time is a function of the current flowing in the primary winding of the transformer and can change by a factor of 10:1 or more as circuit loading changes. Reference [5] describes the many interrelated factors for choosing the optimum delay times for the most-efficient power conversion, and illustrates an external circuit to enable adaptive delay set using the UC3879. Implementing this adaptive feature is simplified in the UCC2895-Q1 controller, giving the user the ability to tailor the delay times to suit a particular application with a minimum of external parts.

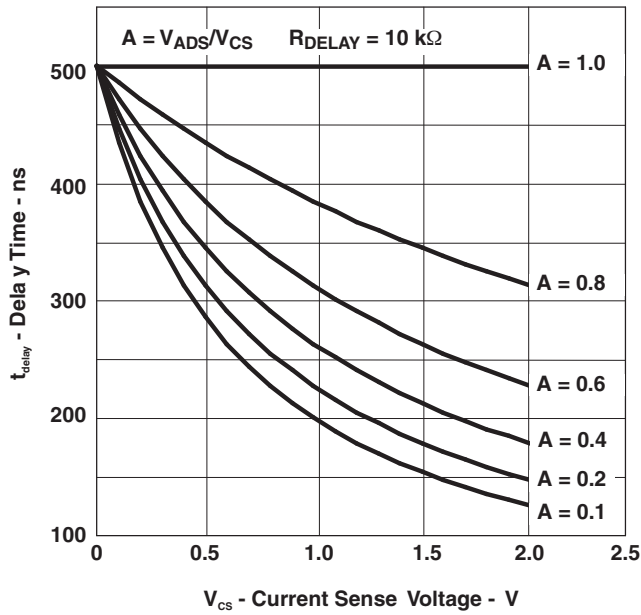

Figure 5. Delay Time Under Varying ADS Voltages

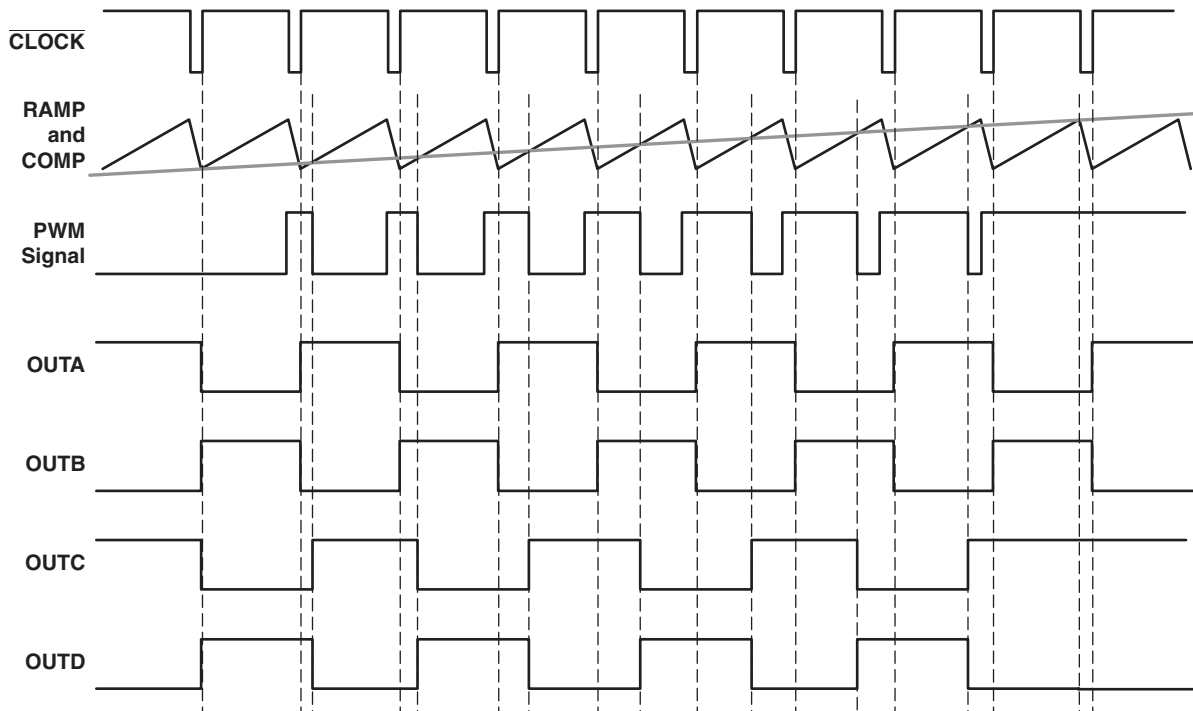

Figure 6. Timing Diagram (No Output Delay Shown, COMP to RAMP Offset Not Included)

TYPICAL CHARACTERISTICS

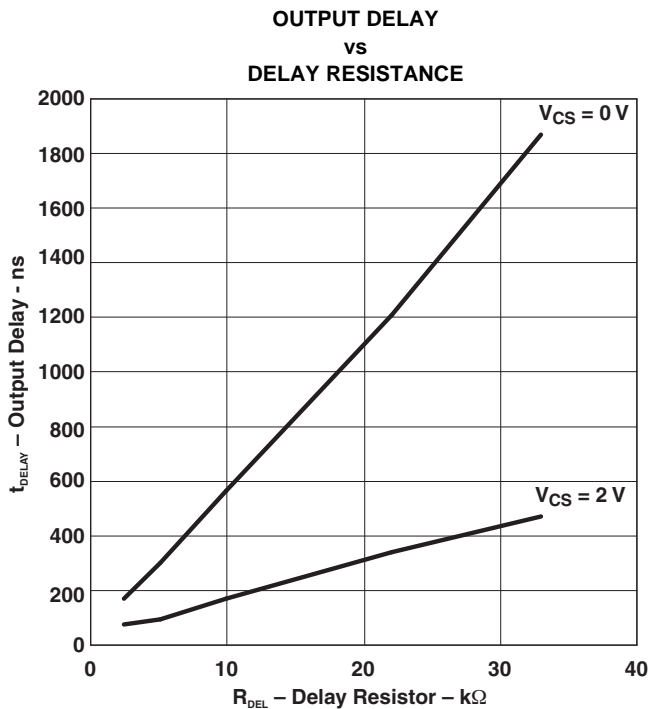

Figure 7.

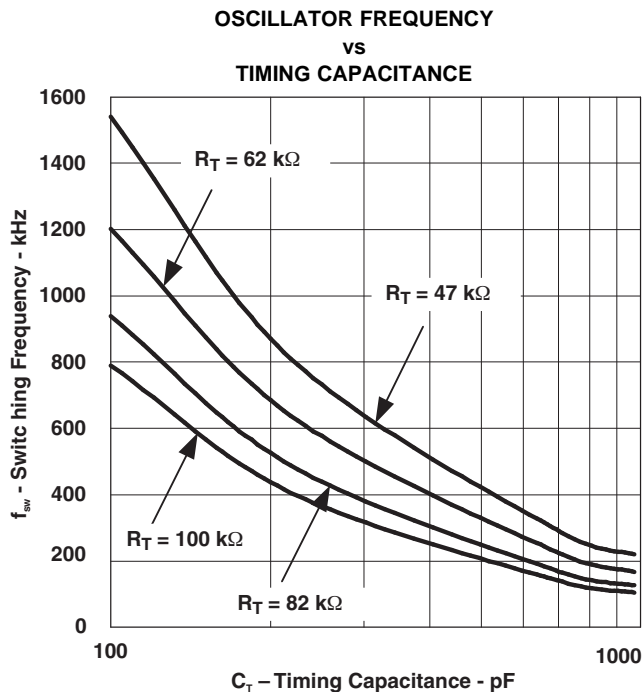

Figure 8.

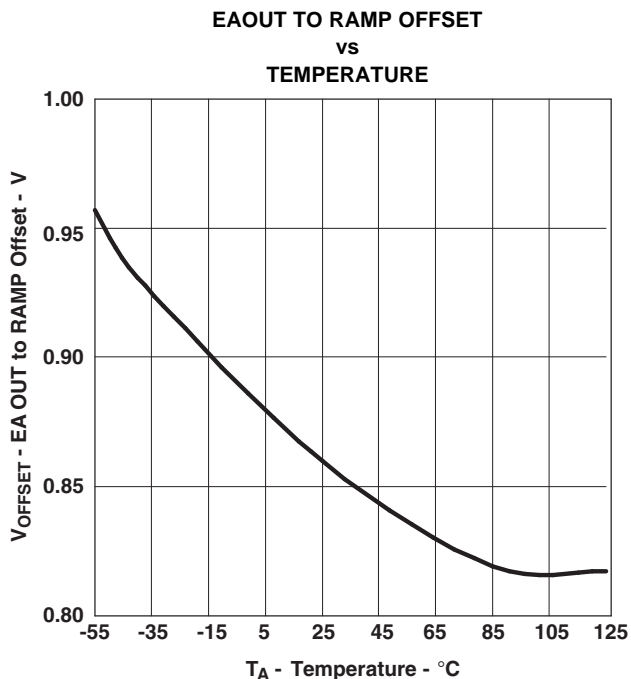

Figure 9.

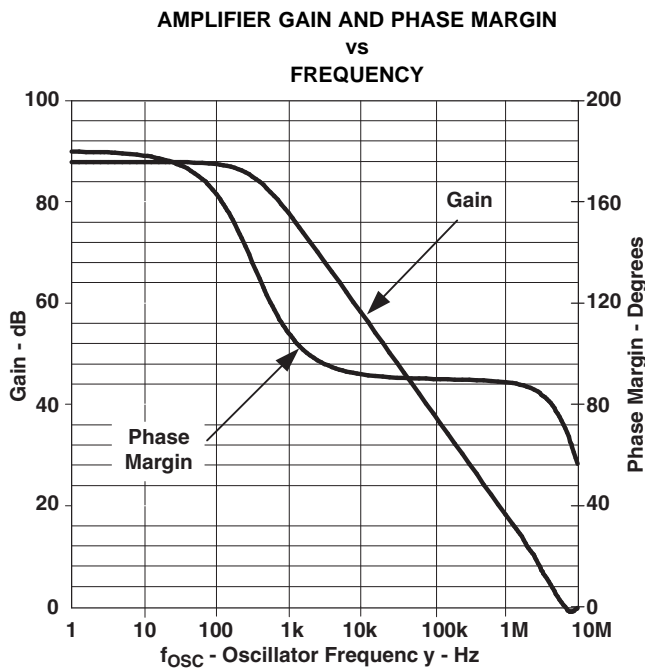

Figure 10.

### TYPICAL CHARACTERISTICS (continued)

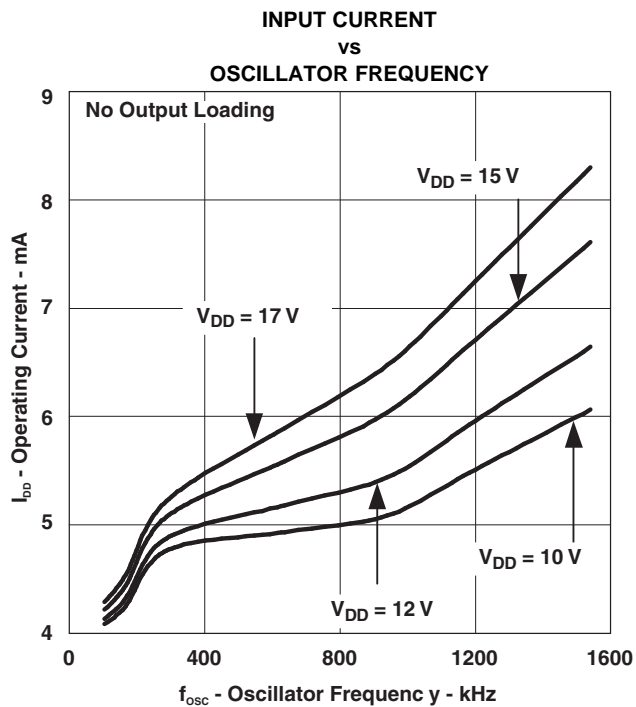

Figure 11.

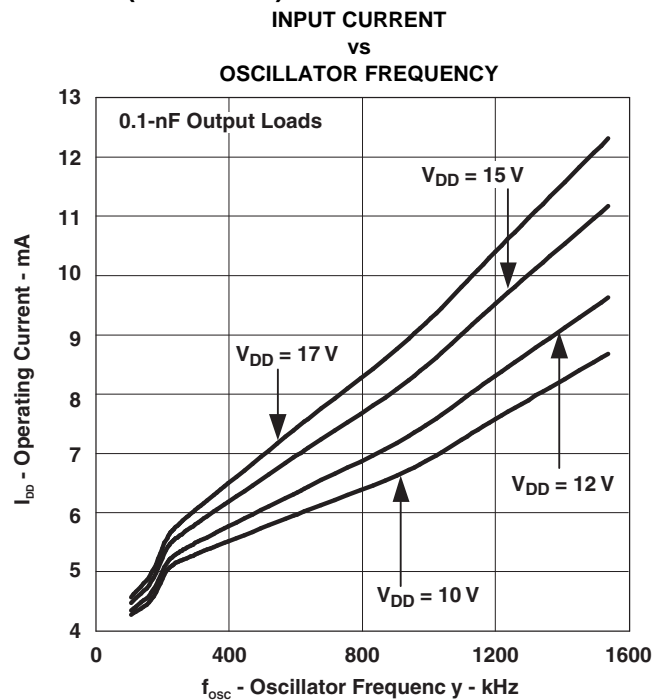

Figure 12.

### REFERENCES

1. M. Dennis, *A Comparison Between the BiCMOS UCC2895 Phase Shift Controller and the UC3875* (SLUA246)
2. L. Balogh, *The Current-Doubler Rectifier: An Alternative Rectification Technique For Push-Pull and Bridge Converters* (SLUA121)
3. W. Andreyca, *Phase Shifted, Zero Voltage Transition Design Considerations and the UC3875 PWM Controller* (SLUA107)
4. L. Balogh, *The New UC3879 Phase-Shifted PWM Controller Simplifies the Design of Zero Voltage Transition Full-Bridge Converters* (SLUA122)
5. L. Balogh, *Design Review: 100 W, 400 kHz, dc-to-dc Converter with Current Doubler Synchronous Rectification Achieves 92% Efficiency*, Unitrode Power Supply Design Seminar Manual, SEM-1100, 1996, Topic 2.
6. UC3875 Phase Shift Resonant Controller data sheet (SLUS229)
7. UC3879 Phase Shift Resonant Controller data sheet (SLUS230)
8. *Configuring the UCC2895 for Direct Control Driven Synchronous Rectification* (SLUU109)
9. S. Mappus, *UCC2895 OUTC/OUTD Asymmetric Duty Cycle Operation* (SLUA275)
10. S. Mappus, *Current Doubler Rectifier Offers Ripple Current Cancellation* (SLUA323)
11. S. Mappus, *Control Driven Synchronous Rectifiers In Phase Shifted Full Bridge Converters* (SLUA287)

---

**REVISION HISTORY**

<b>Changes from Revision B (July 2012) to Revision C</b>	<b>Page</b>
• Changed $T_J$ from $-40^{\circ}\text{C}$ to $-55^{\circ}\text{C}$ .....	<a href="#">2</a>
• Changed $T_J$ from $-40^{\circ}\text{C}$ to $-55^{\circ}\text{C}$ .....	<a href="#">3</a>

---

**PACKAGING INFORMATION**

Orderable Device	Status (1)	Package Type	Package Drawing	Pins	Package Qty	Eco Plan (2)	Lead/Ball Finish	MSL Peak Temp (3)	Op Temp (°C)	Top-Side Markings (4)	Samples
UCC2895QDWRQ1	ACTIVE	SOIC	DW	20	2000	Green (RoHS & no Sb/Br)	CU NIPDAU	Level-2-260C-1 YEAR	-40 to 125	UCC2895Q	<a href="#">Samples</a>

(1) The marketing status values are defined as follows:

**ACTIVE:** Product device recommended for new designs.

**LIFEBUY:** TI has announced that the device will be discontinued, and a lifetime-buy period is in effect.

**NRND:** Not recommended for new designs. Device is in production to support existing customers, but TI does not recommend using this part in a new design.

**PREVIEW:** Device has been announced but is not in production. Samples may or may not be available.

**OBSOLETE:** TI has discontinued the production of the device.

(2) Eco Plan - The planned eco-friendly classification: Pb-Free (RoHS), Pb-Free (RoHS Exempt), or Green (RoHS & no Sb/Br) - please check <http://www.ti.com/productcontent> for the latest availability information and additional product content details.

**TBD:** The Pb-Free/Green conversion plan has not been defined.

**Pb-Free (RoHS):** TI's terms "Lead-Free" or "Pb-Free" mean semiconductor products that are compatible with the current RoHS requirements for all 6 substances, including the requirement that lead not exceed 0.1% by weight in homogeneous materials. Where designed to be soldered at high temperatures, TI Pb-Free products are suitable for use in specified lead-free processes.

**Pb-Free (RoHS Exempt):** This component has a RoHS exemption for either 1) lead-based flip-chip solder bumps used between the die and package, or 2) lead-based die adhesive used between the die and leadframe. The component is otherwise considered Pb-Free (RoHS compatible) as defined above.

**Green (RoHS & no Sb/Br):** TI defines "Green" to mean Pb-Free (RoHS compatible), and free of Bromine (Br) and Antimony (Sb) based flame retardants (Br or Sb do not exceed 0.1% by weight in homogeneous material)

(3) MSL, Peak Temp. -- The Moisture Sensitivity Level rating according to the JEDEC industry standard classifications, and peak solder temperature.

(4) Multiple Top-Side Markings will be inside parentheses. Only one Top-Side Marking contained in parentheses and separated by a "~" will appear on a device. If a line is indented then it is a continuation of the previous line and the two combined represent the entire Top-Side Marking for that device.

**Important Information and Disclaimer:** The information provided on this page represents TI's knowledge and belief as of the date that it is provided. TI bases its knowledge and belief on information provided by third parties, and makes no representation or warranty as to the accuracy of such information. Efforts are underway to better integrate information from third parties. TI has taken and continues to take reasonable steps to provide representative and accurate information but may not have conducted destructive testing or chemical analysis on incoming materials and chemicals. TI and TI suppliers consider certain information to be proprietary, and thus CAS numbers and other limited information may not be available for release.

In no event shall TI's liability arising out of such information exceed the total purchase price of the TI part(s) at issue in this document sold by TI to Customer on an annual basis.

**OTHER QUALIFIED VERSIONS OF UCC2895-Q1 :**

- Catalog: [UCC2895](#)

- Enhanced Product: [UCC2895-EP](#)

NOTE: Qualified Version Definitions:

- Catalog - TI's standard catalog product
- Enhanced Product - Supports Defense, Aerospace and Medical Applications

## TAPE AND REEL INFORMATION



### QUADRANT ASSIGNMENTS FOR PIN 1 ORIENTATION IN TAPE



\*All dimensions are nominal

Device	Package Type	Package Drawing	Pins	SPQ	Reel Diameter (mm)	Reel Width W1 (mm)	A0 (mm)	B0 (mm)	K0 (mm)	P1 (mm)	W (mm)	Pin1 Quadrant
UCC2895QDWRQ1	SOIC	DW	20	2000	330.0	24.4	10.8	13.3	2.7	12.0	24.0	Q1

**TAPE AND REEL BOX DIMENSIONS**

\*All dimensions are nominal

Device	Package Type	Package Drawing	Pins	SPQ	Length (mm)	Width (mm)	Height (mm)
UCC2895QDWRQ1	SOIC	DW	20	2000	367.0	367.0	45.0

# DW0020A



# PACKAGE OUTLINE

## SOIC - 2.65 mm max height

SOIC



4220724/A 05/2016

**NOTES:**

1. All linear dimensions are in millimeters. Dimensions in parenthesis are for reference only. Dimensioning and tolerancing per ASME Y14.5M.
2. This drawing is subject to change without notice.
3. This dimension does not include mold flash, protrusions, or gate burrs. Mold flash, protrusions, or gate burrs shall not exceed 0.15 mm per side.
4. This dimension does not include interlead flash. Interlead flash shall not exceed 0.43 mm per side.
5. Reference JEDEC registration MS-013.

# EXAMPLE BOARD LAYOUT

DW0020A

SOIC - 2.65 mm max height

SOIC



LAND PATTERN EXAMPLE  
SCALE:6X



SOLDER MASK DETAILS

4220724/A 05/2016

NOTES: (continued)

- 6. Publication IPC-7351 may have alternate designs.
- 7. Solder mask tolerances between and around signal pads can vary based on board fabrication site.

# EXAMPLE STENCIL DESIGN

DW0020A

SOIC - 2.65 mm max height

SOIC



SOLDER PASTE EXAMPLE  
BASED ON 0.125 mm THICK STENCIL  
SCALE:6X

4220724/A 05/2016

NOTES: (continued)

8. Laser cutting apertures with trapezoidal walls and rounded corners may offer better paste release. IPC-7525 may have alternate design recommendations.
9. Board assembly site may have different recommendations for stencil design.

## IMPORTANT NOTICE AND DISCLAIMER

TI PROVIDES TECHNICAL AND RELIABILITY DATA (INCLUDING DATASHEETS), DESIGN RESOURCES (INCLUDING REFERENCE DESIGNS), APPLICATION OR OTHER DESIGN ADVICE, WEB TOOLS, SAFETY INFORMATION, AND OTHER RESOURCES "AS IS" AND WITH ALL FAULTS, AND DISCLAIMS ALL WARRANTIES, EXPRESS AND IMPLIED, INCLUDING WITHOUT LIMITATION ANY IMPLIED WARRANTIES OF MERCHANTABILITY, FITNESS FOR A PARTICULAR PURPOSE OR NON-INFRINGEMENT OF THIRD PARTY INTELLECTUAL PROPERTY RIGHTS.

These resources are intended for skilled developers designing with TI products. You are solely responsible for (1) selecting the appropriate TI products for your application, (2) designing, validating and testing your application, and (3) ensuring your application meets applicable standards, and any other safety, security, or other requirements. These resources are subject to change without notice. TI grants you permission to use these resources only for development of an application that uses the TI products described in the resource. Other reproduction and display of these resources is prohibited. No license is granted to any other TI intellectual property right or to any third party intellectual property right. TI disclaims responsibility for, and you will fully indemnify TI and its representatives against, any claims, damages, costs, losses, and liabilities arising out of your use of these resources.

TI's products are provided subject to TI's Terms of Sale ([www.ti.com/legal/termsofsale.html](http://www.ti.com/legal/termsofsale.html)) or other applicable terms available either on [ti.com](http://ti.com) or provided in conjunction with such TI products. TI's provision of these resources does not expand or otherwise alter TI's applicable warranties or warranty disclaimers for TI products.

Mailing Address: Texas Instruments, Post Office Box 655303, Dallas, Texas 75265  
Copyright © 2019, Texas Instruments Incorporated

## Looking for pricing, stock, or lifecycle information?

Click below to explore more details on WIN SOURCE:

 [View UCC2895QDWRQ1](#) on WIN SOURCE

 [Texas Instruments](#) Information

## Optimize Your Supply Chain with WIN SOURCE Solutions

-  Global Sourcing Solution
-  Obsolete Management
-  Cost Control Management
-  Shortage Management
-  Alternative Solution
-  Excess Inventory Management