



**THE DATASHEET OF
TPS65631DPDR**



TPS65631 Dual-Output AMOLED Display Power Supply

1 Features

- 2.9-V to 4.5-V Input Voltage Range
- Fixed 4.6-V Positive Output Voltage
- 0.5% V_{POS} Accuracy from 25°C to 85°C
- Separate V_{POS} Output Sense Pin
- Negative Output Voltage Digitally Programmable from -1.4 V to -4.4 V (-4 V Default)
- Output Currents up to 250 mA Supported
- Excellent Line Transient Regulation
- Short-Circuit Protection
- Thermal Shutdown
- Available in 3.00-mm x 3.00-mm, 12-Pin QFN Package

2 Applications

AMOLED Displays

3 Description

The TPS65631 is designed to drive AMOLED (Active Matrix Organic Light Emitting Diode) displays requiring positive and negative supply rails. The device integrates a boost converter for V_{POS} and an inverting buck boost converter for V_{NEG} and is suitable for battery-operated products. The digital control pin (CTRL) allows programming the negative output voltage in digital steps. The TPS65631 uses a novel technology enabling excellent line transient performance.

Device Information⁽¹⁾

PART NUMBER	PACKAGE	BODY SIZE (NOM)
TPS65631	QFN (12)	3.00 mm x 3.00 mm

(1) For all available packages, see the orderable addendum at the end of the data sheet

4 Simplified Schematic

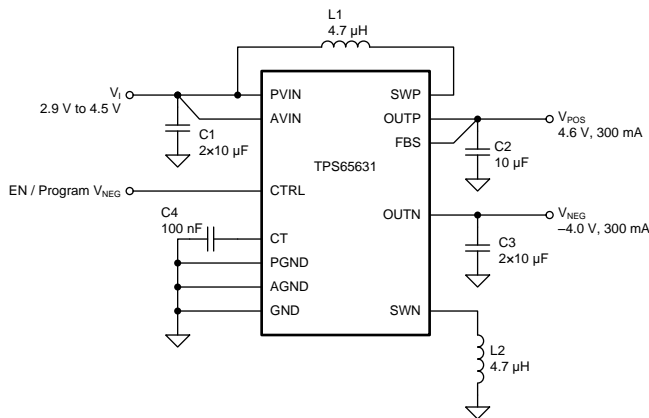

Efficiency vs Output Current

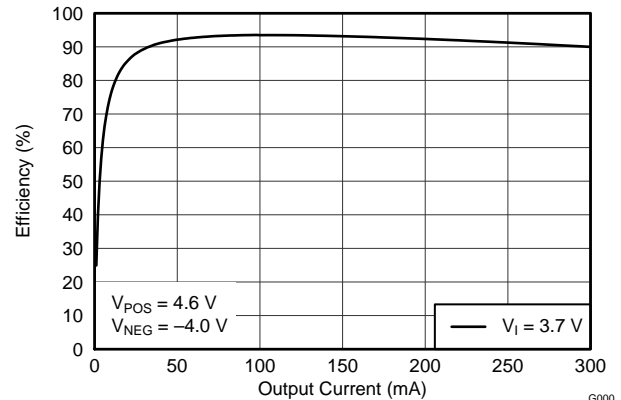

G000



Table of Contents

1 Features	1	8.2 Functional Block Diagram	8
2 Applications	1	8.3 Feature Description	8
3 Description	1	8.4 Device Functional Modes	12
4 Simplified Schematic	1	9 Applications and Implementation	12
5 Revision History	2	9.1 Application Information	12
6 Pin Configuration and Functions	3	9.2 Typical Application	12
7 Specifications	4	10 Power Supply Recommendations	16
7.1 Absolute Maximum Ratings	4	11 Layout	17
7.2 Handling Ratings	4	11.1 Layout Guidelines	17
7.3 Recommended Operating Conditions	4	11.2 Layout Example	17
7.4 Thermal Information	4	12 Device and Documentation Support	18
7.5 Electrical Characteristics	5	12.1 Device Support	18
7.6 Timing Requirements	6	12.2 Trademarks	18
7.7 Typical Characteristics	7	12.3 Electrostatic Discharge Caution	18
8 Detailed Description	8	12.4 Glossary	18
8.1 Overview	8	13 Mechanical, Packaging, and Orderable Information	18

5 Revision History

DATE	REVISION	NOTES
May 2014	E	No legacy rev history for rev E – first public release

6 Pin Configuration and Functions

**DPD PACKAGE
(TOP VIEW)**

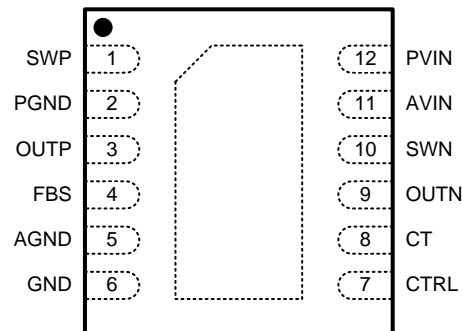

**DPD PACKAGE
(BOTTOM VIEW)**

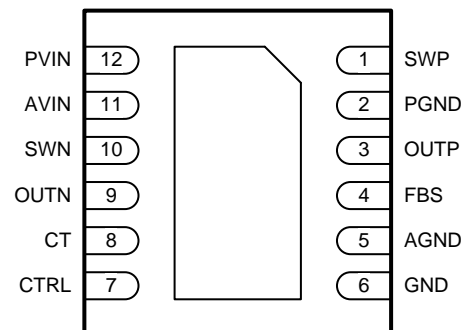

Pin Functions

NAME	NO.	I/O	DESCRIPTION
AGND	5	—	Analog ground.
AVIN	11	—	Input supply voltage for internal analog circuits (both converters).
CT	8	I/O	Timing capacitor pin. Connect a capacitor between this pin and ground to control the time it takes for the output of the inverting buck-boost converter to ramp from one value of V_{NEG} to another.
CTRL	7	I	Control pin. Combined device enable and inverting buck-boost converter output voltage programming pin.
FBS	4	I	Feedback sense pin of the boost converter output voltage.
GND	6	—	Ground. (Note: it is possible to leave this pin floating without affecting device performance.)
PGND	2	—	Power ground of the boost converter.
PVIN	12	—	Input supply voltage pin for the inverting buck-boost converter.
SWN	10	O	Switch pin of the inverting buck-boost converter.
SWP	1	O	Switch pin of the boost converter.
OUTN	9	O	Rectifier pin of the inverting buck-boost converter.
OUTP	3	O	Rectifier pin of the boost converter.
Exposed Thermal Pad	13	—	Connect this pad to AGND and PGND.

7 Specifications

7.1 Absolute Maximum Ratings ⁽¹⁾

over operating free-air temperature range (unless otherwise noted) ⁽¹⁾

		MIN	MAX	UNIT
Input voltage ⁽²⁾	SWP, OUTP, FBS, PVIN, AVIN	-0.3	6	V
	OUTN	-0.3	-6	V
	SWN	-6	6	V
	CTRL	-0.3	5.5	V
	CT	-0.3	3.6	V
Operating junction temperature range, T _J		-40	150	°C

(1) Stresses beyond those listed under *Absolute Maximum Ratings* may cause permanent damage to the device. These are stress ratings only, which do not imply functional operation of the device at these or any other conditions beyond those indicated under *Recommended Operating Conditions*. Exposure to absolute-maximum-rated conditions for extended periods may affect device reliability.

(2) With respect to GND pin.

7.2 Handling Ratings

		MIN	MAX	UNIT	
T _{STG}	Storage temperature range	-65	150	°C	
V _{ESD}	Electrostatic discharge	Human body model (HBM), per ANSI/ESDA/JEDEC JS-001, all pins ⁽¹⁾	-2	2	kV
		Charged device model (CDM), per JEDEC specification JESD22-C101, all pins ⁽²⁾	-500	500	V
		Machine model (MM) ESD stress voltage	-200	200	V

(1) JEDEC document JEP155 states that 500-V HBM allows safe manufacturing with a standard ESD control process.

(2) JEDEC document JEP157 states that 250-V CDM allows safe manufacturing with a standard ESD control process..

7.3 Recommended Operating Conditions

over operating free-air temperature range (unless otherwise noted)

PARAMETER		MIN	NOM	MAX	UNIT
V _I	Input supply voltage range	2.9	3.7	4.5	V
V _O	Output voltage range	V _{POS}		4.6	V
		V _{NEG}		-4.4 -4 -1.4	
I _O	Output current range	I _{POS}		300	mA
		I _{NEG}		300	
T _A	Operating ambient temperature	-40	25	85	°C
T _J	Operating junction temperature	-40	85	125	°C

7.4 Thermal Information

THERMAL METRIC ⁽¹⁾		PD	UNIT
		12 PINS	
R _{θJA}	Junction-to-ambient thermal resistance	51.5	°C/W
R _{θJctop}	Junction-to-case (top) thermal resistance	47.1	
R _{θJB}	Junction-to-board thermal resistance	25.0	
ψ _{JT}	Junction-to-top characterization parameter	0.5	
ψ _{JB}	Junction-to-board characterization parameter	25.2	
R _{θJcbot}	Junction-to-case (bottom) thermal resistance	4.4	

(1) For more information about traditional and new thermal metrics, see the *IC Package Thermal Metrics* application report, [SPRA953](#).

7.5 Electrical Characteristics

$V_I = 3.7\text{ V}$, $V_{CTRL} = 3.7\text{ V}$, $V_{POS} = 4.6\text{ V}$, $V_{NEG} = -4.0\text{ V}$, $T_J = -40^\circ\text{C}$ to 125°C , typical values are at $T_A = 25^\circ\text{C}$ (unless otherwise noted)

PARAMETER		TEST CONDITIONS	MIN	TYP	MAX	UNIT
SUPPLY						
I_I	Shutdown current into AVIN and PVIN	CTRL pin connected to ground.		0.1		μA
V_{UVLO}	Undervoltage lockout threshold	V_I rising.			2.4	V
		V_I falling.			2.1	
BOOST CONVERTER						
V_O	Output voltage			4.6		V
	Output voltage tolerance	$25^\circ\text{C} \leq T_A \leq 85^\circ\text{C}$, no load	-0.5%		0.5%	
		$-40^\circ\text{C} \leq T_A < 85^\circ\text{C}$, no load	-0.8%		0.8%	
$r_{DS(ON)}$	Switch (low-side) on-resistance	$I_{(SWP)} = 200\text{ mA}$		200		m Ω
	Rectifier (high-side) on-resistance	$I_{(SWP)} = 200\text{ mA}$		350		
	Switching frequency	$I_O = 200\text{ mA}$		1.7		MHz
	Switch current limit	Inductor valley current	0.8	1		A
	Short-circuit threshold voltage in operation	V_O falling		4.1		V
	Short-circuit detection time during operation			3		ms
	Output sense threshold voltage using OUTP	$V_{(OUTP)} - V_{(FBS)}$ increasing		300		mV
	Output sense threshold voltage using FBS	$V_{(OUTP)} - V_{(FBS)}$ decreasing		200		mV
	Input resistance of FBS	Between FBS pin and ground		4		M Ω
	Discharge resistance	CTRL pin connected to ground, $I_O = 1\text{ mA}$		30		Ω
	Line regulation	$I_O = 200\text{ mA}$		0.002		%/V
	Load regulation			0.01		%/A
INVERTING BUCK-BOOST CONVERTER						
V_O	Output voltage default			-4.0		V
	Output voltage range		-4.4		-1.4	
	Output voltage tolerance		-0.05		0.05	
$r_{DS(ON)}$	Switch (high-side) on-resistance	$I_{(SWN)} = 200\text{ mA}$		200		m Ω
	Rectifier (low-side) on-resistance	$I_{(SWN)} = 200\text{ mA}$		300		
	Switching frequency	$I_O = 10\text{ mA}$		1.7		MHz
	Switch current limit	$V_I = 2.9\text{ V}$	1.5	2.2		A
	Short-circuit threshold voltage during operation	Voltage drop from nominal V_O		500		mV
	Short-circuit threshold voltage during start-up		180	200	230	
t_{SCP}	Short-circuit detection time during start-up			10		ms
	Short-circuit detection time during operation			3		ms
	Discharge resistance	CTRL pin connected to ground, $I_O = 1\text{ mA}$		150		Ω
	Line regulation	$I_O = 200\text{ mA}$		0.006		%/V
	Load regulation			0.31		%/A
CTRL						
	High-level threshold voltage				1.2	V
	Low-level threshold voltage		0.4			V

Electrical Characteristics (continued)

$V_I = 3.7\text{ V}$, $V_{(CTRL)} = 3.7\text{ V}$, $V_{POS} = 4.6\text{ V}$, $V_{NEG} = -4.0\text{ V}$, $T_J = -40^\circ\text{C}$ to 125°C , typical values are at $T_A = 25^\circ\text{C}$ (unless otherwise noted)

PARAMETER		TEST CONDITIONS	MIN	TYP	MAX	UNIT
	Pull-down resistance		150	400	860	k Ω
OTHER						
$R_{(CT)}$	CT pin output resistance		150	300	500	k Ω
t_{INIT}	Initialization time			300	400	μs
t_{OFF}	Shut-down time		30		80	μs
t_{STORE}	Data storage time		30		80	μs
T_{SD}	Thermal shutdown temperature			145		$^\circ\text{C}$

7.6 Timing Requirements

		MIN	TYP	MAX	UNIT
CTRL Interface					
t_{HIGH}	High-level pulse duration	2	10	25	μs
t_{LOW}	Low-level pulse duration	2	10	25	μs

7.7 Typical Characteristics

At $T_A = 25^\circ\text{C}$, unless otherwise noted.

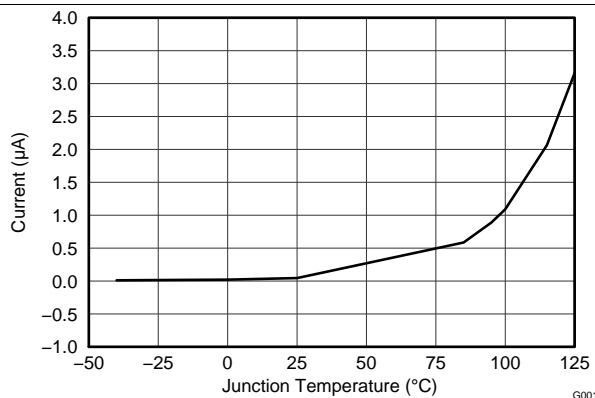

Figure 1. Shutdown Current into AVIN and PVIN

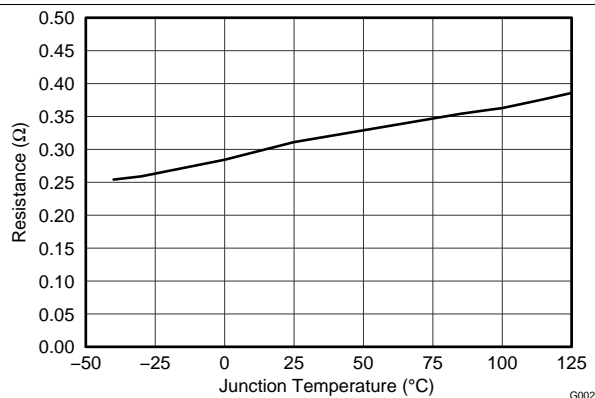

Figure 2. Boost Converter Switch $r_{DS(ON)}$

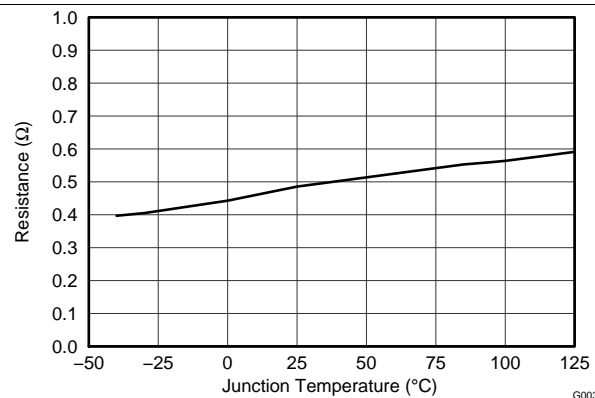

Figure 3. Boost Converter Rectifier $r_{DS(ON)}$

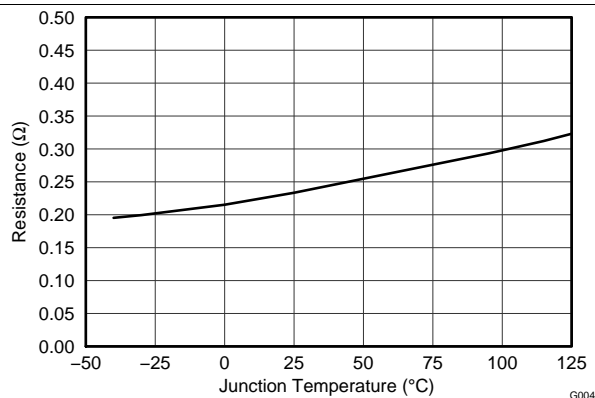

Figure 4. Inverting Buck-Boost Converter Switch $r_{DS(ON)}$

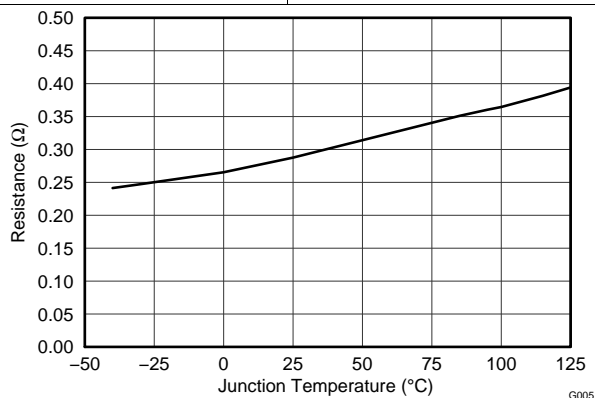

Figure 5. Inverting Buck-Boost Converter Rectifier $r_{DS(ON)}$

8 Detailed Description

8.1 Overview

The TPS65631 consists of a boost converter and an inverting buck boost converter. The V_{POS} output is fixed at 4.6 V and V_{NEG} output is programmable via a digital interface in the range of -1.4 V ~ -4.4 V, the default is -4 V. The transition time of V_{NEG} output is adjustable by the CT pin capacitor.

8.2 Functional Block Diagram

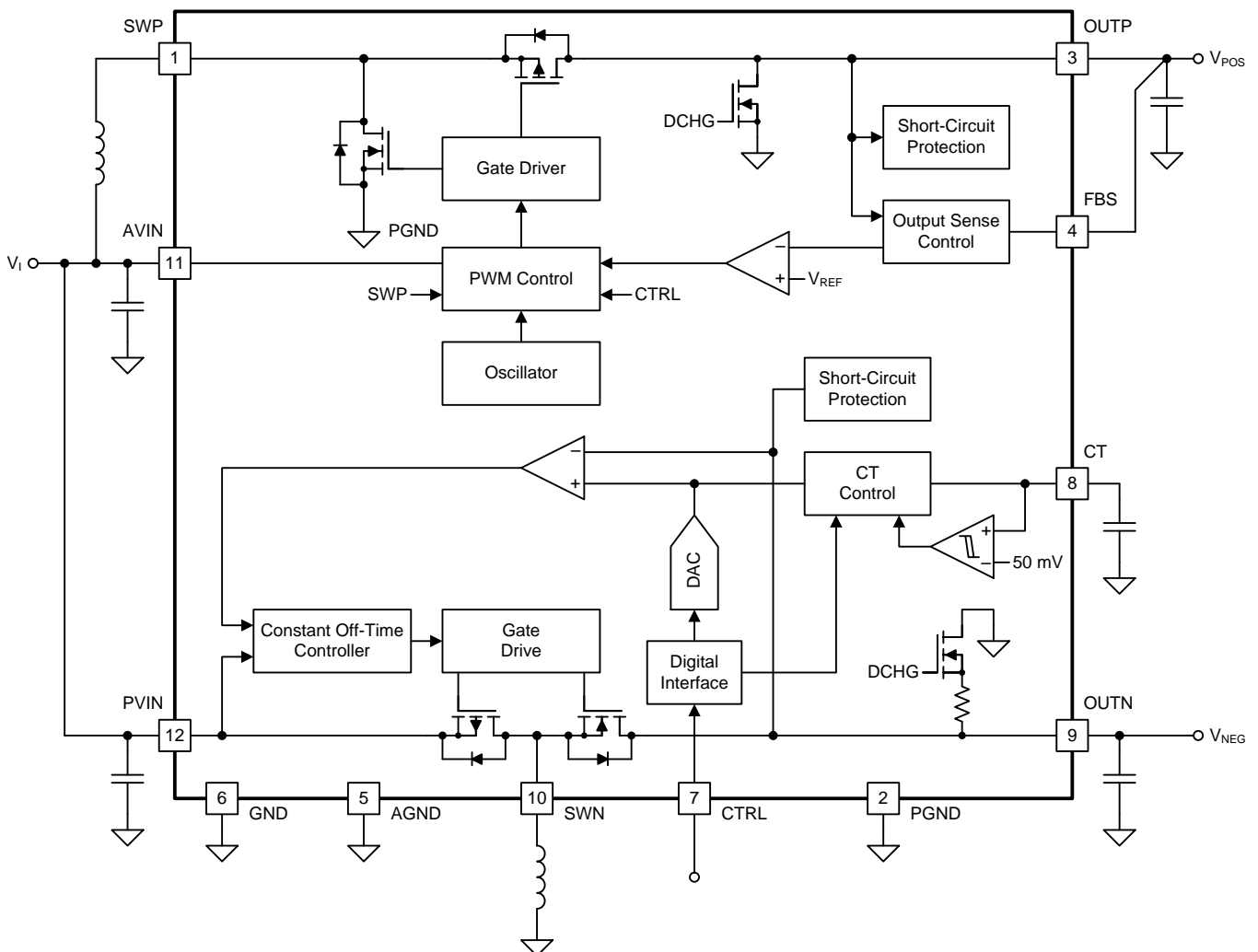

8.3 Feature Description

8.3.1 Boost Converter

The boost converter uses a fixed-frequency current-mode topology, and its output voltage (V_{POS}) is fixed at 4.6 V. For the highest output voltage accuracy, connect the output sense pin (FBS) directly to the positive pin of the output capacitor. If not used, the FBS pin can be left floating or connected to ground. If the FBS pin is not used, the boost converter senses its output voltage using the OUTP pin.

Feature Description (continued)

8.3.2 Inverting Buck-Boost Converter

The inverting buck-boost converter uses a constant-off-time peak-current mode topology. The converter's default output voltage (V_{NEG}) is -4 V , but it can be programmed to any voltage in the range -1.4 V to -4.4 V (see [Programming \$V_{NEG}\$](#)).

8.3.2.1 Programming V_{NEG}

The output voltage of the inverting buck-boost converter (V_{NEG}) can be programmed using the CTRL pin. If output voltage programming is not required, the CTRL pin can be used as a standard enable pin (see [Enable \(CTRL\)](#)).

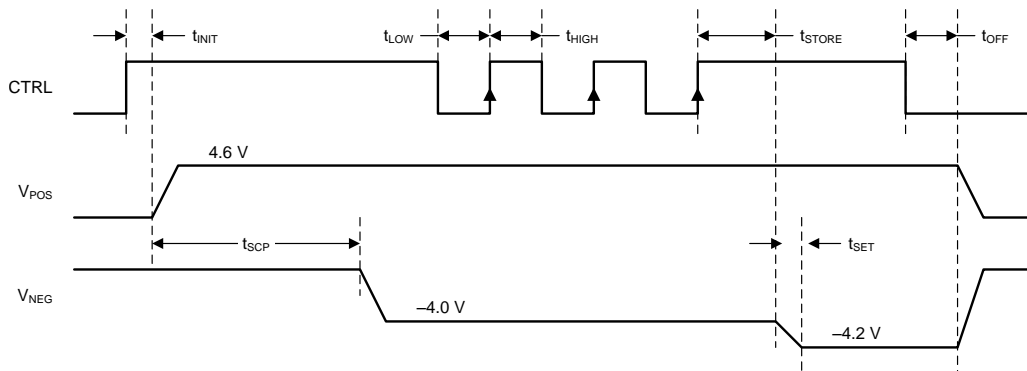

Figure 6. Programming V_{NEG} Using the CTRL Pin

When the CTRL pin is pulled high, the inverting buck-boost converter starts up with its default voltage of -4 V . The device now counts the rising edges applied to the CTRL pin and sets the output voltage (V_{NEG}) according to [Table 1](#). For the timing diagram shown in [Figure 6](#), V_{NEG} is programmed to -4.2 V , since three rising edges are detected.

The CTRL interface is designed to work with pulses whose duration is between $2\text{ }\mu\text{s}$ and $25\text{ }\mu\text{s}$. Pulses shorter than $2\text{ }\mu\text{s}$ or longer than $25\text{ }\mu\text{s}$ are not ensured to be recognized.

Table 1. Programming Table for V_{NEG}

Number of Rising Edges	V_{NEG}	Number of Rising Edges	V_{NEG}
0 / no pulses	-4 V	16	-2.9 V
1	-4.4 V	17	-2.8 V
2	-4.3 V	18	-2.7 V
3	-4.2 V	19	-2.6 V
4	-4.1 V	20	-2.5 V
5	-4.0 V	21	-2.4 V
6	-3.9 V	22	-2.3 V
7	-3.8 V	23	-2.2 V
8	-3.7 V	24	-2.1 V
9	-3.6 V	25	-2.0 V
10	-3.5 V	26	-1.9 V
11	-3.4 V	27	-1.8 V
12	-3.3 V	28	-1.7 V
13	-3.2 V	29	-1.6 V
14	-3.1 V	30	-1.5 V
15	-3.0 V	31	-1.4 V

8.3.2.2 Controlling the V_{NEG} Transition Time

The transition time (t_{set}) is the time required to move V_{NEG} from one voltage level to the next. Users can control the transition time by connecting a capacitor between the CT pin and ground. When the CT pin is left open or is connected to ground, the transition time is as short as possible. When a capacitor is connected to the CT pin, the transition time is determined by the time constant (τ) of the external capacitor ($C_{(CT)}$) and the internal resistance of the CT pin ($R_{(CT)}$). The output voltage V_{NEG} reaches 70% of its programmed value after 1τ .

An example is given below for the case when using 100 nF for $C_{(CT)}$.

$$\tau \approx t_{set(70\%)} = R_{(CT)} \times C_{(CT)} = 300 \text{ k}\Omega \times 100 \text{ nF} = 30 \text{ ms} \quad (1)$$

The output voltage V_{NEG} reaches its programmed value after approximately 3τ .

The external capacitor connected to the CT pin has no effect on the first programming of V_{NEG} , when the inverting buck-boost converter ramps its output to the default voltage as fast as possible. [Figure 7](#) shows the detail of programming of the V_{NEG} transition time with the CT pin during start-up.

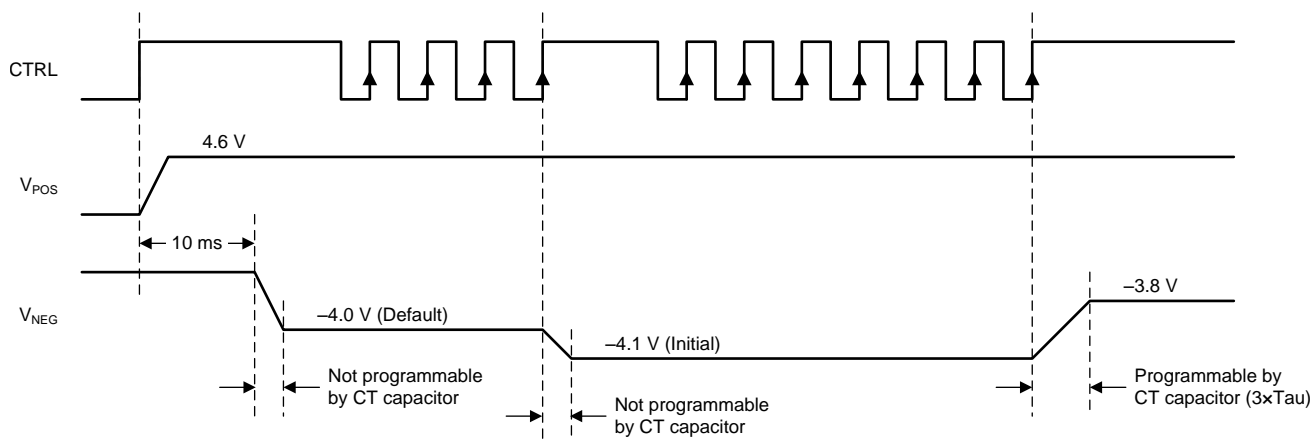

Figure 7. Programming the Transition Time of V_{NEG}

8.3.3 Soft-Start and Start-Up Sequence

The TPS65631 features a soft-start function to limit inrush current. When the device is enabled by a high-level signal applied to the CTRL pin, the boost converter starts switching with a reduced switch current limit. Ten milliseconds after the CTRL pin goes high, the inverting buck-boost converter starts with a default value of -4 V . A typical start-up sequence is shown in [Figure 8](#).

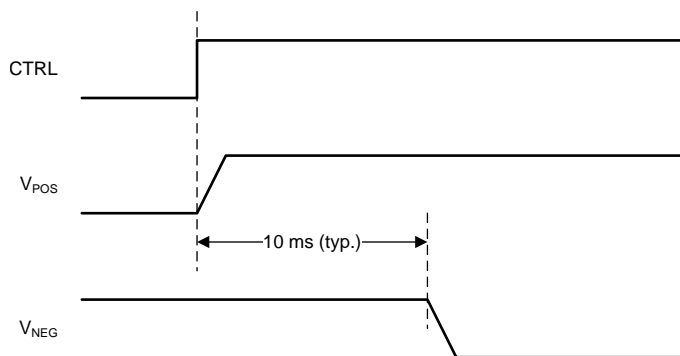

Figure 8. Typical Start-Up Sequence

8.3.4 Enable (CTRL)

The CTRL pin serves two functions. One is to enable and disable the device, and the other is to program the output voltage (V_{NEG}) of the inverting buck-boost converter (see [Programming \$V_{NEG}\$](#)). If the digital interface is not required, the CTRL pin can be used as a standard enable pin for the device, which will come up with its default value on V_{NEG} of -4 V. When CTRL is pulled high, the device is enabled. The device is shut down with CTRL low.

8.3.5 Undervoltage Lockout

The TPS65631 features an undervoltage lockout function that disables the device when the input supply voltage is too low for normal operation.

8.3.6 Short Circuit Protection

The TPS65631 is protected against short-circuits of V_{POS} and V_{NEG} to ground and to each other.

8.3.6.1 Short-Circuits During Normal Operation

During normal operation an error condition is detected if V_{POS} falls below 4.1 V for more than 3 ms or V_{NEG} is pulled above the programmed nominal output by 500 mV for longer than 3 ms. In either case the device enters shutdown mode: the converters are disabled and their outputs are disconnected from the input. To resume normal operation either cycle the input supply voltage or toggle the CTRL pin low and then high again.

8.3.6.2 Short-Circuits During Start-Up

During start-up an error condition is detected if:

- V_{POS} is not in regulation 10 ms after a high-level is applied to the CTRL pin.
- V_{NEG} is higher than threshold level 10 ms after a high-level is applied to the CTRL pin.
- V_{NEG} is not in regulation 20 ms after a high-level is applied to the CTRL pin.

To resume normal operation either cycle the input supply voltage or toggle the CTRL pin low and then high again.

8.3.7 Output Discharge During Shutdown

The TPS65631 actively discharges its outputs during shutdown. [Figure 9](#) shows the output discharge control.

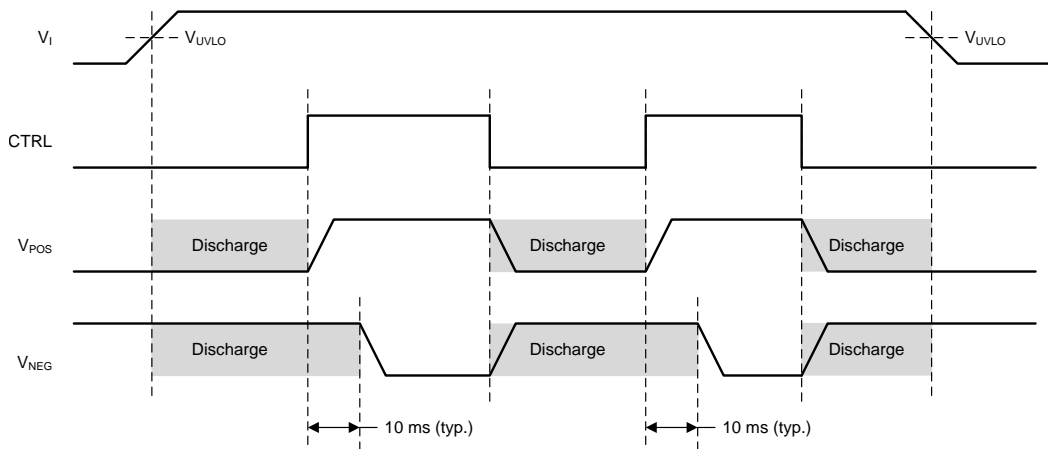

Figure 9. Active Discharge of V_{POS} and V_{NEG} During Shutdown

8.3.8 Thermal Shutdown

The TPS65631 enters thermal shutdown mode if its junction temperature exceeds 145°C (typical). During thermal shutdown mode none of the device functions are available. To resume normal operation, either cycle the input supply voltage or toggle the CTRL pin low and then high again.

8.4 Device Functional Modes

8.4.1 Operation with $V_I < 2.9\text{ V}$

The recommended minimum input supply voltage for full performance is 2.9 V. The device continues to operate with input supply voltages below 2.9 V; however, full performance is not guaranteed. The device does not operate with input supply voltages below the UVLO threshold.

8.4.2 Operation with $V_I \approx V_{POS}$ (Diode Mode)

The TPS65631 features a "diode" mode that enables it to regulate its output voltage even when the input supply voltage is close to V_{POS} (that is, too high for normal boost operation). When operating in diode mode the converter's high-side switch stops switching and its body diode is used as the rectifier. Boost converter efficiency is reduced when operating in diode mode. At low output currents ($\approx 2\text{ mA}$ and below), the boost converter automatically transitions from pulse-width modulation to pulse-skip mode. This ensures that V_{POS} stays in regulation but increases the output voltage ripple on V_{POS} .

8.4.3 Operation with CTRL

When a low-level signal is applied to the CTRL pin the device is disabled and switching is inhibited. When the input supply voltage is above the UVLO threshold and a high-level signal is applied to the CTRL pin the device is enabled and its start-up sequence begins.

9 Applications and Implementation

9.1 Application Information

Figure 10 shows a typical application circuit suitable for supplying AMOLED displays in smartphone applications. The circuit is designed to operate from a single-cell Li-Ion battery and generates a positive output voltage V_{POS} of 4.6 V and a negative output voltage of -4 V . Both outputs are capable of supplying up to 300 mA of output current.

9.2 Typical Application

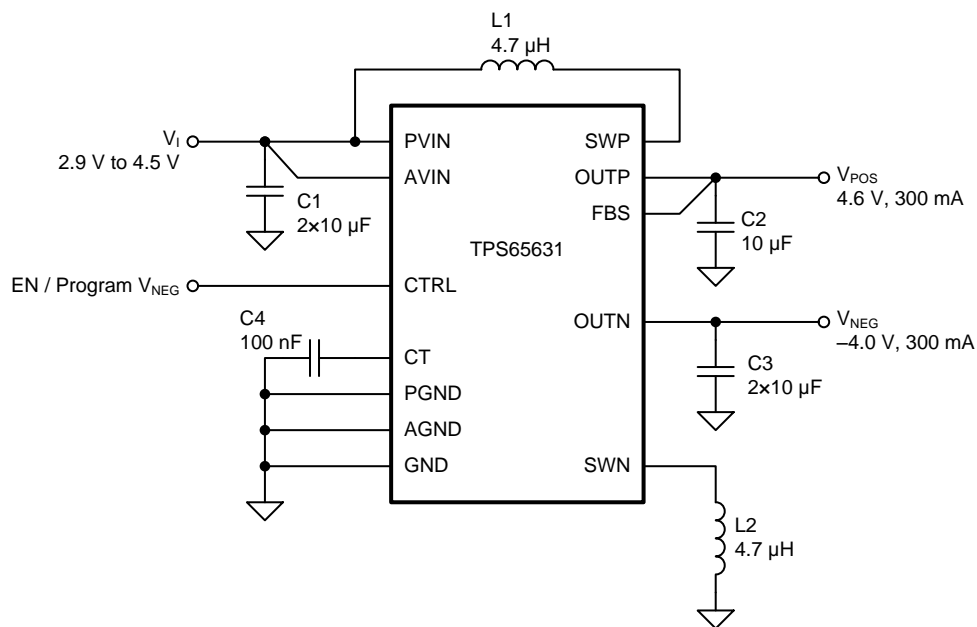

Figure 10. Typical Application Schematic

Typical Application (continued)

9.2.1 Design Requirements

For this design example, use the following input parameters.

Table 2. Design Parameters

DESIGN PARAMETER	EXAMPLE
Input voltage range	2.9 V to 4.5 V
Output voltage	$V_{POS} = 4.6V$, $V_{NEG} = -4 V$
Switching frequency	1.7 MHz

9.2.2 Detailed Design Procedure

In order to maximize performance, the TPS65631 has been optimized for use with a relatively narrow range of component values, and customers are strongly recommended to use the application circuit shown in [Figure 10](#) with the components listed in [Table 3](#) and [Table 4](#).

9.2.2.1 Inductor Selection

The boost converter and inverting buck-boost converter have been optimized for use with 4.7 μ H inductors, and it is recommended that this value be used in all applications. Customers using other values of inductor are strongly recommended to characterize circuit performance on a case-by-case basis.

Table 3. Inductor Selection

PARAMETER	VALUE	MANUFACTURER	PART NUMBER
L1, L2	4.7 μ H	Coilmaster	MMPP252012-4R7N
		Toko	1239AS-H-4R7M
		ABCO	LPP252012-4R7N
		Coilcraft	XFL4020-4R7ML

9.2.2.2 Capacitor Selection

The recommended capacitor values are shown in [Table 4](#). Applications using less than the recommended capacitance (e.g. to save PCB area) may experience increased voltage ripple. In general, the lower the output power, the lower the necessary capacitance.

Table 4. Capacitor Selection

PARAMETER	VALUE	MANUFACTURER	PART NUMBER
C1	$2 \times 10 \mu F$	Murata	GRM21BR71A106KE51
C2	10 μF	Murata	GRM21BR71A106KE51
C3	$2 \times 10 \mu F$	Murata	GRM21BR71A106KE51
C4	100 nF	Murata	GRM21BR71E104KA01

9.2.2.3 Stability

Applications using component values that differ significantly from those recommended in [Table 3](#) and [Table 4](#) should be checked for stability over the full range of operating conditions.

9.2.3 Application Curves

The performance shown in the following graphs was obtained using the circuit shown in [Figure 10](#) and the external components shown in [Table 3](#) and [Table 4](#). The output voltage settings for these measurements were $V_{POS} = 4.6\text{ V}$ and $V_{NEG} = -4\text{ V}$.

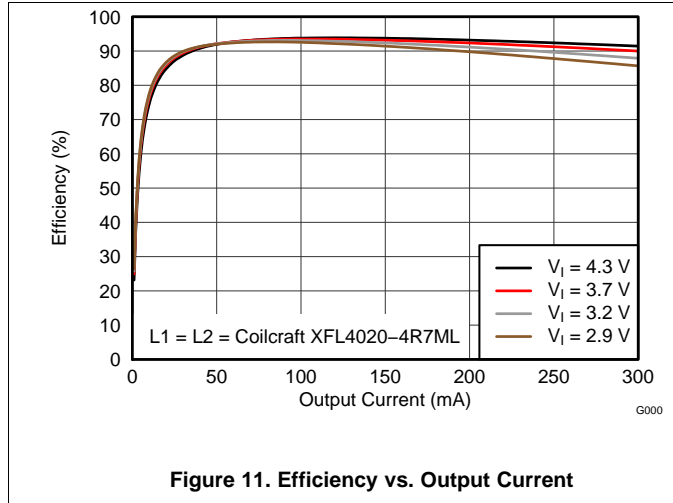

Figure 11. Efficiency vs. Output Current

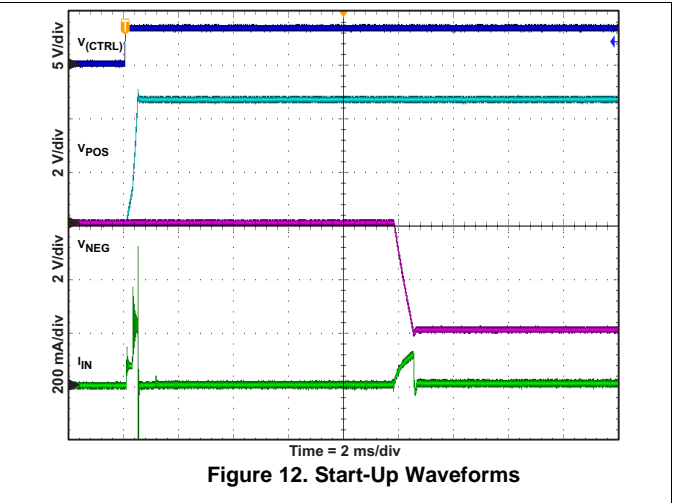

Figure 12. Start-Up Waveforms

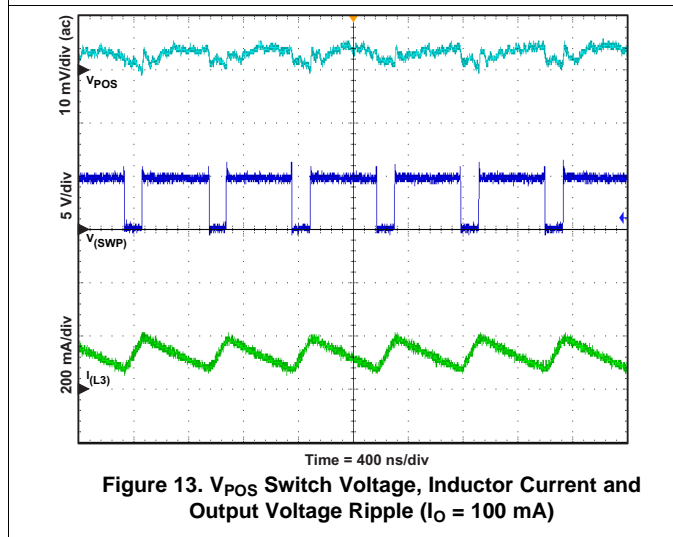

Figure 13. V_{POS} Switch Voltage, Inductor Current and Output Voltage Ripple ($I_O = 100\text{ mA}$)

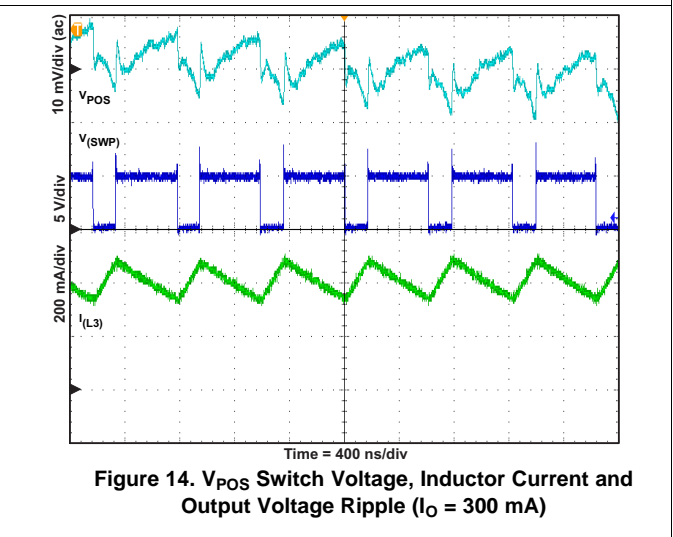

Figure 14. V_{POS} Switch Voltage, Inductor Current and Output Voltage Ripple ($I_O = 300\text{ mA}$)

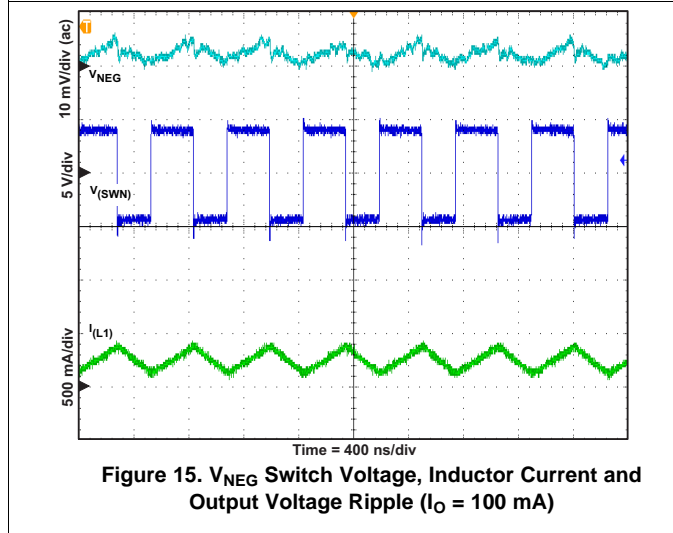

Figure 15. V_{NEG} Switch Voltage, Inductor Current and Output Voltage Ripple ($I_O = 100\text{ mA}$)

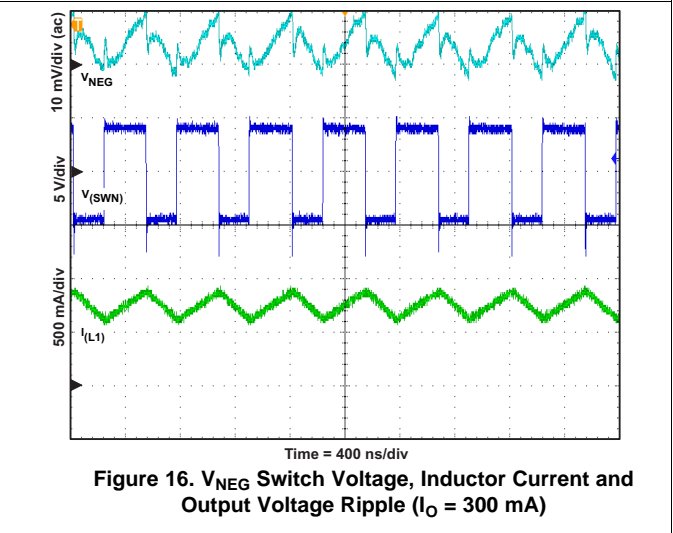

Figure 16. V_{NEG} Switch Voltage, Inductor Current and Output Voltage Ripple ($I_O = 300\text{ mA}$)

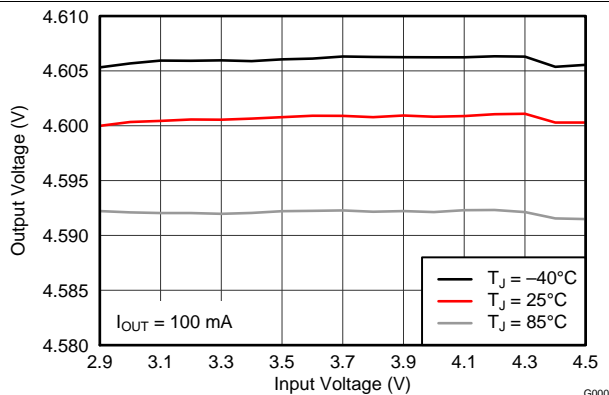

Figure 17. Boost Converter Line Regulation

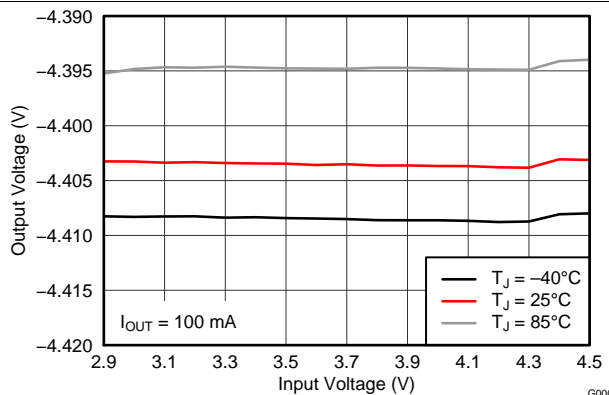

Figure 18. Inverting Buck-Boost Converter Line Regulation

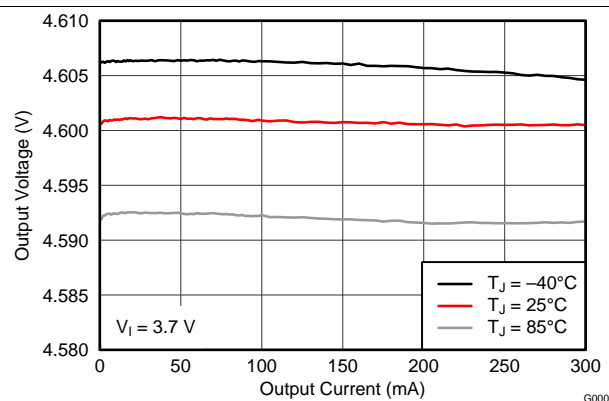

Figure 19. Boost Converter Load Regulation

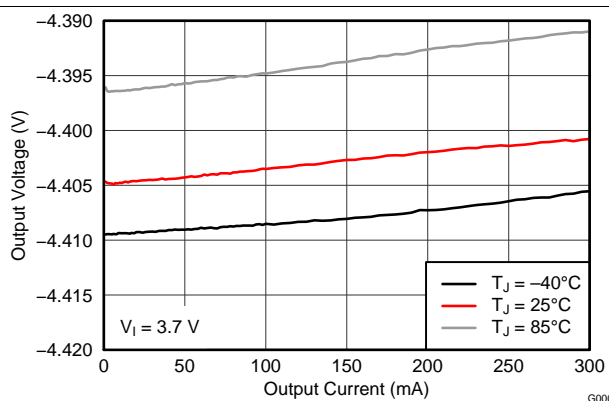

Figure 20. Inverting Buck-Boost Converter Load Regulation

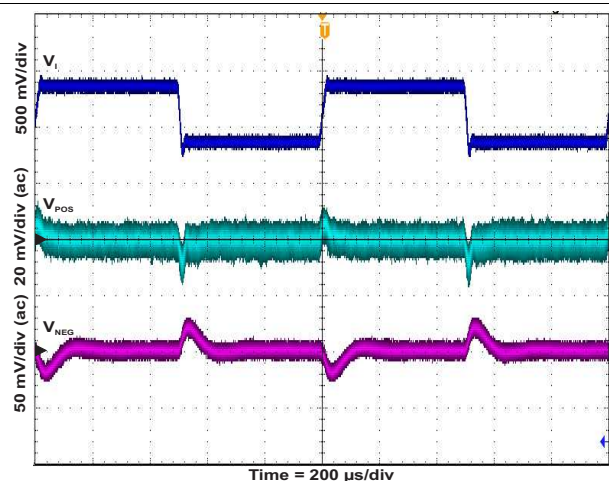

Figure 21. Line Transient Response

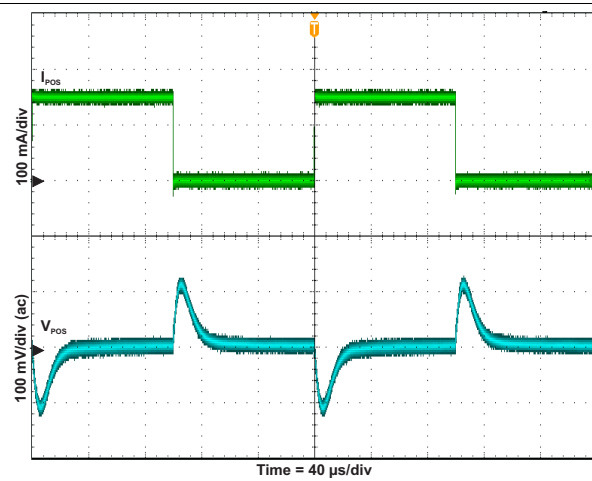
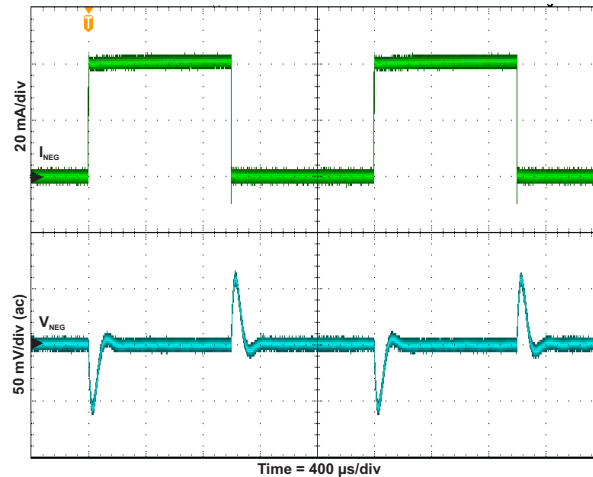

Figure 22. Boost Converter Load Transient Response

Figure 23. Inverting Buck-Boost Converter Load Transient Response

10 Power Supply Recommendations

The TPS65631 is designed to operate from an input voltage supply range between 2.9 V and 4.5 V. If the input supply is located more than a few centimeters from the TPS65631 additional bulk capacitance may be required. The 2x10 μ F shown in the schematics in this data sheet are a typical choice for this function.

11 Layout

11.1 Layout Guidelines

No PCB layout is perfect, and compromises are always necessary. However, following the basic principles listed below (in order of importance) should go a long way to achieving good performance:

- Route switching currents on the top layer using short, wide traces. Do not route these signals through vias, which have relatively high parasitic inductance and resistance.
- Place C1 as close as possible to pin 12.
- Place C2 as close as possible to pin 3.
- Place C3 as close as possible to pin 9.
- Place L1 as close as possible to pin 1.
- Place L2 as close as possible to pin 10.
- Use the thermal pad to join GND, AGND and PGND.
- Connect the FBS pin directly to the positive pin of C2, that is, keep this connection separate from the connection between OUTP and C2.
- Use a copper pour on layer 2 as a thermal spreader and connect the thermal pad to it using a number of thermal vias.

Figure 24 illustrates how a PCB layout following the above principles may be realized in practice.

11.2 Layout Example

Figure 24 shows the above principles implemented for the circuit of Figure 10.

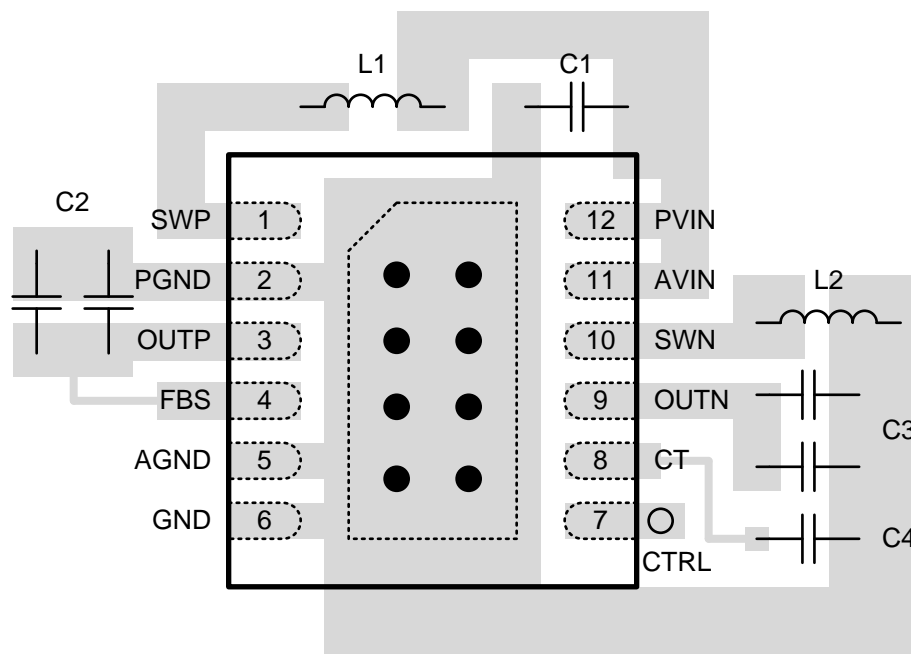

- Via to signal layer on internal or bottom layer.
- Thermal via to copper pour on internal or bottom layer.

Figure 24. PCB Layout Example

12 Device and Documentation Support

12.1 Device Support

12.1.1 Third-Party Products Disclaimer

TI'S PUBLICATION OF INFORMATION REGARDING THIRD-PARTY PRODUCTS OR SERVICES DOES NOT CONSTITUTE AN ENDORSEMENT REGARDING THE SUITABILITY OF SUCH PRODUCTS OR SERVICES OR A WARRANTY, REPRESENTATION OR ENDORSEMENT OF SUCH PRODUCTS OR SERVICES, EITHER ALONE OR IN COMBINATION WITH ANY TI PRODUCT OR SERVICE.

12.2 Trademarks

All trademarks are the property of their respective owners.

12.3 Electrostatic Discharge Caution



These devices have limited built-in ESD protection. The leads should be shorted together or the device placed in conductive foam during storage or handling to prevent electrostatic damage to the MOS gates.

12.4 Glossary

[SLYZ022](#) — *TI Glossary*.

This glossary lists and explains terms, acronyms and definitions.

13 Mechanical, Packaging, and Orderable Information

The following pages include mechanical packaging and orderable information. This information is the most current data available for the designated devices. This data is subject to change without notice and revision of this document. For browser-based versions of this data sheet, refer to the left-hand navigation.

PACKAGING INFORMATION

Orderable Device	Status (1)	Package Type	Package Drawing	Pins	Package Qty	Eco Plan (2)	Lead/Ball Finish (6)	MSL Peak Temp (3)	Op Temp (°C)	Device Marking (4/5)	Samples
TPS65631DPDR	ACTIVE	WSON	DPD	12	3000	Green (RoHS & no Sb/Br)	CU NIPDAU	Level-2-260C-1 YEAR	-40 to 85	SDS	Samples

(1) The marketing status values are defined as follows:

ACTIVE: Product device recommended for new designs.

LIFEBUY: TI has announced that the device will be discontinued, and a lifetime-buy period is in effect.

NRND: Not recommended for new designs. Device is in production to support existing customers, but TI does not recommend using this part in a new design.

PREVIEW: Device has been announced but is not in production. Samples may or may not be available.

OBSELETE: TI has discontinued the production of the device.

(2) Eco Plan - The planned eco-friendly classification: Pb-Free (RoHS), Pb-Free (RoHS Exempt), or Green (RoHS & no Sb/Br) - please check <http://www.ti.com/productcontent> for the latest availability information and additional product content details.

TBD: The Pb-Free/Green conversion plan has not been defined.

Pb-Free (RoHS): TI's terms "Lead-Free" or "Pb-Free" mean semiconductor products that are compatible with the current RoHS requirements for all 6 substances, including the requirement that lead not exceed 0.1% by weight in homogeneous materials. Where designed to be soldered at high temperatures, TI Pb-Free products are suitable for use in specified lead-free processes.

Pb-Free (RoHS Exempt): This component has a RoHS exemption for either 1) lead-based flip-chip solder bumps used between the die and package, or 2) lead-based die adhesive used between the die and leadframe. The component is otherwise considered Pb-Free (RoHS compatible) as defined above.

Green (RoHS & no Sb/Br): TI defines "Green" to mean Pb-Free (RoHS compatible), and free of Bromine (Br) and Antimony (Sb) based flame retardants (Br or Sb do not exceed 0.1% by weight in homogeneous material)

(3) MSL, Peak Temp. - The Moisture Sensitivity Level rating according to the JEDEC industry standard classifications, and peak solder temperature.

(4) There may be additional marking, which relates to the logo, the lot trace code information, or the environmental category on the device.

(5) Multiple Device Markings will be inside parentheses. Only one Device Marking contained in parentheses and separated by a "-" will appear on a device. If a line is indented then it is a continuation of the previous line and the two combined represent the entire Device Marking for that device.

(6) Lead/Ball Finish - Orderable Devices may have multiple material finish options. Finish options are separated by a vertical ruled line. Lead/Ball Finish values may wrap to two lines if the finish value exceeds the maximum column width.

Important Information and Disclaimer:The information provided on this page represents TI's knowledge and belief as of the date that it is provided. TI bases its knowledge and belief on information provided by third parties, and makes no representation or warranty as to the accuracy of such information. Efforts are underway to better integrate information from third parties. TI has taken and continues to take reasonable steps to provide representative and accurate information but may not have conducted destructive testing or chemical analysis on incoming materials and chemicals. TI and TI suppliers consider certain information to be proprietary, and thus CAS numbers and other limited information may not be available for release.

In no event shall TI's liability arising out of such information exceed the total purchase price of the TI part(s) at issue in this document sold by TI to Customer on an annual basis.

TAPE AND REEL INFORMATION



QUADRANT ASSIGNMENTS FOR PIN 1 ORIENTATION IN TAPE



*All dimensions are nominal

Device	Package Type	Package Drawing	Pins	SPQ	Reel Diameter (mm)	Reel Width W1 (mm)	A0 (mm)	B0 (mm)	K0 (mm)	P1 (mm)	W (mm)	Pin1 Quadrant
TPS65631DPDR	WSO	DPD	12	3000	330.0	12.4	3.3	3.3	1.1	8.0	12.0	Q2

TAPE AND REEL BOX DIMENSIONS

*All dimensions are nominal

Device	Package Type	Package Drawing	Pins	SPQ	Length (mm)	Width (mm)	Height (mm)
TPS65631DPDR	WSON	DPD	12	3000	367.0	367.0	35.0

DPD (S-PWSON-N12)

PLASTIC SMALL OUTLINE NO-LEAD

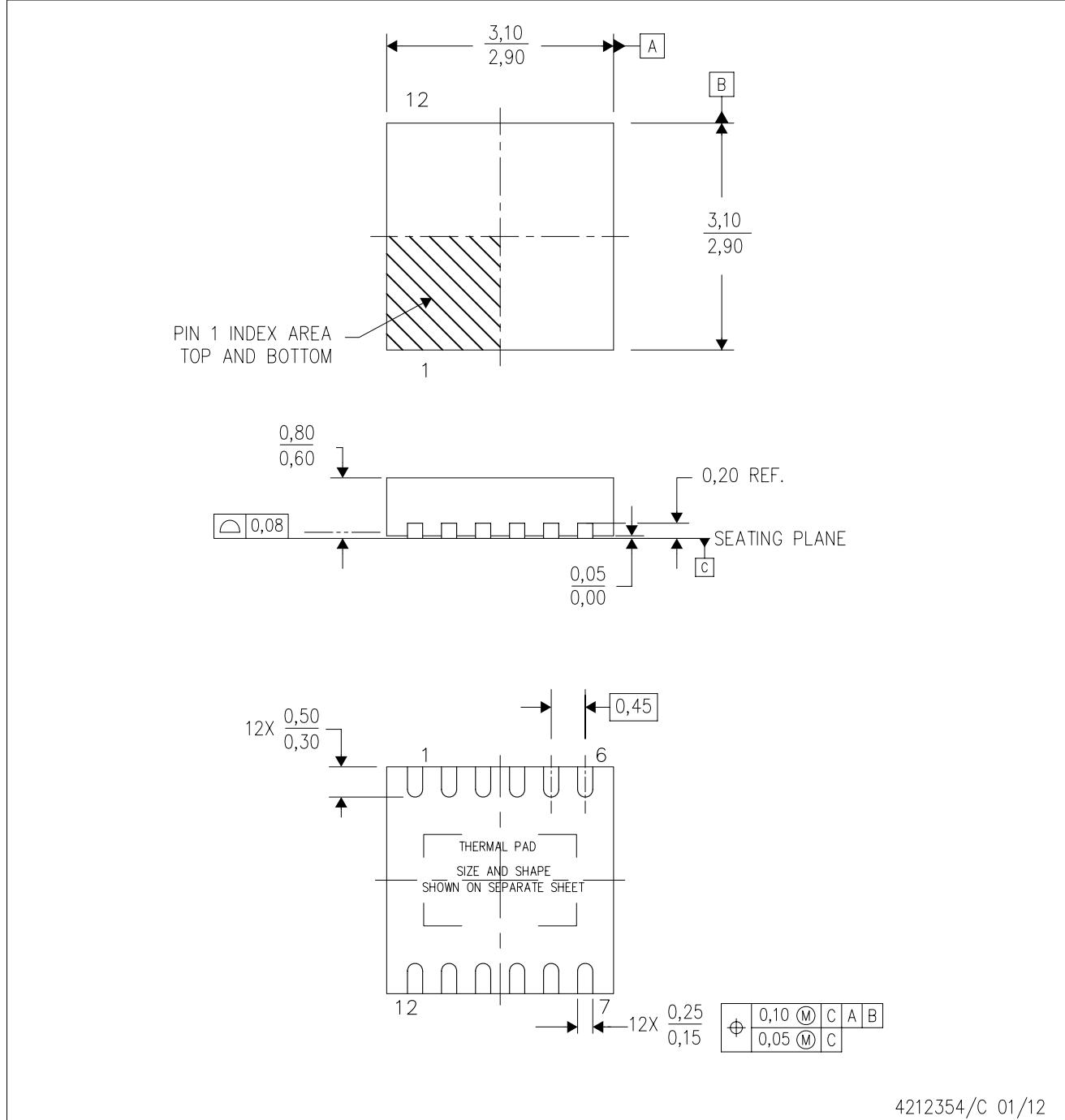

4212354/C 01/12

- NOTES:
- All linear dimensions are in millimeters. Dimensioning and tolerancing per ASME Y14.5M-1994.
 - This drawing is subject to change without notice.
 - Small Outline No-Lead (SON) package configuration.
 - The package thermal pad must be soldered to the board for thermal and mechanical performance, if present.
 - See the additional figure in the Product Data Sheet for details regarding the exposed thermal pad features and dimensions, if present.

THERMAL PAD MECHANICAL DATA

DPD (S-PUSON-N12)

PLASTIC SMALL OUTLINE NO-LEAD

THERMAL INFORMATION

This package incorporates an exposed thermal pad that is designed to be attached directly to an external heatsink. The thermal pad must be soldered directly to the printed circuit board (PCB). After soldering, the PCB can be used as a heatsink. In addition, through the use of thermal vias, the thermal pad can be attached directly to the appropriate copper plane shown in the electrical schematic for the device, or alternatively, can be attached to a special heatsink structure designed into the PCB. This design optimizes the heat transfer from the integrated circuit (IC).

For information on the Quad Flatpack No-Lead (QFN) package and its advantages, refer to Application Report, QFN/SON PCB Attachment, Texas Instruments Literature No. SLUA271. This document is available at www.ti.com.

The exposed thermal pad dimensions for this package are shown in the following illustration.

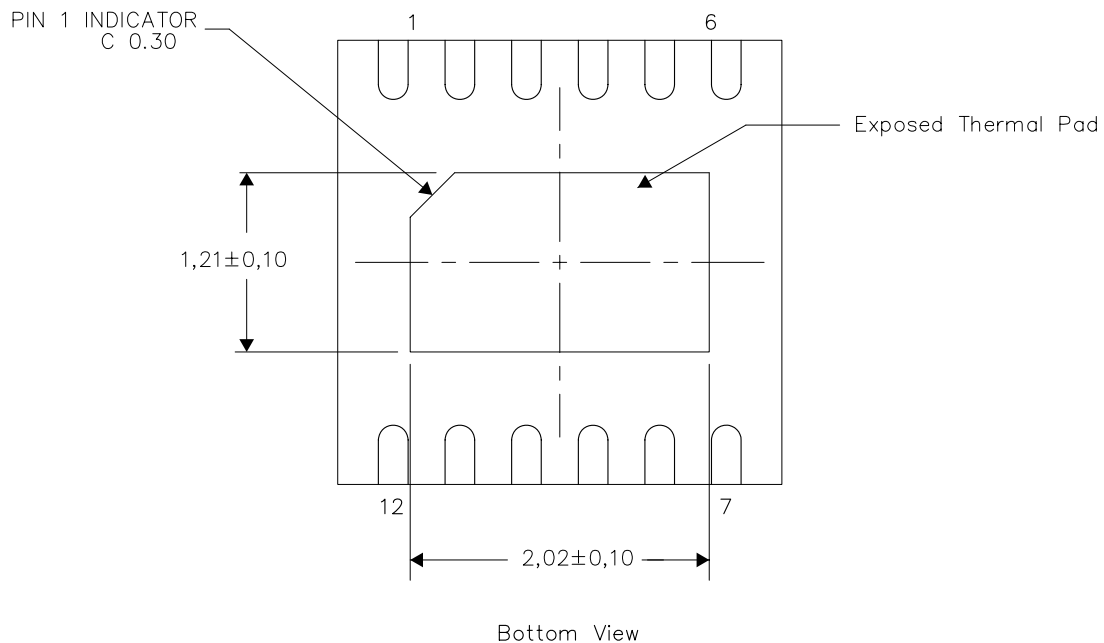

Exposed Thermal Pad Dimensions

4212468/A 02/12

NOTE: All linear dimensions are in millimeters

IMPORTANT NOTICE AND DISCLAIMER

TI PROVIDES TECHNICAL AND RELIABILITY DATA (INCLUDING DATASHEETS), DESIGN RESOURCES (INCLUDING REFERENCE DESIGNS), APPLICATION OR OTHER DESIGN ADVICE, WEB TOOLS, SAFETY INFORMATION, AND OTHER RESOURCES "AS IS" AND WITH ALL FAULTS, AND DISCLAIMS ALL WARRANTIES, EXPRESS AND IMPLIED, INCLUDING WITHOUT LIMITATION ANY IMPLIED WARRANTIES OF MERCHANTABILITY, FITNESS FOR A PARTICULAR PURPOSE OR NON-INFRINGEMENT OF THIRD PARTY INTELLECTUAL PROPERTY RIGHTS.

These resources are intended for skilled developers designing with TI products. You are solely responsible for (1) selecting the appropriate TI products for your application, (2) designing, validating and testing your application, and (3) ensuring your application meets applicable standards, and any other safety, security, or other requirements. These resources are subject to change without notice. TI grants you permission to use these resources only for development of an application that uses the TI products described in the resource. Other reproduction and display of these resources is prohibited. No license is granted to any other TI intellectual property right or to any third party intellectual property right. TI disclaims responsibility for, and you will fully indemnify TI and its representatives against, any claims, damages, costs, losses, and liabilities arising out of your use of these resources.

TI's products are provided subject to TI's Terms of Sale (www.ti.com/legal/termsofsale.html) or other applicable terms available either on ti.com or provided in conjunction with such TI products. TI's provision of these resources does not expand or otherwise alter TI's applicable warranties or warranty disclaimers for TI products.

Mailing Address: Texas Instruments, Post Office Box 655303, Dallas, Texas 75265
Copyright © 2019, Texas Instruments Incorporated

Looking for pricing, stock, or lifecycle information?

Click below to explore more details on WIN SOURCE:

 [View TPS65631DPDR](#) on WIN SOURCE

 [Texas Instruments](#) Information

Optimize Your Supply Chain with WIN SOURCE Solutions

-  Global Sourcing Solution
-  Obsolete Management
-  Cost Control Management
-  Shortage Management
-  Alternative Solution
-  Excess Inventory Management