



**THE DATASHEET OF
ADS130E08IPAGR**





Low-Cost, 8-Channel, Integrated Analog Front-End for Metering Applications

Check for Samples: [ADS130E08](#)

FEATURES

- **Eight Differential Current and Voltage Inputs**
- **Eight Low-Noise PGAs and Eight High-Resolution ADCs**
- **Exceeds Class 1.0 Performance**
- **CMRR: –110 dB**
- **Crosstalk: –105 dB**
- **THD: –108 dB**
- **Power: 750 μ W/Channel**
- **Data Rates: 8 kSPS**
- **Programmable Gains (1, 2, and 8)**
- **DC Coupling:**
 - **Dual Supplies: +3 V to +5 V or +1.8 V to +3.6 V**
 - **Bipolar Supply: \pm 2.5 V**
- **Built-In Test Signals**
- **Fault Detection Comparators**
- **Four GPIO Pins**
- **Internal and External Reference**
- **Flexible Power-Down: STBY Mode**
- **SPI™ Data Interface**
- **Package: TQFP-64 (PAG)**
- **Operating Temperature Range: –40°C to +105°C**

APPLICATIONS

- **Industrial Power Applications:**
 - **Three-Phase Metering**
 - **Industrial Applications**

DESCRIPTION

The ADS130E08 is a multi-channel, simultaneous sampling, 16-bit, delta-sigma ($\Delta\Sigma$) analog-to-digital converter (ADC) with a built-in programmable gain amplifier (PGA), internal reference, and an external oscillator interface.

The device incorporates commonly-required features in industrial metering applications. With high levels of integration and exceptional performance, the ADS130E08 enables the creation of scalable industrial power systems at significantly reduced size, power, and low overall cost.

The ADS130E08 has a flexible input multiplexer per channel that can be independently connected to the internally-generated signals for test, temperature, and fault detection. The ADS130E08 operates at a data rate of 8 kSPS. Fault detection can be implemented internal to the device using the integrated comparators with digital-to-analog converter (DAC)-controlled trigger levels.

Multiple devices can be cascaded in high channel count systems in a daisy-chain configuration. These complete analog front-end (AFE) solutions are packaged in a TQFP-64 package and specified over the industrial temperature range of –40°C to +105°C.

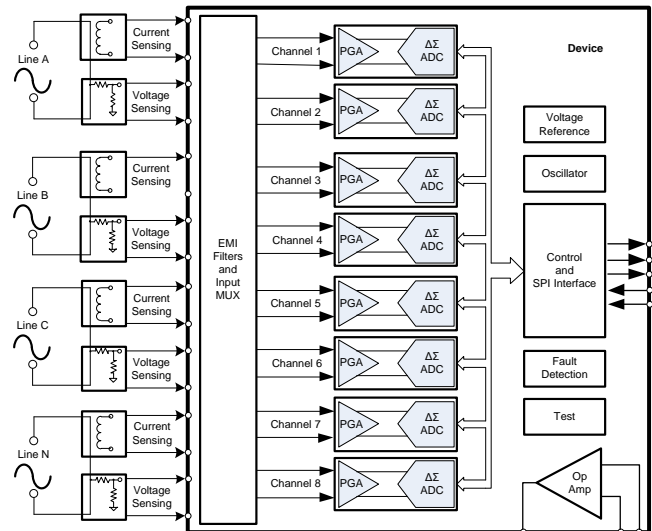

Please be aware that an important notice concerning availability, standard warranty, and use in critical applications of Texas Instruments semiconductor products and disclaimers thereto appears at the end of this data sheet.

SPI is a trademark of Motorola.

All other trademarks are the property of their respective owners.



This integrated circuit can be damaged by ESD. Texas Instruments recommends that all integrated circuits be handled with appropriate precautions. Failure to observe proper handling and installation procedures can cause damage.

ESD damage can range from subtle performance degradation to complete device failure. Precision integrated circuits may be more susceptible to damage because very small parametric changes could cause the device not to meet its published specifications.

FAMILY AND ORDERING INFORMATION⁽¹⁾

PRODUCT	PACKAGE OPTION	NUMBER OF CHANNELS	ACCURACY	MAXIMUM SAMPLE RATE (kSPS)	OPERATING TEMPERATURE RANGE
ADS130E08	TQFP-64	8	Class 1.0	8	–40°C to +105°C
ADS131E04	TQFP-64	4	Class 0.1	64	–40°C to +105°C
ADS131E06	TQFP-64	6	Class 0.1	64	–40°C to +105°C
ADS131E08	TQFP-64	8	Class 0.1	64	–40°C to +105°C

(1) For the most current package and ordering information, see the Package Option Addendum at the end of this document, or visit the device product folder at www.ti.com.

ABSOLUTE MAXIMUM RATINGS⁽¹⁾

Over operating free-air temperature range, unless otherwise noted.

	VALUE	UNIT
AVDD to AVSS	–0.3 to +5.5	V
DVDD to DGND	–0.3 to +3.9	V
AVSS to DGND	–2.75 to +0.2	V
V _{REF} input to AVSS	AVSS – 0.3 to AVDD + 0.3	V
Analog input to AVSS	AVSS – 0.3 to AVDD + 0.3	V
Digital input voltage to DVDD	–0.3 to DVDD + 0.3	V
Digital output voltage to DGND	–0.3 to DVDD + 0.3	V
Input current	Momentary	100
	Continuous	10
Temperature	Operating, T _A	–40 to +105
	Storage, T _{stg}	–60 to +150
	Maximum junction, T _J	+150
Electrostatic discharge (ESD) ratings	Human body model (HBM) JEDEC standard 22, test method A114-C.01, all pins	±1000
	Charged device model (CDM) JEDEC standard 22, test method C101, all pins	±500

(1) Stresses above these ratings may cause permanent damage. Exposure to absolute maximum conditions for extended periods may degrade device reliability. These are stress ratings only, and functional operation of the device at these or any other conditions beyond those specified is not implied.

ELECTRICAL CHARACTERISTICS

Minimum and maximum specifications apply from -40°C to $+105^{\circ}\text{C}$. Typical specifications are at $+25^{\circ}\text{C}$. All specifications are at $\text{DVDD} = 1.8\text{ V}$, $\text{AVDD} = 3\text{ V}$, $\text{AVSS} = 0\text{ V}$, $V_{\text{REF}} = 2.4\text{ V}$, external $f_{\text{CLK}} = 2.048\text{ MHz}$, data rate = 8 kSPS, and gain = 1, unless otherwise noted.

PARAMETER	TEST CONDITIONS	ADS130E08			UNIT
		MIN	TYP	MAX	
ANALOG INPUTS					
Full-scale differential input voltage (AINP – AINN)		$\pm V_{\text{REF}} / \text{gain}$			V
Input common-mode range		See the Input Common-Mode Range subsection of the PGA Settings and Input Range section			
C_i Input capacitance		20			pF
I_{IB} Input bias current		2			nA
DC input impedance		500			M Ω
PGA PERFORMANCE					
Gain settings		1, 2, 8			
BW Bandwidth		See Table 1			
ADC PERFORMANCE					
Resolution	No missing codes	16			Bits
DR Data rate	$f_{\text{CLK}} = 2.048\text{ MHz}$	8			kSPS
CHANNEL PERFORMANCE (DC Performance)					
Dynamic range	$G = 1$	86	89		dB
	$G = 2$ and 8		89		dB
INL Integral nonlinearity	Full-scale with gain = 1, best fit	3			ppm
E_o Offset error		± 350			μV
Offset error drift		0.6			$\mu\text{V}/^{\circ}\text{C}$
E_G Gain error	Excluding voltage reference error	± 0.1			% of FS
Gain drift	Excluding voltage reference drift	3			ppm/ $^{\circ}\text{C}$
Gain match between channels		0.2			% of FS
CHANNEL PERFORMANCE (AC Performance)					
CMRR Common-mode rejection ratio	$f_{\text{CM}} = 50\text{ Hz}$ and $60\text{ Hz}^{(1)}$	-110			dB
PSRR Power-supply rejection ratio	$f_{\text{PS}} = 50\text{ Hz}$ and 60 Hz	80			dB
Crosstalk	$f_{\text{IN}} = 50\text{ Hz}$ and 60 Hz	-105			dB
Accuracy	1:3000 dynamic range with a 1-second measurement ($V_{\text{RMS}} / I_{\text{RMS}}$)	0.5			%
SNR Signal-to-noise ratio	$f_{\text{IN}} = 10\text{-Hz}$ input, -0.5 dBFS	89			dB
THD Total harmonic distortion	10 Hz, -0.5 dBFS	-108			dB
OPEN-CIRCUIT DETECT AND ALARM					
Comparator threshold accuracy		± 30			mV
EXTERNAL REFERENCE					
$V_{\text{I(ref)}}$ Reference input voltage	$\text{AVDD} = 3\text{ V}$, $V_{\text{REF}} = (V_{\text{REFP}} - V_{\text{REFN}})$	2.5			V
	$\text{AVDD} = 5\text{ V}$, $V_{\text{REF}} = (V_{\text{REFP}} - V_{\text{REFN}})$	4			V
VREFN Negative input		AVSS			V
VREFP Positive input		AVSS + 2.5			V
Input impedance		10			k Ω

(1) CMRR is measured with a common-mode signal of $(\text{AVSS} + 0.3\text{ V})$ to $(\text{AVDD} - 0.3\text{ V})$. The values indicated are the minimum of the eight channels.

ELECTRICAL CHARACTERISTICS (continued)

Minimum and maximum specifications apply from -40°C to $+105^{\circ}\text{C}$. Typical specifications are at $+25^{\circ}\text{C}$. All specifications are at $\text{DVDD} = 1.8\text{ V}$, $\text{AVDD} = 3\text{ V}$, $\text{AVSS} = 0\text{ V}$, $V_{\text{REF}} = 2.4\text{ V}$, external $f_{\text{CLK}} = 2.048\text{ MHz}$, data rate = 8 kSPS, and gain = 1, unless otherwise noted.

PARAMETER		TEST CONDITIONS	ADS130E08			UNIT
			MIN	TYP	MAX	
OPERATIONAL AMPLIFIER						
	Integrated noise	0.1 Hz to 100 Hz		7		μV_{RMS}
	Noise density	2 kHz		120		$\text{nV}/\sqrt{\text{Hz}}$
GBP	Gain bandwidth product	50 k Ω 10-pF load		100		kHz
SR	Slew rate	50 k Ω 10-pF load		0.25		$\text{V}/\mu\text{s}$
	Load current			50		μA
THD	Total harmonic distortion	$f_{\text{IN}} = 100\text{ Hz}$		70		dB
CMIR	Common-mode input range		$\text{AVSS} + 0.7$		$\text{AVSS} - 0.3$	V
	Quiescent power consumption			20		μA
INTERNAL REFERENCE						
V_{O}	Output voltage	CONFIG3.VREF_4V = 0		2.4		V
		CONFIG3.VREF_4V = 1		4		V
	V_{REF} accuracy			± 0.2		%
	Drift	-40°C to $+105^{\circ}\text{C}$		45		$\text{ppm}/^{\circ}\text{C}$
	Start-up time	Settled to 0.2%		150		ms
SYSTEM MONITORS						
	Analog supply reading error			2		%
	Digital supply reading error			2		%
	Device wake up	From power-up to $\overline{\text{DRDY}}$ low		150		ms
		STANDBY mode		125		μs
Temperature sensor reading	Voltage	$T_{\text{A}} = +25^{\circ}\text{C}$		145		mV
	Coefficient			490		$\mu\text{V}/^{\circ}\text{C}$
TEST SIGNAL						
Signal frequency		See Register Map section for settings		$f_{\text{CLK}} / 2^{21}$		Hz
				$f_{\text{CLK}} / 2^{20}$		Hz
Signal voltage		See Register Map section for settings		± 1		mV
				± 2		mV
Accuracy				± 2		%
CLOCK						
Internal oscillator clock frequency		Nominal frequency		2.048		MHz
		$T_{\text{A}} = +25^{\circ}\text{C}$			± 0.5	%
		$-40^{\circ}\text{C} \leq T_{\text{A}} \leq +105^{\circ}\text{C}$			± 2.5	%
	Internal oscillator start-up time			20		μs
	Internal oscillator power consumption			120		μW
	External clock input frequency	CLKSEL pin = 0	0.7	2.048	2.25	MHz
DIGITAL INPUT AND OUTPUT (DVDD = 1.8 V to 3.6 V)						
V_{IH}	Logic level, input voltage	High		0.8 DVDD	DVDD + 0.1	V
V_{IL}		Low		-0.1	0.2 DVDD	V
V_{OH}	Logic level, output voltage	High	$I_{\text{OH}} = -500\ \mu\text{A}$	0.9 DVDD		V
V_{OL}		Low	$I_{\text{OL}} = +500\ \mu\text{A}$		0.1 DVDD	V
I_{IN}	Input current	$0\text{ V} < V_{\text{DigitalInput}} < \text{DVDD}$		-10	+10	μA

ELECTRICAL CHARACTERISTICS (continued)

Minimum and maximum specifications apply from -40°C to $+105^{\circ}\text{C}$. Typical specifications are at $+25^{\circ}\text{C}$. All specifications are at $\text{DVDD} = 1.8\text{ V}$, $\text{AVDD} = 3\text{ V}$, $\text{AVSS} = 0\text{ V}$, $V_{\text{REF}} = 2.4\text{ V}$, external $f_{\text{CLK}} = 2.048\text{ MHz}$, data rate = 8 kSPS, and gain = 1, unless otherwise noted.

PARAMETER			TEST CONDITIONS	ADS130E08			UNIT
				MIN	TYP	MAX	
POWER-SUPPLY REQUIREMENTS							
AVDD	Analog supply	AVDD – AVSS		2.7	3	5.25	V
DVDD	Digital supply			1.7	1.8	3.6	V
		AVDD – DVDD		-2.1		3.6	V
SUPPLY CURRENT (Operational Amplifier Turned Off)							
I_{AVDD}	Normal operation	AVDD – AVSS = 3 V		1.8			mA
		AVDD – AVSS = 5 V		2.2			mA
DVDD = 3.3 V			0.5			mA	
DVDD = 1.8 V			0.3			mA	
I_{DVDD}							
POWER DISSIPATION							
Quiescent power dissipation (analog supply = 3 V)	Normal mode			6		6.6	mW
	Power-down mode			10			μW
	Standby mode			2			mW
Quiescent power dissipation (analog supply = 5 V)	Normal mode			11.5			mW
	Power-down mode			20			μW
	Standby mode			4			mW
TEMPERATURE							
Temperature range	Specified			-40		+105	$^{\circ}\text{C}$
	Operating			-40		+105	$^{\circ}\text{C}$
	Storage			-60		+150	$^{\circ}\text{C}$

THERMAL INFORMATION

THERMAL METRIC ⁽¹⁾			ADS130E08	UNITS
			PAG (TQFP)	
			64 PINS	
θ_{JA}	Junction-to-ambient thermal resistance		35	$^{\circ}\text{C}/\text{W}$
θ_{JCTop}	Junction-to-case (top) thermal resistance		31	
θ_{JB}	Junction-to-board thermal resistance		26	
ψ_{JT}	Junction-to-top characterization parameter		0.1	
ψ_{JB}	Junction-to-board characterization parameter		NA	
θ_{JCbott}	Junction-to-case (bottom) thermal resistance		NA	

(1) For more information about traditional and new thermal metrics, see the *IC Package Thermal Metrics* application report, [SPRA953](#).

PARAMETER MEASUREMENT INFORMATION

TIMING CHARACTERISTICS

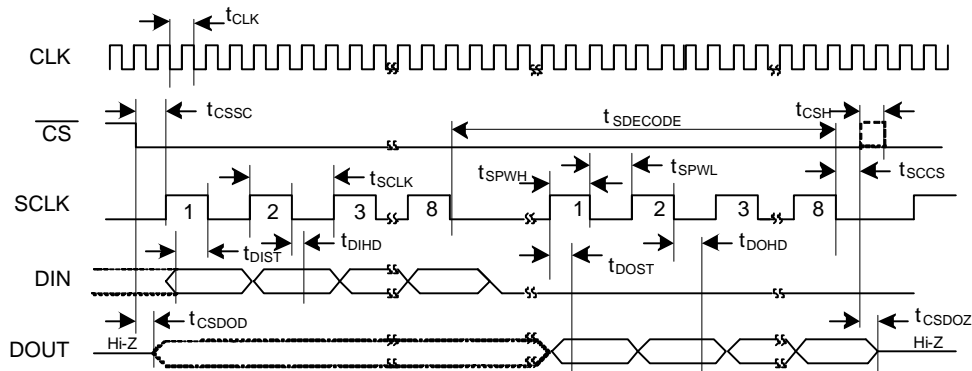

NOTE: SPI settings are CPOL = 0 and CPHA = 1.

Figure 1. Serial Interface Timing

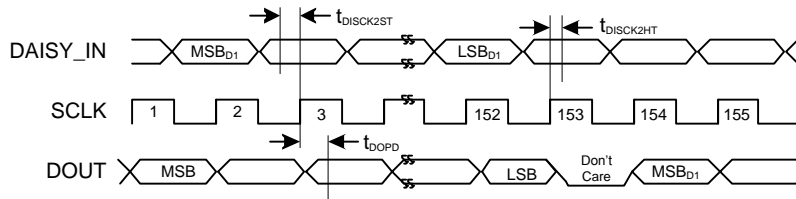

Figure 2. Daisy-Chain Interface Timing

Timing Requirements For Figure 1 and Figure 2⁽¹⁾

PARAMETER	DESCRIPTION	2.7 V ≤ DVDD ≤ 3.6 V		1.7 V ≤ DVDD ≤ 2.0 V		UNIT
		MIN	MAX	MIN	MAX	
t _{CLK}	Master clock period	414	514	414	514	ns
t _{CS}	\overline{CS} low to first SCLK: setup time	6		17		ns
t _{SCLK}	SCLK period	50		66.6		ns
t _{SPWH, L}	SCLK pulse width, high and low	15		25		ns
t _{DIST}	DIN valid to SCLK falling edge: setup time	10		10		ns
t _{DIHD}	Valid DIN after SCLK falling edge: hold time	10		11		ns
t _{DOHD}	SCLK falling edge to invalid DOUT: hold time	10		10		ns
t _{DOST}	SCLK rising edge to DOUT valid: setup time		17		32	ns
t _{CSH}	\overline{CS} high pulse	2		2		t _{CLKs}
t _{CSDOD}	\overline{CS} low to DOUT driven	10		20		ns
t _{SCCS}	Eighth SCLK falling edge to \overline{CS} high	4		4		t _{CLKs}
t _{SDECODE}	Command decode time	4		4		t _{CLKs}
t _{CSDOZ}	\overline{CS} high to DOUT Hi-Z		10		20	ns
t _{DISCK2ST}	Valid DAISY_IN to SCLK rising edge: setup time	10		10		ns
t _{DISCK2HT}	Valid DAISY_IN after SCLK rising edge: hold time	10		10		ns

(1) Specifications apply from -40°C to +105°C. Load on DOUT = 20 pF || 100 kΩ, unless otherwise noted.

PIN CONFIGURATION

PAG PACKAGE TQFP-64 (TOP VIEW)

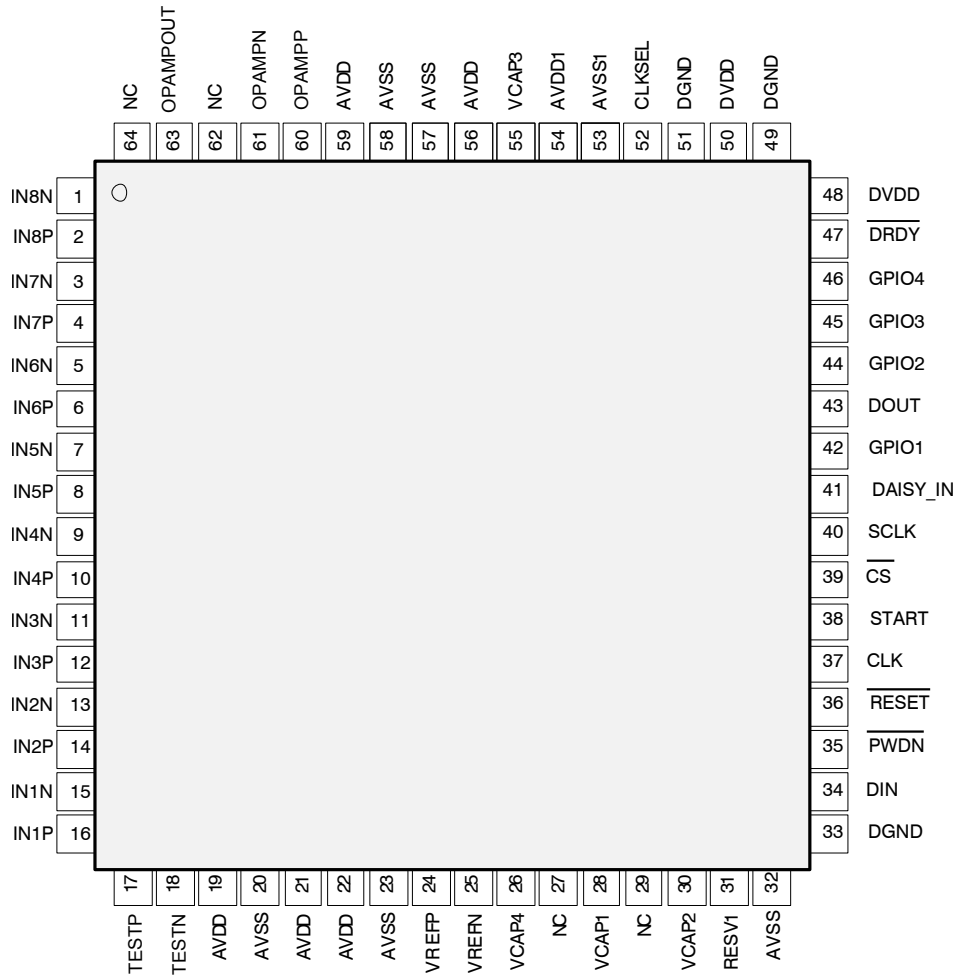

PIN ASSIGNMENTS

NAME	TERMINAL	FUNCTION	DESCRIPTION
AVDD	19, 21, 22, 56, 59	Supply	Analog supply
AVDD1	54	Supply	Charge pump analog supply
AVSS	20, 23, 32, 57, 58	Supply	Analog ground
AVSS1	53	Supply	Charge pump analog ground
CLK	37	Digital input	Master clock input
CLKSEL	52	Digital input	Master clock select
\overline{CS}	39	Digital input	SPI chip select; active low
DAISY_IN	41	Digital input	Daisy-chain input
DGND	33, 49, 51	Supply	Digital ground
DIN	34	Digital input	SPI data in
DOUT	43	Digital output	SPI data out
\overline{DRDY}	47	Digital output	Data ready; active low
DVDD	48, 50	Supply	Digital power supply
GPIO1	42	Digital input/output	General-purpose input/output pin

PIN ASSIGNMENTS (continued)

NAME	TERMINAL	FUNCTION	DESCRIPTION
GPIO2	44	Digital input/output	General-purpose input/output pin
GPIO3	45	Digital input/output	General-purpose input/output pin
GPIO4	46	Digital input/output	General-purpose input/output pin
IN1N ⁽¹⁾	15	Analog input	Differential analog negative input 1
IN1P	16	Analog input	Differential analog positive input 1
IN2N	13	Analog input	Differential analog negative input 2
IN2P	14	Analog input	Differential analog positive input 2
IN3N	11	Analog input	Differential analog negative input 3
IN3P	12	Analog input	Differential analog positive input 3
IN4N	9	Analog input	Differential analog negative input 4
IN4P	10	Analog input	Differential analog positive input 4
IN5N	7	Analog input	Differential analog negative input 5
IN5P	8	Analog input	Differential analog positive input 5
IN6N	5	Analog input	Differential analog negative input 6
IN6P	6	Analog input	Differential analog positive input 6
IN7N	3	Analog input	Differential analog negative input 7
IN7P	4	Analog input	Differential analog positive input 7
IN8N	1	Analog input	Differential analog negative input 8
IN8P	2	Analog input	Differential analog positive input 8
NC	27, 29, 62, 64	—	No connection, leave floating
OPAMPN	61	Analog	Op amp inverting input
OPAMPOUT	63	Analog	Op amp output
OPAMPP	60	—	Op amp noninverting input
PWDN	35	Digital input	Power-down; active low
RESET	36	Digital input	System reset; active low
RESV1	31	Digital input	Reserved for future use; must tie to logic low (DGND)
SCLK	40	Digital input	SPI clock
START	38	Digital input	Start conversion
TESTN ⁽²⁾	18	Analog output	Internal test signal
TESTP	17	Analog output	Internal test signal
VCAP1	28	Analog input and output	Analog bypass capacitor
VCAP2	30	—	Analog bypass capacitor
VCAP3	55	—	Analog bypass capacitor
VCAP4	26	Analog output	Analog bypass capacitor
VREFN	25	Analog input	Negative reference voltage
VREFP	24	Analog input and output	Positive reference voltage

(1) Connect unused IN1x to IN8x terminals to AVDD.

(2) Connect unused TESTx terminals to AVDD.

TYPICAL CHARACTERISTICS

All plots are at $T_A = +25^\circ\text{C}$, $AVDD = 3\text{ V}$, $AVSS = 0\text{ V}$, $DVDD = 1.8\text{ V}$, internal $VREFP = 2.4\text{ V}$, $VREFN = AVSS$, external clock = 2.048 MHz, data rate = 8 kSPS, and gain = 1, unless otherwise noted.

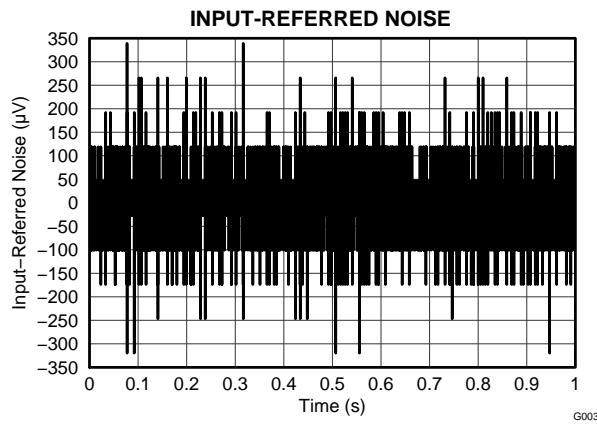

Figure 3.

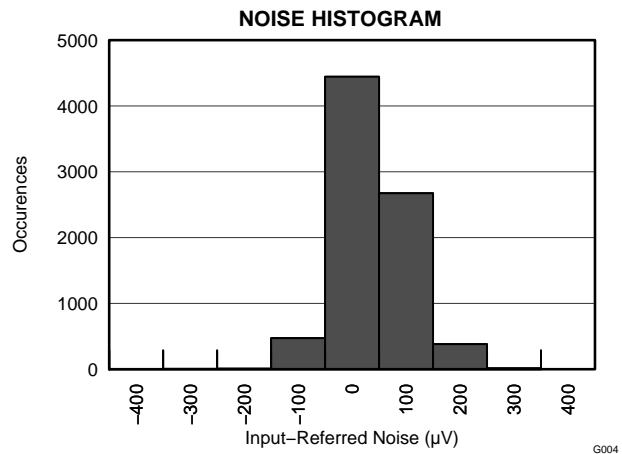

Figure 4.

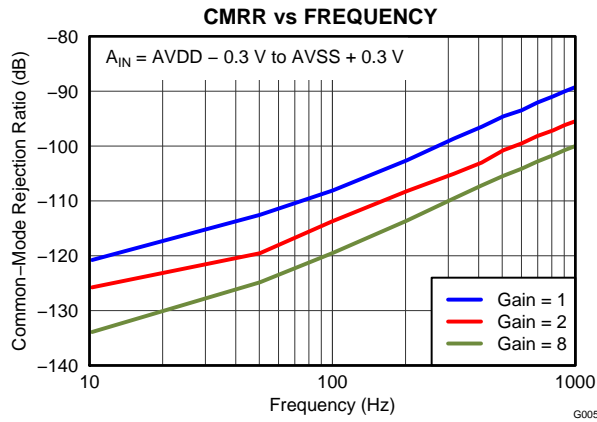

Figure 5.

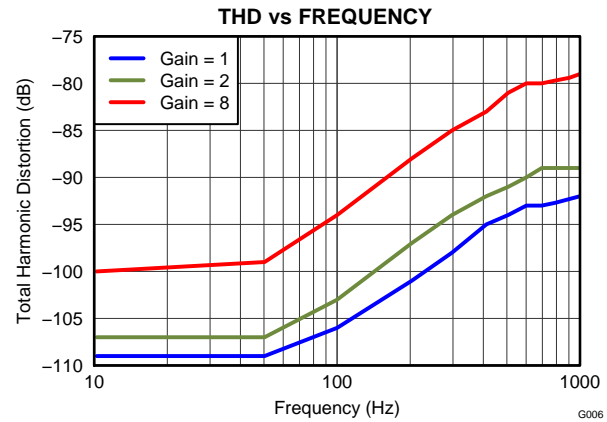

Figure 6.

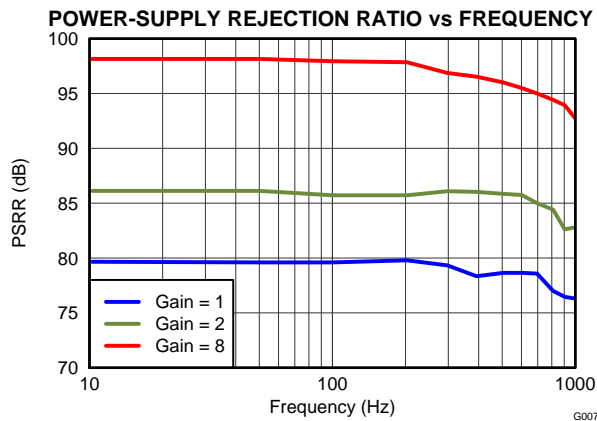

Figure 7.

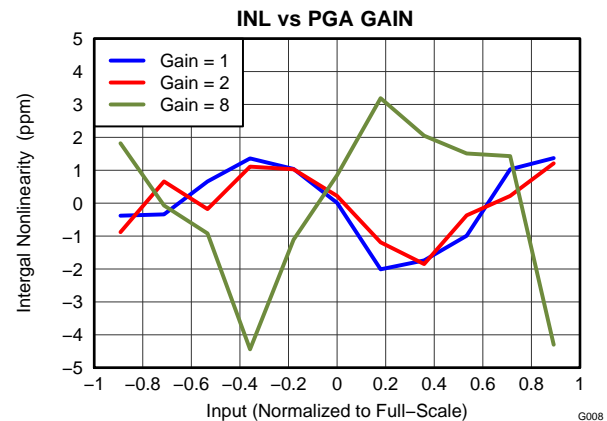

Figure 8.

TYPICAL CHARACTERISTICS (continued)

All plots are at $T_A = +25^\circ\text{C}$, $AVDD = 3\text{ V}$, $AVSS = 0\text{ V}$, $DVDD = 1.8\text{ V}$, internal $VREFP = 2.4\text{ V}$, $VREFN = AVSS$, external clock = 2.048 MHz, data rate = 8 kSPS, and gain = 1, unless otherwise noted.

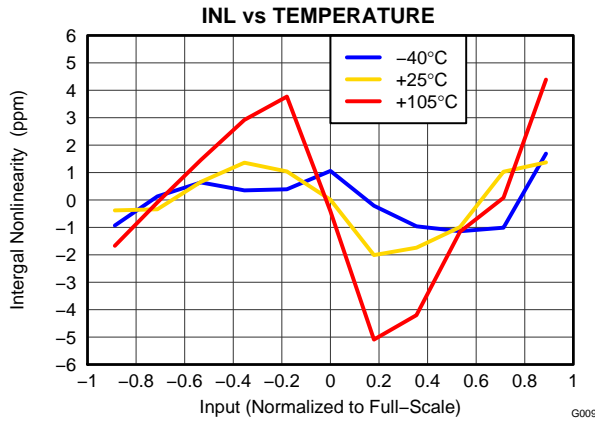

Figure 9.

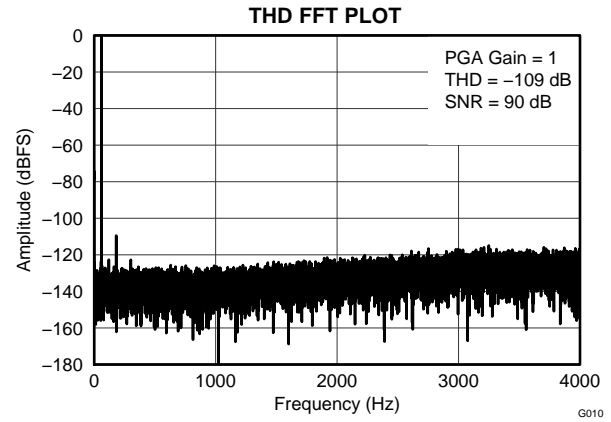

Figure 10.

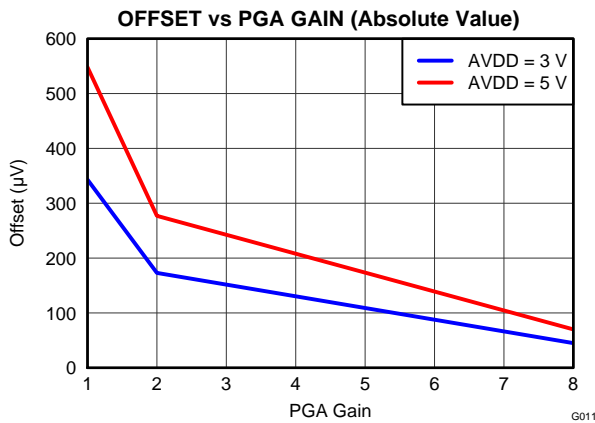

Figure 11.

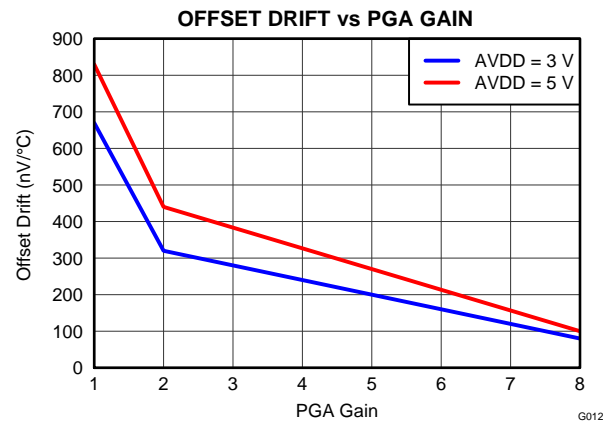

Figure 12.

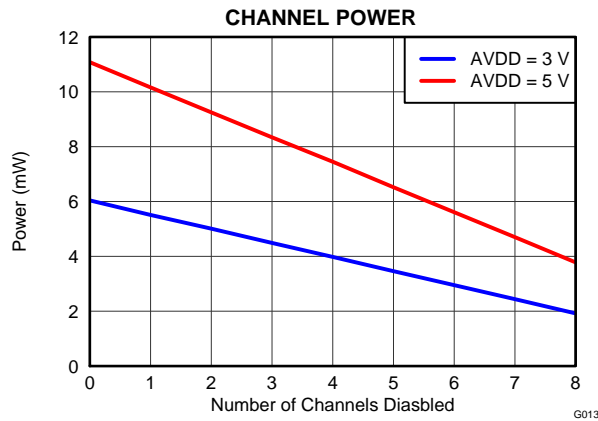

Figure 13.

OVERVIEW

The ADS130E08 is a low-power, multichannel, simultaneously-sampling, 16-bit, delta-sigma ($\Delta\Sigma$) analog-to-digital converter (ADC) with an integrated programmable gain amplifier (PGA). This functionality make the ADS130E08 suitable for industrial power-metering applications.

The ADS130E08 has a highly-programmable multiplexer that allows for temperature, supply, and input short measurements. PGA gain can be chosen from one of three settings (1, 2, and 8). The ADCs in the device offer a data rate of 8 kSPS. Communication to the device is accomplished using an SPI-compatible interface. The device provides four general-purpose IO (GPIO) pins for general use. Multiple devices can be synchronized using the START pin.

The internal reference can be programmed to either 2.4 V or 4 V. Fault detection can be accomplished by using the integrated comparators, with programmable trigger-point settings. A detailed diagram of the ADS130E08 is shown in [Figure 14](#).

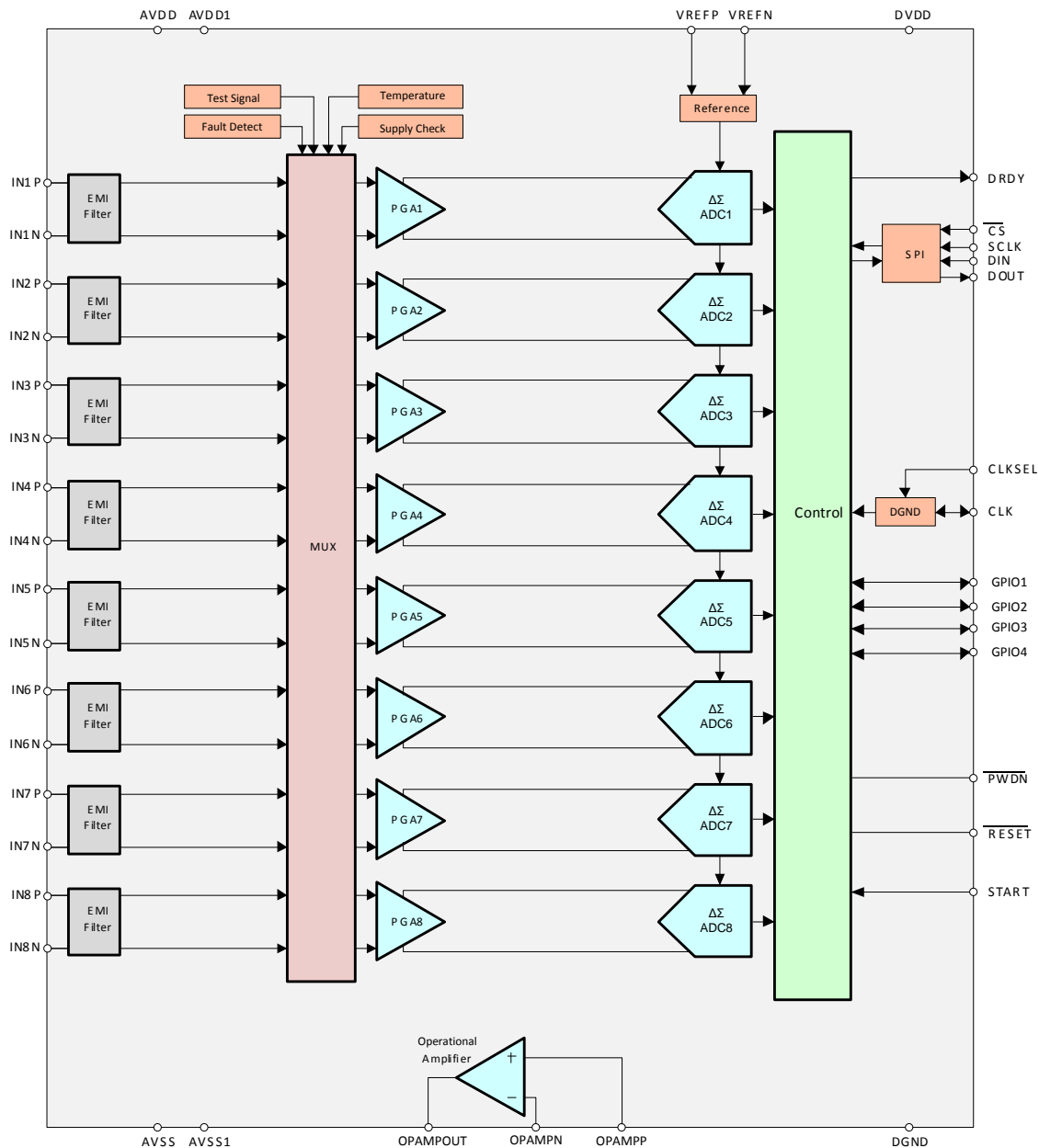

Figure 14. Functional Block Diagram

THEORY OF OPERATION

This section contains details of the ADS130E08 internal functional elements. The analog blocks are discussed first, followed by the digital interface. Blocks implementing power-specific functions are covered towards the end of this document.

Throughout this document, f_{CLK} denotes the CLK pin signal frequency, t_{CLK} denotes the CLK pin signal period, f_{DR} denotes the output data rate, t_{DR} denotes the output data time period, and f_{MOD} denotes the frequency at which the modulator samples the input.

EMI FILTER

An RC filter at the input acts as an electromagnetic interference (EMI) filter on all channels. The -3 -dB filter bandwidth is approximately 3 MHz.

INPUT MULTIPLEXER

The ADS130E08 input multiplexers are very flexible and provide many configurable signal-switching options. Figure 15 shows a diagram of the multiplexer on a single channel of the device. VINP and VINN are separate for each of the eight blocks. This flexibility allows for significant device and sub-system diagnostics, calibration, and configuration. Switch settings for each channel are selected by writing the appropriate values to the CHnSET register (see the *CHnSET: Individual Channel Settings (n = 1 to 8)* Register in the *Register Map* section for details.)

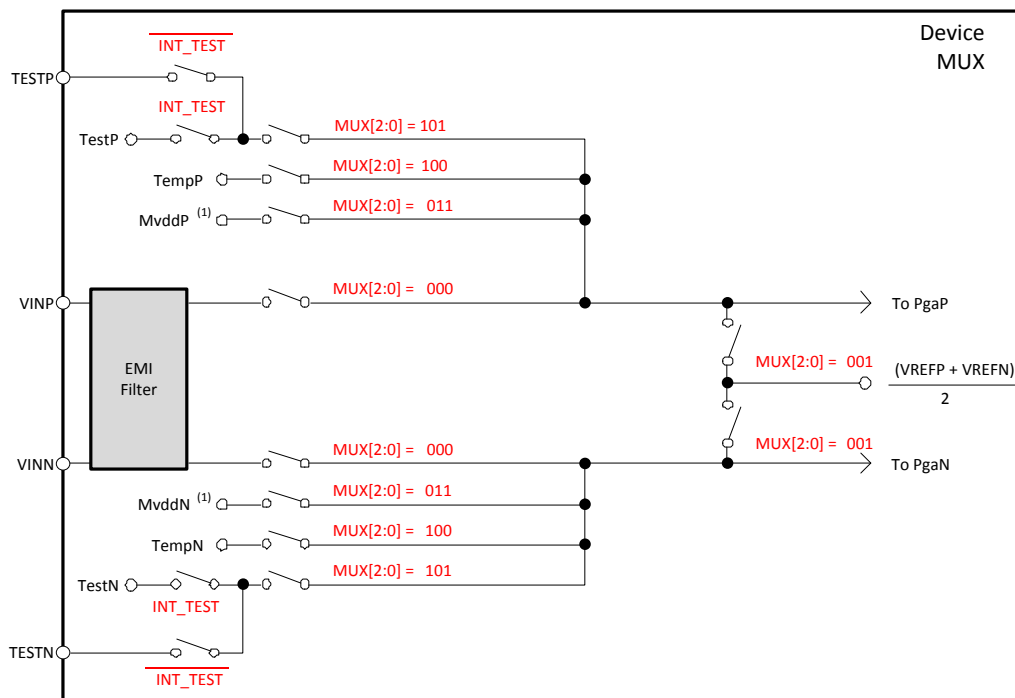

(1) MVDD monitor voltage supply depends on channel number; see the *Supply Measurements (MVDDP, MVDDN)* section.

Figure 15. Input Multiplexer Block for One Channel

Device Noise Measurements

Setting CHnSET[2:0] = 001 sets the common-mode voltage of [(VREFP + VREFN) / 2] to both inputs of the channel. This setting can be used to test inherent device noise in the user system.

Test Signals (TestP and TestN)

Setting CHnSET[2:0] = 101 provides internally-generated test signals for use in sub-system verification at power-up. Test signals are controlled through register settings (see the [CONFIG2: Configuration Register 2](#) subsection in the [Register Map](#) section for details). TEST_AMP controls the signal amplitude and TEST_FREQ controls switching at the required frequency. The test signals are multiplexed and transmitted out of the device at the TESTP and TESTN pins. A bit register (CONFIG2.INT_TEST = 0) deactivates the internal test signals so that the test signal can be driven externally. This feature allows the calibration of multiple devices with the same signal.

Temperature Sensor (TempP, TempN)

The ADS130E08 contains an on-chip temperature sensor. This sensor uses two internal diodes with one diode having a current density 16x that of the other, as shown in [Figure 16](#). The difference in diode current densities yields a difference in voltage that is proportional to absolute temperature.

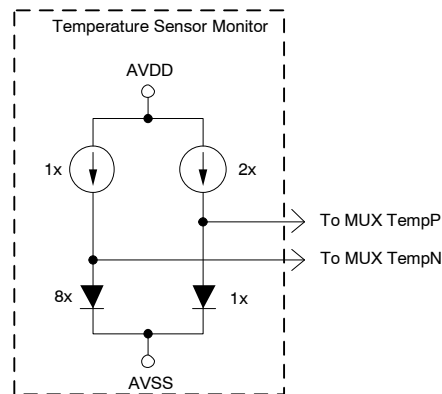

Figure 16. Temperature Sensor Measurement in the Input

As a result of the low thermal resistance of the package to the printed circuit board (PCB), the internal device temperature tracks the PCB temperature closely. Note that self-heating of the ADS130E08 causes a higher reading than the temperature of the surrounding PCB.

The scale factor of [Equation 1](#) converts the temperature reading to degrees Celsius. Before using this equation, the temperature reading code must first be scaled to microvolts.

$$\text{Temperature (}^{\circ}\text{C)} = \left[\frac{\text{Temperature Reading (}\mu\text{V)} - 168,000 \mu\text{V}}{394 \mu\text{V}/^{\circ}\text{C}} \right] + 25^{\circ}\text{C} \quad (1)$$

Supply Measurements (MVDDP, MVDDN)

Setting CHnSET[2:0] = 011 sets the channel inputs to different supply voltages of the device. For channels 1, 2, 5, 6, 7, and 8, (MVDDP – MVDDN) is [0.5(AVDD – AVSS)]; for channels 3 and 4, (MVDDP – MVDDN) is DVDD / 4. Note that to avoid saturating the PGA while measuring power supplies, the gain must be set to '1'.

ANALOG INPUT

The ADS130E08 analog input is fully differential. Assuming $PGA = 1$, the input ($INP - INN$) can span between $-V_{REF}$ to $+V_{REF}$. Refer to [Table 3](#) for an explanation of the correlation between the analog input and the digital codes. There are two general methods of driving the ADS130E08 analog input: single-ended or differential, as shown in [Figure 17](#) and [Figure 18](#). Note that INP and INN are 180° out-of-phase in the differential input method. When the input is single-ended, the INN input is held at the common-mode voltage, preferably at mid-supply. The INP input swings around the same common voltage and the peak-to-peak amplitude is $(\text{common-mode} + 1/2 V_{REF})$ and $(\text{common-mode} - 1/2 V_{REF})$. When the input is differential, the common-mode is given by $(INP + INN) / 2$. Both INP and INN inputs swing from $(\text{common-mode} + 1/2 V_{REF})$ to $(\text{common-mode} - 1/2 V_{REF})$. For optimal performance, it is recommended that the ADS130E08 be used in a differential configuration.

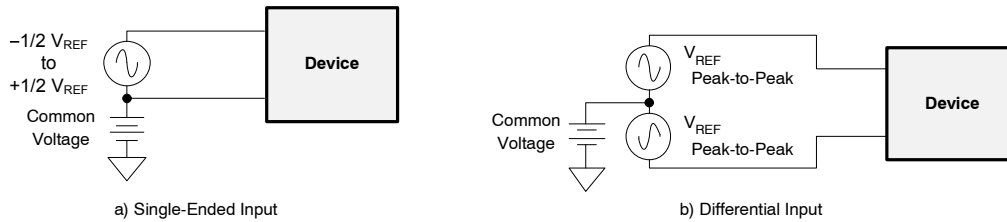

Figure 17. Methods of Driving the ADS130E08: Single-Ended or Differential

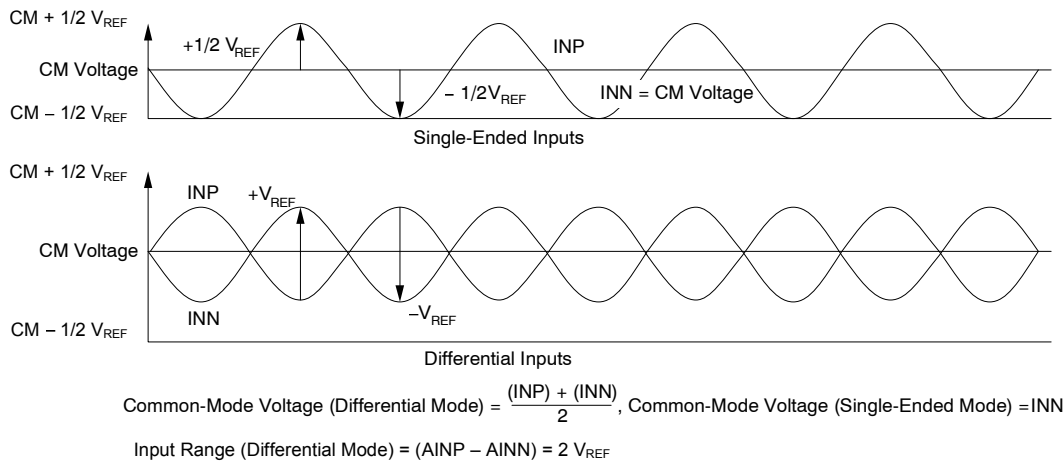

Figure 18. Using the ADS130E08 in Single-Ended and Differential Input Modes

PGA SETTINGS AND INPUT RANGE

The PGA is a differential input and output amplifier, as shown in [Figure 19](#). The PGA has three gain settings (1, 2, and 8) that can be set by writing to the CHnSET register (see the [CHnSET: Individual Channel Settings \(n = 1 to 8\)](#) Register in the [Register Map](#) section for details). The ADS130E08 has CMOS inputs and, therefore, has negligible current noise. [Table 1](#) shows the typical bandwidth values for various gain settings. Note that [Table 1](#) only shows small-signal bandwidth. For large signals, performance is limited by PGA slew rate.

The PGA resistor string that implements the gain has 120 kΩ of resistance. This resistance provides a current path across the PGA outputs in the presence of a differential input signal. This current is in addition to the quiescent current specified for the device in the presence of a differential signal at the input.

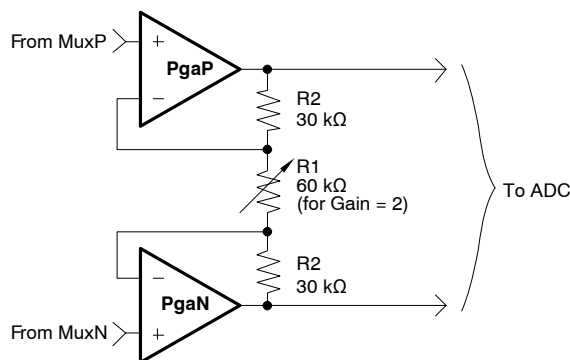

Figure 19. PGA Implementation

Table 1. PGA Gain versus Bandwidth

GAIN	NOMINAL BANDWIDTH AT ROOM TEMPERATURE (kHz)
1	237
2	146
8	48

Input Common-Mode Range

The usable input common-mode range of the analog front-end depends on various parameters, including the maximum differential input signal, supply voltage, and PGA gain. Equation 2 describes this range.

$$AVDD - 0.2 - \left[\frac{\text{Gain } V_{\text{MAX_DIFF}}}{2} \right] > \text{CM} > AVSS + 0.2 + \left[\frac{\text{Gain } V_{\text{MAX_DIFF}}}{2} \right]$$

where:

$V_{\text{MAX_DIFF}}$ = maximum differential signal at the PGA input

CM = common-mode range

(2)

For example:

If $V_{\text{DD}} = 3.3 \text{ V}$, gain = 2, and $V_{\text{MAX_DIFF}} = 1000 \text{ mV}$,

Then $1.2 \text{ V} < \text{CM} < 2.1 \text{ V}$

Input Differential Dynamic Range

The differential (INP – INN) signal range depends on the analog supply and reference used in the system. Equation 3 shows this range.

$$\text{Max (INP – INN)} < \frac{V_{\text{REF}}}{\text{Gain}} ; \quad \text{Full-Scale Range} = \frac{\pm V_{\text{REF}}}{\text{Gain}} = \frac{2 V_{\text{REF}}}{\text{Gain}} \quad (3)$$

For higher dynamic range, a 5-V supply with a 4-V reference (set by the VREF_4V bit of the [CONFIG3: Configuration Register 3](#)) can be used to increase the differential dynamic range.

ADC $\Delta\Sigma$ Modulator

Each ADS130E08 channel has a 16-bit, $\Delta\Sigma$ ADC. This converter uses a second-order modulator optimized for low-power applications. The modulator samples the input signal at the rate of $f_{\text{MOD}} = f_{\text{CLK}} / 8$. As in the case of any $\Delta\Sigma$ modulator, the ADS130E08 noise is shaped until $f_{\text{MOD}} / 2$, as shown in Figure 20. The on-chip digital decimation filters also provide antialias filtering. This feature of the $\Delta\Sigma$ converters drastically reduces the complexity of analog antialiasing filters typically required with nyquist ADCs.

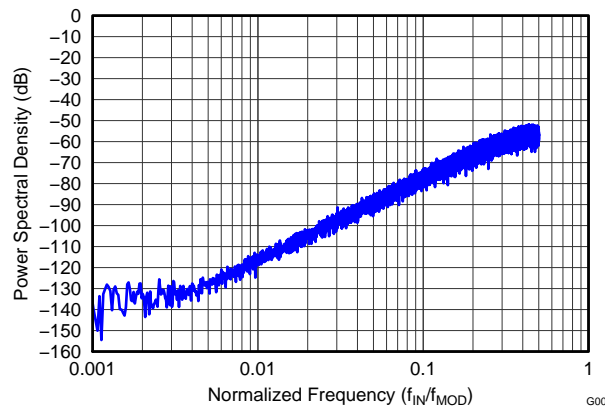

Figure 20. Modulator Noise Spectrum Up To $0.5 \times f_{\text{MOD}}$

DIGITAL DECIMATION FILTER

The digital filter receives the modulator output and decimates the data stream. A fixed sample rate of 8 kSPS, for all eight channels, is provided for simplicity. The digital filter on each channel consists of a third-order sinc filter.

Sinc Filter Stage (sinx / x)

The sinc filter is a variable decimation rate, third-order, low-pass filter. Data are supplied to this section of the filter from the modulator at the rate of f_{MOD} . The sinc filter attenuates the high-frequency noise of the modulator, then decimates the data stream into parallel data. The decimation rate affects the overall data rate of the converter.

[Equation 4](#) shows the scaled Z-domain transfer function of the sinc filter.

$$|H(z)| = \left| \frac{1 - Z^{-N}}{1 - Z^{-1}} \right|^3 \quad (4)$$

The frequency domain transfer function of the sinc filter is shown in [Equation 5](#).

$$H(f) = \left| \frac{\sin \left(\frac{N\pi f}{f_{\text{MOD}}} \right)}{N \times \sin \left(\frac{\pi f}{f_{\text{MOD}}} \right)} \right|^3$$

where:

$$N = \text{decimation ratio} \quad (5)$$

The sinc filter has notches (or zeroes) that occur at the output data rate and multiples thereof. At these frequencies, the filter has infinite attenuation. Figure 21 shows the sinc filter frequency response and Figure 22 shows the sinc filter roll-off. With a step change at the input, the filter takes $3 t_{DR}$ to settle. After a START signal rising edge, the filter takes t_{SETTLE} time to output settled data. The settling time of the filters at various data rates is discussed in the *START* subsection of the *SPI Interface* section. Figure 23 and Figure 24 show the filter transfer function until $f_{MOD} / 2$ and $f_{MOD} / 16$, respectively, at different data rates. Figure 25 shows the transfer function extended until $4 f_{MOD}$. The ADS130E08 passband repeats at every f_{MOD} . The input R-C antialiasing filters in the system should be chosen such that any interference in frequencies around multiples of f_{MOD} is attenuated sufficiently.

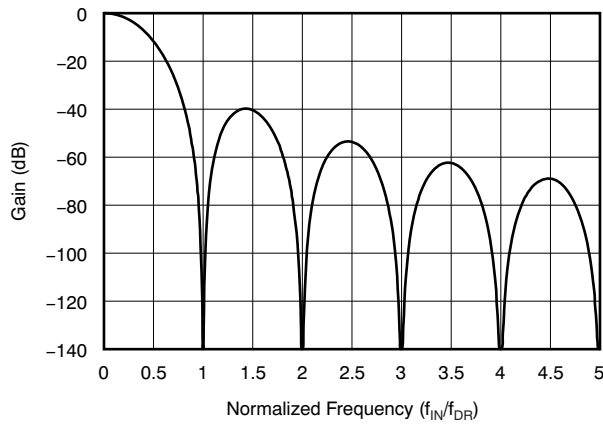

Figure 21. Sinc Filter Frequency Response

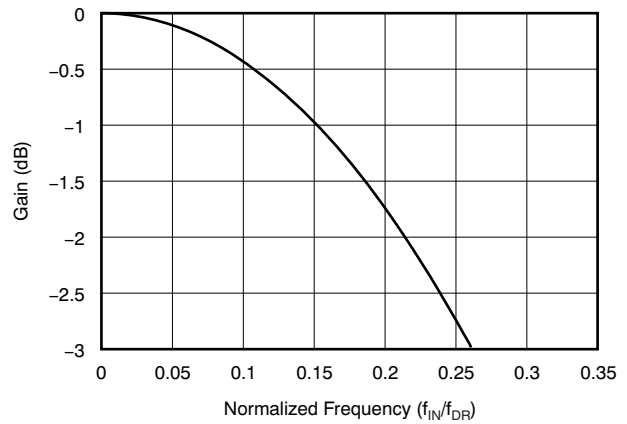

Figure 22. Sinc Filter Roll-Off

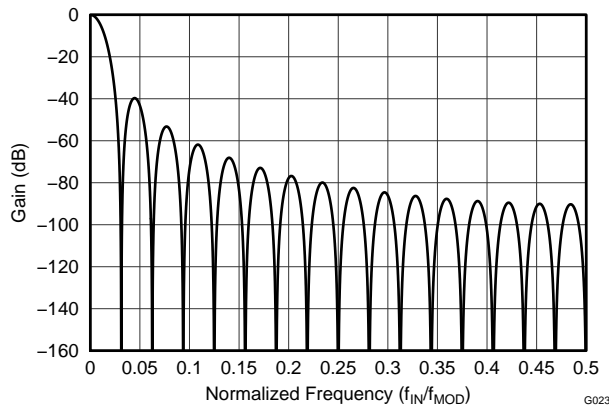

Figure 23. Transfer Function of On-Chip Decimation Filters Until $f_{MOD} / 2$

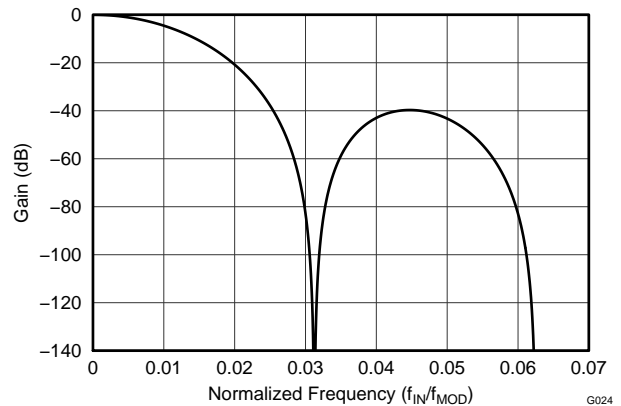

Figure 24. Transfer Function of On-Chip Decimation Filters Until $f_{MOD} / 16$

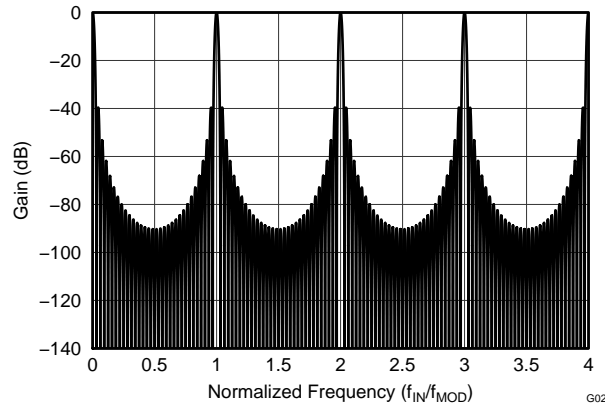
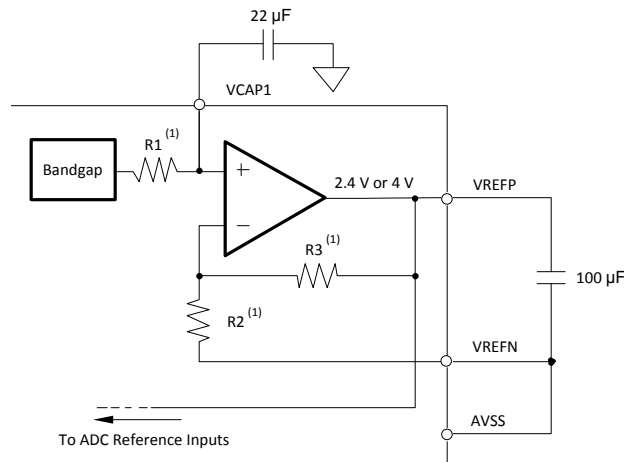

Figure 25. Transfer Function of On-Chip Decimation Filters Until $4 f_{MOD}$ for DR[2:0] = 000 and DR[2:0] = 110

REFERENCE

Figure 26 shows a simplified block diagram of the ADS130E08 internal reference. The reference voltage is generated with respect to AVSS. When using the internal voltage reference, connect VREFN to AVSS.



(1) For $V_{REF} = 2.4\text{ V}$: $R1 = 12.5\text{ k}\Omega$, $R2 = 25\text{ k}\Omega$, and $R3 = 25\text{ k}\Omega$. For $V_{REF} = 4\text{ V}$: $R1 = 10.5\text{ k}\Omega$, $R2 = 15\text{ k}\Omega$, and $R3 = 35\text{ k}\Omega$.

Figure 26. Internal Reference

The external band-limiting capacitors determine the amount of reference noise contribution. For high-end systems, the capacitor values should be chosen such that the bandwidth is limited to less than 10 Hz so that the reference noise does not dominate system noise. When using a 3-V analog supply, the internal reference must be set to 2.4 V. In case of a 5-V analog supply, the internal reference can be set to 4 V by setting the VREF_4V bit in the [CONFIG2: Configuration Register 2](#).

Alternatively, the internal reference buffer can be powered down and VREFP can be driven externally. Figure 27 shows a typical external reference driver circuitry. Power-down is controlled by the PD_REFBUF bit in the [CONFIG3: Configuration Register 3](#). This power-down is also used to share internal references when two devices are cascaded. By default, the device wakes up in external reference mode.

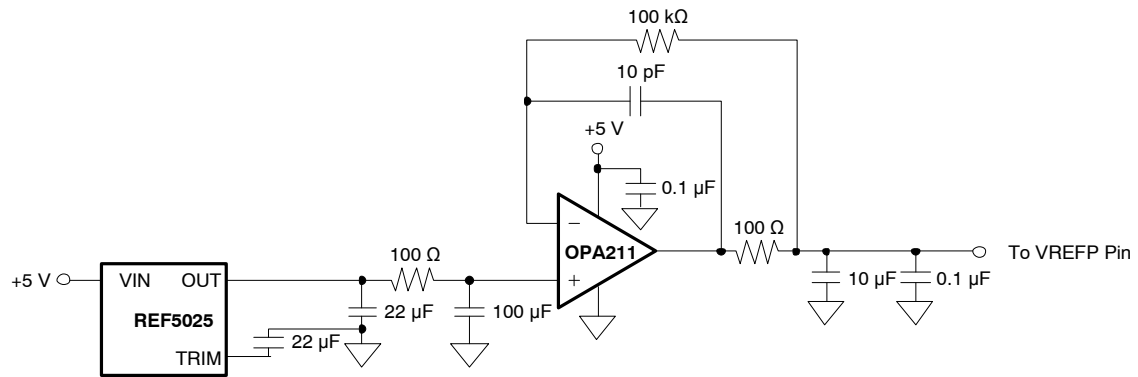

Figure 27. External Reference Driver

CLOCK

The ADS130E08 provides two device clocking methods: internal and external. Internal clocking is ideally suited for low-power, battery-powered systems. The internal oscillator is trimmed for accuracy at room temperature. Accuracy varies over the specified temperature range; refer to the [Electrical Characteristics](#) for details. Clock selection is controlled by the CLKSEL pin and CLK_EN register bit.

The CLKSEL pin selects either the internal or external clock. The CLK_EN bit in the CONFIG1 register enables and disables the oscillator clock to be output in the CLK pin. A truth table for these pins is shown in [Table 2](#). The CLK_EN bit is useful when multiple devices are used in a daisy-chain configuration. During power-down, the external clock is recommended to be shut down to save power.

Table 2. CLKSEL Pin and CLK_EN Bit

CLKSEL PIN	CONFIG1.CLK_EN BIT	CLOCK SOURCE	CLK PIN STATUS
0	X	External clock	Input: external clock
1	0	Internal clock oscillator	3-state
1	1	Internal clock oscillator	Output: internal clock oscillator

DATA FORMAT

The ADS130E08 outputs 16 bits of data per channel in binary two's complement format, MSB first. The LSB has a weight of $[V_{REF} / (2^{15} - 1)]$. A positive full-scale input produces an output code of 7FFFh and the negative full-scale input produces an output code of 8000h. The output clips at these codes for signals exceeding full-scale. [Table 3](#) summarizes the ideal output codes for different input signals.

Table 3. Ideal Output Code versus Input Signal

INPUT SIGNAL, V_{IN} (AINP – AINN)	IDEAL OUTPUT CODE ⁽¹⁾
$\geq V_{REF}$	7FFFh
$+V_{REF} / (2^{15} - 1)$	0001h
0	0000h
$-V_{REF} / (2^{15} - 1)$	FFFFh
$\leq -V_{REF} (2^{15} / 2^{15} - 1)$	8000h

(1) Excludes effects of noise, linearity, offset, and gain error.

SPI INTERFACE

The SPI-compatible serial interface consists of four signals: \overline{CS} , SCLK, DIN, and DOUT. The interface reads conversion data, reads and writes registers, and controls device operation. The \overline{DRDY} output is used as a status signal to indicate when data are ready. \overline{DRDY} goes low when new data are available.

Chip Select (\overline{CS})

\overline{CS} selects the ADS130E08 for SPI communication. \overline{CS} must remain low for the entire serial communication duration. After the serial communication is finished, always wait four or more t_{CLK} cycles before taking \overline{CS} high. When \overline{CS} is taken high, the serial interface is reset, SCLK and DIN are ignored, and DOUT enters a high-impedance state. \overline{DRDY} asserts when data conversion is complete, regardless of whether \overline{CS} is high or low.

Serial Clock (SCLK)

SCLK is the serial peripheral interface (SPI) serial clock. SCLK shifts commands in and shifts data out from the device. The serial clock features a Schmitt-triggered input and clocks data on the DIN and DOUT pins into and out of the ADS130E08.

Care should be taken to prevent glitches on SCLK while \overline{CS} is low. Glitches as small as 1 ns wide could be interpreted as a valid serial clock. After eight serial clock events, the ADS130E08 assumes an instruction must be interrupted and executed. If it is suspected that instructions are being interrupted erroneously, toggle \overline{CS} high and back low to return the chip to normal operation. Issuing serial clocks in multiples of eight is also recommended. The absolute maximum SCLK limit is specified in the [Serial Interface Timing](#) table.

For a single device, the minimum speed needed for SCLK depends on the number of channels, number of bits of resolution, and output data rate. (For multiple cascaded devices, see the [Standard Mode](#) subsection of the [Multiple Device Configuration](#) section.) For example, at 8 kSPS, the minimum serial clock rate must be 1.3 MHz.

Data can be retrieved either by putting the device in RDATA mode or by issuing an RDATA command for data on demand. The SCLK rate limitation, as described by [Equation 6](#), applies to RDATA mode. For the RDATA command, the limitation applies if data must be read in between two consecutive DRDY signals. [Equation 6](#) assumes that there are no other commands issued in between data captures.

$$t_{SCLK} < \frac{t_{DR} - 4 t_{CLK}}{152} \tag{6}$$

Data Input (DIN)

The data input pin (DIN) is used along with SCLK to communicate with the ADS130E08 (using opcode commands and register data). The device latches data on DIN on the SCLK falling edge.

Data Output (DOUT)

The data output pin (DOUT) is used with SCLK to read conversions and register data from the ADS130E08. Data on DOUT are shifted out on the SCLK rising edge. DOUT goes to a high-impedance state when \overline{CS} is high. In read data continuous mode (see the [SPI Command Definitions](#) section for more details), the DOUT output line also indicates when new data are available. This feature can be used to minimize the number of connections between the device and system controller. [Figure 28](#) shows the data output protocol for the ADS130E08.

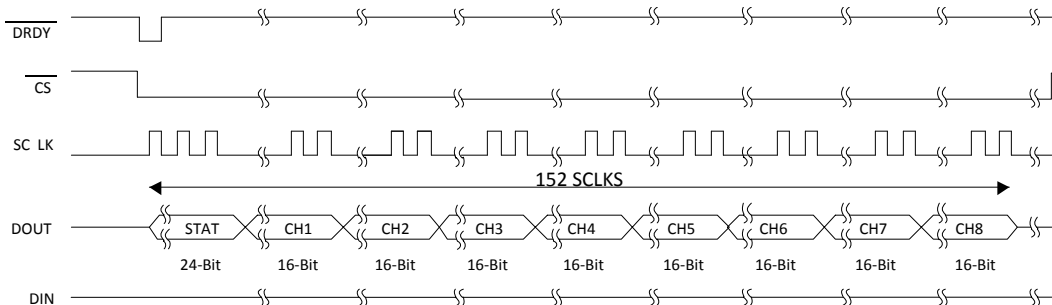

Figure 28. SPI Bus Data Output

Data Retrieval

Data retrieval can be accomplished in one of two methods. The read data continuous command (see the [RDATA: Read Data Continuous](#) section) can be used to set the device in a mode to read data continuously without sending opcodes. The read data command (see the [RDATA: Read Data](#) section) can be used to read just one data output from the device (see the [SPI Command Definitions](#) section for more details). Conversion data are read by shifting data out on DOUT. The MSB of the data on DOUT is clocked out on the first SCLK rising edge. DRDY returns to high on the first SCLK falling edge. DIN should remain low for the entire read operation.

The number of bits in the data output depends on the number of channels and the number of bits per channel. For the ADS130E08, the number of data outputs is [(24 status bits + 16 bits × 8 channels) = 152 bits]. The format of the 24 status bits is (1100 + FAULT_STATP + FAULT_STATN + bits[7:4] of the [GPIO: General-Purpose IO Register](#)). The data format for each channel data is twos complement, MSB first. When channels are powered down using user register settings, the corresponding channel output is set to '0'. However, the channel output sequence remains the same.

The ADS130E08 also provides a multiple readback feature. Data can be read out multiple times by simply giving more SCLKs, in which case the MSB data byte repeats after reading the last byte. The DAISY_IN bit in the *CONFIG1: Configuration Register 1* must be set to '1' for multiple readbacks.

Data Ready ($\overline{\text{DRDY}}$)

$\overline{\text{DRDY}}$ is an output. When $\overline{\text{DRDY}}$ transitions low, new conversion data are ready. The $\overline{\text{CS}}$ signal has no effect on the data ready signal. $\overline{\text{DRDY}}$ behavior is determined by whether the device is in RDATAC mode or the RDATA command is being used to read data on demand. (See the *RDATAC: Read Data Continuous* and *RDATA: Read Data* subsections of the *SPI Command Definitions* section for further details). When reading data with the RDATA command, the read operation can overlap the next $\overline{\text{DRDY}}$ occurrence without data corruption.

The START pin or the START command is used to place the device either in normal data capture mode or pulse data capture mode. Figure 29 shows the relationship between $\overline{\text{DRDY}}$, DOUT, and SCLK during data retrieval. DOUT is latched out at the SCLK rising edge; $\overline{\text{DRDY}}$ is pulled high at the SCLK falling edge. Note that $\overline{\text{DRDY}}$ goes high on the first SCLK falling edge, regardless of whether data are being retrieved from the device or a command is being sent through the DIN pin.

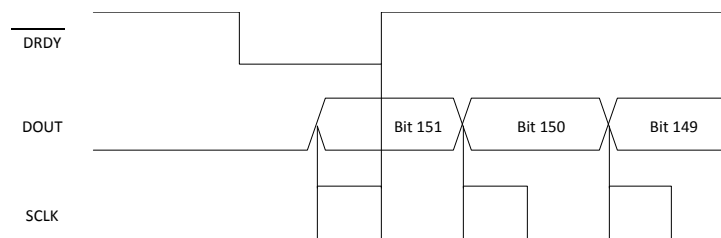

Figure 29. $\overline{\text{DRDY}}$ with Data Retrieval ($\overline{\text{CS}} = 0$)

GPIO

The ADS130E08 has a total of four general-purpose digital input and output (GPIO) pins available in the normal mode of operation. The digital IO pins are individually configurable as either inputs or outputs through the GPIOC bits register. The GPIOD bits in the *GPIO: General-Purpose IO Register* control the level of the pins. When reading the GPIOD bits, the data returned are the logic level of the pins, whether they are programmed as inputs or outputs. When the GPIO pin is configured as an input, a write to the corresponding GPIOD bit has no effect. When configured as an output, a write to the GPIOD bit sets the output value.

If configured as inputs, these pins must be driven (do not float). The GPIO pins are set as inputs after power-on or after a reset. Figure 30 shows the GPIO port structure. The pins should be connected to DGND if not used.

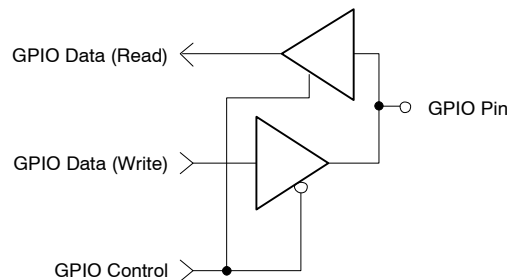

Figure 30. GPIO Port Pin

Power-Down ($\overline{\text{PWDN}}$)

When $\overline{\text{PWDN}}$ is pulled low, all on-chip circuitry is powered down. To exit power-down mode, take the $\overline{\text{PWDN}}$ pin high. Upon exiting from power-down mode, the internal oscillator and reference require time to wake up. During power-down, the external clock is recommended to be shut down to save power.

Reset (RESET)

There are two methods to reset the ADS130E08: pulling the $\overline{\text{RESET}}$ pin low, or sending the $\overline{\text{RESET}}$ opcode command. When using the $\overline{\text{RESET}}$ pin, take the pin low to force a reset. Make sure to follow the minimum pulse width timing specifications before taking the $\overline{\text{RESET}}$ pin back high. The $\overline{\text{RESET}}$ command takes effect on the eighth SCLK falling edge of the opcode command. On reset, $18 t_{\text{CLK}}$ cycles are required to complete initialization of the configuration registers to the default states and start the conversion cycle. Note that an internal $\overline{\text{RESET}}$ is automatically issued to the digital filter whenever the CONFIG1 Register is set to a new value with a WREG command.

START

The START pin must be set high or the START command sent to begin conversions. When START is low or if the START command has not been sent, the device does not issue a $\overline{\text{DRDY}}$ signal (conversions are halted).

When using the START opcode to control conversions, hold the START pin low. In multiple device configurations the START pin is used to synchronize devices (see the [Multiple Device Configuration](#) subsection of the [SPI Interface](#) section for more details).

Settling Time

The settling time (t_{SETTLE}) is the time required for the converter to output fully-settled data when the START signal is pulled high. When START is pulled high, $\overline{\text{DRDY}}$ is also pulled high. The next $\overline{\text{DRDY}}$ falling edge indicates that data are ready. Figure 31 shows the timing diagram and shows the data rate settling time. The settling time depends on f_{CLK} and is $1160 t_{\text{CLK}}$. Note that when START is held high and there is a step change in the input signal, $3 t_{\text{DR}}$ is required for the filter to settle to the new value. Settled data are available on the fourth $\overline{\text{DRDY}}$ pulse.

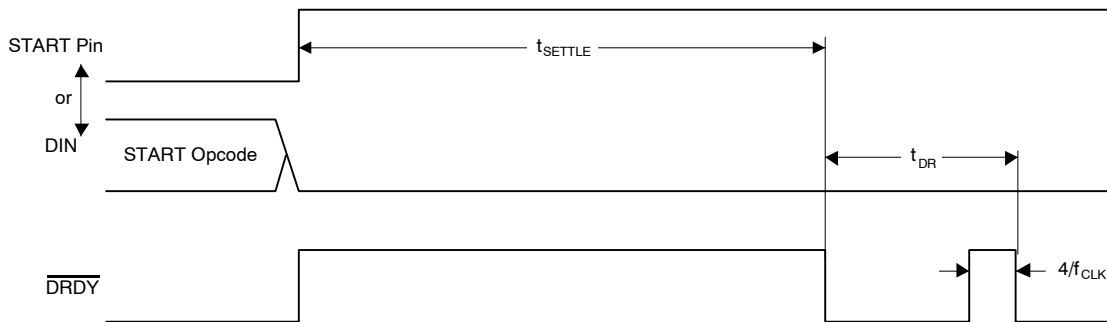
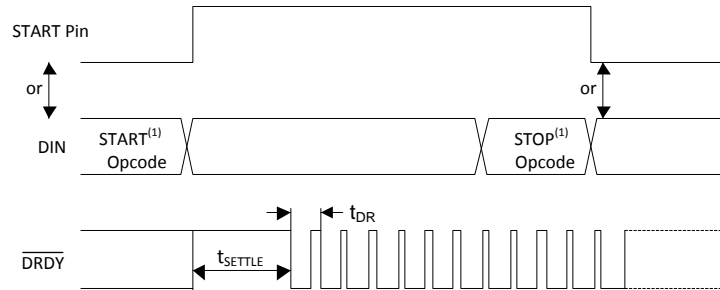

Figure 31. Settling Time

Continuous Mode

Conversions begin when the START pin is taken high or when the START opcode command is sent. As seen in Figure 32, the $\overline{\text{DRDY}}$ output goes high when conversions are started and then goes low when data are ready. Conversions continue indefinitely until the START pin is taken low or the STOP opcode command is transmitted. When the START pin is pulled low or the stop command is issued, the conversion in progress is allowed to complete. Figure 33 and Table 4 show the required $\overline{\text{DRDY}}$ timing to the START pin and the START and STOP opcode commands when controlling conversions in this mode. To keep the converter running continuously, the START pin can be permanently tied high.



(1) START and STOP opcode commands take effect on the seventh SCLK falling edge.

Figure 32. Continuous Conversion Mode

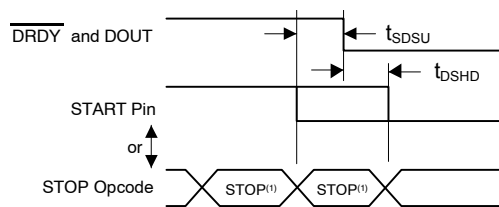

(1) START and STOP commands take effect on the seventh SCLK falling edge at the end of the opcode transmission.

Figure 33. START to $\overline{\text{DRDY}}$ Timing

Table 4. Timing Characteristics for Figure 33⁽¹⁾

SYMBOL	DESCRIPTION	MIN	UNIT
t_{SDSU}	START pin low or STOP opcode to $\overline{\text{DRDY}}$ setup time to halt further conversions	16	$1/f_{\text{CLK}}$
t_{DSHD}	START pin low or STOP opcode to complete current conversion	16	$1/f_{\text{CLK}}$

(1) START and STOP commands take effect on the seventh SCLK falling edge at the end of the opcode transmission.

MULTIPLE DEVICE CONFIGURATION

The ADS130E08 is designed to provide configuration flexibility when multiple devices are used in a system. The serial interface typically needs four signals: DIN, DOUT, SCLK, and \overline{CS} . With one additional chip select signal per device, multiple devices can be connected together. The number of signals needed to interface n devices is $3 + n$.

When using multiple devices, the devices can be synchronized with the START signal. The delay from START to the \overline{DRDY} signal is fixed for a fixed data rate (see the *START* subsection of the *SPI Interface* section for more details on settling times). Figure 34 shows the behavior of two devices when synchronized with the START signal.

There are two ways to connect multiple devices with an optimal number of interface pins: cascade mode and daisy-chain mode.

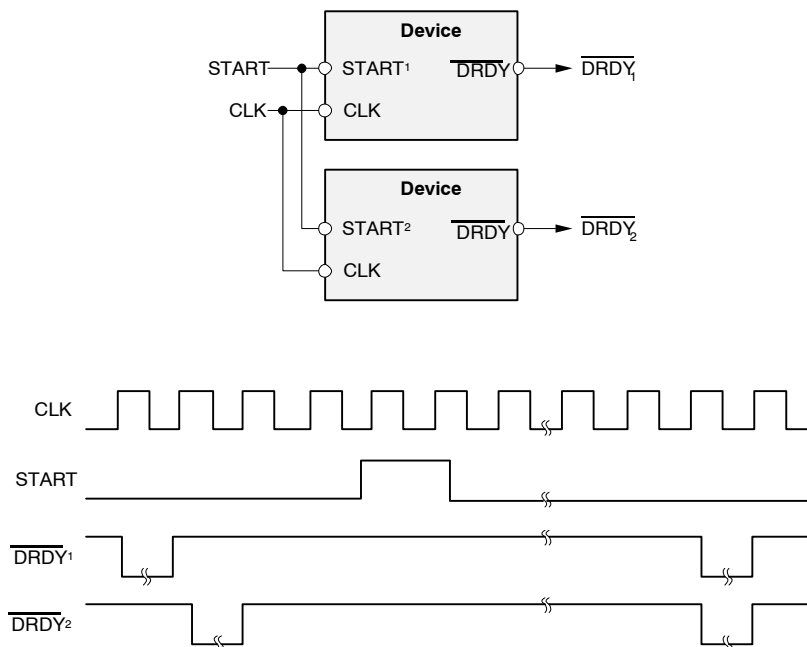

Figure 34. Synchronizing Multiple Converters

Cascade Mode

Figure 35a shows a configuration with two devices cascaded together. Both devices are an ADS130E08 device. Together, the devices create a system with 16 channels. DOUT, SCLK, and DIN are shared. Each device has its own chip select. When a device is not selected by the corresponding CS being driven to logic '1', the DOUT of this device is high-impedance. This structure allows the other device to take control of the DOUT bus. This configuration method is suitable for the majority of applications.

Daisy-Chain Mode

Daisy-chain mode is enabled by setting the DAISY_IN bit in the *CONFIG1: Configuration Register 1*. Figure 35b shows the daisy-chain configuration. In this mode SCLK, DIN, and CS are shared across multiple devices. The DOUT pin of one device is connected to the DAISY_IN of the other device, thereby creating a chain. One extra SCLK must be issued between each data set. Also, when using daisy-chain mode, the multiple readback feature is not available. Short the DAISY_IN pin to digital ground if not used. Figure 2 describes the required timing for the ADS130E08 shown in Figure 35. Data from the ADS130E08 appear first on DOUT, followed by a *don't care* bit, and finally by the status and data words from the second ADS130E08 device.

When all devices in the chain operate in the same register setting, DIN can be shared as well. This configuration reduces the SPI communication signals to four, regardless of the number of devices.

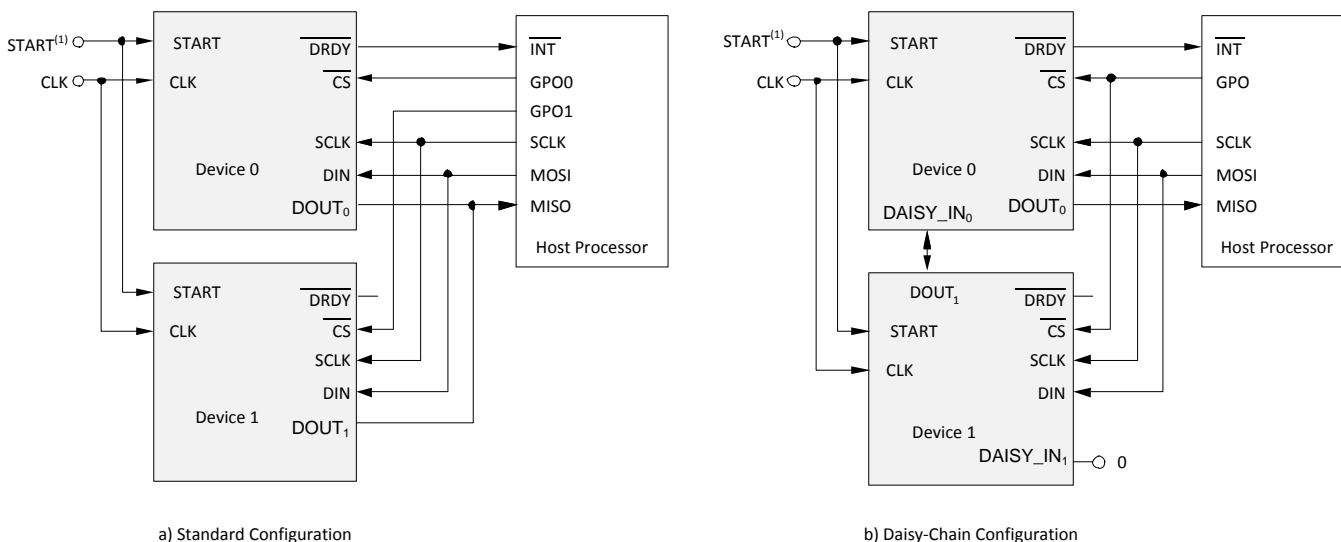

(1) To reduce pin count, set the START pin low and use the START serial command to synchronize and start conversions.

Figure 35. Multiple Device Configurations

Note that from [Figure 2](#), the SCLK rising edge shifts data out of the ADS130E08 on DOUT. The SCLK rising edge is also used to latch data into the device DAISY_IN pin down the chain. This architecture allows for a faster SCLK rate speed, but also makes the interface sensitive to board-level signal delays. The more devices in the chain, the more challenging it can become to adhere to setup and hold times. An SCLK star-pattern connection to all devices, minimizing DOUT length, and other printed circuit board (PCB) layout techniques helps. Placing delay circuits (such as buffers) between DOUT and DAISY_IN also helps mitigate this challenge. One other option is to insert a *D* flip-flop between DOUT and DAISY_IN clocked on an inverted SCLK. Also note that daisy-chain mode requires some software overhead to recombine data bits spread across byte boundaries. [Figure 36](#) shows a timing diagram for daisy-chain mode.

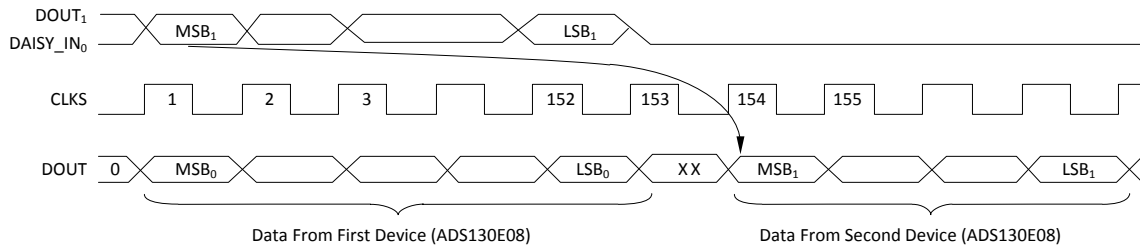

Figure 36. Daisy-Chain Timing

The maximum number of devices that can be daisy-chained depends on the data rate at which the device is operated at. The maximum number of devices can be approximately calculated with [Equation 7](#).

$$N_{\text{DEVICES}} = \frac{f_{\text{SCLK}}}{152 \times f_{\text{DR}}} \tag{7}$$

SPI COMMAND DEFINITIONS

The ADS130E08 provides flexible configuration control. The opcode commands summarized in [Table 5](#) control and configure device operation. The opcode commands are stand-alone, except for the register read and write operations that require a second command byte plus data. \overline{CS} can be taken high or held low between opcode commands but must stay low for the entire command operation (especially for multibyte commands). System opcode commands and the RDATA command are decoded by the ADS130E08 on the seventh SCLK falling edge. The register read and write opcodes are decoded on the eighth SCLK falling edge. Be sure to follow SPI timing requirements when pulling \overline{CS} high after issuing a command.

Table 5. Command Definitions

COMMAND	DESCRIPTION	FIRST BYTE	SECOND BYTE
System Commands			
WAKEUP	Wake-up from standby mode	0000 0010 (02h)	
STANDBY	Enter standby mode	0000 0100 (04h)	
\overline{RESET}	Reset the device	0000 0110 (06h)	
START	Start or restart (synchronize) conversions	0000 1000 (08h)	
STOP	Stop conversion	0000 1010 (0Ah)	
Data Read Commands			
RDATAC	Enable Read Data Continuous mode. This mode is the default mode at power-up. ⁽¹⁾	0001 0000 (10h)	
SDATAC	Stop Read Data Continuously mode	0001 0001 (11h)	
RDATA	Read data by command; supports multiple readback.	0001 0010 (12h)	
Register Read Commands			
RREG	Read n $nnnn$ registers starting at address r $rrrr$	001 r $rrrr$ (2xh) ⁽²⁾	000 n $nnnn$ ⁽²⁾
WREG	Write n $nnnn$ registers starting at address r $rrrr$	010 r $rrrr$ (4xh) ⁽²⁾	000 n $nnnn$ ⁽²⁾

(1) When in RDATAC mode, the RREG command is ignored.

(2) n $nnnn$ = number of registers to be read or written – 1. For example, to read or write three registers, set n $nnnn$ = 0 (0010). r $rrrr$ = starting register address for read and write opcodes.

WAKEUP: Exit STANDBY Mode

This opcode exits the low-power standby mode; see the [STANDBY: Enter STANDBY Mode](#) subsection of the [SPI Command Definitions](#) section. Time is required when exiting standby mode (see the [Electrical Characteristics](#) for details). **There are no SCLK rate restrictions for this command and it can be issued at any time.** The next command must be sent after a delay of 4 t_{CLK} cycles.

STANDBY: Enter STANDBY Mode

This opcode command enters the low-power standby mode. All parts of the circuit are shut down except for the reference section. The standby mode power consumption is specified in the [Electrical Characteristics](#). **There are no SCLK rate restrictions for this command and it can be issued at any time.** Do not send any other commands other than the wakeup command after the device enters standby mode.

\overline{RESET} : Reset Registers to Default Values

This command resets the digital filter cycle and returns all register settings to the default values. See the [Reset \(RESET\)](#) subsection of the [SPI Interface](#) section for more details. **There are no SCLK rate restrictions for this command and it can be issued at any time.** 18 t_{CLK} cycles are required to execute the \overline{RESET} command. Avoid sending any commands during this time.

START: Start Conversions

This opcode starts data conversions. Tie the START pin low to control conversions by command. If conversions are in progress, this command has no effect. The STOP opcode command is used to stop conversions. If the START command is immediately followed by a STOP command, then a gap of 4 t_{CLK} cycles must be between them. When the START opcode is sent to the device, keep the START pin low until the STOP command is issued. (See the [START](#) subsection of the [SPI Interface](#) section for more details.) **There are no SCLK rate restrictions for this command and it can be issued at any time.**

STOP: Stop Conversions

This opcode stops conversions. Tie the START pin low to control conversions by command. When the STOP command is sent, the conversion in progress completes and further conversions are stopped. If conversions are already stopped, this command has no effect. **There are no SCLK rate restrictions for this command and it can be issued at any time.**

RDATAC: Read Data Continuous

This opcode enables conversion data output on each $\overline{\text{DRDY}}$ without the need to issue subsequent read data opcodes. This mode places the conversion data in the output register and may be shifted out directly. The read data continuous mode is the device default mode; the device defaults to this mode on power-up.

RDATAC mode is cancelled by the Stop Read Data Continuous command. If the device is in RDATAC mode, an SDATAC command must be issued before any other commands can be sent to the device. There is no SCLK rate restriction for this command. However, the subsequent data-retrieval SCLKs or the SDATAC opcode command should wait at least $4 t_{\text{CLK}}$ cycles for the command to execute. RDATAC timing is shown in Figure 37. As Figure 37 shows, there is a *keep out zone* of $4 t_{\text{CLK}}$ cycles around the $\overline{\text{DRDY}}$ pulse where this command cannot be issued in. If no data are retrieved from the device, DOUT and $\overline{\text{DRDY}}$ behave similarly in this mode. To retrieve data from the device after the RDATAC command is issued, make sure either the START pin is high or the START command is issued. Figure 37 shows the recommended way to use the RDATAC command. RDATAC is ideally-suited for applications such as data loggers or recorders where registers are set once and do not need to be reconfigured.

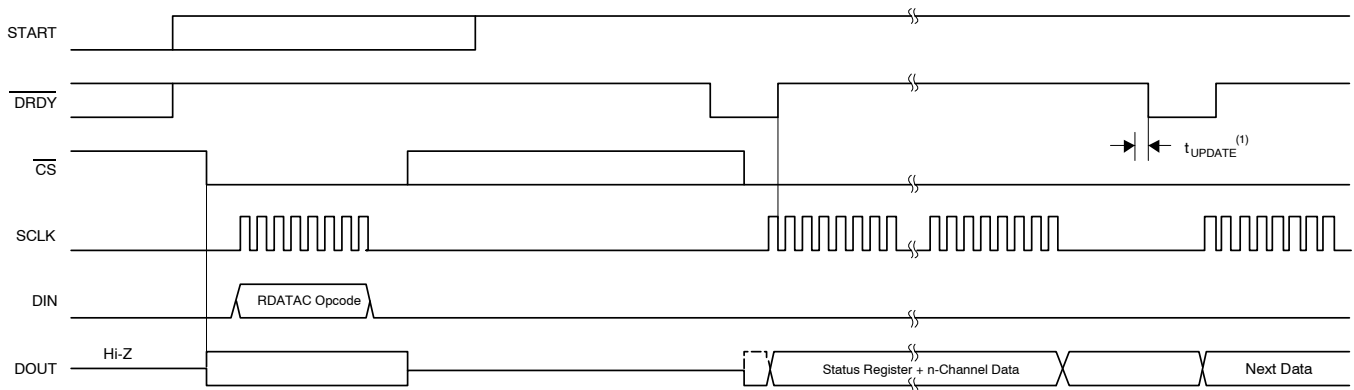

(1) $t_{\text{UPDATE}} = 4 / f_{\text{CLK}}$. Do not read data during this time.

Figure 37. RDATAC Usage

SDATAC: Stop Read Data Continuous

This opcode cancels the Read Data Continuous mode. There is no SCLK rate restriction for this command, but the next command must wait 4 t_{CLK} cycles to execute.

RDATA: Read Data

Issue this command after \overline{DRDY} goes low to read the conversion result (in Stop Read Data Continuous mode). There is no SCLK rate restriction for this command, and there is no wait time needed for subsequent commands or data-retrieval SCLKs. To retrieve data from the device after the RDATA command is issued, make sure either the START pin is high or the START command is issued. When reading data with the RDATA command, the read operation can overlap the next \overline{DRDY} occurrence without data corruption. Figure 38 shows the recommended way to use the RDATA command. RDATA is best suited for systems where register settings must be read or changed often between conversion cycles.

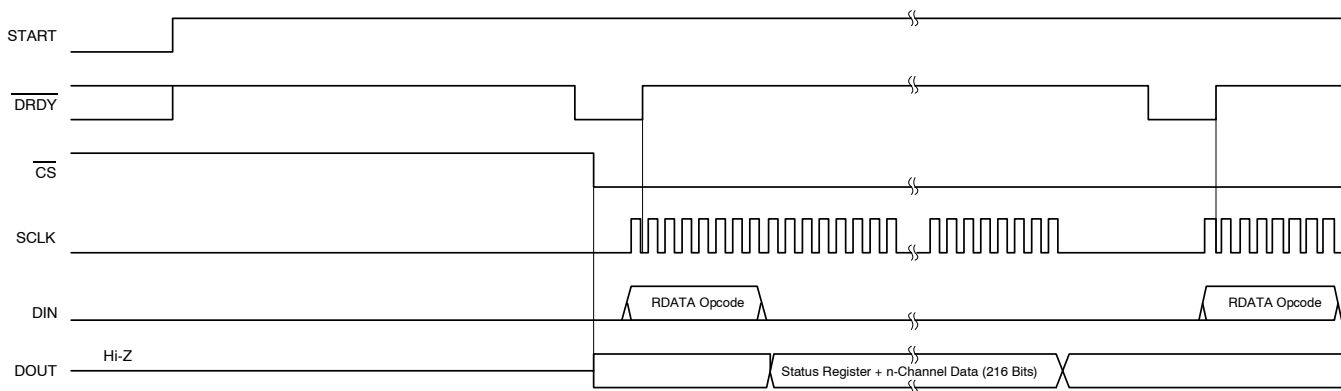

Figure 38. RDATA Usage

Sending Multibyte Commands

The ADS130E08 serial interface decodes commands in bytes and requires 4 t_{CLK} cycles to decode and execute. Therefore, when sending multibyte commands, a 4- t_{CLK} period must separate the end of one byte (or opcode) and the next.

Assuming CLK is 2.048 MHz, then $t_{SDECODE}$ (4 t_{CLK}) is 1.96 μ s. When SCLK is 16 MHz, one byte can be transferred in 500 ns. This byte-transfer time does not meet the $t_{SDECODE}$ specification; therefore, a delay must be inserted so the end of the second byte arrives 1.46 μ s later. If SCLK is 4 MHz, one byte is transferred in 2 μ s. Because this transfer time exceeds the $t_{SDECODE}$ specification, the processor can send subsequent bytes without delay. In this later scenario, the serial port can be programmed to move from single-byte transfers per cycle to multiple bytes.

RREG: Read From Register

This opcode reads register data. The Register Read command is a two-byte opcode followed by the register data output. The first byte contains the command opcode and register address. The second opcode byte specifies the number of registers to read – 1.

First opcode byte: 001r rrrr, where r rrrr is the starting register address.

Second opcode byte: 000n nnnn, where n nnnn is the number of registers to read – 1.

The 17th SCLK rising edge of the operation clocks out the MSB of the first register, as shown in Figure 39. When the device is in read data continuous mode, an SDATAC command must be issued before the RREG command can be issued. The RREG command can be issued at any time. However, because this command is a multibyte command, there are SCLK rate restrictions depending on how the SCLKs are issued. See the [Serial Clock \(SCLK\)](#) subsection of the [SPI Interface](#) section for more details. Note that \overline{CS} must be low for the entire command.

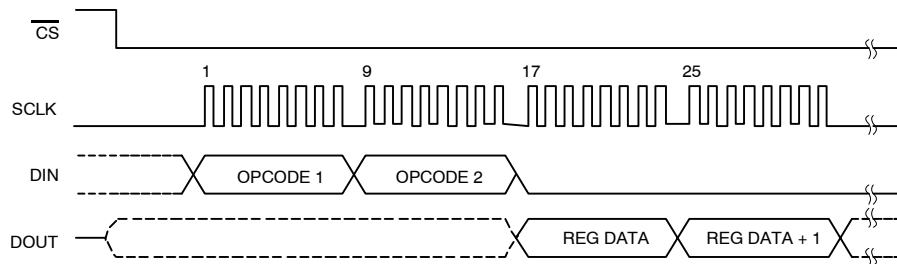

Figure 39. RREG Command Example: Read Two Registers Starting from Register 00h (ID Register) (OPCODE 1 = 0010 0000, OPCODE 2 = 0000 0001)

WREG: Write to Register

This opcode writes register data. The Register Write command is a two-byte opcode followed by the register data input. The first byte contains the command opcode and the register address.

The second opcode byte specifies the number of registers to write – 1.

First opcode byte: 010r rrrr, where r rrrr is the starting register address.

Second opcode byte: 000n nnnn, where n nnnn is the number of registers to write – 1.

After the opcode bytes, the register data follows (in MSB-first format), as shown in Figure 40. The WREG command can be issued at any time. However, because this command is a multibyte command, there are SCLK rate restrictions depending on how the SCLKs are issued. See the [Serial Clock \(SCLK\)](#) subsection of the [SPI Interface](#) section for more details. Note that \overline{CS} must be low for the entire command.

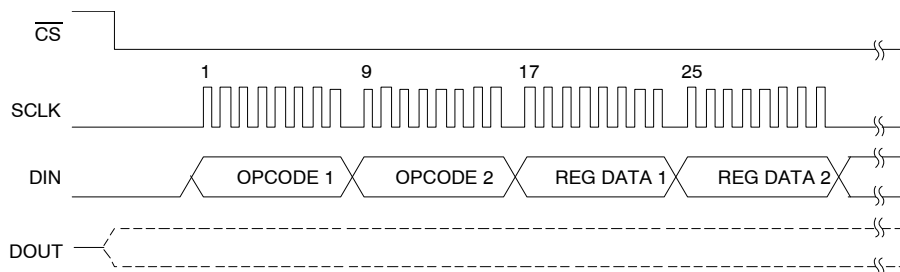

Figure 40. WREG Command Example: Write Two Registers Starting from 00h (ID Register) (OPCODE 1 = 0100 0000, OPCODE 2 = 0000 0001)

REGISTER MAP

Table 6 describes the various ADS130E08 registers.

Table 6. Register Assignments⁽¹⁾

ADDRESS	REGISTER	RESET VALUE (Hex)	BIT 7	BIT 6	BIT 5	BIT 4	BIT 3	BIT 2	BIT 1	BIT 0
Device Settings (Read-Only Registers)										
00h	ID	52	REV_ID3	REV_ID2	REV_ID1	1	0	DEV_ID1	NU_CH2	NU_CH1
Global Settings Across Channels										
01h	CONFIG1	01	0	0	CLK_EN	0	0	0	0	1
02h	CONFIG2	60	0	1	1	INT_TEST	0	TEST_AMP	TEST_FREQ1	TEST_FREQ0
03h	CONFIG3	40	PD_REFBUF	1	VREF_4V	0	OPAMP_REF	PD_OPAMP	0	0
04h	FAULT	00	COMP_TH2	COMP_TH1	COMP_TH0	0	0	0	0	0
Channel-Specific Settings										
05h	CH1SET	10	PD1	GAIN12	GAIN11	GAIN10	0	MUX12	MUX11	MUX10
06h	CH2SET	10	PD2	GAIN22	GAIN21	GAIN20	0	MUX22	MUX21	MUX20
07h	CH3SET	10	PD3	GAIN32	GAIN31	GAIN30	0	MUX32	MUX31	MUX30
08h	CH4SET	10	PD4	GAIN42	GAIN41	GAIN40	0	MUX42	MUX41	MUX40
09h	CH5SET	10	PD5	GAIN52	GAIN51	GAIN50	0	MUX52	MUX51	MUX50
0Ah	CH6SET	10	PD6	GAIN62	GAIN61	GAIN60	0	MUX62	MUX61	MUX60
0Bh	CH7SET	10	PD7	GAIN72	GAIN71	GAIN70	0	MUX72	MUX71	MUX70
0Ch	CH8SET	10	PD8	GAIN82	GAIN81	GAIN80	0	MUX82	MUX81	MUX80
Fault Detect Status Registers (Read-Only Registers)										
12h	FAULT_STATP	00	IN8P_FAULT	IN7P_FAULT	IN6P_FAULT	IN5P_FAULT	IN4P_FAULT	IN3P_FAULT	IN2P_FAULT	IN1P_FAULT
13h	FAULT_STATN	00	IN8N_FAULT	IN7N_FAULT	IN6N_FAULT	IN5N_FAULT	IN4N_FAULT	IN3N_FAULT	IN2N_FAULT	IN1N_FAULT
GPIO and Other Registers										
14h	GPIO	0F	GPIOD4	GPIOD3	GPIOD2	GPIOD1	GPIOC4	GPIOC3	GPIOC2	GPIOC1

(1) Registers 0Dh, 0Eh, 0Fh, 10h, and 11h must be written as all '0's.

User Register Description

ID: ID Control Register (Factory-Programmed, Read-Only)

Address = 00h

BIT 7	BIT 6	BIT 5	BIT 4	BIT 3	BIT 2	BIT 1	BIT 0
REV_ID3	REV_ID2	REV_ID1	1	0	DEV_ID1	NU_CH2	NU_CH1

This register is programmed during device manufacture to indicate device characteristics.

- Bits[7:5] REV_ID[3:1]: Device family identification (read-only)**
 These factory-programmed bits indicate the device version.
 010 = ADS130E08
 All others are reserved.
- Bit 4 Must be set to '1'**
- Bit 3 Must be set to '0'**
- Bits[1:0] DEV_ID1 and NU_CH[2:1]: Device identification bits (read-only)**
 These factory-programmed bits indicate the device version.
 010 = ADS130E08
 All others are reserved.

CONFIG1: Configuration Register 1

Address = 01h

BIT 7	BIT 6	BIT 5	BIT 4	BIT 3	BIT 2	BIT 1	BIT 0
0	0	CLK_EN	0	0	0	0	1

This register is reserved for device manufacturing.

- Bits[7:6] Must be set to '0'**
- Bit 5 CLK_EN: CLK connection⁽¹⁾**
 This bit determines if the internal oscillator signal is connected to the CLK pin when the CLKSEL pin is '1'.
 0 = Oscillator clock output disabled (default)
 1 = Oscillator clock output enabled
- Bits[4:1] Must be set to '0'**
- Bit 0 Must be set to '1'**

(1) Additional power is consumed when driving external devices.

CONFIG2: Configuration Register 2

Address = 02h

BIT 7	BIT 6	BIT 5	BIT 4	BIT 3	BIT 2	BIT 1	BIT 0
0	1	1	INT_TEST	0	TEST_AMP	TEST_FREQ1	TEST_FREQ0

This register configures test signal generation. See the [Input Multiplexer](#) section for more details.

- Bit 7** **Must be set to '0'**
- Bits[6:5]** **Must be set to '1'**
- Bit 4** **INT_TEST: Test source**
 This bit determines the test signal source.
 0 = Test signals are driven externally (default)
 1 = Test signals are generated internally
- Bit 3** **Must be set to '0'**
- Bit 2** **TEST_AMP: Test signal amplitude**
 This bit determines the Calibration signal amplitude.
 0 = $1 \times -(V_{REFP} - V_{REFN}) / 2.4 \text{ mV}$ (default)
 1 = $2 \times -(V_{REFP} - V_{REFN}) / 2.4 \text{ mV}$
- Bits[1:0]** **TEST_FREQ[1:0]: Test signal frequency**
 These bits determine the calibration signal frequency.
 00 = Pulsed at $f_{CLK} / 2^{21}$ (default)
 01 = Pulsed at $f_{CLK} / 2^{20}$
 10 = Not used
 11 = At dc

CONFIG3: Configuration Register 3

Address = 03h

BIT 7	BIT 6	BIT 5	BIT 4	BIT 3	BIT 2	BIT 1	BIT 0
PD_REFBUF	1	VREF_4V	0	OPAMP_REF	PD_OPAMP	0	0

This register configures multireference operation.

- Bit 7** **PD_REFBUF: Power-down reference buffer**
 This bit determines the power-down reference buffer state.
 0 = Power-down internal reference buffer (default)
 1 = Enable internal reference buffer
- Bit 6** **Must be set to '1'**
 Default is '1' at power-up.
- Bit 5** **VREF_4V: Reference voltage**
 This bit determines the reference voltage, VREFP.
 0 = VREFP is set to 2.4 V (default)
 1 = VREFP is set to 4 V (only use with a 5-V analog supply)
- Bit 4** **Must be set to '0'**
- Bit 3** **OPAMP_REF: Op amp reference**
 This bit determines whether the op amp noninverting input connects to the OPAMPP pin or to the internally-derived 1/2 supply $(AVDD + AVSS) / 2$.
 0 = Noninverting input connected to the OPAMPP pin (default)
 1 = Noninverting input connected to $(AVDD + AVSS) / 2$
- Bit 2** **PD_OPAMP: Power-down op amp**
 This bit determines the power-down reference buffer state.
 0 = Power-down op amp (default)
 1 = Enable op amp
- Bits[1:0]** **Must be set to '0'**

FAULT: Fault Detect Control Register

Address = 04h

BIT 7	BIT 6	BIT 5	BIT 4	BIT 3	BIT 2	BIT 1	BIT 0
COMP_TH2	COMP_TH1	COMP_TH0	0	0	0	0	0

This register configures the fault detection operation.

Bits[7:5] COMP_TH[2:0]: Fault detect comparator threshold

These bits determine the fault detect comparator threshold level setting. See the [Fault Detection](#) section for a detailed description.

Comparator positive-side threshold

000 = 95% (default)
 001 = 92.5%
 010 = 90%
 011 = 87.5%
 100 = 85%
 101 = 80%
 110 = 75%
 111 = 70%

Comparator negative-side threshold

000 = 5% (default)
 001 = 7.5%
 010 = 10%
 011 = 12.5%
 100 = 15%
 101 = 20%
 110 = 25%
 111 = 30%

Bits[4:0] Must be set to '0'

CHnSET: Individual Channel Settings (n = 1 to 8)

Address = 05h to 0Ch

BIT 7	BIT 6	BIT 5	BIT 4	BIT 3	BIT 2	BIT 1	BIT 0
PDn	GAINn2	GAINn1	GAINn0	0	MUXn2	MUXn1	MUXn0

The CH[8:1]SET Control Register configures the power mode, PGA gain, and multiplexer setting channels. See the [Input Multiplexer](#) section for details. CH[8:2]SET are similar to CH1SET, corresponding to the respective channels (refer to [Table 6](#)).

Bit 7 **PDn: Power-down (n = individual channel number)**
 This bit determines the channel power mode for the corresponding channel.
 0 = Normal operation (default)
 1 = Channel power-down

Bits[6:4] **GAINn[2:0]: PGA gain (n = individual channel number)**
 These bits determine the PGA gain setting.
 000 = Do not use
 001 = x1
 010 = x2
 011 = Do not use
 100 = Do not use
 101 = x8
 110 = Do not use
 111 = Do not use

Bit 3 **Must be set to '0'**

Bits[2:0] **MUXn[2:0]: Channel input (n = individual channel number)**
 These bits determine the channel input selection.
 000 = Normal input (default)
 001 = Input shorted (for offset or noise measurements)
 010 = Do not use
 011 = MVDD for supply measurement
 100 = Temperature sensor
 101 = Test signal
 110 = Do not use
 111 = Do not use

FAULT_STATP: Fault Detect Positive Input Status

Address = 12h

BIT 7	BIT 6	BIT 5	BIT 4	BIT 3	BIT 2	BIT 1	BIT 0
IN8P_FAULT	IN7P_FAULT	IN6P_FAULT	IN5P_FAULT	IN4P_FAULT	IN3P_FAULT	IN2P_FAULT	IN1P_FAULT

This register stores the status of whether a fault condition is present on the positive electrode of each channel. See the [Fault Detection](#) section for details.

Bits[7:0] INnP_FAULT: Input fault status (n = individual channel number)
 0 = No fault present (default)
 1 = Fault present

FAULT_STATN: Fault Detect Negative Input Status

Address = 13h

BIT 7	BIT 6	BIT 5	BIT 4	BIT 3	BIT 2	BIT 1	BIT 0
IN8N_FAULT	IN7N_FAULT	IN6N_FAULT	IN5N_FAULT	IN4N_FAULT	IN3N_FAULT	IN2N_FAULT	IN1N_FAULT

This register stores the status of whether a fault condition is present on the negative electrode of each channel. See the [Fault Detection](#) section for details.

Bits[7:0] INnN_FAULT: Input fault status (n = individual channel number)
 0 = No fault present (default)
 1 = Fault present

GPIO: General-Purpose IO Register

Address = 14h

BIT 7	BIT 6	BIT 5	BIT 4	BIT 3	BIT 2	BIT 1	BIT 0
GPIOD4	GPIOD3	GPIOD2	GPIOD1	GPIOC4	GPIOC3	GPIOC2	GPIOC1

This register controls the action of the three GPIO pins.

Bits[7:4] GPIOD[4:1]: GPIO data
 These bits are used to read and write data to the GPIO ports. When reading the register, the data returned correspond to the state of the GPIO external pins, whether they are programmed as inputs or outputs. As outputs, a write to the GPIOD sets the output value. As inputs, a write to the GPIOD has no effect.

Bits[3:0] GPIOC[4:1]: GPIO control (corresponding to GPIOD)
 These bits determine if the corresponding GPIOD pin is an input or output.
 0 = Output
 1 = Input (default)

POWER-MONITORING SPECIFIC APPLICATIONS

All ADS130E08 channels are independently configurable, allowing any channel to be selected for voltage or current monitoring. Also, the simultaneously sampling capability of the device allows both current and voltage to be monitored at the same time. The full-scale differential input voltage of each channel is determined by the PGA gain setting (see the [CHnSET: Individual Channel Settings](#) section) for the respective channel and V_{REF} (see the [CONFIG3: Configuration Register 3](#) section). [Table 7](#) summarizes the full-scale differential input voltage range for an internal V_{REF} .

Table 7. Full-Scale Differential Input (FSDI) Voltage Summary

V_{REF}	PGA GAIN	FULL-SCALE DIFFERENTIAL INPUT VOLTAGE (V_{PP})	RMS VOLTAGE [= FSDI / ($2\sqrt{2}$)] (V_{RMS})
2.4 V	1	4.8	1.698
	2	2.4	0.849
	8	0.6	0.212
4.0 V	1	8.0	2.828
	2	4.0	1.414
	8	1	0.354

CURRENT SENSING

[Figure 41](#) shows a simplified diagram of typical configurations used for current sensing with a Rogowski coil, current transformer (CT), or an air coil that outputs a current or voltage. In the case of current-output transformers, the burden resistors (R_1) are used for current-to-voltage conversion. The burden resistor output is connected to the ADS130E08 INP and INN inputs through an antialiasing RC filter for current sensing. In the case of voltage-output transformers (such as certain types of Rogowski coils), the transformer output terminals are directly connected to the ADS130E08 INP and INN inputs through an antialiasing RC filter for current sensing. The common-mode bias voltage $(AVDD + AVSS) / 2$, can be obtained from the ADS130E08 by either configuring the internal op amp in a unity-gain configuration using the R_f resistor and setting bit 3 of [CONFIG3: Configuration Register 3](#), or it can be generated externally with a simple resistor divider network between the positive and negative supplies.

The resistor R_1 value for the current-output transformer, the output voltage (V) for the voltage-output transformer, and the turns ratio of the transformer should be carefully selected so as not to exceed the ADS130E08 FSDI range (see [Table 7](#)). Furthermore, these values should not saturate the transformer over the full operating dynamic range of the energy meter. [Figure 41a](#) shows differential input current sensing and [Figure 41b](#) shows single-ended input sensing.

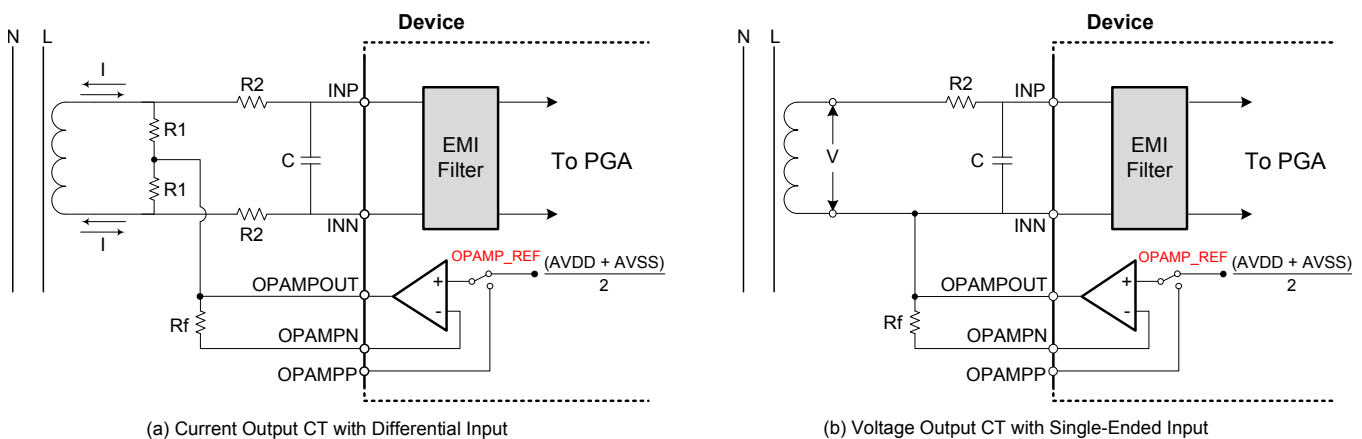

Figure 41. Simplified Current-Sensing Connections

VOLTAGE SENSING

Figure 42 shows a simplified diagram of commonly-used differential and single-ended methods of voltage sensing. A resistor divider network is used to step down the line voltage within the acceptable input range of the ADS130E08 and then directly connect to the inputs (INP and INN) through an antialiasing RC filter formed by resistor R3 and capacitor C. The common-mode bias voltage ($AVDD + AVSS$) / 2, can be obtained from the ADS130E08 by either configuring the internal op amp in a unity-gain configuration using the R_F resistor and setting bit 3 of *CONFIG3: Configuration Register 3*, or it can be generated externally by using a simple resistor divider network between the positive and negative supplies.

In either case presented in Figure 42 (Figure 42a for a differential input and Figure 42b for a single-ended input), the line voltage is divided down by a factor of $[R2 / (R1 + R2)]$. R1 and R2 values must be carefully chosen so that the voltage across the ADS130E08 inputs (INP and INN) does not exceed the ADS130E08 FSDI range (see Table 7) over the full operating dynamic range of the energy meter.

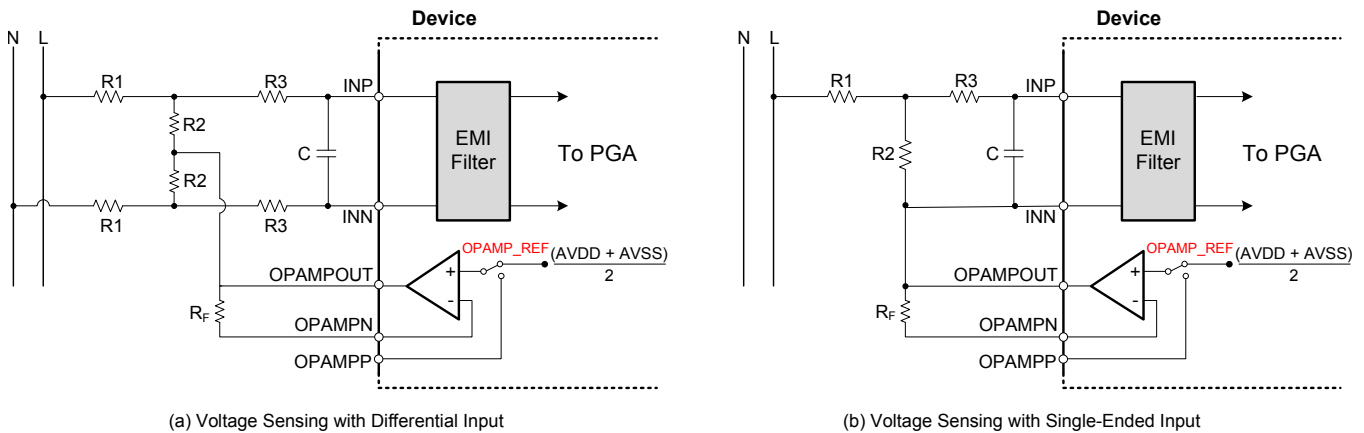
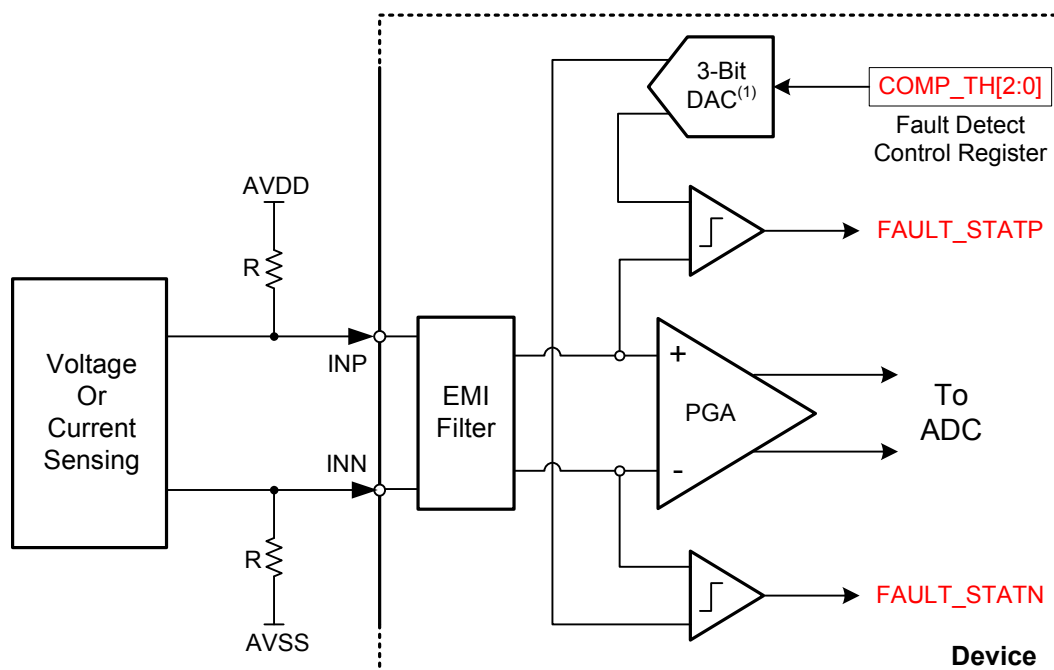

Figure 42. Simplified Voltage Sensing Connections

FAULT DETECTION

The ADS130E08 has integrated comparators that can be used in conjunction with the external pull-up or pull-down resistors (R) to detect various fault conditions. The basic principle is to compare the input voltage with the voltage set by the 3-bit DAC fault comparator, as shown in Figure 43. The comparator trigger threshold level is set by the COMP_TH[2:0] bits in the FAULT register. Assuming that the ADS130E08 is powered from a ± 2.5 -V supply and COMP_TH[2:0] = 000 (95% and 5%), the high-side trigger threshold is set at +2.25 V [equal to AVSS + (AVDD + AVSS) \times 95%] and the low-side threshold is set at -2.25 V [equal to AVSS + (AVDD + AVSS) \times 5%]. The threshold calculation formula applies to unipolar as well as bipolar supplies.

A fault condition, such as an input signal going out of a predetermined range, can be detected by setting the appropriate threshold level using the COMP_TH[2:0] bits. An open-circuit fault at the INP or INN pin can be detected by using the external pull-up and pull-down resistors, which rails the corresponding input when the input circuit breaks, causing the fault comparators to trip. To pinpoint which of the inputs is out of range, the status of the FAULT_STATP and FAULT_STATN registers can be read, which is available as part of the output data stream; see the *Data Output (DOUT)* subsection of the *SPI Interface* section.



(1) The configurable 3-bit DAC is common to all channels.

Figure 43. Fault Detect Comparators

QUICK-START GUIDE

PCB LAYOUT

Power Supplies and Grounding

The ADS130E08 has three supplies: AVDD, AVDD1, and DVDD. Both AVDD and AVDD1 should be as quiet as possible. AVDD1 provides the supply to the charge pump block and has transients at f_{CLK} . Therefore, AVDD1 and AVSS1 are recommended to be star-connected to AVDD and AVSS. It is important to eliminate noise from AVDD and AVDD1 that is non-synchronous with the ADS130E08 operation. Each ADS130E08 supply should be bypassed with 10- μ F and a 0.1- μ F solid ceramic capacitors. It is recommended that placement of the digital circuits (such as DSPs, microcontrollers, and FPGAs) in the system be done such that the return currents on those devices do not cross the ADS130E08 analog return path. The ADS130E08 can be powered from unipolar or bipolar supplies.

The capacitors used for decoupling can be surface-mount, low-cost, low-profile multilayer ceramic capacitors. In most cases the VCAP1 capacitor can also be a multilayer ceramic. However, in systems where the board is subjected to high- or low-frequency vibration, it is recommend that a non-ferroelectric capacitor such as a tantalum or class 1 capacitor (C0G or NPO for example) be installed. EIA class 2 and class 3 dielectrics (such as X7R, X5R, and X8R) are ferroelectric. The piezoelectric property of these capacitors can appear as electrical noise coming from the capacitor. When using the internal reference, noise on the VCAP1 node results in performance degradation.

Connecting the Device to Unipolar (+3 V or +1.8 V) Supplies

Figure 44 shows the ADS130E08 connected to a unipolar supply. In this example, the analog supply (AVDD) is referenced to analog ground (AVSS) and the digital supplies (DVDD) are referenced to digital ground (DGND).

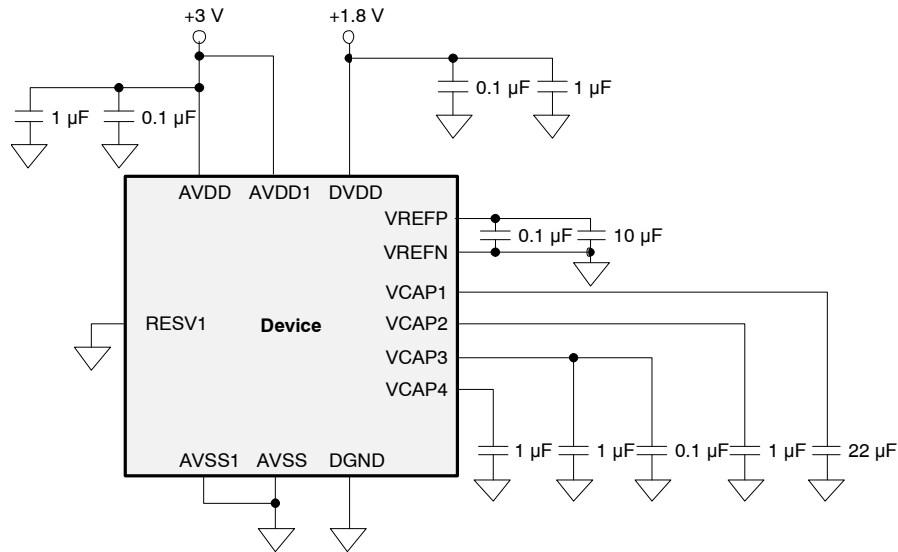

NOTE: Place the capacitors for supply, reference, and VCAP1 to VCAP4 as close to the package as possible.

Figure 44. Single-Supply Operation

Connecting the Device to Bipolar (± 1.5 V or 1.8 V) Supplies

Figure 45 illustrates the ADS130E08 connected to a bipolar supply. In this example, the analog supplies connect to the device analog supply (AVDD). This supply is referenced to the device analog return (AVSS), and the digital supply (DVDD) is referenced to the device digital ground return (DGND).

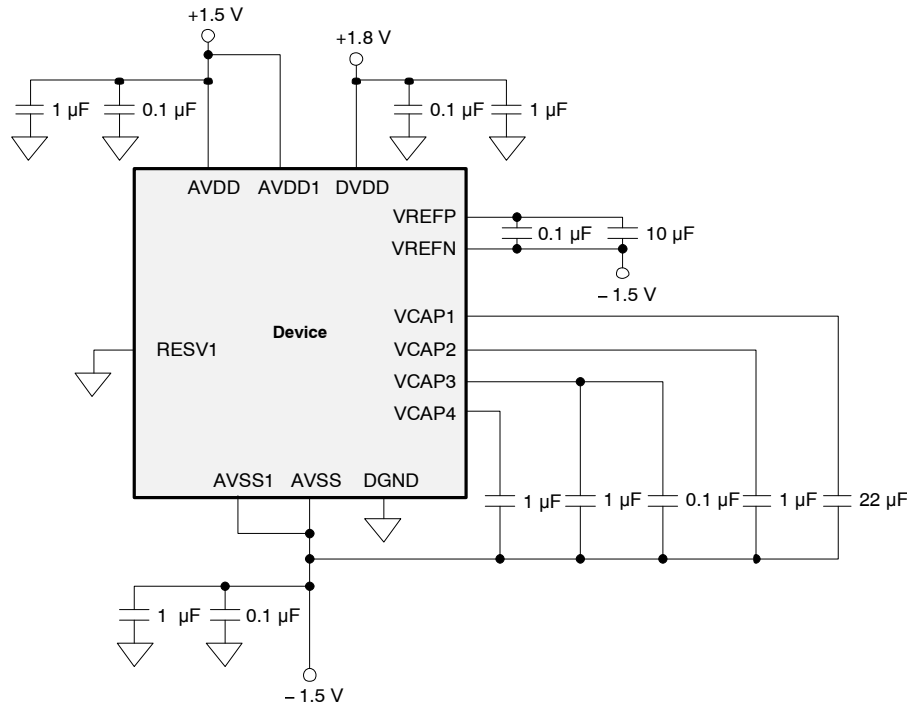

NOTE: Place the capacitors for supply, reference, and VCAP1 to VCAP4 as close to the package as possible.

Figure 45. Bipolar Supply Operation

Shielding Analog Signal Paths

As with any precision circuit, careful PCB layout ensures the best performance. It is essential to make short, direct interconnections and avoid stray wiring capacitance—particularly at the analog input pins and AVSS. These analog input pins are high-impedance and extremely sensitive to extraneous noise. The AVSS pin should be treated as a sensitive analog signal and connected directly to the supply ground with proper shielding. Leakage currents between the PCB traces can exceed the ADS130E08 input bias current if shielding is not implemented. Digital signals should be kept as far as possible from the analog input signals on the PCB.

POWER-UP SEQUENCING

Before device power-up, all digital and analog inputs must be low. At the time of power-up, all of these signals should remain low until the power supplies have stabilized, as shown in [Figure 46](#). At this time, begin supplying the master clock signal to the CLK pin. Wait for time t_{POR} , then transmit a RESET pulse. After releasing RESET, the configuration register must be programmed (see the [CONFIG1: Configuration Register 1](#) subsection of the [Register Map](#) section for details). The power-up sequence timing is shown in [Table 8](#).

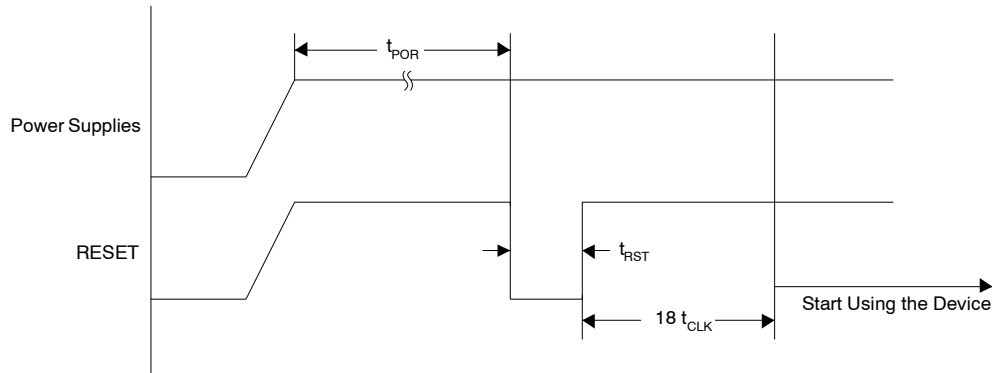

Figure 46. Power-Up Timing Diagram

Table 8. Power-Up Sequence Timing

SYMBOL	DESCRIPTION	MIN	TYP	MAX	UNIT
t_{POR}	Wait after power-up until reset	2^{16}			t_{CLK}
t_{RST}	Reset low width	2			t_{CLK}

SETTING THE DEVICE FOR BASIC DATA CAPTURE

This section outlines the procedure to configure the device in a basic state and capture data. This procedure is intended to put the device in a data sheet condition to check if the device is working properly in the user system. This procedure is recommended to be followed initially to get familiar with the device settings. When this procedure is verified, the device can be configured as needed. For details on the timings for commands refer to the appropriate sections in the data sheet. The flow chart of [Figure 47](#) details the initial configuration and setup of the ADS130E08.

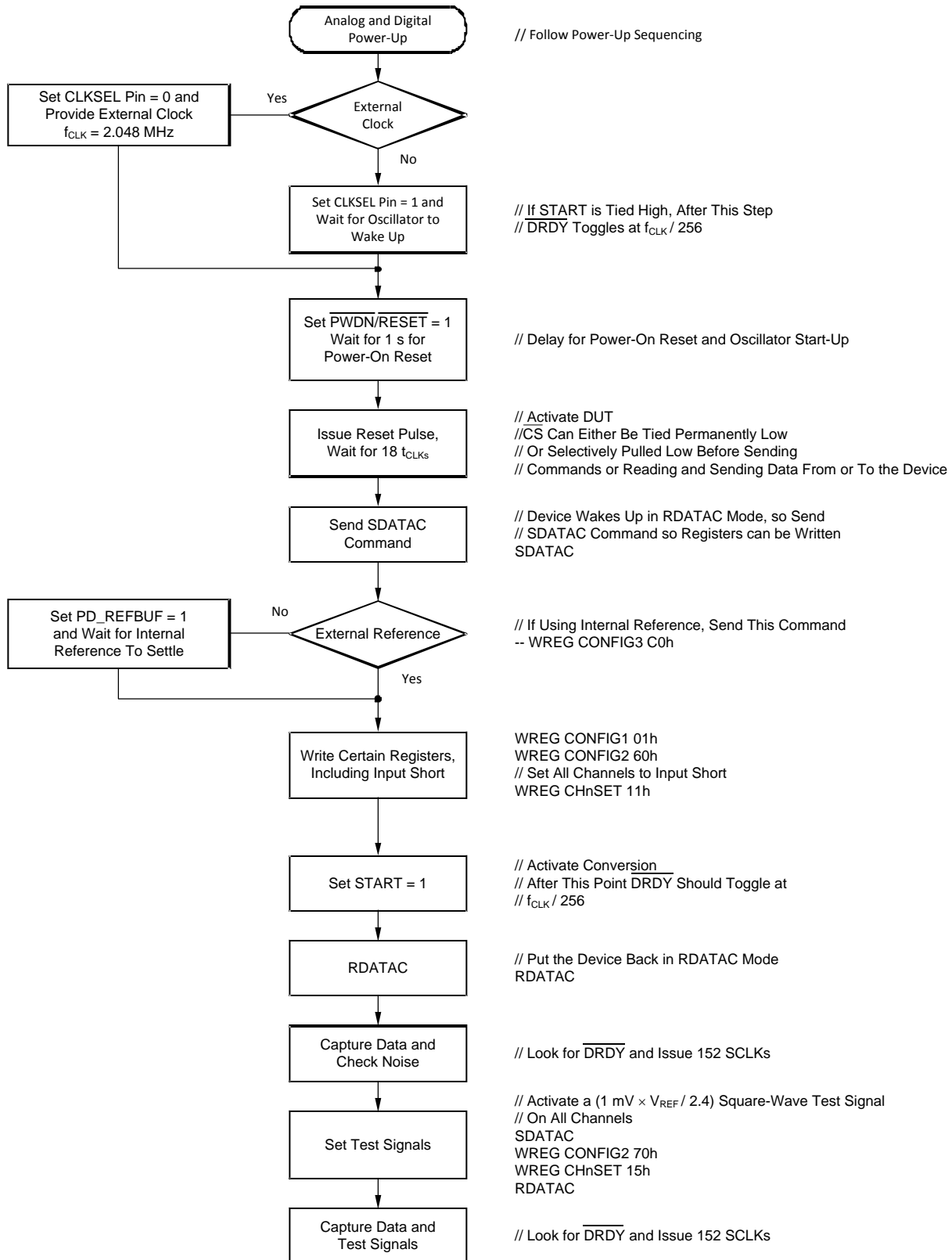

Figure 47. Initial Flow at Power-Up

REVISION HISTORY

NOTE: Page numbers for previous revisions may differ from page numbers in the current version.

Changes from Original (July 2012) to Revision A	Page
• Changed pin out drawing	7
• Added CLKSEL row to Pin Assignments table	7
• Deleted terminal 52 from DGND row in Pin Assignments table	7
• Added cross-reference to Figure 29 in second paragraph of <i>Data Ready</i> section	23
• Changed description of GPIO pin connections in <i>GPIO</i> section	23
• Deleted last sentence in description paragraph in <i>FAULT_STATP</i> and <i>FAULT_STATN</i> sections	38
• Changed Bits[1:0] to Bits[3:0] in GPIOC description in the <i>GPIO: General-Purpose IO Register</i> section	38

PACKAGING INFORMATION

Orderable Device	Status (1)	Package Type	Package Drawing	Pins	Package Qty	Eco Plan (2)	Lead finish/ Ball material (6)	MSL Peak Temp (3)	Op Temp (°C)	Device Marking (4/5)	Samples
ADS130E08IPAG	ACTIVE	TQFP	PAG	64	160	RoHS & Green	NIPDAU	Level-3-260C-168 HR	-40 to 105	ADS130E08	Samples
ADS130E08IPAGR	ACTIVE	TQFP	PAG	64	1500	RoHS & Green	NIPDAU	Level-3-260C-168 HR	-40 to 105	ADS130E08	Samples

(1) The marketing status values are defined as follows:

ACTIVE: Product device recommended for new designs.

LIFEBUY: TI has announced that the device will be discontinued, and a lifetime-buy period is in effect.

NRND: Not recommended for new designs. Device is in production to support existing customers, but TI does not recommend using this part in a new design.

PREVIEW: Device has been announced but is not in production. Samples may or may not be available.

OBsolete: TI has discontinued the production of the device.

(2) **RoHS:** TI defines "RoHS" to mean semiconductor products that are compliant with the current EU RoHS requirements for all 10 RoHS substances, including the requirement that RoHS substance do not exceed 0.1% by weight in homogeneous materials. Where designed to be soldered at high temperatures, "RoHS" products are suitable for use in specified lead-free processes. TI may reference these types of products as "Pb-Free".

RoHS Exempt: TI defines "RoHS Exempt" to mean products that contain lead but are compliant with EU RoHS pursuant to a specific EU RoHS exemption.

Green: TI defines "Green" to mean the content of Chlorine (Cl) and Bromine (Br) based flame retardants meet JS709B low halogen requirements of <=1000ppm threshold. Antimony trioxide based flame retardants must also meet the <=1000ppm threshold requirement.

(3) MSL, Peak Temp. - The Moisture Sensitivity Level rating according to the JEDEC industry standard classifications, and peak solder temperature.

(4) There may be additional marking, which relates to the logo, the lot trace code information, or the environmental category on the device.

(5) Multiple Device Markings will be inside parentheses. Only one Device Marking contained in parentheses and separated by a "~" will appear on a device. If a line is indented then it is a continuation of the previous line and the two combined represent the entire Device Marking for that device.

(6) Lead finish/Ball material - Orderable Devices may have multiple material finish options. Finish options are separated by a vertical ruled line. Lead finish/Ball material values may wrap to two lines if the finish value exceeds the maximum column width.

Important Information and Disclaimer:The information provided on this page represents TI's knowledge and belief as of the date that it is provided. TI bases its knowledge and belief on information provided by third parties, and makes no representation or warranty as to the accuracy of such information. Efforts are underway to better integrate information from third parties. TI has taken and continues to take reasonable steps to provide representative and accurate information but may not have conducted destructive testing or chemical analysis on incoming materials and chemicals. TI and TI suppliers consider certain information to be proprietary, and thus CAS numbers and other limited information may not be available for release.

In no event shall TI's liability arising out of such information exceed the total purchase price of the TI part(s) at issue in this document sold by TI to Customer on an annual basis.

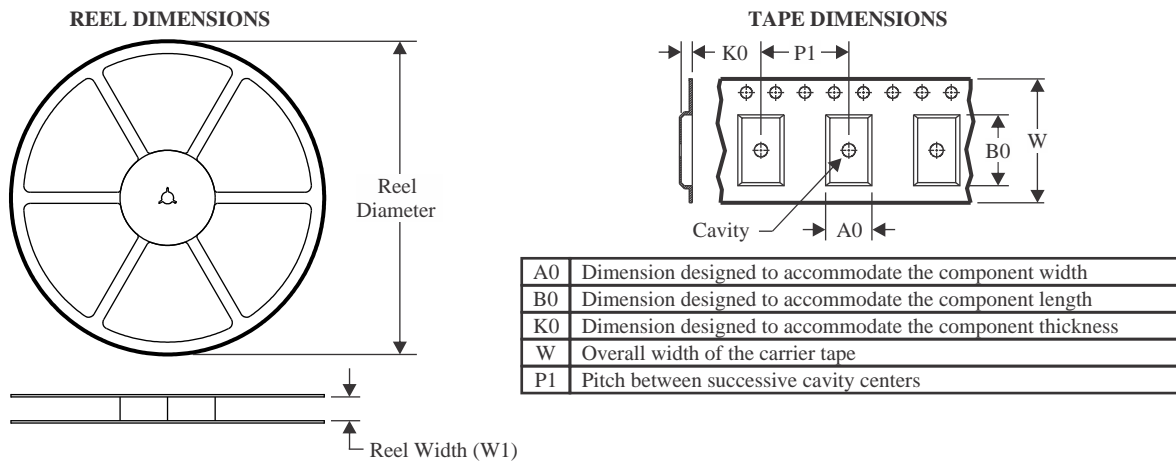
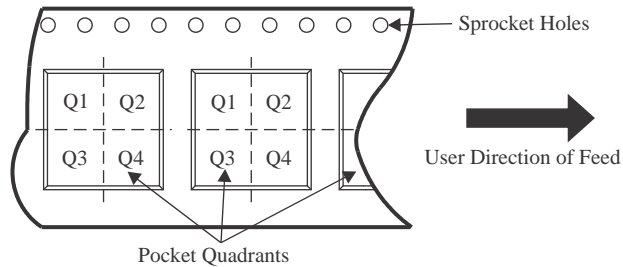
TAPE AND REEL INFORMATION

QUADRANT ASSIGNMENTS FOR PIN 1 ORIENTATION IN TAPE

*All dimensions are nominal

Device	Package Type	Package Drawing	Pins	SPQ	Reel Diameter (mm)	Reel Width W1 (mm)	A0 (mm)	B0 (mm)	K0 (mm)	P1 (mm)	W (mm)	Pin1 Quadrant
ADS130E08IPAGR	TQFP	PAG	64	1500	330.0	24.4	13.0	13.0	1.5	16.0	24.0	Q2

TAPE AND REEL BOX DIMENSIONS

*All dimensions are nominal

Device	Package Type	Package Drawing	Pins	SPQ	Length (mm)	Width (mm)	Height (mm)
ADS130E08IPAGR	TQFP	PAG	64	1500	350.0	350.0	43.0

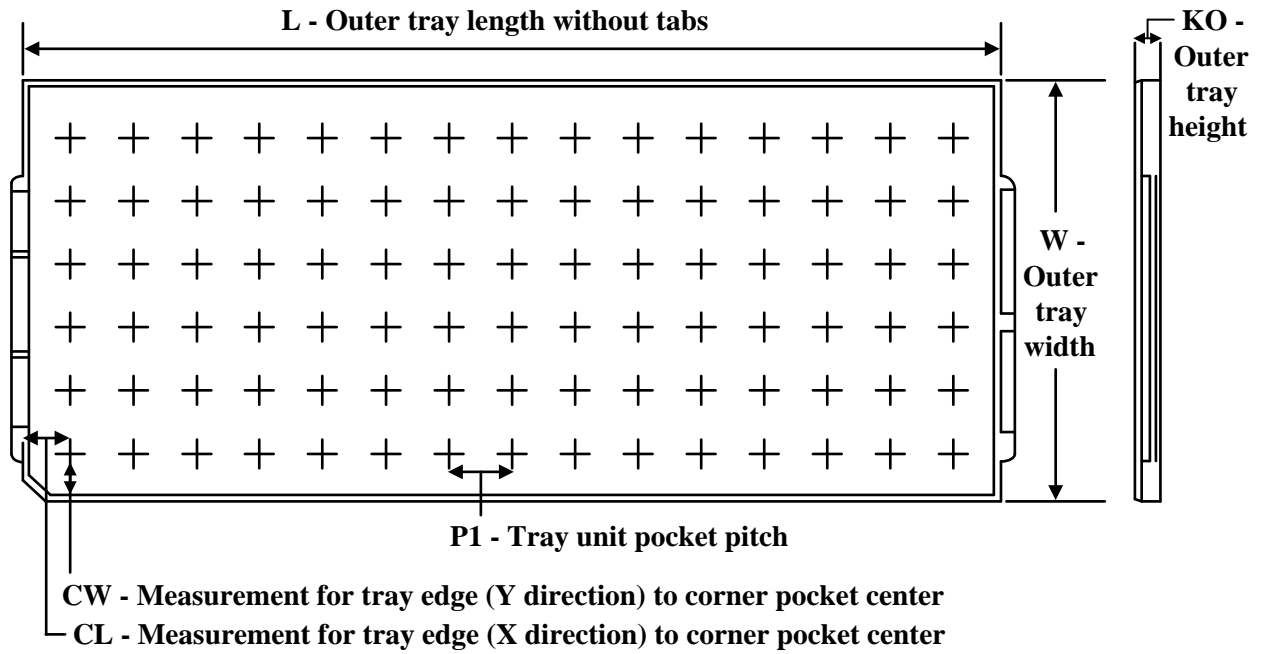
TRAY

Chamfer on Tray corner indicates Pin 1 orientation of packed units.

*All dimensions are nominal

Device	Package Name	Package Type	Pins	SPQ	Unit array matrix	Max temperature (°C)	L (mm)	W (mm)	K0 (µm)	P1 (mm)	CL (mm)	CW (mm)
ADS130E08IPAG	PAG	TQFP	64	160	8 x 20	150	315	135.9	7620	15.2	13.1	13

PAG (S-PQFP-G64)

PLASTIC QUAD FLATPACK

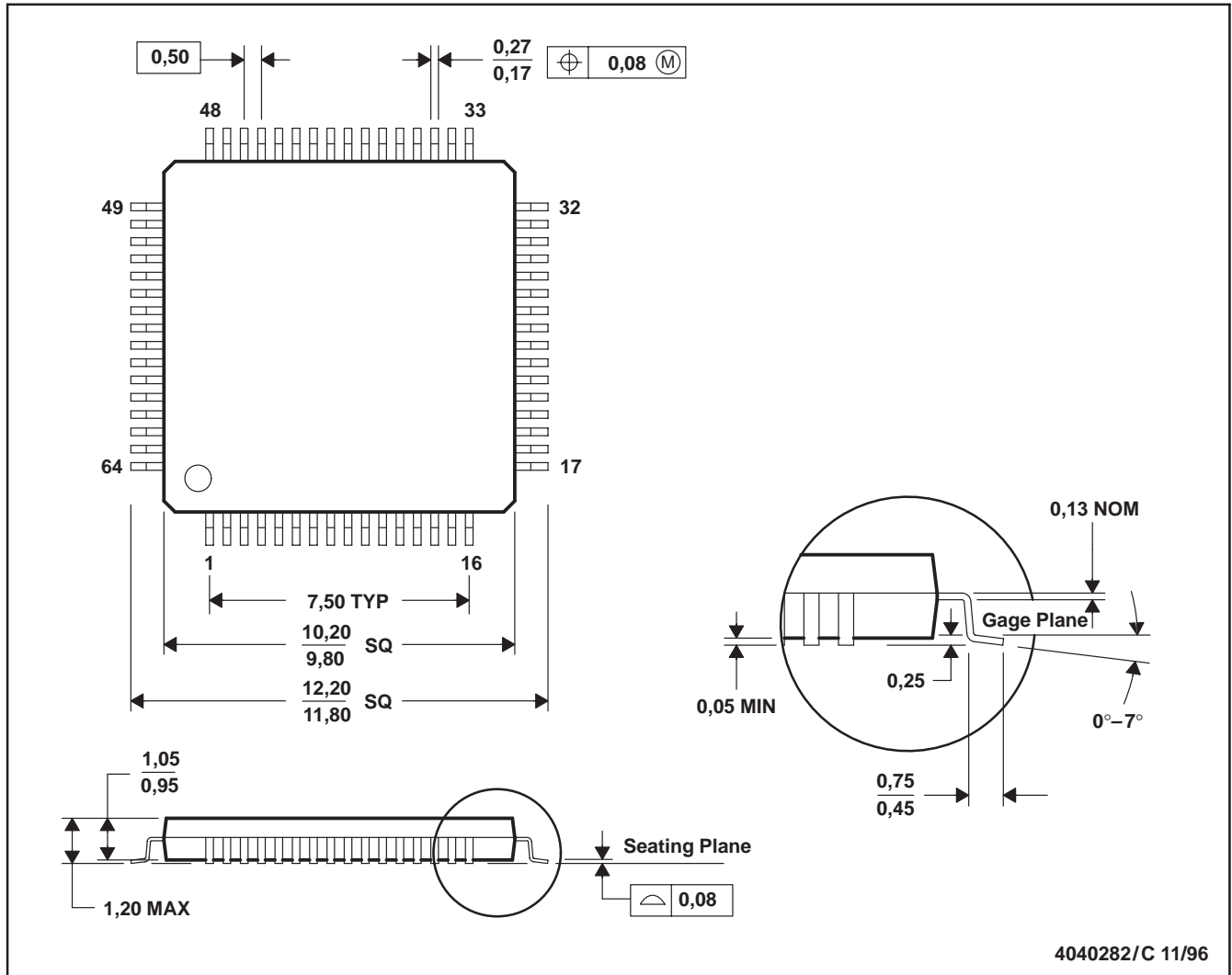

- NOTES: A. All linear dimensions are in millimeters.
 B. This drawing is subject to change without notice.
 C. Falls within JEDEC MS-026

PAG (S-PQFP-G64)

PLASTIC QUAD FLATPACK

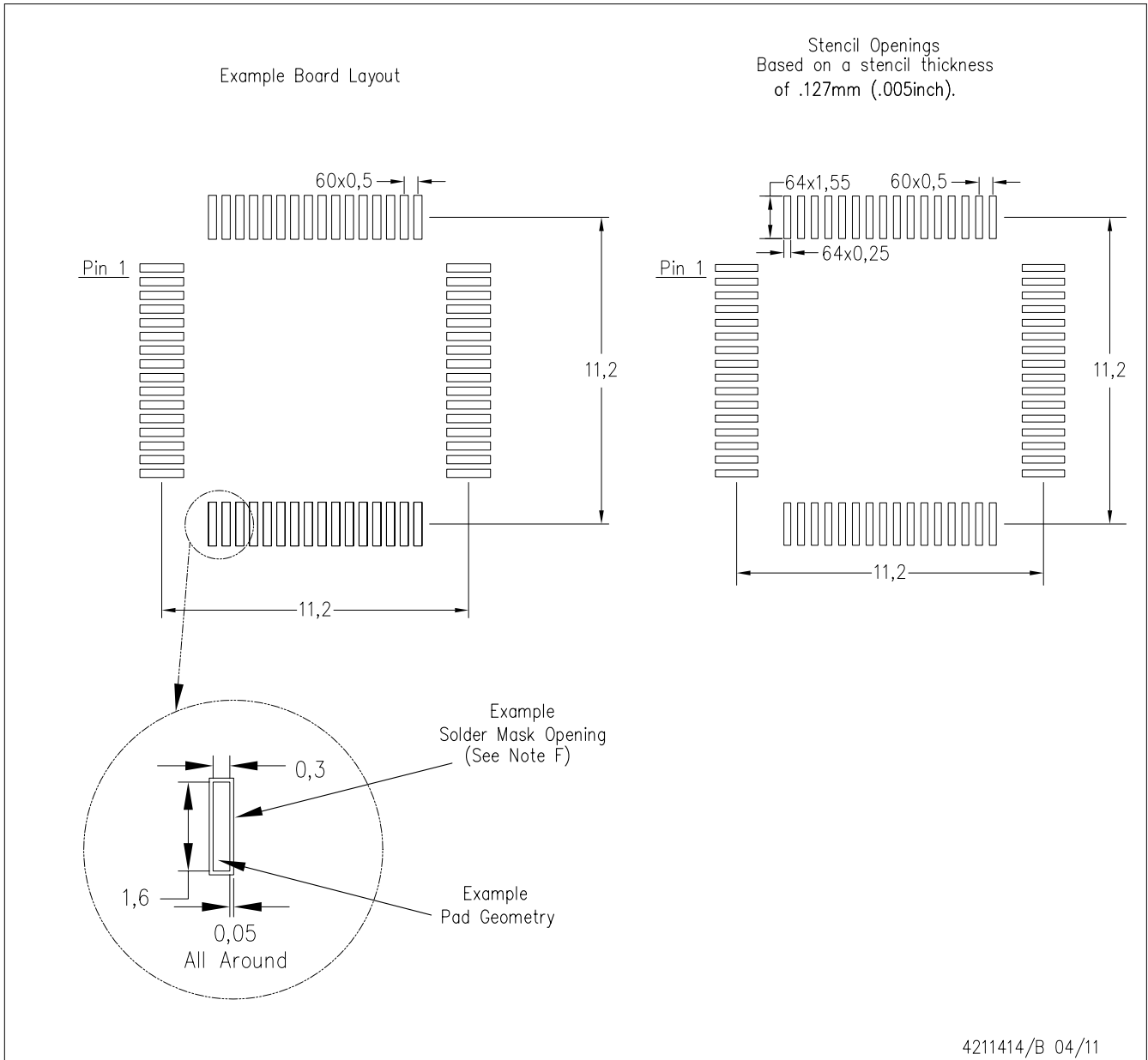

- NOTES:
- A. All linear dimensions are in millimeters.
 - B. This drawing is subject to change without notice.
 - C. Laser cutting apertures with trapezoidal walls and also rounding corners will offer better paste release. Customers should contact their board assembly site for stencil design recommendations. Example stencil design based on a 50% volumetric metal load solder paste. Refer to IPC-7525 for other stencil recommendations.
 - D. Customers should contact their board fabrication site for solder mask tolerances between and around signal pads.

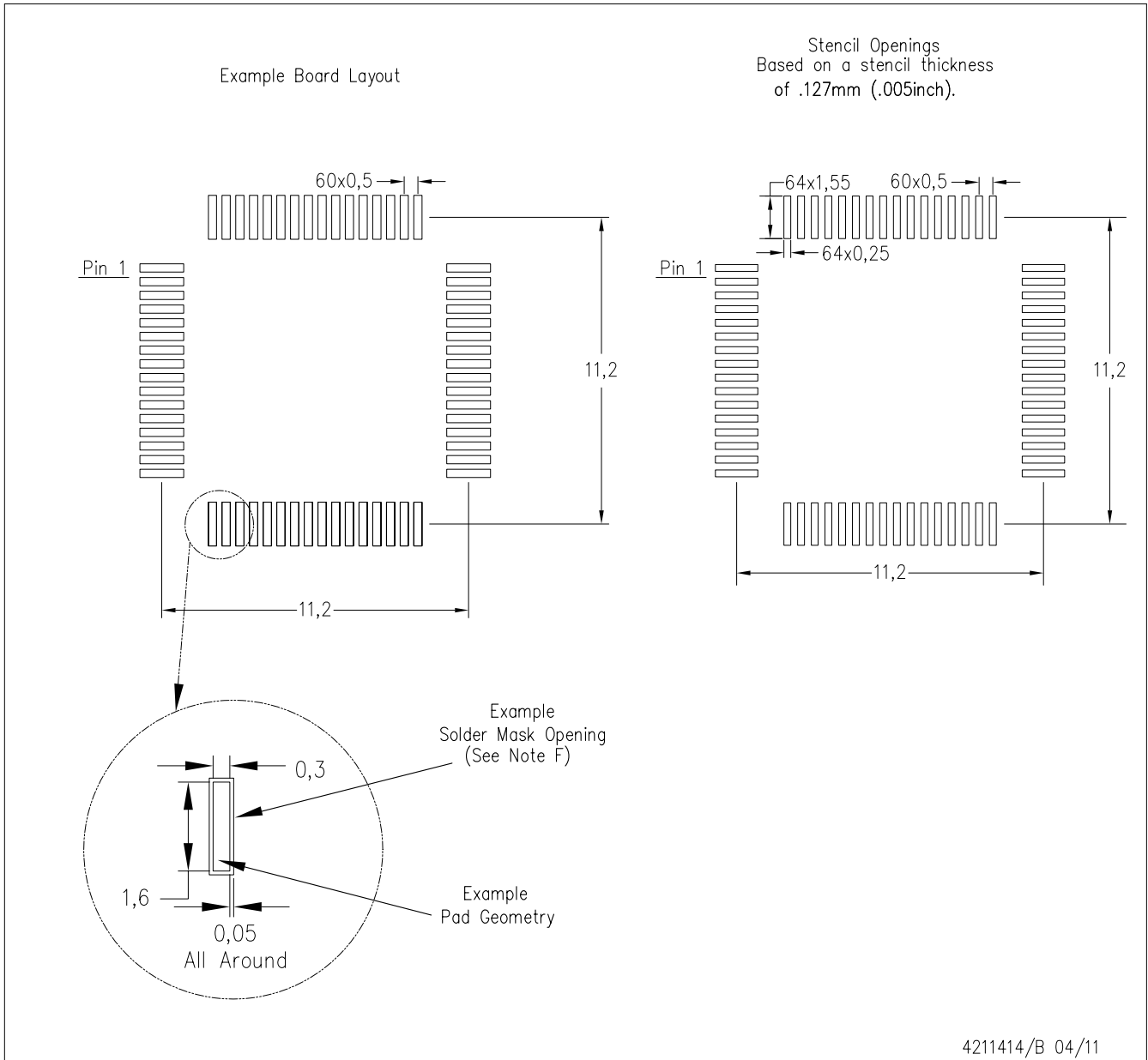

- NOTES:
- A. All linear dimensions are in millimeters.
 - B. This drawing is subject to change without notice.
 - C. Laser cutting apertures with trapezoidal walls and also rounding corners will offer better paste release. Customers should contact their board assembly site for stencil design recommendations. Example stencil design based on a 50% volumetric metal load solder paste. Refer to IPC-7525 for other stencil recommendations.
 - D. Customers should contact their board fabrication site for solder mask tolerances between and around signal pads.

IMPORTANT NOTICE AND DISCLAIMER

TI PROVIDES TECHNICAL AND RELIABILITY DATA (INCLUDING DATA SHEETS), DESIGN RESOURCES (INCLUDING REFERENCE DESIGNS), APPLICATION OR OTHER DESIGN ADVICE, WEB TOOLS, SAFETY INFORMATION, AND OTHER RESOURCES "AS IS" AND WITH ALL FAULTS, AND DISCLAIMS ALL WARRANTIES, EXPRESS AND IMPLIED, INCLUDING WITHOUT LIMITATION ANY IMPLIED WARRANTIES OF MERCHANTABILITY, FITNESS FOR A PARTICULAR PURPOSE OR NON-INFRINGEMENT OF THIRD PARTY INTELLECTUAL PROPERTY RIGHTS.

These resources are intended for skilled developers designing with TI products. You are solely responsible for (1) selecting the appropriate TI products for your application, (2) designing, validating and testing your application, and (3) ensuring your application meets applicable standards, and any other safety, security, regulatory or other requirements.

These resources are subject to change without notice. TI grants you permission to use these resources only for development of an application that uses the TI products described in the resource. Other reproduction and display of these resources is prohibited. No license is granted to any other TI intellectual property right or to any third party intellectual property right. TI disclaims responsibility for, and you will fully indemnify TI and its representatives against, any claims, damages, costs, losses, and liabilities arising out of your use of these resources.

TI's products are provided subject to [TI's Terms of Sale](#) or other applicable terms available either on ti.com or provided in conjunction with such TI products. TI's provision of these resources does not expand or otherwise alter TI's applicable warranties or warranty disclaimers for TI products.

TI objects to and rejects any additional or different terms you may have proposed.

Mailing Address: Texas Instruments, Post Office Box 655303, Dallas, Texas 75265
Copyright © 2022, Texas Instruments Incorporated

Looking for pricing, stock, or lifecycle information?

Click below to explore more details on WIN SOURCE:

 [View ADS130E08IPAGR on WIN SOURCE](#)

 [Texas Instruments](#) Information

Optimize Your Supply Chain with WIN SOURCE Solutions

-  Global Sourcing Solution
-  Obsolete Management
-  Cost Control Management
-  Shortage Management
-  Alternative Solution
-  Excess Inventory Management