

LD6806 series

Ultra low-dropout regulator, low noise, 200 mA

Rev. 3 — 9 December 2011

Product data sheet

1. Product profile

1.1 General description

The LD6806 series is a small-size Low-DropOut regulator (LDO) family with a typical voltage drop of 60 mV at 200 mA current rating.

The device is available in three different surface-mounted packages, one 0.4 mm pitch CSP, one leadless plastic package SOT886 and one gull wing package SOT753.

The operating voltage ranges from 2.3 V to 5.5 V and the output voltage ranges from 1.2 V to 3.6 V.

LD6806x/xxH devices show a high-ohmic state at the output pin, while the LD6806x/xxP contains a pull-down switching transistor, to provide a low-ohmic output stage when the device is disabled. All devices use the same regulator design and are manufactured in monolithic silicon technology.

These features make the LD6806 series ideal for use in applications requiring component miniaturization, such as mobile phone handsets, cordless telephones and personal digital devices.

1.2 Features and benefits

- Input voltage range 2.3 V to 5.5 V
- Output voltage range 1.2 V to 3.6 V
- Dropout voltage 60 mV at 200 mA output rating
- Low quiescent current in shutdown mode (typical 1.0 μ A)
- 30 μ V RMS output noise voltage (typical value) at 10 Hz to 100 kHz
- Turn-on time just 200 μ s
- 55 dB Power Supply Rejection Ratio (PSRR) at 1 kHz
- Temperature watchdog
- Current limiter
- LD6806xxxH: high-ohmic (3-state) output state when disabled
- LD6806xxxP: low-ohmic output state when disabled
- Integrated ESD protection of 10 kV Human Body Model
- WLCSP with 0.4 mm pitch and package size of 0.76 mm \times 0.76 mm \times 0.47 mm
- SOT886 leadless package 1.0 mm \times 1.45 mm \times 0.5 mm
- SOT753 plastic surface-mounted device
- Pb-free, RoHS compliant and free of Halogen and Antimony (dark green compliant)



1.3 Applications

- Analog and digital interfaces requiring lower than standard supply voltage in mobile appliances such as mobile phones, media players and so on.

2. Pinning information

2.1 Pinning

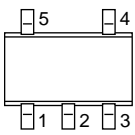

Fig 1. Configuration for SOT753

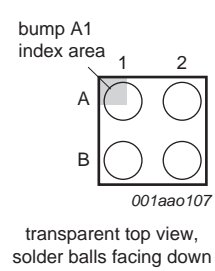

Fig 2. Configuration for WLCSP4

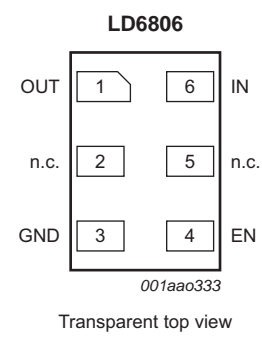

Fig 3. Configuration for SOT886

2.2 Pin description

Table 1. Pin description for SOT753

Symbol	Pin	Description
IN	1	supply voltage input
GND	2	supply ground
EN	3	device enable input; active HIGH
n.c.	4	not connected
OUT	5	regulator output voltage

Table 2. Pin description for WLCSP4

Symbol	Pin	Description
GND	A1	supply ground
EN	A2	device enable input; active HIGH
OUT	B1	regulator output voltage
IN	B2	supply voltage input

Table 3. Pin description for SOT886

Symbol	Pin	Description
OUT	1	regulator output voltage
n.c.	2	not connected
GND	3	supply ground

Table 3. Pin description for SOT886

Symbol	Pin	Description
EN	4	device enable input; active HIGH
n.c.	5	not connected
IN	6	supply voltage input

3. Ordering information

Table 4. Ordering information

Type number	Package		Version
	Name	Description	
LD6806CX4/xxx	WLCSP4	wafer level chip-size package; 4 bumps (2 × 2) ^[1]	-
LD6806CX4/C/xxx	WLCSP4	wafer level chip-size package; 4 bumps (2 × 2) with backside coating ^[1]	-
LD6806F/xxx	XSON6	plastic extremely thin small outline package; no leads; 6 terminals; body 1 × 1.45 × 0.5 mm	SOT886
LD6806TD/xxx	TSOP5	plastic surface-mounted package; 5 leads	SOT753

[1] Size 0.76 mm × 0.76 mm.

3.1 Ordering options

Further information on output voltage is available on request; see [Section 21 “Contact information”](#).

Table 5. Type number and nominal output voltage of high-ohmic output

Type number	Nominal output voltage	Type number	Nominal output voltage
LD6806[CX4, CX4/C, F, TD]/12H	1.2 V	LD6806[CX4, CX4/C, F, TD]/23H	2.3 V
LD6806[CX4, CX4/C, F, TD]/13H	1.3 V	LD6806[CX4, CX4/C, F, TD]/25H	2.5 V
LD6806[CX4, CX4/C, F, TD]/14H	1.4 V	LD6806[CX4, CX4/C, F, TD]/28H	2.8 V
LD6806[CX4, CX4/C, F, TD]/16H	1.6 V	LD6806[CX4, CX4/C, F, TD]/29H	2.9 V
LD6806[CX4, CX4/C, F, TD]/18H	1.8 V	LD6806[CX4, CX4/C, F, TD]/30H	3.0 V
LD6806[CX4, CX4/C, F, TD]/20H	2.0 V	LD6806[CX4, CX4/C, F, TD]/33H	3.3 V
LD6806[CX4, CX4/C, F, TD]/22H	2.2 V	LD6806[CX4, CX4/C, F, TD]/36H	3.6 V

Table 6. Type number and nominal output voltage of low-ohmic output

Type number	Nominal output voltage	Type number	Nominal output voltage
LD6806[CX4, CX4/C, F, TD]/12P	1.2 V	LD6806[CX4, CX4/C, F, TD]/23P	2.3 V
LD6806[CX4, CX4/C, F, TD]/13P	1.3 V	LD6806[CX4, CX4/C, F, TD]/25P	2.5 V
LD6806[CX4, CX4/C, F, TD]/14P	1.4 V	LD6806[CX4, CX4/C, F, TD]/28P	2.8 V
LD6806[CX4, CX4/C, F, TD]/16P	1.6 V	LD6806[CX4, CX4/C, F, TD]/29P	2.9 V

Table 6. Type number and nominal output voltage of low ohmic output ...continued

Type number	Nominal output voltage	Type number	Nominal output voltage
LD6806[CX4, CX4/C, F, TD]/18P	1.8 V	LD6806[CX4, CX4/C, F, TD]/30P	3.0 V
LD6806[CX4, CX4/C, F, TD]/20P	2.0 V	LD6806[CX4, CX4/C, F, TD]/33P	3.3 V
LD6806[CX4, CX4/C, F, TD]/22P	2.2 V	LD6806[CX4, CX4/C, F, TD]/36P	3.6 V

4. Block diagram

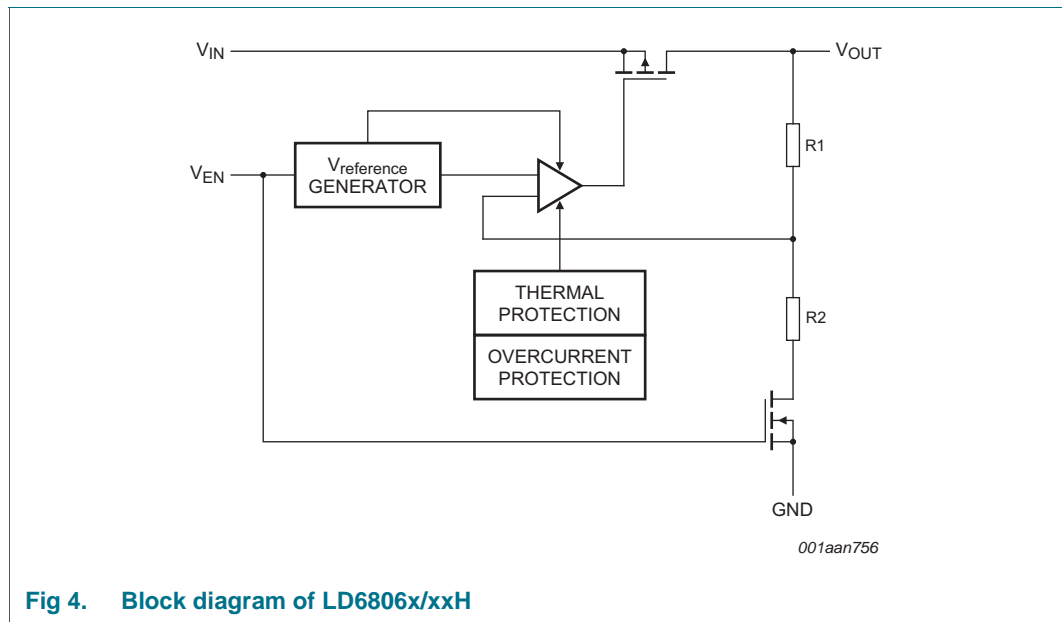

Fig 4. Block diagram of LD6806x/xxH

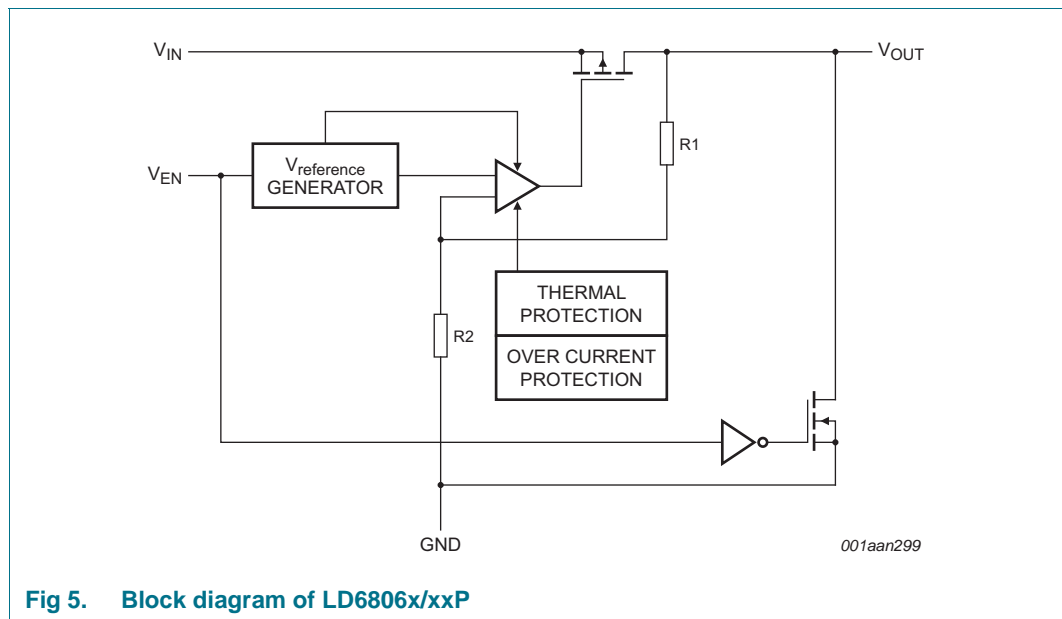

Fig 5. Block diagram of LD6806x/xxP

5. Limiting values

Table 7. Limiting values

In accordance with the Absolute Maximum Rating System (IEC 60134). Voltages are referenced to GND (ground = 0 V).

Symbol	Parameter	Conditions	Min	Max	Unit	
V_{IN}	voltage on pin IN	4 ms transient	-0.5	+6.0	V	
P_{tot}	total power dissipation	LD6806CX4/xxx, LD6806CX4/Cxxx	[1]	-	770	mW
		LD6806F/xxx	[1]	-	450	mW
		LD6806TD/xxx	[1]	-	800	mW
T_{stg}	storage temperature		-55	+150	°C	
T_j	junction temperature		-40	+125	°C	
T_{amb}	ambient temperature		-40	+85	°C	
V_{ESD}	electrostatic discharge voltage	human body model level 6	[2]		±10	kV
		machine model class 3	[3]	-	±400	V

[1] The (absolute) maximum power dissipation depends on the junction temperature T_j . Higher power dissipation is allowed with lower ambient temperatures. The conditions to determine the specified values are $T_{amb} = 25\text{ °C}$ and the use of a two layer PCB.

[2] According to IEC 61340-3-1.

[3] According to JESD22-A115C.

6. Recommended operating conditions

Table 8. Operating conditions

Voltages are referenced to GND (ground = 0 V).

Symbol	Parameter	Conditions	Min	Max	Unit
T_{amb}	ambient temperature		-40	+85	°C
T_j	junction temperature		-	+125	°C
Pin IN					
V_{IN}	voltage on pin IN		2.3	5.5	V
Pin EN					
V_{EN}	voltage on pin EN		0	V_{IN}	V
Pin OUT					
$C_{L(ext)}$	external load capacitance		[1] 1.0	-	μF

[1] See [Section 10.1 "Output capacitor values"](#).

7. Thermal characteristics

Table 9. Thermal characteristics

Symbol	Parameter	Conditions	Typ	Unit
$R_{th(j-a)}$	thermal resistance from junction to ambient	LD6806CX4/xxx, LD6806CX4/Cxxx	[1][2] 130	K/W
		LD6806F/xxx	[1][2] 220	K/W
		LD6806TD/xxx	[1][2] 125	K/W

- [1] The overall $R_{th(j-a)}$ can vary depending on the board layout. To minimize the effective $R_{th(j-a)}$, all pins must have a solid connection to larger Cu layer areas for example to the power and ground layer. In multi-layer PCB applications, the second layer should be used to create a large heat spreader area directly below the LDO. If this layer is either ground or power, it should be connected with several vias to the top layer connecting to the device ground or supply. Avoid the use of solder-stop varnish under the chip.
- [2] Use the measurement data given for a rough estimation of the $R_{th(j-a)}$ in your application. The actual $R_{th(j-a)}$ value can vary in applications using different layer stacks and layouts.

8. Characteristics

Table 10. Electrical characteristics

At recommended input voltages and $T_{amb} = -40\text{ °C}$ to $+85\text{ °C}$; voltages are referenced to GND (ground = 0 V); unless otherwise specified.

Symbol	Parameter	Conditions	Min	Typ	Max	Unit	
ΔV_O	output voltage variation	$V_{OUT} < 1.8\text{ V}$; $I_{OUT} = 1\text{ mA}$					
		$T_{amb} = +25\text{ °C}$	-3	± 0.5	+3	%	
		$-30\text{ °C} \leq T_{amb} \leq +85\text{ °C}$	-4	-	+4	%	
		$V_{OUT} \geq 1.8\text{ V}$; $I_{OUT} = 1\text{ mA}$					
		$T_{amb} = +25\text{ °C}$	-2	± 0.5	+2	%	
		$-30\text{ °C} \leq T_{amb} \leq +85\text{ °C}$	-3	-	+3	%	
Line regulation error							
$\Delta V_O / (V_O \times \Delta V_I)$	relative output voltage variation with input voltage	$V_{IN} = (V_{O(nom)} + 0.2\text{ V})$ to 5.5 V	[1]	-0.1	-	+0.1 %/V	
Load regulation error							
$\Delta V_O / (V_O \times \Delta I_O)$	relative output voltage variation with output current	$1\text{ mA} \leq I_{OUT} \leq 200\text{ mA}$					
		LD6806CX4/xxx, LD6806CX4/Cxxx	-	0.0025	0.01	%/mA	
		LD6806F/xxx, LD6806TD/xxx	-	0.005	0.02	%/mA	
V_{do}	dropout voltage	$I_{OUT} = 200\text{ mA}$; $V_{IN} > V_{O(nom)}$	[1]				
		LD6806CX4/xxx, LD6806CX4/Cxxx	-	60	100	mV	
		LD6806F/xxx, LD6806TD/xxx	-	80	130	mV	
V_{IL}	LOW-level input voltage	pin EN	0	-	0.4	V	
V_{IH}	HIGH-level input voltage	pin EN	1.4	-	5.5	V	
I_{OUT}	current on pin OUT		-	-	200	mA	
I_{OM}	peak output current	$V_{IN} = (V_{O(nom)} + 0.2\text{ V})$ to 5.5 V	[1]				
		$V_{O(nom)} > 1.8\text{ V}$; $V_{OUT} = 0.95 \times V_{O(nom)}$		300	-	-	mA
		$V_{O(nom)} < 1.8\text{ V}$; $V_{OUT} = 0.9 \times V_{O(nom)}$		300	-	-	mA

Table 10. Electrical characteristics ...continued

At recommended input voltages and $T_{amb} = -40\text{ °C}$ to $+85\text{ °C}$; voltages are referenced to GND (ground = 0 V); unless otherwise specified.

Symbol	Parameter	Conditions	Min	Typ	Max	Unit
I_{sc}	short-circuit current	pin OUT	-	600	-	mA
I_q	quiescent current	$V_{EN} = 1.4\text{ V}$; $I_{OUT} = 0\text{ mA}$	-	70	100	μA
		$V_{EN} = 1.4\text{ V}$; $1\text{ mA} \leq I_{OUT} \leq 200\text{ mA}$	-	155	250	μA
		$V_{EN} \leq 0.4\text{ V}$	-	0.1	1.0	μA
T_{sd}	shutdown temperature		-	160	-	$^{\circ}\text{C}$
$T_{sd(hys)}$	shutdown temperature hysteresis		[2]	-	20	$^{\circ}\text{K}$
PSRR	power supply rejection ratio	$V_{IN} = V_{O(nom)} + 1\text{ V}$; $I_{OUT} = 30\text{ mA}$; $f_{ripple} = 1\text{ kHz}$	[1]	-	-55	dB
$V_{n(o)(RMS)}$	RMS output noise voltage	bandwidth = 10 Hz to 100 kHz; $C_{L(ext)} = 1\text{ }\mu\text{F}$	-	30	-	μV
$t_{startup(reg)}$	regulator start-up time	$V_{IN} = 5.5\text{ V}$; $V_{OUT} = 0.95 \times V_{O(nom)}$; $I_{OUT} = 200\text{ mA}$; $C_{L(ext)} = 1\text{ }\mu\text{F}$	[1]	-	-	200 μs
$t_{sd(reg)}$	regulator shutdown time	$V_{IN} = 5.5\text{ V}$; $C_{L(ext)} = 1\text{ }\mu\text{F}$	[3]	-	300	μs
R_{pd}	pull-down resistance		[3]	-	100	Ω

[1] $V_{O(nom)}$ = nominal output voltage (device specific).

[2] The junction temperature must decrease by $T_{sd(hys)}$ to enable the device after T_{sd} was reached and the device was disabled.

[3] LD6806x/xxP only.

9. Dynamic behavior

All results described in [Section 9](#) are based on measurements of types LD6806CX4xxx and LD6806Fxxx from the LD6806 product series within [Section 6 "Recommended operating conditions"](#).

9.1 Dropout

The dropout voltage is defined as the smallest input to output voltage difference at a specified load current when the regulator operates within its linear region with the pass transistor functioning as a plain resistor. This means that the input voltage is below the nominal output voltage value.

A small dropout voltage guaranties lower power consumption and efficiency maximization.

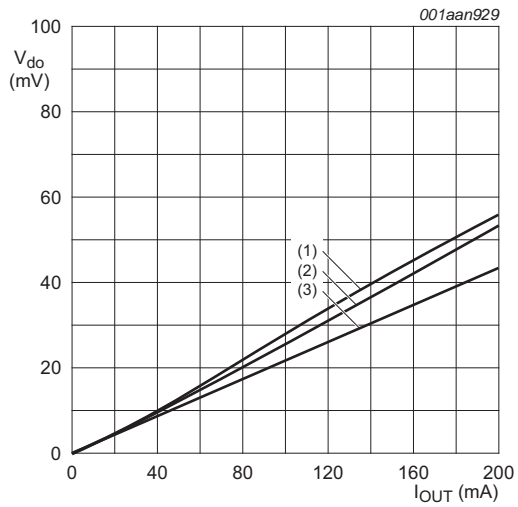

- (1) +85 °C
- (2) +25 °C
- (3) -40 °C

Fig 6. Dropout as a function of temperature for LD6806CX4/25H

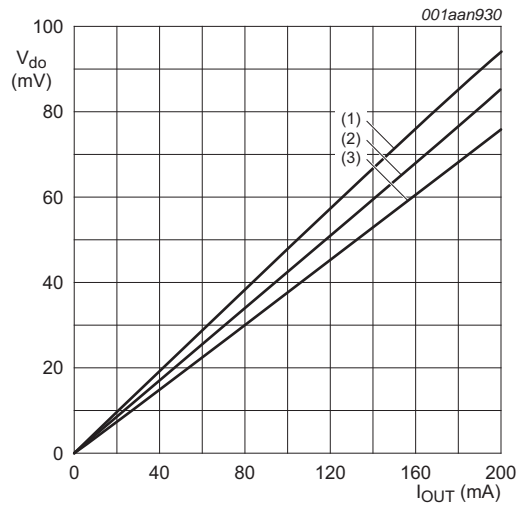

- (1) +85 °C
- (2) +25 °C
- (3) -40 °C

Fig 7. Dropout as a function of temperature for LD6806F/25H

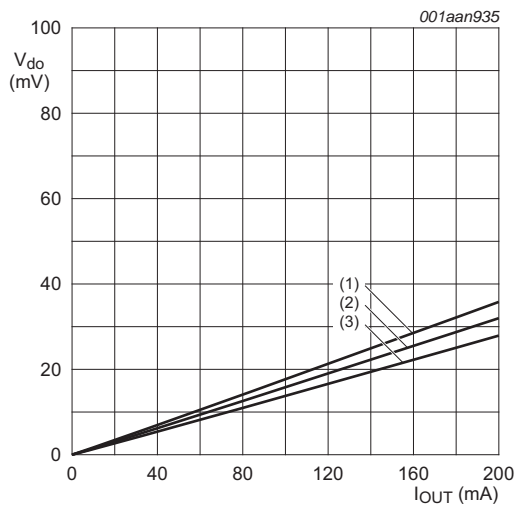

- (1) +85 °C
- (2) +25 °C
- (3) -40 °C

Fig 8. Dropout as a function of temperature for LD6806CX4/36H

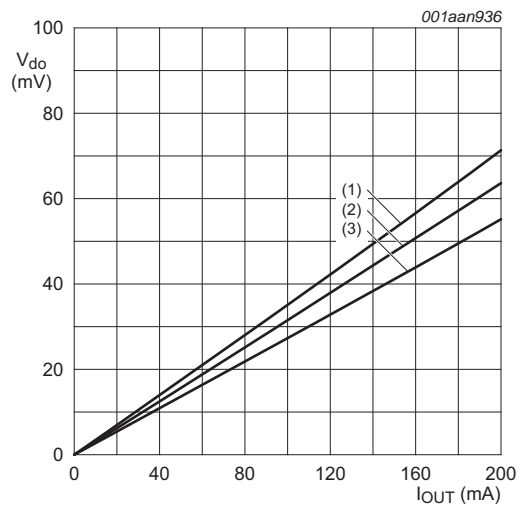

- (1) +85 °C
- (2) +25 °C
- (3) -40 °C

Fig 9. Dropout as a function of temperature for LD6806F/36H

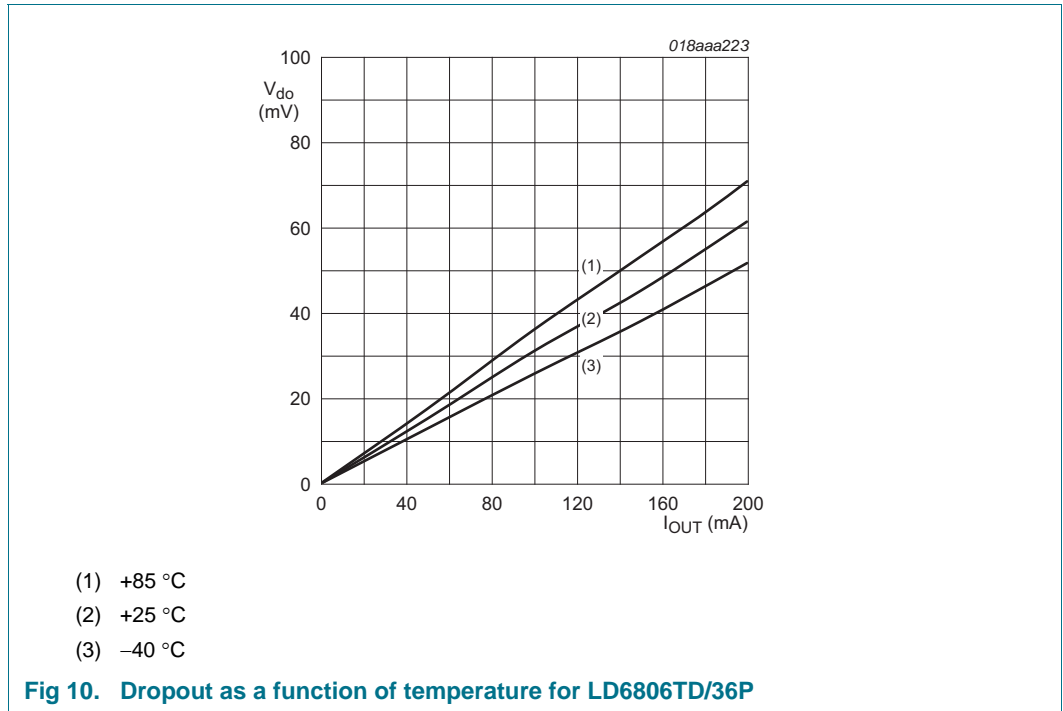

9.2 Output voltage variation

The guaranteed output voltages are specified in [Table 10](#).

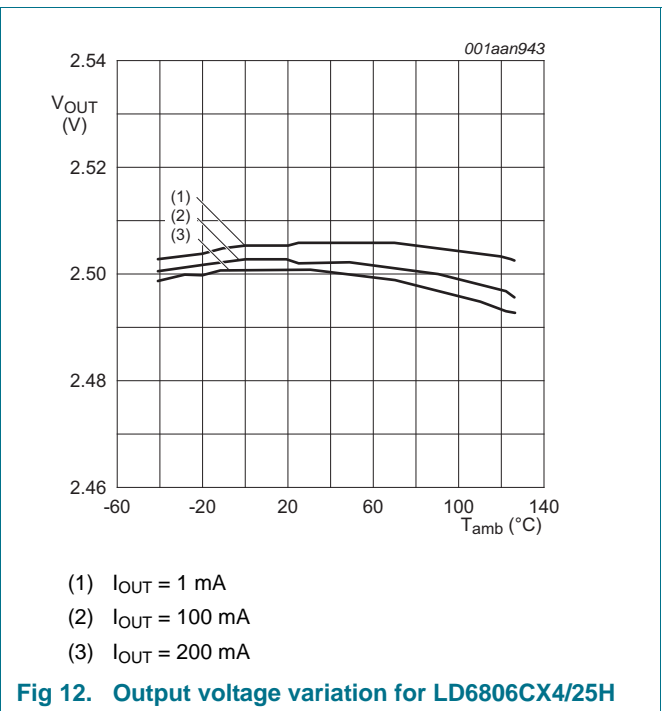
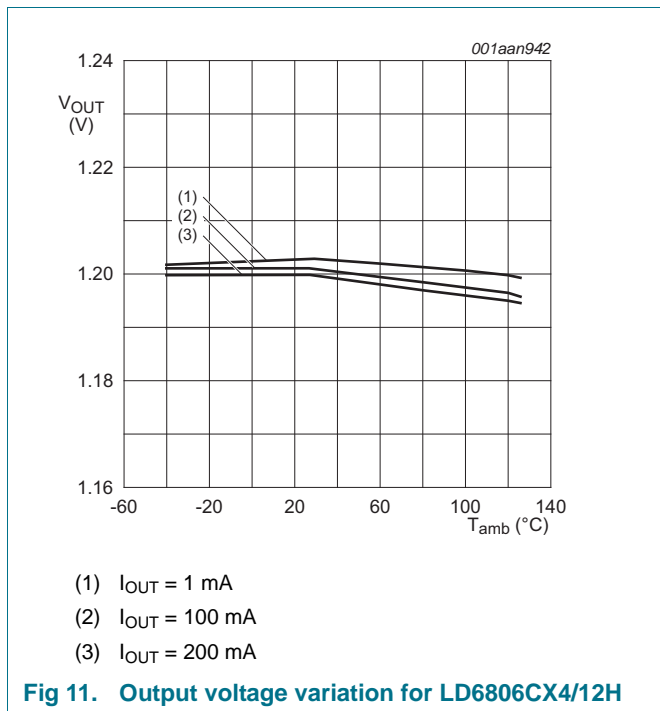

9.3 Quiescent current

Quiescent or ground current is the difference between the input and the output current of the regulator.

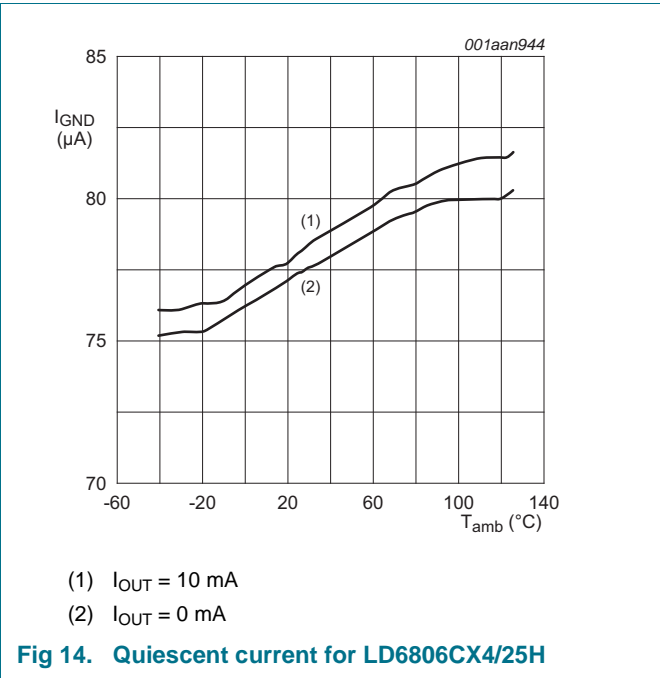
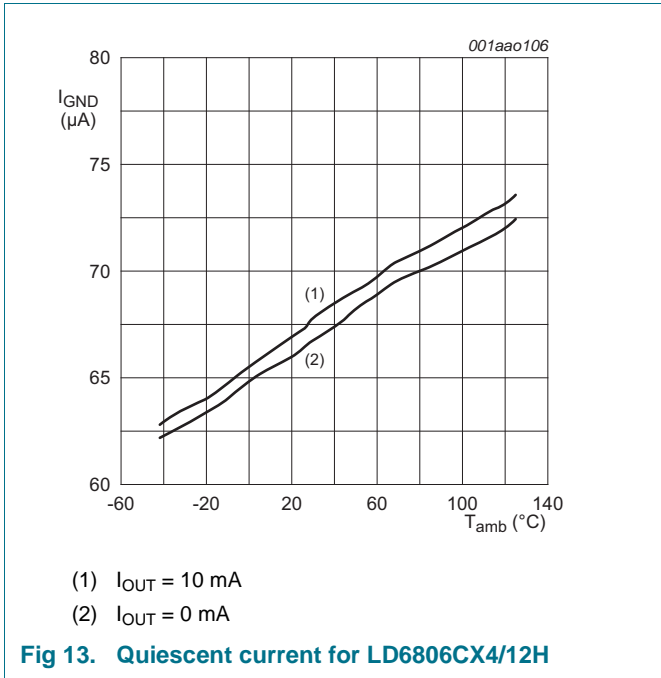

9.4 Noise

Output noise voltage of an LDO circuit is given as noise density or RMS output noise voltage over a defined range of frequencies (10 Hz to 100 kHz). Permanent conditions are a constant output current and a ripple-free input voltage. The output noise voltage is generated by the LDO regulator.

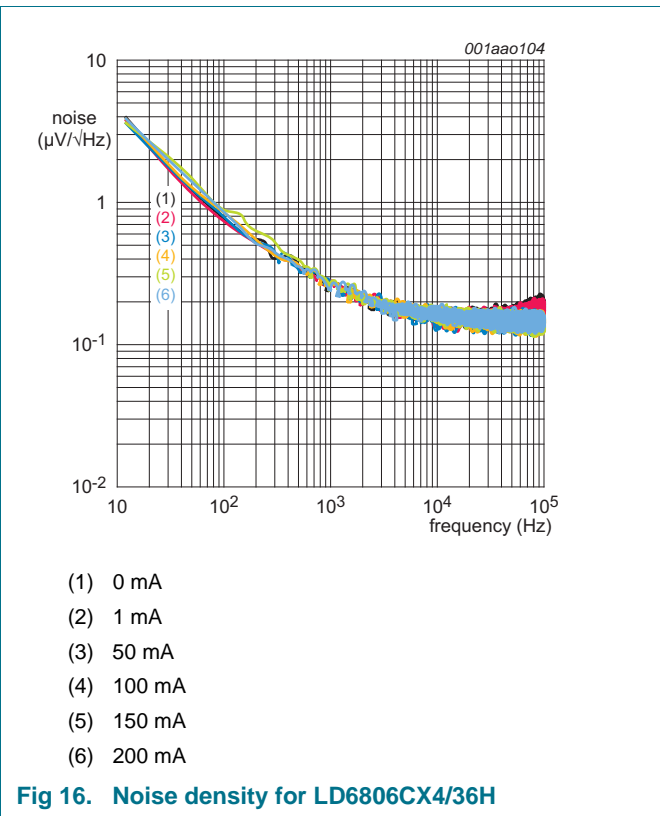
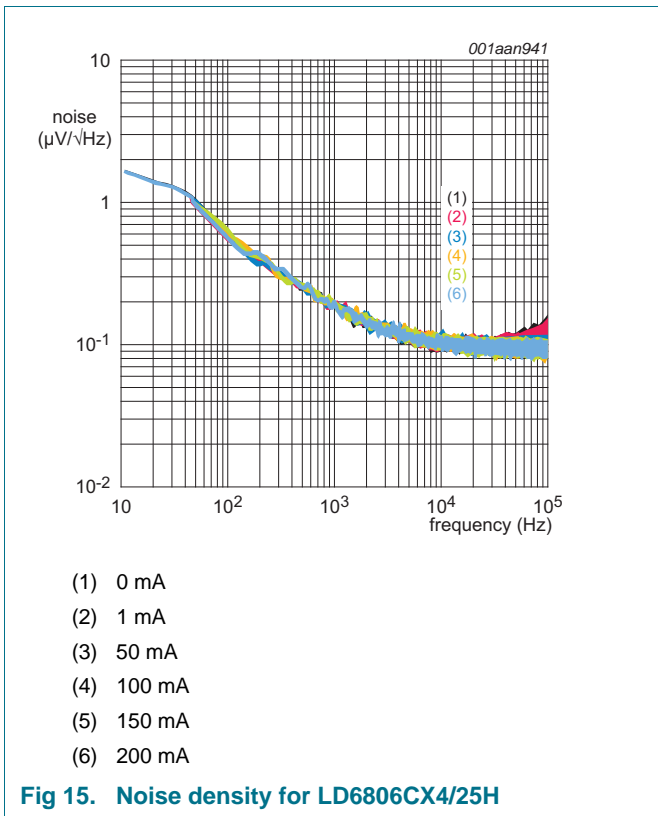

9.5 Line regulation

Line regulation response is the capability of the circuit to maintain the nominal output voltage while varying the input voltage.

$$Regulation[\%/V] = \frac{\Delta V_{OUT}}{\Delta V_{IN}} \times \frac{100}{V_{OUT}}$$

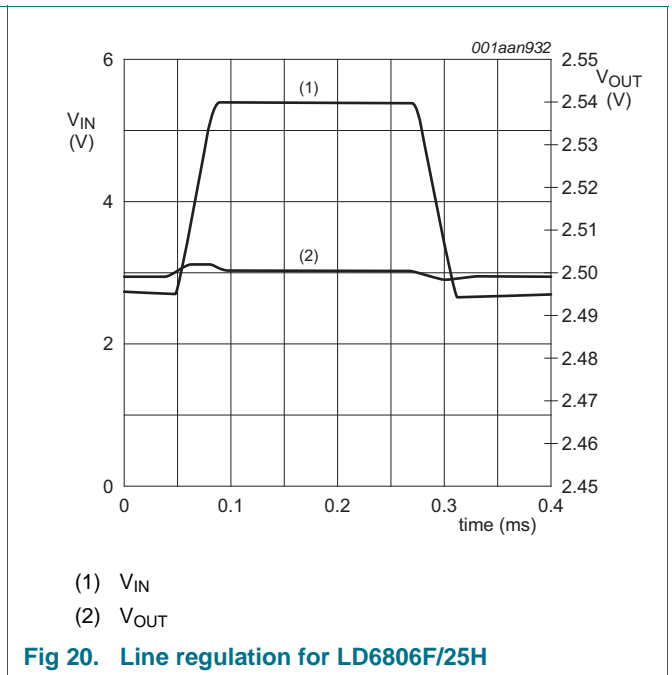
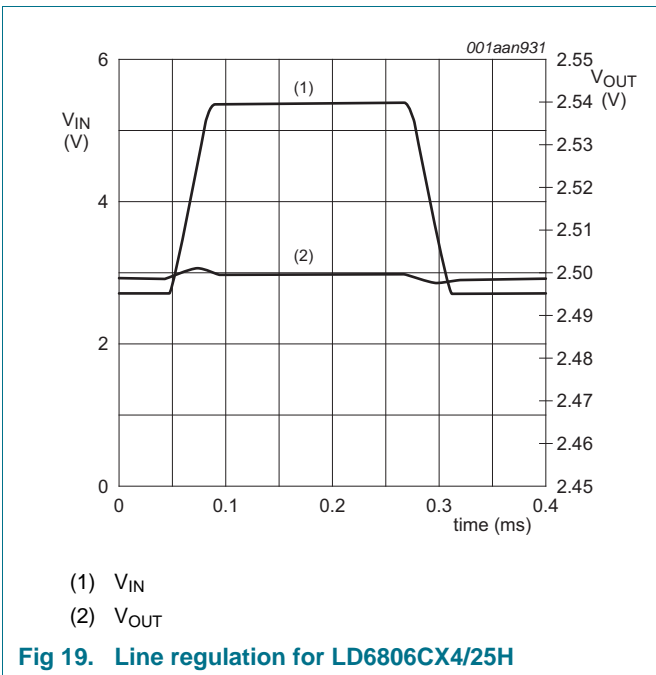
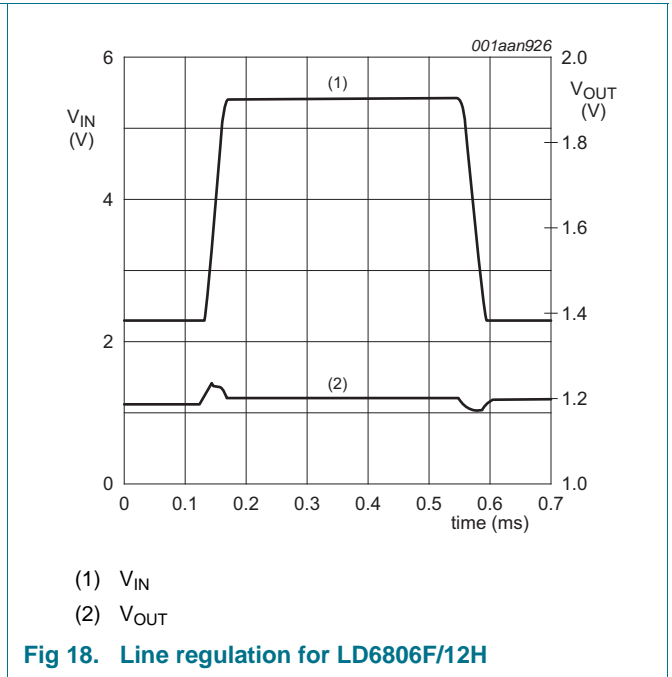
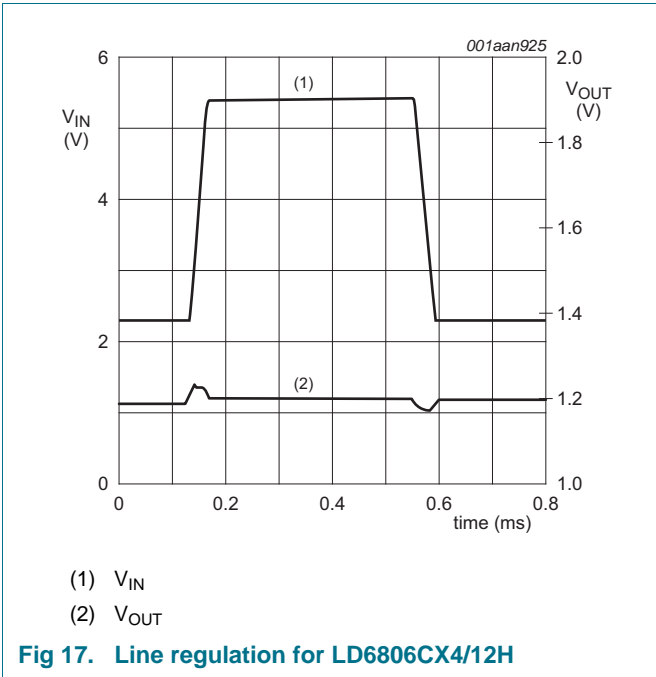

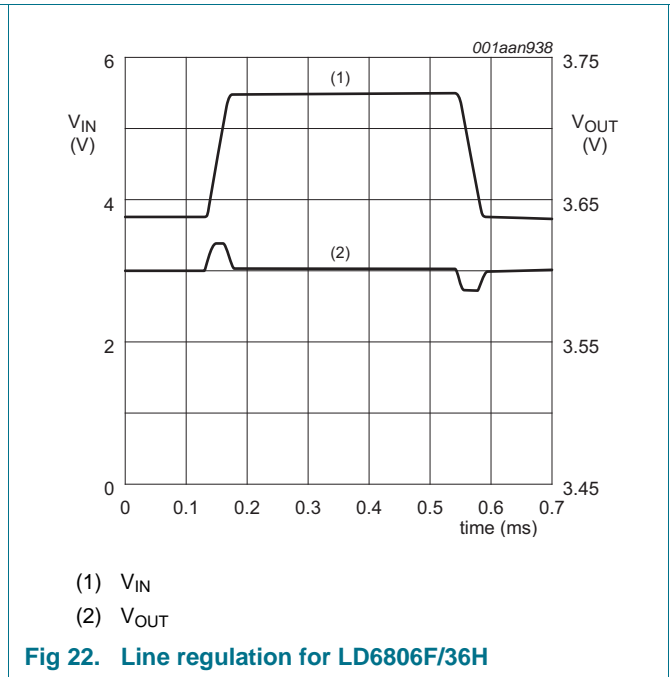
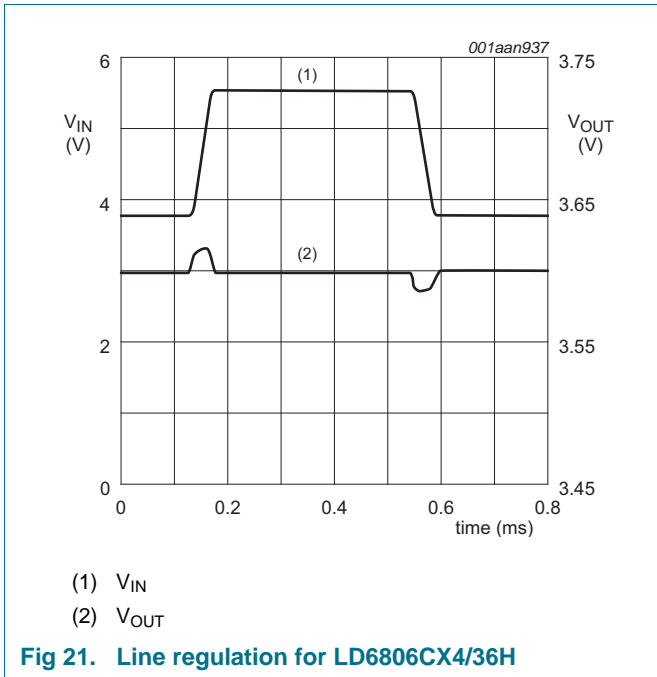

9.6 Load regulation

Load regulation is the capability of the circuit to maintain the nominal output voltage while varying the output load current.

$$\text{Load regulation}[\%/mA] = \frac{\frac{\Delta V_{OUT}}{V_{O(nom)}} \times 100}{I_{OUT(max)}}$$

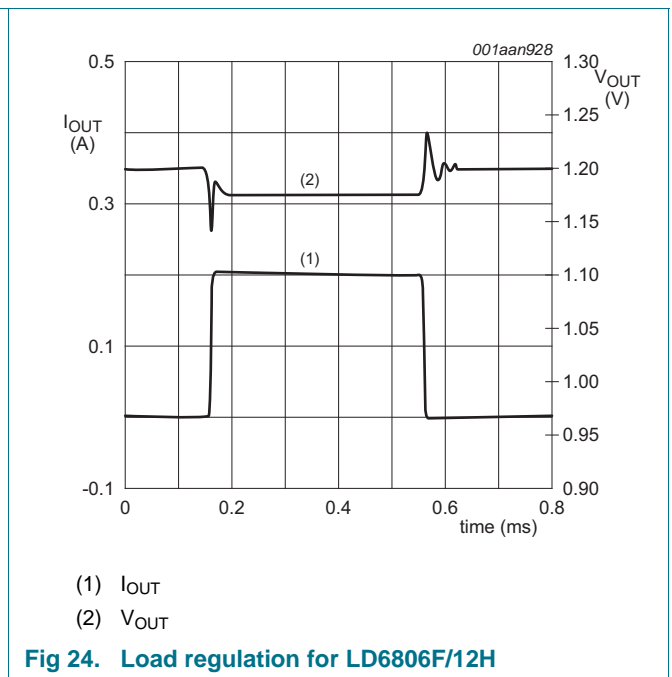
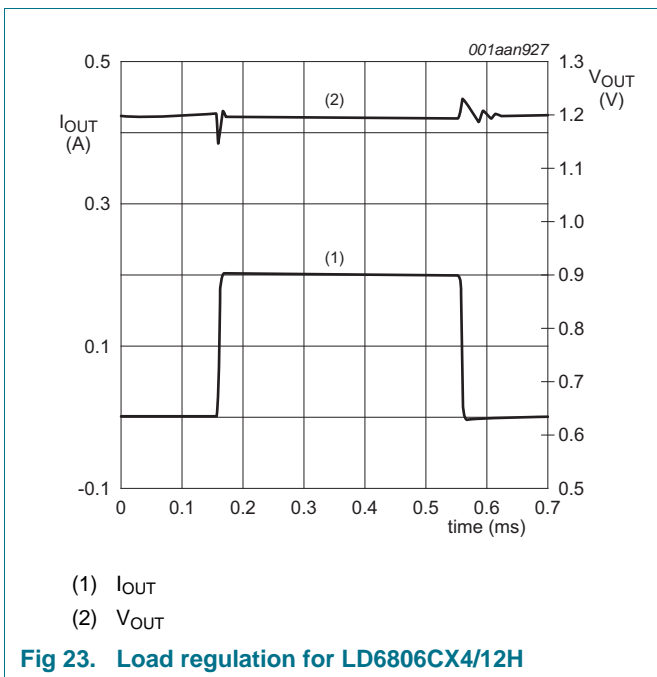

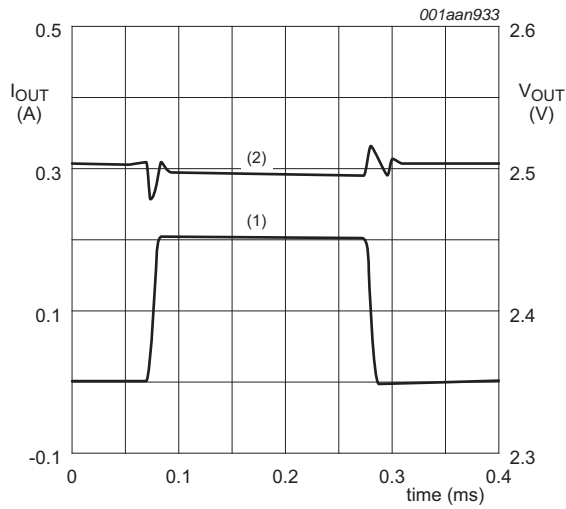

- (1) I_{OUT}
- (2) V_{OUT}

Fig 25. Load regulation for LD6806CX4/25H

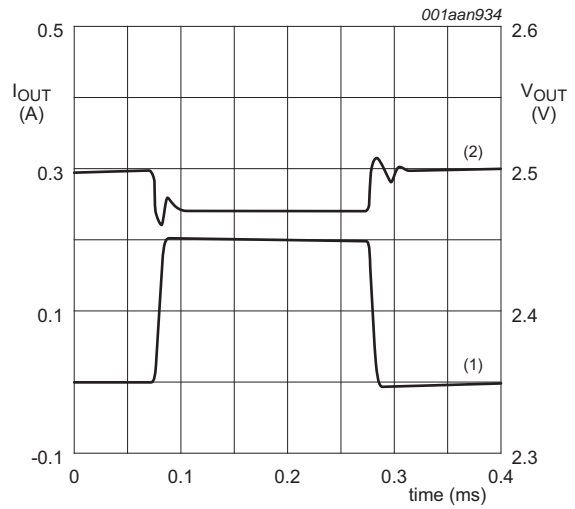

- (1) I_{OUT}
- (2) V_{OUT}

Fig 26. Load regulation for LD6806F/25H

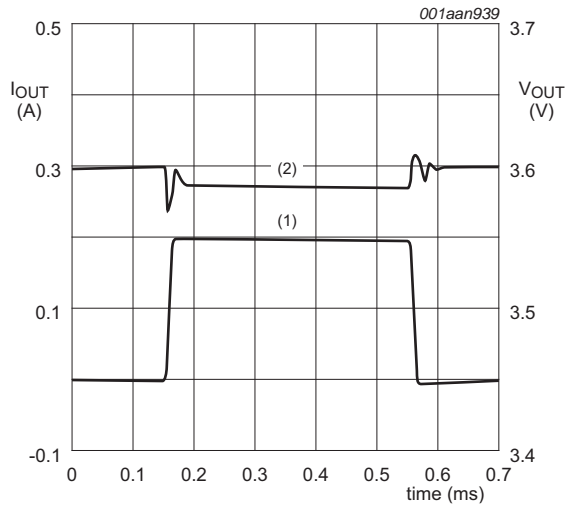

- (1) I_{OUT}
- (2) V_{OUT}

Fig 27. Load regulation for LD6806CX4/36H

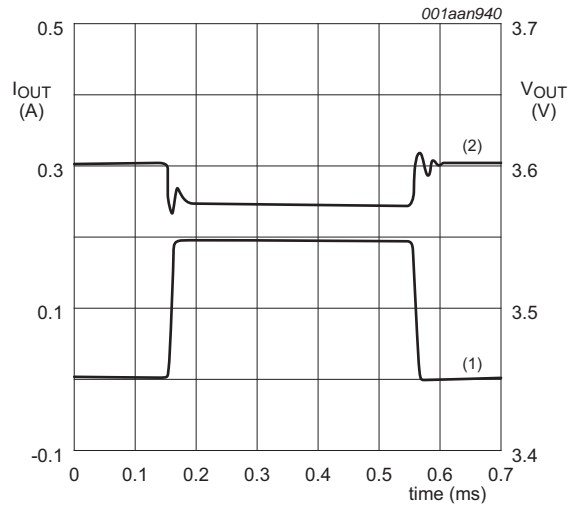

- (1) I_{OUT}
- (2) V_{OUT}

Fig 28. Load regulation for LD6806F/36H

9.7 Start-up and shut down

Start-up time defines the time needed for the LDO to achieve 95 % of its typical output voltage level after activation via the enable pin.

Shut down time defines the time needed for the LDO to pull-down the output voltage to 10% of its nominal output voltage after deactivation via the enable pin.

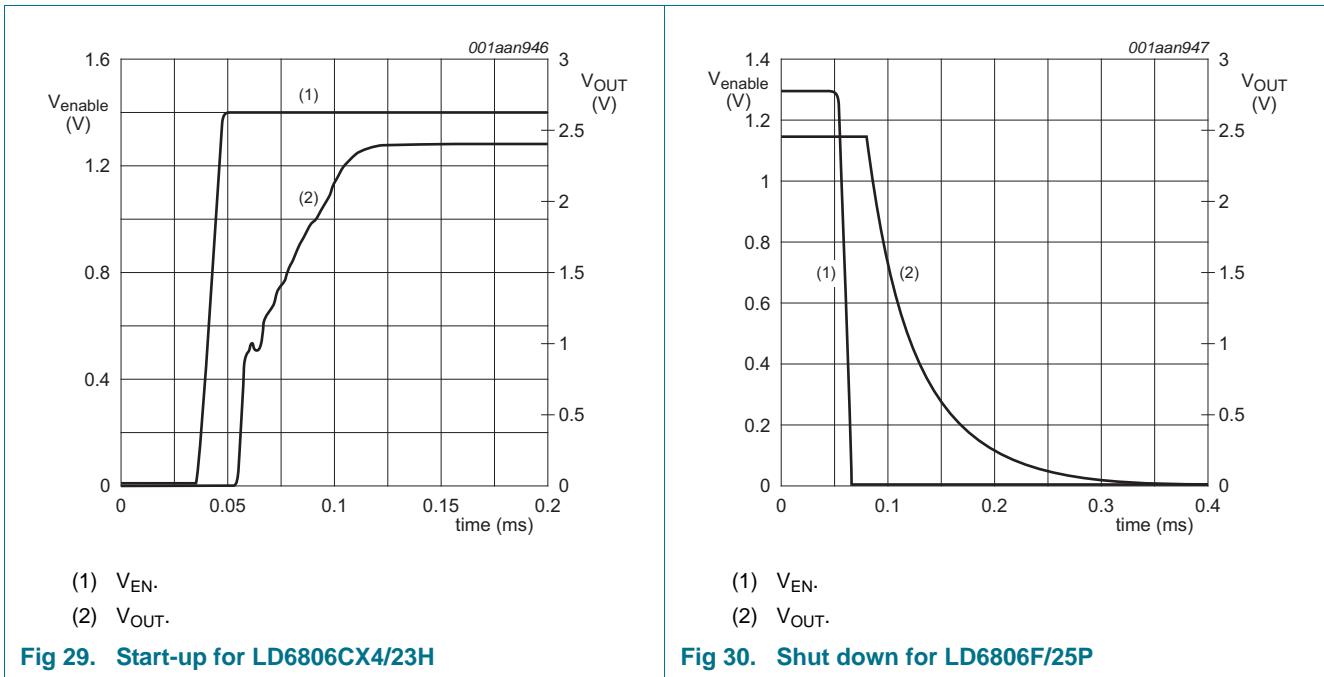

9.8 Power Supply Rejection Ratio (PSRR)

PSRR stands for the capability of the regulator to suppress unwanted signals on the input voltage like noise or ripples.

$$PSRR[dB] = 20 \log \frac{V_{out(ripple)}}{V_{in(ripple)}} \text{ for all frequencies}$$

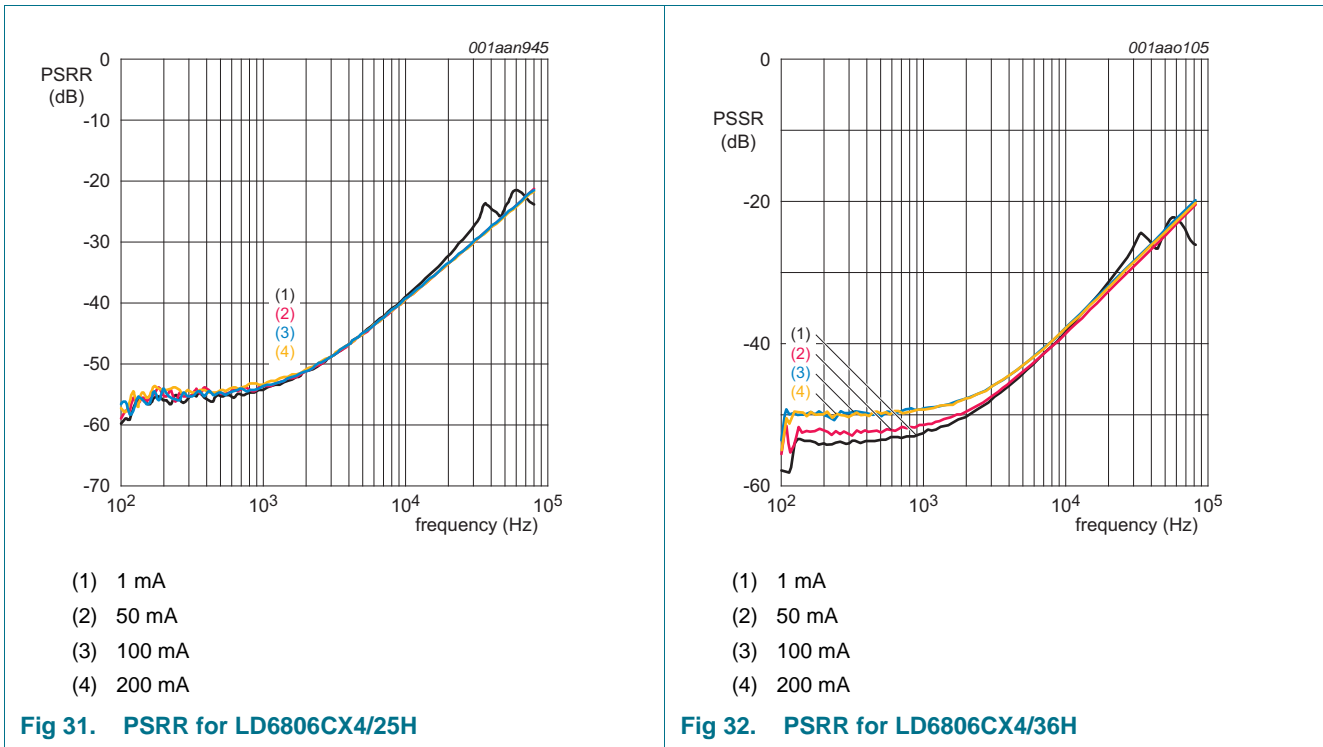

9.9 Enable threshold voltage

An active HIGH signal enables the LDO when the signal exceeds the minimum input HIGH voltage threshold. The device is in Off state as long the signal is below the maximum LOW threshold. The input voltage threshold is independent from the LDO supply voltage.

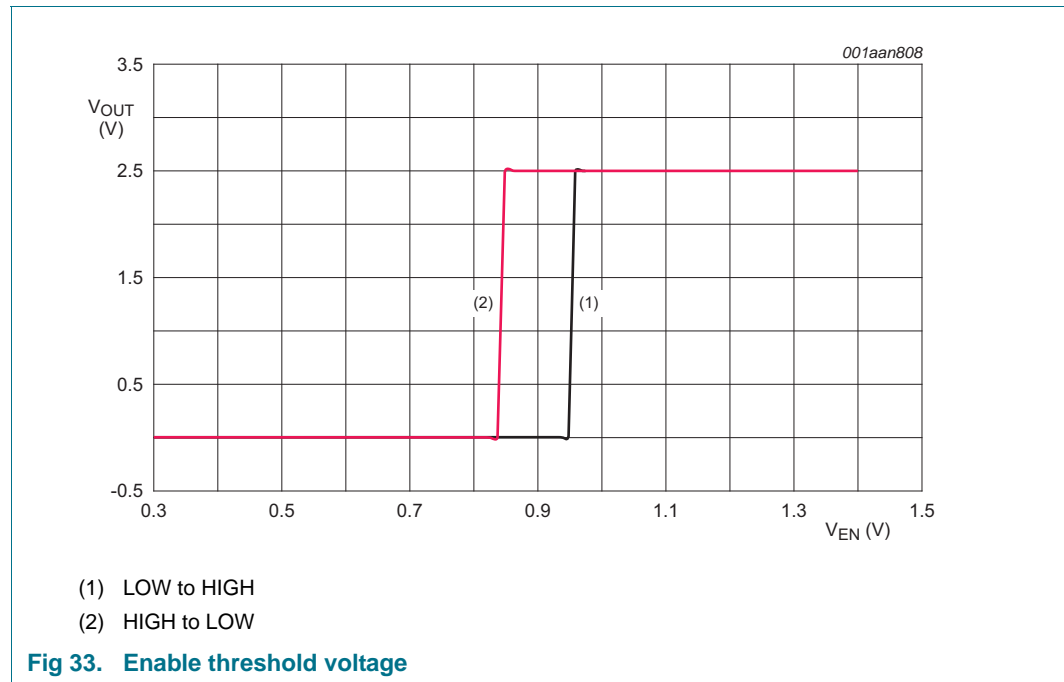

10. Application information

10.1 Output capacitor values

The LD6806 series requires external capacitors at the output to guarantee a stable regulator behavior. Also an input capacitor is recommended to keep the input voltage stable. These capacitors should not under-run the specified minimum Equivalent Series Resistance (ESR).

The absolute value of the total capacitance attached to the output pin OUT influences the shutdown time ($t_{sd(reg)}$) of the LD6806 series.

Table 11. External load capacitor

Symbol	Parameter	Conditions	Min	Typ	Max	Unit
$C_{L(ext)}$	external load capacitance		[1] -	1.0	-	μF
ESR	equivalent series resistance		5	-	500	$\text{m}\Omega$

[1] The minimum value of capacitance for stability and correct operation is 0.7 μF . The capacitor tolerance should be $\pm 30\%$ or better over the temperature range. The full range of operating conditions for the capacitor in the application should be considered during device selection to ensure that this minimum capacitance specification is met. The recommended capacitor type is X7R to meet the full device temperature specification of $-40\text{ }^\circ\text{C}$ to $+125\text{ }^\circ\text{C}$.

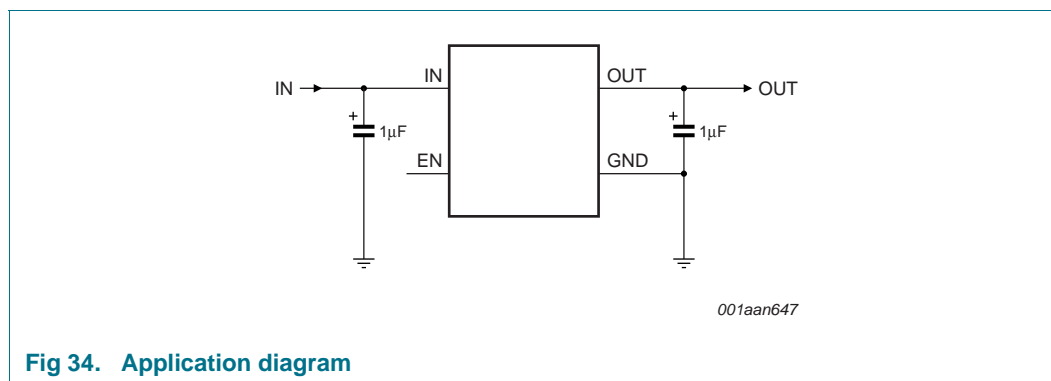

Fig 34. Application diagram

11. Test information

11.1 Quality information

This product has been qualified in accordance with *NX2-00001 NXP Semiconductors Quality and Reliability Specification* and is suitable for use in consumer applications.

12. Package outline

WLCSP4: wafer level chip-size package; 4 bumps (2 x 2)

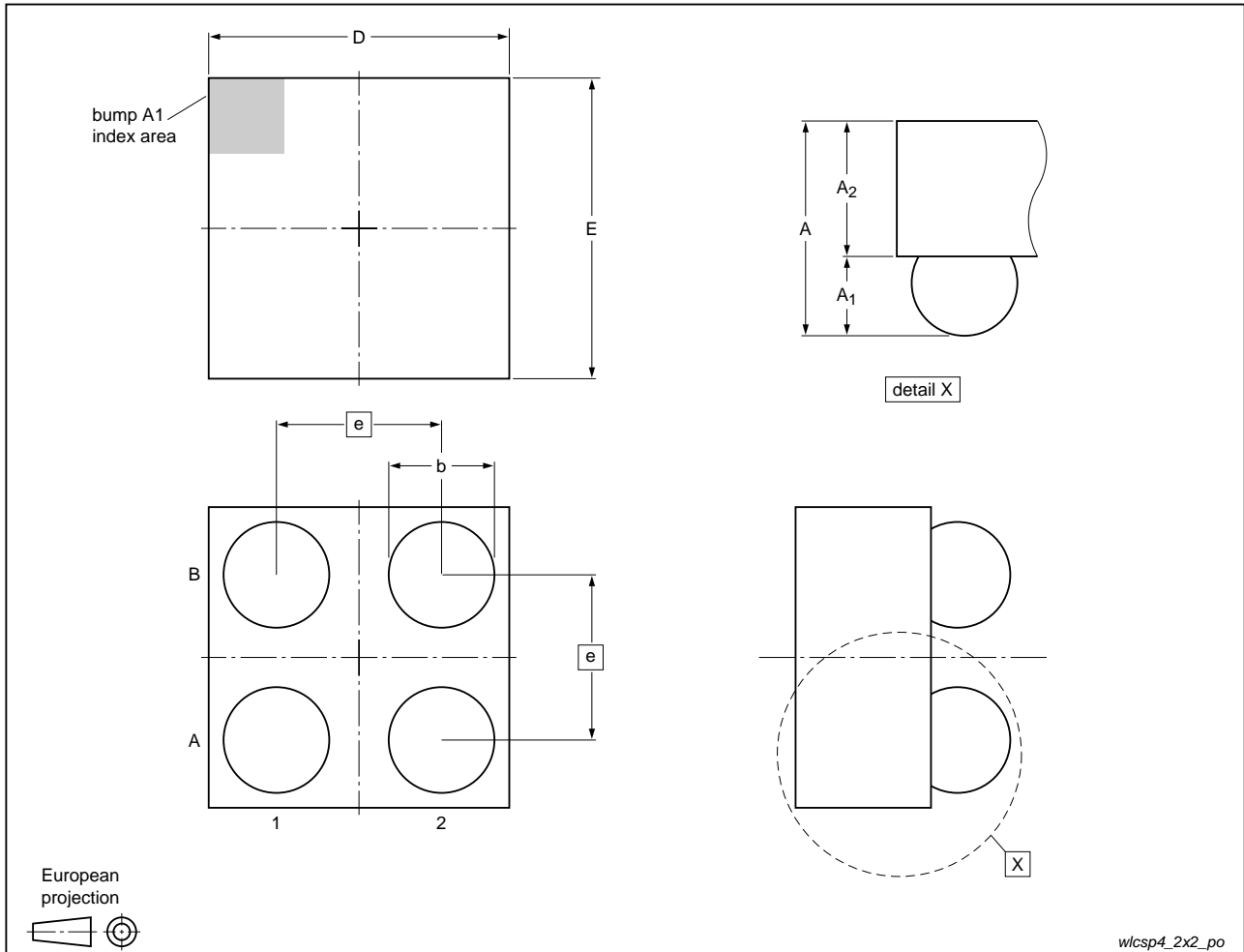

Fig 35. Package outline WLCSP4

Table 12. Dimensions of LD6806CX4/xxx for package outline WLCSP4; see [Figure 35](#)

Symbol	Min	Typ	Max	Unit
A	0.44	0.47	0.50	mm
A ₁	0.18	0.20	0.22	mm
A ₂	0.26	0.27	0.28	mm
b	0.21	0.26	0.31	mm
D	0.71	0.76	0.81	mm
E	0.71	0.76	0.81	mm
e	-	0.4	-	mm

WLCSP4: wafer level chip-size package with backside coating; 4 bumps (2 x 2)

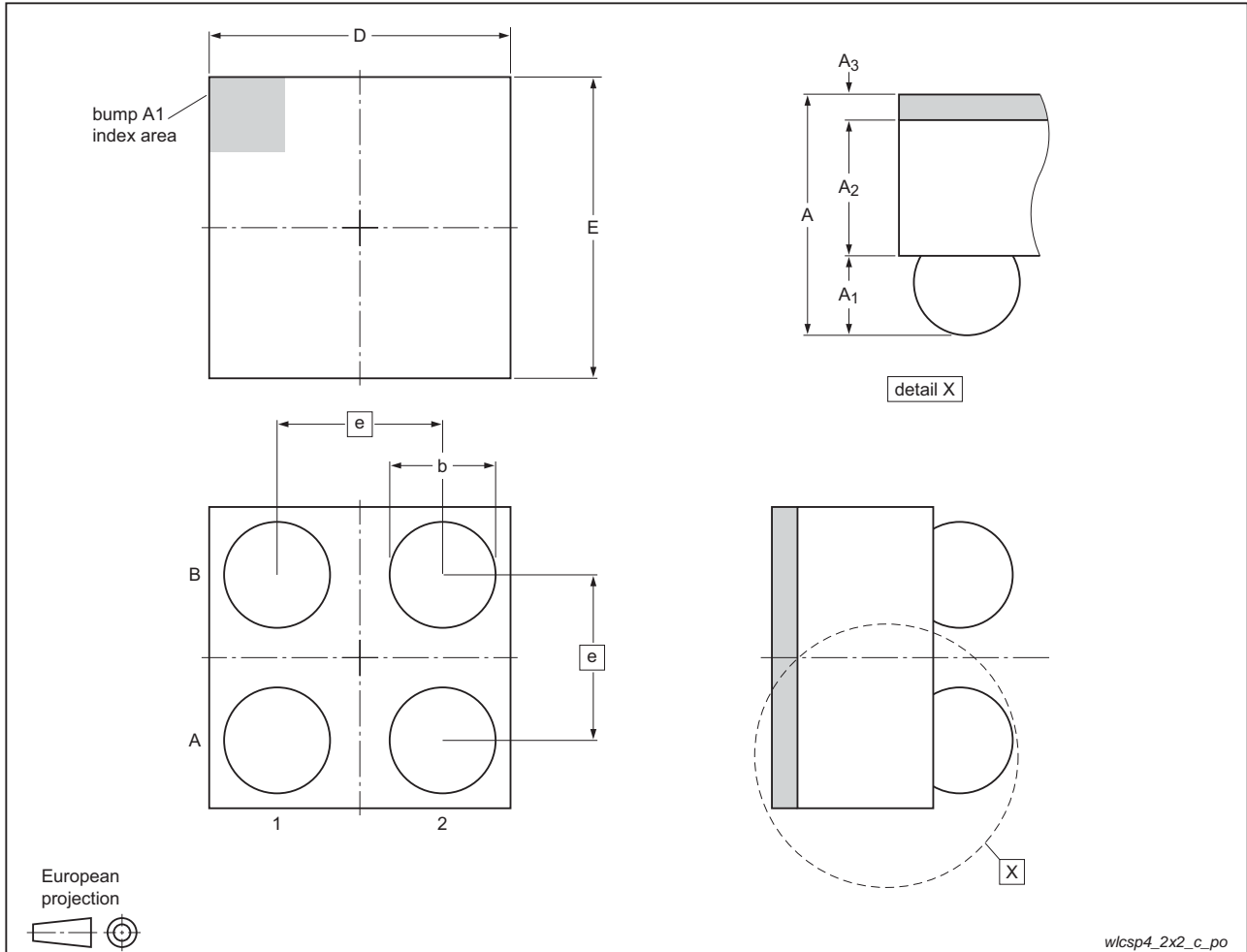

Fig 36. Package outline WLCSP4 with backside coating

Table 13. Dimensions of LD6806CX4/Cxxx for package outline WLCSP4 with backside coating; see Figure 36

Symbol	Min	Typ	Max	Unit
A	0.47	0.51	0.55	mm
A ₁	0.18	0.20	0.22	mm
A ₂	0.26	0.27	0.28	mm
A ₃	0.03	0.04	0.05	mm
b	0.21	0.26	0.31	mm
D	0.71	0.76	0.81	mm
E	0.71	0.76	0.81	mm
e	-	0.4	-	mm

XSON6: plastic extremely thin small outline package; no leads; 6 terminals; body 1 x 1.45 x 0.5 mm

SOT886

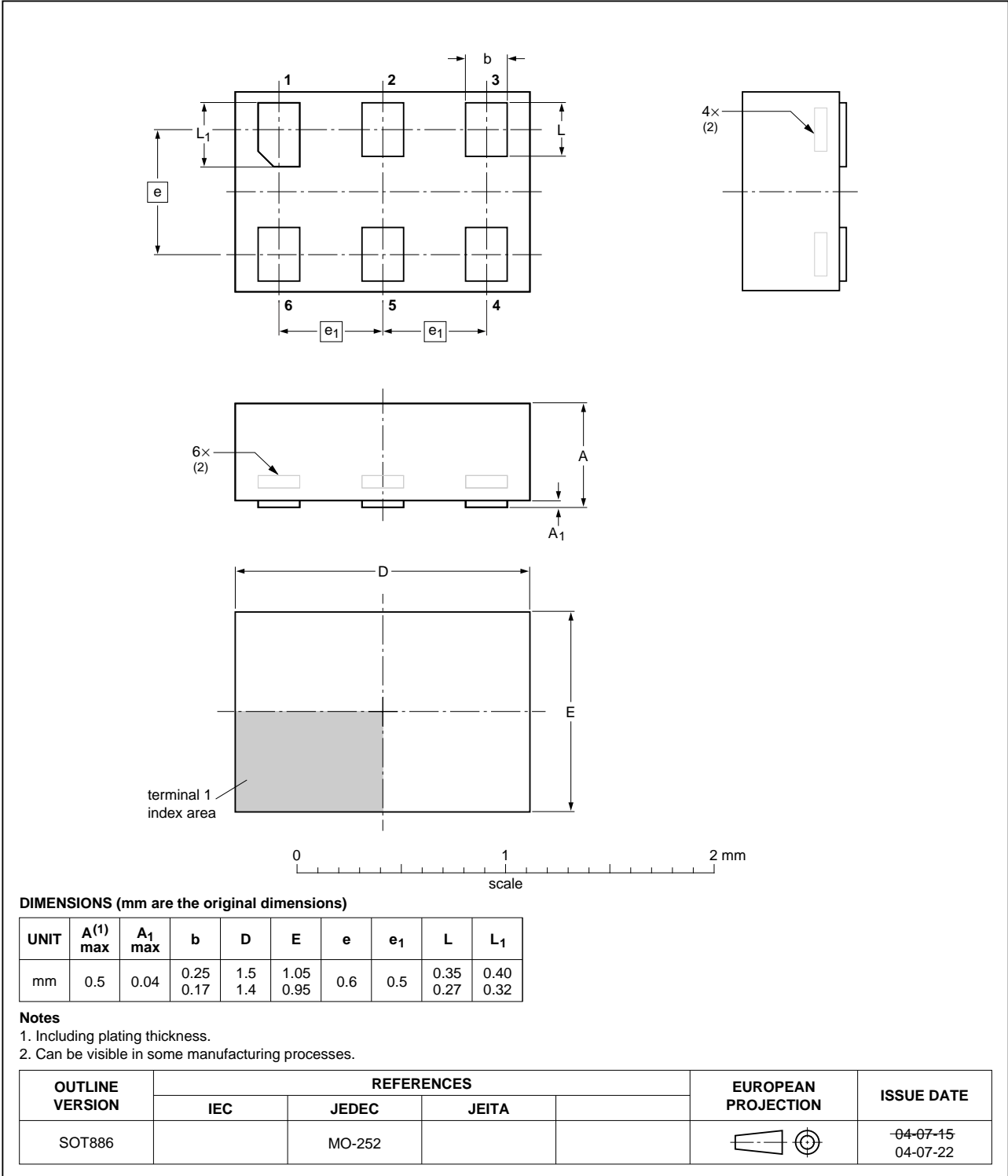

Fig 37. Package outline SOT886 (XSON6)

Plastic surface-mounted package; 5 leads

SOT753

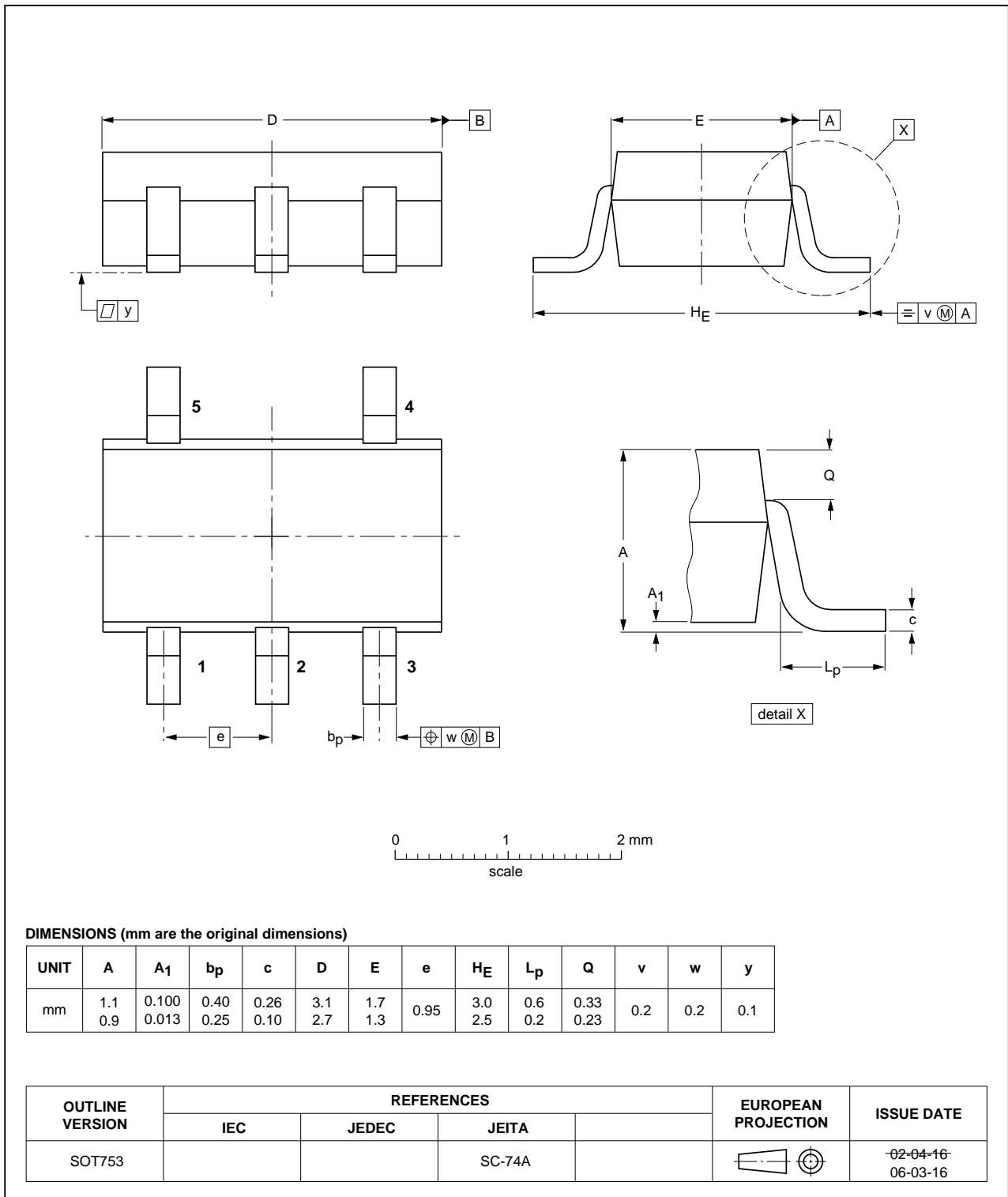

Fig 38. SOT753; Plastic surface-mounted package; 5 leads

13. Soldering

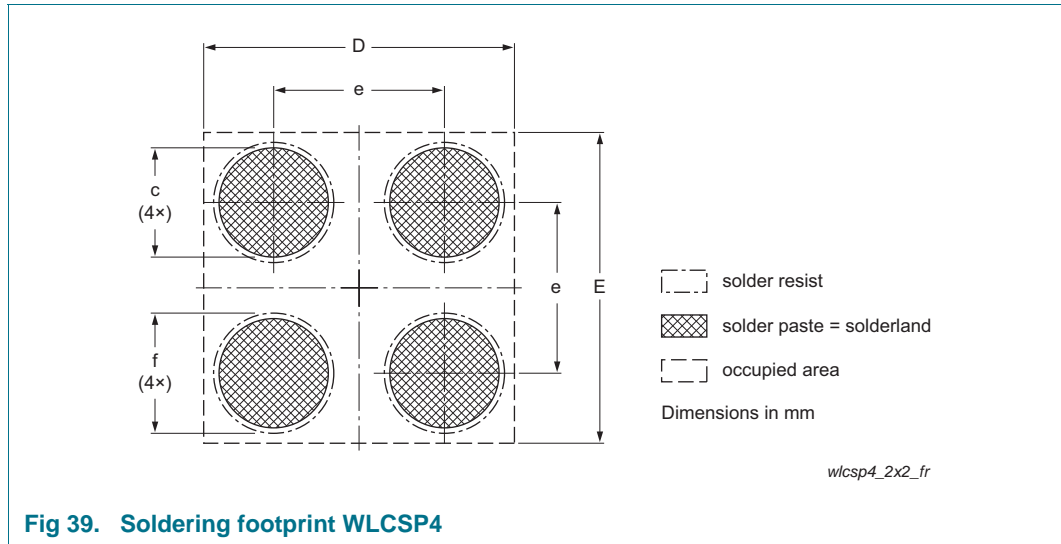

Fig 39. Soldering footprint WLCSP4

Table 14. Dimensions of soldering footprint WLCSP4; see Figure 39

Symbol	Min	Typ	Max	Unit
c	-	0.25	-	mm
D	0.71	0.76	0.81	mm
E	0.71	0.76	0.81	mm
e	-	0.4	-	mm
f	-	0.325	-	mm

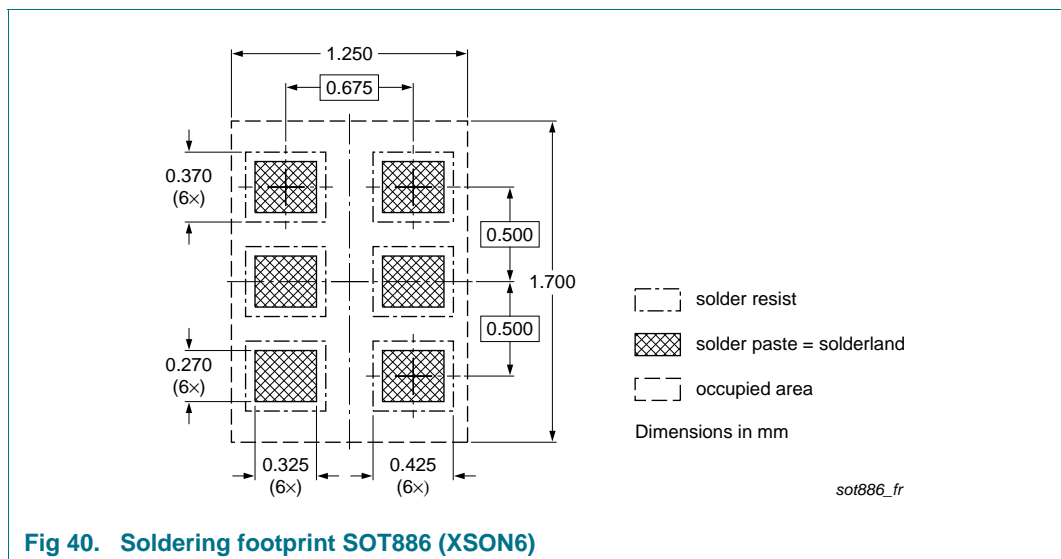
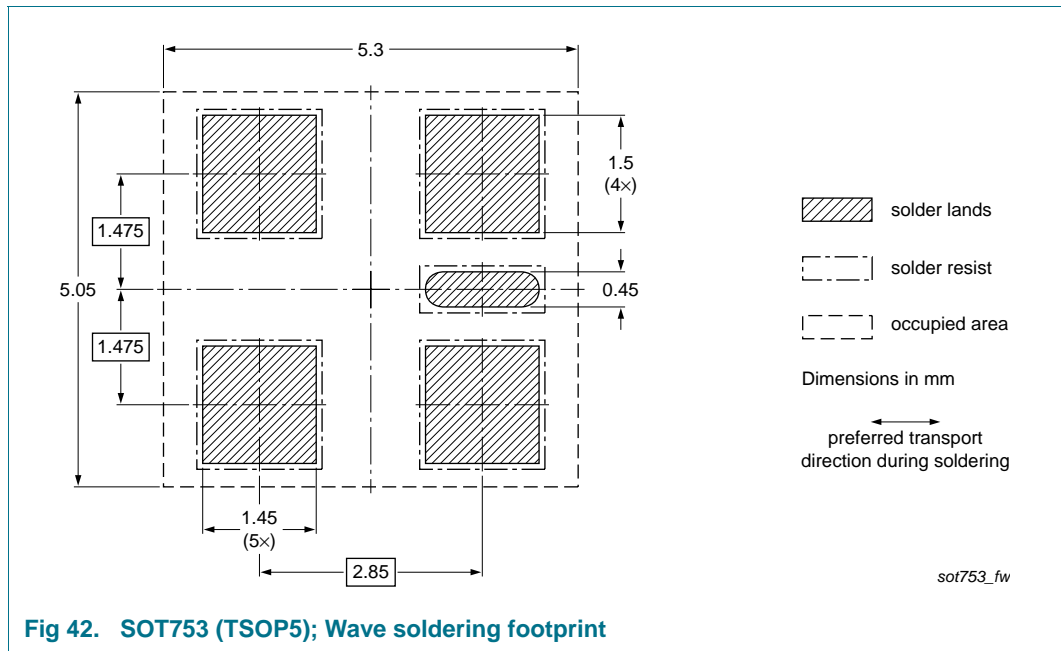
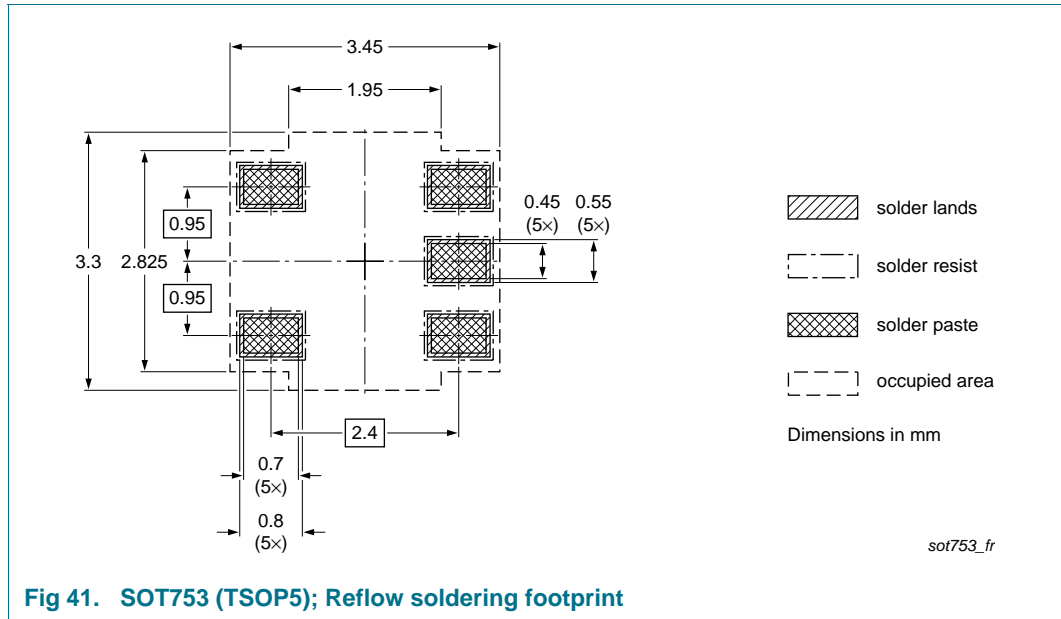

Fig 40. Soldering footprint SOT886 (XSON6)



14. Soldering of WLCSP packages

14.1 Introduction to soldering WLCSP packages

This text provides a very brief insight into a complex technology. A more in-depth account of soldering WLCSP (Wafer Level Chip-Size Packages) can be found in application note AN10439 "Wafer Level Chip Scale Package" and in application note AN10365 "Surface mount reflow soldering description".

Wave soldering is not suitable for this package.

All NXP WLCSP packages are lead-free.

14.2 Board mounting

Board mounting of a WLCSP requires several steps:

1. Solder paste printing on the PCB
2. Component placement with a pick and place machine
3. The reflow soldering itself

14.3 Reflow soldering

Key characteristics in reflow soldering are:

- Lead-free versus SnPb soldering; note that a lead-free reflow process usually leads to higher minimum peak temperatures (see [Figure 43](#)) than a PbSn process, thus reducing the process window
- Solder paste printing issues, such as smearing, release, and adjusting the process window for a mix of large and small components on one board
- Reflow temperature profile; this profile includes preheat, reflow (in which the board is heated to the peak temperature), and cooling down. It is imperative that the peak temperature is high enough for the solder to make reliable solder joints (a solder paste characteristic) while being low enough that the packages and/or boards are not damaged. The peak temperature of the package depends on package thickness and volume and is classified in accordance with [Table 15](#).

Table 15. Lead-free process (from J-STD-020C)

Package thickness (mm)	Package reflow temperature (°C)		
	Volume (mm ³)		
	< 350	350 to 2000	> 2000
< 1.6	260	260	260
1.6 to 2.5	260	250	245
> 2.5	250	245	245

Moisture sensitivity precautions, as indicated on the packing, must be respected at all times.

Studies have shown that small packages reach higher temperatures during reflow soldering, see [Figure 43](#).

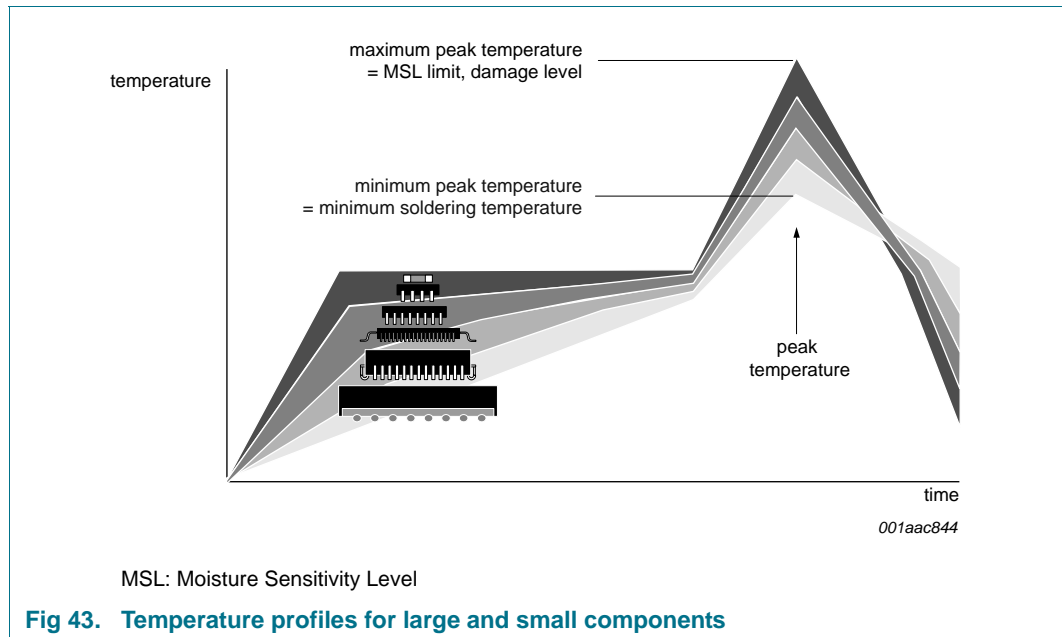

For further information on temperature profiles, refer to application note *AN10365 "Surface mount reflow soldering description"*.

14.3.1 Stand off

The stand off between the substrate and the chip is determined by:

- The amount of printed solder on the substrate
- The size of the solder land on the substrate
- The bump height on the chip

The higher the stand off, the better the stresses are released due to TEC (Thermal Expansion Coefficient) differences between substrate and chip.

14.3.2 Quality of solder joint

A flip-chip joint is considered to be a good joint when the entire solder land has been wetted by the solder from the bump. The surface of the joint should be smooth and the shape symmetrical. The soldered joints on a chip should be uniform. Voids in the bumps after reflow can occur during the reflow process in bumps with high ratio of bump diameter to bump height, i.e. low bumps with large diameter. No failures have been found to be related to these voids. Solder joint inspection after reflow can be done with X-ray to monitor defects such as bridging, open circuits and voids.

14.3.3 Rework

In general, rework is not recommended. By rework we mean the process of removing the chip from the substrate and replacing it with a new chip. If a chip is removed from the substrate, most solder balls of the chip will be damaged. In that case it is recommended not to re-use the chip again.

Device removal can be done when the substrate is heated until it is certain that all solder joints are molten. The chip can then be carefully removed from the substrate without damaging the tracks and solder lands on the substrate. Removing the device must be done using plastic tweezers, because metal tweezers can damage the silicon. The surface of the substrate should be carefully cleaned and all solder and flux residues and/or underfill removed. When a new chip is placed on the substrate, use the flux process instead of solder on the solder lands. Apply flux on the bumps at the chip side as well as on the solder pads on the substrate. Place and align the new chip while viewing with a microscope. To reflow the solder, use the solder profile shown in application note AN10365 “Surface mount reflow soldering description”.

14.3.4 Cleaning

Cleaning can be done after reflow soldering.

15. Soldering of SMD packages

This text provides a very brief insight into a complex technology. A more in-depth account of soldering ICs can be found in Application Note AN10365 “Surface mount reflow soldering description”.

15.1 Introduction to soldering

Soldering is one of the most common methods through which packages are attached to Printed Circuit Boards (PCBs), to form electrical circuits. The soldered joint provides both the mechanical and the electrical connection. There is no single soldering method that is ideal for all IC packages. Wave soldering is often preferred when through-hole and Surface Mount Devices (SMDs) are mixed on one printed wiring board; however, it is not suitable for fine pitch SMDs. Reflow soldering is ideal for the small pitches and high densities that come with increased miniaturization.

15.2 Wave and reflow soldering

Wave soldering is a joining technology in which the joints are made by solder coming from a standing wave of liquid solder. The wave soldering process is suitable for the following:

- Through-hole components
- Leaded or leadless SMDs, which are glued to the surface of the printed circuit board

Not all SMDs can be wave soldered. Packages with solder balls, and some leadless packages which have solder lands underneath the body, cannot be wave soldered. Also, leaded SMDs with leads having a pitch smaller than ~0.6 mm cannot be wave soldered, due to an increased probability of bridging.

The reflow soldering process involves applying solder paste to a board, followed by component placement and exposure to a temperature profile. Leaded packages, packages with solder balls, and leadless packages are all reflow solderable.

Key characteristics in both wave and reflow soldering are:

- Board specifications, including the board finish, solder masks and vias
- Package footprints, including solder thieves and orientation

- The moisture sensitivity level of the packages
- Package placement
- Inspection and repair
- Lead-free soldering versus SnPb soldering

15.3 Wave soldering

Key characteristics in wave soldering are:

- Process issues, such as application of adhesive and flux, clinching of leads, board transport, the solder wave parameters, and the time during which components are exposed to the wave
- Solder bath specifications, including temperature and impurities

15.4 Reflow soldering

Key characteristics in reflow soldering are:

- Lead-free versus SnPb soldering; note that a lead-free reflow process usually leads to higher minimum peak temperatures (see [Figure 44](#)) than a SnPb process, thus reducing the process window
- Solder paste printing issues including smearing, release, and adjusting the process window for a mix of large and small components on one board
- Reflow temperature profile; this profile includes preheat, reflow (in which the board is heated to the peak temperature) and cooling down. It is imperative that the peak temperature is high enough for the solder to make reliable solder joints (a solder paste characteristic). In addition, the peak temperature must be low enough that the packages and/or boards are not damaged. The peak temperature of the package depends on package thickness and volume and is classified in accordance with [Table 16](#) and [17](#)

Table 16. SnPb eutectic process (from J-STD-020C)

Package thickness (mm)	Package reflow temperature (°C)	
	Volume (mm ³)	
	< 350	≥ 350
< 2.5	235	220
≥ 2.5	220	220

Table 17. Lead-free process (from J-STD-020C)

Package thickness (mm)	Package reflow temperature (°C)		
	Volume (mm ³)		
	< 350	350 to 2000	> 2000
< 1.6	260	260	260
1.6 to 2.5	260	250	245
> 2.5	250	245	245

Moisture sensitivity precautions, as indicated on the packing, must be respected at all times.

Studies have shown that small packages reach higher temperatures during reflow soldering, see [Figure 44](#).

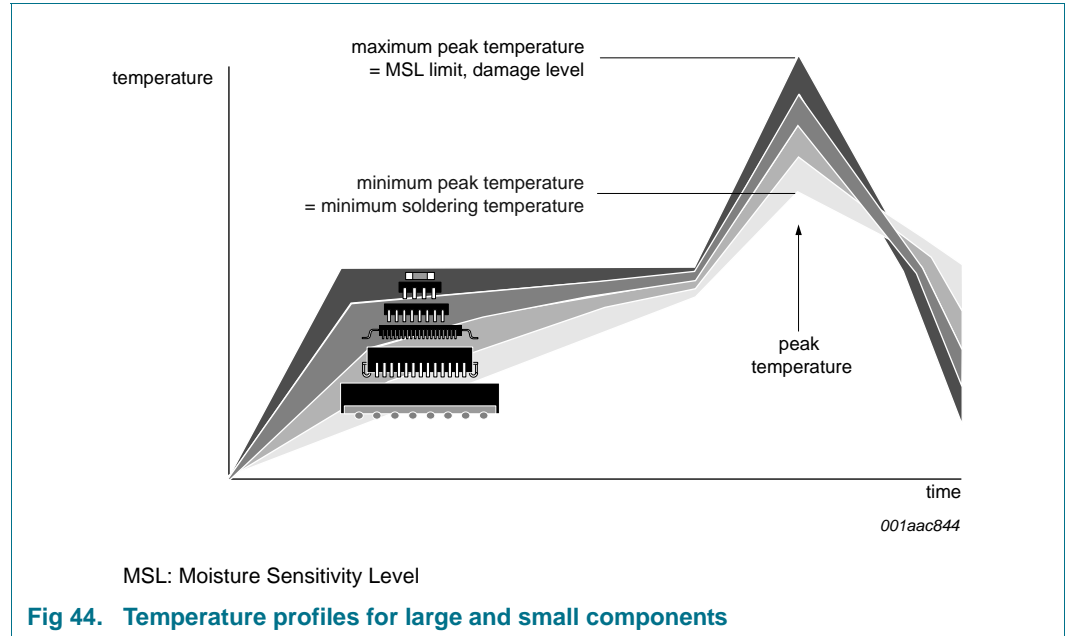

For further information on temperature profiles, refer to Application Note *AN10365 "Surface mount reflow soldering description"*.

16. Mounting

16.1 PCB design guidelines

It is recommended, for optimum performance, to use a Non-Solder Mask Defined (NSMD), also known as a copper-defined design, incorporating laser-drilled micro-vias connecting the ground pads to a buried ground-plane layer. This results in the lowest possible ground inductance and provides the best high frequency and ESD performance. Refer to [Table 18](#) for the recommended PCB design parameters.

Table 18. Recommended PCB design parameters

Parameter	Value or specification
PCB pad diameter	250 μm
Micro-via diameter	100 μm (0.004 inch)
Solder mask aperture diameter	325 μm
Copper thickness	20 μm to 40 μm
Copper finish	AuNi or OSP
PCB material	FR4

16.2 PCB assembly guidelines for Pb-free soldering

Table 19. Assembly recommendations

Parameter	Value or specification
Solder screen aperture diameter	250 μm
Solder screen thickness	100 μm (0.004 inch)
Solder paste: Pb-free	SnAg (3 % to 4 %); Cu (0.5 % to 0.9 %)
Solder to flux ratio	50 : 50
Solder reflow profile	see Figure 45

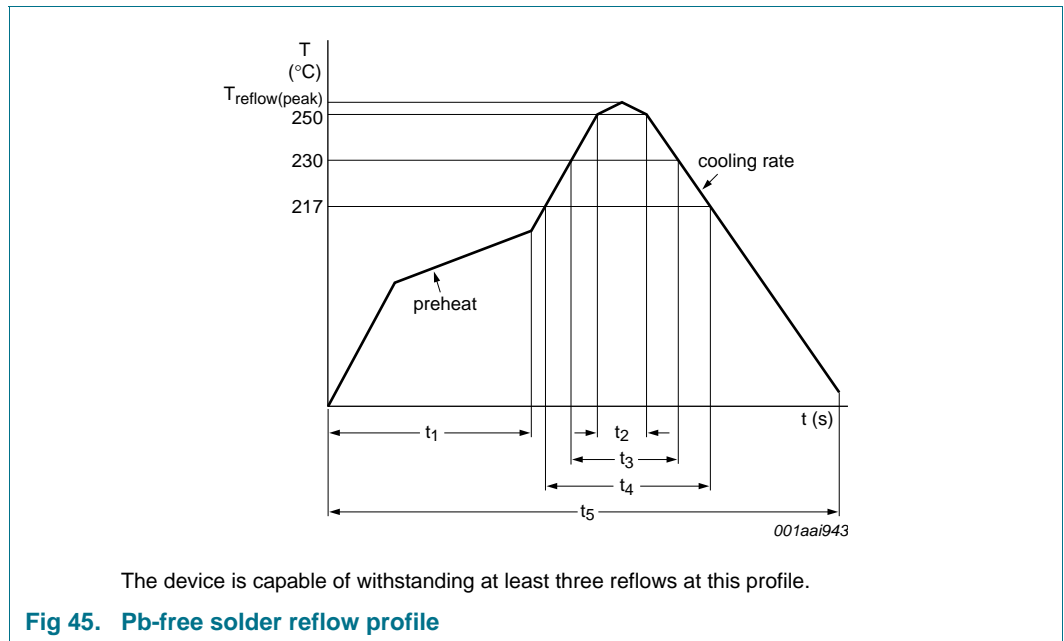

Fig 45. Pb-free solder reflow profile

Table 20. Characteristics

Symbol	Parameter	Conditions	Min	Typ	Max	Unit
$T_{\text{reflow(peak)}}$	peak reflow temperature		230	-	260	$^{\circ}\text{C}$
t_1	time 1	soak time	60	-	180	s
t_2	time 2	time during $T \geq 250^{\circ}\text{C}$	-	-	30	s
t_3	time 3	time during $T \geq 230^{\circ}\text{C}$	10	-	50	s
t_4	time 4	time during $T > 217^{\circ}\text{C}$	30	-	150	s
t_5	time 5		-	-	540	s
dT/dt	rate of change of temperature	cooling rate	-	-	-6	$^{\circ}\text{C/s}$
		preheat	2.5	-	4.0	$^{\circ}\text{C/s}$

17. Abbreviations

Table 21. Abbreviations

Acronym	Description
CSP	Chip-Size Package
DUT	Device Under Test
EMI	ElectroMagnetic Interference
ESD	ElectroStatic Discharge
FR4	Flame Retard 4
HBM	Human Body Model
LDO	Low DropOut
MM	Machine Model
NSMD	Non-Solder Mask Design
OSP	Organic Solderability Preservation
PCB	Printed-Circuit Board
PSRR	Power Supply Rejection Ratio
PSU	Power Supply Unit
QRS	Quality and Reliability Specification
RMS	Root Mean Square
WLCSP	Wafer Level Chip-Size Package

18. References

- [1] **IEC 60134** — Rating systems for electronic tubes and valves and analogous semiconductor devices
- [2] **IEC 61340-3-1** — Methods for simulation of electrostatic effects - Human body model (HBM) electrostatic discharge test waveforms
- [3] **JESD22-A115C** — Electrostatic discharge (ESD) Sensitivity Testing Machine Model (MM)
- [4] **NX2-00001** — NXP Semiconductors Quality and Reliability Specification
- [5] **AN10439** — Wafer Level Chip Size Package
- [6] **AN10365** — Surface mount reflow soldering description

19. Revision history

Table 22. Revision history

Document ID	Release date	Data sheet status	Change notice	Supersedes
LD6806_SER v.3	20111209	Product data sheet	-	LD6806_SER v.2
Modifications:	<ul style="list-style-type: none"> • WLCSP4 package with backside coating added • SOT753 package added • Subtype LD6806x/xxP introduced • Minor text changes 			
LD6806_SER v.2	20110719	Product data sheet	-	LD6806_SER v.1
Modifications:	<ul style="list-style-type: none"> • Descriptive title updated • Table 5: title changed • Table 10: three parameters updated • Table 3: pin number updated • Section 9.4 and Section 9.8 drawings updated • Section 16: values updated • Minor text changes 			
LD6806_SER v.1	20110516	Preliminary data sheet	-	-

20. Legal information

20.1 Data sheet status

Document status ^{[1][2]}	Product status ^[3]	Definition
Objective [short] data sheet	Development	This document contains data from the objective specification for product development.
Preliminary [short] data sheet	Qualification	This document contains data from the preliminary specification.
Product [short] data sheet	Production	This document contains the product specification.

[1] Please consult the most recently issued document before initiating or completing a design.

[2] The term 'short data sheet' is explained in section "Definitions".

[3] The product status of device(s) described in this document may have changed since this document was published and may differ in case of multiple devices. The latest product status information is available on the Internet at URL <http://www.nxp.com>.

20.2 Definitions

Draft — The document is a draft version only. The content is still under internal review and subject to formal approval, which may result in modifications or additions. NXP Semiconductors does not give any representations or warranties as to the accuracy or completeness of information included herein and shall have no liability for the consequences of use of such information.

Short data sheet — A short data sheet is an extract from a full data sheet with the same product type number(s) and title. A short data sheet is intended for quick reference only and should not be relied upon to contain detailed and full information. For detailed and full information see the relevant full data sheet, which is available on request via the local NXP Semiconductors sales office. In case of any inconsistency or conflict with the short data sheet, the full data sheet shall prevail.

Product specification — The information and data provided in a Product data sheet shall define the specification of the product as agreed between NXP Semiconductors and its customer, unless NXP Semiconductors and customer have explicitly agreed otherwise in writing. In no event however, shall an agreement be valid in which the NXP Semiconductors product is deemed to offer functions and qualities beyond those described in the Product data sheet.

20.3 Disclaimers

Limited warranty and liability — Information in this document is believed to be accurate and reliable. However, NXP Semiconductors does not give any representations or warranties, expressed or implied, as to the accuracy or completeness of such information and shall have no liability for the consequences of use of such information.

In no event shall NXP Semiconductors be liable for any indirect, incidental, punitive, special or consequential damages (including - without limitation - lost profits, lost savings, business interruption, costs related to the removal or replacement of any products or rework charges) whether or not such damages are based on tort (including negligence), warranty, breach of contract or any other legal theory.

Notwithstanding any damages that customer might incur for any reason whatsoever, NXP Semiconductors' aggregate and cumulative liability towards customer for the products described herein shall be limited in accordance with the *Terms and conditions of commercial sale* of NXP Semiconductors.

Right to make changes — NXP Semiconductors reserves the right to make changes to information published in this document, including without limitation specifications and product descriptions, at any time and without notice. This document supersedes and replaces all information supplied prior to the publication hereof.

Suitability for use — NXP Semiconductors products are not designed, authorized or warranted to be suitable for use in life support, life-critical or safety-critical systems or equipment, nor in applications where failure or

malfunction of an NXP Semiconductors product can reasonably be expected to result in personal injury, death or severe property or environmental damage. NXP Semiconductors accepts no liability for inclusion and/or use of NXP Semiconductors products in such equipment or applications and therefore such inclusion and/or use is at the customer's own risk.

Applications — Applications that are described herein for any of these products are for illustrative purposes only. NXP Semiconductors makes no representation or warranty that such applications will be suitable for the specified use without further testing or modification.

Customers are responsible for the design and operation of their applications and products using NXP Semiconductors products, and NXP Semiconductors accepts no liability for any assistance with applications or customer product design. It is customer's sole responsibility to determine whether the NXP Semiconductors product is suitable and fit for the customer's applications and products planned, as well as for the planned application and use of customer's third party customer(s). Customers should provide appropriate design and operating safeguards to minimize the risks associated with their applications and products.

NXP Semiconductors does not accept any liability related to any default, damage, costs or problem which is based on any weakness or default in the customer's applications or products, or the application or use by customer's third party customer(s). Customer is responsible for doing all necessary testing for the customer's applications and products using NXP Semiconductors products in order to avoid a default of the applications and the products or of the application or use by customer's third party customer(s). NXP does not accept any liability in this respect.

Limiting values — Stress above one or more limiting values (as defined in the Absolute Maximum Ratings System of IEC 60134) will cause permanent damage to the device. Limiting values are stress ratings only and (proper) operation of the device at these or any other conditions above those given in the Recommended operating conditions section (if present) or the Characteristics sections of this document is not warranted. Constant or repeated exposure to limiting values will permanently and irreversibly affect the quality and reliability of the device.

Terms and conditions of commercial sale — NXP Semiconductors products are sold subject to the general terms and conditions of commercial sale, as published at <http://www.nxp.com/profile/terms>, unless otherwise agreed in a valid written individual agreement. In case an individual agreement is concluded only the terms and conditions of the respective agreement shall apply. NXP Semiconductors hereby expressly objects to applying the customer's general terms and conditions with regard to the purchase of NXP Semiconductors products by customer.

No offer to sell or license — Nothing in this document may be interpreted or construed as an offer to sell products that is open for acceptance or the grant, conveyance or implication of any license under any copyrights, patents or other industrial or intellectual property rights.

Export control — This document as well as the item(s) described herein may be subject to export control regulations. Export might require a prior authorization from competent authorities.

Non-automotive qualified products — Unless this data sheet expressly states that this specific NXP Semiconductors product is automotive qualified, the product is not suitable for automotive use. It is neither qualified nor tested in accordance with automotive testing or application requirements. NXP Semiconductors accepts no liability for inclusion and/or use of non-automotive qualified products in automotive equipment or applications.

In the event that customer uses the product for design-in and use in automotive applications to automotive specifications and standards, customer (a) shall use the product without NXP Semiconductors' warranty of the product for such automotive applications, use and specifications, and (b) whenever customer uses the product for automotive applications beyond

NXP Semiconductors' specifications such use shall be solely at customer's own risk, and (c) customer fully indemnifies NXP Semiconductors for any liability, damages or failed product claims resulting from customer design and use of the product for automotive applications beyond NXP Semiconductors' standard warranty and NXP Semiconductors' product specifications.

20.4 Trademarks

Notice: All referenced brands, product names, service names and trademarks are the property of their respective owners.

21. Contact information

For more information, please visit: <http://www.nxp.com>

For sales office addresses, please send an email to: salesaddresses@nxp.com

22. Tables

Table 1. Pin description for SOT753	2	outline WLCSP4; see Figure 35	19
Table 2. Pin description for WLCSP4	2	Table 13. Dimensions of LD6806CX4/Cxxx for package outline WLCSP4 with backside coating; see Figure 36	20
Table 3. Pin description for SOT886	2	Table 14. Dimensions of soldering footprint WLCSP4; see Figure 39	23
Table 4. Ordering information	3	Table 15. Lead-free process (from J-STD-020C)	25
Table 5. Type number and nominal output voltage of high-ohmic output	3	Table 16. SnPb eutectic process (from J-STD-020C)	28
Table 6. Type number and nominal output voltage of low-ohmic output	3	Table 17. Lead-free process (from J-STD-020C)	28
Table 7. Limiting values	5	Table 18. Recommended PCB design parameters	29
Table 8. Operating conditions	5	Table 19. Assembly recommendations	30
Table 9. Thermal characteristics	6	Table 20. Characteristics	30
Table 10. Electrical characteristics	6	Table 21. Abbreviations	31
Table 11. External load capacitor	18	Table 22. Revision history	32
Table 12. Dimensions of LD6806CX4/xxx for package			

23. Figures

Fig 1. Configuration for SOT753	2	Fig 34. Application diagram	18
Fig 2. Configuration for WLCSP4	2	Fig 35. Package outline WLCSP4	19
Fig 3. Configuration for SOT886	2	Fig 36. Package outline WLCSP4 with backside coating	20
Fig 4. Block diagram of LD6806x/xxH	4	Fig 37. Package outline SOT886 (XSON6)	21
Fig 5. Block diagram of LD6806x/xxP	4	Fig 38. SOT753; Plastic surface-mounted package; 5 leads	22
Fig 6. Dropout as a function of temperature for LD6806CX4/25H	8	Fig 39. Soldering footprint WLCSP4	23
Fig 7. Dropout as a function of temperature for LD6806F/25H	8	Fig 40. Soldering footprint SOT886 (XSON6)	23
Fig 8. Dropout as a function of temperature for LD6806CX4/36H	8	Fig 41. SOT753 (TSOP5); Reflow soldering footprint	24
Fig 9. Dropout as a function of temperature for LD6806F/36H	8	Fig 42. SOT753 (TSOP5); Wave soldering footprint	24
Fig 10. Dropout as a function of temperature for LD6806TD/36P	9	Fig 43. Temperature profiles for large and small components	26
Fig 11. Output voltage variation for LD6806CX4/12H	9	Fig 44. Temperature profiles for large and small components	29
Fig 12. Output voltage variation for LD6806CX4/25H	9	Fig 45. Pb-free solder reflow profile	30
Fig 13. Quiescent current for LD6806CX4/12H	10		
Fig 14. Quiescent current for LD6806CX4/25H	10		
Fig 15. Noise density for LD6806CX4/25H	11		
Fig 16. Noise density for LD6806CX4/36H	11		
Fig 17. Line regulation for LD6806CX4/12H	12		
Fig 18. Line regulation for LD6806F/12H	12		
Fig 19. Line regulation for LD6806CX4/25H	12		
Fig 20. Line regulation for LD6806F/25H	12		
Fig 21. Line regulation for LD6806CX4/36H	13		
Fig 22. Line regulation for LD6806F/36H	13		
Fig 23. Load regulation for LD6806CX4/12H	13		
Fig 24. Load regulation for LD6806F/12H	13		
Fig 25. Load regulation for LD6806CX4/25H	14		
Fig 26. Load regulation for LD6806F/25H	14		
Fig 27. Load regulation for LD6806CX4/36H	14		
Fig 28. Load regulation for LD6806F/36H	14		
Fig 29. Start-up for LD6806CX4/23H	15		
Fig 30. Shut down for LD6806F/25P	15		
Fig 31. PSRR for LD6806CX4/25H	16		
Fig 32. PSRR for LD6806CX4/36H	16		
Fig 33. Enable threshold voltage	17		

24. Contents

1	Product profile	1	16.1	PCB design guidelines	29
1.1	General description	1	16.2	PCB assembly guidelines for Pb-free soldering	30
1.2	Features and benefits	1	17	Abbreviations	31
1.3	Applications	2	18	References	31
2	Pinning information	2	19	Revision history	32
2.1	Pinning	2	20	Legal information	33
2.2	Pin description	2	20.1	Data sheet status	33
3	Ordering information	3	20.2	Definitions	33
3.1	Ordering options	3	20.3	Disclaimers	33
4	Block diagram	4	20.4	Trademarks	34
5	Limiting values	5	21	Contact information	34
6	Recommended operating conditions	5	22	Tables	35
7	Thermal characteristics	6	23	Figures	35
8	Characteristics	6	24	Contents	36
9	Dynamic behavior	7			
9.1	Dropout	7			
9.2	Output voltage variation	9			
9.3	Quiescent current	10			
9.4	Noise	11			
9.5	Line regulation	12			
9.6	Load regulation	13			
9.7	Start-up and shut down	15			
9.8	Power Supply Rejection Ratio (PSRR)	16			
9.9	Enable threshold voltage	17			
10	Application information	18			
10.1	Output capacitor values	18			
11	Test information	18			
11.1	Quality information	18			
12	Package outline	19			
13	Soldering	23			
14	Soldering of WLCSP packages	24			
14.1	Introduction to soldering WLCSP packages	24			
14.2	Board mounting	25			
14.3	Reflow soldering	25			
14.3.1	Stand off	26			
14.3.2	Quality of solder joint	26			
14.3.3	Rework	26			
14.3.4	Cleaning	27			
15	Soldering of SMD packages	27			
15.1	Introduction to soldering	27			
15.2	Wave and reflow soldering	27			
15.3	Wave soldering	28			
15.4	Reflow soldering	28			
16	Mounting	29			

Please be aware that important notices concerning this document and the product(s) described herein, have been included in section 'Legal information'.

© NXP B.V. 2011. All rights reserved.

For more information, please visit: <http://www.nxp.com>
 For sales office addresses, please send an email to: salesaddresses@nxp.com

Date of release: 9 December 2011
 Document identifier: LD6806_SER



Looking for pricing, stock, or lifecycle information?

Click below to explore more details on WIN SOURCE:

 [View LD6806F/33H,115 on WIN SOURCE](#)

 [NXP / Nexperia Information](#)

Optimize Your Supply Chain with WIN SOURCE Solutions

-  Global Sourcing Solution
-  Obsolete Management
-  Cost Control Management
-  Shortage Management
-  Alternative Solution
-  Excess Inventory Management