



Is Now Part of



ON Semiconductor®

To learn more about ON Semiconductor, please visit our website at
www.onsemi.com

Please note: As part of the Fairchild Semiconductor integration, some of the Fairchild orderable part numbers will need to change in order to meet ON Semiconductor's system requirements. Since the ON Semiconductor product management systems do not have the ability to manage part nomenclature that utilizes an underscore (_), the underscore (_) in the Fairchild part numbers will be changed to a dash (-). This document may contain device numbers with an underscore (_). Please check the ON Semiconductor website to verify the updated device numbers. The most current and up-to-date ordering information can be found at www.onsemi.com. Please email any questions regarding the system integration to Fairchild_questions@onsemi.com.

ON Semiconductor and the ON Semiconductor logo are trademarks of Semiconductor Components Industries, LLC dba ON Semiconductor or its subsidiaries in the United States and/or other countries. ON Semiconductor owns the rights to a number of patents, trademarks, copyrights, trade secrets, and other intellectual property. A listing of ON Semiconductor's product/patent coverage may be accessed at www.onsemi.com/site/pdf/Patent-Marking.pdf. ON Semiconductor reserves the right to make changes without further notice to any products herein. ON Semiconductor makes no warranty, representation or guarantee regarding the suitability of its products for any particular purpose, nor does ON Semiconductor assume any liability arising out of the application or use of any product or circuit, and specifically disclaims any and all liability, including without limitation special, consequential or incidental damages. Buyer is responsible for its products and applications using ON Semiconductor products, including compliance with all laws, regulations and safety requirements or standards, regardless of any support or applications information provided by ON Semiconductor. "Typical" parameters which may be provided in ON Semiconductor data sheets and/or specifications can and do vary in different applications and actual performance may vary over time. All operating parameters, including "Typicals" must be validated for each customer application by customer's technical experts. ON Semiconductor does not convey any license under its patent rights nor the rights of others. ON Semiconductor products are not designed, intended, or authorized for use as a critical component in life support systems or any FDA Class 3 medical devices or medical devices with a same or similar classification in a foreign jurisdiction or any devices intended for implantation in the human body. Should Buyer purchase or use ON Semiconductor products for any such unintended or unauthorized application, Buyer shall indemnify and hold ON Semiconductor and its officers, employees, subsidiaries, affiliates, and distributors harmless against all claims, costs, damages, and expenses, and reasonable attorney fees arising out of, directly or indirectly, any claim of personal injury or death associated with such unintended or unauthorized use, even if such claim alleges that ON Semiconductor was negligent regarding the design or manufacture of the part. ON Semiconductor is an Equal Opportunity/Affirmative Action Employer. This literature is subject to all applicable copyright laws and is not for resale in any manner.

FSQ0370RNA, FSQ0370RLA

Green Mode Fairchild Power Switch (FPS™)

Features

- Internal Avalanche Rugged 700V SenseFET
- Consumes Only 0.8W at 230V_{AC} & 0.5W Load with Burst-Mode Operation
- Precision Fixed Operating Frequency: 100kHz
- Internal Startup Circuit and Built-in Soft-Start
- Pulse-by-Pulse Current Limiting, Auto-Restart Mode
- Over-Voltage Protection (OVP), Overload Protection (OLP), Internal Thermal Shutdown Function (TSD)
- Under-Voltage Lockout (UVLO)
- Low Operating Current: 3mA
- Adjustable Peak Current Limit

Applications

- Auxiliary Power Supply for PC and Server
- SMPS for VCR, SVR, STB, DVD, and DVCD Player
- Printer, Facsimile, and Scanner
- Adapter for Camcorder

Description

The FSQ0370 consists of an integrated Current Mode Pulse Width Modulator (PWM) and an avalanche rugged 700V SenseFET. It is specifically designed for high-performance offline Switched Mode Power Supplies (SMPS) with minimal external components. The integrated PWM controller features include: a fixed-frequency generating oscillator, Under-Voltage Lockout (UVLO) protection, Leading-Edge Blanking (LEB), an optimized gate turn-on / turn-off driver, Thermal Shutdown (TSD) protection, and temperature-compensated precision current sources for loop compensation and fault protection circuitry.

Compared to a discrete MOSFET and controller or RCC switching converter solution, the FSQ0370 reduces total component count, design size, and weight while increasing efficiency, productivity, and system reliability. These devices provide a basic platform that is well suited for the design of cost-effective flyback converters, such as in PC auxiliary power supplies.

Related Application Notes

- [AN-4134 — Design Guidelines for Off-line Forward Converters Using Fairchild Power Switch \(FPS™\)](#)
- [AN-4137 — Design Guidelines for Offline Flyback Converters Using Fairchild Power Switch \(FPS™\)](#)
- [AN-4141 — Troubleshooting and Design Tips for Fairchild Power Switch \(FPS™\) Flyback Applications](#)
- [AN-4147 — Design Guidelines for RCD Snubber of Flyback Converters](#)

Ordering Information

Part Number	Package	Marking Code	BV _{DSS}	f _{osc}	R _{DS(ON)(MAX)}
FSQ0370RNA	8-Lead, Dual Inline Package (DIP)	Q0370RA	700V	100KHz	4.75Ω
FSQ0370RLA	8-Lead, LSOP				

Pin Assignments

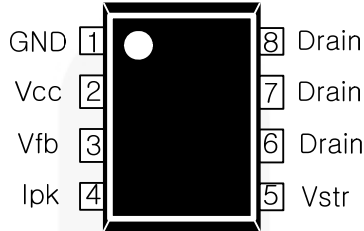

Figure 3. Pin Configuration (Top View)

Pin Definitions

Pin#	Name	Description
1	GND	SenseFET source terminal on the primary side and internal control ground.
2	V _{cc}	Positive supply voltage input. Although connected to an auxiliary transformer winding, current is supplied from pin 5 (V _{str}) via an internal switch during startup (see Figure 2). It is not until V _{CC} reaches the UVLO upper threshold (12V) that the internal startup switch opens and device power is supplied via the auxiliary transformer winding.
3	V _{fb}	The feedback voltage pin is the non-inverting input to the PWM comparator. It has a 0.9mA current source connected internally, while a capacitor and optocoupler are typically connected externally. A feedback voltage of 6V triggers overload protection (OLP). There is a delay while charging external capacitor C _{fb} from 3V to 6V using an internal 5μA current source. This delay prevents false triggering under transient conditions, but allows the protection mechanism to operate in true overload conditions.
4	I _{pk}	This pin adjusts the peak current limit of the SenseFET. The 0.9mA feedback current source is diverted to the parallel combination of an internal 2.8kΩ resistor and any external resistor to GND on this pin. This determines the peak current limit. If this pin is tied to V _{cc} or left floating, the typical peak current limit is 1.1A.
5	V _{str}	This pin is connected to the rectified AC line voltage source. At startup, the internal switch supplies internal bias and charges an external storage capacitor placed between the V _{cc} pin and ground. Once V _{CC} reaches 12V, the internal switch is opened.
6, 7, 8	Drain	The drain pins are designed to connect directly to the primary lead of the transformer and are capable of switching a maximum of 700V. Minimizing the length of the trace connecting these pins to the transformer decreases leakage inductance.

Absolute Maximum Ratings

Stresses exceeding the absolute maximum ratings may damage the device. The device may not function or be operable above the recommended operating conditions and stressing the parts to these levels is not recommended. In addition, extended exposure to stresses above the recommended operating conditions may affect device reliability. The absolute maximum ratings are stress ratings only. $T_A=25^{\circ}\text{C}$, unless otherwise specified.

Symbol	Parameter	Min.	Max.	Unit
V_{DRAIN}	Drain Pin Voltage	700		V
V_{STR}	Vstr Pin Voltage	700		V
I_{DM}	Drain Current Pulsed ⁽⁵⁾		12	A
E_{AS}	Single Pulsed Avalanche Energy ⁽⁶⁾		230	mJ
V_{CC}	Supply Voltage		20	V
V_{FB}	Feedback Voltage Range	-0.3	V_{CC}	V
P_{D}	Total Power Dissipation		1.5	W
T_{J}	Recommended Operating Junction Temperature	-40	Internally Limited	$^{\circ}\text{C}$
T_{A}	Operating Ambient Temperature	-40	+85	$^{\circ}\text{C}$
T_{STG}	Storage Temperature	-55	+150	$^{\circ}\text{C}$

Notes:

5. Non-repetitive rating; pulse-width limited by maximum junction temperature.
6. $L=51\text{mH}$, starting $T_{\text{J}}=25^{\circ}\text{C}$.

Thermal Impedance

Symbol	Parameter	Value	Unit
θ_{JA}	Junction-to-Ambient Thermal Resistance ⁽⁷⁾	80	$^{\circ}\text{C}/\text{W}$
θ_{JC}	Junction-to-Case Thermal Resistance ⁽⁸⁾	20	
Ψ_{JT}	Junction-to-Top Thermal Resistance ⁽⁹⁾	35	

Notes:

7. Free-standing with no heat-sink, without copper clad.
8. Measured on the drain pin, close to the plastic interface.
9. Measured on the package top surface.

Electrical Characteristics

T_A=25°C unless otherwise specified.

Symbol	Parameter	Condition	Min.	Typ.	Max.	Unit
SenseFET Section⁽¹⁰⁾						
I _{DSS}	Zero-Gate-Voltage Drain Current	V _{DS} =700V, V _{GS} =0V			50	μA
		V _{DS} =560V, V _{GS} =0V, T _C =125°C			200	
R _{DS(ON)}	Drain-Source On-State Resistance ⁽¹⁰⁾	V _{GS} =10V, I _D =0.5A		4.00	4.75	Ω
C _{ISS}	Input Capacitance	V _{GS} =0V, V _{DS} =25V, f=1MHz		315		pF
C _{OSS}	Output Capacitance	V _{GS} =0V, V _{DS} =25V, f=1MHz		47		pF
C _{RSS}	Reverse Transfer Capacitance	V _{GS} =0V, V _{DS} =25V, f=1MHz		9		pF
t _{d(on)}	Turn-On Delay	V _{DD} =350V, I _D =1A		11.2		ns
t _r	Rise Time	V _{DD} =350V, I _D =1A		34		ns
t _{d(off)}	Turn-Off Delay	V _{DD} =350V, I _D =1A		28.2		ns
t _f	Fall Time	V _{DD} =350V, I _D =1A		32		ns
Control Section						
f _{OSC}	Switching Frequency		92	100	108	kHz
Δf _{OSC}	Switching Frequency Variation ⁽¹¹⁾	-25°C < T _J < 85°C		±5	±10	%
D _{MAX}	Maximum Duty Cycle	Measured at 0.1 x V _{DS}	55	60	650	%
D _{MIN}	Minimum Duty Cycle		0	0	0	%
V _{START}	UVLO Threshold Voltage	V _{FB} =GND	11	12	13	V
V _{STOP}			7	8	9	
I _{FB}	Feedback Source Current	V _{FB} =GND	0.7	0.9	1.1	mA
t _{S/S}	Internal Soft-Start Time ⁽¹¹⁾	V _{FB} =4V		10		ms
Burst-Mode Section						
V _{BURH}	Burst-Mode Voltage	T _J =25°C	0.5	0.6	07	V
V _{BURL}			0.3	0.4	0.5	V
V _{BUR(HYS)}			100	200	300	mV
Protection Section						
I _{LIM}	Peak Current Limit	di/dt=240mA/μs	0.97	1.10	1.23	A
t _{CLD}	Current Limit Delay ⁽¹¹⁾			500		ns
T _{SD}	Thermal Shutdown Temperature ⁽¹¹⁾		125	140		°C
V _{SD}	Shutdown Feedback Voltage		5.5	6.0	6.5	V
V _{OVP}	Over-Voltage Protection		18	19		V
I _{DELAY}	Shutdown Delay Current	V _{FB} =4V	3.5	5.0	6.5	μA
t _{LEB}	Leading-Edge Blanking Time ⁽¹¹⁾		200			ns
Total Device Section						
I _{OP}	Operating Supply Current (Control Part Only)	V _{CC} =14V	1	3	5	mA
I _{CH}	Startup Charging Current	V _{CC} =0V	0.70	0.85	1.00	mA
V _{STR}	V _{STR} Supply Voltage	V _{CC} =0V		24		V

Notes:

10. Pulse test: Pulse width ≤ 300μs, duty ≤ 2%.

11. These parameters, although guaranteed, are not 100% tested in production.

Typical Performance Characteristics

Characteristic graphs are normalized at $T_A=25^\circ\text{C}$.

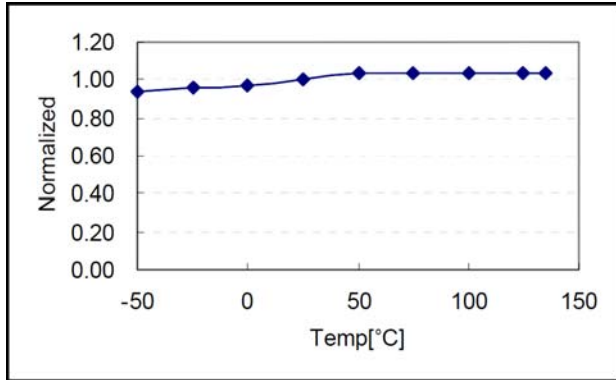

Figure 4. Operating Frequency (f_{osc}) vs. T_A

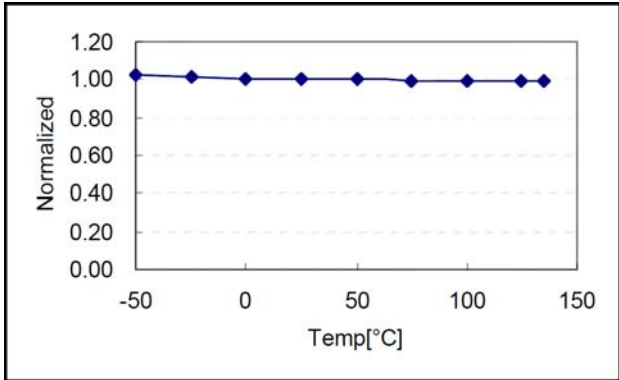

Figure 5. Over-Voltage Protection (V_{OVP}) vs. T_A

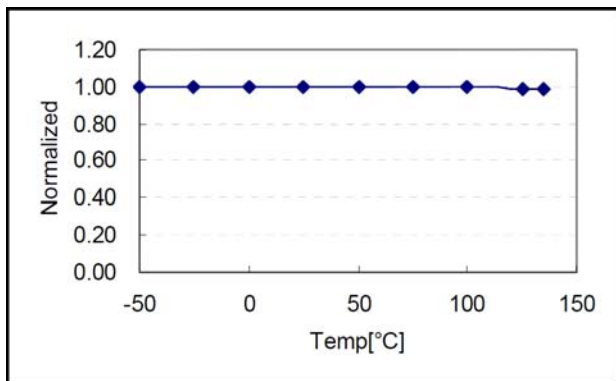

Figure 6. Maximum Duty Cycle (D_{MAX}) vs. T_A

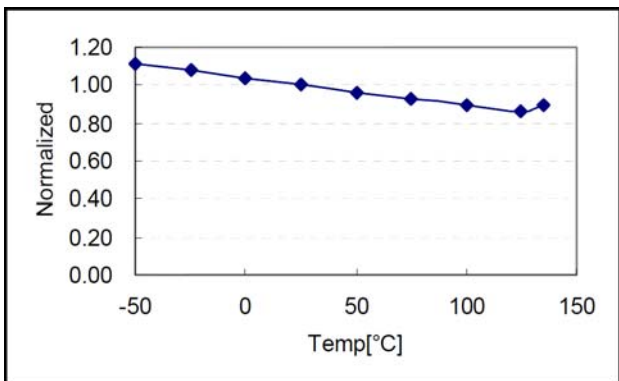

Figure 7. Operating Supply Current (I_{OP}) vs. T_A

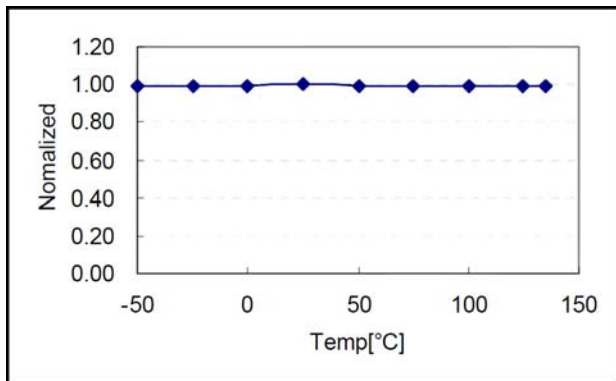

Figure 8. Start Threshold Voltage (V_{START}) vs. T_A

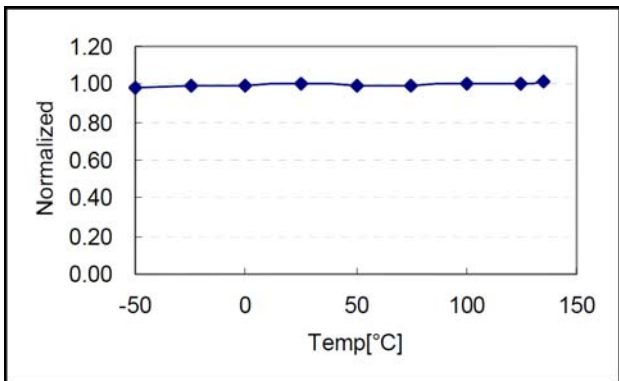

Figure 9. Stop Threshold Voltage (V_{STOP}) vs. T_A

Typical Performance Characteristics

Characteristic graphs are normalized at $T_A=25^\circ\text{C}$.

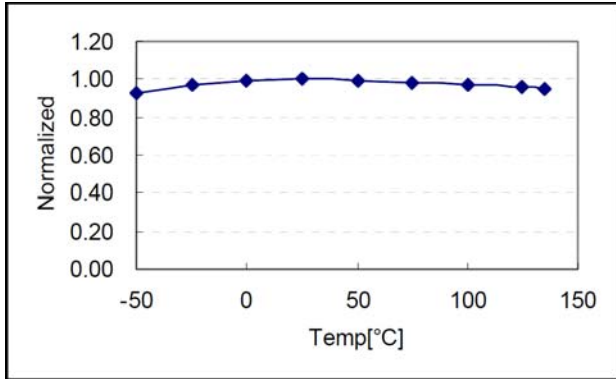

Figure 10. Feedback Source Current (I_{FB}) vs. T_A

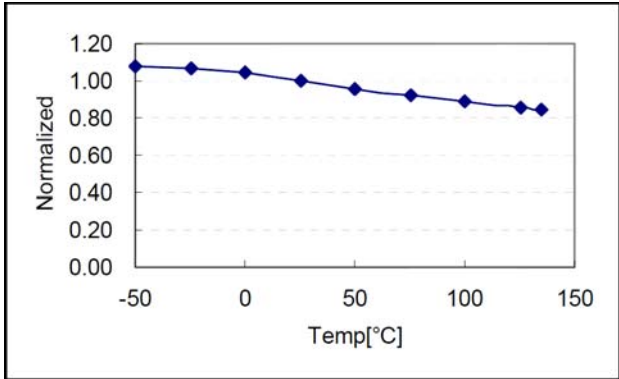

Figure 11. Startup Charging Current (I_{CH}) vs. T_A

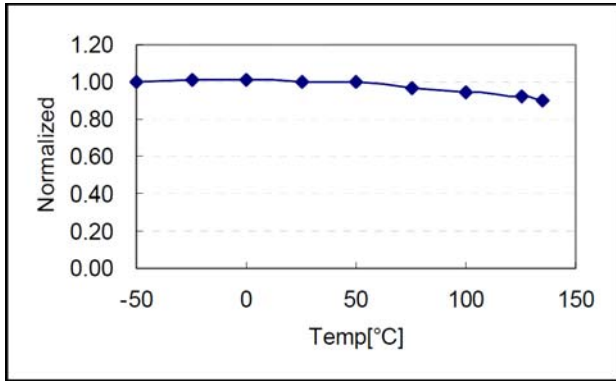

Figure 12. Peak Current Limit (I_{LIM}) vs. T_A



4.2 Thermal Shutdown (TSD): The SenseFET and the control IC are integrated, making it easier for the control IC to detect the temperature of the SenseFET. If the temperature exceeds approximately 140°C, thermal shutdown is activated.

4.3 Over-Voltage Protection (OVP): In the event of a malfunction in the secondary-side feedback circuit or an open feedback loop caused by a soldering defect, the current through the optocoupler transistor becomes almost zero (refer to Figure 14). Then, V_{FB} climbs up in a similar manner to the overload situation, forcing the preset maximum current to be supplied to the SMPS until the overload protection is activated. Because excess energy is provided to the output, the output voltage may exceed the rated voltage before the overload protection is activated, resulting in the breakdown of the devices in the secondary side. To prevent this situation, an Over-Voltage Protection (OVP) circuit is employed. In general, V_{CC} is proportional to the output voltage and the FPS uses V_{CC} instead of directly monitoring the output voltage. If V_{CC} exceeds 19V, the OVP circuit is activated, terminating switching. To avoid undesired activation of OVP during normal operation, V_{CC} should be designed to be below 19V.

5. Soft-Start: The FPS internal soft-start circuit slowly increases the SenseFET current after startup, as shown in Figure 16. The typical soft-start time is 10ms, where progressive increments of the SenseFET current are allowed during the startup phase. The pulse width to the power switching device is progressively increased to establish the correct working conditions for transformers, inductors, and capacitors. The voltage on the output capacitors is progressively increased to smoothly establish the required output voltage. This helps to prevent transformer saturation and reduces the stress on the secondary diode during startup.

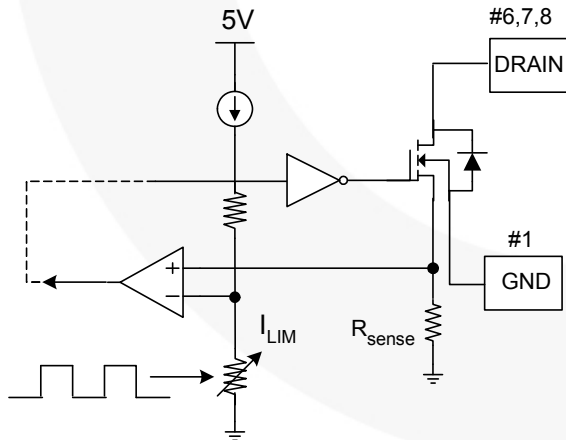

Figure 16. Soft-Start Function

6. Burst Operation: To minimize power dissipation in Standby Mode, the FPS enters Burst Mode. Feedback voltage decreases as the load decreases and, as shown in Figure 17, the device automatically enters Burst Mode when the feedback voltage drops below V_{BURH} (typically 600mV). Switching continues until the feedback voltage drops below V_{BURL} (typically 400mV). At this point, switching stops and the output voltage starts to drop at a rate dependent on the standby current load. This causes the feedback voltage to rise. Once it passes V_{BURH} , switching resumes. The feedback voltage then falls and the process is repeated. Burst Mode alternately enables and disables switching of the SenseFET and reduces switching loss in Standby Mode.

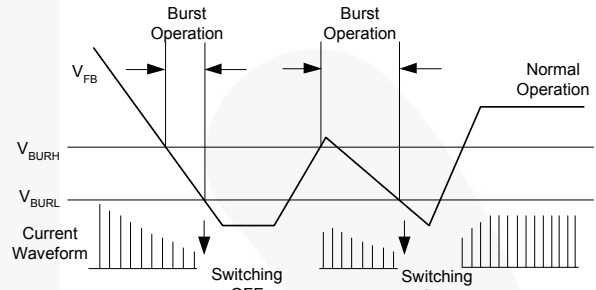

Figure 17. Burst Operation Function

7. Adjusting Peak Current Limit: As shown in Figure 18, a combined 2.8kΩ internal resistance is connected to the non-inverting lead on the PWM comparator. An external resistance of R_x on the current limit pin forms a parallel resistance with the 2.8kΩ when the internal diodes are biased by the main current source of 900μA.

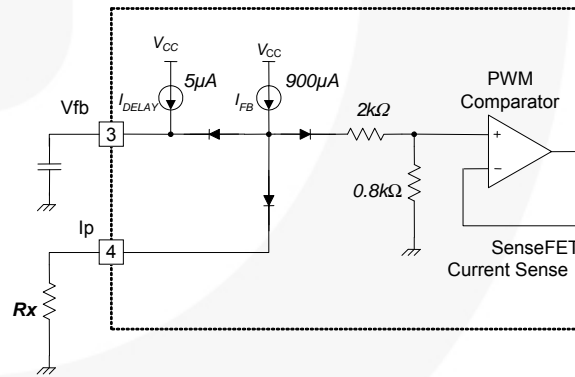

Figure 18. Peak Current Limit Adjustment

For example, FSQ0370 has a typical SenseFET peak current limit (I_{LIM}) of 1.1A. I_{LIM} can be adjusted to 0.6A by inserting R_x between the I_{pk} pin and the ground. The value of the R_x can be estimated by:

$$1.1A : 0.6A = 2.8k\Omega : Xk\Omega, \quad (1)$$

$$X = R_x \parallel 2.8k\Omega. \quad (2)$$

where X represents the resistance of the parallel network.

Application Information

Reducing Audible Noise

Switching mode power converters have electronic and magnetic components that generate audible noises when the operating frequency is in the range of 20~20,000Hz. Even though they operate above 20KHz, they can create noise, depending on the load condition. Three methods of reducing noise are discussed below:

Glue or Varnish

The most common method of reducing audible noise includes using glue or varnish to tighten magnetic components. The motion of core, bobbin, and coil as well as the chattering or magnetostriction of core can cause the transformer to produce audible noise. The use of rigid glue and varnish reduces the transformer noise. Glue or varnish can also crack the core because sudden changes in the ambient temperature cause the core and the glue to expand or shrink in a different ratio according to the temperature.

Ceramic Capacitor

Using a film capacitor instead of a ceramic capacitor as a snubber capacitor is another noise reduction solution. Some dielectric materials show a piezoelectric effect, depending on the electric field intensity. A snubber capacitor can become one of the most significant sources of audible noise. Another possibility is to use a Zener clamp circuit instead of an RCD snubber for higher efficiency as well as lower audible noise.

Adjusting Sound Frequency

Moving the fundamental frequency of noise out of 2~4KHz range is a third method. Generally, humans are more sensitive to noise in the range of 2~4KHz. When the fundamental frequency of noise is located in this range, the noise sounds louder though the noise intensity level is identical. Refer to Figure 19.

If Burst Mode is suspected as a source of noise, this method may be helpful. If the frequency of Burst Mode operation lies in the range of 2~4KHz, adjusting the feedback loop can shift the burst operation frequency. To reduce burst operation frequency, increase a feedback gain capacitor (C_F), optocoupler supply resistor (R_D), and feedback capacitor (C_B) and decrease a feedback gain resistor (R_F) as shown in Figure 20.

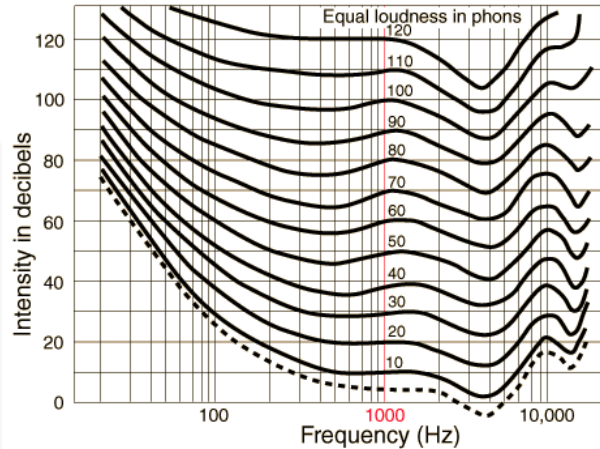

Figure 19. Equal Loudness Curves

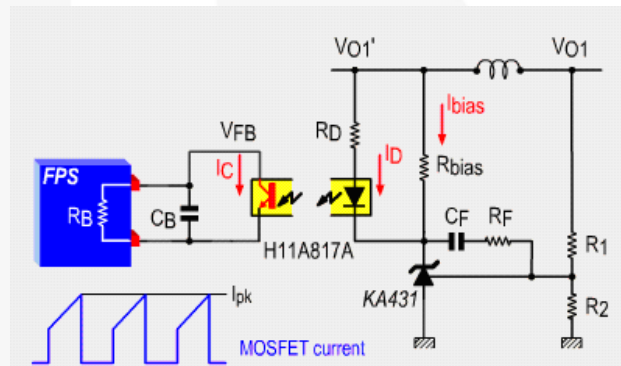

Figure 20. Typical Feedback Network of FPS™

Reference Materials

[AN-4134 — Design Guidelines for Offline Forward Converters Using Fairchild Power Switch \(FPS™\)](#)

[AN-4137 — Design Guidelines for Offline Flyback Converters Using Fairchild Power Switch \(FPS™\)](#)

[AN-4140 — Transformer Design Consideration for Offline Flyback Converters Using Fairchild Power Switch \(FPS™\)](#)

[AN-4141 — Troubleshooting and Design Tips for Fairchild Power Switch \(FPS™\) Flyback Applications](#)

[AN-4147 — Design Guidelines for RCD Snubber of Flyback Converters](#)

[AN-4148 — Audible Noise Reduction Techniques for FPS Applications](#)

Typical Application Circuit

Application	Output Power	Input Voltage	Output Voltage (Maximum Current)
PC Auxiliary Power Supply (Using FSQ0270RNA)	15W	Universal Input (85-264V _{AC})	5V (3A)

Features

- High efficiency (>78% at 115V_{AC} and 230V_{AC} input)
- Low Standby Mode power consumption (<0.8W at 230V_{AC} input and 0.5W load)
- Enhanced system reliability through various protection functions
- Low EMI through frequency modulation
- Internal soft-start: 10ms
- Line UVLO function can be achieved using external components

Key Design Notes

- The delay for overload protection is designed to be about 30ms with C8 of 47nF. If faster/slower triggering of OLP is required, C8 can be changed to a smaller or larger value (eg. 100nF for 60ms).
- ZP1, DL1, RL1, RL2, RL3, RL4, RL5, RL7, QL1, QL2, and CL9 build a line Under-Voltage Lockout block (UVLO). The Zener voltage of ZP1 determines the input voltage that turns the FPS on. RL5 and DL1 provide a reference voltage from V_{CC}. If the input voltage divided by RL1, RL2, and RL4 is lower than the Zener voltage of DL1; QL1, and QL2 turn on and pull V_{fb} down to ground.
- An evaluation board and corresponding test report can be provided. Contact a Fairchild representative.

Transformer

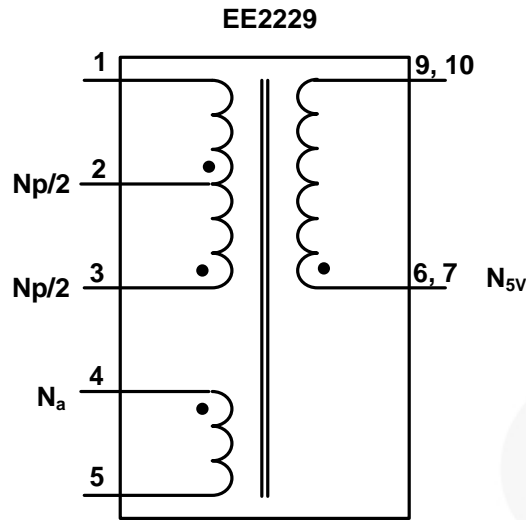

Figure 22. Transformer Schematic Diagram

Table 2. Winding Specification

No.	Pin (s→f)	Wire	Turns	Winding Method
$N_p/2$	3 → 2	0.3 ^ø x 1	72	Solenoid Winding
Insulation: Polyester Tape t = 0.025mm, 1-Layer				
N_a	4 → 5	0.25 ^ø x 2	22	Solenoid Winding
Insulation: Polyester Tape t = 0.025mm, 2-Layer				
N_{5V}	6, 7 → 9, 10	0.65 ^ø x 2	8	Solenoid Winding
Insulation: Polyester Tape t = 0.025mm, 2-Layer				
$N_p/2$	2 → 1	0.3 ^ø x 1	72	Solenoid Winding
Insulation: Polyester Tape t = 0.025mm, 2-Layer				

Table 3. Electrical Characteristics

	Pin	Specification	Remarks
Inductance	1 - 3	1.20mH ± 5%	100kHz, 1V
Leakage	1 - 3	<30μH Maximum	Short All Other Pins

Core & Bobbin

- Core: EER2229 (PL-7, 37.2mm²)
- Bobbin: BE2229

Table 4. Demonstration Board Part List

Part Number	Value	Quantity	Description (Manufacturer)
C6, C8	47nF	2	Ceramic Capacitor
C1	2.2nF (1KV)	1	AC Ceramic Capacitor(X1 & Y1)
C10	1nF (200V)	1	Mylar Capacitor
CS1	1.5nF (50V)	1	SMD Ceramic Capacitor
C2, C3	22µF (400V)	2	Low Impedance Electrolytic Capacitor KMX series (Samyoung Electronics)
C4, C9	1000µF (16V)	2	Low ESR Electrolytic Capacitor NXC series (Samyoung Electronics)
C5	470µF (10V)	1	Low ESR Electrolytic Capacitor NXC series (Samyoung Electronics)
C7	47µF (25V)	1	General Electrolytic Capacitor
CL9	10µF (50V)	1	General Electrolytic Capacitor
L1	330µH	1	Inductor
L2	1µH	1	Inductor
R6	2.4 (1W)	1	Fusible Resistor
J1, J2, J4, L3	0	4	Jumper
R2	4.7kΩ	1	Resistor
R3	560Ω	1	Resistor
R4	100Ω	1	Resistor
R5	1.25kΩ	1	Resistor
R11	1.2kΩ	1	Resistor
R9	10kΩ	1	Resistor
R10	2Ω	1	Resistor
R14	30Ω	1	Resistor
RL3	1kΩ	1	Resistor
RL1, RL2	1MΩ	2	Resistor
RL4	120kΩ	1	Resistor
RL5	30kΩ	1	Resistor
RL7	40kΩ	1	Resistor
RS1	9Ω	1	Resistor
ZR1	80Ω	1	SMD Resistor
U1	FOD817A	1	IC (Fairchild Semiconductor)
U2	TL431	1	IC (Fairchild Semiconductor)
U3	FSQ0270RNA	1	IC (Fairchild Semiconductor)
QL1	2N2907	1	IC (Fairchild Semiconductor)
QL2	2N2222	1	IC (Fairchild Semiconductor)
D2, D3, D4, D5, D6, DS1	1N4007	6	Diode (Fairchild Semiconductor)
D1	SB540	1	Schottky Diode (Fairchild Semiconductor)
ZD1	1N4745	1	Zener Diode (Fairchild Semiconductor)
DL1	1N5233	1	Zener Diode (Fairchild Semiconductor)
ZP1	82V (1W)	1	Zener Diode (Fairchild Semiconductor)
ZDS1	P6KE180A	1	TVS (Fairchild Semiconductor)

Layout

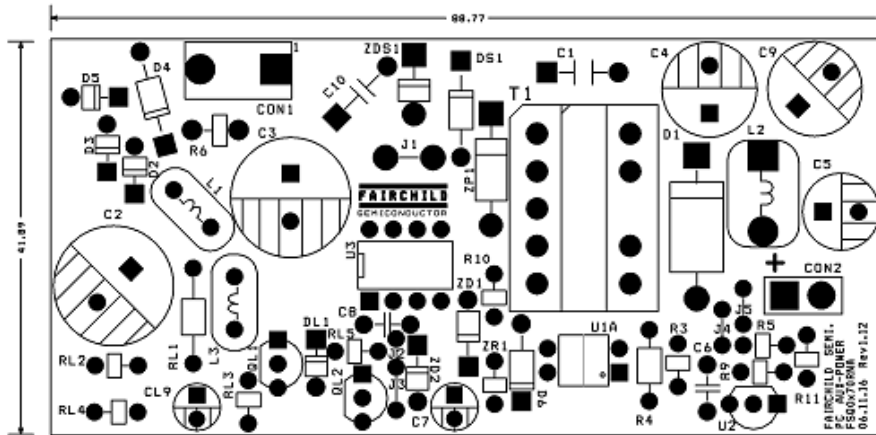

Figure 23. Top Image of PCB

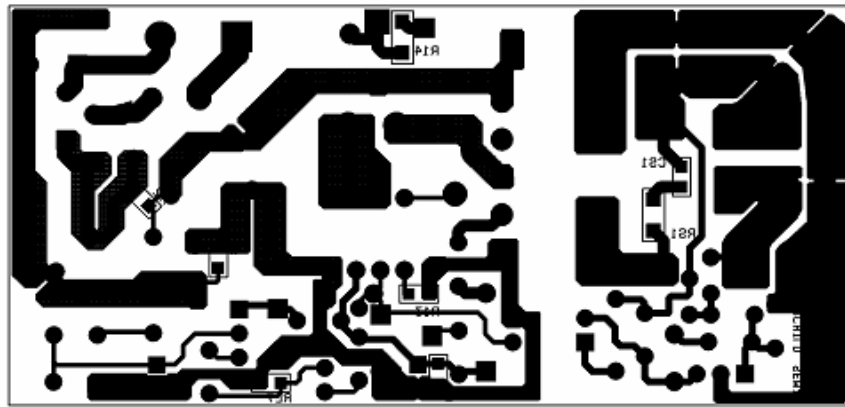
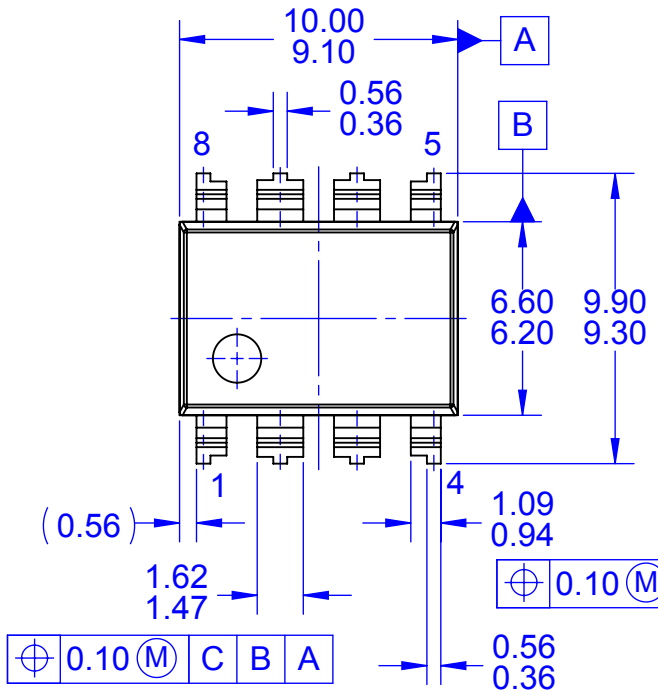
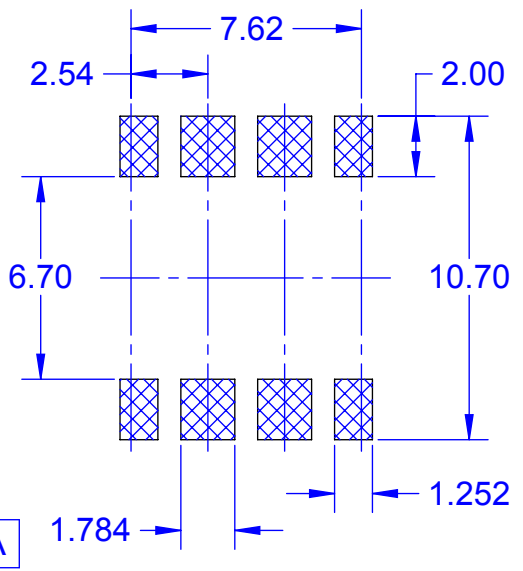

Figure 24. Bottom of Image of PCB





TOP VIEW



LAND PATTERN RECOMMENDATION

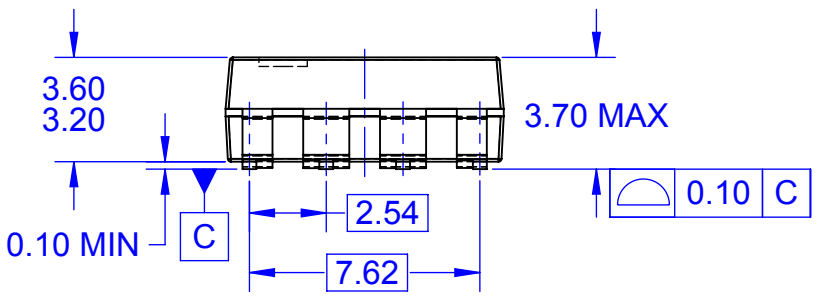

FRONT VIEW

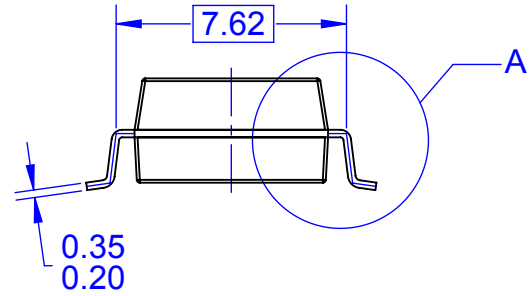

SIDE VIEW

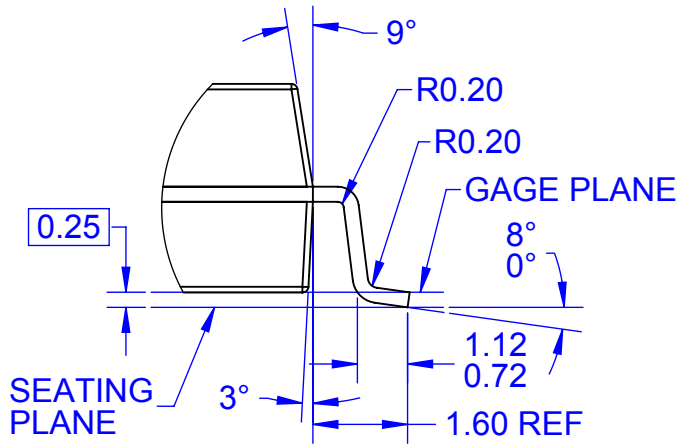

DETAIL A
SCALE 2:1

- NOTES: UNLESS OTHERWISE SPECIFIED
 A. NO INDUSTRY STANDARD APPLIES TO THIS PACKAGE
 B. ALL DIMENSIONS ARE IN MILLIMETERS
 C. DIMENSIONS ARE EXCLUSIVE OF BURRS, MOLD FLASH, AND TIE BAR EXTRUSIONS
 D. DIMENSIONS AND TOLERANCES PER ASME Y14.5M-2009
 E. DRAWING FILENAME: MKT-MLSOP08Arev2



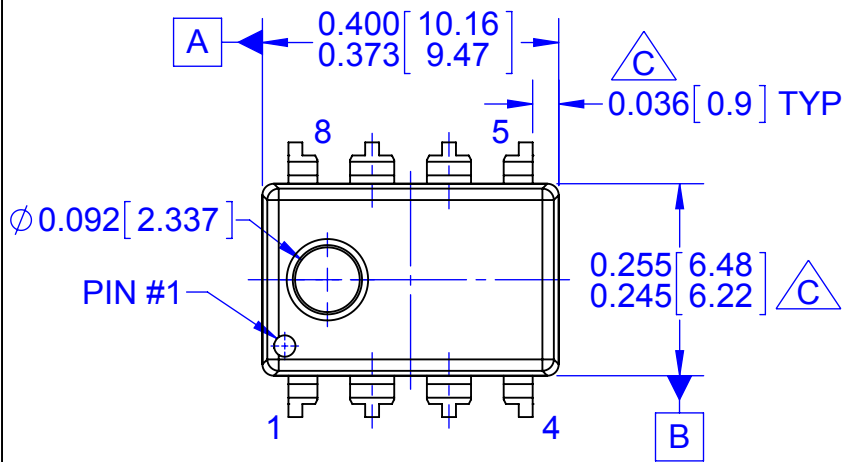

TOP VIEW, OPTION 1

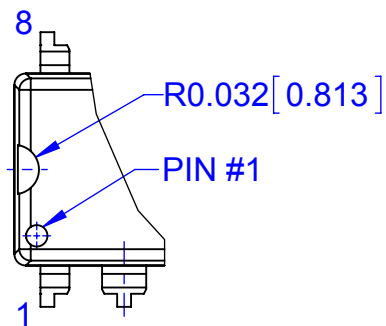

TOP VIEW, OPTION 2

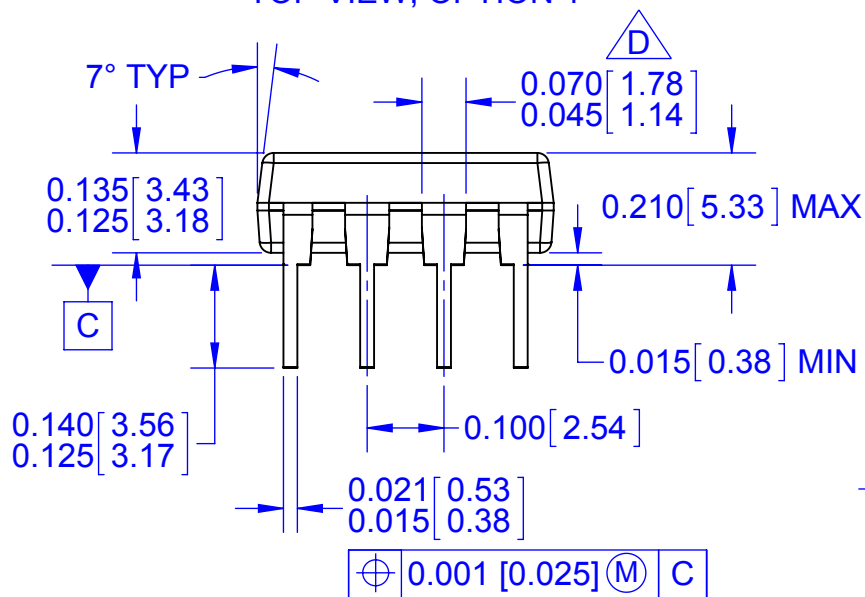

FRONT VIEW

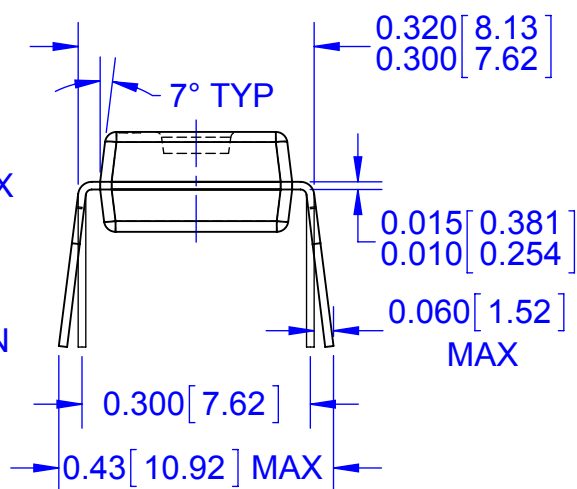

SIDE VIEW

NOTES:

- A. CONFORMS TO JEDEC MS-001, VARIATION BA
- B. CONTROLLING DIMENSIONS ARE IN INCHES.
REFERENCE DIMENSIONS ARE IN MILLIMETERS.

C DOES NOT INCLUDE MOLD FLASH OR PROTRUSIONS.
MOLD FLASH OR PROTRUSIONS SHALL NOT EXCEED
0.010 INCHES OR 0.25MM.

D DOES NOT INCLUDE DAMBAR PROTRUSIONS.
DAMBAR PROTRUSIONS SHALL NOT EXCEED 0.010
INCHES OR 0.25MM.

E. DIMENSIONING AND TOLERANCING PER ASME
Y14.5M-2009

F. DRAWING FILENAME: MKT-N08Erev8



ON Semiconductor and  are trademarks of Semiconductor Components Industries, LLC dba ON Semiconductor or its subsidiaries in the United States and/or other countries. ON Semiconductor owns the rights to a number of patents, trademarks, copyrights, trade secrets, and other intellectual property. A listing of ON Semiconductor's product/patent coverage may be accessed at www.onsemi.com/site/pdf/Patent-Marking.pdf. ON Semiconductor reserves the right to make changes without further notice to any products herein. ON Semiconductor makes no warranty, representation or guarantee regarding the suitability of its products for any particular purpose, nor does ON Semiconductor assume any liability arising out of the application or use of any product or circuit, and specifically disclaims any and all liability, including without limitation special, consequential or incidental damages. Buyer is responsible for its products and applications using ON Semiconductor products, including compliance with all laws, regulations and safety requirements or standards, regardless of any support or applications information provided by ON Semiconductor. "Typical" parameters which may be provided in ON Semiconductor data sheets and/or specifications can and do vary in different applications and actual performance may vary over time. All operating parameters, including "Typicals" must be validated for each customer application by customer's technical experts. ON Semiconductor does not convey any license under its patent rights nor the rights of others. ON Semiconductor products are not designed, intended, or authorized for use as a critical component in life support systems or any FDA Class 3 medical devices or medical devices with a same or similar classification in a foreign jurisdiction or any devices intended for implantation in the human body. Should Buyer purchase or use ON Semiconductor products for any such unintended or unauthorized application, Buyer shall indemnify and hold ON Semiconductor and its officers, employees, subsidiaries, affiliates, and distributors harmless against all claims, costs, damages, and expenses, and reasonable attorney fees arising out of, directly or indirectly, any claim of personal injury or death associated with such unintended or unauthorized use, even if such claim alleges that ON Semiconductor was negligent regarding the design or manufacture of the part. ON Semiconductor is an Equal Opportunity/Affirmative Action Employer. This literature is subject to all applicable copyright laws and is not for resale in any manner.

PUBLICATION ORDERING INFORMATION

LITERATURE FULFILLMENT:

Literature Distribution Center for ON Semiconductor
19521 E. 32nd Pkwy, Aurora, Colorado 80011 USA
Phone: 303-675-2175 or 800-344-3860 Toll Free USA/Canada
Fax: 303-675-2176 or 800-344-3867 Toll Free USA/Canada
Email: orderlit@onsemi.com

N. American Technical Support: 800-282-9855 Toll Free
USA/Canada
Europe, Middle East and Africa Technical Support:
Phone: 421 33 790 2910
Japan Customer Focus Center
Phone: 81-3-5817-1050

ON Semiconductor Website: www.onsemi.com
Order Literature: <http://www.onsemi.com/orderlit>
For additional information, please contact your local
Sales Representative

Looking for pricing, stock, or lifecycle information?

Click below to explore more details on WIN SOURCE:

- ⊖ [View FSQ0370RLA on WIN SOURCE](#)
- ⊖ [Fairchild/ON Semiconductor Information](#)

Optimize Your Supply Chain with WIN SOURCE Solutions

- ✓ Global Sourcing Solution
- ✓ Obsolete Management
- ✓ Cost Control Management
- ✓ Shortage Management
- ✓ Alternative Solution
- ✓ Excess Inventory Management