



**THE DATASHEET OF
SN75LVDS31DR**



SN75LVDS31, SN75LVDS9638 HIGH-SPEED DIFFERENTIAL LINE DRIVERS

SLLS359C – JUNE 1999 – REVISED JUNE 2001

- Meets or Exceeds the Requirements of ANSI TIA/EIA-644 Standard
- Low-Voltage Differential Signaling With Typical Output Voltage of 350 mV and a 100-Ω Load
- Signaling Rates up to 155 Mbps
- Operates From a Single 3.3-V Supply
- Driver at High Impedance When Disabled or With $V_{CC} = 0$
- Low-Voltage TTL (LVTTTL) Logic Input Levels
- Characterized For Operation From 0°C to 70°C

description

The SN75LVDS31 and SN75LVDS9638 are differential line drivers that implement the electrical characteristics of low-voltage differential signaling (LVDS). This signaling technique lowers the output voltage levels of 5-V differential standard levels (such as TIA/EIA-422B) to reduce the power, increase the switching speeds, and allow operation with a 3.3-V supply rail. Any of the four current-mode drivers will deliver a minimum differential output voltage magnitude of 247 mV into a 100-Ω load when enabled.

The intended application of these devices and signaling technique is for point-to-point baseband data transmission over controlled impedance media of approximately 100 Ω. The transmission media may be printed-circuit board traces, backplanes, or cables. The ultimate rate and distance of data transfer is dependent upon the attenuation characteristics of the media and the noise coupling to the environment.

The SN75LVDS31 and SN75LVDS9638 are characterized for operation from 0°C to 70°C.

SN75LVDS31D (Marked as 75LVDS31)
SN75LVDS31PW (Marked as DS31)
(TOP VIEW)

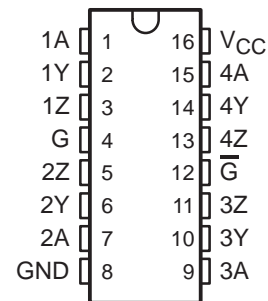

SN75LVDS9638D (Marked as DF638 or 7L9638)
SN75LVDS9638DGK (Marked as AXK)
(TOP VIEW)

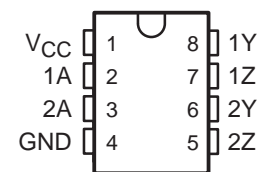

Please be aware that an important notice concerning availability, standard warranty, and use in critical applications of Texas Instruments semiconductor products and disclaimers thereto appears at the end of this data sheet.

PRODUCTION DATA information is current as of publication date. Products conform to specifications per the terms of Texas Instruments standard warranty. Production processing does not necessarily include testing of all parameters.

 **TEXAS
INSTRUMENTS**

POST OFFICE BOX 655303 • DALLAS, TEXAS 75265

Copyright © 2001, Texas Instruments Incorporated

Function Tables

SN75LVDS31

INPUT A	ENABLES		OUTPUTS	
	G	\bar{G}	Y	Z
H	H	X	H	L
L	H	X	L	H
H	X	L	H	L
L	X	L	L	H
X	L	H	Z	Z
Open	H	X	L	H
Open	X	L	L	H

H = high level, L = low level, X = irrelevant, Z = high impedance (off)

SN75LVDS9638

INPUT A	OUTPUTS	
	Y	Z
H	H	L
L	L	H
OPEN	L	H

H = high level, L = low level

equivalent input and output schematic diagrams

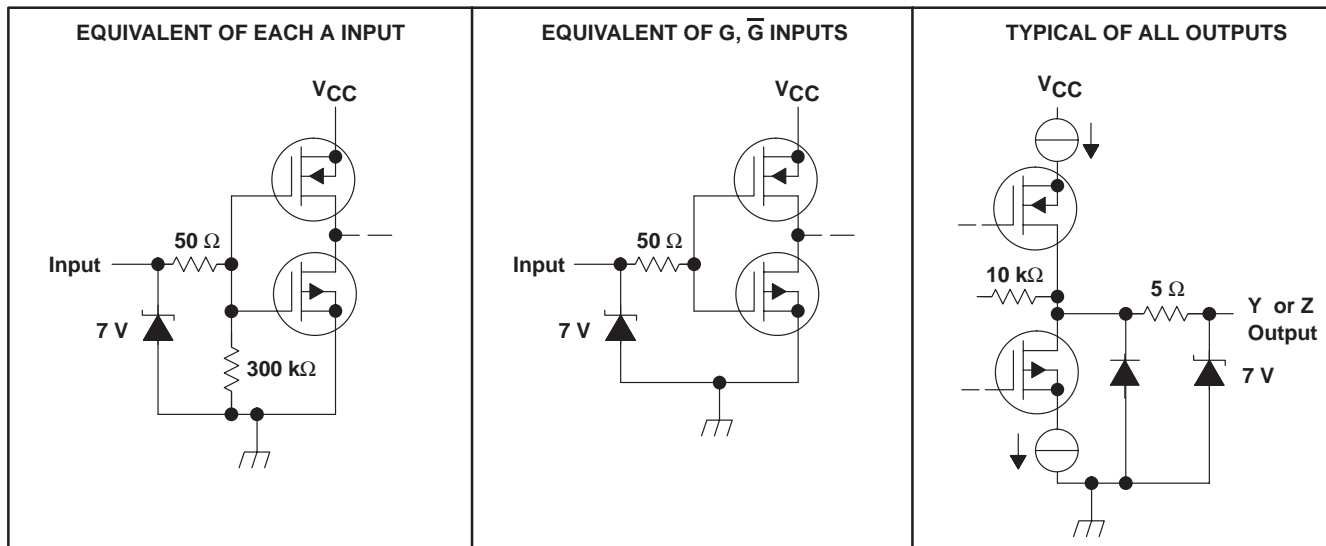

SN75LVDS31, SN75LVDS9638 HIGH-SPEED DIFFERENTIAL LINE DRIVERS

SLLS359C – JUNE 1999 – REVISED JUNE 2001

absolute maximum ratings over operating free-air temperature range (unless otherwise noted)†

Supply voltage range, V_{CC} (see Note 1)	-0.5 V to 4 V
Input voltage range: Inputs	-0.5 V to $V_{CC} + 0.5$ V
Y or Z	-0.5 V to 4 V
Continuous total power dissipation	See Dissipation Rating Table
Storage temperature range, T_{stg}	-65°C to 150°C
Lead temperature 1,6 mm (1/16 inch) from case for 10 seconds	260°C

† Stresses beyond those listed under “absolute maximum ratings” may cause permanent damage to the device. These are stress ratings only, and functional operation of the device at these or any other conditions beyond those indicated under “recommended operating conditions” is not implied. Exposure to absolute-maximum-rated conditions for extended periods may affect device reliability.

NOTE 1: All voltages, except differential I/O bus voltages, are with respect to the network ground terminal.

DISSIPATION RATING TABLE

PACKAGE	$T_A \leq 25^\circ\text{C}$ POWER RATING	DERATING FACTOR‡ ABOVE $T_A = 25^\circ\text{C}$	$T_A = 70^\circ\text{C}$ POWER RATING
D (8)	725 mW	5.8 mW/°C	464 mW
D (16)	950 mW	7.6 mW/°C	608 mW
PW	774 mW	6.2 mW/°C	496 mW
DGK	425 mW	3.4 mW/°C	272 mW

‡ This is the inverse of the junction-to-ambient thermal resistance when board-mounted and with no air flow.

recommended operating conditions

	MIN	NOM	MAX	UNIT
Supply voltage, V_{CC}	3	3.3	3.6	V
High-level input voltage, V_{IH}	2			V
Low-level input voltage, V_{IL}			0.8	V
Operating free-air temperature, T_A	0		70	°C



SN75LVDS31, SN75LVDS9638 HIGH-SPEED DIFFERENTIAL LINE DRIVERS

SLLS359C – JUNE 1999 – REVISED JUNE 2001

electrical characteristics over recommended operating conditions (unless otherwise noted)

PARAMETER		TEST CONDITIONS	SN75LVDS31, SN75LVDS9638			UNIT	
			MIN	TYP†	MAX		
V _{OD}	Differential output voltage magnitude	R _L = 100 Ω, See Figure 2	247	340	454	mV	
ΔV _{OD}	Change in differential output voltage magnitude between logic states		-50		50	mV	
ΔV _{OC(SS)}	Change in steady-state common-mode output voltage between logic states	See Figure 3	1.125	1.2	1.375	V	
V _{OC(SS)}	Steady-state common-mode output voltage		-50		50	mV	
V _{OC(PP)}	Peak-to-peak common-mode output voltage			50	150	mV	
I _{CC}	Supply current	V _I = 0.8 V or 2 V, Enabled, No load	SN75LVDS31		9	20	mA
			SN75LVDS9638		25	35	mA
		V _I = 0 or V _{CC} , Disabled	SN75LVDS31		0.25	1	mA
			SN75LVDS9638		4.7	8	mA
			SN75LVDS9638		9	13	mA
I _{IH}	High-level input current	V _{IH} = 2		4	20	μA	
I _{IL}	Low-level input current	V _{IL} = 0.8 V		0.1	10	μA	
I _{OS}	Short-circuit output current	V _{O(Y)} or V _{O(Z)} = 0		-4	-24	mA	
		V _{OD} = 0			±12	mA	
I _{OZ}	High-impedance output current	V _O = 0 or 2.4 V			±1	μA	
I _{O(OFF)}	Power-off output current	V _{CC} = 0, V _O = 2.4 V			±1	μA	
C _I	Input capacitance			3		pF	

† All typical values are at T_A = 25°C and with V_{CC} = 3.3 V.

switching characteristics over recommended operating conditions (unless otherwise noted)

PARAMETER		TEST CONDITIONS	SN75LVDS31, SN75LVDS9638			UNIT
			MIN	TYP†	MAX	
t _{pLH}	Propagation delay time, low-to-high-level output	R _L = 100 Ω, C _L = 10 pF, See Figure 2			6	ns
t _{pHL}	Propagation delay time, high-to-low-level output				6	ns
t _r	Differential output signal rise time (20% to 80%)		0.5	1.2		ns
t _f	Differential output signal fall time (80% to 20%)		0.5	1.2		ns
t _{sk(p)}	Pulse skew ((t _{pHL} - t _{pLH}))‡				0.6	ns
t _{sk(o)}	Channel-to-channel output skew§				0.6	ns
t _{sk(pp)}	Part-to-part skew¶				1	ps
t _{pZH}	Propagation delay time, high-impedance-to-high-level output	See Figure 4			25	ns
t _{pZL}	Propagation delay time, high-impedance-to-low-level output				25	ns
t _{pHZ}	Propagation delay time, high-level-to-high-impedance output				25	ns
t _{pLZ}	Propagation delay time, low-level-to-high-impedance output				25	ns

† All typical values are at T_A = 25°C and with V_{CC} = 3.3 V.

‡ t_{sk(p)} is the magnitude of the time difference between the high-to-low and low-to-high propagation delay times at an output.

§ t_{sk(o)} is the magnitude of the time difference between the outputs of a single device with all of their inputs connected together.

¶ t_{sk(pp)} is the magnitude of the difference in propagation delay times between any specified terminals of two devices when both devices operate with the same supply voltages, same temperature, and have identical packages and test circuits.



SN75LVDS31, SN75LVDS9638 HIGH-SPEED DIFFERENTIAL LINE DRIVERS

SLLS359C – JUNE 1999 – REVISED JUNE 2001

PARAMETER MEASUREMENT INFORMATION

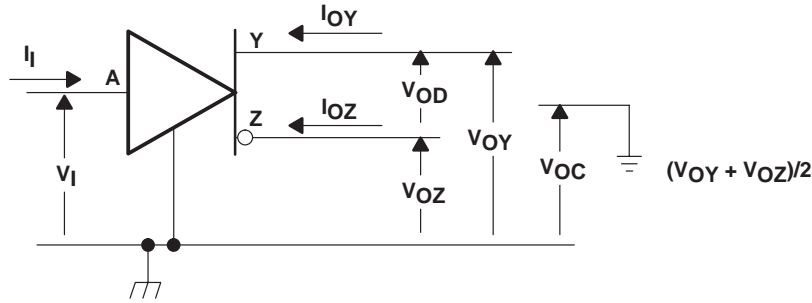
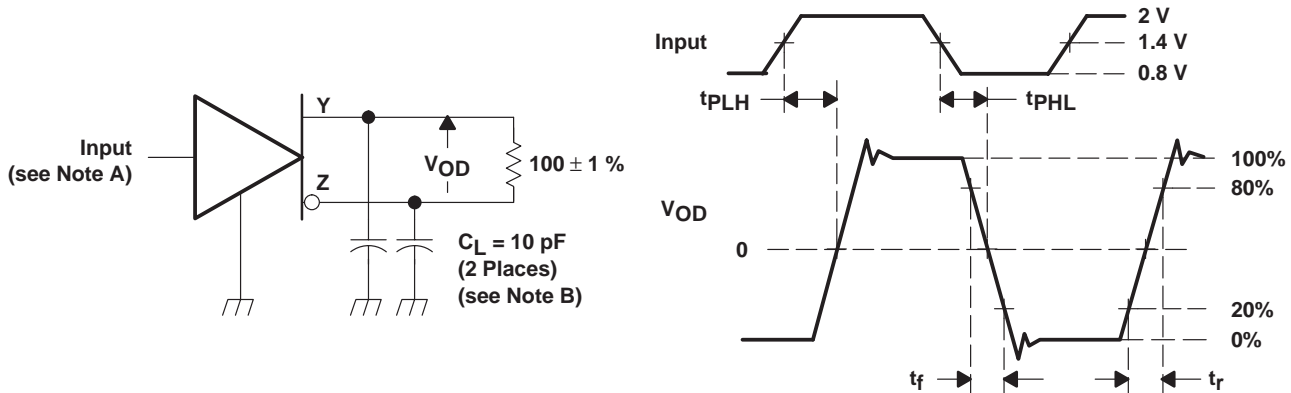
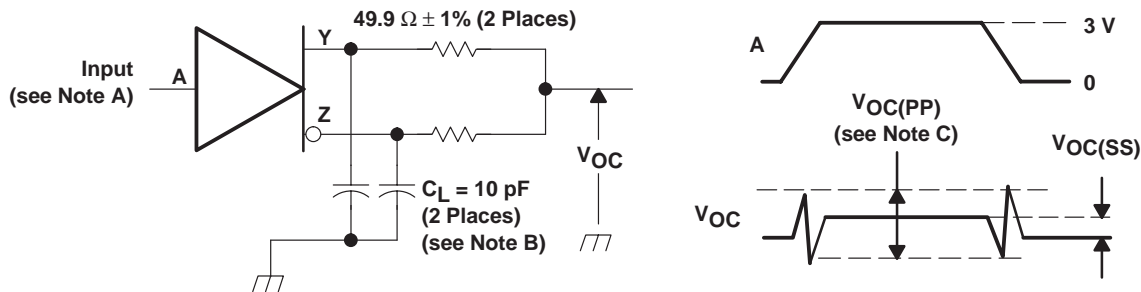

Figure 1. Voltage and Current Definitions



- NOTES: A. All input pulses are supplied by a generator having the following characteristics: t_r or $t_f \leq 1$ ns, pulse repetition rate (PRR) = 50 Mpps, pulse width = 10 ± 0.2 ns.
B. C_L includes instrumentation and fixture capacitance within 6 mm of the D.U.T.

Figure 2. Test Circuit, Timing, and Voltage Definitions for the Differential Output Signal



- NOTES: A. All input pulses are supplied by a generator having the following characteristics: t_r or $t_f \leq 1$ ns, pulse repetition rate (PRR) = 50 Mpps, pulse width = 10 ± 0.2 ns.
B. C_L includes instrumentation and fixture capacitance within 6 mm of the D.U.T.
C. The measurement of $V_{OC(PP)}$ is made on test equipment with a -3 dB bandwidth of at least 300 MHz.

Figure 3. Test Circuit and Definitions for the Driver Common-Mode Output Voltage

PARAMETER MEASUREMENT INFORMATION

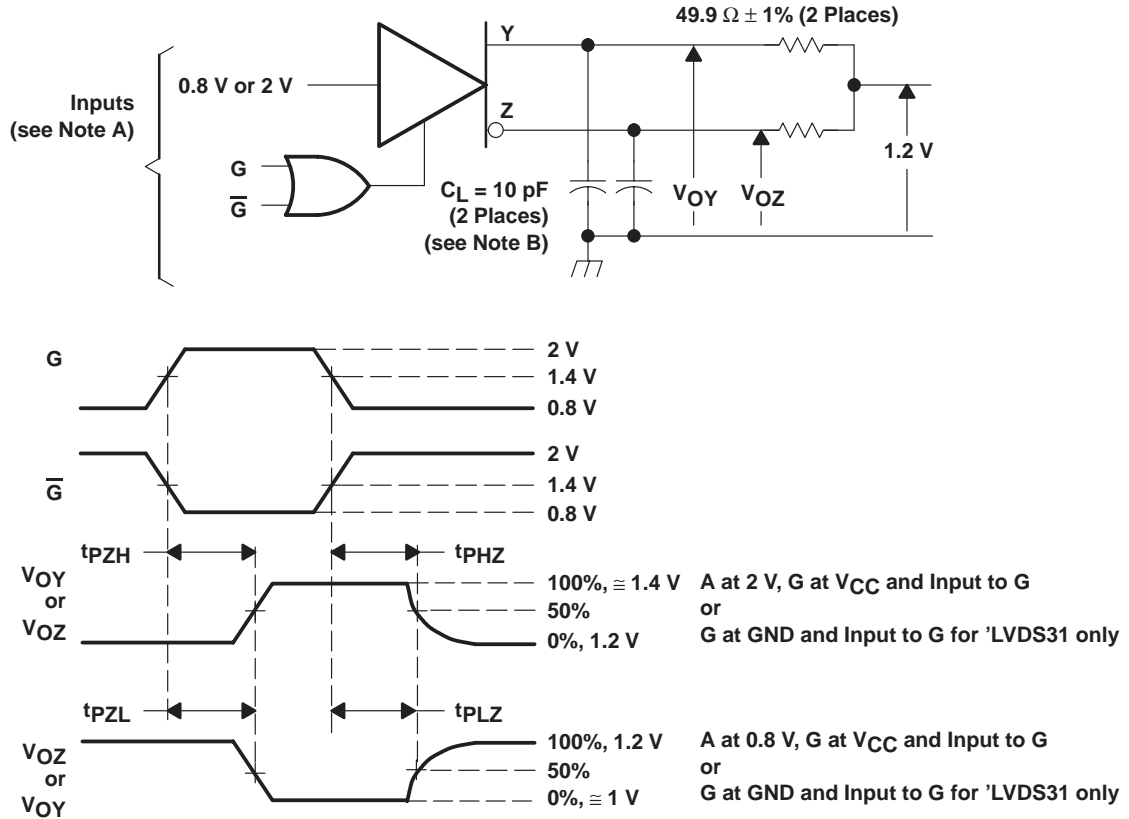

- NOTES: A. All input pulses are supplied by a generator having the following characteristics: t_r or $t_f < 1 \text{ ns}$, pulse repetition rate (PRR) = 0.5 Mpps , pulse width = $500 \pm 10 \text{ ns}$.
B. C_L includes instrumentation and fixture capacitance within 6 mm of the D.U.T.

Figure 4. Enable and Disable Time Circuit and Definitions

SN75LVDS31, SN75LVDS9638 HIGH-SPEED DIFFERENTIAL LINE DRIVERS

SLLS359C – JUNE 1999 – REVISED JUNE 2001

APPLICATIONS INFORMATION

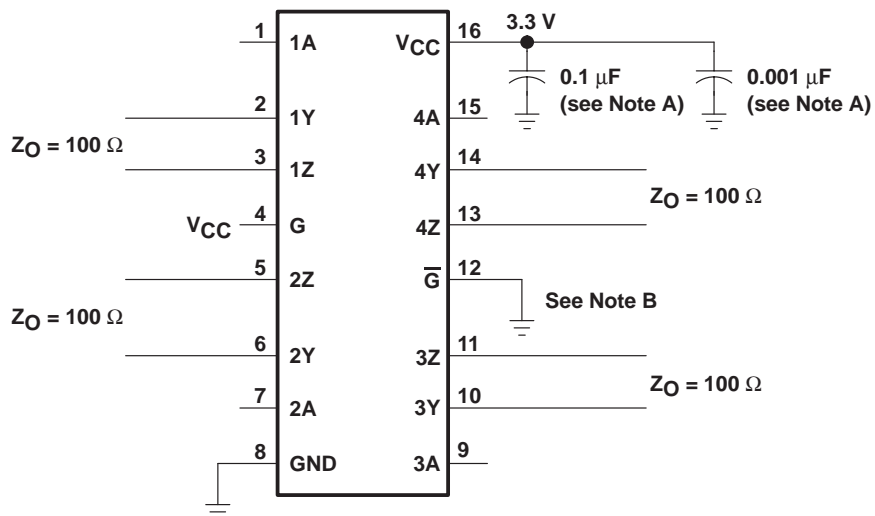

- NOTES: A. Place a 0.1 μF and a 0.001 μF Z5U ceramic, mica or polystyrene dielectric, 0805 size, chip capacitor between V_{CC} and the ground plane. The capacitors should be located as close as possible to the device terminals.
 B. Unused enable inputs should be tied to V_{CC} or GND as appropriate.

Figure 5. Typical Application Circuit Schematic

APPLICATIONS INFORMATION

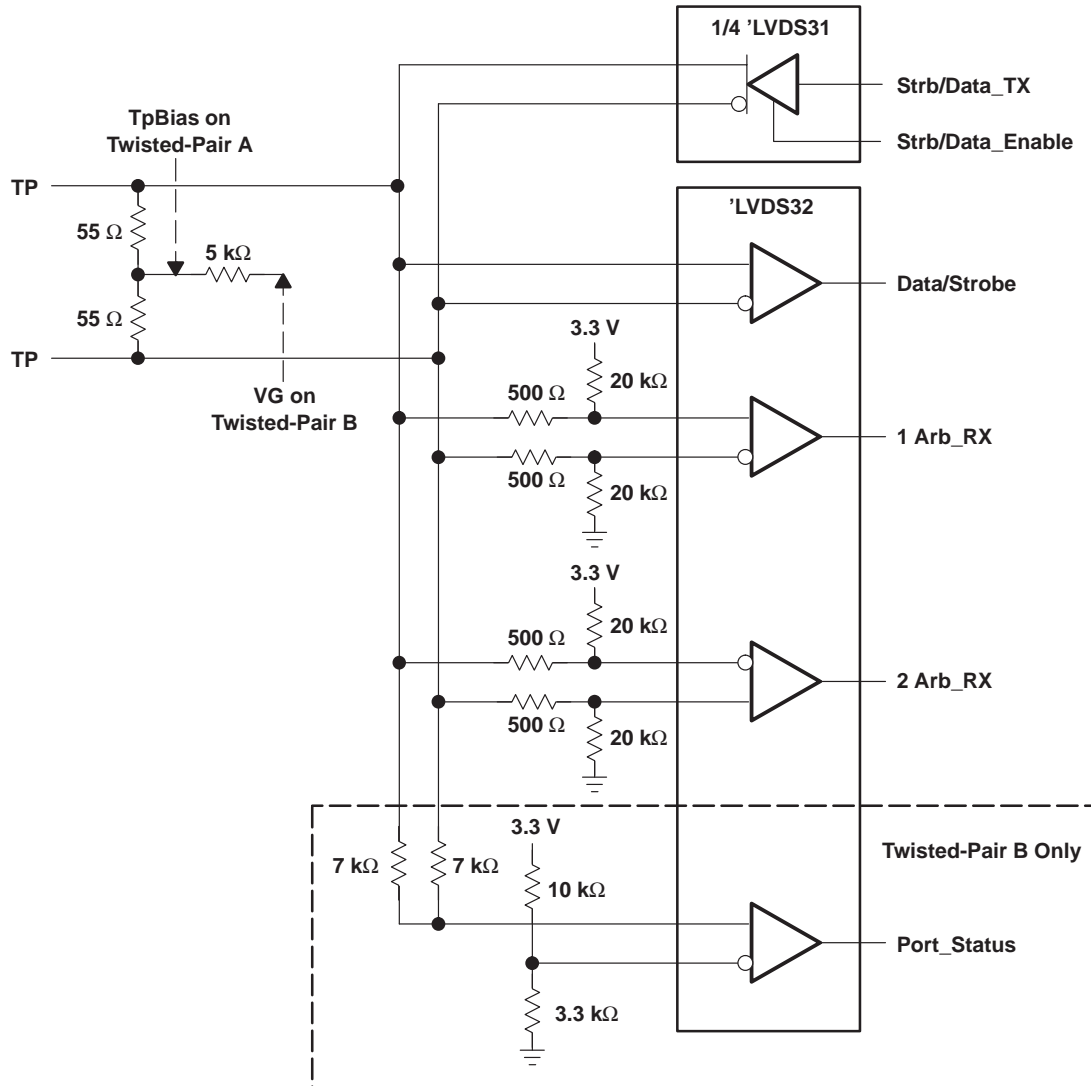

- NOTES: A. Resistors are leadless thick-film (0603) 5% tolerance.
 B. Decoupling capacitance is not shown but recommended.
 C. V_{CC} is 3 V to 3.6 V.
 D. The differential output voltage of the 'LVDS31 can exceed that specified by IEEE1394.

Figure 6. 100 Mbps IEEE1394 Transceiver

SN75LVDS31, SN75LVDS9638 HIGH-SPEED DIFFERENTIAL LINE DRIVERS

SLLS359C – JUNE 1999 – REVISED JUNE 2001

APPLICATIONS INFORMATION

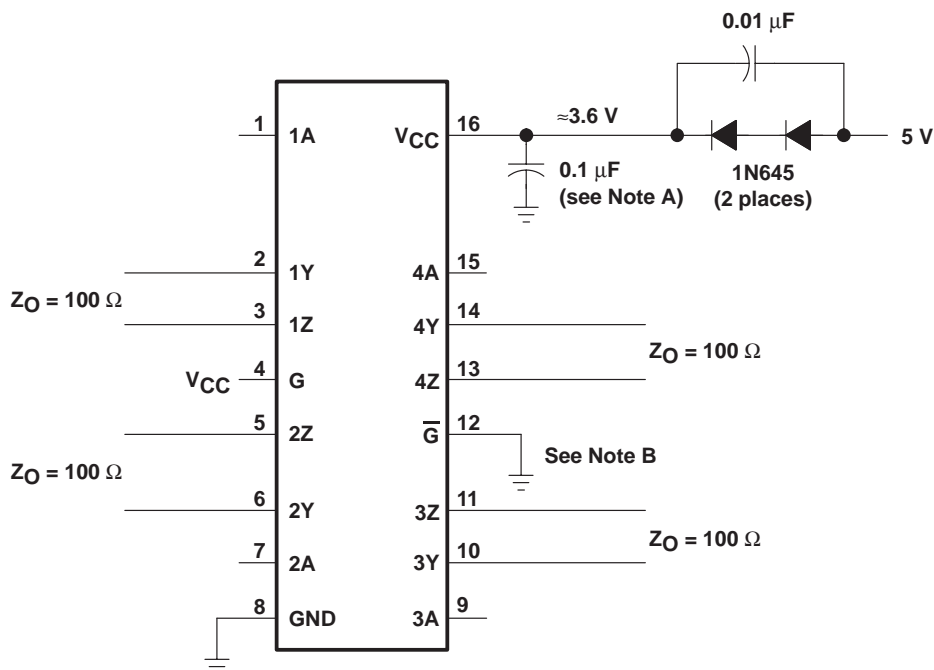

NOTE A: Place a 0.1 μF Z5U ceramic, mica or polystyrene dielectric, 0805 size, chip capacitor between V_{CC} and the ground plane. The capacitor should be located as close as possible to the device terminals.

Figure 7. Operation With a 5-V Supply

related information

IBIS modeling is available for this device. Please contact the local TI sales office or the TI Web site at www.ti.com for more information.

For more application guidelines, please see the following documents:

- *Low-Voltage Differential Signalling Design Notes* (TI literature number SLLA014)
- *Interface Circuits for TIA/EIA-644 (LVDS)* (TI literature number SLLA038)
- *Reducing EMI With LVDS* (TI literature number SLLA030)
- *Slew Rate Control of LVDS Circuits* (TI literature number SLLA034)
- *Using an LVDS Receiver With RS-422 Data* (TI literature number SLLA031)
- *Evaluating the LVDS EVM* (TI literature number SLLA033)

MECHANICAL INFORMATION

D (R-PDSO-G**)

PLASTIC SMALL-OUTLINE PACKAGE

14 PIN SHOWN

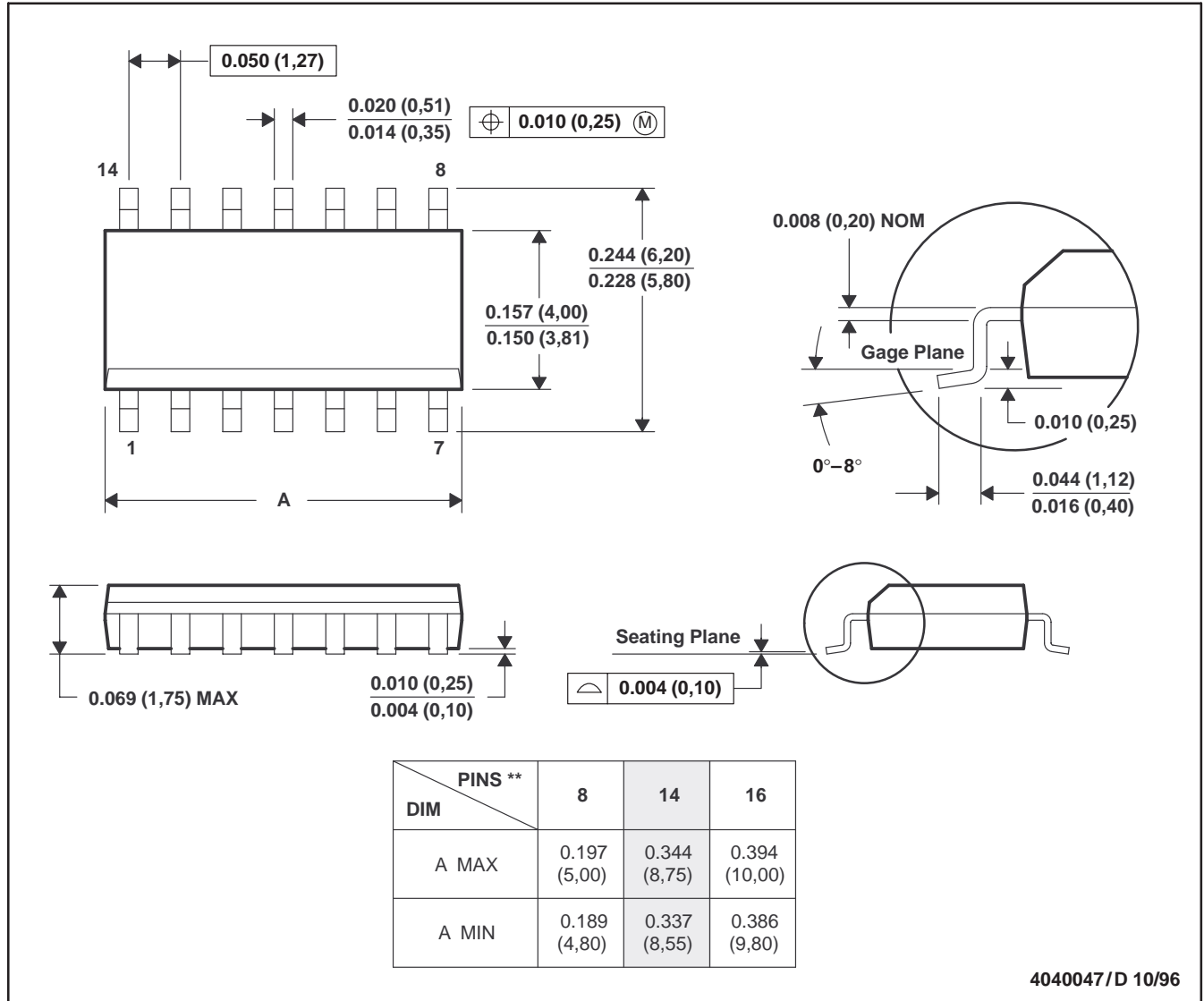

- NOTES: A. All linear dimensions are in inches (millimeters).
 B. This drawing is subject to change without notice.
 C. Body dimensions do not include mold flash or protrusion, not to exceed 0.006 (0,15).
 D. Falls within JEDEC MS-012

SN75LVDS31, SN75LVDS9638 HIGH-SPEED DIFFERENTIAL LINE DRIVERS

SLLS359C – JUNE 1999 – REVISED JUNE 2001

MECHANICAL INFORMATION

DGK (R-PDSO-G8)

PLASTIC SMALL-OUTLINE PACKAGE

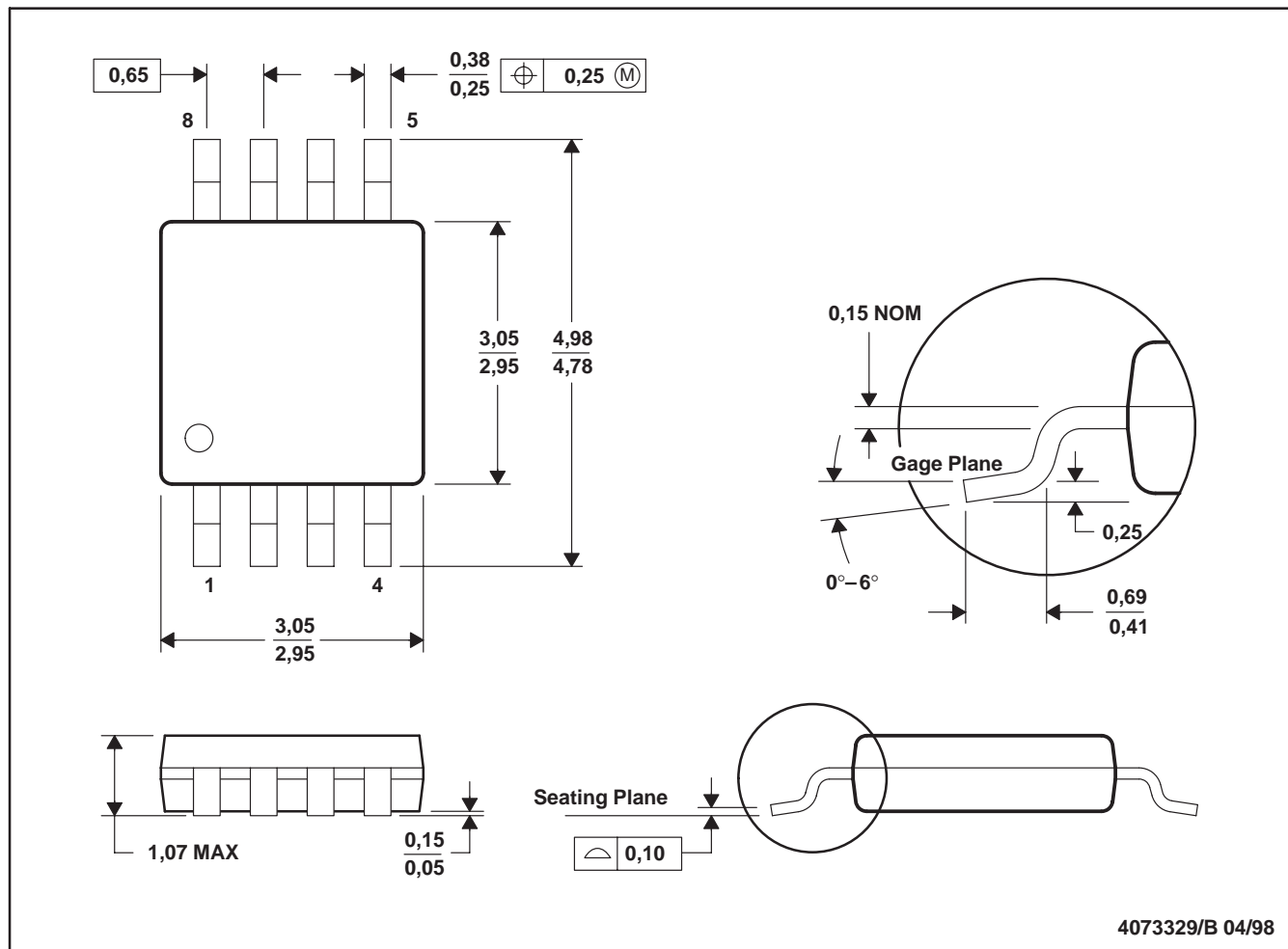

- NOTES:
- A. All linear dimensions are in millimeters.
 - B. This drawing is subject to change without notice.
 - C. Body dimensions do not include mold flash or protrusion.
 - D. Falls within JEDEC MO-187

MECHANICAL INFORMATION

PW (R-PDSO-G**)

PLASTIC SMALL-OUTLINE PACKAGE

14 PINS SHOWN

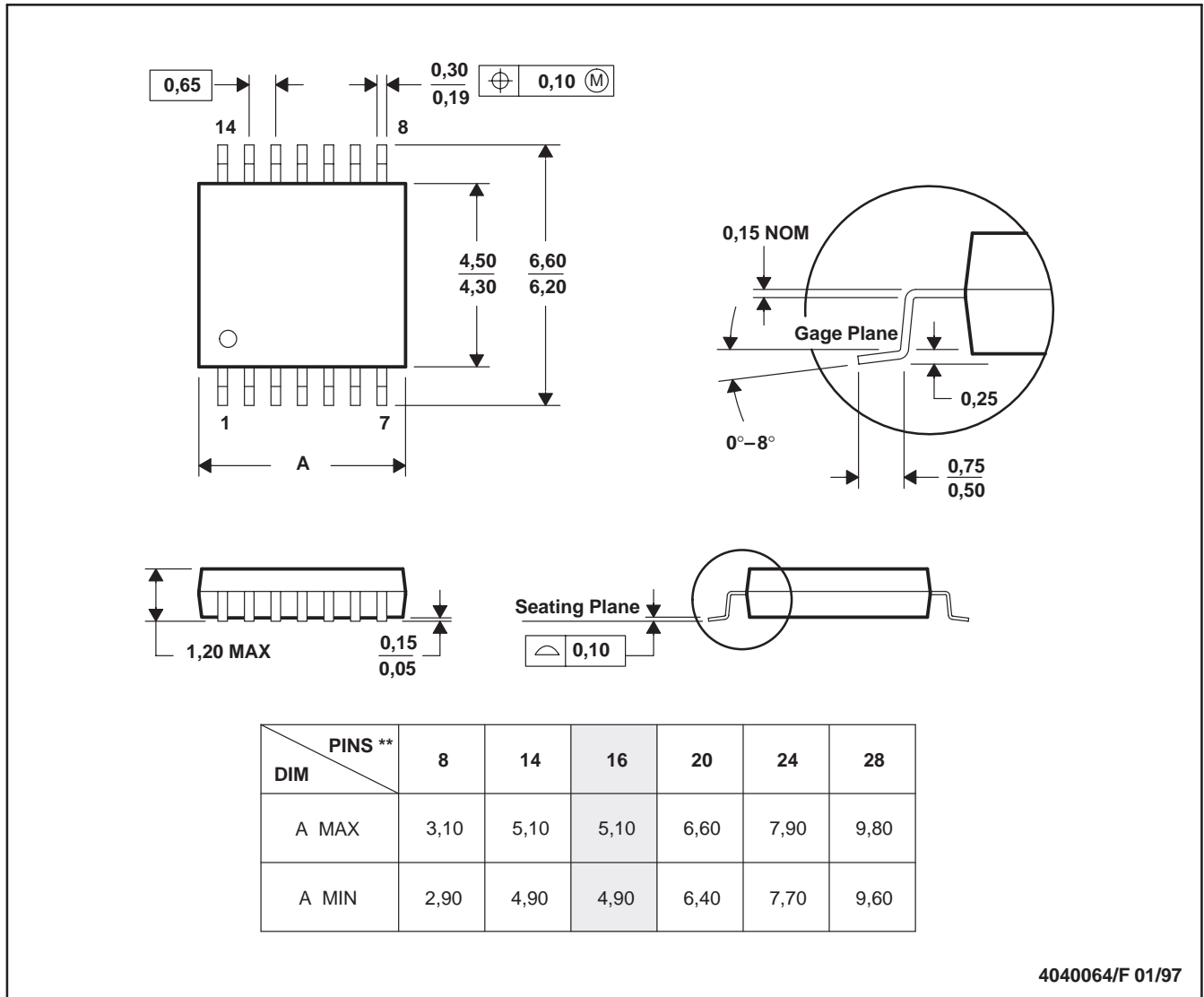

- NOTES: A. All linear dimensions are in millimeters.
 B. This drawing is subject to change without notice.
 C. Body dimensions do not include mold flash or protrusion not to exceed 0,15.
 D. Falls within JEDEC MO-153

PACKAGING INFORMATION

Orderable Device	Status ⁽¹⁾	Package Type	Package Drawing	Pins	Package Qty	Eco Plan ⁽²⁾	Lead/Ball Finish	MSL Peak Temp ⁽³⁾
SN75LVDS31D	ACTIVE	SOIC	D	16	40	Green (RoHS & no Sb/Br)	CU NIPDAU	Level-1-260C-UNLIM
SN75LVDS31DG4	ACTIVE	SOIC	D	16	40	Green (RoHS & no Sb/Br)	CU NIPDAU	Level-1-260C-UNLIM
SN75LVDS31DR	ACTIVE	SOIC	D	16	2500	Green (RoHS & no Sb/Br)	CU NIPDAU	Level-1-260C-UNLIM
SN75LVDS31DRG4	ACTIVE	SOIC	D	16	2500	Green (RoHS & no Sb/Br)	CU NIPDAU	Level-1-260C-UNLIM
SN75LVDS31PW	ACTIVE	TSSOP	PW	16	90	Green (RoHS & no Sb/Br)	CU NIPDAU	Level-1-260C-UNLIM
SN75LVDS31PWG4	ACTIVE	TSSOP	PW	16	90	Green (RoHS & no Sb/Br)	CU NIPDAU	Level-1-260C-UNLIM
SN75LVDS9638D	ACTIVE	SOIC	D	8	75	Green (RoHS & no Sb/Br)	CU NIPDAU	Level-1-260C-UNLIM
SN75LVDS9638DG4	ACTIVE	SOIC	D	8	75	Green (RoHS & no Sb/Br)	CU NIPDAU	Level-1-260C-UNLIM
SN75LVDS9638DGK	ACTIVE	MSOP	DGK	8	80	Green (RoHS & no Sb/Br)	CU NIPDAU	Level-1-260C-UNLIM
SN75LVDS9638DGK4	ACTIVE	MSOP	DGK	8	80	Green (RoHS & no Sb/Br)	CU NIPDAU	Level-1-260C-UNLIM

⁽¹⁾ The marketing status values are defined as follows:

ACTIVE: Product device recommended for new designs.

LIFEBUY: TI has announced that the device will be discontinued, and a lifetime-buy period is in effect.

NRND: Not recommended for new designs. Device is in production to support existing customers, but TI does not recommend using this part in a new design.

PREVIEW: Device has been announced but is not in production. Samples may or may not be available.

OBSOLETE: TI has discontinued the production of the device.

⁽²⁾ Eco Plan - The planned eco-friendly classification: Pb-Free (RoHS), Pb-Free (RoHS Exempt), or Green (RoHS & no Sb/Br) - please check <http://www.ti.com/productcontent> for the latest availability information and additional product content details.

TBD: The Pb-Free/Green conversion plan has not been defined.

Pb-Free (RoHS): TI's terms "Lead-Free" or "Pb-Free" mean semiconductor products that are compatible with the current RoHS requirements for all 6 substances, including the requirement that lead not exceed 0.1% by weight in homogeneous materials. Where designed to be soldered at high temperatures, TI Pb-Free products are suitable for use in specified lead-free processes.

Pb-Free (RoHS Exempt): This component has a RoHS exemption for either 1) lead-based flip-chip solder bumps used between the die and package, or 2) lead-based die adhesive used between the die and leadframe. The component is otherwise considered Pb-Free (RoHS compatible) as defined above.

Green (RoHS & no Sb/Br): TI defines "Green" to mean Pb-Free (RoHS compatible), and free of Bromine (Br) and Antimony (Sb) based flame retardants (Br or Sb do not exceed 0.1% by weight in homogeneous material)

⁽³⁾ MSL, Peak Temp. -- The Moisture Sensitivity Level rating according to the JEDEC industry standard classifications, and peak solder temperature.

Important Information and Disclaimer: The information provided on this page represents TI's knowledge and belief as of the date that it is provided. TI bases its knowledge and belief on information provided by third parties, and makes no representation or warranty as to the accuracy of such information. Efforts are underway to better integrate information from third parties. TI has taken and continues to take reasonable steps to provide representative and accurate information but may not have conducted destructive testing or chemical analysis on incoming materials and chemicals. TI and TI suppliers consider certain information to be proprietary, and thus CAS numbers and other limited information may not be available for release.

In no event shall TI's liability arising out of such information exceed the total purchase price of the TI part(s) at issue in this document sold by TI to Customer on an annual basis.

OTHER QUALIFIED VERSIONS OF SN75LVDS31 :

- Military: [SN55LVDS31](#)

NOTE: Qualified Version Definitions:

- Military - QML certified for Military and Defense Applications

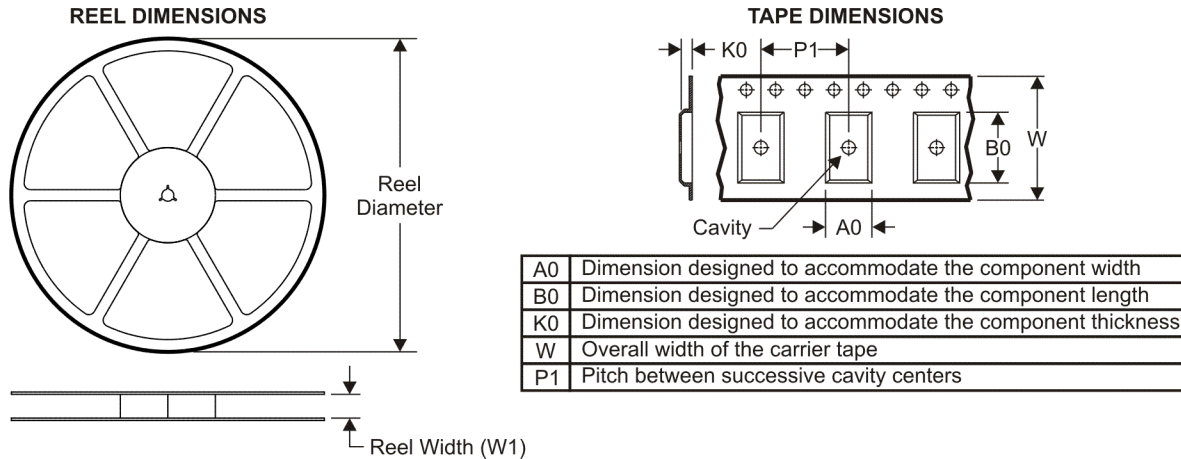
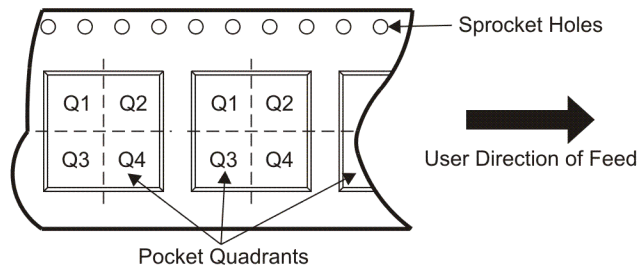
TAPE AND REEL INFORMATION

QUADRANT ASSIGNMENTS FOR PIN 1 ORIENTATION IN TAPE

*All dimensions are nominal

Device	Package Type	Package Drawing	Pins	SPQ	Reel Diameter (mm)	Reel Width W1 (mm)	A0 (mm)	B0 (mm)	K0 (mm)	P1 (mm)	W (mm)	Pin1 Quadrant
SN75LVDS31DR	SOIC	D	16	2500	330.0	16.4	6.5	10.3	2.1	8.0	16.0	Q1

TAPE AND REEL BOX DIMENSIONS



*All dimensions are nominal

Device	Package Type	Package Drawing	Pins	SPQ	Length (mm)	Width (mm)	Height (mm)
SN75LVDS31DR	SOIC	D	16	2500	333.2	345.9	28.6

IMPORTANT NOTICE

Texas Instruments Incorporated and its subsidiaries (TI) reserve the right to make corrections, modifications, enhancements, improvements, and other changes to its products and services at any time and to discontinue any product or service without notice. Customers should obtain the latest relevant information before placing orders and should verify that such information is current and complete. All products are sold subject to TI's terms and conditions of sale supplied at the time of order acknowledgment.

TI warrants performance of its hardware products to the specifications applicable at the time of sale in accordance with TI's standard warranty. Testing and other quality control techniques are used to the extent TI deems necessary to support this warranty. Except where mandated by government requirements, testing of all parameters of each product is not necessarily performed.

TI assumes no liability for applications assistance or customer product design. Customers are responsible for their products and applications using TI components. To minimize the risks associated with customer products and applications, customers should provide adequate design and operating safeguards.

TI does not warrant or represent that any license, either express or implied, is granted under any TI patent right, copyright, mask work right, or other TI intellectual property right relating to any combination, machine, or process in which TI products or services are used. Information published by TI regarding third-party products or services does not constitute a license from TI to use such products or services or a warranty or endorsement thereof. Use of such information may require a license from a third party under the patents or other intellectual property of the third party, or a license from TI under the patents or other intellectual property of TI.

Reproduction of TI information in TI data books or data sheets is permissible only if reproduction is without alteration and is accompanied by all associated warranties, conditions, limitations, and notices. Reproduction of this information with alteration is an unfair and deceptive business practice. TI is not responsible or liable for such altered documentation. Information of third parties may be subject to additional restrictions.

Resale of TI products or services with statements different from or beyond the parameters stated by TI for that product or service voids all express and any implied warranties for the associated TI product or service and is an unfair and deceptive business practice. TI is not responsible or liable for any such statements.

TI products are not authorized for use in safety-critical applications (such as life support) where a failure of the TI product would reasonably be expected to cause severe personal injury or death, unless officers of the parties have executed an agreement specifically governing such use. Buyers represent that they have all necessary expertise in the safety and regulatory ramifications of their applications, and acknowledge and agree that they are solely responsible for all legal, regulatory and safety-related requirements concerning their products and any use of TI products in such safety-critical applications, notwithstanding any applications-related information or support that may be provided by TI. Further, Buyers must fully indemnify TI and its representatives against any damages arising out of the use of TI products in such safety-critical applications.

TI products are neither designed nor intended for use in military/aerospace applications or environments unless the TI products are specifically designated by TI as military-grade or "enhanced plastic." Only products designated by TI as military-grade meet military specifications. Buyers acknowledge and agree that any such use of TI products which TI has not designated as military-grade is solely at the Buyer's risk, and that they are solely responsible for compliance with all legal and regulatory requirements in connection with such use.

TI products are neither designed nor intended for use in automotive applications or environments unless the specific TI products are designated by TI as compliant with ISO/TS 16949 requirements. Buyers acknowledge and agree that, if they use any non-designated products in automotive applications, TI will not be responsible for any failure to meet such requirements.

Following are URLs where you can obtain information on other Texas Instruments products and application solutions:

Products

Amplifiers	amplifier.ti.com
Data Converters	dataconverter.ti.com
DLP® Products	www.dlp.com
DSP	dsp.ti.com
Clocks and Timers	www.ti.com/clocks
Interface	interface.ti.com
Logic	logic.ti.com
Power Mgmt	power.ti.com
Microcontrollers	microcontroller.ti.com
RFID	www.ti-rfid.com
RF/IF and ZigBee® Solutions	www.ti.com/lprf

Applications

Audio	www.ti.com/audio
Automotive	www.ti.com/automotive
Broadband	www.ti.com/broadband
Digital Control	www.ti.com/digitalcontrol
Medical	www.ti.com/medical
Military	www.ti.com/military
Optical Networking	www.ti.com/opticalnetwork
Security	www.ti.com/security
Telephony	www.ti.com/telephony
Video & Imaging	www.ti.com/video
Wireless	www.ti.com/wireless

Mailing Address: Texas Instruments, Post Office Box 655303, Dallas, Texas 75265
Copyright © 2009, Texas Instruments Incorporated

Looking for pricing, stock, or lifecycle information?

Click below to explore more details on WIN SOURCE:

 [View SN75LVDS31DR on WIN SOURCE](#)

 [Texas Instruments](#) Information

Optimize Your Supply Chain with WIN SOURCE Solutions

-  Global Sourcing Solution
-  Obsolete Management
-  Cost Control Management
-  Shortage Management
-  Alternative Solution
-  Excess Inventory Management