

IFX91041

1.8A DC/DC Step-Down Voltage Regulator
5.0V, 3.3V or Adjustable Output Voltage

IFX91041EJV50
IFX91041EJV33
IFX91041EJV

Data Sheet

Rev. 1.1, 2011-07-08

Standard Power



1 Overview

- 1.8A step down voltage regulator
- Output voltage versions: 5.0 V, 3.3 V and adjustable
- $\pm 2\%$ output voltage tolerance (+-4% for full load current range)
- Integrated power transistor
- PWM regulation with feedforward
- Input voltage range from 4.75V to 45V
- 370 kHz switching frequency
- Synchronization input
- Very low shutdown current consumption (<2uA)
- Soft-start function
- Input undervoltage lockout
- Suited for industrial applications: $T_j = -40\text{ }^\circ\text{C}$ to $+125\text{ }^\circ\text{C}$
- Green Product (RoHS compliant)

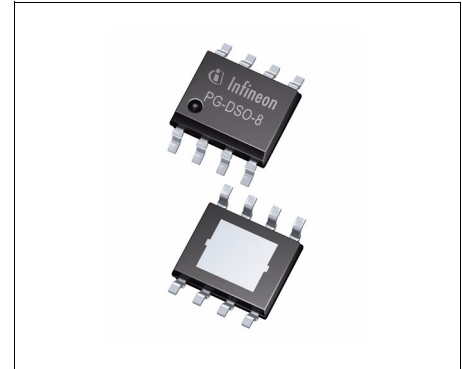

PG-DSO-8-27

For automotive and transportation applications, please refer to the Infineon TLE and TLF voltage regulator series.

Description

The IFX91041 series are monolithic integrated circuits that provide all active functions for a step-down (buck) switching voltage regulator, capable of driving up to 1.8A load current with excellent line and load regulation. These devices are suited for use in industrial applications featuring protection functions such as current limitation and overtemperature shutdown. Versions with a fixed 5.0V and 3.3V (IFX91041EJV50, IFX91041EJV33) output voltage as well as an adjustable device (IFX91041EJV) with 0.60V reference feedback voltage are available. The switching frequency of 370kHz allows to use small and inexpensive passive components. The IFX91041 features an enable function reducing the shut-down current consumption to <2uA. The voltage mode regulation scheme of this device provides a stable regulation loop maintained by small external compensation components. Besides the feedforward control path offers an excellent line transient rejection. The integrated soft-start feature limits the current peak as well as voltage overshoot at start-up.

Type	Package	Marking
IFX91041EJV50	PG-DSO-8-27	I9104150
IFX91041EJV33	PG-DSO-8-27	I9104133
IFX91041EJV	PG-DSO-8-27	I91041V

2 Block Diagram

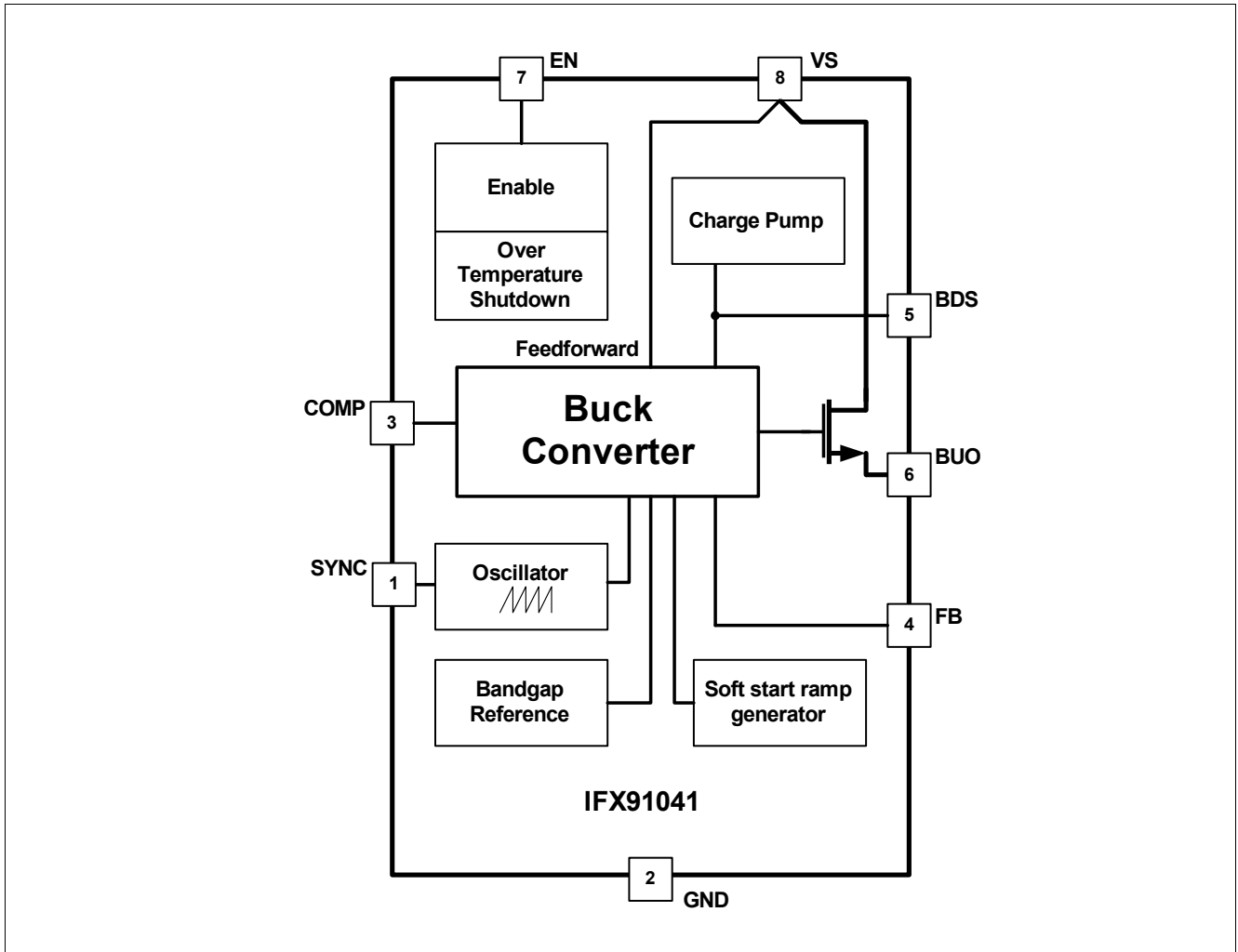

Figure 1 Block Diagram

3 Pin Configuration

3.1 Pin Assignment

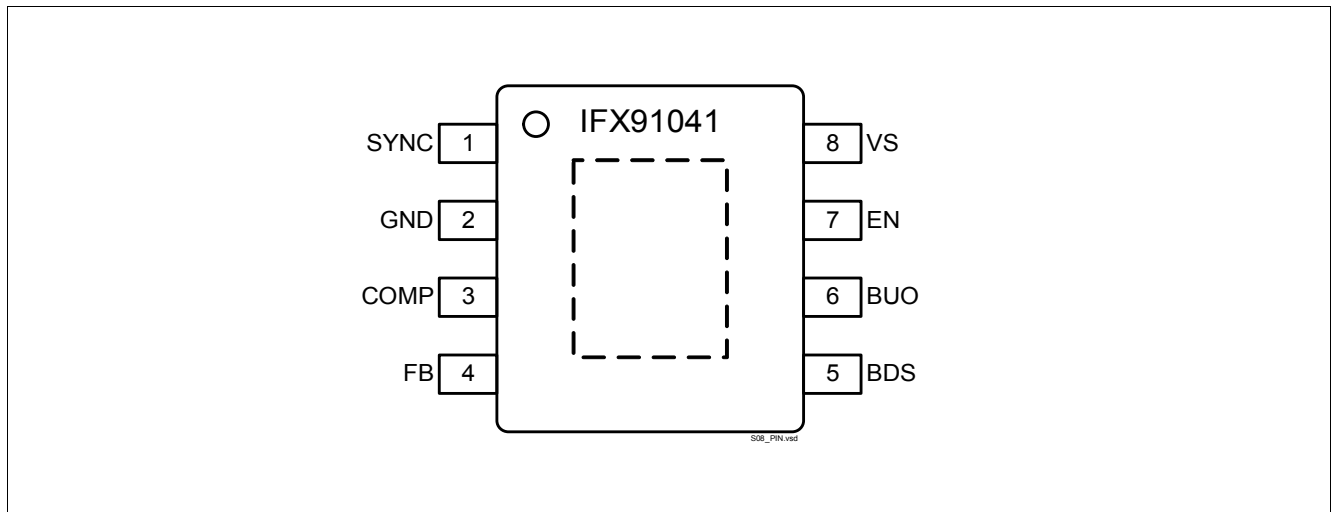

Figure 2 Pin Configuration

3.2 Pin Definitions and Functions

Pin	Symbol	Function
1	SYNC	Synchronization Input. Connect to an external clock signal in order to synchronize/adjust the switching frequency. If not used connect to GND.
2	GND	Ground.
3	COMP	Compensation Input. Frequency compensation for regulation loop stability. Connect to compensation RC-network.
4	FB	Feedback Input. For the adjustable output voltage versions (IFX91041EJV) connect via voltage divider to output capacitor. For the fixed voltage version (IFX91041EJV50, IFX91041EJV33) connect this pin directly to the output capacitor.
5	BDS	Buck Driver Supply Input. Connect the bootstrap capacitor between this pin and pin BUO.
6	BUO	Buck Switch Output. Source of the integrated power-DMOS transistor. Connect directly to the cathode of the catch diode and the buck circuit inductance.
7	EN	Enable Input. Active-high enable input with integrated pull down resistor.
8	VS	Supply Voltage Input. Connect to supply voltage source.
Exposed Pad		Connect to heatsink area and GND by low inductance wiring.

4 General Product Characteristics

4.1 Absolute Maximum Ratings

Absolute Maximum Ratings¹⁾

$T_j = -40\text{ °C}$ to $+125\text{ °C}$; all voltages with respect to ground (unless otherwise specified)

Pos.	Parameter	Symbol	Limit Values		Unit	Conditions
			Min.	Max.		
Voltages						
4.1.1	Synchronization Input	V_{SYNC}	-0.3	5.5	V	–
				6.2	V	$t < 10\text{s}^2)$
4.1.2	Compensation Input	V_{COMP}	-0.3	5.5	V	–
				6.2	V	$t < 10\text{s}^1)$
4.1.3						
4.1.4	Feedback Input	V_{FB}	-0.3	10	V	IFX91041EJV50; IFX91041EJV33
				5.5	V	IFX91041EJV
4.1.5						
4.1.6	Buck Driver Supply Input	V_{BDS}	V_{BUO} - 0.3	V_{BUO} + 5.5	V	
4.1.7	Buck Switch Output	V_{BUO}	-2.0	$V_{\text{VS}} + 0.3$	V	
4.1.8	Enable Input	V_{EN}	-40	45	V	
4.1.9	Supply Voltage Input	V_{VS}	-0.3	45	V	
Temperatures						
4.1.10	Junction Temperature	T_j	-40	150	°C	–
4.1.11	Storage Temperature	T_{stg}	-55	150	°C	–
ESD Susceptibility						
4.1.12	ESD Resistivity	V_{ESD}	-2	2	kV	HBM ³⁾

1) Not subject to production test, specified by design.

2) Exposure to those absolute maximum ratings for extended periods of time ($t > 10\text{s}$) may affect device reliability

3) ESD susceptibility HBM according to EIA/JESD 22-A 114B (1.5kΩ, 100pF).

Note: Stresses above the ones listed here may cause permanent damage to the device. Exposure to absolute maximum rating conditions for extended periods may affect device reliability.

Note: Integrated protection functions are designed to prevent IC destruction under fault conditions described in the data sheet. Fault conditions are considered as “outside” normal operating range. Protection functions are not designed for continuous repetitive operation.

4.2 Functional Range

Pos.	Parameter	Symbol	Limit Values		Unit	Conditions
			Min.	Max.		
4.2.1	Supply Voltage	V_S	4.75	45	V	–
4.2.2	Output Voltage adjust range	V_{CC}	0.60	16	V	IFX91041EJV
4.2.3	Buck inductor	L_{BU}	18	56	μH	–
4.2.4	Buck capacitor	C_{BU1}	33	120	μF	–
4.2.5	Buck capacitor ESR	ESR_{BU1}	–	0.3	Ω	– ¹⁾
4.2.6	Junction Temperature	T_j	-40	125	$^{\circ}\text{C}$	–

1) See section ““Application Information” on Page 12” for loop compensation requirements.

Note: Within the functional range the IC operates as described in the circuit description. The electrical characteristics are specified within the conditions given in the related electrical characteristics table.

4.3 Thermal Resistance

Pos.	Parameter	Symbol	Limit Values			Unit	Conditions
			Min.	Typ.	Max.		
4.3.1	Junction to Case ¹⁾	R_{thJC}	–	–	12	K/W	–
4.3.2	Junction to ambient ¹⁾	R_{thJA}	–	52	–	K/W	²⁾

1) Not subject to production test, specified by design.

2) According to Jedec JESD52-1,-5,-7 at natural convection on 2s2p FR4 PCB for 1W power dissipation. PCB 76.2x114.3x1.5mm³ with 2 inner copper layers of 70 μm thickness. Thermal via array connected to the first inner copper layer under the exposed pad.

5 Buck Regulator

5.1 Description

The gate of the power switch is driven by the external capacitor connected to pin BDS (Buck Driver Supply) using the bootstrap principle. An integrated under voltage lockout function supervising the 'bootstrap' capacitor voltage ensures that the device is always driven with a sufficient bootstrap voltage in order to prevent from extensive heat up of the power transistor. An integrated charge pump supports the gate drive in case of low input supply voltage, small differential voltage between input supply and output voltage at low current and during startup. In order to minimize emission, the charge pump is switched off if the input voltage is sufficient for supplying the bootstrap.

The soft start function generates a defined ramp of the output voltage during the first 0.5 ms (typ.) after device initialization. The device initialization is triggered either by the EN voltage level crossing the turn-on threshold, rising supply voltage (during EN=H), and also when the device restarts after thermal shutdown. The ramp starts after the BDS external capacitor is charged.

The regulation scheme uses a voltage controlled pulse width modulation with feed forward path (the feed forward operates for supply voltages from 8.0V to 36V) which provides a fast line transient reaction.

In order to maintain the output voltage regulation even under low duty cycle conditions (light load conditions down to ICC=0mA, high input voltage) a pulse skipping operation mode is implemented. Pulse skipping is also used for operation with low supply voltages, related to high duty cycles >92%

In case of a lost connection to the pin FB, an internal pull-up current prevents from a uncontrolled rise of the output voltage (version IFX91041EJV only).

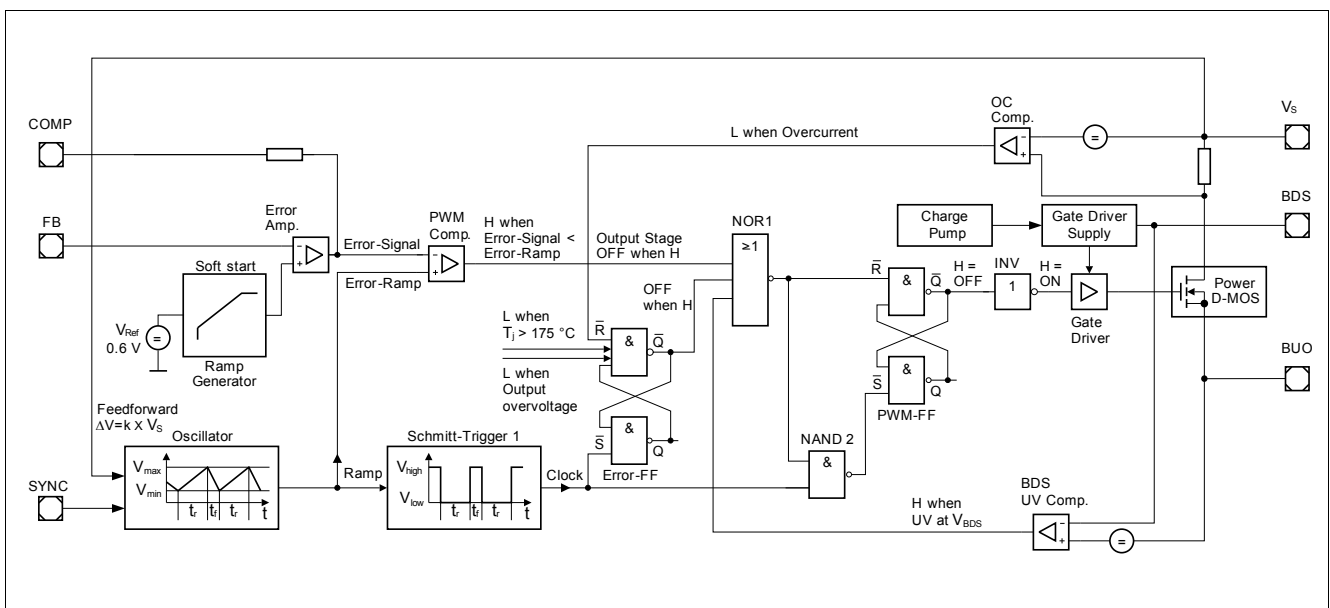

Figure 3 Block Diagram Buck Regulator

5.2 Electrical Characteristics

Electrical Characteristics: Buck Regulator

$V_S = 6.0\text{ V to }40\text{ V}$, $T_j = -40\text{ °C to }+125\text{ °C}$, all voltages with respect to ground (unless otherwise specified)

Pos.	Parameter	Symbol	Limit Values			Unit	Conditions
			Min.	Typ.	Max.		
5.2.1	Output voltage	V_{FB}	4.90	5.00	5.10	V	IFX91041EJV50; $V_{VEN} = V_S$ $0.1\text{ A} < I_{CC} < 1.0\text{ A}$
5.2.2		V_{FB}	4.80	5.00	5.20	V	IFX91041EJV50; $V_{VEN} = V_S$; $1\text{ mA} < I_{CC} < 1.8\text{ A}$
5.2.3	Output voltage	V_{FB}	3.23	3.30	3.37	V	IFX91041EJV33; $V_{VEN} = V_S$; $0.1\text{ A} < I_{CC} < 1.0\text{ A}$
5.2.4		V_{FB}	3.17	3.30	3.43	V	IFX91041EJV33; $V_{VEN} = V_S$; $1\text{ mA} < I_{CC} < 1.8\text{ A}$
5.2.5	Output voltage	V_{FB}	0.588	0.60	0.612	V	IFX91041EJV; $V_{VEN} = V_S$; FB connected to V_{CC} ; $V_S = 12\text{ V}$ $0.1\text{ A} < I_{CC} < 1.0\text{ A}$
5.2.6		V_{FB}	0.576	0.60	0.624	V	IFX91041EJV; $V_{VEN} = V_S$; FB connected to V_{CC} ; $V_S = 12\text{ V}$ $1\text{ mA} < I_{CC} < 1.8\text{ A}$
5.2.7	Minimum output load requirement	$I_{CC,MIN}$	0	–	–	mA	IFX91041EJV50 ¹⁾
5.2.8			1	–	–	mA	IFX91041EJV33 ¹⁾
5.2.9			1.5			mA	IFX91041EJV $V_{CC} \gg 3\text{ V}^{1)}$
5.2.10			5			mA	IFX91041EJV $V_{CC} \gg 1.5\text{ V}^{1)}$
5.2.11			10	–	–	mA	IFX91041EJV $V_{CC} \gg 0.6\text{ V}^{1)}$
5.2.12	FB input current	I_{FB}	-1	-0.1	0	μA	IFX91041EJV $V_{FB} = 0.6\text{ V}$
5.2.13	FB input current	I_{FB}	–	–	900	μA	IFX91041EJV50, IFX91041EJV33
5.2.14	Power stage on-resistance	R_{on}	–	–	500	m Ω	tested at 300 mA
5.2.15	Current transition rise/fall time	t_r	–	50	–	ns	$I_{CC} = 1\text{ A}^{2)}$
5.2.16	Buck peak over current limit	I_{BUOC}	2.2	–	3.6	A	–
5.2.17	Bootstrap under voltage lockout, turn-off threshold	$V_{BDS,off}$	$V_{BUO} + 3.3$	–	–	V	Bootstrap voltage decreasing
5.2.18	Charge pump current	I_{CP}	2	–	–	mA	$V_S = 12\text{ V}$; $V_{BUO} = V_{BDS} = \text{GND}$

Electrical Characteristics: Buck Regulator
 $V_S = 6.0\text{ V to }40\text{ V}$, $T_j = -40\text{ °C to }+125\text{ °C}$, all voltages with respect to ground (unless otherwise specified)

Pos.	Parameter	Symbol	Limit Values			Unit	Conditions
			Min.	Typ.	Max.		
5.2.19	Charge pump switch-off threshold	$V_{BDS} - V_{BUO}$	–	–	5	V	$(V_{BDS} - V_{BUO})$ increasing
5.2.20	Maximum duty cycle	D_{max}	–	–	100	%	³⁾
5.2.21	Soft start ramp	t_{start}	350	500	750	μs	V_{FB} rising from 5% to 95% of $V_{FB,nom}$
5.2.22	Input under voltage shutdown threshold	$V_{S,off}$	3.75	–	–	V	V_S decreasing
5.2.23	Input voltage startup threshold	$V_{S,on}$	–	–	4.75	V	V_S increasing
5.2.24	Input under voltage shutdown hysteresis	$V_{S,hyst}$	150	–	–	mV	–

1) Not subject to production test, application related parameter

2) Not subject to production test; specified by design.

 3) Consider "[Chapter 4.2, Functional Range](#)"

6 Module Enable and Thermal Shutdown

6.1 Description

With the enable pin the device can be set in off-state reducing the current consumption to less than 2µA.

The enable function features an integrated pull down resistor which ensures that the IC is shut down and the power switch is off in case the pin EN is left open.

The integrated thermal shutdown function turns the power switch off in case of overtemperature. The typ. junction shutdown temperature is 175°C, with a min. of 160°C. After cooling down the IC will automatically restart operation. The thermal shutdown is an integrated protection function designed to prevent IC destruction when operating under fault conditions. It should not be used for normal operation.

6.2 Electrical Characteristics Module Enable, Bias and Thermal Shutdown

Electrical Characteristics: Enable, Bias and Thermal Shutdown

$V_S = 6.0\text{ V to }40\text{ V}$, $T_j = -40\text{ °C to }+125\text{ °C}$, all voltages with respect to ground (unless otherwise specified)

Pos.	Parameter	Symbol	Limit Values			Unit	Conditions
			Min.	Typ.	Max.		
6.2.1	Current Consumption, shut down mode	$I_{q,OFF}$	–	0.1	2	µA	$V_{EN} = 0.8\text{V}$; $T_j < 105\text{°C}$; $V_S = 16\text{V}$
6.2.2	Current Consumption, active mode	$I_{q,ON}$	–	–	7	mA	$V_{EN} = 5.0\text{V}$; $I_{CC} = 0\text{mA}$; $V_S = 16\text{V}$ FB connected to V_{OUT}
6.2.3	Current Consumption, active mode	$I_{q,ON}$	–	–	10	mA	$V_{EN} = 5.0\text{V}$; $I_{CC} = 1.8\text{A}$; $V_S = 16\text{V}$ FB connected to V_{OUT} ¹⁾
6.2.4	Enable high signal valid	$V_{EN,lo}$	3.0	–	–	V	–
6.2.5	Enable low signal valid	$V_{EN,hi}$	–	–	0.8	V	–
6.2.6	Enable hysteresis	$V_{EN,HY}$	50	200	400	mV	¹⁾
6.2.7	Enable high input current	$I_{EN,hi}$	–	–	30	µA	$V_{EN} = 16\text{V}$
6.2.8	Enable low input current	$I_{EN,lo}$	–	0.1	1	µA	$V_{EN} = 0.5\text{V}$
6.2.9	Over temperature shutdown	$T_{j,sd}$	160	175	190	°C	¹⁾
6.2.10	Over temperature shutdown hysteresis	T_{j,sd_hyst}	–	15	–	K	¹⁾

1) Specified by design. Not subject to production test.

7 Module Oscillator

7.1 Description

The oscillator turns on the power switch with a constant frequency while the buck regulating circuit turns the power transistor off in every cycle with an appropriate time gap depending on the output and input voltage.

The internal sawtooth signal used for the PWM generation has an amplitude proportional to the input supply voltage (feedforward).

The turn-on frequency can optionally be set externally via the 'SYNC' pin using a TTL compatible input signal. In this case the synchronization of the PWM-on signal refers to the falling edge of the 'SYNC'-pin input signal. In case the synchronization to an external clock signal is not needed the 'SYNC' pin should be connected to GND.

Leaving pin SYNC open or short-circuiting it to GND leads to normal operation with the internal switching frequency.

7.2 Electrical Characteristics Module Oscillator

Electrical Characteristics: Buck Regulator

$V_S = 6.0\text{ V to }40\text{ V}$, $T_j = -40\text{ °C to }+125\text{ °C}$, all voltages with respect to ground (unless otherwise specified)

Pos.	Parameter	Symbol	Limit Values			Unit	Conditions
			Min.	Typ.	Max.		
7.2.1	Oscillator frequency	f_{osc}	330	370	420	kHz	$V_{SYNC} = 0V$
7.2.2	Synchronization capture range	f_{sync}	200		530	kHz	
7.2.3	SYNC signal high level valid	$V_{SYNC,hi}$	2.9			V	¹⁾
7.2.4	SYNC signal low level valid	$V_{SYNC,lo}$			0.8	V	¹⁾
7.2.5	SYNC input internal pull-down	R_{SYNC}	0.60	1.0	1.4	MΩ	$V_{SYNC} = 5V$

1) Synchronization of PWM-on signal to falling edge.

8 Application Information

Note: The following information is given as a hint for the implementation of the device only and shall not be regarded as a description or warranty of a certain functionality, condition or quality of the device.

8.1 Frequency Compensation

The stability of the output voltage can be achieved with a simple RC connected between pin COMP and GND. The standard configuration using the switching frequency of the internal oscillator is a ceramic capacitor $C_{COMP} = 22\text{nF}$ and $R_{COMP} = 22\text{k}\Omega$. By slight modifications to the compensation network the stability can be optimized for different application needs, such as varying switching frequency (using the synchronizing function), different types of buck capacitor (ceramic or tantalum) etc.

The compensation network is essential for control loop stability. Leaving pin COMP open might lead to instable operation.

8.2 Compensating a tantalum buck capacitor C_{BU1}

The TLE control loop is optimized for ceramic buck capacitors C_{BU} . In order to maintain stability also for tantalum capacitors with ESR up to $300\text{m}\Omega$, an additional compensation capacitance C_{COMP2} at pin COMP to GND is required. It's value calculates:

$$C_{COMP2} = C_{BU} * ESR(C_{BU}) / R_{COMP} ,$$

whereas C_{COMP2} needs to stay below 5nF .

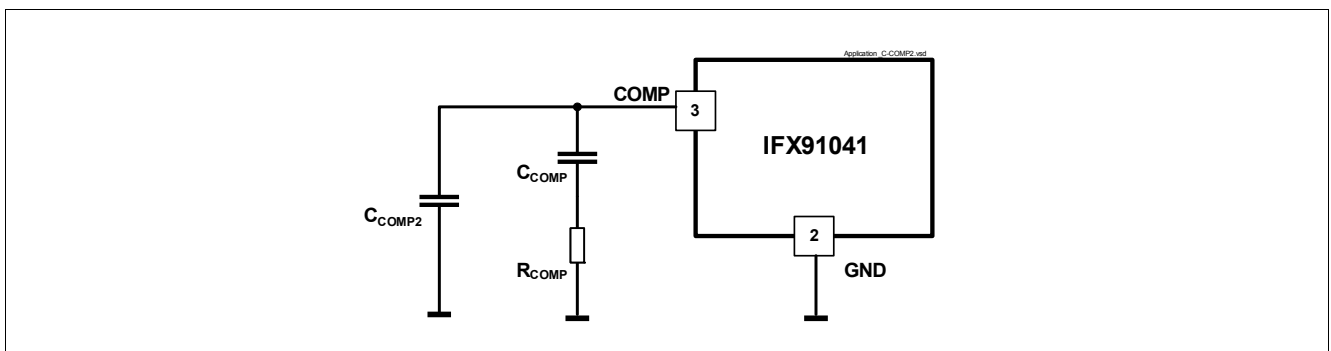

Figure 4 High-ESR buck capacitor compensation

8.3 Catch Diode

In order to minimize losses and for fast recovery, a schottky catch diode is required. Disconnecting the catch diode during operation might lead to destruction of the IC.

8.4 IFX91041EJV50, IFX91041EJV33 with fixed Output Voltage

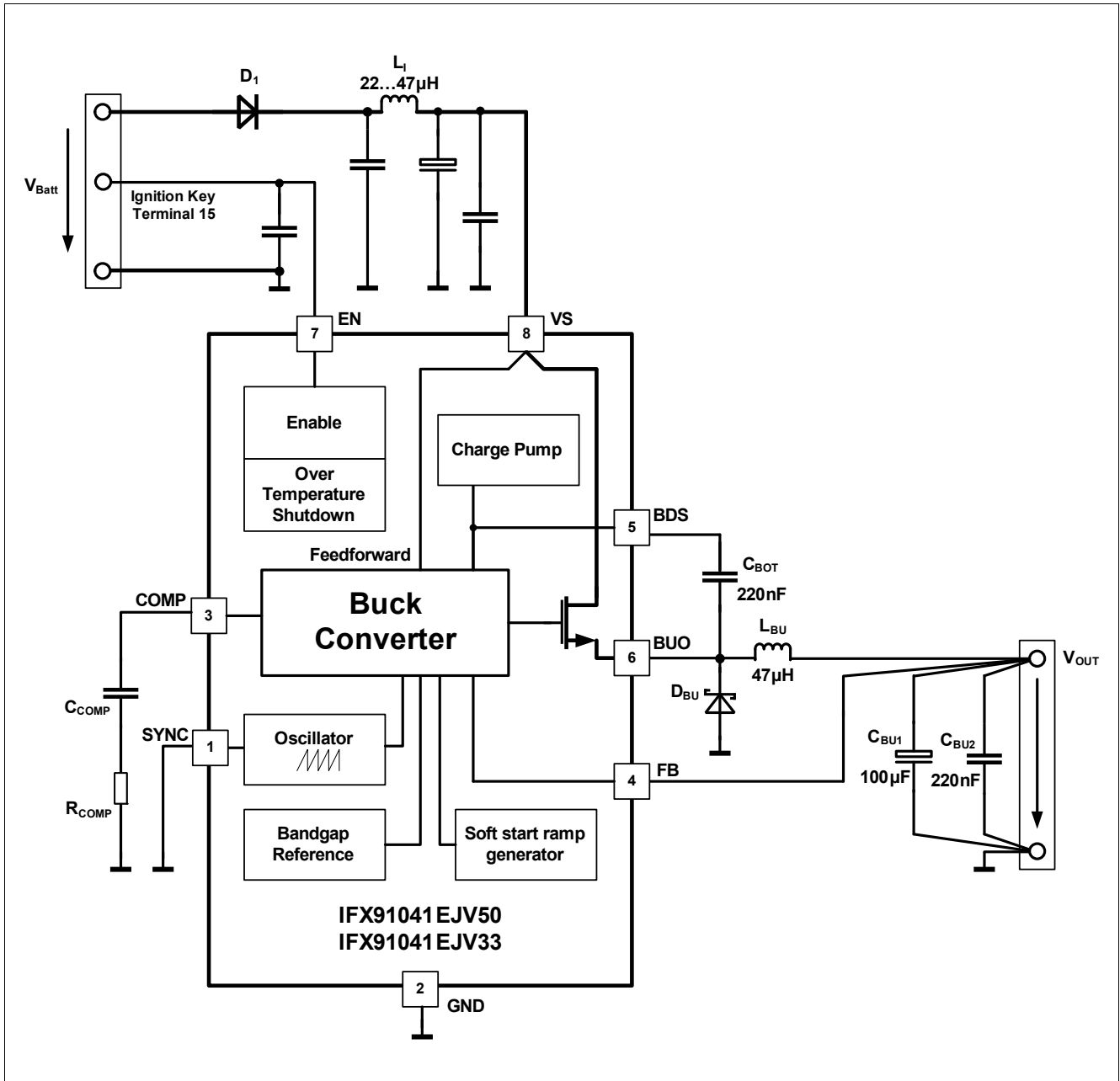

Figure 5 Application Diagram IFX91041EJV50 or IFX91041EJV33

Note: This is a very simplified example of an application circuit. The function must be verified in the real application

8.5 Adjustable Output Voltage Device

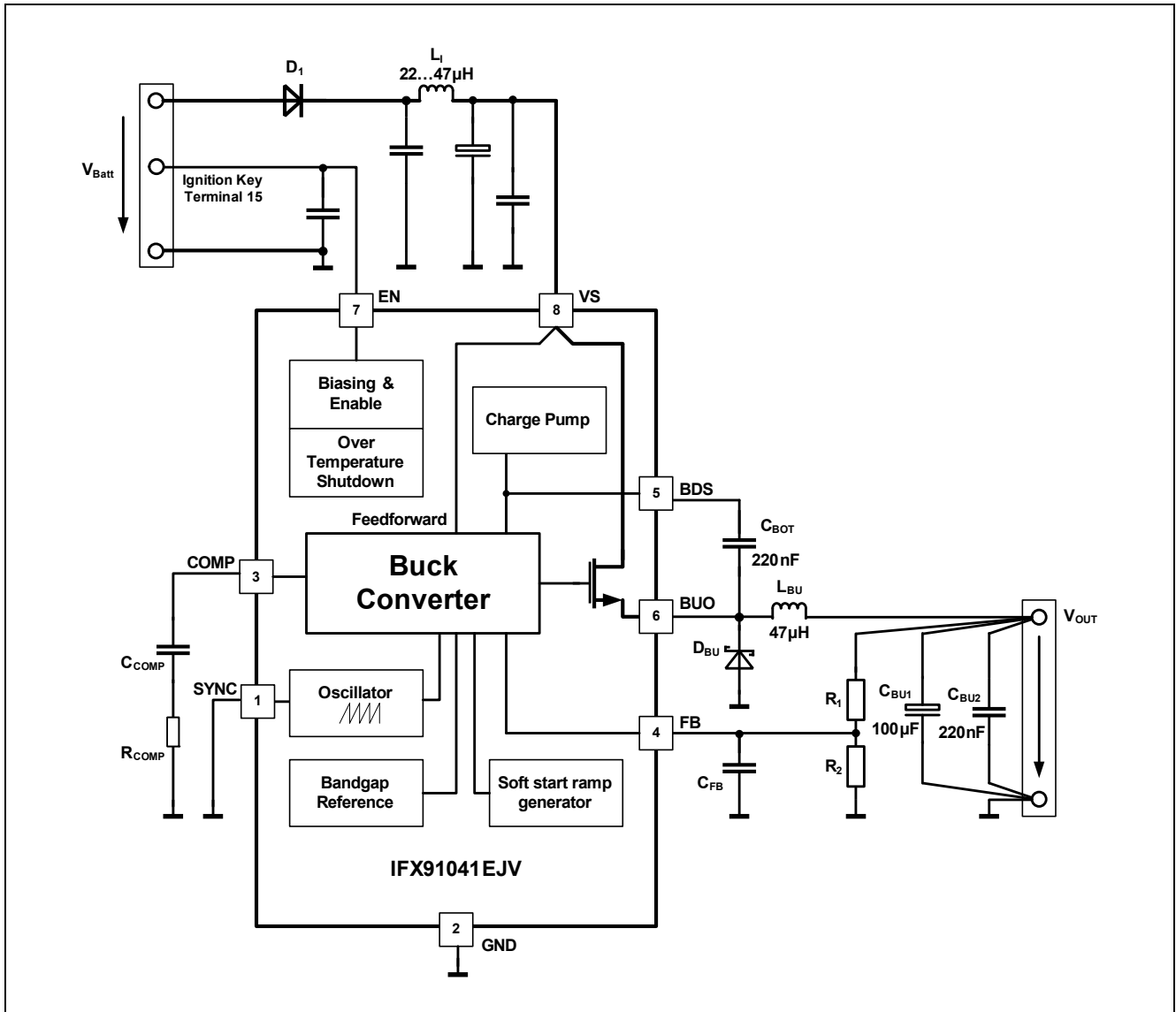

Figure 6 Application Diagram IFX91041EJV

Note: This is a very simplified example of an application circuit. The function must be verified in the real application

The output voltage of the IFX91041EJV can be programmed by a voltage divider connected to the feedback pin FB. The divider cross current should be 300 μ A at minimum, therefore the maximum R_2 calculates:

$$R_2 \leq V_{FB} / I_{R2} \rightarrow R_2 \leq 0.6V / 300 \mu A = 2 \text{ k}\Omega$$

For the desired output voltage level V_{CC} , R_1 calculates then (neglecting the small FB input current):

$$R_1 = R_2 \left(\frac{V_{CC}}{V_{FB}} - 1 \right).$$

Add a 0.5 nF capacitor close to FB pin.

9 Package Outlines

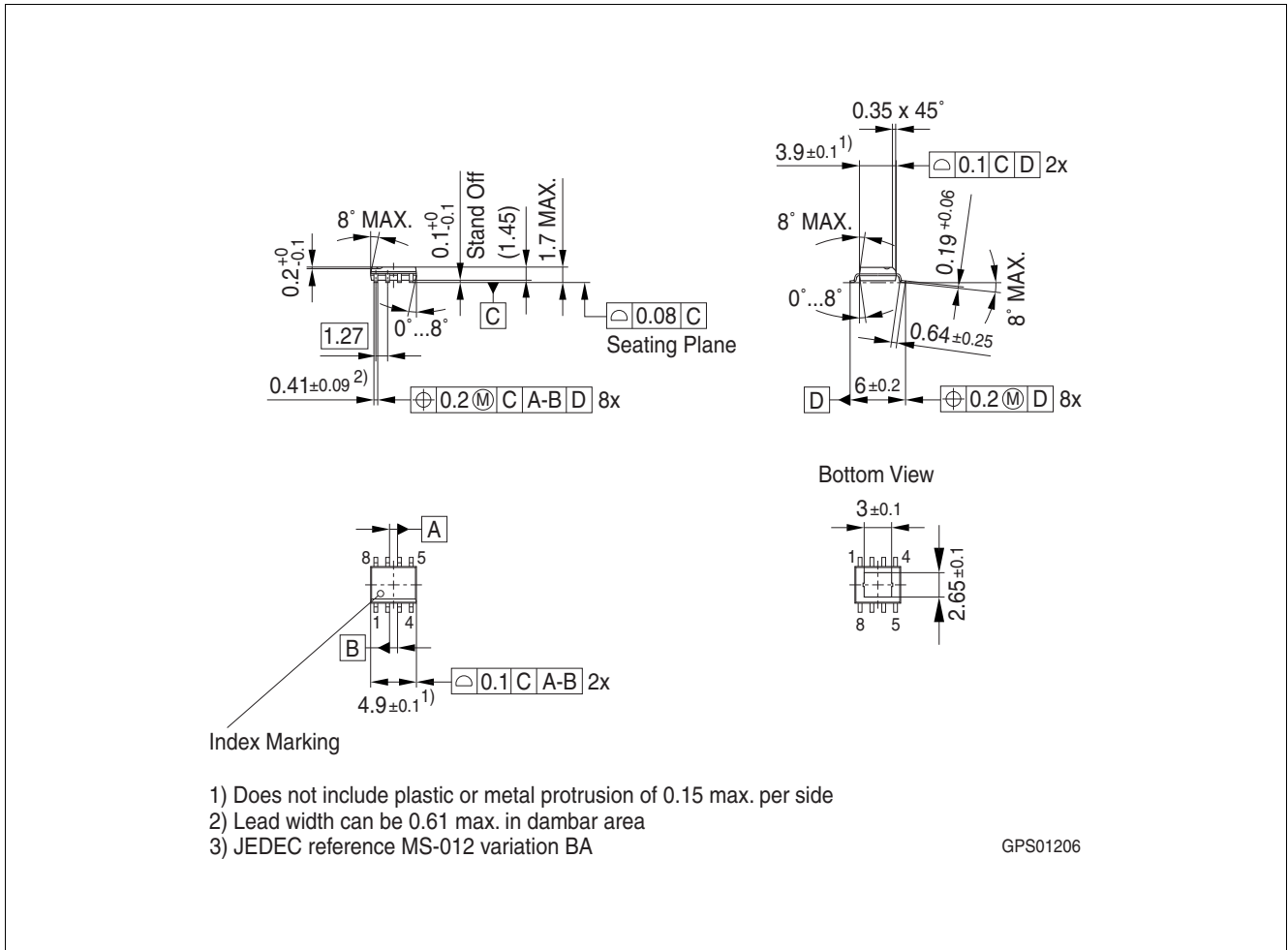

Figure 7 Outline PG-DSO-8-27

Green Product (RoHS compliant)

To meet the world-wide customer requirements for environmentally friendly products and to be compliant with government regulations the device is available as a green product. Green products are RoHS-Compliant (i.e. Pb-free finish on leads and suitable for Pb-free soldering according to IPC/JEDEC J-STD-020).

For further package information, please visit our website:
<http://www.infineon.com/packages>.

Dimensions in mm

10 Revision History

Rev.1.1	2011-07-08	Adjustment of Junction Temperature Range in (4.2.6) “Functional Range” on Page 6 to the conditions used in the “Electrical Characteristics” on Page 8 ff (-40°C to 125°C)
Rev.1.02	2010-02-23	Editorial change
Rev.1.01	2009-10-19	Overview page: Inserted reference statement to TLE/TLF series.
Rev.1.0	2009-05-04	Final data sheet

Edition 2011-07-08

**Published by
Infineon Technologies AG
81726 Munich, Germany**

**© 2011 Infineon Technologies AG
All Rights Reserved.**

Legal Disclaimer

The information given in this document shall in no event be regarded as a guarantee of conditions or characteristics. With respect to any examples or hints given herein, any typical values stated herein and/or any information regarding the application of the device, Infineon Technologies hereby disclaims any and all warranties and liabilities of any kind, including without limitation, warranties of non-infringement of intellectual property rights of any third party.

Information

For further information on technology, delivery terms and conditions and prices, please contact the nearest Infineon Technologies Office (www.infineon.com).

Warnings

Due to technical requirements, components may contain dangerous substances. For information on the types in question, please contact the nearest Infineon Technologies Office.

Infineon Technologies components may be used in life-support devices or systems only with the express written approval of Infineon Technologies, if a failure of such components can reasonably be expected to cause the failure of that life-support device or system or to affect the safety or effectiveness of that device or system. Life support devices or systems are intended to be implanted in the human body or to support and/or maintain and sustain and/or protect human life. If they fail, it is reasonable to assume that the health of the user or other persons may be endangered.

Looking for pricing, stock, or lifecycle information?

Click below to explore more details on WIN SOURCE:

-  [View IFX91041EJV on WIN SOURCE](#)
-  [Infineon Technologies Information](#)

Optimize Your Supply Chain with WIN SOURCE Solutions

-  Global Sourcing Solution
-  Obsolete Management
-  Cost Control Management
-  Shortage Management
-  Alternative Solution
-  Excess Inventory Management