



**THE DATASHEET OF  
LP2981-28DBVRG4**



## 100-mA ULTRA-LOW DROPOUT REGULATOR WITH SHUTDOWN

### FEATURES

- Output Tolerance of
  - 0.75% (A Grade)
  - 1.25% (Standard Grade)
- Ultra-Low Dropout, Typically
  - 200 mV at Full Load of 100 mA
  - 7 mV at 1 mA
- Wide  $V_{IN}$  Range...16 V Max
- Low  $I_Q$ ...600  $\mu$ A Typ at Full Load of 100 mA
- Shutdown Current...0.01  $\mu$ A Typ
- Fast Transient Response to Line and Load
- Overcurrent and Thermal Protection
- High Peak Current Capability
- ESD Protection Exceeds JESD 22
  - 2000-V Human-Body Model (A114-A)
  - 200-V Machine Model (A115-A)

### PORTABLE APPLICATIONS

- Mobile Phones
- Laptops
- Personal Digital Assistants (PDAs)
- Digital Cameras and Camcorders
- CD and MP3 Players

DBV (SOT-23) PACKAGE  
(TOP VIEW)

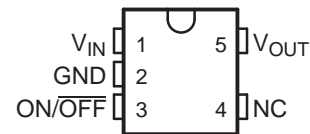

NC – No connect; must be left open

### DESCRIPTION/ORDERING INFORMATION

The LP2981 family of fixed-output, low-dropout regulators offers exceptional, cost-effective performance for both portable and nonportable applications. Available in fixed voltages of 2.8 V, 3 V, 3.3 V, and 5 V, the family has an output tolerance of 0.75% for the A-grade devices (1.25% for the standard grade) and is capable of delivering 100-mA continuous load current. Standard regulator features, such as overcurrent and overtemperature protection, are included.

The LP2981 has features that make the regulator an ideal candidate for a variety of portable applications:

- Low dropout: A PNP pass element allows a typical dropout of 200 mV at 100-mA load current and 7 mV at 1-mA load.
- Low quiescent current: The use of a vertical PNP process allows for quiescent currents that are considerably lower than those associated with traditional lateral PNP regulators.
- Shutdown: A shutdown feature is available, allowing the regulator to consume only 0.01  $\mu$ A when the ON/OFF pin is pulled low.
- Small packaging: For the most space-constrained needs, the regulator is available in the SOT-23 package.



Please be aware that an important notice concerning availability, standard warranty, and use in critical applications of Texas Instruments semiconductor products and disclaimers thereto appears at the end of this data sheet.

**ORDERING INFORMATION<sup>(1)</sup>**

T <sub>J</sub>	PART GRADE	V <sub>OUT</sub> (NOM)	PACKAGE <sup>(2)</sup>	ORDERABLE PART NUMBER	TOP-SIDE MARKING <sup>(3)</sup>	
–40°C to 125°C	A grade: 0.75% tolerance	2.8 V	SOT-23-5 – DBV	Reel of 3000	LP2981A-28DBVR	LP6_
				Reel of 250	LP2981A-28DBVT	
		2.9 V		Reel of 3000	LP2981A-29DBVR	LRB_
				Reel of 250	LP2981A-29DBVT	
		3 V		Reel of 3000	LP2981A-30DBVR	LP8_
				Reel of 250	LP2981A-30DBVT	
	3.3 V	Reel of 3000		LP2981A-33DBVR	LPC_	
		Reel of 250		LP2981A-33DBVT		
	5 V	Reel of 3000		LP2981A-50DBVR	LPE_	
		Reel of 250		LP2981A-50DBVT		
	Standard grade: 1.25% tolerance	2.8 V		Reel of 3000	LP2981-28DBVR	LP5_
				Reel of 250	LP2981-28DBVT	
		2.9 V	Reel of 3000	LP2981-29DBVR	LP3_	
			Reel of 250	LP2981-29DBVT		
		3 V	Reel of 3000	LP2981-30DBVR	LP7_	
			Reel of 250	LP2981-30DBVT		
	3.3 V	Reel of 3000	LP2981-33DBVR	LPB_		
		Reel of 250	LP2981-33DBVT			
5 V	Reel of 3000	LP2981-50DBVR	LPD_			
	Reel of 250	LP2981-50DBVT				

- (1) For the most current package and ordering information, see the Package Option Addendum at the end of this document, or see the TI web site at [www.ti.com](http://www.ti.com).
- (2) Package drawings, thermal data, and symbolization are available at [www.ti.com/packaging](http://www.ti.com/packaging).
- (3) The actual top-side marking has one additional character that designates the wafer fab/assembly site.

FUNCTIONAL BLOCK DIAGRAM

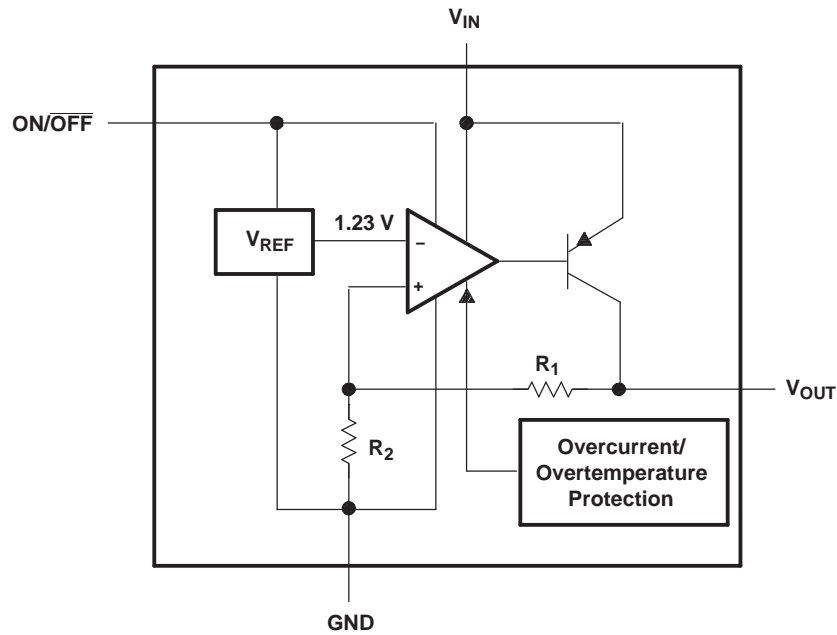

BASIC APPLICATION CIRCUIT

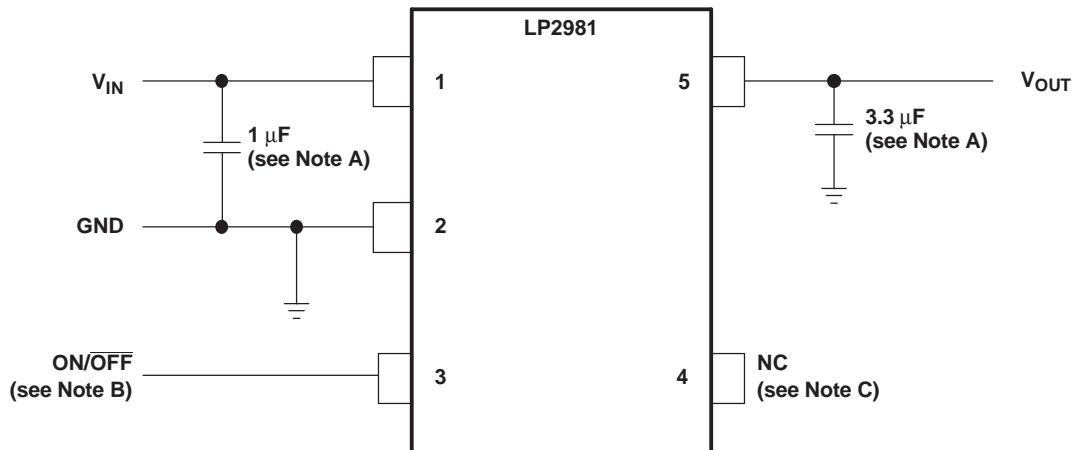

- A. Minimum  $C_{OUT}$  value for stability (can be increased without limit for improved stability and transient response)
- B.  $ON/\overline{OFF}$  must be actively terminated. Connect to  $V_{IN}$  if shutdown feature is not used.
- C. Pin 4 (NC) must be left open. Do not connect anything to this pin.

Figure 1.

## Absolute Maximum Ratings<sup>(1)</sup>

over virtual junction temperature range (unless otherwise noted)

		MIN	MAX	UNIT
V <sub>IN</sub>	Continuous input voltage range <sup>(2)</sup>	–0.3	16	V
V <sub>ON/OFF</sub>	ON/OFF input voltage range	–0.3	16	V
V <sub>OUT</sub>	Output voltage range <sup>(3)</sup>	–0.3	9	V
I <sub>OUT</sub>	Output current <sup>(4)</sup>	Internally limited (short-circuit protected)		
θ <sub>JA</sub>	Package thermal impedance <sup>(4)(5)</sup>		206	°C/W
T <sub>J</sub>	Operating virtual junction temperature		150	°C
T <sub>stg</sub>	Storage temperature range	–65	150	°C
ESD	Electrostatic discharge protection	Human-Body Model (HBM)	2000	V
		Machine Model (MM)	200	

- (1) Stresses beyond those listed under "absolute maximum ratings" may cause permanent damage to the device. These are stress ratings only, and functional operation of the device at these or any other conditions beyond those indicated under "recommended operating conditions" is not implied. Exposure to absolute-maximum-rated conditions for extended periods may affect device reliability.
- (2) The PNP pass transistor has a parasitic diode connected between the input and output. This diode normally is reverse biased (V<sub>IN</sub> > V<sub>OUT</sub>), but will be forward biased if the output voltage exceeds the input voltage by a diode drop (see *Application Information* for more details).
- (3) If load is returned to a negative power supply, the output must be diode clamped to GND.
- (4) Maximum power dissipation is a function of T<sub>J(max)</sub>, θ<sub>JA</sub>, and T<sub>A</sub>. The maximum allowable power dissipation at any allowable ambient temperature is P<sub>D</sub> = (T<sub>J(max)</sub> – T<sub>A</sub>)/θ<sub>JA</sub>. Operating at the absolute maximum T<sub>J</sub> of 150°C can affect reliability.
- (5) The package thermal impedance is calculated in accordance with JESD 51-7.

## Recommended Operating Conditions

		MIN	MAX	UNIT
V <sub>IN</sub>	Supply input voltage	2.2 <sup>(1)</sup>	16	V
V <sub>ON/OFF</sub>	ON/OFF input voltage	0	V <sub>IN</sub>	V
V <sub>IN</sub> – V <sub>OUT</sub>	Input-output differential	0.7	11	V
I <sub>OUT</sub>	Output current		100	mA
T <sub>J</sub>	Virtual junction temperature	–40	125	°C

- (1) Minimum V<sub>IN</sub> of 2.2 V is needed for proper biasing of LDO control circuitry.

## Electrical Characteristics

at specified free-air temperature range,  $V_{IN} = V_{OUT(NOM)} + 1\text{ V}$ ,  $V_{ON/OFF} = 2\text{ V}$ ,  $C_{IN} = 1\text{ }\mu\text{F}$ ,  $I_L = 1\text{ mA}$ ,  $C_{OUT} = 4.7\text{ }\mu\text{F}$   
(unless otherwise noted)

PARAMETER	TEST CONDITIONS	T <sub>A</sub>	LP2981A-xx			LP2981-xx			UNIT
			MIN	TYP	MAX	MIN	TYP	MAX	
$\Delta V_{OUT}$ Output voltage tolerance	$I_L = 1\text{ mA}$	25°C	-0.75		0.75	-1.25		1.25	%V <sub>NOM</sub>
	$I_L = 1\text{ mA to }100\text{ mA}$	25°C	-1		1	-2		2	
		-40°C to 125°C	-2.5		2.5	-3.5		3.5	
$\Delta V_{OUT}/\Delta V_{IN}$ Output voltage line regulation	$V_{IN} = (V_{OUT(NOM)} + 1\text{ V})$ to 16 V	25°C		0.007	0.014		0.007	0.014	%V
		-40°C to 125°C			0.032			0.032	
$V_{IN} - V_{OUT}$ Dropout voltage <sup>(1)</sup>	$I_L = 0$	25°C		1	3		1	3	mV
		-40°C to 125°C			5			5	
	$I_L = 1\text{ mA}$	25°C		7	10		7	10	
		-40°C to 125°C			15			15	
	$I_L = 25\text{ mA}$	25°C		70	100		70	100	
		-40°C to 125°C			150			150	
$I_L = 100\text{ mA}$	25°C		200	250		200	250		
	-40°C to 125°C			375			375		
$I_{GND}$ Ground pin current	$I_L = 0$	25°C		65	95		65	95	$\mu\text{A}$
		-40°C to 125°C			125			125	
	$I_L = 1\text{ mA}$	25°C		80	110		80	110	
		-40°C to 125°C			170			170	
	$I_L = 25\text{ mA}$	25°C		200	300		200	300	
		-40°C to 125°C			550			550	
	$I_L = 100\text{ mA}$	25°C		600	1000		600	1000	
		-40°C to 125°C			1700			1700	
	$V_{ON/OFF} < 0.3\text{ V (OFF)}$	25°C		0.01	0.8		0.01	0.8	
	$V_{ON/OFF} < 0.15\text{ V (OFF)}$	-40°C to 105°C			0.05	2		0.05	
-40°C to 125°C					5			5	
$V_{ON/OFF}$ ON/OFF input voltage <sup>(2)</sup>	High = O/P ON	25°C		1.4			1.4	V	
		-40°C to 125°C		1.6			1.6		
	Low = O/P OFF	25°C		0.5			0.5		
		-40°C to 125°C			0.15				0.15
$I_{ON/OFF}$ ON/OFF input current	$V_{ON/OFF} = 0$	25°C		0.01			0.01	$\mu\text{A}$	
		-40°C to 125°C			-1		-1		
	$V_{ON/OFF} = 5\text{ V}$	25°C		5			5		
		-40°C to 125°C			15				15
$I_{OUT(PK)}$ Peak output current	$V_{OUT} \geq V_{OUT(NOM)} - 5\%$	25°C	150	400		400		mA	
$V_n$ Output noise voltage (RMS)	BW = 300 Hz to 50 kHz, $C_{OUT} = 10\text{ }\mu\text{F}$	25°C		160		160		$\mu\text{V}$	
$\Delta V_{OUT}/\Delta V_{IN}$ Ripple rejection	f = 1 kHz, $C_{OUT} = 10\text{ }\mu\text{F}$	25°C		63		63		dB	
$I_{OUT(MAX)}$ Short-circuit current	$R_L = 0$ (steady state)	25°C		150		150		mA	

(1) Dropout voltage is defined as the input-to-output differential at which the output voltage drops 100 mV below the value measured with a 1-V differential. This dropout specification does not apply to the 1.8-V option, as the minimum  $V_{IN} = 2.2\text{ V}$  must be observed for proper biasing of LDO control circuitry.

(2) The ON/OFF input must be actively terminated. Connect to  $V_{IN}$  if this function is not used (see *Application Information*).

## APPLICATION INFORMATION

### Capacitors

#### Input Capacitor ( $C_{in}$ )

A minimum value of 1  $\mu\text{F}$  (over the entire operating temperature range) is required at the input of the LP2981. In addition, this input capacitor should be located within 1 cm of the input pin and connected to a clean analog ground. There is no Equivalent Series Resistance (ESR) requirement for this capacitor, and the capacitance can be increased without limit. A good quality ceramic or tantalum capacitor can be used.

#### Output Capacitor ( $C_{out}$ )

As a PNP regulator, the LP2981 requires the output capacitor to meet both a minimum capacitance and ESR value. Required ESR values as a function of load current are provided for various output voltages, load currents, and capacitances (see Figure 2 through Figure 5).

- Minimum  $C_{out}$ : 3.3  $\mu\text{F}$  (can be increased without limit to improve transient response stability margin)
- ESR range: see Figure 2 through Figure 5

It is critical that both the minimum capacitance and ESR requirement be met over the entire operating temperature range. Depending on the type of capacitor used, both of these parameters can vary significantly with temperature (see capacitor characteristics section).

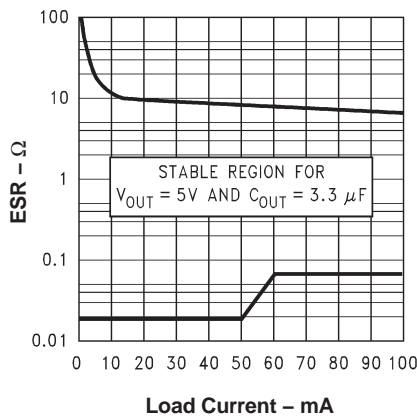

Figure 2. 5-V/3.3- $\mu\text{F}$  ESR Curves

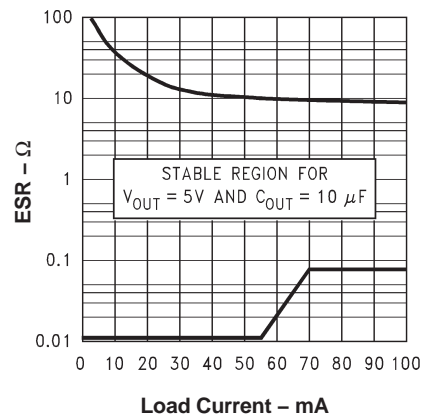

Figure 3. 5-V/10- $\mu\text{F}$  ESR Curves

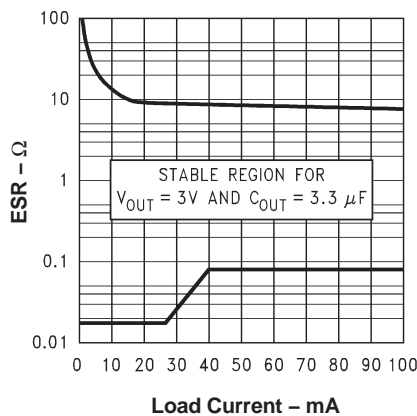

Figure 4. 3-V/3.3- $\mu\text{F}$  ESR Curves

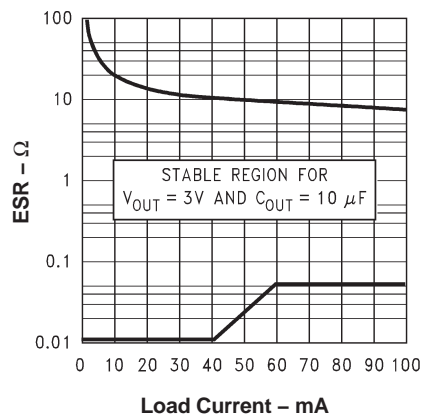

Figure 5. 3-V/10- $\mu\text{F}$  ESR Curves

## Capacitor Characteristics

### Ceramics

Due to their very low ESR values, ceramic capacitors are not suitable for use as the output capacitor. For instance, a typical 2.2- $\mu$ F ceramic capacitor has an ESR in the range of 10 m $\Omega$  to 20 m $\Omega$  and, thus, easily can fall out of minimum ESR requirements under certain operating conditions.

If a ceramic capacitor is used at the output, a 1- $\Omega$  resistor should be placed in series with the capacitor to raise the ESR seen by the regulator.

### Tantalum

Solid tantalum capacitors are optimal choices for the LP2981, but they still must meet the minimum ESR requirement. Note that the ESR of a tantalum capacitor increases as temperature drops, as much as doubling from 25°C to –40°C. Thus, ESR margins must be maintained over the temperature range to prevent regulator instability. For operation at very low temperatures, paralleling a tantalum capacitor with a ceramic one keeps the combined ESR from increasing near the upper limit of the ESR curve.

### Aluminum

Aluminum capacitors can be used, but use with the LP2981 is impractical due to their large physical dimensions. They also must meet the ESR requirements over the full temperature range. In this regard, aluminium capacitors are at a big disadvantage due to their sharp ESR increase as temperature drops. For example, over a temperature drop from 20°C to –40°C, the ESR of an aluminum electrolytic capacitor can increase by a factor of 50. In addition, some of the electrolytes used in these capacitors can freeze at –25°C, making the capacitor nonoperational.

## ON/ $\overline{\text{OFF}}$ Operation

The LP2981 allows for a shutdown mode via the ON/ $\overline{\text{OFF}}$  pin. If the shutdown feature is not used, ON/ $\overline{\text{OFF}}$  should be connected to the input to ensure that the regulator is on at all times. To drive ON/ $\overline{\text{OFF}}$ :

- A LOW ( $\leq 0.3$  V) turns the regulator OFF; a HIGH ( $\geq 1.6$  V) turns it ON.
- Use either a totem-pole output or an open-collector output with a pullup resistor tied to  $V_{\text{IN}}$  (or another logic supply). The HIGH signal can exceed  $V_{\text{IN}}$ , but must not exceed the absolute maximum ratings of 20 V for the ON/ $\overline{\text{OFF}}$  pin.
- Apply a signal with a slew rate of  $\geq 40$  mV/ $\mu$ s. A slow slew rate can cause the shutdown function to operate incorrectly.

## Reverse Input-Output Voltage

An inherent diode is present across the PNP pass element of the LP2981.

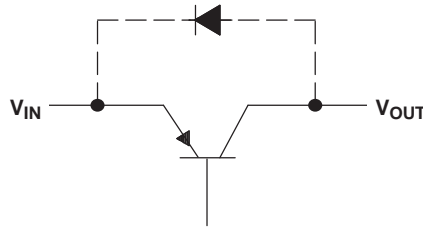

With the anode connected to the output, this diode is reverse biased during normal operation, since the input voltage is higher than the output. However, if the output is pulled one  $V_{BE}$  higher than the input, or if the input is abruptly stepped below the output, this diode is forward biased and can cause a parasitic silicon-controlled rectifier (SCR) to latch, resulting in current flowing from the output to the input (values in excess of 100 mA can cause damage). Thus, to prevent possible damage to the regulator in any application where the output may be pulled above the input, an external Schottky diode must be connected between the output and input. With the anode on output, this Schottky limits the reverse voltage across the output and input pins to  $\sim 0.3$  V, preventing the regulator's internal diode from forward biasing.

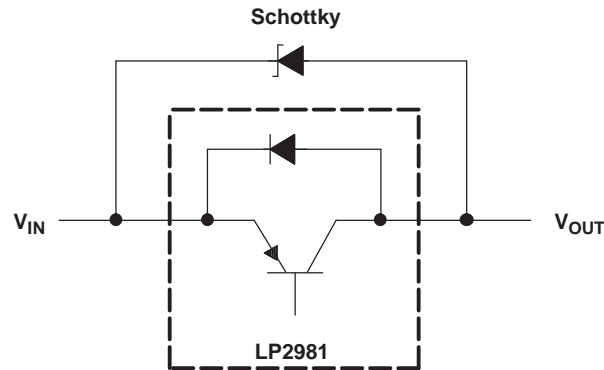

**PACKAGING INFORMATION**

Orderable Device	Status (1)	Package Type	Package Drawing	Pins	Package Qty	Eco Plan (2)	Lead/Ball Finish (6)	MSL Peak Temp (3)	Op Temp (°C)	Device Marking (4/5)	Samples
LP2981-28DBVR	ACTIVE	SOT-23	DBV	5	3000	Green (RoHS & no Sb/Br)	CU NIPDAU	Level-1-260C-UNLIM	-40 to 125	(LP53 ~ LP5G ~ LP5L)	<a href="#">Samples</a>
LP2981-28DBVRE4	ACTIVE	SOT-23	DBV	5		TBD	Call TI	Call TI	-40 to 125		<a href="#">Samples</a>
LP2981-28DBVRG4	ACTIVE	SOT-23	DBV	5		TBD	Call TI	Call TI	-40 to 125		<a href="#">Samples</a>
LP2981-28DBVT	ACTIVE	SOT-23	DBV	5	250	Green (RoHS & no Sb/Br)	CU NIPDAU	Level-1-260C-UNLIM	-40 to 125	(LP53 ~ LP5G ~ LP5L)	<a href="#">Samples</a>
LP2981-28DBVTE4	ACTIVE	SOT-23	DBV	5		TBD	Call TI	Call TI	-40 to 125		<a href="#">Samples</a>
LP2981-28DBVTG4	ACTIVE	SOT-23	DBV	5	250	Green (RoHS & no Sb/Br)	CU NIPDAU	Level-1-260C-UNLIM	-40 to 125	(LP53 ~ LP5G ~ LP5L)	<a href="#">Samples</a>
LP2981-29DBVR	ACTIVE	SOT-23	DBV	5	3000	Green (RoHS & no Sb/Br)	CU NIPDAU	Level-1-260C-UNLIM	-40 to 125	(LP33 ~ LP3G ~ LP3L)	<a href="#">Samples</a>
LP2981-29DBVRG4	ACTIVE	SOT-23	DBV	5		TBD	Call TI	Call TI	-40 to 125		<a href="#">Samples</a>
LP2981-29DBVT	ACTIVE	SOT-23	DBV	5	250	Green (RoHS & no Sb/Br)	CU NIPDAU	Level-1-260C-UNLIM	-40 to 125	(LP33 ~ LP3G ~ LP3L)	<a href="#">Samples</a>
LP2981-29DBVTG4	ACTIVE	SOT-23	DBV	5		TBD	Call TI	Call TI	-40 to 125		<a href="#">Samples</a>
LP2981-30DBVR	ACTIVE	SOT-23	DBV	5	3000	Green (RoHS & no Sb/Br)	CU NIPDAU	Level-1-260C-UNLIM	-40 to 125	(LP73 ~ LP7G ~ LP7L)	<a href="#">Samples</a>
LP2981-30DBVRE4	ACTIVE	SOT-23	DBV	5		TBD	Call TI	Call TI	-40 to 125		<a href="#">Samples</a>
LP2981-30DBVRG4	ACTIVE	SOT-23	DBV	5		TBD	Call TI	Call TI	-40 to 125		<a href="#">Samples</a>
LP2981-30DBVT	ACTIVE	SOT-23	DBV	5	250	Green (RoHS & no Sb/Br)	CU NIPDAU	Level-1-260C-UNLIM	-40 to 125	(LP73 ~ LP7G ~ LP7L)	<a href="#">Samples</a>
LP2981-30DBVTE4	ACTIVE	SOT-23	DBV	5	250	Green (RoHS & no Sb/Br)	CU NIPDAU	Level-1-260C-UNLIM	-40 to 125	(LP73 ~ LP7G ~ LP7L)	<a href="#">Samples</a>
LP2981-30DBVTG4	ACTIVE	SOT-23	DBV	5		TBD	Call TI	Call TI	-40 to 125		<a href="#">Samples</a>
LP2981-33DBVR	ACTIVE	SOT-23	DBV	5	3000	Green (RoHS & no Sb/Br)	CU NIPDAU	Level-1-260C-UNLIM	-40 to 125	(LPB3 ~ LPBG ~ LPBL)	<a href="#">Samples</a>
LP2981-33DBVRE4	ACTIVE	SOT-23	DBV	5		TBD	Call TI	Call TI	-40 to 125		<a href="#">Samples</a>
LP2981-33DBVRG4	ACTIVE	SOT-23	DBV	5		TBD	Call TI	Call TI	-40 to 125		<a href="#">Samples</a>

Orderable Device	Status (1)	Package Type	Package Drawing	Pins	Package Qty	Eco Plan (2)	Lead/Ball Finish (6)	MSL Peak Temp (3)	Op Temp (°C)	Device Marking (4/5)	Samples
LP2981-33DBVT	ACTIVE	SOT-23	DBV	5	250	Green (RoHS & no Sb/Br)	CU NIPDAU	Level-1-260C-UNLIM	-40 to 125	(LPB3 ~ LPBG ~ LPBL)	<a href="#">Samples</a>
LP2981-33DBVTE4	ACTIVE	SOT-23	DBV	5	250	Green (RoHS & no Sb/Br)	CU NIPDAU	Level-1-260C-UNLIM	-40 to 125	(LPB3 ~ LPBG ~ LPBL)	<a href="#">Samples</a>
LP2981-33DBVTG4	ACTIVE	SOT-23	DBV	5	250	Green (RoHS & no Sb/Br)	CU NIPDAU	Level-1-260C-UNLIM	-40 to 125	(LPB3 ~ LPBG ~ LPBL)	<a href="#">Samples</a>
LP2981-50DBVR	ACTIVE	SOT-23	DBV	5	3000	Green (RoHS & no Sb/Br)	CU NIPDAU	Level-1-260C-UNLIM	-40 to 125	(LPD3 ~ LPDG ~ LPDL)	<a href="#">Samples</a>
LP2981-50DBVRG4	ACTIVE	SOT-23	DBV	5	3000	Green (RoHS & no Sb/Br)	CU NIPDAU	Level-1-260C-UNLIM	-40 to 125	(LPD3 ~ LPDG ~ LPDL)	<a href="#">Samples</a>
LP2981-50DBVT	ACTIVE	SOT-23	DBV	5	250	Green (RoHS & no Sb/Br)	CU NIPDAU	Level-1-260C-UNLIM	-40 to 125	(LPD3 ~ LPDG ~ LPDL)	<a href="#">Samples</a>
LP2981-50DBVTG4	ACTIVE	SOT-23	DBV	5	250	Green (RoHS & no Sb/Br)	CU NIPDAU	Level-1-260C-UNLIM	-40 to 125	(LPD3 ~ LPDG ~ LPDL)	<a href="#">Samples</a>
LP2981A-28DBVR	ACTIVE	SOT-23	DBV	5	3000	Green (RoHS & no Sb/Br)	CU NIPDAU	Level-1-260C-UNLIM	-40 to 125	(LP63 ~ LP6G ~ LP6L)	<a href="#">Samples</a>
LP2981A-28DBVRE4	ACTIVE	SOT-23	DBV	5		TBD	Call TI	Call TI	-40 to 125		<a href="#">Samples</a>
LP2981A-28DBVRG4	ACTIVE	SOT-23	DBV	5		TBD	Call TI	Call TI	-40 to 125		<a href="#">Samples</a>
LP2981A-28DBVT	ACTIVE	SOT-23	DBV	5	250	Green (RoHS & no Sb/Br)	CU NIPDAU	Level-1-260C-UNLIM	-40 to 125	(LP63 ~ LP6G ~ LP6L)	<a href="#">Samples</a>
LP2981A-28DBVTE4	ACTIVE	SOT-23	DBV	5		TBD	Call TI	Call TI	-40 to 125		<a href="#">Samples</a>
LP2981A-28DBVTG4	ACTIVE	SOT-23	DBV	5		TBD	Call TI	Call TI	-40 to 125		<a href="#">Samples</a>
LP2981A-29DBVR	ACTIVE	SOT-23	DBV	5	3000	Green (RoHS & no Sb/Br)	CU NIPDAU	Level-1-260C-UNLIM	-40 to 125	(LRB3 ~ LRBG ~ LRBL)	<a href="#">Samples</a>
LP2981A-29DBVRG4	ACTIVE	SOT-23	DBV	5		TBD	Call TI	Call TI	-40 to 125		<a href="#">Samples</a>
LP2981A-29DBVT	ACTIVE	SOT-23	DBV	5	250	Green (RoHS & no Sb/Br)	CU NIPDAU	Level-1-260C-UNLIM	-40 to 125	(LRB3 ~ LRBG ~ LRBL)	<a href="#">Samples</a>
LP2981A-29DBVTG4	ACTIVE	SOT-23	DBV	5		TBD	Call TI	Call TI	-40 to 125		<a href="#">Samples</a>
LP2981A-30DBVR	ACTIVE	SOT-23	DBV	5	3000	Green (RoHS & no Sb/Br)	CU NIPDAU	Level-1-260C-UNLIM	-40 to 125	(LP83 ~ LP8G ~ LP8L)	<a href="#">Samples</a>
LP2981A-30DBVRE4	ACTIVE	SOT-23	DBV	5		TBD	Call TI	Call TI	-40 to 125		<a href="#">Samples</a>

Orderable Device	Status (1)	Package Type	Package Drawing	Pins	Package Qty	Eco Plan (2)	Lead/Ball Finish (6)	MSL Peak Temp (3)	Op Temp (°C)	Device Marking (4/5)	Samples
LP2981A-30DBVRG4	ACTIVE	SOT-23	DBV	5	3000	Green (RoHS & no Sb/Br)	CU NIPDAU	Level-1-260C-UNLIM	-40 to 125	(LP83 ~ LP8G ~ LP8L)	<a href="#">Samples</a>
LP2981A-30DBVT	ACTIVE	SOT-23	DBV	5	250	Green (RoHS & no Sb/Br)	CU NIPDAU	Level-1-260C-UNLIM	-40 to 125	(LP83 ~ LP8G ~ LP8L)	<a href="#">Samples</a>
LP2981A-30DBVTE4	ACTIVE	SOT-23	DBV	5		TBD	Call TI	Call TI	-40 to 125		<a href="#">Samples</a>
LP2981A-30DBVTG4	ACTIVE	SOT-23	DBV	5	250	Green (RoHS & no Sb/Br)	CU NIPDAU	Level-1-260C-UNLIM	-40 to 125	(LP83 ~ LP8G ~ LP8L)	<a href="#">Samples</a>
LP2981A-33DBVR	ACTIVE	SOT-23	DBV	5	3000	Green (RoHS & no Sb/Br)	CU NIPDAU	Level-1-260C-UNLIM	-40 to 125	(LPC3 ~ LPCG ~ LPCL)	<a href="#">Samples</a>
LP2981A-33DBVRE4	ACTIVE	SOT-23	DBV	5		TBD	Call TI	Call TI	-40 to 125		<a href="#">Samples</a>
LP2981A-33DBVRG4	ACTIVE	SOT-23	DBV	5	3000	Green (RoHS & no Sb/Br)	CU NIPDAU	Level-1-260C-UNLIM	-40 to 125	(LPC3 ~ LPCG ~ LPCL)	<a href="#">Samples</a>
LP2981A-33DBVT	ACTIVE	SOT-23	DBV	5	250	Green (RoHS & no Sb/Br)	CU NIPDAU	Level-1-260C-UNLIM	-40 to 125	(LPC3 ~ LPCG ~ LPCL)	<a href="#">Samples</a>
LP2981A-33DBVTE4	ACTIVE	SOT-23	DBV	5	250	Green (RoHS & no Sb/Br)	CU NIPDAU	Level-1-260C-UNLIM	-40 to 125	(LPC3 ~ LPCG ~ LPCL)	<a href="#">Samples</a>
LP2981A-33DBVTG4	ACTIVE	SOT-23	DBV	5	250	Green (RoHS & no Sb/Br)	CU NIPDAU	Level-1-260C-UNLIM	-40 to 125	(LPC3 ~ LPCG ~ LPCL)	<a href="#">Samples</a>
LP2981A-50DBVR	ACTIVE	SOT-23	DBV	5	3000	Green (RoHS & no Sb/Br)	CU NIPDAU	Level-1-260C-UNLIM	-40 to 125	(LPE3 ~ LPEG ~ LPEL)	<a href="#">Samples</a>
LP2981A-50DBVRG4	ACTIVE	SOT-23	DBV	5	3000	Green (RoHS & no Sb/Br)	CU NIPDAU	Level-1-260C-UNLIM	-40 to 125	(LPE3 ~ LPEG ~ LPEL)	<a href="#">Samples</a>
LP2981A-50DBVT	ACTIVE	SOT-23	DBV	5	250	Green (RoHS & no Sb/Br)	CU NIPDAU	Level-1-260C-UNLIM	-40 to 125	(LPE3 ~ LPEG ~ LPEL)	<a href="#">Samples</a>
LP2981A-50DBVTG4	ACTIVE	SOT-23	DBV	5	250	Green (RoHS & no Sb/Br)	CU NIPDAU	Level-1-260C-UNLIM	-40 to 125	(LPE3 ~ LPEG ~ LPEL)	<a href="#">Samples</a>

(1) The marketing status values are defined as follows:

**ACTIVE:** Product device recommended for new designs.

**LIFEBUY:** TI has announced that the device will be discontinued, and a lifetime-buy period is in effect.

**NRND:** Not recommended for new designs. Device is in production to support existing customers, but TI does not recommend using this part in a new design.

**PREVIEW:** Device has been announced but is not in production. Samples may or may not be available.

**OBsolete:** TI has discontinued the production of the device.

(2) Eco Plan - The planned eco-friendly classification: Pb-Free (RoHS), Pb-Free (RoHS Exempt), or Green (RoHS & no Sb/Br) - please check <http://www.ti.com/productcontent> for the latest availability information and additional product content details.

---

**TBD:** The Pb-Free/Green conversion plan has not been defined.

**Pb-Free (RoHS):** TI's terms "Lead-Free" or "Pb-Free" mean semiconductor products that are compatible with the current RoHS requirements for all 6 substances, including the requirement that lead not exceed 0.1% by weight in homogeneous materials. Where designed to be soldered at high temperatures, TI Pb-Free products are suitable for use in specified lead-free processes.

**Pb-Free (RoHS Exempt):** This component has a RoHS exemption for either 1) lead-based flip-chip solder bumps used between the die and package, or 2) lead-based die adhesive used between the die and leadframe. The component is otherwise considered Pb-Free (RoHS compatible) as defined above.

**Green (RoHS & no Sb/Br):** TI defines "Green" to mean Pb-Free (RoHS compatible), and free of Bromine (Br) and Antimony (Sb) based flame retardants (Br or Sb do not exceed 0.1% by weight in homogeneous material)

(3) MSL, Peak Temp. - The Moisture Sensitivity Level rating according to the JEDEC industry standard classifications, and peak solder temperature.

(4) There may be additional marking, which relates to the logo, the lot trace code information, or the environmental category on the device.

(5) Multiple Device Markings will be inside parentheses. Only one Device Marking contained in parentheses and separated by a "~" will appear on a device. If a line is indented then it is a continuation of the previous line and the two combined represent the entire Device Marking for that device.

(6) Lead/Ball Finish - Orderable Devices may have multiple material finish options. Finish options are separated by a vertical ruled line. Lead/Ball Finish values may wrap to two lines if the finish value exceeds the maximum column width.

**Important Information and Disclaimer:**The information provided on this page represents TI's knowledge and belief as of the date that it is provided. TI bases its knowledge and belief on information provided by third parties, and makes no representation or warranty as to the accuracy of such information. Efforts are underway to better integrate information from third parties. TI has taken and continues to take reasonable steps to provide representative and accurate information but may not have conducted destructive testing or chemical analysis on incoming materials and chemicals. TI and TI suppliers consider certain information to be proprietary, and thus CAS numbers and other limited information may not be available for release.

In no event shall TI's liability arising out of such information exceed the total purchase price of the TI part(s) at issue in this document sold by TI to Customer on an annual basis.

**TAPE AND REEL INFORMATION**
**REEL DIMENSIONS**

**TAPE DIMENSIONS**

A0	Dimension designed to accommodate the component width
B0	Dimension designed to accommodate the component length
K0	Dimension designed to accommodate the component thickness
W	Overall width of the carrier tape
P1	Pitch between successive cavity centers

**TAPE AND REEL INFORMATION**

\*All dimensions are nominal

Device	Package Type	Package Drawing	Pins	SPQ	Reel Diameter (mm)	Reel Width W1 (mm)	A0 (mm)	B0 (mm)	K0 (mm)	P1 (mm)	W (mm)	Pin1 Quadrant
LP2981-28DBVR	SOT-23	DBV	5	3000	180.0	9.2	3.17	3.23	1.37	4.0	8.0	Q3
LP2981-28DBVR	SOT-23	DBV	5	3000	178.0	9.0	3.23	3.17	1.37	4.0	8.0	Q3
LP2981-28DBVT	SOT-23	DBV	5	250	180.0	9.2	3.17	3.23	1.37	4.0	8.0	Q3
LP2981-29DBVR	SOT-23	DBV	5	3000	180.0	9.2	3.17	3.23	1.37	4.0	8.0	Q3
LP2981-29DBVT	SOT-23	DBV	5	250	180.0	9.2	3.17	3.23	1.37	4.0	8.0	Q3
LP2981-30DBVR	SOT-23	DBV	5	3000	180.0	9.2	3.17	3.23	1.37	4.0	8.0	Q3
LP2981-30DBVR	SOT-23	DBV	5	3000	178.0	9.0	3.23	3.17	1.37	4.0	8.0	Q3
LP2981-30DBVT	SOT-23	DBV	5	250	180.0	9.2	3.17	3.23	1.37	4.0	8.0	Q3
LP2981-33DBVR	SOT-23	DBV	5	3000	178.0	9.0	3.23	3.17	1.37	4.0	8.0	Q3
LP2981-33DBVR	SOT-23	DBV	5	3000	180.0	9.2	3.17	3.23	1.37	4.0	8.0	Q3
LP2981-33DBVT	SOT-23	DBV	5	250	180.0	9.2	3.17	3.23	1.37	4.0	8.0	Q3
LP2981-50DBVR	SOT-23	DBV	5	3000	180.0	9.2	3.17	3.23	1.37	4.0	8.0	Q3
LP2981-50DBVT	SOT-23	DBV	5	250	180.0	9.2	3.17	3.23	1.37	4.0	8.0	Q3
LP2981A-28DBVR	SOT-23	DBV	5	3000	178.0	9.0	3.23	3.17	1.37	4.0	8.0	Q3
LP2981A-28DBVR	SOT-23	DBV	5	3000	180.0	9.2	3.17	3.23	1.37	4.0	8.0	Q3
LP2981A-28DBVT	SOT-23	DBV	5	250	180.0	9.2	3.17	3.23	1.37	4.0	8.0	Q3
LP2981A-29DBVR	SOT-23	DBV	5	3000	180.0	9.2	3.17	3.23	1.37	4.0	8.0	Q3
LP2981A-29DBVT	SOT-23	DBV	5	250	180.0	9.2	3.17	3.23	1.37	4.0	8.0	Q3

Device	Package Type	Package Drawing	Pins	SPQ	Reel Diameter (mm)	Reel Width W1 (mm)	A0 (mm)	B0 (mm)	K0 (mm)	P1 (mm)	W (mm)	Pin1 Quadrant
LP2981A-30DBVR	SOT-23	DBV	5	3000	180.0	9.2	3.17	3.23	1.37	4.0	8.0	Q3
LP2981A-30DBVT	SOT-23	DBV	5	250	180.0	9.2	3.17	3.23	1.37	4.0	8.0	Q3
LP2981A-33DBVR	SOT-23	DBV	5	3000	180.0	9.2	3.17	3.23	1.37	4.0	8.0	Q3
LP2981A-33DBVT	SOT-23	DBV	5	250	180.0	9.2	3.17	3.23	1.37	4.0	8.0	Q3
LP2981A-50DBVR	SOT-23	DBV	5	3000	180.0	9.2	3.17	3.23	1.37	4.0	8.0	Q3
LP2981A-50DBVT	SOT-23	DBV	5	250	180.0	9.2	3.17	3.23	1.37	4.0	8.0	Q3

## TAPE AND REEL BOX DIMENSIONS

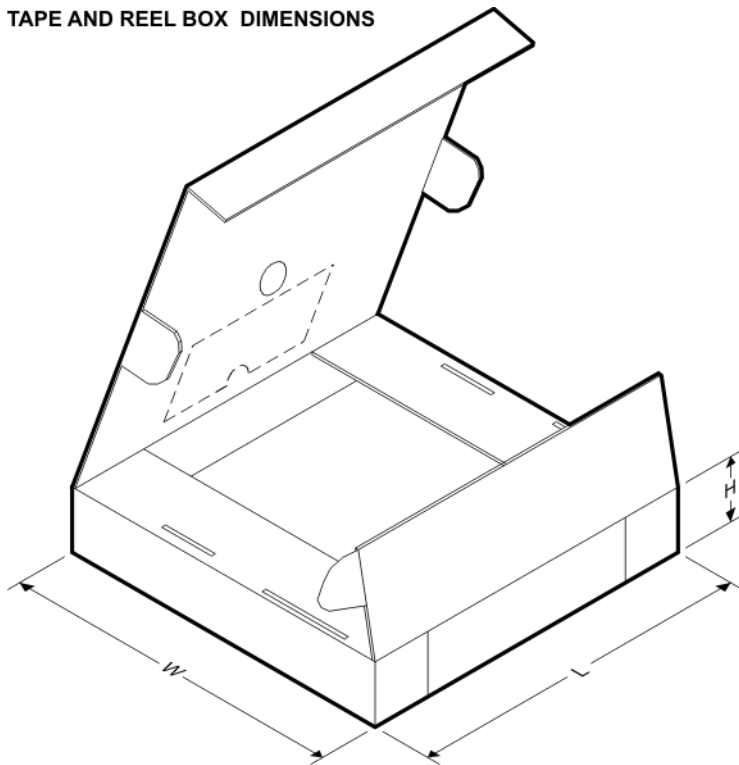

\*All dimensions are nominal

Device	Package Type	Package Drawing	Pins	SPQ	Length (mm)	Width (mm)	Height (mm)
LP2981-28DBVR	SOT-23	DBV	5	3000	205.0	200.0	33.0
LP2981-28DBVT	SOT-23	DBV	5	250	205.0	200.0	33.0
LP2981-29DBVR	SOT-23	DBV	5	3000	205.0	200.0	33.0
LP2981-29DBVT	SOT-23	DBV	5	250	205.0	200.0	33.0
LP2981-30DBVR	SOT-23	DBV	5	3000	205.0	200.0	33.0
LP2981-30DBVT	SOT-23	DBV	5	250	205.0	200.0	33.0
LP2981-33DBVR	SOT-23	DBV	5	3000	180.0	180.0	18.0
LP2981-33DBVT	SOT-23	DBV	5	250	180.0	180.0	18.0

Device	Package Type	Package Drawing	Pins	SPQ	Length (mm)	Width (mm)	Height (mm)
LP2981-50DBVR	SOT-23	DBV	5	3000	205.0	200.0	33.0
LP2981-50DBVT	SOT-23	DBV	5	250	205.0	200.0	33.0
LP2981A-28DBVR	SOT-23	DBV	5	3000	180.0	180.0	18.0
LP2981A-28DBVR	SOT-23	DBV	5	3000	205.0	200.0	33.0
LP2981A-28DBVT	SOT-23	DBV	5	250	205.0	200.0	33.0
LP2981A-29DBVR	SOT-23	DBV	5	3000	205.0	200.0	33.0
LP2981A-29DBVT	SOT-23	DBV	5	250	205.0	200.0	33.0
LP2981A-30DBVR	SOT-23	DBV	5	3000	205.0	200.0	33.0
LP2981A-30DBVT	SOT-23	DBV	5	250	205.0	200.0	33.0
LP2981A-33DBVR	SOT-23	DBV	5	3000	205.0	200.0	33.0
LP2981A-33DBVT	SOT-23	DBV	5	250	205.0	200.0	33.0
LP2981A-50DBVR	SOT-23	DBV	5	3000	205.0	200.0	33.0
LP2981A-50DBVT	SOT-23	DBV	5	250	205.0	200.0	33.0

DBV (R-PDSO-G5)

PLASTIC SMALL-OUTLINE PACKAGE

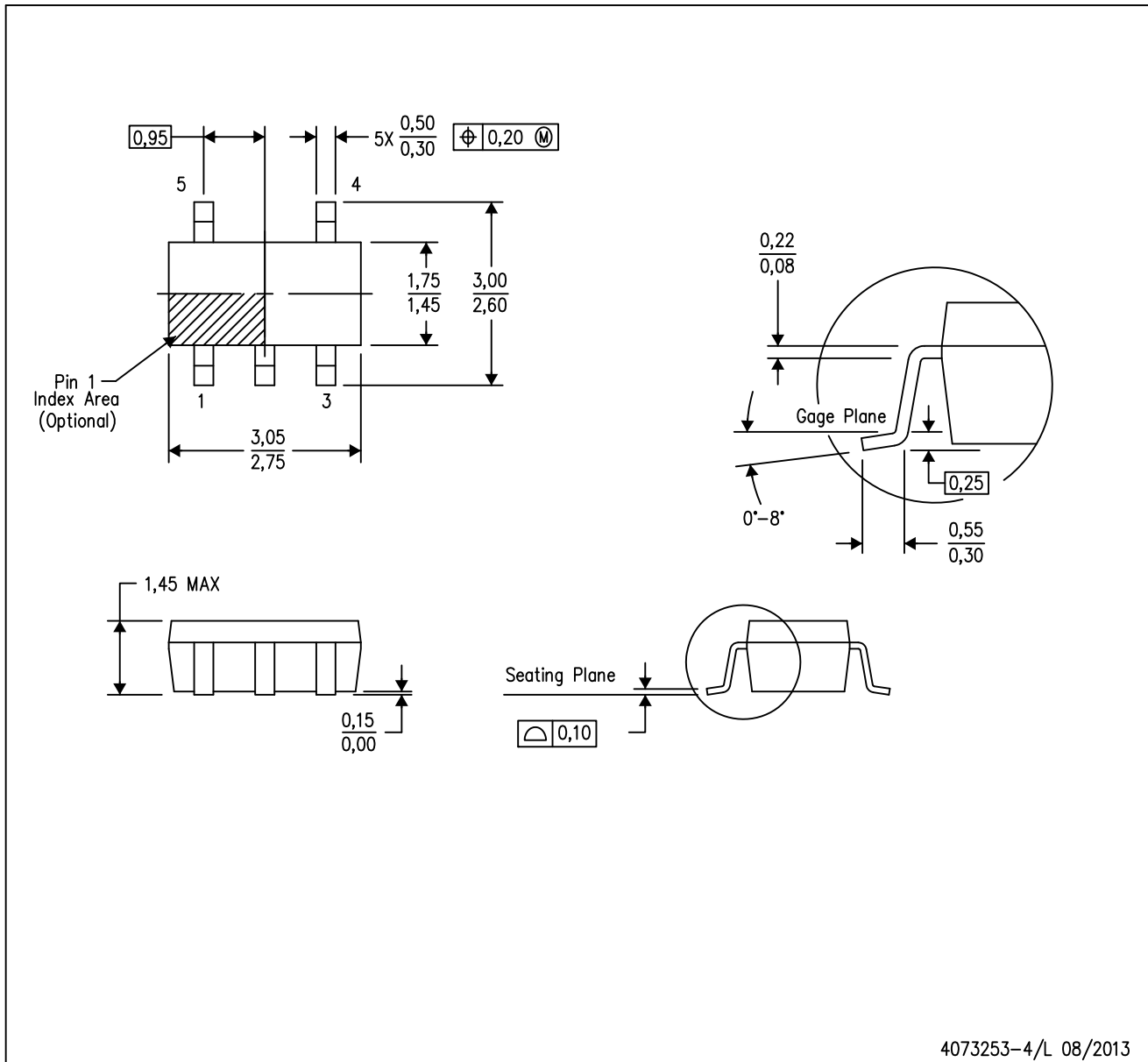

4073253-4/L 08/2013

- NOTES:
- A. All linear dimensions are in millimeters.
  - B. This drawing is subject to change without notice.
  - C. Body dimensions do not include mold flash or protrusion. Mold flash and protrusion shall not exceed 0.15 per side.
  - D. Falls within JEDEC MO-178 Variation AA.

DBV (R-PDSO-G5)

PLASTIC SMALL OUTLINE



- NOTES:
- A. All linear dimensions are in millimeters.
  - B. This drawing is subject to change without notice.
  - C. Customers should place a note on the circuit board fabrication drawing not to alter the center solder mask defined pad.
  - D. Publication IPC-7351 is recommended for alternate designs.
  - E. Laser cutting apertures with trapezoidal walls and also rounding corners will offer better paste release. Customers should contact their board assembly site for stencil design recommendations. Example stencil design based on a 50% volumetric metal load solder paste. Refer to IPC-7525 for other stencil recommendations.

## IMPORTANT NOTICE

Texas Instruments Incorporated and its subsidiaries (TI) reserve the right to make corrections, enhancements, improvements and other changes to its semiconductor products and services per JESD46, latest issue, and to discontinue any product or service per JESD48, latest issue. Buyers should obtain the latest relevant information before placing orders and should verify that such information is current and complete. All semiconductor products (also referred to herein as "components") are sold subject to TI's terms and conditions of sale supplied at the time of order acknowledgment.

TI warrants performance of its components to the specifications applicable at the time of sale, in accordance with the warranty in TI's terms and conditions of sale of semiconductor products. Testing and other quality control techniques are used to the extent TI deems necessary to support this warranty. Except where mandated by applicable law, testing of all parameters of each component is not necessarily performed.

TI assumes no liability for applications assistance or the design of Buyers' products. Buyers are responsible for their products and applications using TI components. To minimize the risks associated with Buyers' products and applications, Buyers should provide adequate design and operating safeguards.

TI does not warrant or represent that any license, either express or implied, is granted under any patent right, copyright, mask work right, or other intellectual property right relating to any combination, machine, or process in which TI components or services are used. Information published by TI regarding third-party products or services does not constitute a license to use such products or services or a warranty or endorsement thereof. Use of such information may require a license from a third party under the patents or other intellectual property of the third party, or a license from TI under the patents or other intellectual property of TI.

Reproduction of significant portions of TI information in TI data books or data sheets is permissible only if reproduction is without alteration and is accompanied by all associated warranties, conditions, limitations, and notices. TI is not responsible or liable for such altered documentation. Information of third parties may be subject to additional restrictions.

Resale of TI components or services with statements different from or beyond the parameters stated by TI for that component or service voids all express and any implied warranties for the associated TI component or service and is an unfair and deceptive business practice. TI is not responsible or liable for any such statements.

Buyer acknowledges and agrees that it is solely responsible for compliance with all legal, regulatory and safety-related requirements concerning its products, and any use of TI components in its applications, notwithstanding any applications-related information or support that may be provided by TI. Buyer represents and agrees that it has all the necessary expertise to create and implement safeguards which anticipate dangerous consequences of failures, monitor failures and their consequences, lessen the likelihood of failures that might cause harm and take appropriate remedial actions. Buyer will fully indemnify TI and its representatives against any damages arising out of the use of any TI components in safety-critical applications.

In some cases, TI components may be promoted specifically to facilitate safety-related applications. With such components, TI's goal is to help enable customers to design and create their own end-product solutions that meet applicable functional safety standards and requirements. Nonetheless, such components are subject to these terms.

No TI components are authorized for use in FDA Class III (or similar life-critical medical equipment) unless authorized officers of the parties have executed a special agreement specifically governing such use.

Only those TI components which TI has specifically designated as military grade or "enhanced plastic" are designed and intended for use in military/aerospace applications or environments. Buyer acknowledges and agrees that any military or aerospace use of TI components which have **not** been so designated is solely at the Buyer's risk, and that Buyer is solely responsible for compliance with all legal and regulatory requirements in connection with such use.

TI has specifically designated certain components as meeting ISO/TS16949 requirements, mainly for automotive use. In any case of use of non-designated products, TI will not be responsible for any failure to meet ISO/TS16949.

### Products

Audio	<a href="http://www.ti.com/audio">www.ti.com/audio</a>
Amplifiers	<a href="http://amplifier.ti.com">amplifier.ti.com</a>
Data Converters	<a href="http://dataconverter.ti.com">dataconverter.ti.com</a>
DLP® Products	<a href="http://www.dlp.com">www.dlp.com</a>
DSP	<a href="http://dsp.ti.com">dsp.ti.com</a>
Clocks and Timers	<a href="http://www.ti.com/clocks">www.ti.com/clocks</a>
Interface	<a href="http://interface.ti.com">interface.ti.com</a>
Logic	<a href="http://logic.ti.com">logic.ti.com</a>
Power Mgmt	<a href="http://power.ti.com">power.ti.com</a>
Microcontrollers	<a href="http://microcontroller.ti.com">microcontroller.ti.com</a>
RFID	<a href="http://www.ti-rfid.com">www.ti-rfid.com</a>
OMAP Applications Processors	<a href="http://www.ti.com/omap">www.ti.com/omap</a>
Wireless Connectivity	<a href="http://www.ti.com/wirelessconnectivity">www.ti.com/wirelessconnectivity</a>

### Applications

Automotive and Transportation	<a href="http://www.ti.com/automotive">www.ti.com/automotive</a>
Communications and Telecom	<a href="http://www.ti.com/communications">www.ti.com/communications</a>
Computers and Peripherals	<a href="http://www.ti.com/computers">www.ti.com/computers</a>
Consumer Electronics	<a href="http://www.ti.com/consumer-apps">www.ti.com/consumer-apps</a>
Energy and Lighting	<a href="http://www.ti.com/energy">www.ti.com/energy</a>
Industrial	<a href="http://www.ti.com/industrial">www.ti.com/industrial</a>
Medical	<a href="http://www.ti.com/medical">www.ti.com/medical</a>
Security	<a href="http://www.ti.com/security">www.ti.com/security</a>
Space, Avionics and Defense	<a href="http://www.ti.com/space-avionics-defense">www.ti.com/space-avionics-defense</a>
Video and Imaging	<a href="http://www.ti.com/video">www.ti.com/video</a>

### TI E2E Community

[e2e.ti.com](http://e2e.ti.com)

## Looking for pricing, stock, or lifecycle information?

Click below to explore more details on WIN SOURCE:

 [View LP2981-28DBVRG4 on WIN SOURCE](#)

 [Texas Instruments](#) Information

## Optimize Your Supply Chain with WIN SOURCE Solutions

-  Global Sourcing Solution
-  Obsolete Management
-  Cost Control Management
-  Shortage Management
-  Alternative Solution
-  Excess Inventory Management