

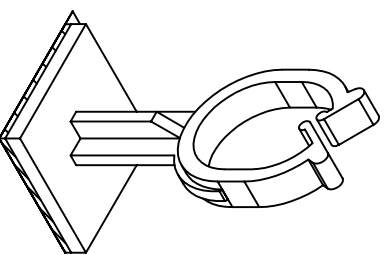

**THE DATASHEET OF
SHKBS-8-01A-RT**

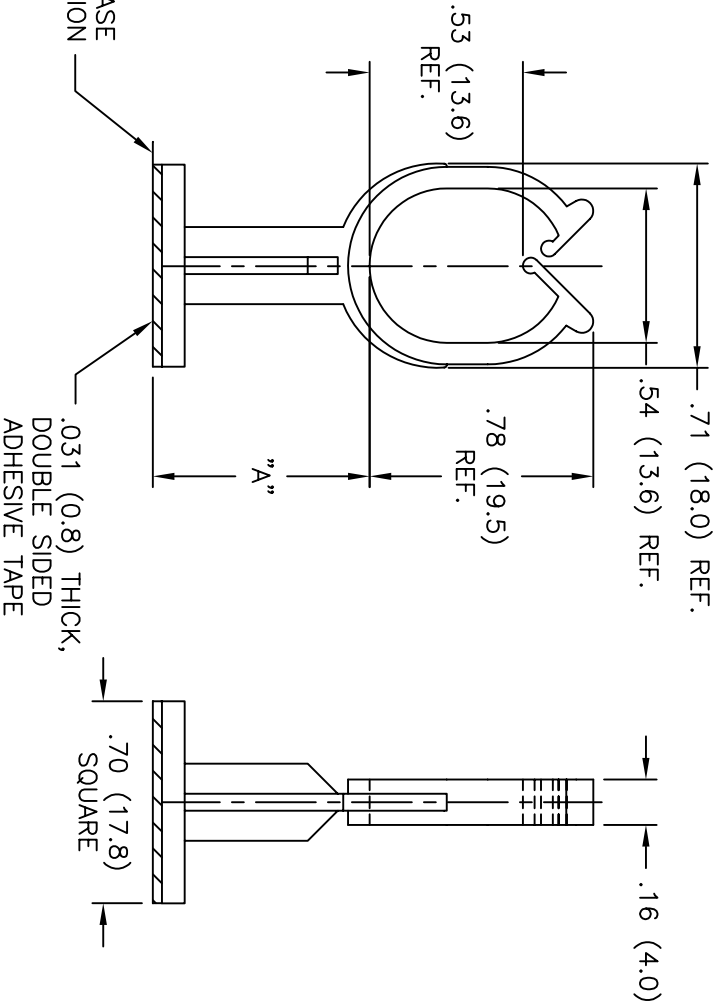

PART NO.	DIM. "A"
SHKBS-4-01A-RT	.25 (6.4)
SHKBS-8-01A-RT	.50 (12.7)
SHKBS-12-01A-RT	.75 (19.1)
SHKBS-16-01A-RT	1.00 (25.4)



TITLE: STANDOFF HARNESS CLIP ON ADHESIVE BASE

TOLERANCES UNLESS NOTED .XX=±.010 .XXX=±.005 FRAC=±1/64 ANG=±1°	FILE # SHKBS MAT'L: SEE NOTES RE: RICHCO, INC.	DWN: SM DT: 04/03/02	APP: DT:	PART # SEE TABLE	DWG IN IN (MM) FINAL	PRINT TYPE CA
---	--	-------------------------	----------	---------------------	-------------------------	------------------

(REV. "A") SM 04.03.02 ENGR DATE

Looking for pricing, stock, or lifecycle information?

Click below to explore more details on WIN SOURCE:

- ⊖ [View SHKBS-8-01A-RT on WIN SOURCE](#)
- ⊖ [Essentra Components Information](#)

Optimize Your Supply Chain with WIN SOURCE Solutions

- ✓ Global Sourcing Solution
- ✓ Obsolete Management
- ✓ Cost Control Management
- ✓ Shortage Management
- ✓ Alternative Solution
- ✓ Excess Inventory Management