



**THE DATASHEET OF
SPF-2086TK**



Product Description

Sirenza Microdevices' SPF-2086TK is a high performance 0.25 μ m pHEMT Gallium Arsenide FET with Schottky barrier gates. This 300 μ m device is ideally biased at 3V,20mA for lowest noise performance and battery powered requirements. At 5V,40mA the device delivers excellent output TOI of 32 dBm. It provides ideal performance as driver stages in many commercial, industrial and military LNA applications.

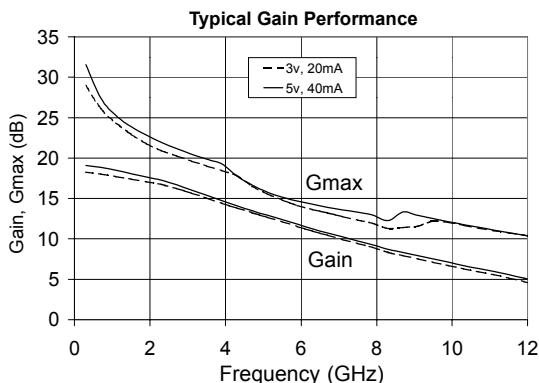

SPF-2086TK

Low Noise pHEMT GaAs FET 0.1 - 6 GHz Operation



Product Features

- 22 dB G_{max} at 1.9 GHz
- 0.4 dB F_{MIN} at 1.9 GHz
- +32 dBm Output IP3
- +20 dBm Output Power at 1dB Compression

Applications

- LNA for Analog and Digital Wireless Systems
- 3G, Cellular, PCS
- Fixed Wireless, Pager Systems
- Driver Stage for low power applications

Symbol	Device Characteristics, T = 25°C V _{DS} =3V, I _{DD} =20mA (unless otherwise noted)	Test Condition [1] = 100% Tested	Units	Min.	Typ.	Max.
G _{max}	Maximum Available Gain Z _S =Z _S *, Z _L =Z _L *	f = 0.9 GHz f = 1.9 GHz f = 4.0 GHz f = 6.0 GHz	dB dB dB dB	- - - -	25.2 21.8 18.7 13.5	- - - -
S ₂₁	Insertion Gain Z _S =Z _L = 50 Ohms	f = 1.9 GHz [1]	dB	16.0	17.7	19.4
F _{MIN}	Minimum Noise Figure Z _S =Γ _{OPT} , Z _L =Z _{LOPT}	f = 1 GHz f = 2 GHz f = 4 GHz f = 6 GHz	dB dB dB dB	- - - -	0.3 0.4 0.5 0.7	- - - -
OIP3	Output Third Order Intercept Point Z _S =Z _{SOPT} , Z _L =Z _{LOPT}	V _{DS} =5.0V, I _{DD} =40mA V _{DS} =3.0V, I _{DD} =20mA	dBm dBm	- -	32 28	- -
P1dB	Output 1dB Compression Point Z _S =Z _{SOPT} , Z _L =Z _{LOPT}	V _{DS} =5.0V, I _{DD} =40mA V _{DS} =3.0V, I _{DD} =20mA	dBm dBm	- -	20 15	- -
I _{DSS}	Saturated Drain Current V _{DS} = V _{DSP} , V _{GS} = 0V		mA	30	85	140
g _m	Transconductance: V _{DS} = V _{DSP} , V _{GS} = -0.25V		mS	-	112	-
V _P	Pinch-Off Voltage: V _{DS} = 2.0V, I _{DS} = 150 μ A	[1]	V	-1.5	-1.0	-0.5
BV _{GS}	Gate-to-Source Breakdown Voltage I _{GS} = 0.3mA, drain open	[1]	V	-	-17	-8
BV _{GD}	Gate-to-Drain Breakdown Voltage I _{GD} = 0.3mA, V _{GS} = -3.0V	[1]	V	-	-17	-8
R _{th}	Thermal Resistance, junction-to-lead		°C/W	-	110	-

The information provided herein is believed to be reliable at press time. Sirenza Microdevices assumes no responsibility for inaccuracies or omissions. Sirenza Microdevices assumes no responsibility for the use of this information, and all such information shall be entirely at the user's own risk. Prices and specifications are subject to change without notice. No patent rights or licenses to any of the circuits described herein are implied or granted to any third party. Sirenza Microdevices does not authorize or warrant any Sirenza Microdevices product for use in life-support devices and/or systems. Copyright 2003 Sirenza Microdevices, Inc. All worldwide rights reserved.

Absolute Maximum Ratings

Operation of this device beyond any one of these parameters may cause permanent damage.

MTTF is inversely proportional to the device junction temperature. For junction temperature and MTTF considerations the operating conditions should also satisfy the following expressions:

$$P_{DC} - P_{OUT} < (T_J - T_L) / R_{TH}$$

where:

- P_{DC} = $I_{DS} * V_{DS}$ (W)
- P_{OUT} = RF Output Power (W)
- T_J = Junction Temperature (°C)
- T_L = Lead Temperature (pin 4) (°C)
- R_{TH} = Thermal Resistance (°C/W)

Parameter	Symbol	Value	Unit
Drain Current	I_{DS}	I_{DSS}	mA
Forward Gate Current	I_{GSF}	0.3	mA
Reverse Gate Current	I_{GSR}	0.3	mA
Drain-to-Source Voltage	V_{DS}	+7	V
Gate-to-Drain Voltage	V_{GD}	-8	V
Gate-to-Source Voltage	V_{GS}	<-5 or >0	V
RF Input Power	P_{IN}	100	mW
Operating Temperature	T_{OP}	-40 to +85	°C
Storage Temperature Range	T_{stor}	-40 to +150	°C
Power Dissipation	P_{DISS}	600	mW
Channel Temperature	T_J	+150	°C

Noise parameters, at typical operating frequencies

Bias $V_{DS}=3.0V, I_{DS}=20mA$

FREQ GHz	FMIN dB	G _{OPT}	G _{OPT} ANG	r_N W	G _A dB
1.0	0.28	0.74	17	0.22	23.1
2.0	0.44	0.69	31	0.18	17.8
4.0	0.54	0.54	84	0.09	13.9
6.0	0.70	0.28	179	0.05	12.2

Bias $V_{DS}=5.0V, I_{DS}=40mA$

FREQ GHz	FMIN dB	G _{OPT}	G _{OPT} ANG	r_N W	G _A dB
1.0	0.34	0.76	19	0.27	23.9
2.0	0.55	0.67	36	0.23	19.1
4.0	0.75	0.47	93	0.11	15.0
6.0	1.04	0.31	-170	0.06	12.9

Scattering Parameters:
Typical S-parameters $V_{DS}=3.0V, I_{DS}=20\text{ mA}$

Freq GHz	S11	S11 Ang	S21	S21 Ang	S12	S12 Ang	S22	S22 Ang
0.5	0.97	-17.5	8.07	162.9	0.01	55.5	0.66	-10.0
1.0	0.92	-34.2	7.76	146.1	0.03	72.8	0.64	-18.9
1.5	0.85	-50.9	7.40	130.4	0.04	62.9	0.61	-27.5
2.0	0.76	-69.2	7.06	114.9	0.05	52.7	0.57	-36.6
2.5	0.67	-89.6	6.67	99.4	0.06	45.3	0.51	-46.7
3.0	0.58	-109.6	6.16	85.3	0.06	39.6	0.47	-55.4
3.5	0.51	-128.5	5.64	72.4	0.07	33.2	0.44	-62.2
4.0	0.46	-146.4	5.16	60.5	0.08	27.3	0.42	-68.0
4.5	0.42	-165.0	4.74	49.3	0.08	23.0	0.39	-73.9
5.0	0.40	175.1	4.37	38.2	0.09	18.9	0.36	-81.1
5.5	0.41	155.0	4.04	27.3	0.09	14.6	0.32	-90.9
6.0	0.44	137.1	3.71	16.7	0.10	9.5	0.29	-102.9
6.5	0.48	123.1	3.43	6.6	0.10	5.3	0.26	-115.7
7.0	0.51	111.6	3.18	-2.9	0.10	1.2	0.23	-128.5
7.5	0.54	101.5	2.96	-11.9	0.11	-2.1	0.21	-141.7
8.0	0.57	91.8	2.75	-21.0	0.11	-5.6	0.20	-156.2
8.5	0.60	83.7	2.55	-29.5	0.12	-9.3	0.19	-170.9
9.0	0.63	77.5	2.40	-37.4	0.12	-13.0	0.20	172.1
9.5	0.66	71.4	2.26	-45.8	0.13	-17.5	0.22	154.7
10.0	0.69	66.3	2.13	-54.0	0.14	-22.1	0.24	140.5
10.5	0.70	61.1	2.02	-62.0	0.14	-26.8	0.27	128.5
11.0	0.71	55.7	1.92	-69.9	0.15	-30.9	0.29	119.0
11.5	0.72	50.1	1.81	-77.4	0.15	-35.0	0.31	109.5
12.0	0.75	45.0	1.70	-84.6	0.16	-39.7	0.33	99.8
12.5	0.76	40.3	1.60	-91.7	0.16	-44.1	0.35	90.3
13.0	0.77	36.4	1.51	-98.6	0.16	-47.5	0.39	81.2
13.5	0.77	32.9	1.47	-106.0	0.17	-51.7	0.43	75.0

Note : De-embedded to device pins

Scattering Parameters:

Typical S-parameters $V_{DS}=5.0V, I_{DS}=40\text{ mA}$

Freq GHz	S11	S11 Ang	S21	S21 Ang	S12	S12 Ang	S22	S22 Ang
0.5	0.97	-18.2	8.87	162.0	0.01	92.8	0.68	-9.5
1.0	0.91	-35.9	8.47	144.6	0.02	66.4	0.67	-18.1
1.5	0.83	-53.3	8.00	128.4	0.03	60.3	0.64	-26.2
2.0	0.74	-72.2	7.54	112.6	0.04	54.0	0.60	-34.5
2.5	0.64	-92.9	7.06	97.1	0.05	46.6	0.55	-43.3
3.0	0.55	-113.4	6.46	83.2	0.06	40.7	0.51	-50.9
3.5	0.48	-132.3	5.87	70.5	0.06	35.9	0.48	-57.2
4.0	0.43	-150.3	5.35	58.8	0.07	31.9	0.46	-62.6
4.5	0.39	-169.1	4.89	47.9	0.07	27.9	0.44	-68.1
5.0	0.37	170.9	4.50	37.0	0.08	25.5	0.42	-75.1
5.5	0.39	151.2	4.16	26.3	0.08	22.1	0.38	-84.3
6.0	0.43	134.3	3.83	15.9	0.09	17.2	0.35	-95.0
6.5	0.47	121.0	3.54	6.0	0.09	13.3	0.32	-106.2
7.0	0.50	110.1	3.29	-3.6	0.10	9.6	0.30	-117.6
7.5	0.53	100.4	3.07	-12.7	0.10	5.7	0.28	-129.3
8.0	0.56	91.3	2.86	-21.8	0.11	2.4	0.26	-141.5
8.5	0.59	83.3	2.66	-30.2	0.12	-0.8	0.25	-154.6
9.0	0.63	77.2	2.52	-38.3	0.13	-4.6	0.26	-170.3
9.5	0.66	71.5	2.38	-46.8	0.13	-9.5	0.27	172.9
10.0	0.69	66.6	2.24	-55.1	0.14	-14.2	0.29	157.4
10.5	0.70	61.3	2.12	-63.3	0.15	-19.5	0.31	144.0
11.0	0.71	55.7	2.01	-71.4	0.15	-24.4	0.33	133.5
11.5	0.73	50.2	1.90	-79.0	0.16	-29.2	0.35	123.1
12.0	0.75	45.0	1.78	-86.4	0.16	-33.8	0.36	112.6
12.5	0.77	40.3	1.67	-93.7	0.17	-37.9	0.38	102.0
13.0	0.77	36.3	1.58	-100.9	0.17	-42.2	0.42	91.7
13.5	0.78	32.7	1.53	-108.4	0.18	-46.7	0.46	83.7

Note : De-embedded to device pins



Caution: ESD sensitive

Appropriate precautions in handling, packaging and testing devices must be observed.

Part Number Ordering Information

Part Number	Reel Size	Devices/Reel
SPF-2086TK	7"	1000

Part Symbolization

The part will be symbolized with the "P2T" designator and a dot signifying pin 1 on the top surface of the package.

PCB Pad Layout

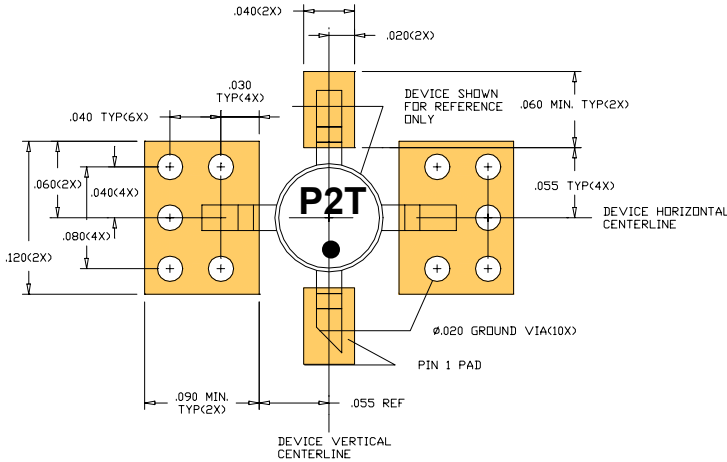

Pin Designation	
1	Gate
2	Source
3	Drain
4	Source

Package Dimensions

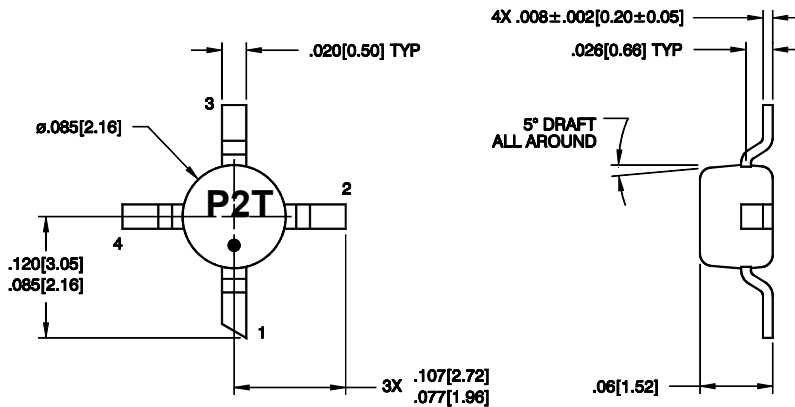

Looking for pricing, stock, or lifecycle information?

Click below to explore more details on WIN SOURCE:

- ⊖ [View SPF-2086TK on WIN SOURCE](#)
- ⊖ [RF Micro Devices Information](#)

Optimize Your Supply Chain with WIN SOURCE Solutions

- ✓ Global Sourcing Solution
- ✓ Obsolete Management
- ✓ Cost Control Management
- ✓ Shortage Management
- ✓ Alternative Solution
- ✓ Excess Inventory Management