



# THE DATASHEET OF STFI24N60M2



N-channel 600 V, 0.168  $\Omega$  typ., 18 A MDmesh II Plus™ low  $Q_g$  Power MOSFETs in TO-220FP, I<sup>2</sup>PAKFP and TO-3PF packages

Datasheet – production data

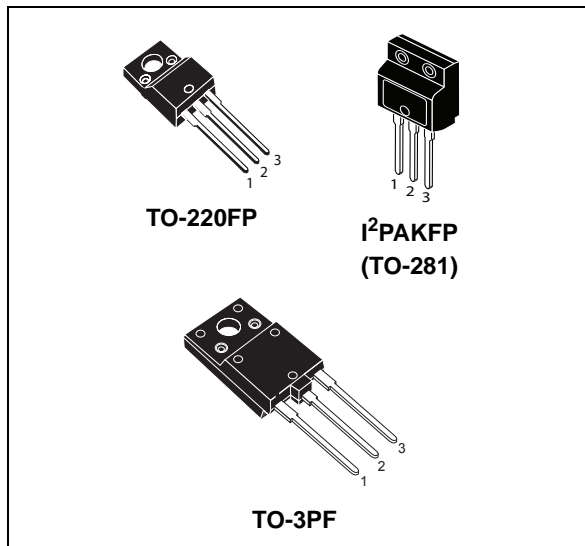
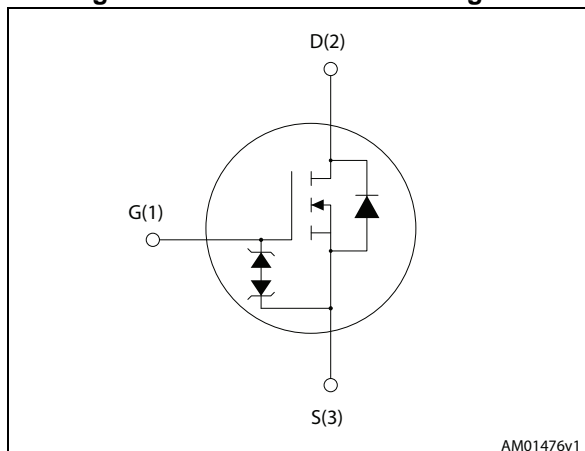

Figure 1. Internal schematic diagram



## Features

Order codes	$V_{DS} @ T_{Jmax}$	$R_{DS(on) max}$	$I_D$
STF24N60M2	650 V	0.19 $\Omega$	18 A
STFI24N60M2			
STFW24N60M2			

- Extremely low gate charge
- Lower  $R_{DS(on)}$  x area vs previous generation
- Low gate input resistance
- 100% avalanche tested
- Zener-protected

## Applications

- Switching applications
- LLC converters, resonant converters

## Description

These devices are N-channel Power MOSFETs developed using a new generation of MDmesh™ technology: MDmesh II Plus™ low  $Q_g$ . These revolutionary Power MOSFETs associate a vertical structure to the company's strip layout to yield one of the world's lowest on-resistance and gate charge. They are therefore suitable for the most demanding high efficiency converters.

Table 1. Device summary

Order codes	Marking	Package	Packaging
STF24N60M2	24N60M2	TO-220FP	Tube
STFI24N60M2		I <sup>2</sup> PAKFP (TO-281)	
STFW24N60M2		TO-3PF	

# Contents

- 1      Electrical ratings ..... 3**
- 2      Electrical characteristics ..... 4**
  - 2.1    Electrical characteristics (curves) ..... 6
- 3      Test circuits ..... 10**
- 4      Package mechanical data ..... 11**
  - 4.1    TO-220FP, STF24N60M2 ..... 12
  - 4.2    I2PAKFP, STFI24N60M2 ..... 14
  - 4.3    TO-3PF, STFW24N60M2 ..... 16
- 5      Revision history ..... 18**

# 1 Electrical ratings

**Table 2. Absolute maximum ratings**

Symbol	Parameter	Value		Unit
		TO-220FP, I <sup>2</sup> PAKFP	TO-3PF	
V <sub>GS</sub>	Gate-source voltage	± 25		V
I <sub>D</sub>	Drain current (continuous) at T <sub>C</sub> = 25 °C	18 <sup>(1)</sup>		A
I <sub>D</sub>	Drain current (continuous) at T <sub>C</sub> = 100 °C	12 <sup>(1)</sup>		A
I <sub>DM</sub> <sup>(2)</sup>	Drain current (pulsed)	72 <sup>(1)</sup>		A
P <sub>TOT</sub>	Total dissipation at T <sub>C</sub> = 25 °C	30	48	W
dv/dt <sup>(3)</sup>	Peak diode recovery voltage slope	15		V/ns
dv/dt <sup>(4)</sup>	MOSFET dv/dt ruggedness	50		V/ns
V <sub>ISO</sub>	Insulation withstand voltage (RMS) from all three leads to external heat sink (t = 1 s; T <sub>C</sub> = 25 °C)	2500	3500	V
T <sub>stg</sub>	Storage temperature	- 55 to 150		°C
T <sub>j</sub>	Max. operating junction temperature			

1. Limited by maximum junction temperature.
2. Pulse width limited by safe operating area.
3. I<sub>SD</sub> ≤ 18 A, di/dt ≤ 400 A/μs; V<sub>DS peak</sub> < V<sub>(BR)DSS</sub>; V<sub>DD</sub> = 400 V.
4. V<sub>DS</sub> ≤ 480 V

**Table 3. Thermal data**

Symbol	Parameter	Value		Unit
		TO-220FP, I <sup>2</sup> PAKFP	TO-3PF	
R <sub>thj-case</sub>	Thermal resistance junction-case max	4.2	2.6	°C/W
R <sub>thj-amb</sub>	Thermal resistance junction-ambient max	62.5	50	°C/W

**Table 4. Avalanche characteristics**

Symbol	Parameter	Value	Unit
I <sub>AR</sub>	Avalanche current, repetitive or not repetitive (pulse width limited by T <sub>jmax</sub> )	3.5	A
E <sub>AS</sub>	Single pulse avalanche energy (starting T <sub>j</sub> =25°C, I <sub>D</sub> = I <sub>AR</sub> ; V <sub>DD</sub> =50)	180	mJ

## 2 Electrical characteristics

( $T_C = 25\text{ °C}$  unless otherwise specified)

**Table 5. On /off states**

Symbol	Parameter	Test conditions	Min.	Typ.	Max.	Unit
$V_{(BR)DSS}$	Drain-source breakdown voltage	$V_{GS} = 0, I_D = 1\text{ mA}$	600			V
$I_{DSS}$	Zero gate voltage drain current	$V_{GS} = 0, V_{DS} = 600\text{ V}$			1	$\mu\text{A}$
		$V_{GS} = 0, V_{DS} = 600\text{ V}, T_C = 125\text{ °C}$			100	$\mu\text{A}$
$I_{GSS}$	Gate-body leakage current	$V_{DS} = 0, V_{GS} = \pm 25\text{ V}$			$\pm 10$	$\mu\text{A}$
$V_{GS(th)}$	Gate threshold voltage	$V_{DS} = V_{GS}, I_D = 250\text{ }\mu\text{A}$	2	3	4	V
$R_{DS(on)}$	Static drain-source on-resistance	$V_{GS} = 10\text{ V}, I_D = 9\text{ A}$		0.168	0.19	$\Omega$

**Table 6. Dynamic**

Symbol	Parameter	Test conditions	Min.	Typ.	Max.	Unit
$C_{iss}$	Input capacitance	$V_{DS} = 100\text{ V}, f = 1\text{ MHz}, V_{GS} = 0$	-	1060	-	pF
$C_{oss}$	Output capacitance		-	55	-	pF
$C_{rss}$	Reverse transfer capacitance		-	2.2	-	pF
$C_{oss\text{ eq.}}^{(1)}$	Equivalent output capacitance	$V_{DS} = 0\text{ to }480\text{ V}, V_{GS} = 0$	-	258	-	pF
$R_G$	Intrinsic gate resistance	$f = 1\text{ MHz}, I_D = 0$	-	7	-	$\Omega$
$Q_g$	Total gate charge	$V_{DD} = 480\text{ V}, I_D = 18\text{ A}, V_{GS} = 10\text{ V}$ (see <a href="#">Figure 16</a> )	-	29	-	nC
$Q_{gs}$	Gate-source charge		-	6	-	nC
$Q_{gd}$	Gate-drain charge		-	12	-	nC

1.  $C_{oss\text{ eq.}}$  is defined as a constant equivalent capacitance giving the same charging time as  $C_{oss}$  when  $V_{DS}$  increases from 0 to 80%  $V_{DSS}$

Table 7. Switching times

Symbol	Parameter	Test conditions	Min.	Typ.	Max.	Unit
$t_{d(on)}$	Turn-on delay time	$V_{DD} = 300\text{ V}$ , $I_D = 9\text{ A}$ , $R_G = 4.7\ \Omega$ , $V_{GS} = 10\text{ V}$ (see <a href="#">Figure 16</a> and <a href="#">21</a> )	-	14	-	ns
$t_r$	Rise time		-	9	-	ns
$t_{d(off)}$	Turn-off delay time		-	60	-	ns
$t_f$	Fall time		-	15	-	ns

Table 8. Source drain diode

Symbol	Parameter	Test conditions	Min.	Typ.	Max.	Unit
$I_{SD}^{(1)}$	Source-drain current		-		18	A
$I_{SDM}^{(1),(2)}$	Source-drain current (pulsed)		-		72	A
$V_{SD}^{(3)}$	Forward on voltage	$I_{SD} = 18\text{ A}$ , $V_{GS} = 0$	-		1.6	V
$t_{rr}$	Reverse recovery time	$I_{SD} = 18\text{ A}$ , $di/dt = 100\text{ A}/\mu\text{s}$ $V_{DD} = 60\text{ V}$ (see <a href="#">Figure 18</a> )	-	332		ns
$Q_{rr}$	Reverse recovery charge		-	4		$\mu\text{C}$
$I_{RRM}$	Reverse recovery current		-	24		A
$t_{rr}$	Reverse recovery time	$I_{SD} = 18\text{ A}$ , $di/dt = 100\text{ A}/\mu\text{s}$ $V_{DD} = 60\text{ V}$ , $T_j = 150\text{ }^\circ\text{C}$ (see <a href="#">Figure 18</a> )	-	450		ns
$Q_{rr}$	Reverse recovery charge		-	5.5		$\mu\text{C}$
$I_{RRM}$	Reverse recovery current		-	25		A

1. The value is rated according to  $R_{thj-case}$  and limited by package.
2. Pulse width limited by safe operating area
3. Pulsed: pulse duration =  $300\ \mu\text{s}$ , duty cycle 1.5%

## 2.1 Electrical characteristics (curves)

Figure 2. Safe operating area for TO-220FP and I<sup>2</sup>PAKFP

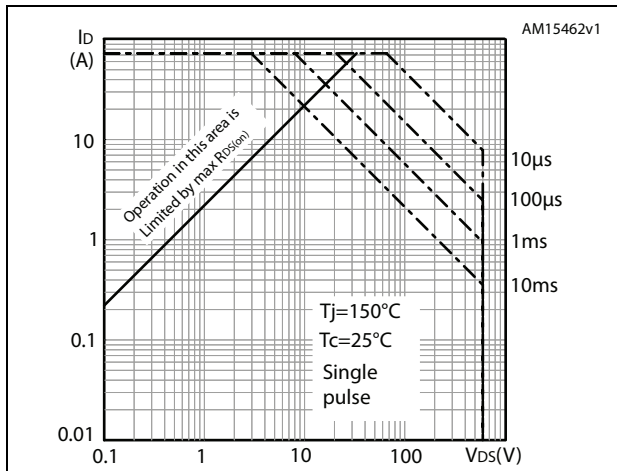

Figure 3. Thermal impedance for TO-220FP and I<sup>2</sup>PAKFP

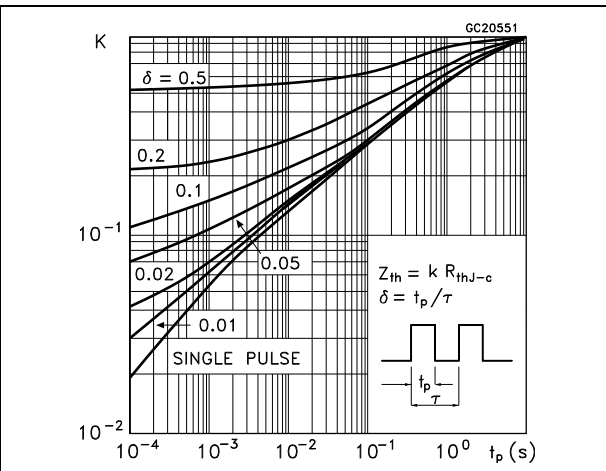

Figure 4. Safe operating area for TO-3PF

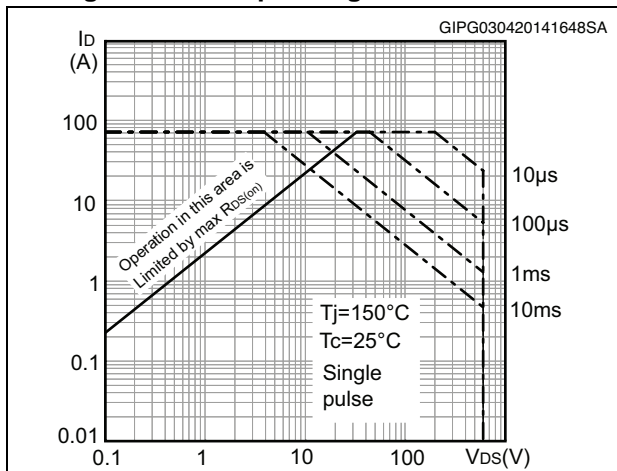

Figure 5. Thermal impedance for TO-3PF

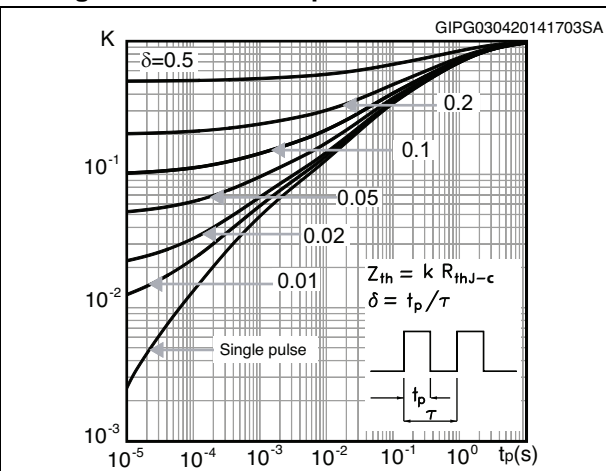

Figure 6. Output characteristics

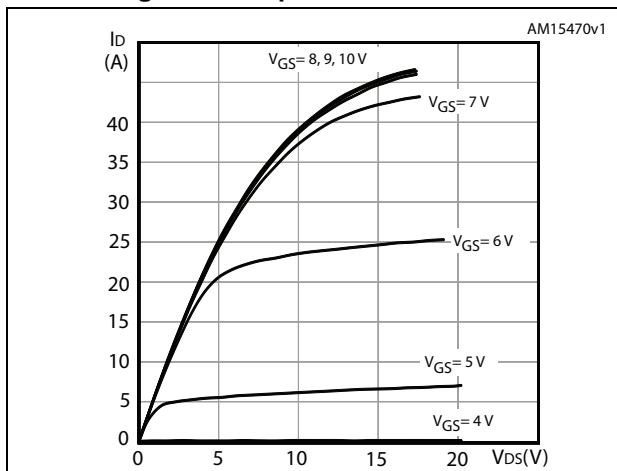

Figure 7. Transfer characteristics

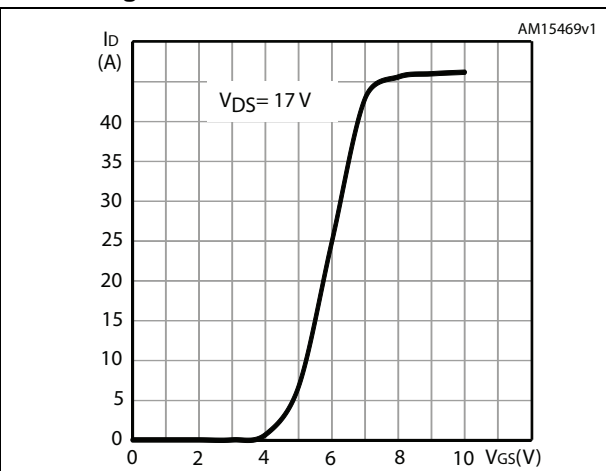

Figure 8. Gate charge vs gate-source voltage

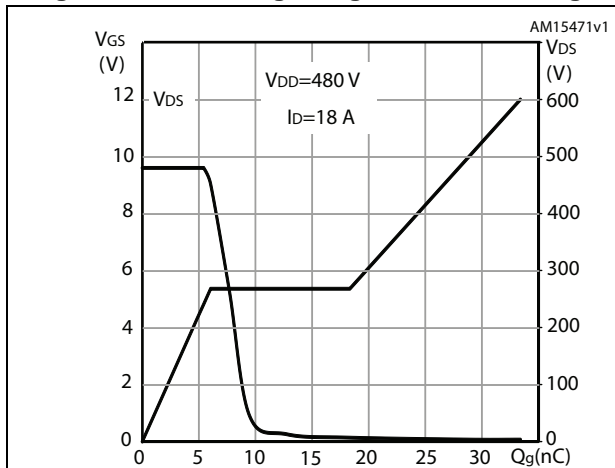

Figure 9. Static drain-source on-resistance

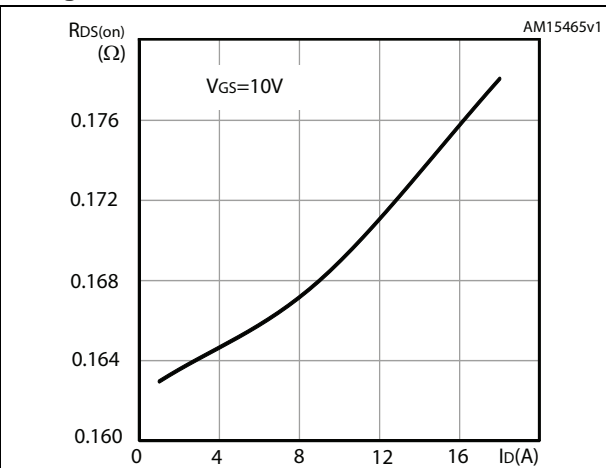

Figure 10. Capacitance variations

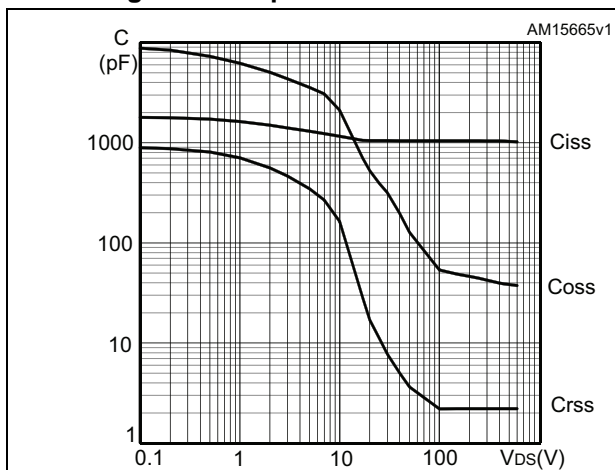

Figure 11. Output capacitance stored energy

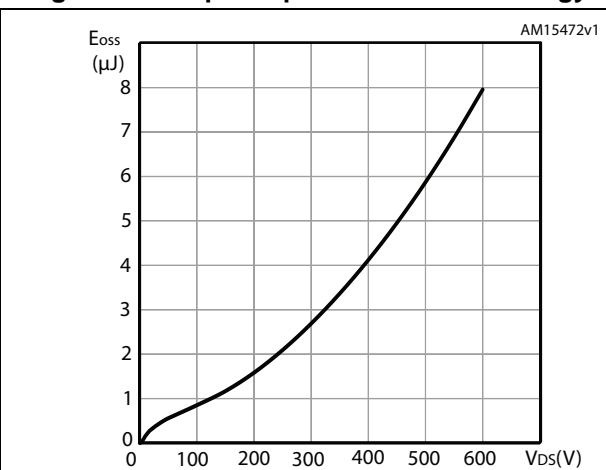

Figure 12. Normalized gate threshold voltage vs temperature

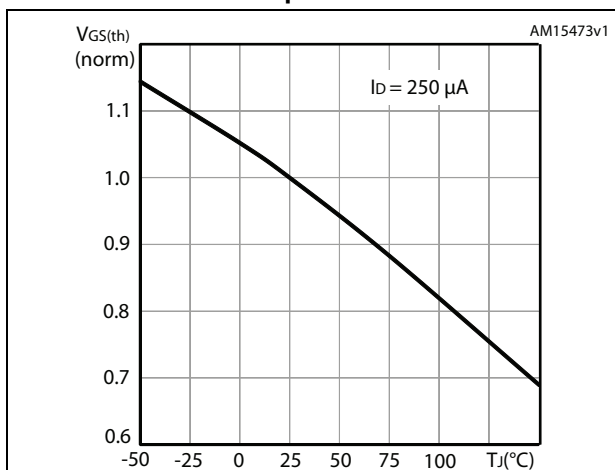

Figure 13. Normalized on-resistance vs temperature

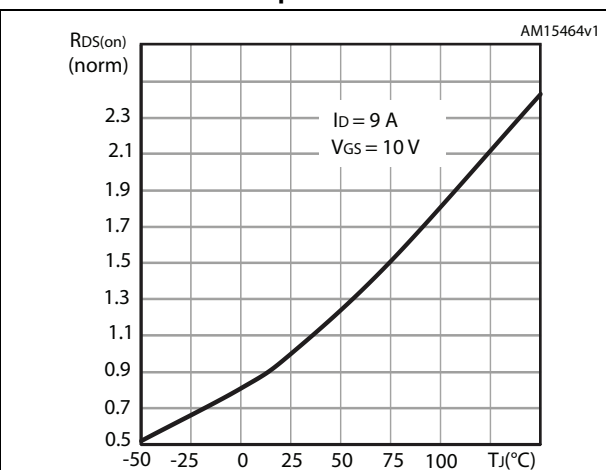

Figure 14. Source-drain diode forward characteristics

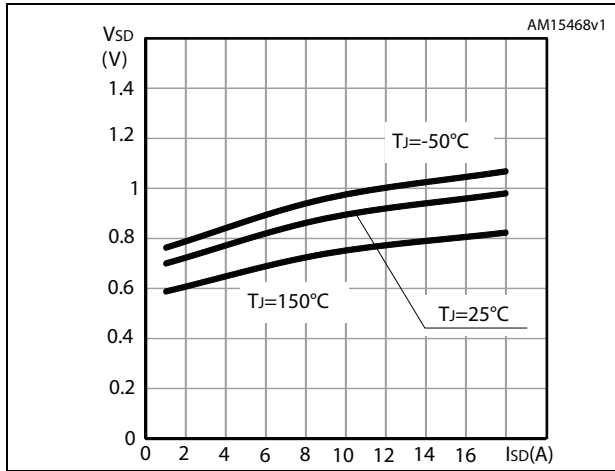
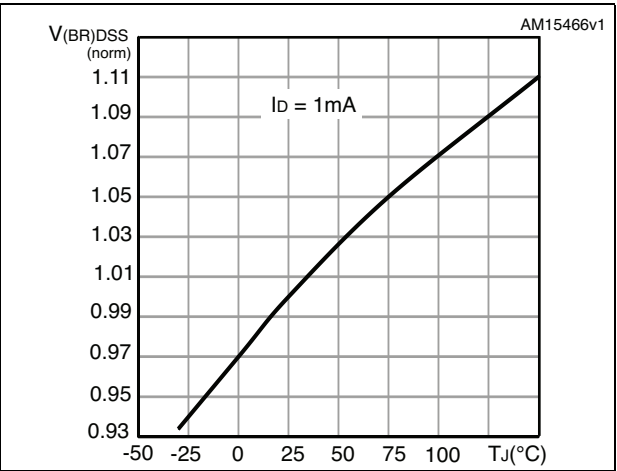

Figure 15. Normalized V<sub>(BR)DSS</sub> vs temperature



### 3 Test circuits

Figure 16. Switching times test circuit for resistive load

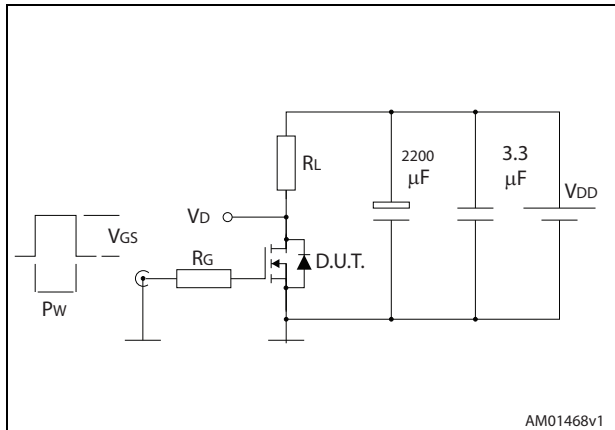

Figure 17. Gate charge test circuit

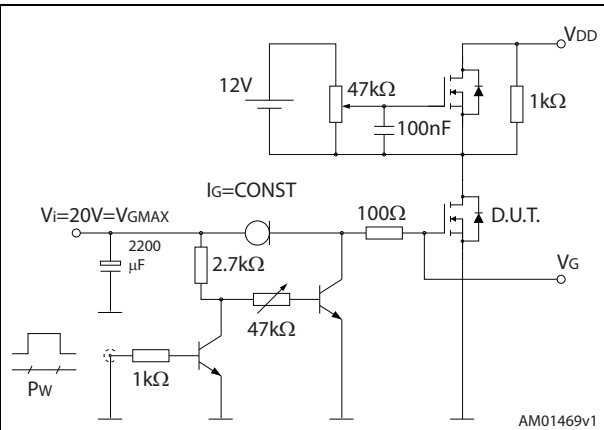

Figure 18. Test circuit for inductive load switching and diode recovery times

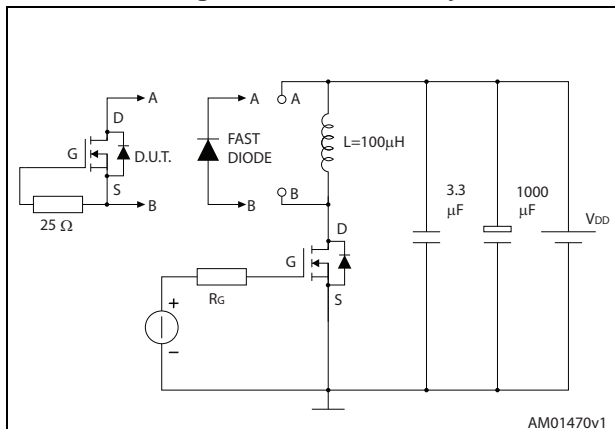

Figure 19. Unclamped inductive load test circuit

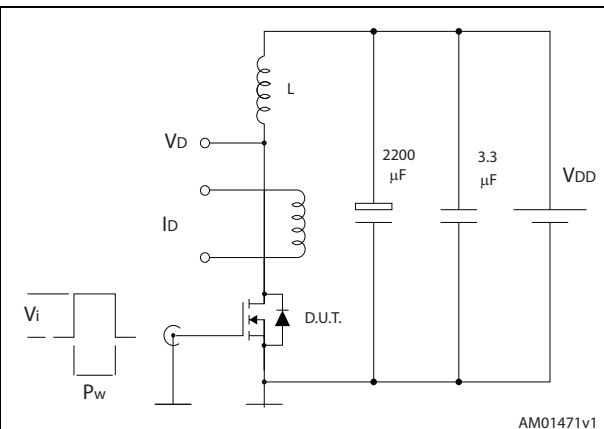

Figure 20. Unclamped inductive waveform

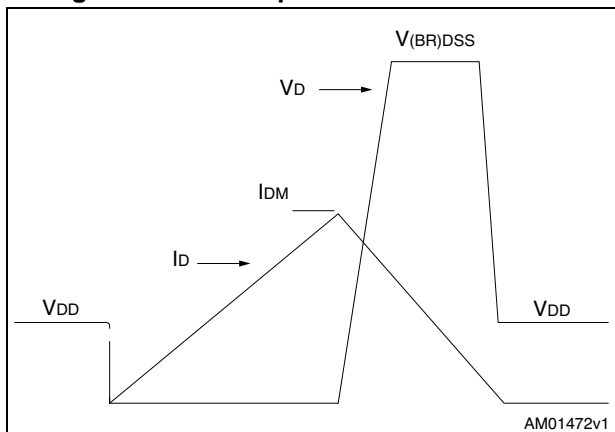
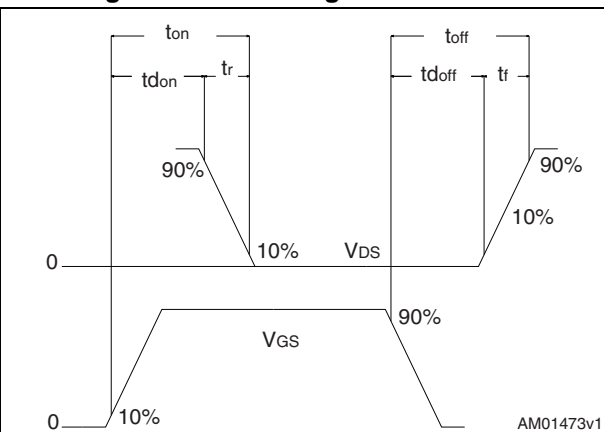

Figure 21. Switching time waveform



## 4 Package mechanical data

In order to meet environmental requirements, ST offers these devices in different grades of ECOPACK<sup>®</sup> packages, depending on their level of environmental compliance. ECOPACK<sup>®</sup> specifications, grade definitions and product status are available at: [www.st.com](http://www.st.com). ECOPACK<sup>®</sup> is an ST trademark.

### 4.1 TO-220FP, STF24N60M2

Figure 22. TO-220FP drawing

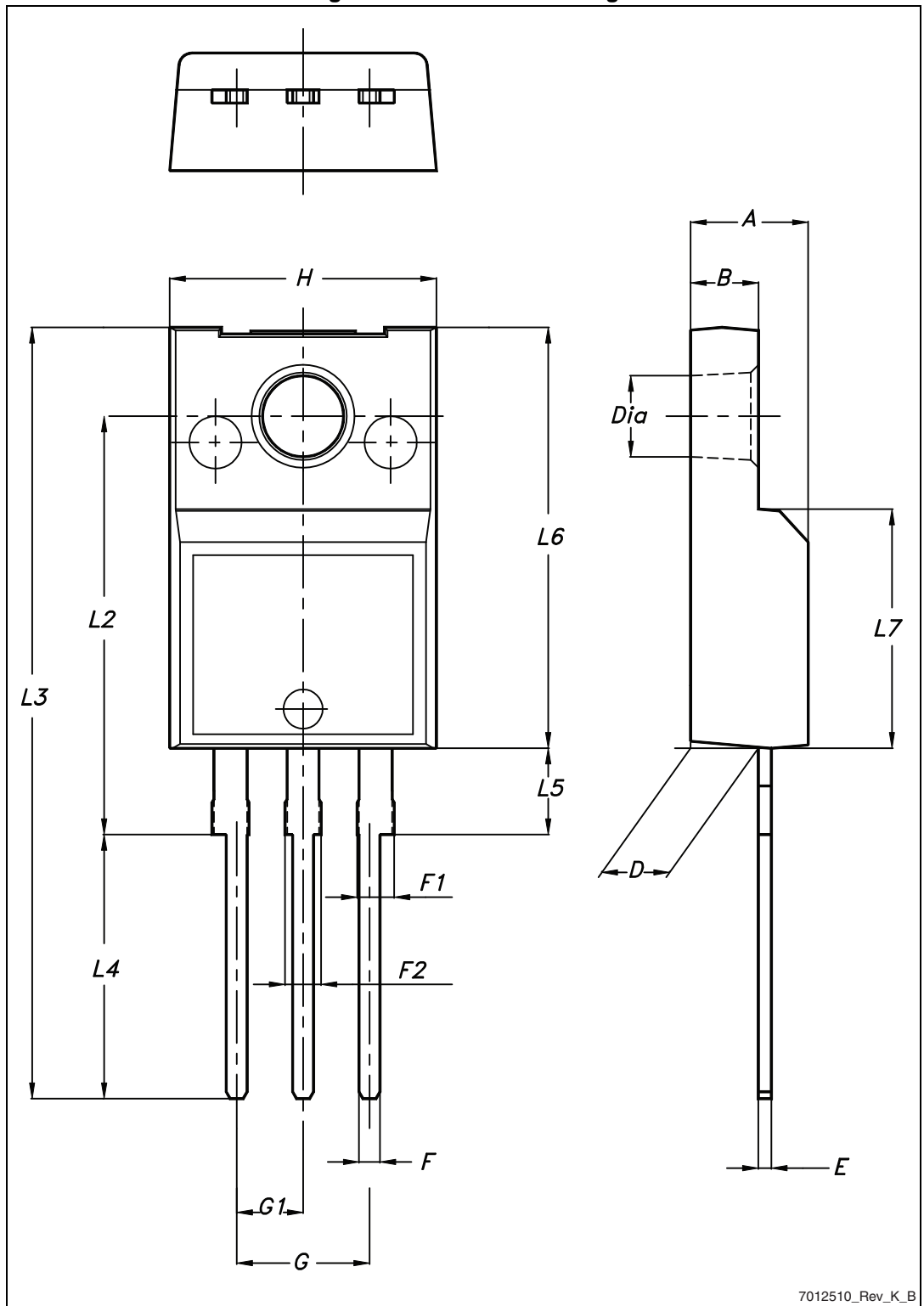

7012510\_Rev\_K\_B

Table 9. TO-220FP mechanical data

Dim.	mm		
	Min.	Typ.	Max.
A	4.4		4.6
B	2.5		2.7
D	2.5		2.75
E	0.45		0.7
F	0.75		1
F1	1.15		1.70
F2	1.15		1.70
G	4.95		5.2
G1	2.4		2.7
H	10		10.4
L2		16	
L3	28.6		30.6
L4	9.8		10.6
L5	2.9		3.6
L6	15.9		16.4
L7	9		9.3
Dia	3		3.2

### 4.2 I<sup>2</sup>PAKFP, STFI24N60M2

Figure 23. I<sup>2</sup>PAKFP (TO-281) drawing

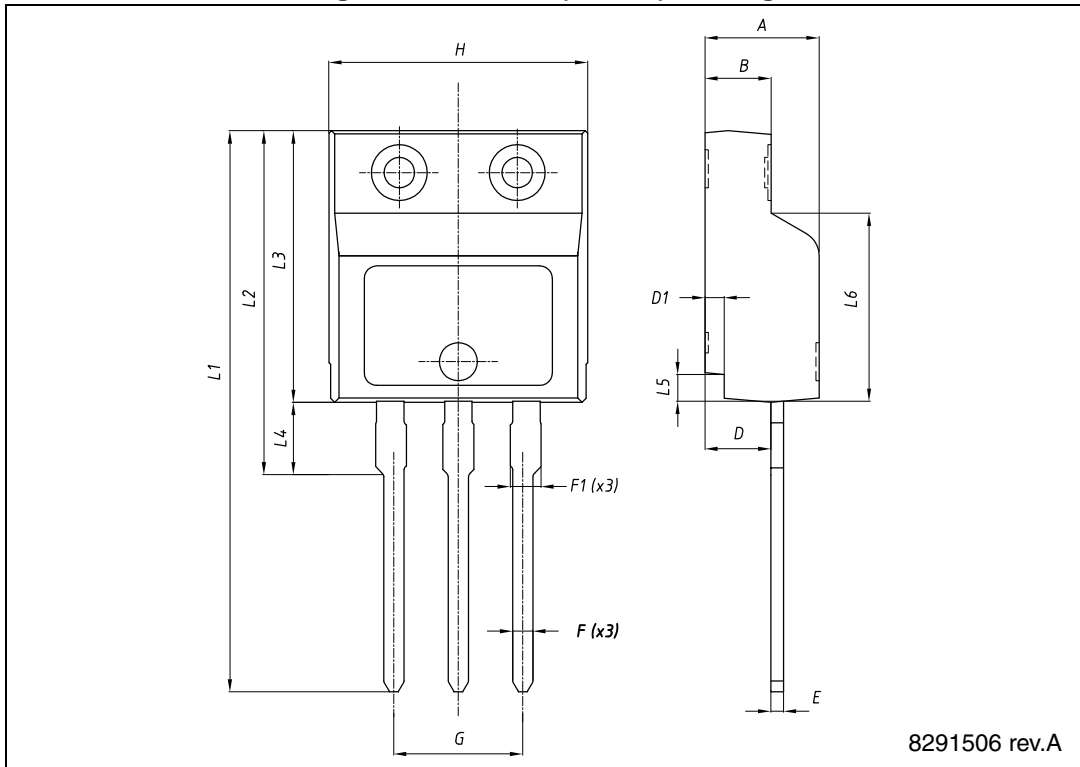
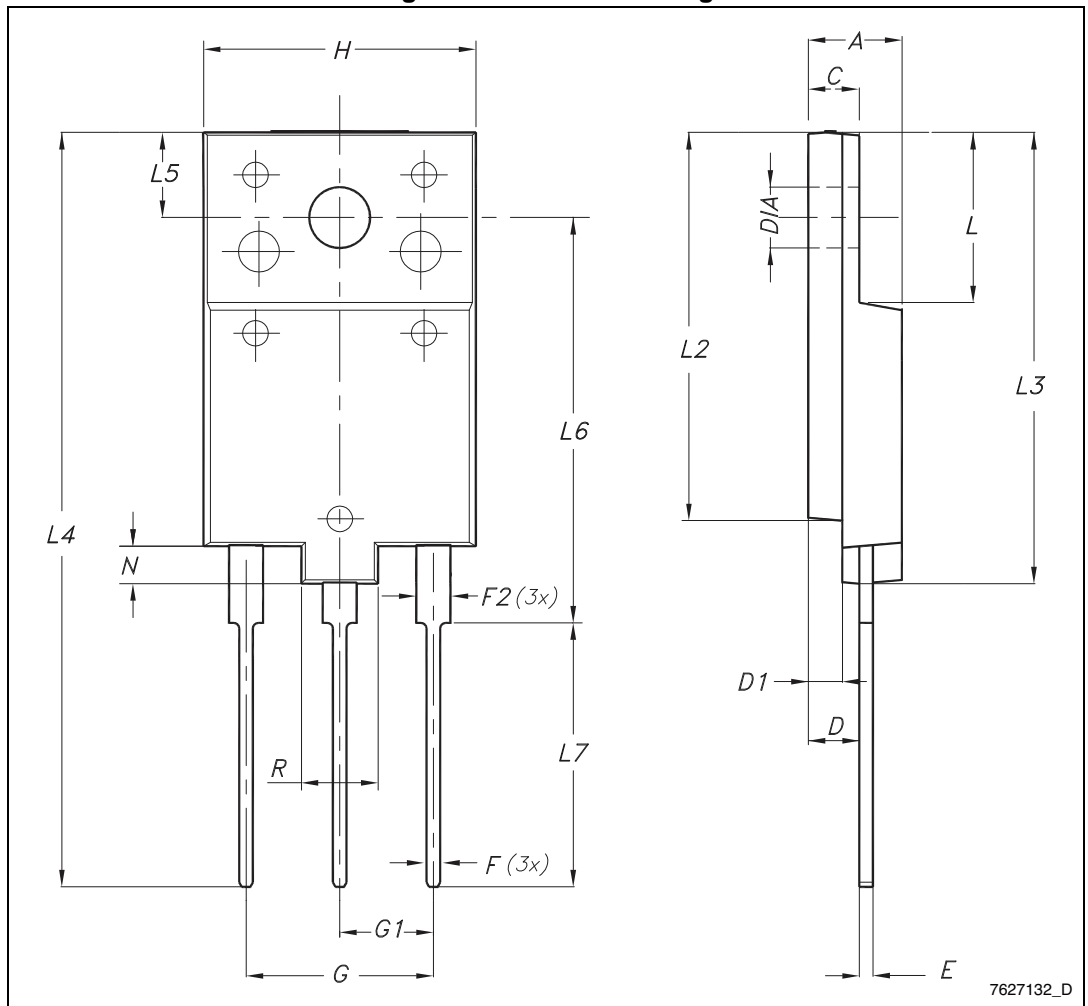

Table 10. I<sup>2</sup>PAKFP (TO-281) mechanical data

Dim.	mm		
	Min.	Typ.	Max.
A	4.40	-	4.60
B	2.50		2.70
D	2.50		2.75
D1	0.65		0.85
E	0.45		0.70
F	0.75		1.00
F1			1.20
G	4.95		5.20
H	10.00		10.40
L1	21.00		23.00
L2	13.20		14.10
L3	10.55		10.85
L4	2.70		3.20
L5	0.85		1.25
L6	7.30		7.50

### 4.3 TO-3PF, STFW24N60M2

Figure 24. TO-3PF drawing



7627132\_D

Table 11. TO-3PF mechanical data

Dim.	mm		
	Min.	Typ.	Max.
A	5.30		5.70
C	2.80		3.20
D	3.10		3.50
D1	1.80		2.20
E	0.80		1.10
F	0.65		0.95
F2	1.80		2.20
G	10.30		11.50
G1		5.45	
H	15.30		15.70
L	9.80	10	10.20
L2	22.80		23.20
L3	26.30		26.70
L4	43.20		44.40
L5	4.30		4.70
L6	24.30		24.70
L7	14.60		15
N	1.80		2.20
R	3.80		4.20
Dia	3.40		3.80

## 5 Revision history

Table 12. Document revision history

Date	Revision	Changes
10-Dec-2012	1	First release.
20-Dec-2012	2	Added MOSFET dv/dt ruggedness in <a href="#">Table 2: Absolute maximum ratings</a> .
14-Jan-2013	3	Modified: <a href="#">Figure 16, 17</a>
28-May-2013	4	<ul style="list-style-type: none"> <li>– Modified: <a href="#">Figure 16, 17, 18</a> and <a href="#">19</a></li> <li>– Minor text changes</li> </ul>
28-Feb-2014	5	<ul style="list-style-type: none"> <li>– Modified: <math>R_{thj-case}</math> value in <a href="#">Table 3</a></li> <li>– Modified: <a href="#">Figure 12</a></li> <li>– Minor text changes</li> </ul>
07-Apr-2014	6	<ul style="list-style-type: none"> <li>– Added: TO-3PF package</li> <li>– Added: <a href="#">Section 4.3: TO-3PF, STF24N60M2</a></li> <li>– Minor text changes</li> </ul>

**Please Read Carefully:**

Information in this document is provided solely in connection with ST products. STMicroelectronics NV and its subsidiaries ("ST") reserve the right to make changes, corrections, modifications or improvements, to this document, and the products and services described herein at any time, without notice.

All ST products are sold pursuant to ST's terms and conditions of sale.

Purchasers are solely responsible for the choice, selection and use of the ST products and services described herein, and ST assumes no liability whatsoever relating to the choice, selection or use of the ST products and services described herein.

No license, express or implied, by estoppel or otherwise, to any intellectual property rights is granted under this document. If any part of this document refers to any third party products or services it shall not be deemed a license grant by ST for the use of such third party products or services, or any intellectual property contained therein or considered as a warranty covering the use in any manner whatsoever of such third party products or services or any intellectual property contained therein.

**UNLESS OTHERWISE SET FORTH IN ST'S TERMS AND CONDITIONS OF SALE ST DISCLAIMS ANY EXPRESS OR IMPLIED WARRANTY WITH RESPECT TO THE USE AND/OR SALE OF ST PRODUCTS INCLUDING WITHOUT LIMITATION IMPLIED WARRANTIES OF MERCHANTABILITY, FITNESS FOR A PARTICULAR PURPOSE (AND THEIR EQUIVALENTS UNDER THE LAWS OF ANY JURISDICTION), OR INFRINGEMENT OF ANY PATENT, COPYRIGHT OR OTHER INTELLECTUAL PROPERTY RIGHT.**

**ST PRODUCTS ARE NOT DESIGNED OR AUTHORIZED FOR USE IN: (A) SAFETY CRITICAL APPLICATIONS SUCH AS LIFE SUPPORTING, ACTIVE IMPLANTED DEVICES OR SYSTEMS WITH PRODUCT FUNCTIONAL SAFETY REQUIREMENTS; (B) AERONAUTIC APPLICATIONS; (C) AUTOMOTIVE APPLICATIONS OR ENVIRONMENTS, AND/OR (D) AEROSPACE APPLICATIONS OR ENVIRONMENTS. WHERE ST PRODUCTS ARE NOT DESIGNED FOR SUCH USE, THE PURCHASER SHALL USE PRODUCTS AT PURCHASER'S SOLE RISK, EVEN IF ST HAS BEEN INFORMED IN WRITING OF SUCH USAGE, UNLESS A PRODUCT IS EXPRESSLY DESIGNATED BY ST AS BEING INTENDED FOR "AUTOMOTIVE, AUTOMOTIVE SAFETY OR MEDICAL" INDUSTRY DOMAINS ACCORDING TO ST PRODUCT DESIGN SPECIFICATIONS. PRODUCTS FORMALLY ESCC, QML OR JAN QUALIFIED ARE DEEMED SUITABLE FOR USE IN AEROSPACE BY THE CORRESPONDING GOVERNMENTAL AGENCY.**

Resale of ST products with provisions different from the statements and/or technical features set forth in this document shall immediately void any warranty granted by ST for the ST product or service described herein and shall not create or extend in any manner whatsoever, any liability of ST.

ST and the ST logo are trademarks or registered trademarks of ST in various countries.

Information in this document supersedes and replaces all information previously supplied.

The ST logo is a registered trademark of STMicroelectronics. All other names are the property of their respective owners.

© 2014 STMicroelectronics - All rights reserved



STMicroelectronics group of companies

Australia - Belgium - Brazil - Canada - China - Czech Republic - Finland - France - Germany - Hong Kong - India - Israel - Italy - Japan - Malaysia - Malta - Morocco - Philippines - Singapore - Spain - Sweden - Switzerland - United Kingdom - United States of America

[www.st.com](http://www.st.com)

## Looking for pricing, stock, or lifecycle information?

Click below to explore more details on WIN SOURCE:

-  [View STFI24N60M2 on WIN SOURCE](#)
-  [STMicroelectronics Information](#)

## Optimize Your Supply Chain with WIN SOURCE Solutions

-  Global Sourcing Solution
-  Obsolete Management
-  Cost Control Management
-  Shortage Management
-  Alternative Solution
-  Excess Inventory Management