



THE DATASHEET OF LMV981BLX



LMV98x-N Small, Low-Power, 1.8-V RRIO Operational Amplifiers With Shutdown

1 Features

- Ensured 1.8-V, 2.7-V, and 5-V Specifications
- Output Swing:
 - 600-Ω Load: 80-mV from Rail
 - 2-kΩ Load: 30-mV from Rail
- V_{CM} 200 mV Beyond Rails
- Supply Current (Per Channel): 100 μA
- Gain Bandwidth Product: 1.4 MHz
- Maximum V_{OS} : 4 mV
- Gain with 600-Ω Load: 101 dB
- Ultra-Small Package: DSBGA 1.0 mm × 1.5 mm
- Turnon Time from Shutdown: 19 μs
- Independent Shutdown on Dual
- Temperature Range: -40°C to 125°C

2 Applications

- Industrial and Automotive
- Consumer Communication
- Fitness Trackers
- Wearables
- Mobile Phones
- Portable Audio
- Portable and Battery-Powered Electronic Equipment
- Supply Current Monitoring
- Battery Monitoring

3 Description

LMV98x-N are low-voltage, low-power operational amplifiers. LMV98x-N operate from 1.8-V to 5-V supply voltages and have rail-to-rail input and output. LMV98x-N input common mode voltage extends 200mV beyond the supplies which enables user enhanced functionality beyond the supply voltage range. The output can swing rail-to-rail unloaded and within 105 mV from the rail with 600-Ω load at 1.8-V supply. LMV98x-N are optimized to work at 1.8 V, which makes them ideal for portable two-cell battery powered systems and single cell Li-Ion systems.

LMV98x-N offer a shutdown pin that can be used to disable the device and reduce the supply current. The device is in shutdown when the \overline{SHDN} pin is low. The output is high impedance in shutdown.

LMV98x-N exhibit excellent speed-power ratio, achieving 1.4-MHz gain bandwidth product at 1.8-V supply voltage with low supply current. LMV98x-N are capable of driving a 600-Ω load and up to 1000-pF capacitive load with minimal ringing. LMV98x-N have a high DC gain of 101 dB, making them suitable for low frequency applications.

Device Information⁽¹⁾

PART NUMBER	PACKAGE	BODY SIZE (NOM)
LMV981-N	DSBGA (6)	1.50 mm × 1.30 mm
	SC70 (6)	2.00 mm × 1.25 mm
	SOT-23 (6)	2.90 mm × 1.60 mm
LMV982-N	VSSOP (10)	3.00 mm × 3.00 mm

(1) For all available packages, see the orderable addendum at the end of the data sheet.

Typical Application

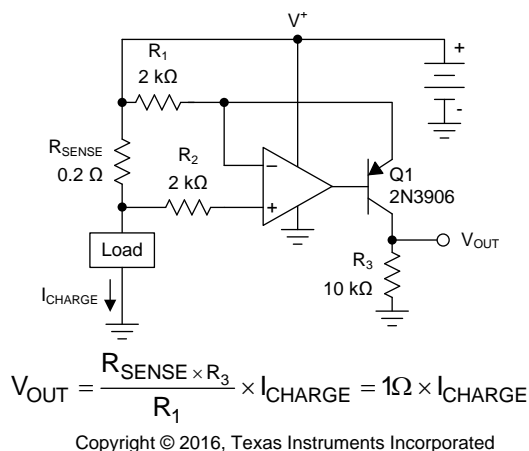

Simplified Schematic

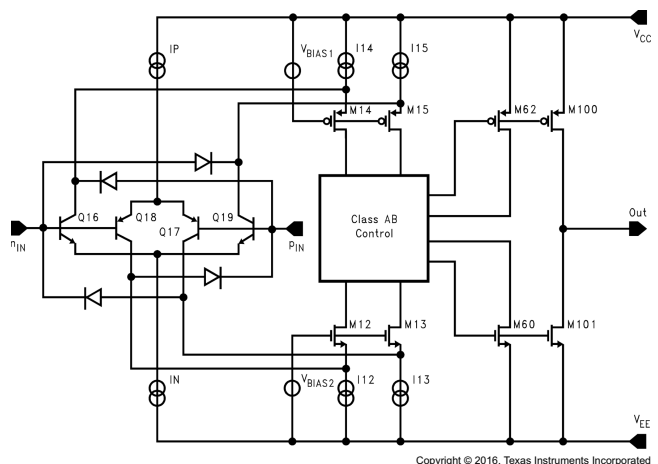

Table of Contents

1 Features	1	8.2 Functional Block Diagram	17
2 Applications	1	8.3 Feature Description	17
3 Description	1	8.4 Device Functional Modes	17
4 Revision History	2	9 Application and Implementation	20
5 Description (continued)	3	9.1 Application Information	20
6 Pin Configuration and Functions	3	9.2 Typical Applications	20
7 Specifications	5	9.3 Do's and Don'ts	23
7.1 Absolute Maximum Ratings	5	10 Power Supply Recommendations	23
7.2 ESD Ratings	5	11 Layout	24
7.3 Recommended Operating Conditions	5	11.1 Layout Guidelines	24
7.4 Thermal Information	5	11.2 Layout Example	24
7.5 Electrical Characteristics – DC, 1.8 V	6	12 Device and Documentation Support	25
7.6 Electrical Characteristics – AC, 1.8 V	7	12.1 Documentation Support	25
7.7 Electrical Characteristics – DC, 2.7 V	8	12.2 Related Links	25
7.8 Electrical Characteristics – AC, 2.7 V	9	12.3 Receiving Notification of Documentation Updates	25
7.9 Electrical Characteristics – DC, 5 V	10	12.4 Community Resources	25
7.10 Electrical Characteristics – AC, 5 V	11	12.5 Trademarks	25
7.11 Typical Characteristics	12	12.6 Electrostatic Discharge Caution	25
8 Detailed Description	17	12.7 Glossary	25
8.1 Overview	17	13 Mechanical, Packaging, and Orderable Information	25

4 Revision History

NOTE: Page numbers for previous revisions may differ from page numbers in the current version.

Changes from Revision L (March 2013) to Revision M	Page
• Added <i>Feature Description</i> section, <i>Device Functional Modes</i> , <i>Application and Implementation</i> section, <i>Power Supply Recommendations</i> section, <i>Layout</i> section, <i>Device and Documentation Support</i> section, and <i>Mechanical, Packaging, and Orderable Information</i> section	1
• Changed $R_{\theta JA}$ values for LMV981-N: YZR (DSBGA) From: 286 To: 138.2	5
• Changed $R_{\theta JA}$ values for LMV981-N: DCK (SC70) From: 286 To: 229.1	5
• Changed $R_{\theta JA}$ values for LMV981-N: DBV (SOT-23) From: 286 To: 209.9	5
• Changed $R_{\theta JA}$ values for LMV982-N: DGS (VSSOP) From: 286 To: 182.8	5

Changes from Revision K (March 2013) to Revision L	Page
• Changed layout of National Semiconductor Data Sheet to TI format	1

5 Description (continued)

LMV981-N is offered in space-saving, 6-pin DSBGA, SC70, and SOT-23 packages. The 6-pin DSBGA package has only a 1.006 mm × 1.514 mm × 0.945 mm footprint. LMV982-N is offered in a space-saving, 10-pin VSSOP package. These small packages are ideal solutions for area constrained PCBs and portable electronics such as cellular phones and PDAs.

6 Pin Configuration and Functions

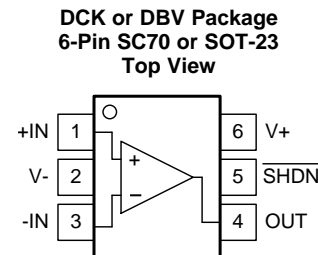
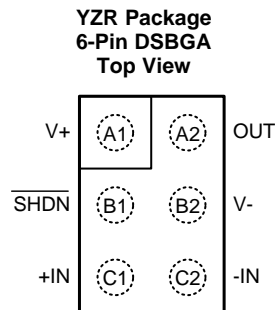

Pin Functions: LMV981-N

NAME	PIN		TYPE ⁽¹⁾	DESCRIPTION
	DSBGA	SC70, SOT-23		
+IN	C1	1	I	Noninverting input
-IN	C2	3	I	Inverting input
OUT	A2	4	O	Output
SHDN	B1	5	I	Shutdown input
V+	A1	6	P	Positive (highest) power supply
V-	B2	2	P	Negative (lowest) power supply

(1) I = Input, O = Output, P = Power

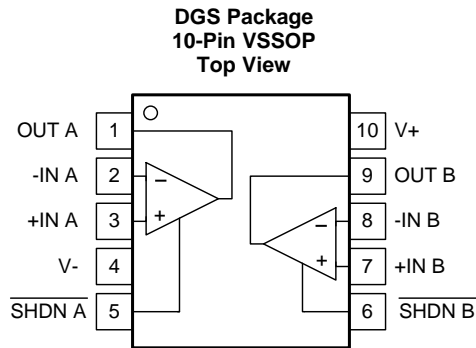
Pin Functions: LMV982-N

PIN		TYPE ⁽¹⁾	DESCRIPTION
NAME	VSSOP		
+IN A	3	I	Noninverting input, channel A
+IN B	7	I	Noninverting input, channel B
-IN A	2	I	Inverting input, channel A
-IN B	8	I	Inverting input, channel B
OUT A	1	O	Output, channel A
OUT B	9	O	Output, channel B
$\overline{\text{SHDN A}}$	5	I	Shutdown input, channel A
$\overline{\text{SHDN B}}$	6	I	Shutdown input, channel B
V+	10	P	Positive (highest) power supply
V-	4	P	Negative (lowest) power supply

(1) I = Input, O = Output, P = Power

7 Specifications

7.1 Absolute Maximum Ratings

over operating free-air temperature range (unless otherwise noted)⁽¹⁾⁽²⁾

	MIN	MAX	UNIT
Supply voltage (V ⁺ – V ⁻)		5.5	V
Differential input voltage	±Supply voltage		
Voltage at input/output pins	V ⁺ + 0.3	V ⁻ - 0.3	V
Junction temperature ⁽³⁾		150	°C
Storage temperature, T _{stg}	-65	150	°C

- (1) Stresses beyond those listed under *Absolute Maximum Ratings* may cause permanent damage to the device. These are stress ratings only, which do not imply functional operation of the device at these or any other conditions beyond those indicated under *Recommended Operating Conditions*. Exposure to absolute-maximum-rated conditions for extended periods may affect device reliability.
- (2) For soldering specifications, see TI application report, [Absolute Maximum Ratings for Soldering](#) (SNOA549).
- (3) The maximum power dissipation is a function of T_{J(MAX)}, R_{θJA}, and T_A. The maximum allowable power dissipation at any ambient temperature is P_D = (T_{J(MAX)} - T_A) / R_{θJA}. All numbers apply for packages soldered directly into a PCB.

7.2 ESD Ratings

		VALUE	UNIT
V _(ESD) Electrostatic discharge	Human-body model (HBM), per ANSI/ESDA/JEDEC JS-001 ⁽¹⁾	±2000	V
	Machine model ⁽²⁾	±200	

- (1) Human Body Model, applicable std. MIL-STD-883, Method 3015.7. JEDEC document JEP155 states that 500-V HBM allows safe manufacturing with a standard ESD control process.
- (2) Machine Model, applicable std. JESD22-A115-A (ESD MM std. of JEDEC)

7.3 Recommended Operating Conditions

over operating free-air temperature range (unless otherwise noted)

	MIN	MAX	UNIT
Supply voltage	1.8	5	V
Temperature	-40	125	°C

7.4 Thermal Information

THERMAL METRIC ⁽¹⁾	LMV981-N			LMV982-N	UNIT
	YZR (DSBGA)	DCK (SC70)	DBV (SOT-23)	DGS (VSSOP)	
	6 PINS	6 PINS	6 PINS	10 PINS	
R _{θJA} Junction-to-ambient thermal resistance	138.2	229.1	209.9	182.8	°C/W
R _{θJC(top)} Junction-to-case (top) thermal resistance	1.2	116.1	181.2	73.1	°C/W
R _{θJB} Junction-to-board thermal resistance	23.4	53.3	53.2	103.3	°C/W
ψ _{JT} Junction-to-top characterization parameter	5	8.8	55.5	12.8	°C/W
ψ _{JB} Junction-to-board characterization parameter	23.2	52.7	52.6	101.9	°C/W

- (1) For more information about traditional and new thermal metrics, see the [Semiconductor and IC Package Thermal Metrics](#) application report.

7.5 Electrical Characteristics – DC, 1.8 V

 $T_J = 25^\circ\text{C}$, $V^+ = 1.8\text{ V}$, $V^- = 0\text{ V}$, $V_{CM} = V^+/2$, $V_O = V^+/2$, $R_L > 1\text{ M}\Omega$, and $\overline{\text{SHDN}}$ tied to V^+ (unless otherwise noted)⁽¹⁾

PARAMETER		TEST CONDITIONS		MIN ⁽²⁾	TYP ⁽³⁾	MAX ⁽²⁾	UNIT	
V_{OS}	Input offset voltage	LMV981-N (single)	$T_J = 25^\circ\text{C}$		1	4	mV	
			$T_J = -40^\circ\text{C}$ to 125°C			6		
		LMV982-N (dual)	$T_J = 25^\circ\text{C}$		1	5.5		
			$T_J = -40^\circ\text{C}$ to 125°C					7.5
TCV_{OS}	Input offset voltage average drift				5.5		$\mu\text{V}/^\circ\text{C}$	
I_B	Input bias current	$T_J = 25^\circ\text{C}$			15	35	nA	
		$T_J = -40^\circ\text{C}$ to 125°C				50		
I_{OS}	Input offset current	$T_J = 25^\circ\text{C}$			13	25	nA	
		$T_J = -40^\circ\text{C}$ to 125°C				40		
I_S	Supply current (per channel)	$T_J = 25^\circ\text{C}$			103	185	μA	
		$T_J = -40^\circ\text{C}$ to 125°C				205		
		In shutdown	LMV981-N (single)	$T_J = 25^\circ\text{C}$		0.156		1
				$T_J = -40^\circ\text{C}$ to 125°C				2
			LMV982-N (dual)	$T_J = 25^\circ\text{C}$		0.178		3.5
$T_J = -40^\circ\text{C}$ to 125°C					5			
CMRR	Common mode rejection ratio	LMV981-N, $0\text{ V} \leq V_{CM} \leq 0.6\text{ V}$, $1.4\text{ V} \leq V_{CM} \leq 1.8\text{ V}$ ⁽⁴⁾		$T_J = 25^\circ\text{C}$	60	78	dB	
				$T_J = -40^\circ\text{C}$ to 125°C		55		
		LMV982, $0\text{ V} \leq V_{CM} \leq 0.6\text{ V}$, $1.4\text{ V} \leq V_{CM} \leq 1.8\text{ V}$ ⁽⁴⁾		$T_J = 25^\circ\text{C}$	55	76		
				$T_J = -40^\circ\text{C}$ to 125°C		50		
		$-0.2\text{ V} \leq V_{CM} \leq 0\text{ V}$, $1.8\text{ V} \leq V_{CM} \leq 2\text{ V}$			50	72		
PSRR	Power supply rejection ratio	$1.8\text{ V} \leq V^+ \leq 5\text{ V}$		$T_J = 25^\circ\text{C}$	75	100	dB	
				$T_J = -40^\circ\text{C}$ to 125°C		70		
CMVR	Input common-mode voltage	For CMRR range $\geq 50\text{ dB}$		$T_A = 25^\circ\text{C}$	$V^- - 0.2$	-0.2	V	
				$T_A = -40^\circ\text{C}$ to 85°C	V^-	V^+		
				$T_A = 125^\circ\text{C}$	$V^- + 0.2$	$V^+ - 0.2$		
A_V	Large signal voltage gain LMV981-N (single)	$R_L = 600\ \Omega$ to 0.9 V , $V_O = 0.2\text{ V}$ to 1.6 V , $V_{CM} = 0.5\text{ V}$		$T_J = 25^\circ\text{C}$	77	101	dB	
				$T_J = -40^\circ\text{C}$ to 125°C		73		
		$R_L = 2\text{ k}\Omega$ to 0.9 V , $V_O = 0.2\text{ V}$ to 1.6 V , $V_{CM} = 0.5\text{ V}$		$T_J = 25^\circ\text{C}$	80	105		
				$T_J = -40^\circ\text{C}$ to 125°C		75		
	Large signal voltage gain LMV982-N (dual)	$R_L = 600\ \Omega$ to 0.9 V , $V_O = 0.2\text{ V}$ to 1.6 V , $V_{CM} = 0.5\text{ V}$		$T_J = 25^\circ\text{C}$	75	90	dB	
				$T_J = -40^\circ\text{C}$ to 125°C		72		
		$R_L = 2\text{ k}\Omega$ to 0.9 V , $V_O = 0.2\text{ V}$ to 1.6 V , $V_{CM} = 0.5\text{ V}$		$T_J = 25^\circ\text{C}$	78	100		
				$T_J = -40^\circ\text{C}$ to 125°C		75		

- (1) Electrical characteristics table values apply only for factory testing conditions at the temperature indicated. Factory testing conditions result in limited self-heating of the device such that $T_J = T_A$. No ensured specification of parametric performance is indicated in the electrical tables under conditions of internal self heating where $T_J > T_A$. *Absolute Maximum Ratings* indicated junction temperature limits beyond which the device may be permanently degraded, either mechanically or electrically.
- (2) All limits are specified by testing or statistical analysis.
- (3) Typical values represent the most likely parametric norm as determined at the time of characterization. Actual typical values may vary over time and also depend on the application and configuration. The typical values are not tested and are not ensured on shipped production material.
- (4) For ensured temperature ranges, see input common-mode voltage range specifications.

Electrical Characteristics – DC, 1.8 V (continued)

 $T_J = 25^\circ\text{C}$, $V^+ = 1.8\text{ V}$, $V^- = 0\text{ V}$, $V_{CM} = V^+/2$, $V_O = V^+/2$, $R_L > 1\text{ M}\Omega$, and $\overline{\text{SHDN}}$ tied to V^+ (unless otherwise noted)⁽¹⁾

PARAMETER		TEST CONDITIONS	MIN ⁽²⁾	TYP ⁽³⁾	MAX ⁽²⁾	UNIT	
V_O	Output swing	$R_L = 600\ \Omega$ to 0.9 V , $V_{IN} = \pm 100\text{ mV}$	$T_J = 25^\circ\text{C}$	1.65	1.72	V	
			$T_J = -40^\circ\text{C}$ to 125°C		0.077		0.105
		$R_L = 2\text{ k}\Omega$ to 0.9 V , $V_{IN} = \pm 100\text{ mV}$	$T_J = 25^\circ\text{C}$	1.75	1.77	V	
			$T_J = -40^\circ\text{C}$ to 125°C		0.024		0.035
			$T_J = 25^\circ\text{C}$	1.74			0.04
			$T_J = -40^\circ\text{C}$ to 125°C				
I_O	Output short circuit current ⁽⁵⁾	Sourcing, $V_O = 0\text{ V}$, $V_{IN} = 100\text{ mV}$	$T_J = 25^\circ\text{C}$	4	8	mA	
			$T_J = -40^\circ\text{C}$ to 125°C	3.3			
		Sinking, $V_O = 1.8\text{ V}$, $V_{IN} = -100\text{ mV}$	$T_J = 25^\circ\text{C}$	7	9		
			$T_J = -40^\circ\text{C}$ to 125°C	5			
T_{on}	Turnon time from shutdown		19		μs		
V_{SHDN}	Turnon voltage to enable part		1		V		
	Turnoff voltage		0.55				

(5) Applies to both single-supply and split-supply operation. Continuous short-circuit operation at elevated ambient temperature can result in exceeding the maximum allowed junction temperature of 150°C . Output currents in excess of 45 mA over long term may adversely affect reliability.

7.6 Electrical Characteristics – AC, 1.8 V

 $T_J = 25^\circ\text{C}$, $V^+ = 1.8\text{ V}$, $V^- = 0\text{ V}$, $V_{CM} = V^+/2$, $V_O = V^+/2$, $R_L > 1\text{ M}\Omega$, and $\overline{\text{SHDN}}$ tied to V^+ (unless otherwise noted)⁽¹⁾

PARAMETER		TEST CONDITIONS	MIN ⁽²⁾	TYP ⁽³⁾	MAX ⁽²⁾	UNIT
SR	Slew rate ⁽⁴⁾			0.35		$\text{V}/\mu\text{s}$
GBW	Gain-bandwidth product			1.4		MHz
Φ_m	Phase margin			67		$^\circ$
G_m	Gain margin			7		dB
e_n	Input-referred voltage noise	$f = 10\text{ kHz}$, $V_{CM} = 0.5\text{ V}$		60		$\text{nV}/\sqrt{\text{Hz}}$
i_n	Input-referred current noise	$f = 10\text{ kHz}$		0.08		$\text{pA}/\sqrt{\text{Hz}}$
THD	Total harmonic distortion	$f = 1\text{ kHz}$, $A_V = +1$, $R_L = 600\ \Omega$, $V_{IN} = 1\text{ V}_{PP}$		0.023%		
	Amp-to-amp isolation ⁽⁵⁾			123		dB

- Electrical characteristics table values apply only for factory testing conditions at the temperature indicated. Factory testing conditions result in limited self-heating of the device such that $T_J = T_A$. No ensured specification of parametric performance is indicated in the electrical tables under conditions of internal self heating where $T_J > T_A$. *Absolute Maximum Ratings* indicated junction temperature limits beyond which the device may be permanently degraded, either mechanically or electrically.
- All limits are specified by testing or statistical analysis.
- Typical values represent the most likely parametric norm as determined at the time of characterization. Actual typical values may vary over time and also depend on the application and configuration. The typical values are not tested and are not ensured on shipped production material.
- Connected as voltage follower with input step from V^- to V^+ . Number specified is the slower of the positive and negative slew rates.
- Input referred, $R_L = 100\text{ k}\Omega$ connected to $V^+/2$. Each amp excited in turn with 1 kHz to produce $V_O = 3\text{ V}_{PP}$ (for supply voltages $< 3\text{ V}$, $V_O = V^+$).

7.7 Electrical Characteristics – DC, 2.7 V

 $T_J = 25^\circ\text{C}$, $V^+ = 2.7\text{ V}$, $V^- = 0\text{ V}$, $V_{CM} = V^+/2$, $V_O = V^+/2$, $R_L > 1\text{ M}\Omega$, and $\overline{\text{SHDN}}$ tied to V^+ (unless otherwise noted)⁽¹⁾

PARAMETER		TEST CONDITIONS		MIN ⁽²⁾	TYP ⁽³⁾	MAX ⁽²⁾	UNIT	
V_{OS}	Input offset voltage	LMV981-N (single)	$T_J = 25^\circ\text{C}$		1	4	mV	
			$T_J = -40^\circ\text{C}$ to 125°C			6		
		LMV982-N (dual)	$T_J = 25^\circ\text{C}$		1	6	mV	
			$T_J = -40^\circ\text{C}$ to 125°C			7.5		
TCV_{OS}	Input offset voltage average drift				5.5		$\mu\text{V}/^\circ\text{C}$	
I_B	Input bias current	$T_J = 25^\circ\text{C}$			15	35	nA	
		$T_J = -40^\circ\text{C}$ to 125°C				50		
I_{OS}	Input offset current	$T_J = 25^\circ\text{C}$			8	25	nA	
		$T_J = -40^\circ\text{C}$ to 125°C				40		
I_S	Supply current (per channel)	$T_J = 25^\circ\text{C}$			105	190	μA	
		$T_J = -40^\circ\text{C}$ to 125°C				210		
		In shutdown	LMV981-N (single)	$T_J = 25^\circ\text{C}$		0.061		1
				$T_J = -40^\circ\text{C}$ to 125°C				2
			LMV982-N (dual)	$T_J = 25^\circ\text{C}$		0.101		3.5
				$T_J = -40^\circ\text{C}$ to 125°C				5
CMRR	Common mode rejection ratio	LMV981-N, $0\text{ V} \leq V_{CM} \leq 1.5\text{ V}$, $2.3\text{ V} \leq V_{CM} \leq 2.7\text{ V}$ ⁽⁴⁾		$T_J = 25^\circ\text{C}$	60	81	dB	
				$T_J = -40^\circ\text{C}$ to 125°C		55		
		LMV982, $0\text{ V} \leq V_{CM} \leq 1.5\text{ V}$, $2.3\text{ V} \leq V_{CM} \leq 2.7\text{ V}$ ⁽⁴⁾		$T_J = 25^\circ\text{C}$	55	80		
				$T_J = -40^\circ\text{C}$ to 125°C		50		
		$-0.2\text{ V} \leq V_{CM} \leq 0\text{ V}$, $2.7\text{ V} \leq V_{CM} \leq 2.9\text{ V}$			50	74		
PSRR	Power supply rejection ratio	$1.8\text{ V} \leq V^+ \leq 5\text{ V}$, $V_{CM} = 0.5\text{ V}$		$T_J = 25^\circ\text{C}$	75	100	dB	
				$T_J = -40^\circ\text{C}$ to 125°C		70		
CMVR	Input common mode voltage	For CMRR Range $\geq 50\text{ dB}$		$T_A = 25^\circ\text{C}$	$V^- - 0.2$	-0.2	V	
				$T_A = -40^\circ\text{C}$ to 85°C	V^-	$V^+ + 0.2$		
				$T_A = 125^\circ\text{C}$	$V^- + 0.2$	$V^+ - 0.2$		
A_V	Large signal voltage gain LMV981-N (single)	$R_L = 600\ \Omega$ to 1.35 V , $V_O = 0.2\text{ V}$ to 2.5 V		$T_J = 25^\circ\text{C}$	87	104	dB	
				$T_J = -40^\circ\text{C}$ to 125°C		86		
		$R_L = 2\text{ k}\Omega$ to 1.35 V , $V_O = 0.2\text{ V}$ to 2.5 V		$T_J = 25^\circ\text{C}$	92	110		
				$T_J = -40^\circ\text{C}$ to 125°C		91		
	Large signal voltage gain LMV982-N (dual)	$R_L = 600\ \Omega$ to 1.35 V , $V_O = 0.2\text{ V}$ to 2.5 V		$T_J = 25^\circ\text{C}$	78	90		
				$T_J = -40^\circ\text{C}$ to 125°C		75		
		$R_L = 2\text{ k}\Omega$ to 1.35 V , $V_O = 0.2\text{ V}$ to 2.5 V		$T_J = 25^\circ\text{C}$	81	100		
				$T_J = -40^\circ\text{C}$ to 125°C		78		

- (1) Electrical characteristics table values apply only for factory testing conditions at the temperature indicated. Factory testing conditions result in limited self-heating of the device such that $T_J = T_A$. No ensured specification of parametric performance is indicated in the electrical tables under conditions of internal self heating where $T_J > T_A$. *Absolute Maximum Ratings* indicated junction temperature limits beyond which the device may be permanently degraded, either mechanically or electrically.
- (2) All limits are specified by testing or statistical analysis.
- (3) Typical values represent the most likely parametric norm as determined at the time of characterization. Actual typical values may vary over time and also depend on the application and configuration. The typical values are not tested and are not ensured on shipped production material.
- (4) For ensured temperature ranges, see input common mode voltage range specifications.

Electrical Characteristics – DC, 2.7 V (continued)

 $T_J = 25^\circ\text{C}$, $V^+ = 2.7\text{ V}$, $V^- = 0\text{ V}$, $V_{\text{CM}} = V^+/2$, $V_O = V^+/2$, $R_L > 1\text{ M}\Omega$, and $\overline{\text{SHDN}}$ tied to V^+ (unless otherwise noted)⁽¹⁾

PARAMETER		TEST CONDITIONS		MIN ⁽²⁾	TYP ⁽³⁾	MAX ⁽²⁾	UNIT
V_O	Output swing	$R_L = 600\ \Omega$ to 1.35 V , $V_{\text{IN}} = \pm 100\text{ mV}$	$T_J = 25^\circ\text{C}$	2.55	2.62		V
			$T_J = -40^\circ\text{C}$ to 125°C		0.083	0.11	
			$T_J = 25^\circ\text{C}$	2.65	2.675		
			$T_J = -40^\circ\text{C}$ to 125°C	2.64		0.045	
		$R_L = 2\text{ k}\Omega$ to 1.35 V , $V_{\text{IN}} = \pm 100\text{ mV}$	$T_J = 25^\circ\text{C}$		0.025	0.04	
			$T_J = -40^\circ\text{C}$ to 125°C				
I_O	Output short circuit current ⁽⁵⁾	Sourcing, $V_O = 0\text{ V}$, $V_{\text{IN}} = 100\text{ mV}$	$T_J = 25^\circ\text{C}$	20	30		mA
			$T_J = -40^\circ\text{C}$ to 125°C	15			
		Sinking, $V_O = 0\text{ V}$, $V_{\text{IN}} = -100\text{ mV}$	$T_J = 25^\circ\text{C}$	18	25		
			$T_J = -40^\circ\text{C}$ to 125°C	12			
T_{on}	Turnon time from shutdown			12.5		μs	
V_{SHDN}	Turnon voltage to enable part			1.9		V	
	Turnoff voltage			0.8			

(5) Applies to both single-supply and split-supply operation. Continuous short-circuit operation at elevated ambient temperature can result in exceeding the maximum allowed junction temperature of 150°C . Output currents in excess of 45 mA over long term may adversely affect reliability.

7.8 Electrical Characteristics – AC, 2.7 V

 $T_J = 25^\circ\text{C}$, $V^+ = 2.7\text{ V}$, $V^- = 0\text{ V}$, $V_{\text{CM}} = 1\text{ V}$, $V_O = 1.35\text{ V}$, $R_L > 1\text{ M}\Omega$, and $\overline{\text{SHDN}}$ tied to V^+ (unless otherwise noted)⁽¹⁾

PARAMETER		TEST CONDITIONS		MIN ⁽²⁾	TYP ⁽³⁾	MAX ⁽²⁾	UNIT
SR	Slew rate ⁽⁴⁾				0.4		$\text{V}/\mu\text{s}$
GBW	Gain-bandwidth product				1.4		MHz
Φ_m	Phase margin				70		$^\circ$
G_m	Gain margin				7.5		dB
e_n	Input-referred voltage noise	$f = 10\text{ kHz}$, $V_{\text{CM}} = 0.5\text{ V}$			57		$\text{nV}/\sqrt{\text{Hz}}$
i_n	Input-referred current noise	$f = 10\text{ kHz}$			0.08		$\text{pA}/\sqrt{\text{Hz}}$
THD	Total harmonic distortion	$f = 1\text{ kHz}$, $A_V = +1$, $R_L = 600\ \Omega$, $V_{\text{IN}} = 1\text{ V}_{\text{PP}}$			0.022%		
	Amp-to-amp isolation ⁽⁵⁾				123		dB

- (1) Electrical characteristics table values apply only for factory testing conditions at the temperature indicated. Factory testing conditions result in limited self-heating of the device such that $T_J = T_A$. No ensured specification of parametric performance is indicated in the electrical tables under conditions of internal self heating where $T_J > T_A$. *Absolute Maximum Ratings* indicated junction temperature limits beyond which the device may be permanently degraded, either mechanically or electrically.
- (2) All limits are specified by testing or statistical analysis.
- (3) Typical values represent the most likely parametric norm as determined at the time of characterization. Actual typical values may vary over time and also depend on the application and configuration. The typical values are not tested and are not ensured on shipped production material.
- (4) Connected as voltage follower with input step from V^- to V^+ . Number specified is the slower of the positive and negative slew rates.
- (5) Input referred, $R_L = 100\text{ k}\Omega$ connected to $V^+/2$. Each amp excited in turn with 1 kHz to produce $V_O = 3\text{ V}_{\text{PP}}$ (for supply voltages $< 3\text{ V}$, $V_O = V^+$).

7.9 Electrical Characteristics – DC, 5 V

 $T_J = 25^\circ\text{C}$, $V^+ = 5\text{ V}$, $V^- = 0\text{ V}$, $V_{CM} = V^+/2$, $V_O = V^+/2$, $R_L > 1\text{ M}\Omega$, and $\overline{\text{SHDN}}$ tied to V^+ (unless otherwise noted)⁽¹⁾

PARAMETER		TEST CONDITIONS		MIN ⁽²⁾	TYP ⁽³⁾	MAX ⁽²⁾	UNIT	
V_{OS}	Input offset voltage	LMV981-N (single)	$T_J = 25^\circ\text{C}$		1	4	mV	
			$T_J = -40^\circ\text{C}$ to 125°C			6		
		LMV982-N (dual)	$T_J = 25^\circ\text{C}$		1	5.5		
			$T_J = -40^\circ\text{C}$ to 125°C			7.5		
TCV_{OS}	Input offset voltage average drift			5.5		$\mu\text{V}/^\circ\text{C}$		
I_B	Input bias current	$T_J = 25^\circ\text{C}$		14	35	nA		
		$T_J = -40^\circ\text{C}$ to 125°C			50			
I_{OS}	Input offset current	$T_J = 25^\circ\text{C}$		9	25	nA		
		$T_J = -40^\circ\text{C}$ to 125°C			40			
I_S	Supply current (per channel)	$T_J = 25^\circ\text{C}$		116	210	μA		
		$T_J = -40^\circ\text{C}$ to 125°C			230			
		In shutdown	LMV981-N (single)	$T_J = 25^\circ\text{C}$		0.201	1	μA
				$T_J = -40^\circ\text{C}$ to 125°C			2	
	LMV982-N (dual)	$T_J = 25^\circ\text{C}$		0.302	3.5			
		$T_J = -40^\circ\text{C}$ to 125°C			5			
$CMRR$	Common mode rejection ratio ⁽⁴⁾	$0\text{ V} \leq V_{CM} \leq 3.8\text{ V}$, $4.6\text{ V} \leq V_{CM} \leq 5\text{ V}$	$T_J = 25^\circ\text{C}$	60	86	dB		
			$T_J = -40^\circ\text{C}$ to 125°C	55				
		$-0.2\text{ V} \leq V_{CM} \leq 0\text{ V}$, $5\text{ V} \leq V_{CM} \leq 5.2\text{ V}$		50	78			
$PSRR$	Power supply rejection ratio	$1.8\text{ V} \leq V^+ \leq 5\text{ V}$, $V_{CM} = 0.5\text{ V}$	$T_J = 25^\circ\text{C}$	75	100	dB		
			$T_J = -40^\circ\text{C}$ to 125°C	70				
$CMVR$	Input common mode voltage	For CMRR range $\geq 50\text{ dB}$	$T_A = 25^\circ\text{C}$	$V^- - 0.2$	-0.2	V		
			$T_A = -40^\circ\text{C}$ to 85°C	V^-	$V^+ + 0.2$			
			$T_A = 125^\circ\text{C}$	$V^- + 0.3$	$V^+ - 0.3$			
A_V	Large signal voltage gain LMV981-N (single)	$R_L = 600\ \Omega$ to 2.5 V , $V_O = 0.2\text{ V}$ to 4.8 V	$T_J = 25^\circ\text{C}$	88	102	dB		
			$T_J = -40^\circ\text{C}$ to 125°C	87				
		$R_L = 2\text{ k}\Omega$ to 2.5 V , $V_O = 0.2\text{ V}$ to 4.8 V	$T_J = 25^\circ\text{C}$	94	113			
			$T_J = -40^\circ\text{C}$ to 125°C	93				
	Large signal voltage gain LMV982-N (dual)	$R_L = 600\ \Omega$ to 2.5 V , $V_O = 0.2\text{ V}$ to 4.8 V	$T_J = 25^\circ\text{C}$	81	90	dB		
			$T_J = -40^\circ\text{C}$ to 125°C	78				
	$R_L = 2\text{ k}\Omega$ to 2.5 V , $V_O = 0.2\text{ V}$ to 4.8 V	$T_J = 25^\circ\text{C}$	85	100				
$T_J = -40^\circ\text{C}$ to 125°C		82						
V_O	Output swing	$R_L = 600\ \Omega$ to 2.5 V , $V_{IN} = \pm 100\text{ mV}$	$T_J = 25^\circ\text{C}$	4.855	4.89	V		
			$T_J = -40^\circ\text{C}$ to 125°C	4.835	0.12		0.16	
		$R_L = 2\text{ k}\Omega$ to 2.5 V , $V_{IN} = \pm 100\text{ mV}$	$T_J = 25^\circ\text{C}$	4.945	4.967			
			$T_J = -40^\circ\text{C}$ to 125°C	4.935	0.037		0.065	

- (1) Electrical characteristics table values apply only for factory testing conditions at the temperature indicated. Factory testing conditions result in limited self-heating of the device such that $T_J = T_A$. No ensured specification of parametric performance is indicated in the electrical tables under conditions of internal self heating where $T_J > T_A$. *Absolute Maximum Ratings* indicated junction temperature limits beyond which the device may be permanently degraded, either mechanically or electrically.
- (2) All limits are specified by testing or statistical analysis.
- (3) Typical values represent the most likely parametric norm as determined at the time of characterization. Actual typical values may vary over time and also depend on the application and configuration. The typical values are not tested and are not ensured on shipped production material.
- (4) For ensured temperature ranges, see input common mode voltage range specifications.

Electrical Characteristics – DC, 5 V (continued)

 $T_J = 25^\circ\text{C}$, $V^+ = 5\text{ V}$, $V^- = 0\text{ V}$, $V_{CM} = V^+/2$, $V_O = V^+/2$, $R_L > 1\text{ M}\Omega$, and $\overline{\text{SHDN}}$ tied to V^+ (unless otherwise noted)⁽¹⁾

PARAMETER		TEST CONDITIONS		MIN ⁽²⁾	TYP ⁽³⁾	MAX ⁽²⁾	UNIT
I_O	Output short-circuit current ⁽⁵⁾	LMV981-N, sourcing, $V_O = 0\text{ V}$, $V_{IN} = 100\text{ mV}$	$T_J = 25^\circ\text{C}$	80	100		mA
			$T_J = -40^\circ\text{C}$ to 125°C	68			
		Sinking, $V_O = 5\text{ V}$, $V_{IN} = -100\text{ mV}$	$T_J = 25^\circ\text{C}$	58	65		
			$T_J = -40^\circ\text{C}$ to 125°C	45			
T_{on}	Turnon time from shutdown				8.4		μs
V_{SHDN}	Turnon voltage to enable part				4.2		V
	Turnoff voltage				0.8		

(5) Applies to both single-supply and split-supply operation. Continuous short-circuit operation at elevated ambient temperature can result in exceeding the maximum allowed junction temperature of 150°C . Output currents in excess of 45 mA over long term may adversely affect reliability.

7.10 Electrical Characteristics – AC, 5 V

 $T_J = 25^\circ\text{C}$, $V^+ = 5\text{ V}$, $V^- = 0\text{ V}$, $V_{CM} = V^+/2$, $V_O = 2.5\text{ V}$, $R_L > 1\text{ M}\Omega$, and $\overline{\text{SHDN}}$ tied to V^+ (unless otherwise noted)⁽¹⁾

PARAMETER		TEST CONDITIONS		MIN ⁽²⁾	TYP ⁽³⁾	MAX ⁽²⁾	UNIT
SR	Slew rate ⁽⁴⁾				0.42		V/ μs
GBW	Gain-bandwidth product				1.5		MHz
Φ_m	Phase margin				71		$^\circ$
G_m	Gain margin				8		dB
e_n	Input-referred voltage noise	$f = 10\text{ kHz}$, $V_{CM} = 1\text{ V}$			50		$\text{nV}/\sqrt{\text{Hz}}$
i_n	Input-referred current noise	$f = 10\text{ kHz}$			0.08		$\text{pA}/\sqrt{\text{Hz}}$
THD	Total harmonic distortion	$f = 1\text{ kHz}$, $A_V = +1$, $R_L = 600\ \Omega$, $V_O = 1\text{ V}_{PP}$			0.022%		
	Amp-to-amp isolation ⁽⁵⁾				123		dB

- (1) Electrical characteristics table values apply only for factory testing conditions at the temperature indicated. Factory testing conditions result in limited self-heating of the device such that $T_J = T_A$. No ensured specification of parametric performance is indicated in the electrical tables under conditions of internal self heating where $T_J > T_A$. *Absolute Maximum Ratings* indicated junction temperature limits beyond which the device may be permanently degraded, either mechanically or electrically.
- (2) All limits are specified by testing or statistical analysis.
- (3) Typical values represent the most likely parametric norm as determined at the time of characterization. Actual typical values may vary over time and also depend on the application and configuration. The typical values are not tested and are not ensured on shipped production material.
- (4) Connected as voltage follower with input step from V^- to V^+ . Number specified is the slower of the positive and negative slew rates.
- (5) Input referred, $R_L = 100\text{ k}\Omega$ connected to $V^+/2$. Each amp excited in turn with 1 kHz to produce $V_O = 3\text{ V}_{PP}$ (for supply voltages $< 3\text{ V}$, $V_O = V^+$).

7.11 Typical Characteristics

$V_S = 5\text{ V}$, single supply, and $T_A = 25^\circ\text{C}$ (unless otherwise noted)

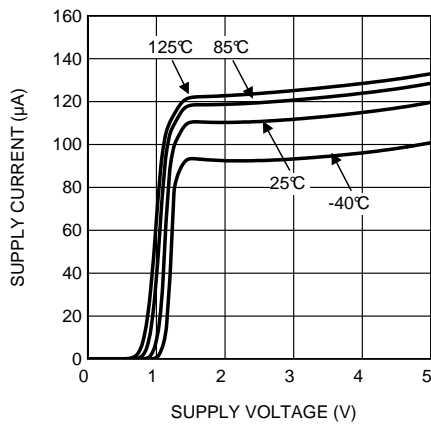

Figure 1. Supply Current vs Supply Voltage (LMV981-N)

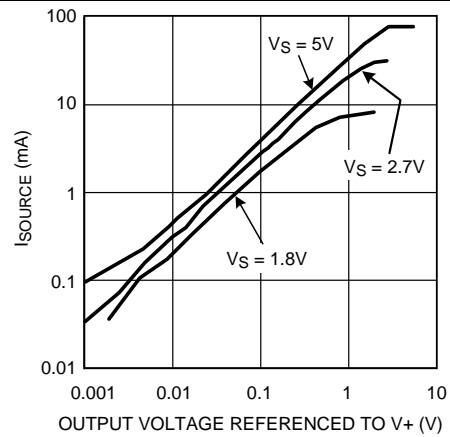

Figure 2. Sourcing Current vs Output Voltage

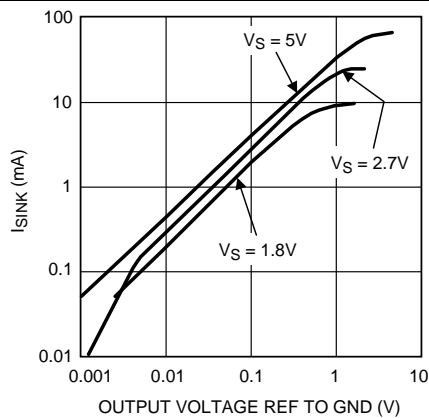

Figure 3. Sinking Current vs Output Voltage

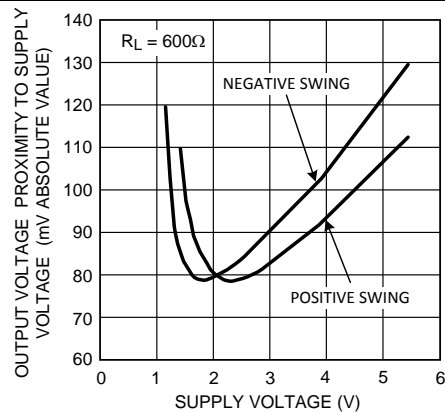

Figure 4. Output Voltage Swing vs Supply Voltage

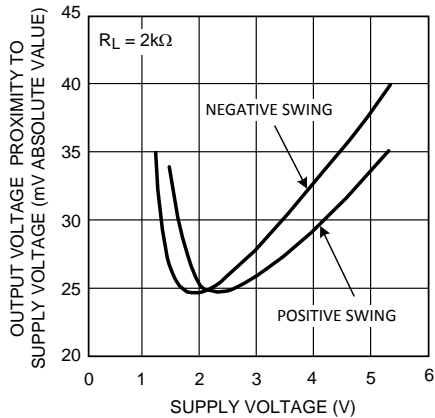

Figure 5. Output Voltage Swing vs Supply Voltage

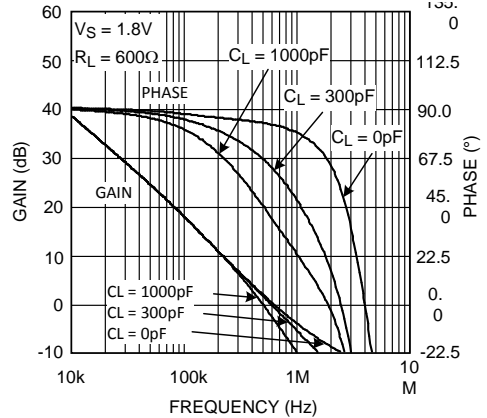

Figure 6. Gain and Phase vs Frequency

Typical Characteristics (continued)

$V_S = 5\text{ V}$, single supply, and $T_A = 25^\circ\text{C}$ (unless otherwise noted)

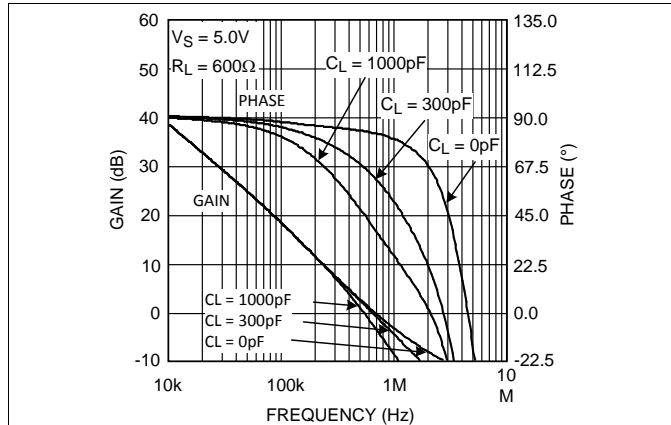

Figure 7. Gain and Phase vs Frequency

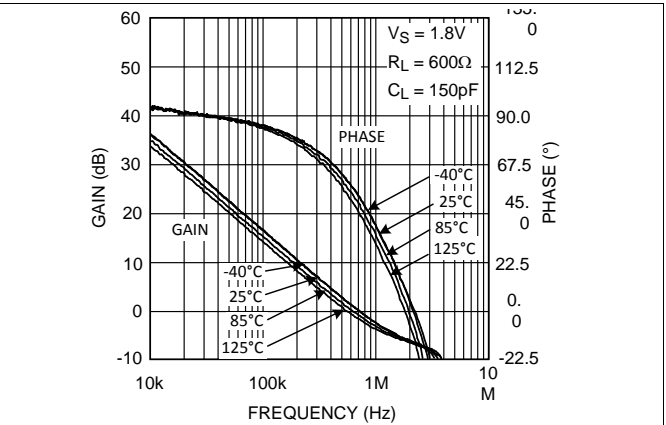

Figure 8. Gain and Phase vs Frequency

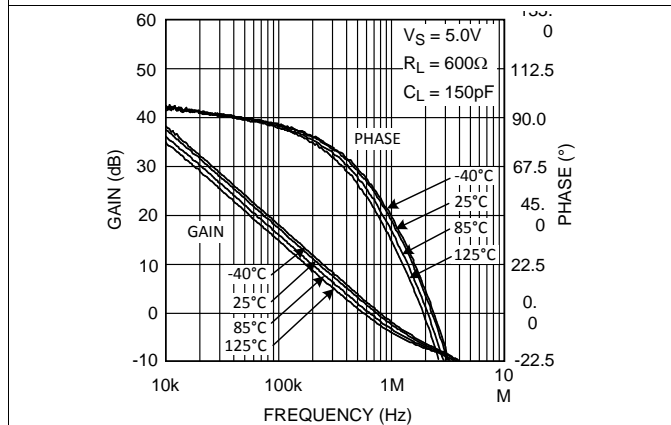

Figure 9. Gain and Phase vs Frequency

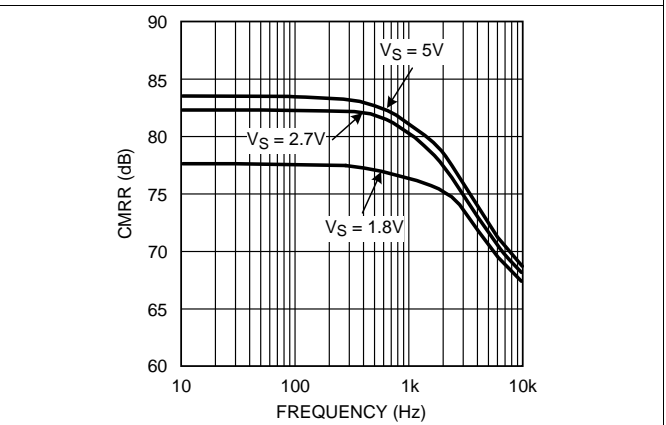

Figure 10. CMRR vs Frequency

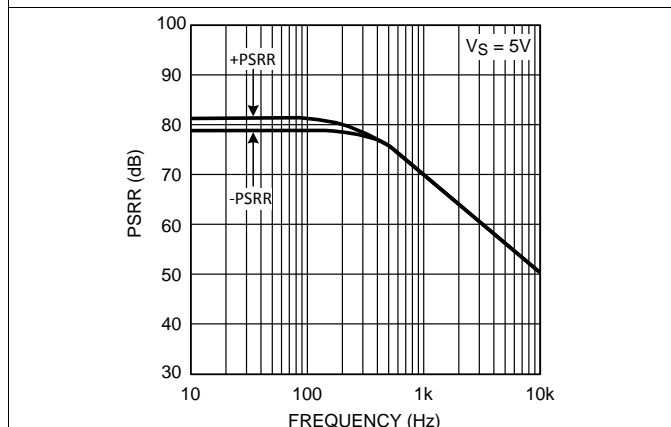

Figure 11. PSRR vs Frequency

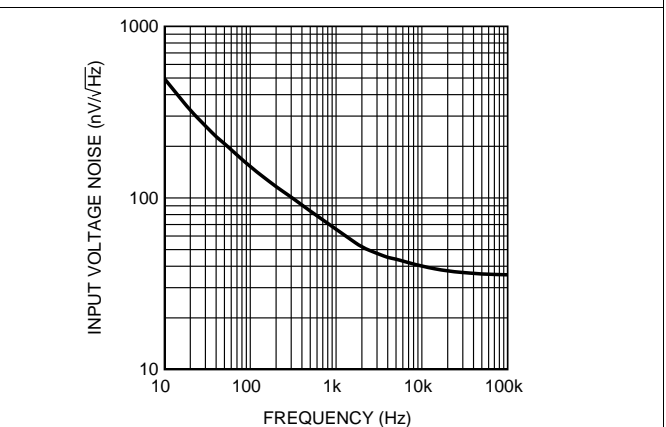
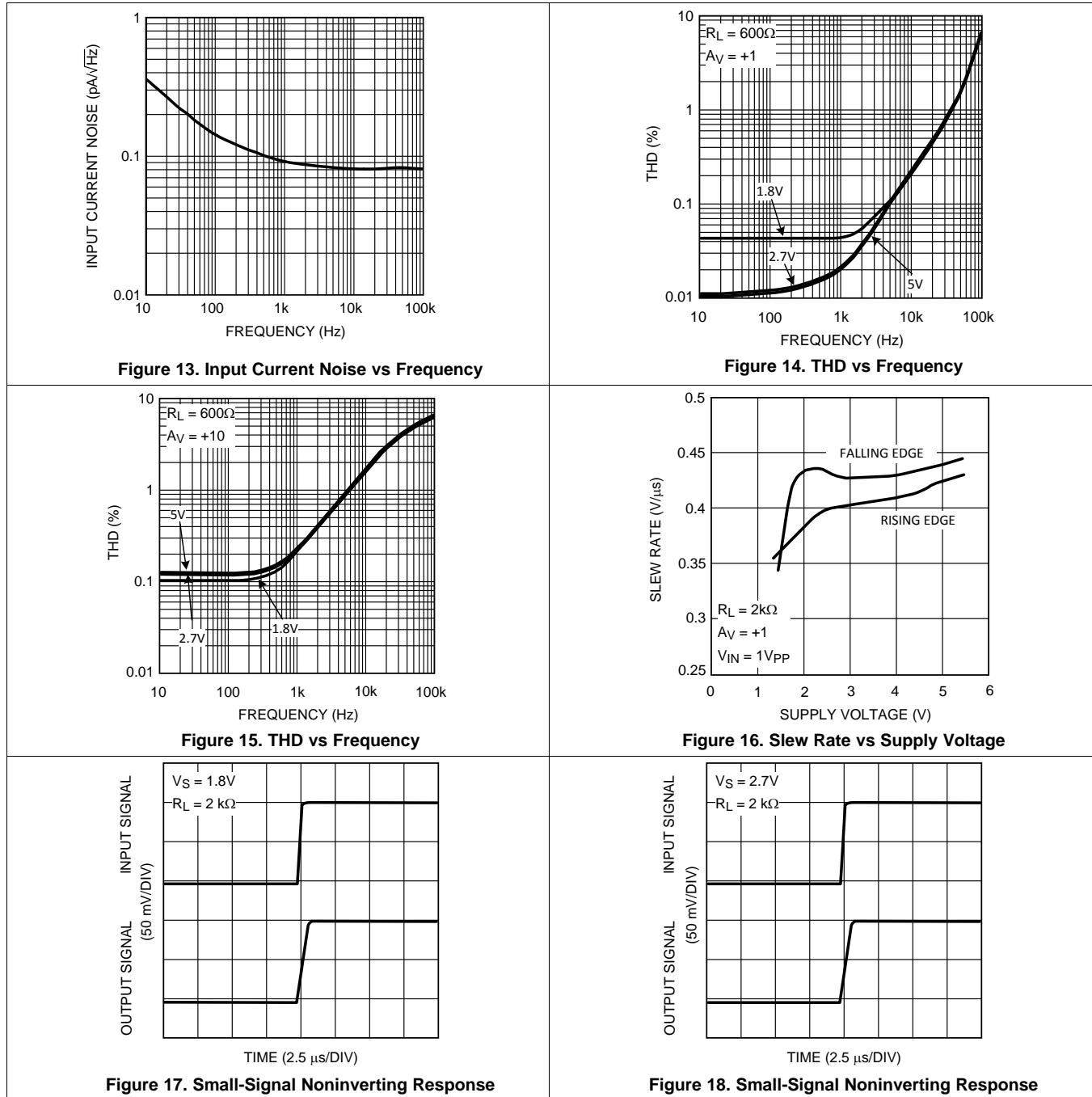

Figure 12. Input Voltage Noise vs Frequency

Typical Characteristics (continued)

$V_S = 5\text{ V}$, single supply, and $T_A = 25^\circ\text{C}$ (unless otherwise noted)



Typical Characteristics (continued)

$V_S = 5\text{ V}$, single supply, and $T_A = 25^\circ\text{C}$ (unless otherwise noted)

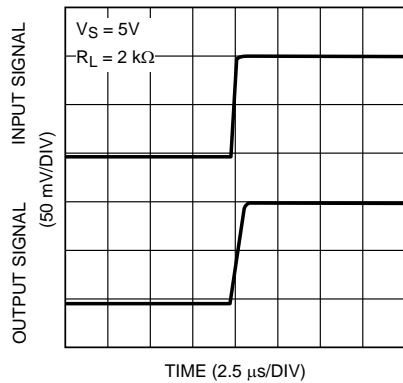

Figure 19. Small-Signal Noninverting Response

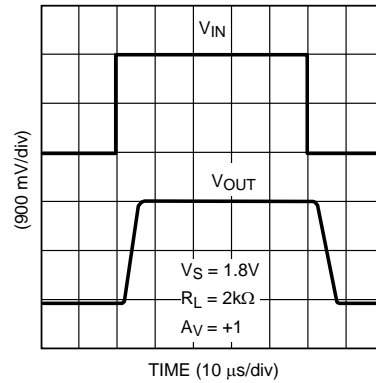

Figure 20. Large-Signal Noninverting Response

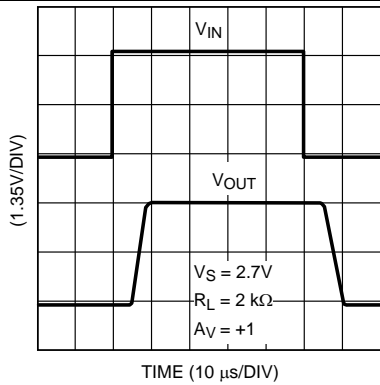

Figure 21. Large-Signal Noninverting Response

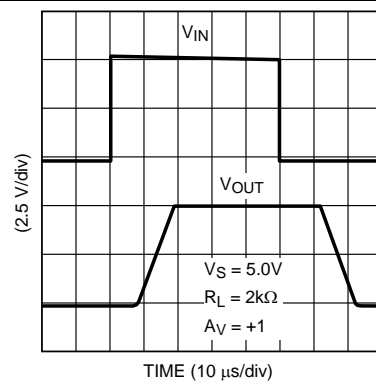

Figure 22. Large-Signal Noninverting Response

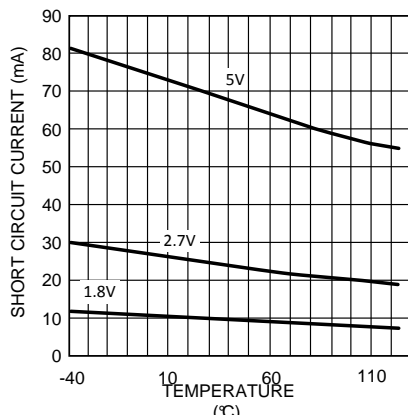

Figure 23. Short-Circuit Current vs Temperature (Sinking)

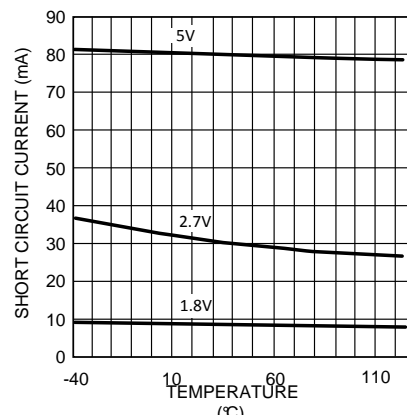

Figure 24. Short-Circuit Current vs Temperature (Sourcing)

Typical Characteristics (continued)

$V_S = 5\text{ V}$, single supply, and $T_A = 25^\circ\text{C}$ (unless otherwise noted)

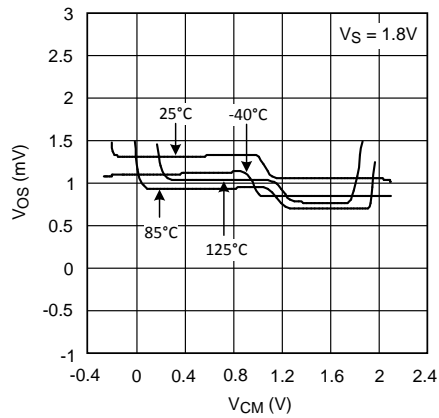

Figure 25. Offset Voltage vs Common Mode Range

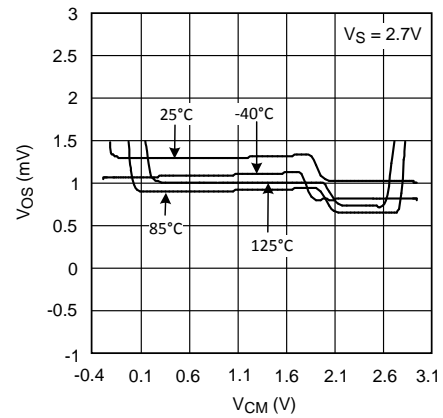

Figure 26. Offset Voltage vs Common Mode Range

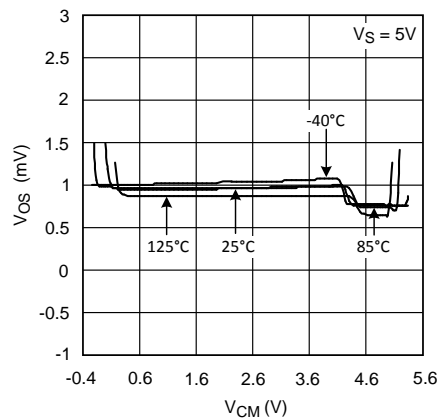

Figure 27. Offset Voltage vs Common Mode Range

8 Detailed Description

8.1 Overview

The LMV98x-N are low-voltage, low-power operational amplifiers (op-amp) operating from 1.8-V to 5.5-V supply voltages and have rail-to-rail input and output with shutdown. LMV98x-N input common-mode voltage extends 200 mV beyond the supplies which enables user enhanced functionality beyond the supply voltage range.

8.2 Functional Block Diagram

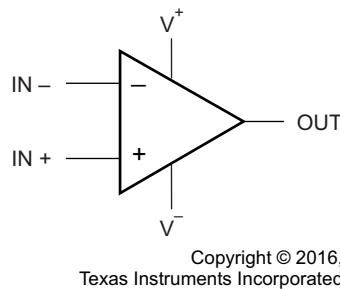

(each amplifier)

8.3 Feature Description

The differential inputs of the amplifier consist of a noninverting input (+IN) and an inverting input (–IN). The amplifier amplifies only the difference in voltage between the two inputs, which is called the differential input voltage. The output voltage of the op-amp V_{OUT} is given by [Equation 1](#):

$$V_{OUT} = A_{OL} (IN^+ - IN^-)$$

where

- A_{OL} is the open-loop gain of the amplifier, typically around 100 dB (100,000x, or 10 μ V per volt). (1)

8.4 Device Functional Modes

8.4.1 Input and Output Stage

The rail-to-rail input stage of this family provides more flexibility for the designer. The LMV98x-N use a complimentary PNP and NPN input stage in which the PNP stage senses common-mode voltage near V^- and the NPN stage senses common-mode voltage near V^+ . The transition from the PNP stage to NPN stage occurs 1 V below V^+ . Because both input stages have their own offset voltage, the offset of the amplifier becomes a function of the input common-mode voltage and has a crossover point at 1 V below V^+ .

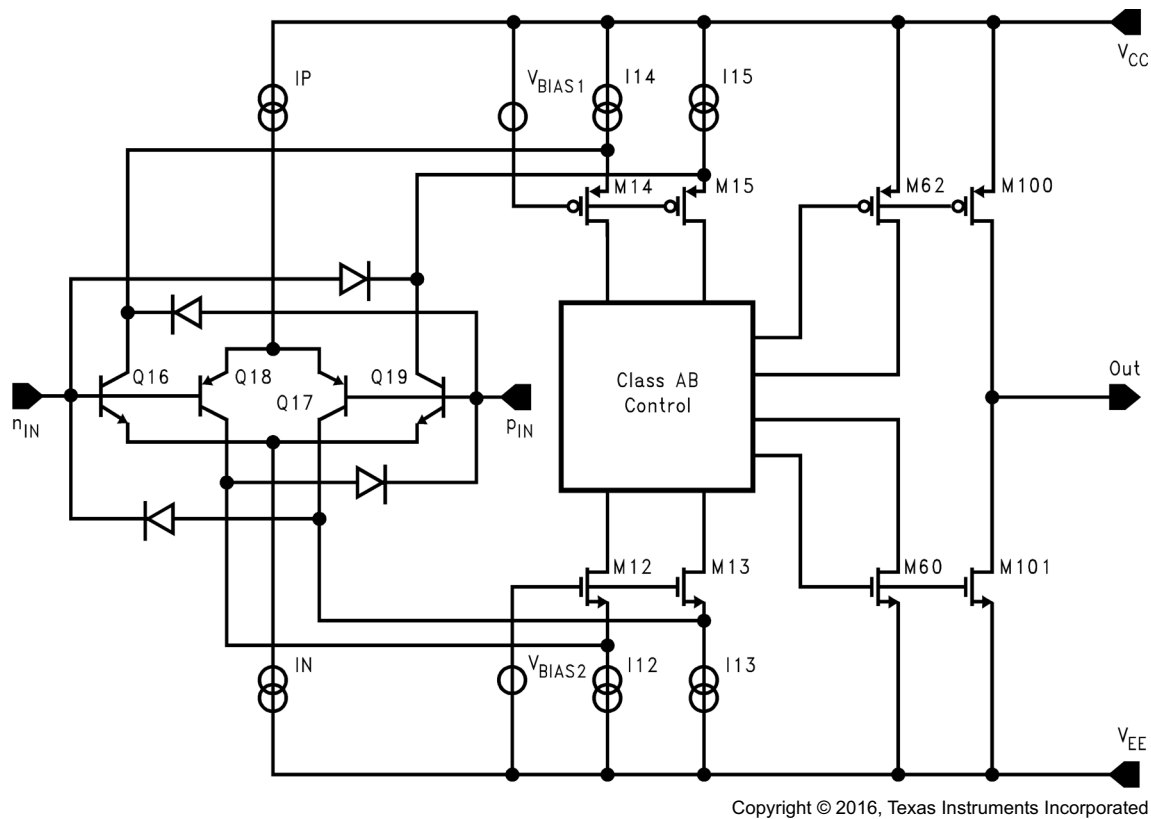
Device Functional Modes (continued)

Figure 28. Simplified Schematic Diagram

This V_{OS} crossover point can create problems for both DC- and AC-coupled signals if proper care is not taken. Large input signals that include the V_{OS} crossover point causes distortion in the output signal. One way to avoid such distortion is to keep the signal away from the crossover. For example, in a unity gain buffer configuration with $V_S = 5\text{ V}$, a 5-V peak-to-peak signal centered at 1.5 V does not contain input-crossover distortion while a 3-V peak-to-peak signal centered at 1.5 V does contain input-crossover distortion. Another way to avoid large signal distortion is to use a gain of -1 circuit which avoids any voltage excursions at the input terminals of the amplifier. In that circuit, the common-mode DC voltage can be set at a level away from the V_{OS} cross-over point. For small signals, this transition in V_{OS} shows up as a V_{CM} dependent spurious signal in series with the input signal and can effectively degrade small-signal parameters such as gain and common-mode rejection ratio. To resolve this problem, the small signal must be placed such that it avoids the V_{OS} crossover point. In addition to the rail-to-rail performance, the output stage can provide enough output current to drive 600- Ω loads. Because of the high-current capability, take care not to exceed the 150°C maximum junction temperature specification.

8.4.2 Shutdown Mode

The LMV98x-N family has a shutdown pin. To conserve battery life in portable applications, the LMV98x-N can be disabled when the shutdown pin voltage is pulled low. When in shutdown, the output stage is in a high-impedance state and the input bias current drops to less than 1 nA.

The shutdown pin cannot be left unconnected. In case shut-down operation is not required, the shutdown pin must be connected to $V+$ when the LMV98x-N are used. Leaving the shutdown pin floating results in an undefined operation mode, either shutdown or active, or even oscillating between the two modes.

Device Functional Modes (continued)

8.4.3 Input Bias Current Consideration

The LMV98x-N family has a complementary bipolar input stage. The typical input bias current (I_B) is 15 nA. The input bias current can develop a significant offset voltage. This offset is primarily due to I_B flowing through the negative feedback resistor, R_F . For example, if I_B is 50 nA and R_F is 100 k Ω , then an offset voltage of 5 mV develops ($V_{OS} = I_B \times R_F$). Using a compensation resistor (R_C), as shown in Figure 29, cancels this effect. But the input offset current (I_{OS}) still contributes to an offset voltage in the same manner.

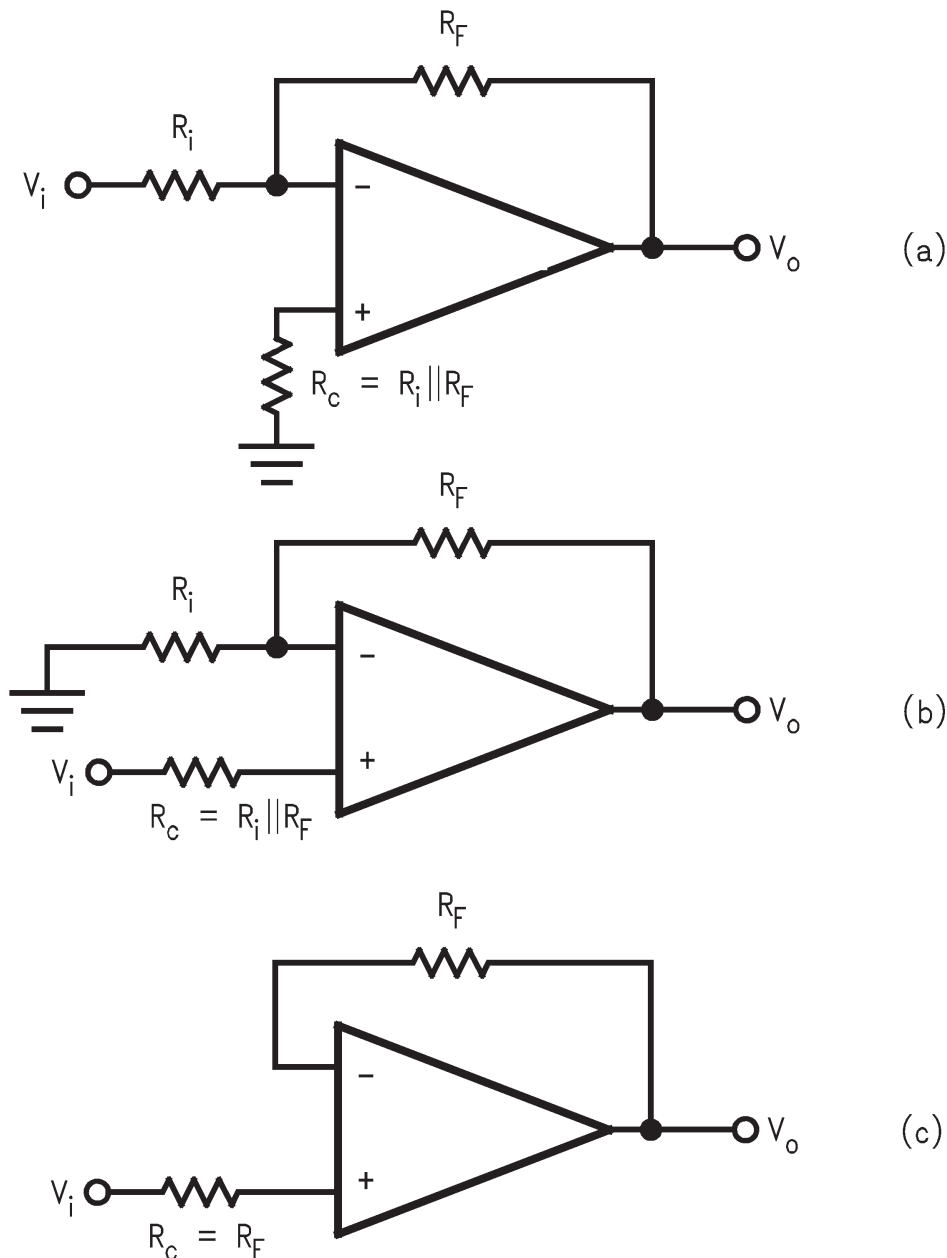

Figure 29. Canceling the Offset Voltage due to Input Bias Current

9 Application and Implementation

NOTE

Information in the following applications sections is not part of the TI component specification, and TI does not warrant its accuracy or completeness. TI's customers are responsible for determining suitability of components for their purposes. Customers should validate and test their design implementation to confirm system functionality.

9.1 Application Information

The LMV98x-N devices bring performance, economy, and ease-of-use to low-voltage, low-power systems. They provide rail-to-rail input and rail-to-rail output swings into heavy loads.

9.2 Typical Applications

9.2.1 High-Side Current-Sensing Application

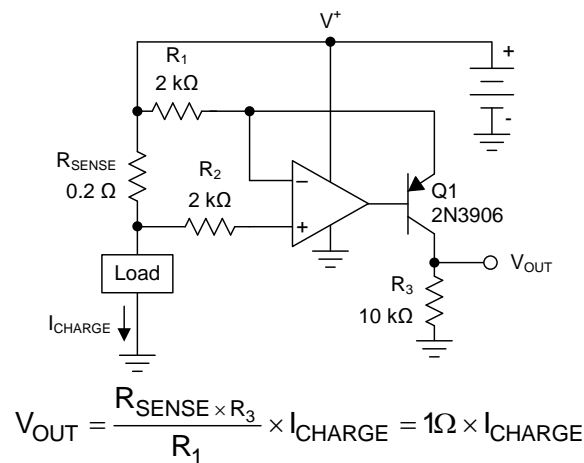

Copyright © 2016, Texas Instruments Incorporated

Figure 30. High-Side Current Sensing

9.2.1.1 Design Requirements

The high-side current-sensing circuit (Figure 30) is commonly used in a battery charger to monitor charging current to prevent overcharging. A sense resistor R_{SENSE} is connected to the battery directly. This system requires an op amp with rail-to-rail input. The LMV98x-N are ideal for this application because its common-mode input range extends up to the positive supply.

9.2.1.2 Detailed Design Procedure

As seen in Figure 30, the I_{CHARGE} current flowing through sense resistor R_{SENSE} develops a voltage drop equal to V_{SENSE} . The voltage at the negative sense point is now less than the positive sense point by an amount proportional to the V_{SENSE} voltage.

The low-bias currents of the LMV98x cause little voltage drop through R_2 , so the negative input of the LMV98x amplifier is at essentially the same potential as the negative sense input.

The LMV98x detects this voltage error between its inputs and servo the transistor base to conduct more current through Q1, increasing the voltage drop across R_1 until the LMV98x inverting input matches the noninverting input. At this point, the voltage drop across R_1 now matches V_{SENSE} .

I_G , a current proportional to I_{CHARGE} , flows according to Equation 2.

$$I_G = V_{SENSE} / R_1 = (R_{SENSE} \times I_{CHARGE}) / R_1 \quad (2)$$

Typical Applications (continued)

I_G also flows through the gain resistor R_3 developing a voltage drop equal to Equation 3 and Equation 4.

$$V_3 = I_G \times R_3 = (V_{RSENSE} / R_1) \times R_3 = ((R_{SENSE} \times I_{CHARGE}) / R_2) \times R_3 \quad (3)$$

$$V_{OUT} = (R_{SENSE} \times I_{CHARGE}) \times G$$

where

- $G = R_3 / R_1$ (4)

The other channel of the LMV98x may be used to buffer the voltage across R_3 to drive the following stages.

9.2.1.3 Application Curve

Figure 31 shows the results of the example current sense circuit. After 4 V, there is an error where transistor Q1 runs out of headroom and saturates, limiting the upper output swing.

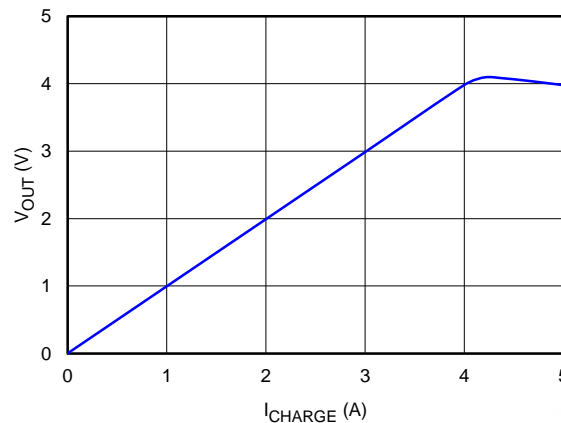

Figure 31. Current Sense Amplifier Results

9.2.2 Half-Wave Rectifier Applications

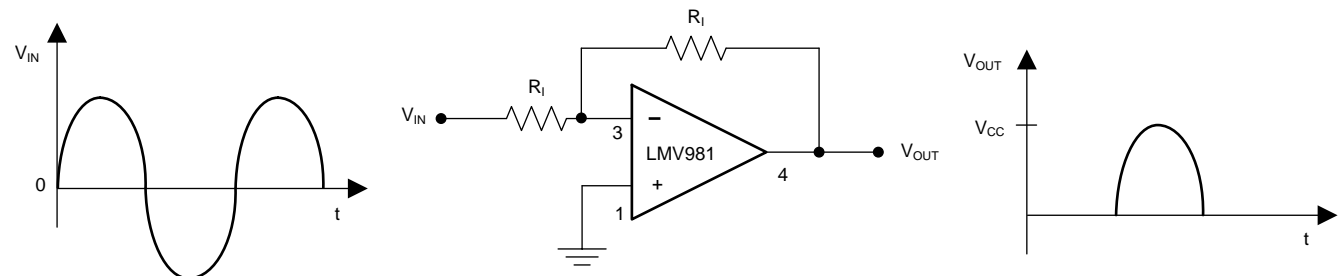

Figure 32. Half-Wave Rectifier With Rail-To-Ground Output Swing Referenced to Ground

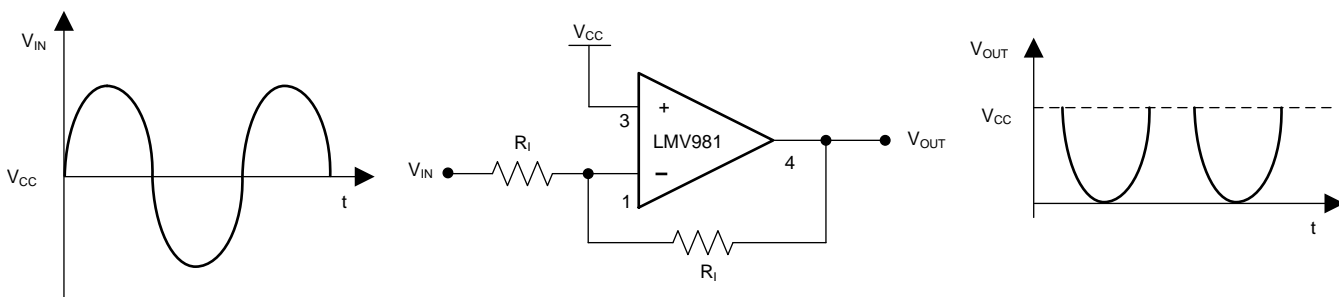

Figure 33. Half-Wave Rectifier With Negative-Going Output Referenced to V_{CC}

Typical Applications (continued)

9.2.2.1 Design Requirements

Because the LMV98x-N input common-mode range includes both positive and negative supply rails and the output can also swing to either supply, achieving half-wave rectifier functions in either direction is an easy task. All that is required are two external resistors; there is no requirement for diodes or matched resistors. The half-wave rectifier can have either positive or negative going outputs, depending on the way the circuit is arranged.

9.2.2.2 Detailed Design Procedure

In [Figure 32](#) the circuit is referenced to ground, while in [Figure 33](#) the circuit is biased to the positive supply. These configurations implement the half-wave rectifier because the LMV98x-N can not respond to one-half of the incoming waveform. It can not respond to one-half of the incoming because the amplifier cannot swing the output beyond either rail; therefore, the output disengages during this half cycle. During the other half cycle, however, the amplifier achieves a half wave that can have a peak equal to the total supply voltage. R_1 must be large enough not to load the LMV98x-N.

9.2.2.3 Application Curves

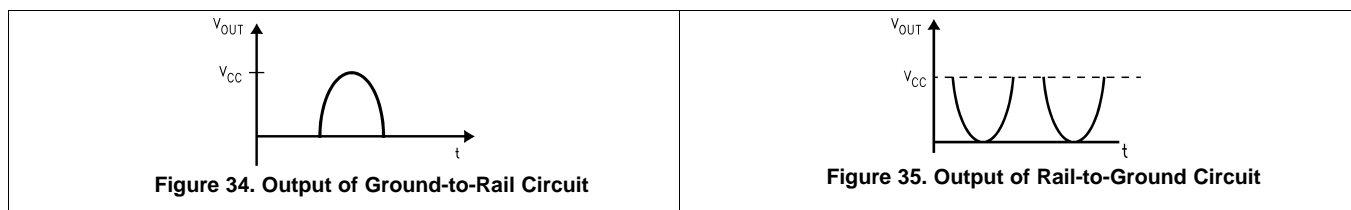

9.2.3 Instrumentation Amplifier With Rail-to-Rail Input and Output Application

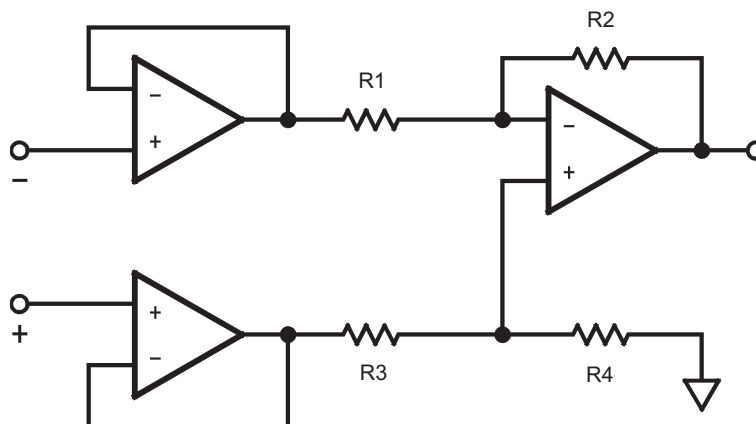

Figure 36. Rail-to-Rail Instrumentation Amplifier

9.2.3.1 Design Requirements

Using three of the LMV98x-N amplifiers, an instrumentation amplifier with rail-to-rail inputs and outputs can be made as shown in [Figure 36](#).

9.2.3.2 Detailed Design Procedure

In this example, amplifiers on the left side act as buffers to the differential stage. These buffers assure that the input impedance is high. They also assure that the difference amp is driven from a voltage source. This is necessary to maintain the CMRR set by the matching R_1 to R_2 with R_3 to R_4 . The gain is set by the ratio of R_2/R_1 and R_3 must equal R_1 and R_4 equal R_2 . With both rail-to-rail input and output ranges, the input and output are only limited by the supply voltages. Remember that even with rail-to-rail outputs, the output can not swing past the supplies so the combined common-mode voltages plus the signal must not be greater than the supplies or limiting occurs.

Typical Applications (continued)

9.2.3.3 Application Curve

Figure 37 shows the results of the instrumentation amplifier with R_1 and $R_3 = 1\text{ K}$, and R_2 and $R_4 = 100\text{ k}\Omega$, for a gain of 100, running on a single 5-V supply with a input of $V_{CM} = V_S/2$. The combined effects of the individual offset voltages can be seen as a shift in the offset of the curve.

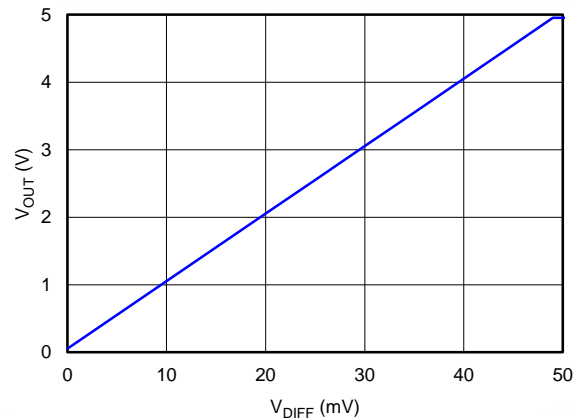

Figure 37. Instrumentation Amplifier Output Results

9.3 Do's and Don'ts

Do properly bypass the power supplies.

Do add series resistance to the output when driving capacitive loads, particularly cables, Muxes and ADC inputs.

Do add series current limiting resistors and external schottky clamp diodes if input voltage is expected to exceed the supplies. Limit the current to 1 mA or less (1 k Ω per volt).

10 Power Supply Recommendations

The LMV98x-N is specified for operation from 1.8 V to 5 V; many specifications apply from -40°C to 125°C . Parameters that can exhibit significant variance with regard to operating voltage or temperature are presented in [Typical Characteristics](#).

CAUTION

Supply voltages larger than 5.5 V can permanently damage the device; see [Absolute Maximum Ratings](#).

For proper operation, the power supplies must be properly decoupled. For decoupling the supply lines, TI recommends that 10-nF capacitors be placed as close as possible to the op amp power supply pins. For single-supply, place a capacitor between V^+ and V^- supply leads. For dual supplies, place one capacitor between V^+ and ground, and one capacitor between V^- and ground.

11 Layout

11.1 Layout Guidelines

The V^+ pin must be bypassed to ground with a low-ESR capacitor.

The optimum placement is closest to the V^+ and ground pins.

Take care to minimize the loop area formed by the bypass capacitor connection between V^+ and ground.

The ground pin must be connected to the PCB ground plane at the pin of the device.

The feedback components must be placed as close to the device as possible minimizing strays.

11.2 Layout Example

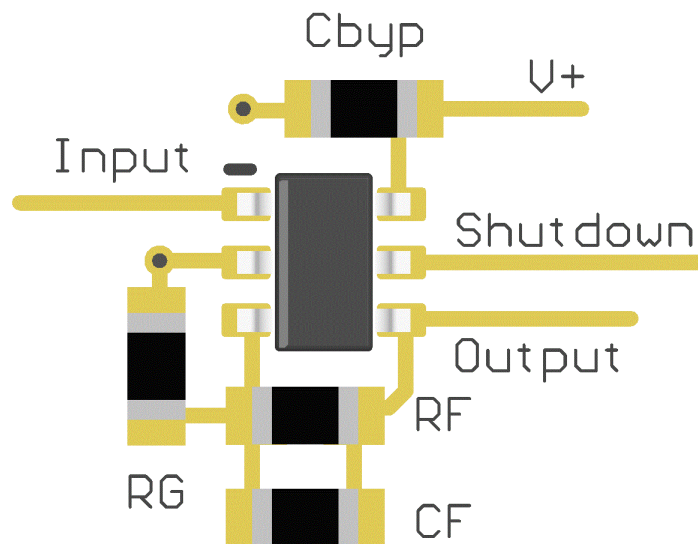

Figure 38. SOT-23 Layout Example

12 Device and Documentation Support

12.1 Documentation Support

12.1.1 Related Documentation

For related documentation see the following:

[Absolute Maximum Ratings for Soldering](#) (SNOA549)

12.2 Related Links

The table below lists quick access links. Categories include technical documents, support and community resources, tools and software, and quick access to sample or buy.

Table 1. Related Links

PARTS	PRODUCT FOLDER	SAMPLE & BUY	TECHNICAL DOCUMENTS	TOOLS & SOFTWARE	SUPPORT & COMMUNITY
LMV981-N	Click here	Click here	Click here	Click here	Click here
LMV982-N	Click here	Click here	Click here	Click here	Click here

12.3 Receiving Notification of Documentation Updates

To receive notification of documentation updates, navigate to the device product folder on ti.com. In the upper right corner, click on *Alert me* to register and receive a weekly digest of any product information that has changed. For change details, review the revision history included in any revised document.

12.4 Community Resources

The following links connect to TI community resources. Linked contents are provided "AS IS" by the respective contributors. They do not constitute TI specifications and do not necessarily reflect TI's views; see TI's [Terms of Use](#).

TI E2E™ Online Community *TI's Engineer-to-Engineer (E2E) Community*. Created to foster collaboration among engineers. At e2e.ti.com, you can ask questions, share knowledge, explore ideas and help solve problems with fellow engineers.

Design Support *TI's Design Support* Quickly find helpful E2E forums along with design support tools and contact information for technical support.

12.5 Trademarks

E2E is a trademark of Texas Instruments.
All other trademarks are the property of their respective owners.

12.6 Electrostatic Discharge Caution



These devices have limited built-in ESD protection. The leads should be shorted together or the device placed in conductive foam during storage or handling to prevent electrostatic damage to the MOS gates.

12.7 Glossary

[SLYZ022](#) — *TI Glossary*.

This glossary lists and explains terms, acronyms, and definitions.

13 Mechanical, Packaging, and Orderable Information

The following pages include mechanical, packaging, and orderable information. This information is the most current data available for the designated devices. This data is subject to change without notice and revision of this document. For browser-based versions of this data sheet, refer to the left-hand navigation.

PACKAGING INFORMATION

Orderable Device	Status (1)	Package Type	Package Drawing	Pins	Package Qty	Eco Plan (2)	Lead/Ball Finish (6)	MSL Peak Temp (3)	Op Temp (°C)	Device Marking (4/5)	Samples
LMV981MF	NRND	SOT-23	DBV	6	1000	TBD	Call TI	Call TI	-40 to 125	A78A	
LMV981MF/NOPB	ACTIVE	SOT-23	DBV	6	1000	Green (RoHS & no Sb/Br)	CU SN	Level-1-260C-UNLIM	-40 to 125	A78A	Samples
LMV981MFX/NOPB	ACTIVE	SOT-23	DBV	6	3000	Green (RoHS & no Sb/Br)	CU SN	Level-1-260C-UNLIM	-40 to 125	A78A	Samples
LMV981MG/NOPB	ACTIVE	SC70	DCK	6	1000	Green (RoHS & no Sb/Br)	CU SN	Level-1-260C-UNLIM	-40 to 125	A77	Samples
LMV981MGX/NOPB	ACTIVE	SC70	DCK	6	3000	Green (RoHS & no Sb/Br)	CU SN	Level-1-260C-UNLIM	-40 to 125	A77	Samples
LMV981TL/NOPB	ACTIVE	DSBGA	YZR	6	250	Green (RoHS & no Sb/Br)	SNAGCU	Level-1-260C-UNLIM	-40 to 125	A H	Samples
LMV981TLX/NOPB	ACTIVE	DSBGA	YZR	6	3000	Green (RoHS & no Sb/Br)	SNAGCU	Level-1-260C-UNLIM	-40 to 125	A H	Samples
LMV982MM/NOPB	ACTIVE	VSSOP	DGS	10	1000	Green (RoHS & no Sb/Br)	CU SN	Level-1-260C-UNLIM	-40 to 125	A87A	Samples
LMV982MMX/NOPB	ACTIVE	VSSOP	DGS	10	3500	Green (RoHS & no Sb/Br)	CU SN	Level-1-260C-UNLIM	-40 to 125	A87A	Samples

(1) The marketing status values are defined as follows:

ACTIVE: Product device recommended for new designs.

LIFEBUY: TI has announced that the device will be discontinued, and a lifetime-buy period is in effect.

NRND: Not recommended for new designs. Device is in production to support existing customers, but TI does not recommend using this part in a new design.

PREVIEW: Device has been announced but is not in production. Samples may or may not be available.

OBSELETE: TI has discontinued the production of the device.

(2) **RoHS:** TI defines "RoHS" to mean semiconductor products that are compliant with the current EU RoHS requirements for all 10 RoHS substances, including the requirement that RoHS substance do not exceed 0.1% by weight in homogeneous materials. Where designed to be soldered at high temperatures, "RoHS" products are suitable for use in specified lead-free processes. TI may reference these types of products as "Pb-Free".

RoHS Exempt: TI defines "RoHS Exempt" to mean products that contain lead but are compliant with EU RoHS pursuant to a specific EU RoHS exemption.

Green: TI defines "Green" to mean the content of Chlorine (Cl) and Bromine (Br) based flame retardants meet JS709B low halogen requirements of <=1000ppm threshold. Antimony trioxide based flame retardants must also meet the <=1000ppm threshold requirement.

(3) MSL, Peak Temp. - The Moisture Sensitivity Level rating according to the JEDEC industry standard classifications, and peak solder temperature.

(4) There may be additional marking, which relates to the logo, the lot trace code information, or the environmental category on the device.

⁽⁵⁾ Multiple Device Markings will be inside parentheses. Only one Device Marking contained in parentheses and separated by a "~" will appear on a device. If a line is indented then it is a continuation of the previous line and the two combined represent the entire Device Marking for that device.

⁽⁶⁾ Lead/Ball Finish - Orderable Devices may have multiple material finish options. Finish options are separated by a vertical ruled line. Lead/Ball Finish values may wrap to two lines if the finish value exceeds the maximum column width.

Important Information and Disclaimer:The information provided on this page represents TI's knowledge and belief as of the date that it is provided. TI bases its knowledge and belief on information provided by third parties, and makes no representation or warranty as to the accuracy of such information. Efforts are underway to better integrate information from third parties. TI has taken and continues to take reasonable steps to provide representative and accurate information but may not have conducted destructive testing or chemical analysis on incoming materials and chemicals. TI and TI suppliers consider certain information to be proprietary, and thus CAS numbers and other limited information may not be available for release.

In no event shall TI's liability arising out of such information exceed the total purchase price of the TI part(s) at issue in this document sold by TI to Customer on an annual basis.

TAPE AND REEL INFORMATION

QUADRANT ASSIGNMENTS FOR PIN 1 ORIENTATION IN TAPE

*All dimensions are nominal

Device	Package Type	Package Drawing	Pins	SPQ	Reel Diameter (mm)	Reel Width W1 (mm)	A0 (mm)	B0 (mm)	K0 (mm)	P1 (mm)	W (mm)	Pin1 Quadrant
LMV981MF	SOT-23	DBV	6	1000	178.0	8.4	3.2	3.2	1.4	4.0	8.0	Q3
LMV981MF/NOPB	SOT-23	DBV	6	1000	178.0	8.4	3.2	3.2	1.4	4.0	8.0	Q3
LMV981MFX/NOPB	SOT-23	DBV	6	3000	178.0	8.4	3.2	3.2	1.4	4.0	8.0	Q3
LMV981MG/NOPB	SC70	DCK	6	1000	178.0	8.4	2.25	2.45	1.2	4.0	8.0	Q3
LMV981MGX/NOPB	SC70	DCK	6	3000	178.0	8.4	2.25	2.45	1.2	4.0	8.0	Q3
LMV981TL/NOPB	DSBGA	YZR	6	250	178.0	8.4	1.12	1.63	0.76	4.0	8.0	Q1
LMV981TLX/NOPB	DSBGA	YZR	6	3000	178.0	8.4	1.12	1.63	0.76	4.0	8.0	Q1
LMV982MM/NOPB	VSSOP	DGS	10	1000	178.0	12.4	5.3	3.4	1.4	8.0	12.0	Q1
LMV982MMX/NOPB	VSSOP	DGS	10	3500	330.0	12.4	5.3	3.4	1.4	8.0	12.0	Q1

TAPE AND REEL BOX DIMENSIONS

*All dimensions are nominal

Device	Package Type	Package Drawing	Pins	SPQ	Length (mm)	Width (mm)	Height (mm)
LMV981MF	SOT-23	DBV	6	1000	210.0	185.0	35.0
LMV981MF/NOPB	SOT-23	DBV	6	1000	210.0	185.0	35.0
LMV981MFX/NOPB	SOT-23	DBV	6	3000	210.0	185.0	35.0
LMV981MG/NOPB	SC70	DCK	6	1000	210.0	185.0	35.0
LMV981MGX/NOPB	SC70	DCK	6	3000	210.0	185.0	35.0
LMV981TL/NOPB	DSBGA	YZR	6	250	210.0	185.0	35.0
LMV981TLX/NOPB	DSBGA	YZR	6	3000	210.0	185.0	35.0
LMV982MM/NOPB	VSSOP	DGS	10	1000	210.0	185.0	35.0
LMV982MMX/NOPB	VSSOP	DGS	10	3500	367.0	367.0	35.0

DBV0006A



PACKAGE OUTLINE

SOT-23 - 1.45 mm max height

SMALL OUTLINE TRANSISTOR



4214840/B 03/2018

NOTES:

1. All linear dimensions are in millimeters. Any dimensions in parenthesis are for reference only. Dimensioning and tolerancing per ASME Y14.5M.
2. This drawing is subject to change without notice.
3. Body dimensions do not include mold flash or protrusion. Mold flash and protrusion shall not exceed 0.15 per side.
4. Leads 1,2,3 may be wider than leads 4,5,6 for package orientation.
5. Reference JEDEC MO-178.

EXAMPLE BOARD LAYOUT

DBV0006A

SOT-23 - 1.45 mm max height

SMALL OUTLINE TRANSISTOR



LAND PATTERN EXAMPLE
EXPOSED METAL SHOWN
SCALE:15X



SOLDER MASK DETAILS

4214840/B 03/2018

NOTES: (continued)

6. Publication IPC-7351 may have alternate designs.

7. Solder mask tolerances between and around signal pads can vary based on board fabrication site.

EXAMPLE STENCIL DESIGN

DBV0006A

SOT-23 - 1.45 mm max height

SMALL OUTLINE TRANSISTOR



SOLDER PASTE EXAMPLE
BASED ON 0.125 mm THICK STENCIL
SCALE:15X

4214840/B 03/2018

NOTES: (continued)

8. Laser cutting apertures with trapezoidal walls and rounded corners may offer better paste release. IPC-7525 may have alternate design recommendations.
9. Board assembly site may have different recommendations for stencil design.

DGS0010A



PACKAGE OUTLINE

VSSOP - 1.1 mm max height

SMALL OUTLINE PACKAGE

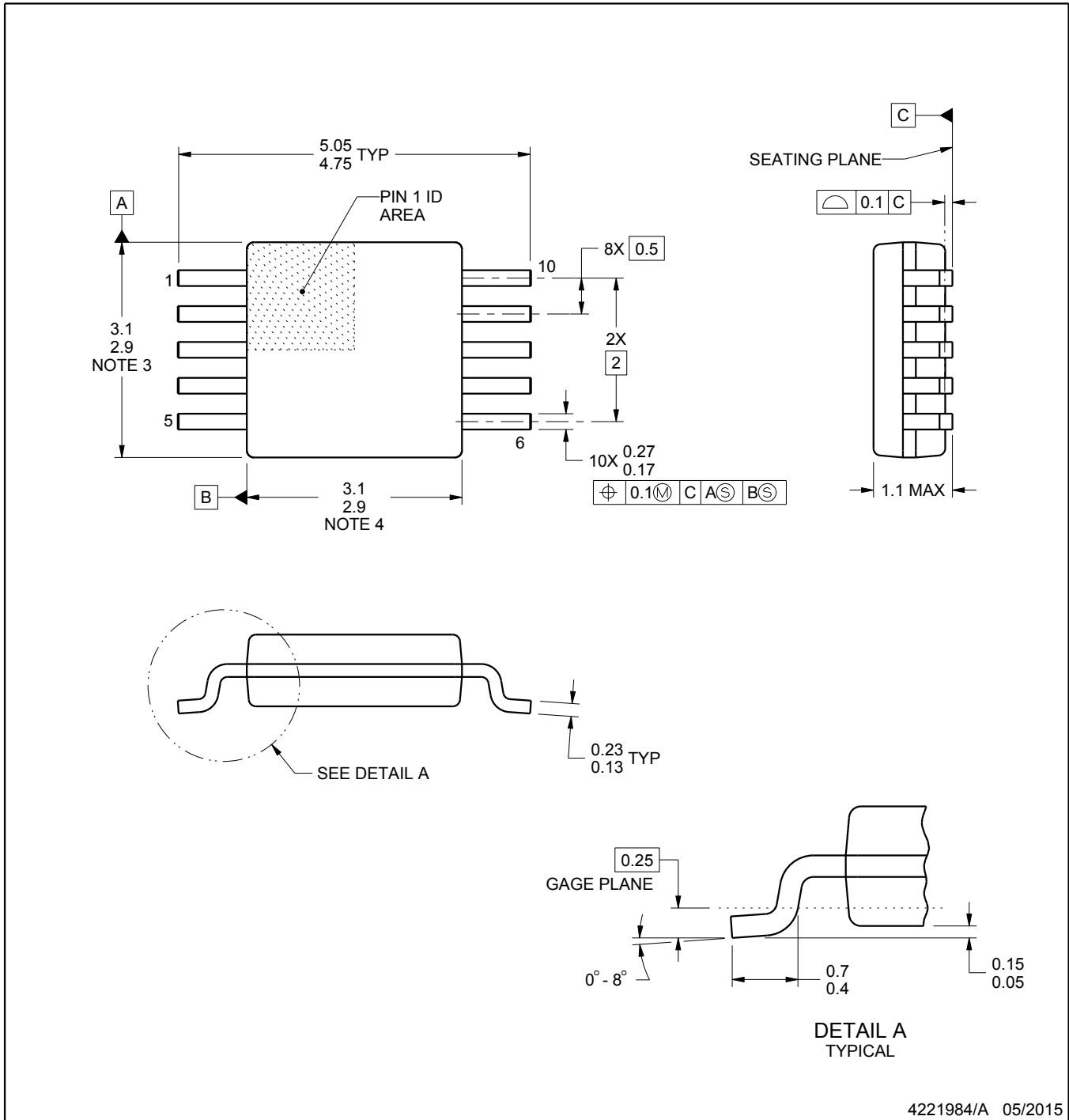

4221984/A 05/2015

NOTES:

1. All linear dimensions are in millimeters. Any dimensions in parenthesis are for reference only. Dimensioning and tolerancing per ASME Y14.5M.
2. This drawing is subject to change without notice.
3. This dimension does not include mold flash, protrusions, or gate burrs. Mold flash, protrusions, or gate burrs shall not exceed 0.15 mm per side.
4. This dimension does not include interlead flash. Interlead flash shall not exceed 0.25 mm per side.
5. Reference JEDEC registration MO-187, variation BA.

EXAMPLE BOARD LAYOUT

DGS0010A

VSSOP - 1.1 mm max height

SMALL OUTLINE PACKAGE



LAND PATTERN EXAMPLE
SCALE:10X

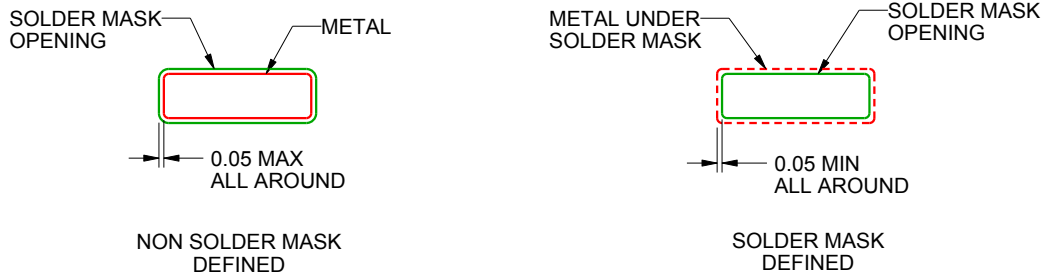

SOLDER MASK DETAILS
NOT TO SCALE

4221984/A 05/2015

NOTES: (continued)

- 6. Publication IPC-7351 may have alternate designs.
- 7. Solder mask tolerances between and around signal pads can vary based on board fabrication site.

EXAMPLE STENCIL DESIGN

DGS0010A

VSSOP - 1.1 mm max height

SMALL OUTLINE PACKAGE



SOLDER PASTE EXAMPLE
BASED ON 0.125 mm THICK STENCIL
SCALE:10X

4221984/A 05/2015

NOTES: (continued)

8. Laser cutting apertures with trapezoidal walls and rounded corners may offer better paste release. IPC-7525 may have alternate design recommendations.
9. Board assembly site may have different recommendations for stencil design.

DCK (R-PDSO-G6)

PLASTIC SMALL-OUTLINE PACKAGE

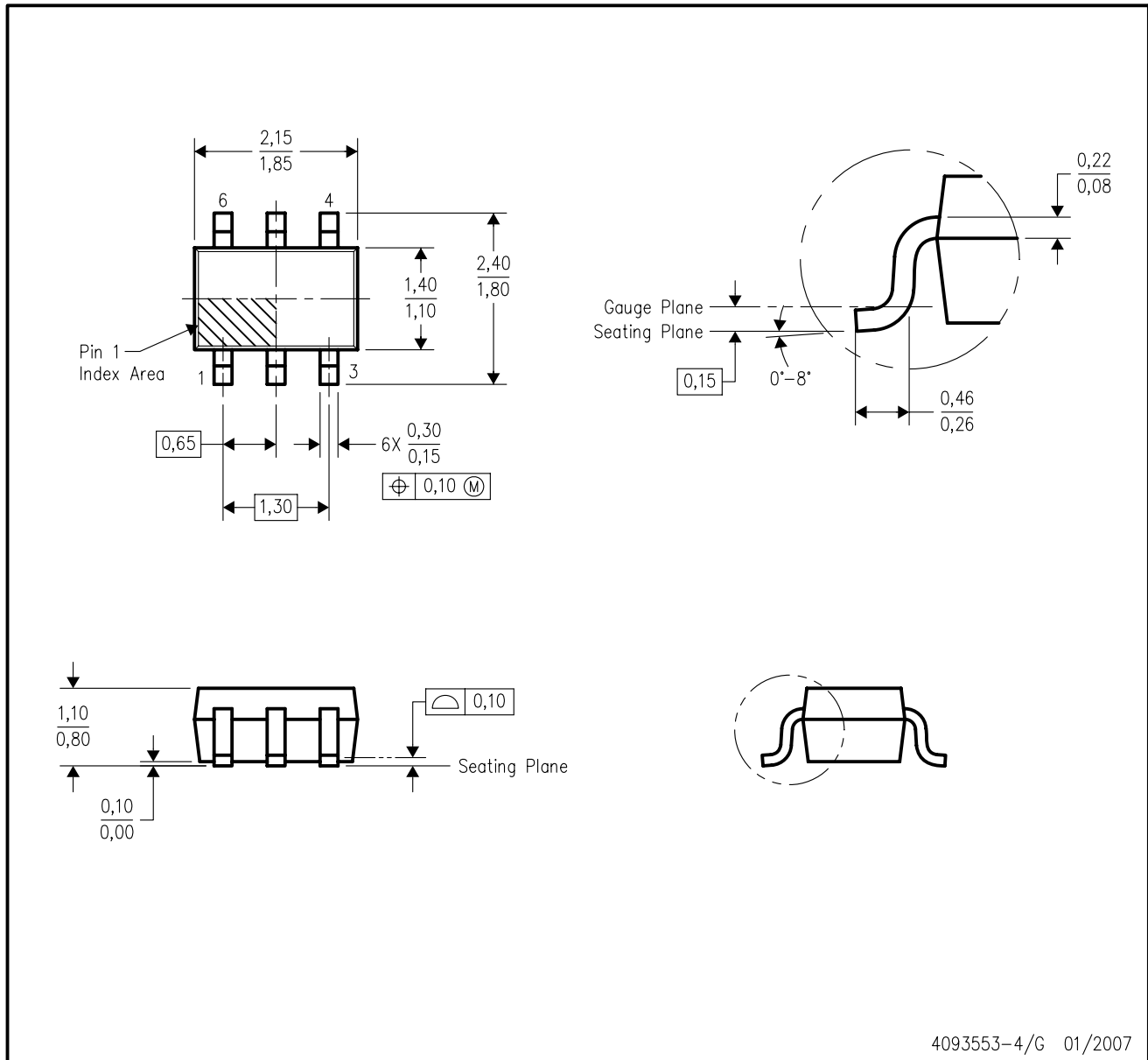

- NOTES:
- A. All linear dimensions are in millimeters.
 - B. This drawing is subject to change without notice.
 - C. Body dimensions do not include mold flash or protrusion. Mold flash and protrusion shall not exceed 0.15 per side.
 - D. Falls within JEDEC MO-203 variation AB.

DCK (R-PDSO-G6)

PLASTIC SMALL OUTLINE

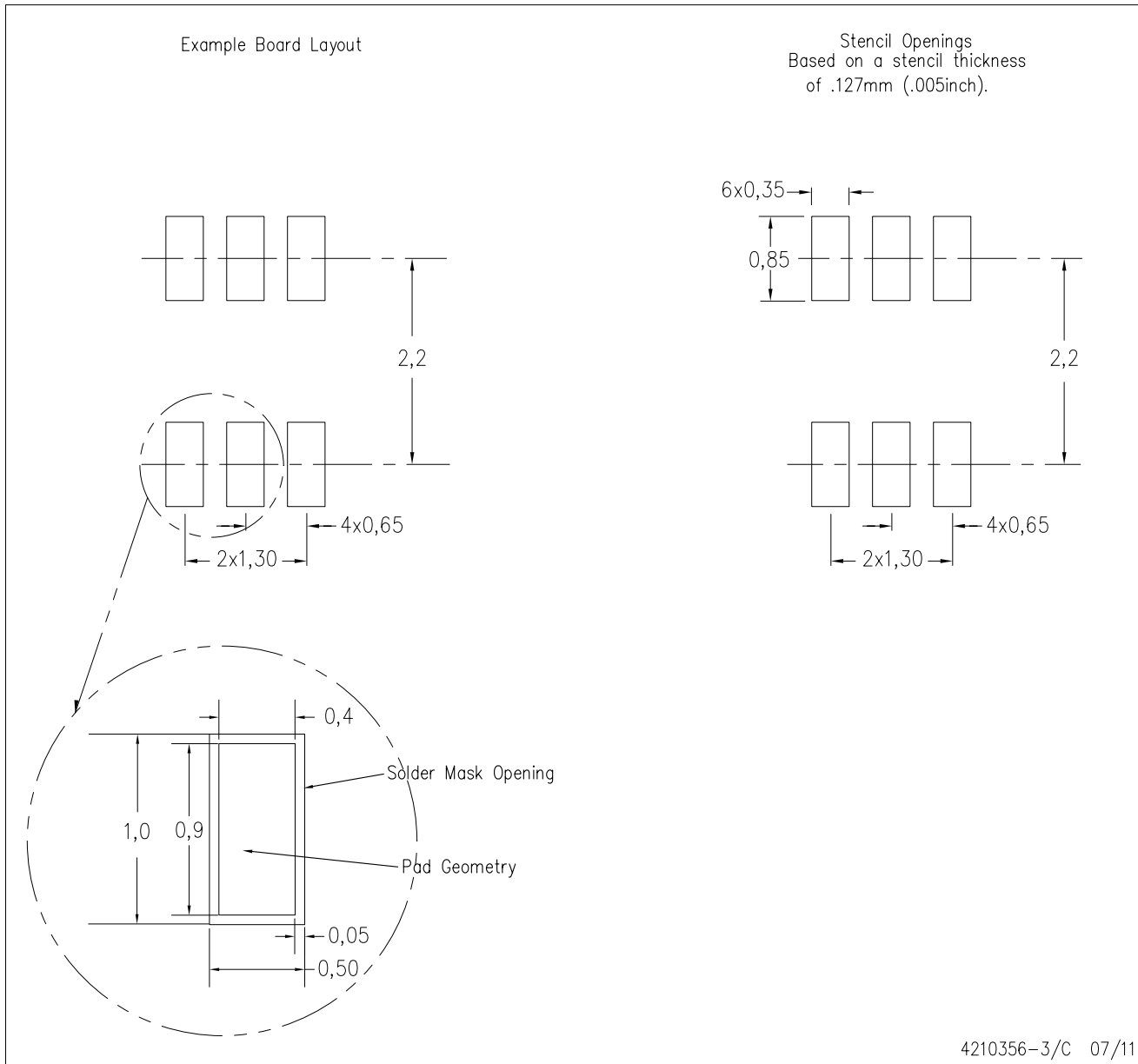

- NOTES:
- A. All linear dimensions are in millimeters.
 - B. This drawing is subject to change without notice.
 - C. Customers should place a note on the circuit board fabrication drawing not to alter the center solder mask defined pad.
 - D. Publication IPC-7351 is recommended for alternate designs.
 - E. Laser cutting apertures with trapezoidal walls and also rounding corners will offer better paste release. Customers should contact their board assembly site for stencil design recommendations. Example stencil design based on a 50% volumetric metal load solder paste. Refer to IPC-7525 for other stencil recommendations.

IMPORTANT NOTICE AND DISCLAIMER

TI PROVIDES TECHNICAL AND RELIABILITY DATA (INCLUDING DATASHEETS), DESIGN RESOURCES (INCLUDING REFERENCE DESIGNS), APPLICATION OR OTHER DESIGN ADVICE, WEB TOOLS, SAFETY INFORMATION, AND OTHER RESOURCES "AS IS" AND WITH ALL FAULTS, AND DISCLAIMS ALL WARRANTIES, EXPRESS AND IMPLIED, INCLUDING WITHOUT LIMITATION ANY IMPLIED WARRANTIES OF MERCHANTABILITY, FITNESS FOR A PARTICULAR PURPOSE OR NON-INFRINGEMENT OF THIRD PARTY INTELLECTUAL PROPERTY RIGHTS.

These resources are intended for skilled developers designing with TI products. You are solely responsible for (1) selecting the appropriate TI products for your application, (2) designing, validating and testing your application, and (3) ensuring your application meets applicable standards, and any other safety, security, or other requirements. These resources are subject to change without notice. TI grants you permission to use these resources only for development of an application that uses the TI products described in the resource. Other reproduction and display of these resources is prohibited. No license is granted to any other TI intellectual property right or to any third party intellectual property right. TI disclaims responsibility for, and you will fully indemnify TI and its representatives against, any claims, damages, costs, losses, and liabilities arising out of your use of these resources.

TI's products are provided subject to TI's Terms of Sale (www.ti.com/legal/termsofsale.html) or other applicable terms available either on ti.com or provided in conjunction with such TI products. TI's provision of these resources does not expand or otherwise alter TI's applicable warranties or warranty disclaimers for TI products.

Mailing Address: Texas Instruments, Post Office Box 655303, Dallas, Texas 75265
Copyright © 2019, Texas Instruments Incorporated

Looking for pricing, stock, or lifecycle information?

Click below to explore more details on WIN SOURCE:

 [View LMV981BLX on WIN SOURCE](#)

 [Texas Instruments](#) Information

Optimize Your Supply Chain with WIN SOURCE Solutions

-  Global Sourcing Solution
-  Obsolete Management
-  Cost Control Management
-  Shortage Management
-  Alternative Solution
-  Excess Inventory Management