



**THE DATASHEET OF  
ZRT025N8A1TA**



# 2.5V LOW POWER PRECISION REFERENCE SOURCE

ISSUE 1 - OCTOBER 1995

ZRT025

## DEVICE DESCRIPTION

The ZRT025 is a monolithic integrated circuit providing a precise stable reference voltage of 2.5V at 500 $\mu$ A.

The circuit features a knee current of 150 $\mu$ A and operation over a wide range of temperatures and currents.

The ZRT025 is available in a 3-pin metal can package for through hole applications as well as SOT223 and SO8 packages for surface mount applications. Each package option offers a trim facility whereby the output voltage can be adjusted as shown in Fig.1. This facility is used when compensating for system errors or setting the reference output to a particular value. When the trim facility is not used, the pin should be left open circuit.

## FEATURES

- Trimmable output
- Excellent temperature stability
- Low output noise figure
- Available in two temperature ranges
- 1 and 2% initial voltage tolerance versions available
- No external stabilising capacitor required in most cases
- Low slope resistance
- No derating required at low temperatures
- TO18 package
- SOT223 and SO8 small outline packages

## SCHEMATIC DIAGRAM

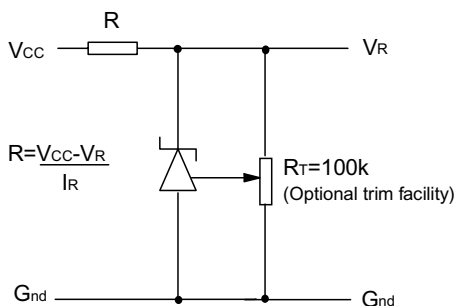

This circuit will allow the reference to be trimmed over a wide range. The device is specified over a  $\pm 5\%$  trim range.

# ZRT025

## ABSOLUTE MAXIMUM RATING

Reverse Current	75mA $\phi$
Operating Temperature	
A grade	-55°C to 125°C
C grade	0°C to 70°C
Storage Temperature	
TO18	-55 °C to 175 °C
SO8, SOT223	-55 °C to 125 °C

## Power Dissipation ( $T_{amb}=25^{\circ}\text{C}$ )

TO18	300mW
SO8	625mW
SOT223	2W
$\phi$ Above 72°C this figure should be linearly derated to 25mA at 125°C	

## TEMPERATURE DEPENDENT ELECTRICAL CHARACTERISTICS

SYMBOL	PARAMETER	INITIAL VOLTAGE TOLERANCE %	GRADE A -55°C TO 125°C		GRADE C 0°C TO 70°C		UNITS
			TYP	MAX	TYP	MAX	
$\Delta V_R$	Output voltage change over relevant temperature range (See note (a))	1 & 2	6.8	22.5	2.7	8.8	mV
$T_C V_R$	Output voltage temperature coefficient (See note (b))	1 & 2	15.0	50.0	15.0	50.0	ppm/°C

## ELECTRICAL CHARACTERISTICS

( at  $T_{amb}=25^{\circ}\text{C}$  and Trim pin o/c unless otherwise stated)

SYMBOL	PARAMETER	MIN.	TYP.	MAX.	UNITS	COMMENTS
$V_R$	Output voltage 1% tolerance (A1,C1) 2% tolerance (C2)	2.475 2.450	2.500 2.500	2.525 2.550	V	$I_R=500\mu\text{A}$
$\Delta V_{TRIM}$	Output voltage adjustment range		$\pm 5$		%	$R_T=100\text{k}\Omega$
$T_C \Delta V_{TRIM}$	Change in $T_C V_R$ with output adjustment		2.5		ppm/°C/%	
$I_R$	Operating current range	0.15		75	mA	
$t_{on}$ $t_{off}$	Turn-on time Turn-off time		10 0.3		$\mu\text{s}$	$R_L=1\text{k}\Omega$
$e_{np-p}$	Output voltage noise (over the range 0.1 to 10Hz)		50		$\mu\text{V}$	Peak to peak measurement
$R_S$	Slope resistance		0.85	2.0	$\Omega$	$I_R= 0.5\text{mA}$ to 5mA See note (c)

## TYPICAL CHARACTERISTICS

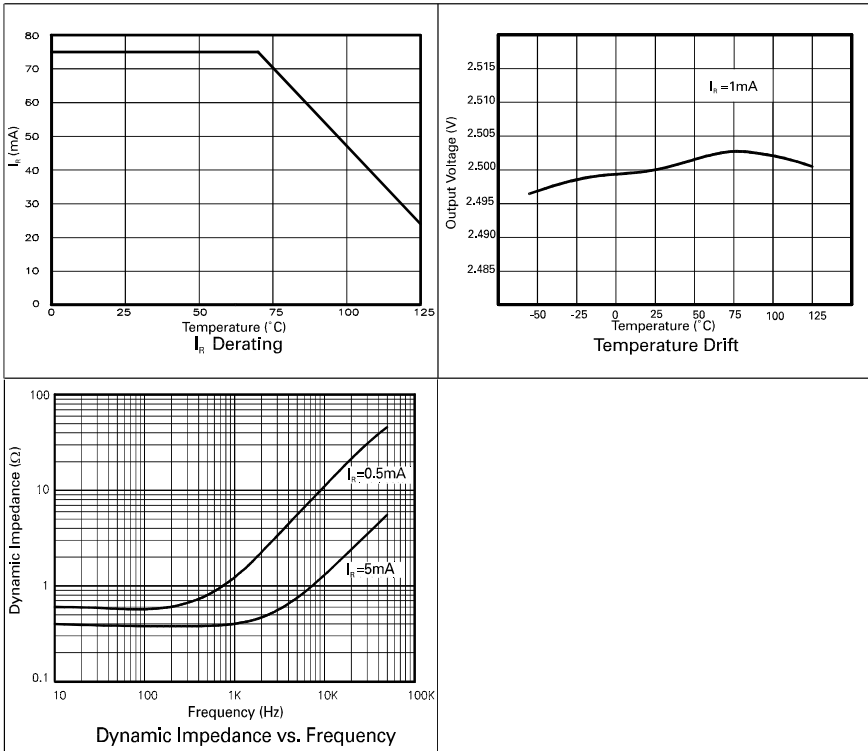

### NOTES

#### (a) Output change with temperature

The absolute maximum difference between the maximum output voltage and the minimum output voltage over the specified temperature range

$$\Delta V_R = V_{max} - V_{min}$$

#### (b) Output temperature coefficient ( $T_c V_R$ )

The ratio of the output change with temperature to the specified temperature range expressed in ppm/ $^{\circ}$ C

$$T_c V_R = \frac{\Delta V_R \times 10^6}{V_R \times \Delta T} \text{ ppm}/^{\circ}\text{C}$$

$\Delta T$  = Full temperature range

#### (c) Slope resistance ( $R_S$ )

The slope resistance is defined as :

$$R_S = \frac{\text{change in } V_R}{\text{specified current range}}$$

$$\Delta I = 5 - 0.5 = 4.5\text{mA (typically)}$$

#### (d) Line regulation

The ratio of change in output voltage to the change in input voltage producing it.

$$\frac{R_S \times 100}{V_R \times R_{source}} \% / V$$

# ZRT025

## CONNECTION DIAGRAMS

### SOT223 Package Suffix – G

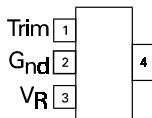

*Top View*  
Pin 4 floating or connected to pin 2

### TO18 Package Suffix – None

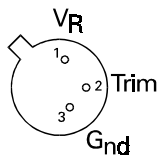

*Bottom View –*  
Case is internally connected to pin 3

### SO8 Package Suffix – N8

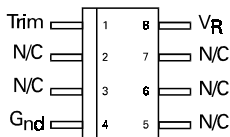



*Top View*

## ORDERING INFORMATION







Part No	Tol%	Operating Temp.(°C)	Package	Partmark
ZRT025C2	2	0 to 70	TO18	ZRT025C2
ZRT025C1	1	0 to 70	TO18	ZRT025C1
ZRT025A1	1	-55 to 125	TO18	ZRT025A1
ZRT025GC2	2	0 to 70	SOT223	ZRT025C2
ZRT025GC1	1	0 to 70	SOT223	ZRT025C1
ZRT025GA1	1	-55 to 125	SOT223	ZRT025A1
ZRT025N8C2	2	0 to 70	SO8	ZRT025C2
ZRT025N8C1	1	0 to 70	SO8	ZRT025C1
ZRT025N8A1	1	-55 to 125	SO8	ZRT025A1

# Looking for pricing, stock, or lifecycle information?

Click below to explore more details on WIN SOURCE:

-  [View ZRT025N8A1TA on WIN SOURCE](#)
-  [Diodes Incorporated Information](#)

## Optimize Your Supply Chain with WIN SOURCE Solutions

-  Global Sourcing Solution
-  Obsolete Management
-  Cost Control Management
-  Shortage Management
-  Alternative Solution
-  Excess Inventory Management