



**THE DATASHEET OF
LTC1682IMS8-5#PBF**



FEATURES

- Low Output Noise: $60\mu\text{V}_{\text{RMS}}$ (100kHz BW)
- Adjustable or Fixed Boosted Output
- Adjustable Output Voltage Range: 2.5V to 5.5V
- Fixed Output Voltages: 3.3V, 5V
- Wide Input Voltage Range: 1.8V to 4.4V
- Uses Small Ceramic Capacitors
- No Inductors Required
- Output Current up to 50mA
- 550kHz Switching Frequency
- Low Operating Current: 150 μA
- Low Shutdown Current: 1 μA
- Internal Thermal Shutdown and Current Limiting
- Available in 8-Pin MSOP and SO Packages

APPLICATIONS

- VCO Power Supplies in Cellular Phones
- 2-Way Pagers
- Wireless PCMCIA Cards
- Portable Medical Instruments
- Low Power Data Acquisition
- Remote Transmitters

DESCRIPTION

The LTC[®]1682/LTC1682-3.3/LTC1682-5 are doubler charge pumps with an internal low noise, low dropout (LDO) linear regulator. These parts are designed to provide a low noise boosted supply voltage for powering noise sensitive devices such as high frequency VCOs in wireless applications.

An internal doubler charge pump converts a 1.8V to 4.4V input to a boosted output, while the internal LDO regulator converts the boosted voltage to a low noise regulated output. The adjustable version allows the user to set V_{OUT} via external resistors connected to FB. The regulator is capable of supplying up to 50mA of output current. Shutdown reduces the supply current to < 5 μA , removes the load from V_{IN} by disabling the regulator and discharges V_{OUT} to ground through a 100 Ω switch.

The LTC1682 LDO regulator is stable with only 2 μF on the output. Small ceramic capacitors can be used, reducing PC board area.

The LTC1682/LTC1682-3.3/LTC1682-5 are short-circuit and over temperature protected. The parts are available in 8-pin MSOP and SO packages.

 LTC and LT are registered trademarks of Linear Technology Corporation.

TYPICAL APPLICATION

4.2V VCO Power Supply, $V_{\text{IN}} = 2.5\text{V to }4.4\text{V}$

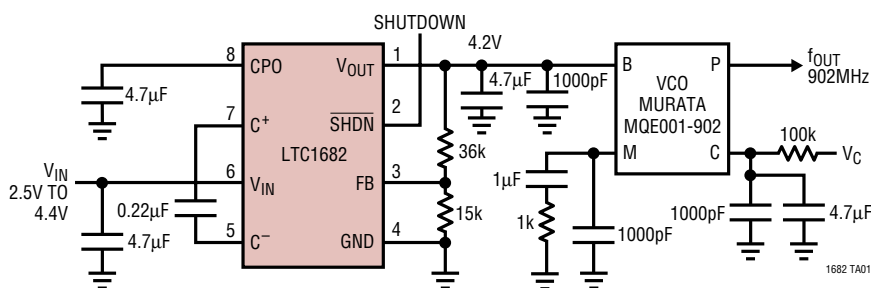

Open-Loop Close-In Phase Noise

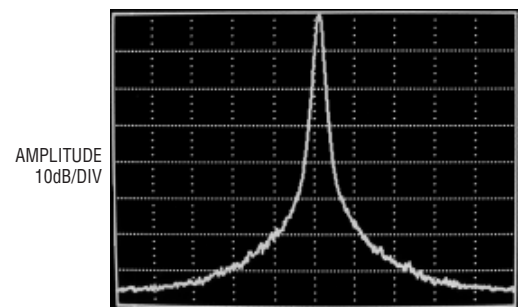

CENTER = 902MHz
 SPAN = 100kHz
 SWP = 10 sec
 RES BW = 1kHz
 VBW = 30Hz
 REF = 0dBm

1682 TA02

LTC1682/LTC1682-3.3/LTC1682-5

ABSOLUTE MAXIMUM RATINGS (Note 1)

V_{IN} to Ground	-0.3V to 5V	Operating Temperature Range	
V_{OUT} Voltage	-0.3V to 6V	Commercial	0°C to 70°C
CPO to Ground	10V	Extended Commercial (Note 2)	-40°C to 85°C
\overline{SHDN} , FILT/FB Voltage to		Industrial	-40°C to 85°C
Ground	-0.3V to ($V_{IN} + 0.3V$)	Storage Temperature Range	-65°C to 150°C
V_{OUT} Short-Circuit Duration	Indefinite	Lead Temperature (Soldering, 10 sec)	300°C
I_{OUT}	90mA	Maximum Junction Temperature	125°C

PACKAGE/ORDER INFORMATION

<p>MS8 PACKAGE 8-LEAD PLASTIC MSOP</p> <p>*PIN3 = FILT FOR LTC1682-3.3/LTC1682-5 = FB FOR LTC1682</p> <p>$T_{JMAX} = 125^{\circ}C$, $\theta_{JA} = 140^{\circ}C/W$</p>	ORDER PART NUMBER	<p>S8 PACKAGE 8-LEAD PLASTIC SO</p> <p>*PIN3 = FILT FOR LTC1682-3.3/LTC1682-5 = FB FOR LTC1682</p> <p>$T_{JMAX} = 125^{\circ}C$, $\theta_{JA} = 120^{\circ}C/W$</p>	ORDER PART NUMBER
	LTC1682CMS8 LTC1682CMS8-3.3 LTC1682CMS8-5 LTC1682IMS8 LTC1682IMS8-3.3 LTC1682IMS8-5		LTC1682CS8 LTC1682CS8-3.3 LTC1682CS8-5 LTC1682IS8 LTC1682IS8-3.3 LTC1682IS8-5
	MS8 PART MARKING		S8 PART MARKING
	LTER LTHM LTGT LTGU LTGV LTGW		1682 1682I 168233 1682I33 16825 1682I5

Consult factory for Military grade parts.

ELECTRICAL CHARACTERISTICS

The ● denotes specifications that apply over the full operating temperature range, otherwise specifications are $T_A = 25^{\circ}C$. $\overline{SHDN} = V_{IN} = 3V$; $C1 = 0.22\mu F$; $C2, C3, C4 = 4.7\mu F$, unless otherwise noted.

PARAMETER	CONDITIONS	MIN	TYP	MAX	UNITS
V_{IN} Operating Voltage	LTC1682 ● LTC1682-3.3 ● LTC1682-5 ●	1.8 2 2.7		4.4 4.4 4.4	V
I_{VIN} Shutdown Current	$\overline{SHDN} = 0V$ ●		1	5	μA
I_{VIN} Operating Current	$I_{OUT} = 0mA$, Burst Mode™ Operation 0°C to 70°C ● -40°C to 85°C ●		150 150	250 300	μA μA
FB Input Current	LTC1682, FB = 1.235V ●	-50		50	nA
FB Voltage	LTC1682 ●	1.210	1.235	1.260	V
Regulated Output Voltage	LTC1682-3.3, $I_{OUT} = 1mA$ ● LTC1682-5, $I_{OUT} = 1mA$ ●	3.23 4.9	3.30 5.0	3.37 5.1	V V
V_{OUT} Temperature Coefficient			±50		ppm
Charge Pump Oscillator Frequency	$I_{OUT} > 200\mu A$, $V_{IN} = 1.8V$ to 4.4V ●	480	550	620	kHz

Burst Mode is a trademark of Linear Technology Corporation.

ELECTRICAL CHARACTERISTICS

The ● denotes specifications that apply over the full operating temperature range, otherwise specifications are $T_A = 25^\circ\text{C}$. $\overline{\text{SHDN}} = V_{\text{IN}} = 3\text{V}$; $\text{C1} = 0.22\mu\text{F}$; $\text{C2}, \text{C3}, \text{C4} = 4.7\mu\text{F}$, unless otherwise noted.

PARAMETER	CONDITIONS		MIN	TYP	MAX	UNITS
CPO (Charge Pump Output) Output Resistance	$V_{\text{IN}} = 1.8\text{V}$, $I_{\text{OUT}} = 10\text{mA}$	●		18	30	Ω
	$V_{\text{IN}} = 3\text{V}$, $I_{\text{OUT}} = 10\text{mA}$	●		13	20	Ω
	$V_{\text{IN}} = 4.4\text{V}$, $I_{\text{OUT}} = 10\text{mA}$	●		11	17	Ω
V_{OUT} Dropout Voltage (Note 3)	LTC1682, $I_{\text{OUT}} = 10\text{mA}$, $V_{\text{OUT}} = 2.57\text{V}$ (Note 5)	●		100	160	mV
	LTC1682/LTC1682-3.3, $I_{\text{OUT}} = 10\text{mA}$, $V_{\text{OUT}} = 3.3\text{V}$	●		75	120	mV
	LTC1682/LTC1682-5, $I_{\text{OUT}} = 10\text{mA}$, $V_{\text{OUT}} = 5\text{V}$	●		50	90	mV
V_{OUT} Enable Time	$I_{\text{OUT}} = 10\text{mA}$			2		ms
V_{OUT} Output Noise Voltage	LTC1682	$I_{\text{OUT}} = 10\text{mA}$, $10\text{Hz} \leq f \leq 100\text{kHz}$, $V_{\text{OUT}} = 5\text{V}$ $I_{\text{OUT}} = 10\text{mA}$, $10\text{Hz} \leq f \leq 2.5\text{MHz}$, $V_{\text{OUT}} = 5\text{V}$		88 800		μV_{RMS} $\mu\text{V}_{\text{P-P}}$
	LTC1682-3.3	$I_{\text{OUT}} = 10\text{mA}$, $10\text{Hz} \leq f \leq 100\text{kHz}$, $C_{\text{FILT}} = 1\text{nF}$ $I_{\text{OUT}} = 10\text{mA}$, $10\text{Hz} \leq f \leq 2.5\text{MHz}$, $C_{\text{FILT}} = 1\text{nF}$		58 500		μV_{RMS} $\mu\text{V}_{\text{P-P}}$
	LTC1682-5	$I_{\text{OUT}} = 10\text{mA}$, $10\text{Hz} \leq f \leq 100\text{kHz}$, $C_{\text{FILT}} = 1\text{nF}$ $I_{\text{OUT}} = 10\text{mA}$, $10\text{Hz} \leq f \leq 2.5\text{MHz}$, $C_{\text{FILT}} = 1\text{nF}$		64 600		μV_{RMS} $\mu\text{V}_{\text{P-P}}$
V_{OUT} Line Regulation	$V_{\text{IN}} = 3\text{V}$ to 4V , $I_{\text{OUT}} = 0\text{mA}$ (Note 6)	●		5	20	mV
V_{OUT} Load Regulation	$I_{\text{OUT}} = 1\text{mA}$ to 10mA	●		3	10	mV
	$I_{\text{OUT}} = 1\text{mA}$ to 50mA (Note 4)			10		mV
V_{OUT} Shutdown Resistance	$\overline{\text{SHDN}} = 0\text{V}$, Resistance Measured to Ground, $V_{\text{IN}} = 1.8\text{V}$	●		150	350	Ω
	$\overline{\text{SHDN}} = 0\text{V}$, Resistance Measured to Ground, $V_{\text{IN}} = 4.4\text{V}$	●		50	150	Ω
$\overline{\text{SHDN}}$ Input Threshold	$V_{\text{IN}} = 1.8\text{V}$ to 4.4V	●	0.4	1	1.6	V
$\overline{\text{SHDN}}$ Input Current	$\overline{\text{SHDN}} = V_{\text{IN}}$	●	-1		1	μA
	$\overline{\text{SHDN}} = 0\text{V}$	●	-1		1	μA

Note 1: Absolute Maximum Ratings are those values beyond which the life of a device may be impaired.

Note 2: The LTC1682C is guaranteed to meet specified performance from 0°C to 70°C and is designed, characterized and expected to meet these extended temperature limits, but is not tested at -40°C and 85°C . The LTC1682I is guaranteed to meet the extended temperature limits.

Note 3: Dropout voltage is the minimum input/output voltage required to maintain regulation at the specified output current. In dropout the output voltage will be equal to: $V_{\text{CPO}} - V_{\text{DROPOUT}}$ (see Figure 4).

Note 4: Operating conditions are limited by maximum junction temperature. The regulated output specification will not apply for all possible combinations of input voltage and output current. When operating at maximum input voltage, the output current range may be limited. When operating at maximum output current, the input voltage range may be limited.

Note 5: Limited by the LDO disable switch point of $1.45V_{\text{IN}}$.

Note 6: The LTC1682 is set to 5V . The feedback current is $25\mu\text{A}$.

TYPICAL PERFORMANCE CHARACTERISTICS

CPO Output Resistance vs V_{IN}

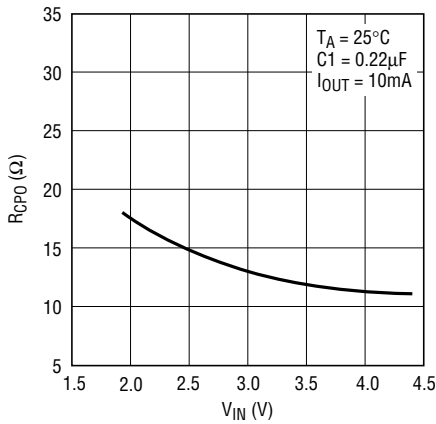

1682 G01

Min and Max V_{CPO} vs V_{IN}

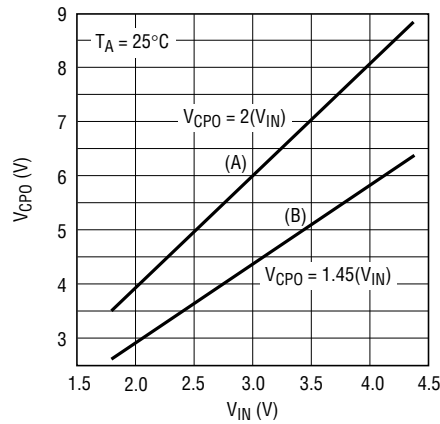

- (A) THE MAXIMUM GENERATED NO LOAD CPO VOLTAGE
- (B) THE MINIMUM ALLOWABLE CPO VOLTAGE, AT FULL LOAD, TO ENSURE THAT THE LDO IS NOT DISABLED

1682 G02

V_{OUT} Transient Response

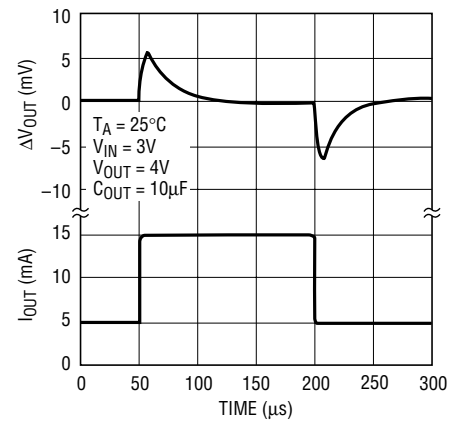

1682 G02

LTC1682-5 Output Noise (BW = 10Hz to 2.5MHz)

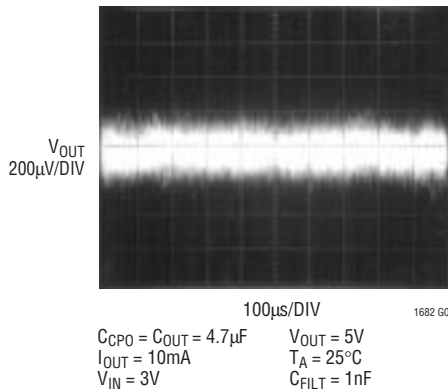

1682 G04

Shutdown to Enable Timing

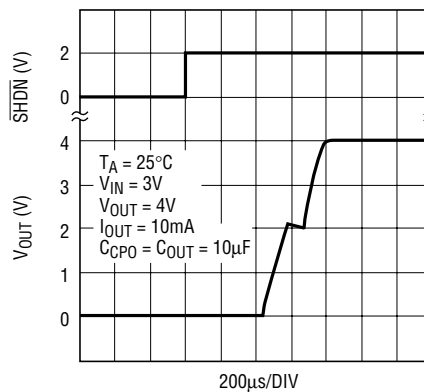

1682 G05

Enable to Shutdown Timing

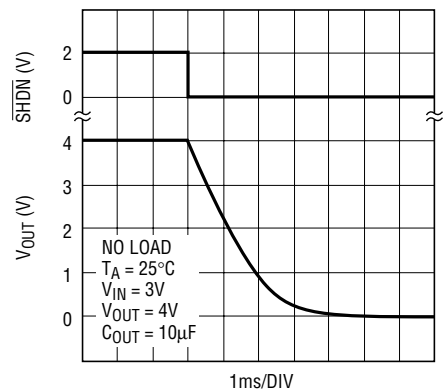

1682 G06

Oscillator Frequency vs Temperature

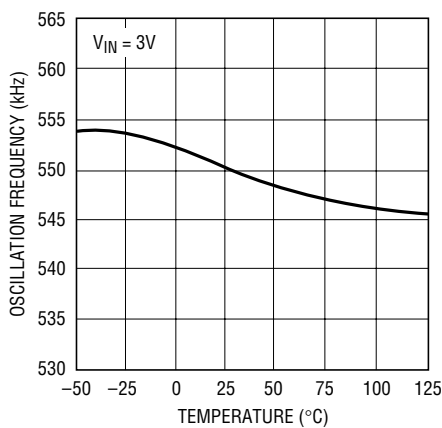

1682 G07

Operating Current vs V_{IN} (No Load)

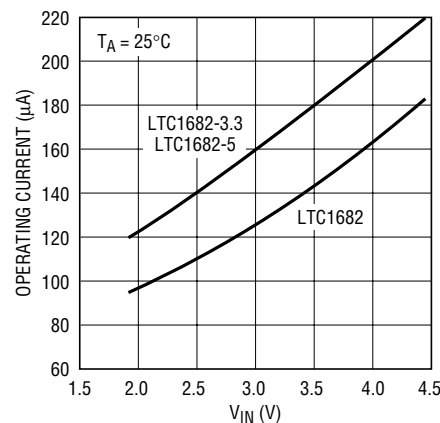

1682 G08

TYPICAL PERFORMANCE CHARACTERISTICS

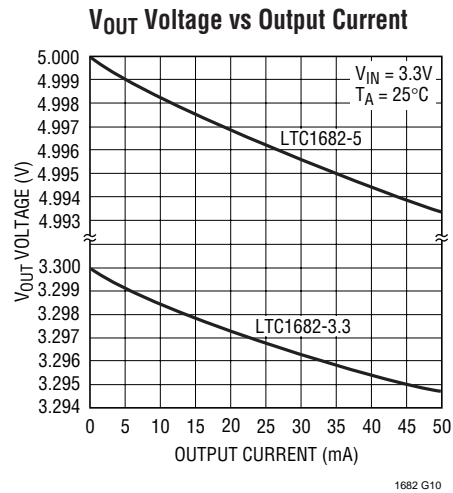
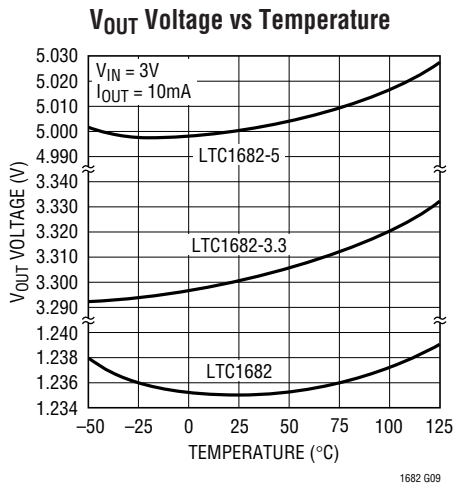

PIN FUNCTIONS

V_{OUT} (Pin 1): Low Noise Regulated Output Voltage. V_{OUT} should be bypassed with a $\geq 2\mu F$ low ESR capacitor as close to the pin as possible for best performance. The V_{OUT} range is 2.5V to 5.5V.

SHDN (Pin 2): Shutdown Input. A logic low on the SHDN pin puts the part in shutdown mode. A logic high enables the part. To continuously enable the part connect SHDN to V_{IN}. When the part is in shutdown, V_{OUT} will be connected to ground via a 100 Ω switch and CPO will be high impedance disconnected from V_{IN}.

FB (Pin 3) (LTC1682): The voltage on this pin is compared to the internal reference voltage (1.235V) by the error amplifier to keep the output in regulation. An external resistor divider is required between V_{OUT} and FB to adjust the output voltage.

FILT (Pin 3) (LTC1682-3.3/LTC1682-5): This pin is used to filter the internal voltage reference. Typically a 1nF capacitor is connected from FILT to ground.

GND (Pin 4): System Ground.

C⁻ (Pin 5): Flying Capacitor Negative Input.

V_{IN} (Pin 6): Input Voltage, 1.8V to 4.4V. V_{IN} should be bypassed with a $\geq 2\mu F$ low ESR capacitor as close to the pin as possible for best performance. A minimum capacitance value of 0.1 μF is required.

C⁺ (Pin 7): Flying Capacitor Positive Input.

CPO (Pin 8): Unregulated Charge Pump Output Voltage. Approximately 1.95(V_{IN}) at low loads. Bypass with a $\geq 2\mu F$ low ESR capacitor. If a minimum V_{OUT} enable time is required, the CPO capacitor should be 2 \times the V_{OUT} capacitor.

BLOCK DIAGRAMS

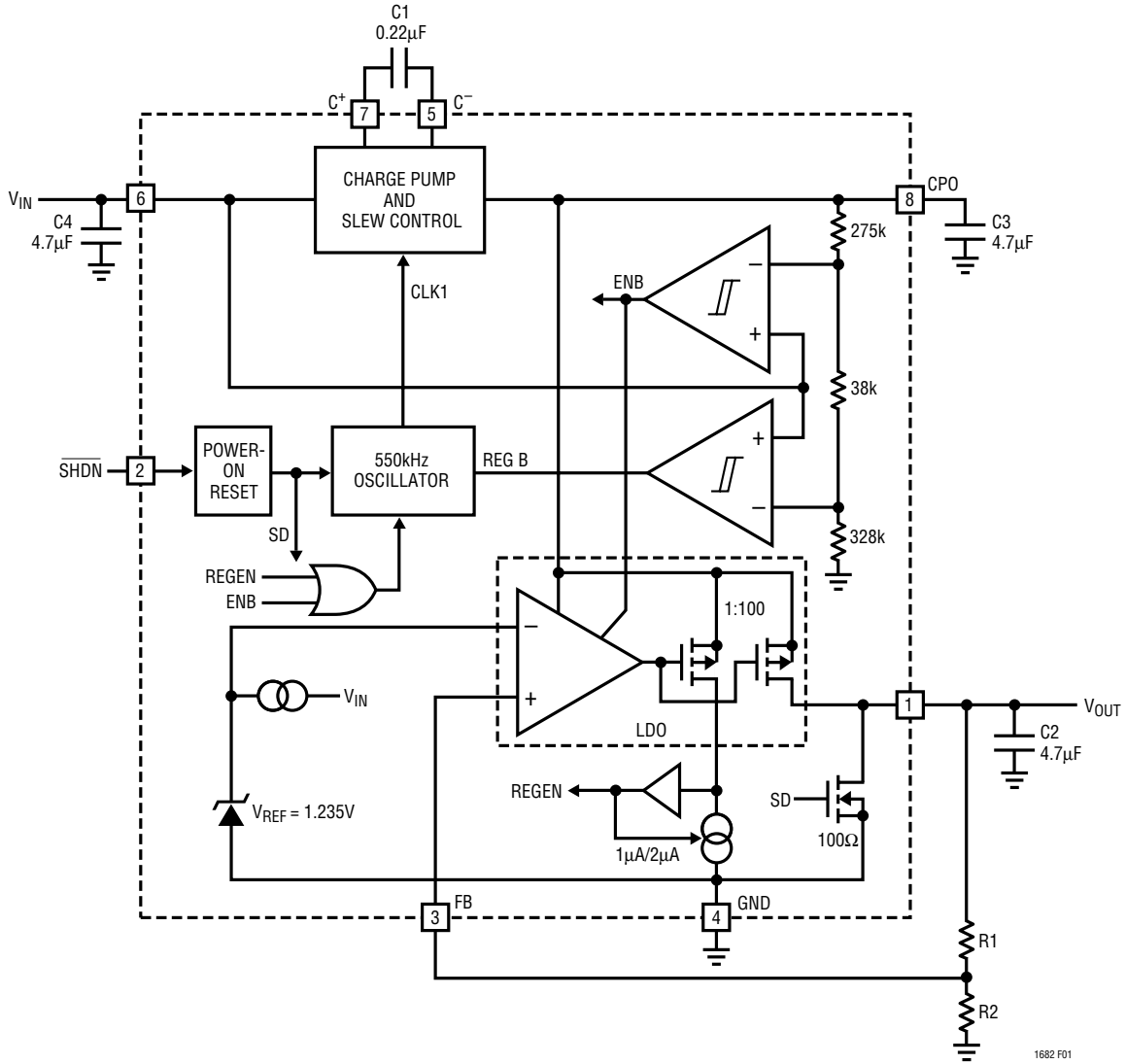

Figure 1. LTC1682 Block Diagram

BLOCK DIAGRAMS

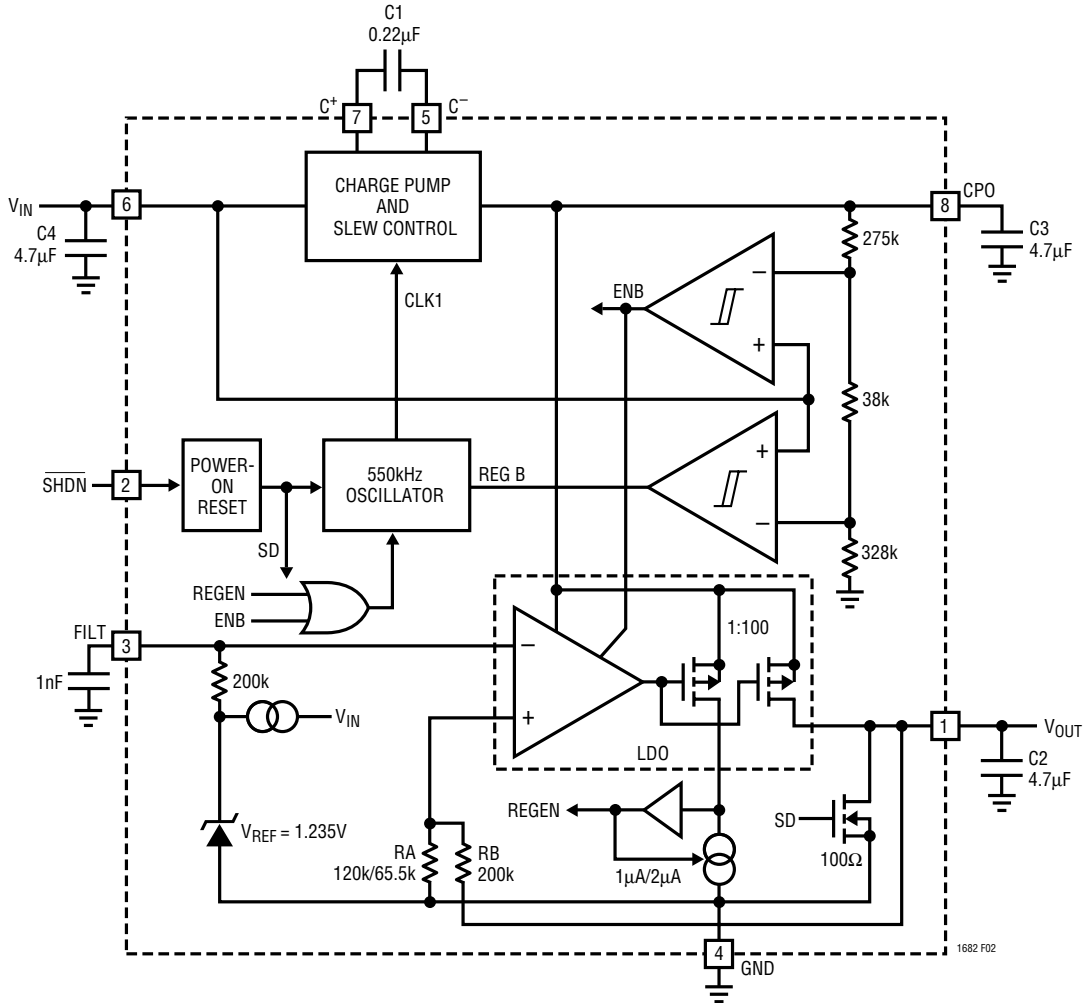

Figure 2. LTC1682-3.3/LTC1682-5 Block Diagram

APPLICATIONS INFORMATION

Operation

The LTC1682 uses a switched-capacitor charge pump to generate a CPO voltage of approximately $2(V_{IN})$. CPO powers an internal low dropout linear regulator that supplies a regulated output at V_{OUT} . Internal comparators are used to sense CPO and V_{IN} voltages for power-up conditioning. The output current is sensed to determine the charge pump operating mode. A trimmed internal bandgap is used as the voltage reference and a trimmed internal oscillator is used to control the charge pump switches.

The charge pump is a doubler configuration that uses one external flying capacitor. When enabled, a 2-phase nonoverlapping clock controls the charge pump switches. At start-up, the LDO is disabled and the load is removed from CPO. When CPO reaches $1.75(V_{IN})$ the LDO is enabled. If CPO falls below $1.45(V_{IN})$ the LDO will be disabled. Generally, the charge pump runs open loop with continuous clocking for low noise. If CPO is greater than $1.95(V_{IN})$ and I_{OUT} is less than $100\mu A$, the charge pump will operate in Burst Mode operation for increased efficiency but slightly higher output noise. In Burst Mode operation, the clock is disabled when CPO reaches $1.95(V_{IN})$ and enabled when CPO droops by about $100mV$. The switching frequency is precisely controlled to ensure that the frequency is above $455kHz$ and at the optimum rate to ensure maximum efficiency. The switch edge rates are also controlled to minimize noise. The effective output resistance at CPO is dependent on the voltage at V_{IN} , CPO and the junction temperature. A low ESR capacitor of $\geq 2\mu F$ should be used at CPO for minimum noise.

The LDO is used to filter the ripple on CPO and to set an output voltage independent of CPO. V_{OUT} is set by an external or internal resistor divider. The LDO requires a capacitor on V_{OUT} for stability and improved load transient response. A low ESR capacitor of $\geq 2\mu F$ should be used.

Output Voltage Selection

The LTC1682-3.3/LTC1682-5 versions have internal resistor networks to set the regulated output voltage. The LTC1682 output voltage is set using an external resistor divider (see Figure 3). The output voltage is determined using the following formula:

$$V_{OUT} = 1.235V(1 + R1/R2)$$

The output voltage range is 2.5V to 5.5V.

Maximum V_{OUT} and I_{OUT} Calculations

The maximum available output voltage and current can be calculated based on the open circuit CPO voltage, the dropout voltage of the LDO and the effective output resistance of the charge pump. The open circuit CPO voltage is approximately $2(V_{IN})$ (see Figure 4).

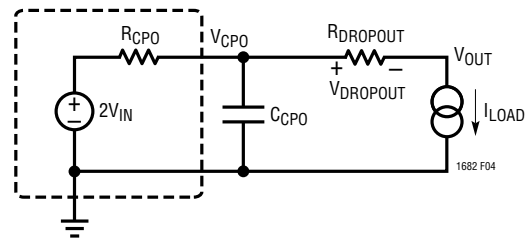

Figure 4. Equivalent Circuit

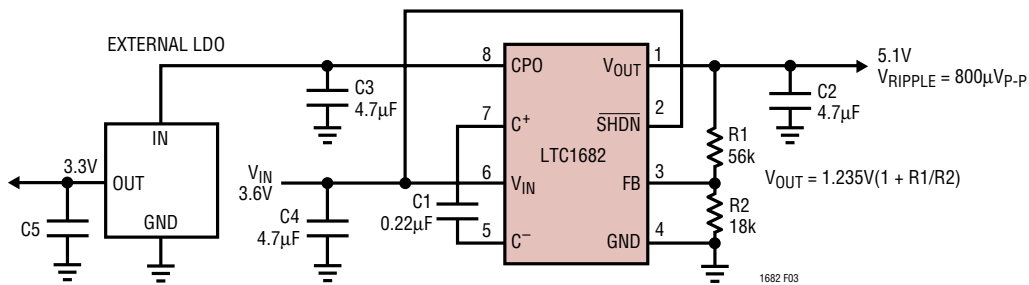

Figure 3. Powering an Auxiliary Regulator from CPO

APPLICATIONS INFORMATION

The following formula can be used to find the maximum output voltage that may be programmed for a given minimum input voltage and output current load:

$$V_{OUT(MAX)} = (2)(V_{IN(MIN)}) - (I_{OUT})(R_{CPO}) - V_{DROPOUT}$$

with the condition that $(I_{OUT})(R_{CPO}) < 0.55V_{IN}$.

Example:

$$V_{IN(MIN)} = 3V$$

$$I_{OUT} = 10mA$$

$$R_{CPO(MAX)} = 20\Omega$$

$$\text{Max unloaded CPO voltage} = 6V$$

$$\text{Loaded CPO voltage} = 6V - (10mA)(20\Omega) = 5.8V$$

$$V_{DROPOUT(MAX)} = 0.08V$$

$$V_{OUT(MAX)} = (6V) - (0.2V) - (0.08V) = 5.72V$$

$$V_{OUT} < 5.5V \text{ and } (I_{OUT})(R_{CPO}) < 0.55V_{IN}, 0.2V < 1.65V.$$

For minimum noise applications, the LDO must be kept out of dropout to prevent CPO noise from coupling into V_{OUT} .

External CPO Loading

The CPO output can drive an external load (an LDO, for example). The current required by this additional load will reduce the available current from V_{OUT} . If the external load requires 5mA, then the maximum available current at V_{OUT} will be reduced by 5mA.

Short-Circuit and Thermal Protection

V_{OUT} can be shorted to ground indefinitely. Internal circuitry will limit the output current. If the junction temperature exceeds 150°C, the part will shut down. Excessive power dissipation due to heavy loads will also cause the part to shut down when the junction temperature exceeds 150°C. The part will become enabled when the junction temperature drops below 140°C. If the fault condition remains in place, the part will cycle between the shutdown and enabled states.

Capacitor Selection

For best performance it is recommended that low ESR capacitors be used for C2, C3 and C4 in Figure 1 to reduce noise and ripple. C2 must be $\geq 2\mu F$ and C3 must be equal to or greater than C2. C4 is dependent on the source impedance. The charge pump demands large

instantaneous currents which may induce ripple onto a common voltage rail. C4 should be $\geq 2\mu F$ and a spike reducing resistor of 2.2 Ω may be required between V_{IN} and the supply.

A low ESR ceramic capacitor is recommended for the flying capacitor C1 with a value of 0.22 μF . At low load or high V_{IN} a smaller capacitor could be used to reduce ripple on CPO which would reflect as lower ripple on V_{OUT} .

If a minimum enable time is required, the CPO output filter capacitor should be at least 2 \times the V_{OUT} filter capacitor. When the LDO is first enabled, the CPO capacitor will dump a large amount of charge into the V_{OUT} capacitor. If the drop in the CPO voltage falls below 1.45(V_{IN}), the LDO will be disabled and the CPO voltage will have to charge up to 1.75(V_{IN}) to enable the LDO. The resulting cycling extends the enable time.

A 1nF filter capacitor for the LTC1682-3.3/LTC1682-5 should be connected between the FILT pin and ground for optimum noise performance.

Output Ripple

The output noise and ripple on CPO includes a spike component from the charge pump switches and a droop component which is dependent on the load current and the value of C3. The charge pump has been carefully designed to minimize the spike component; however, low ESR capacitors are essential to reduce the remaining spike energy effect on the CPO voltage. C3 should be increased for high load currents to minimize the droop component. Ripple components on CPO are greatly reduced at V_{OUT} by the LDO; however, C2 should also be a low ESR capacitor to improve filtering of the CPO noise.

Shutdown

When \overline{SHDN} pin is pulled low ($< 0.4V$), the part will be in shutdown, the supply current will be $< 5\mu A$ and V_{OUT} will be connected to ground through a 100 Ω switch. In addition, CPO will be high impedance and disconnected from V_{IN} .

If shutdown is not required, connect \overline{SHDN} to V_{IN} which will continuously enable the part.

APPLICATIONS INFORMATION

Power-On Reset

Upon initial power-up, a power-on reset circuit ensures that the internal functions are correctly initialized when power is applied. Once V_{IN} reaches approximately 1V, the power-on reset circuit will enable the part as long as the SHDN pin is held high.

Thermal Considerations

The power handling capability of the device will be limited by the maximum rated junction temperature (125°C). The device power dissipation $P_D = I_{OUT}(2V_{IN} - V_{OUT}) + V_{IN}(4mA)$. The device dissipates the majority of its heat through its pins, especially GND (Pin 4). Thermal resistance to ambient can be optimized by connecting GND to a large copper region on the PCB, which serves as a heat sink. Applications which operate the LTC1682 near maximum power levels should maximize the copper area at all pins except C^+ , C^- and FILT/FB and ensure that there is some airflow over the part to carry away excess heat.

General Layout Considerations

Due to the high switching frequency and high transient currents produced by the device, careful board layout is a must. A clean board layout using a ground plane and short connections to all capacitors will improve noise performance and ensure proper regulation (Figure 5).

The FILT pin on the LTC1682-3.3/LTC1682-5 is a high impedance node. Leakage currents at this pin must be minimized.

Measuring Output Noise

Measuring the LTC1682 low noise levels requires care. Figure 6 shows a test setup for taking the measurement. Good connection and signal handling technique should yield about 500 μ V_{P-P} over a 2.5MHz bandwidth. The noise measurement involves AC coupling the LTC1682 output into the test setup's input and terminating this connection with 50 Ω . Coaxial connections must be maintained to preserve measurement integrity.

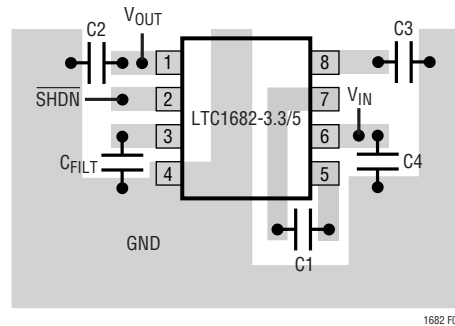

Figure 5

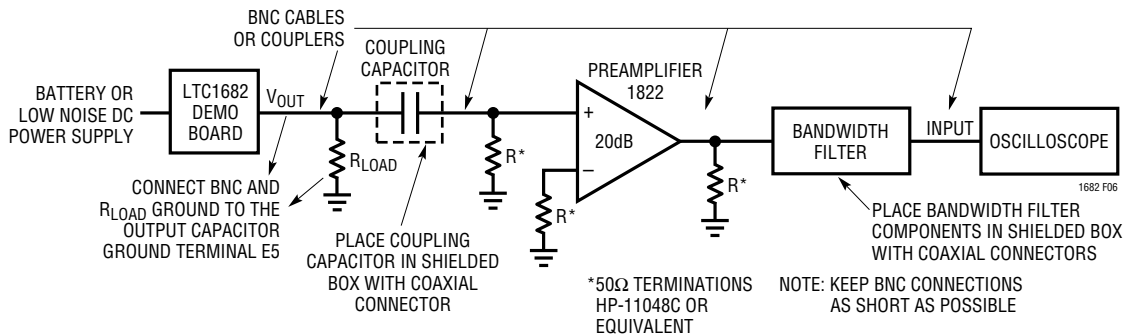
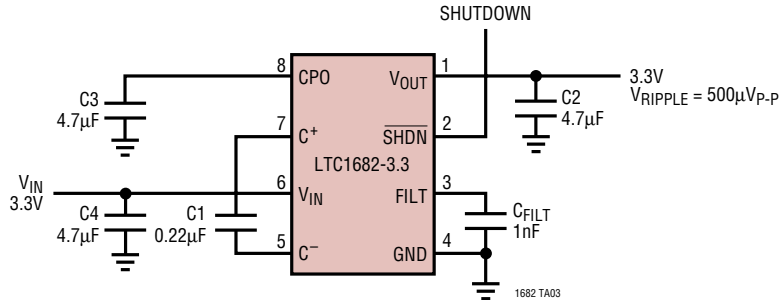

Figure 6. LTC1682 Noise Measurement Test Setup

TYPICAL APPLICATION

3.3V to Low Noise 3.3V Converter



PACKAGE DESCRIPTION

Dimensions in inches (millimeters) unless otherwise noted.

MS8 Package
8-Lead Plastic MSOP
(LTC DWG # 05-08-1660)

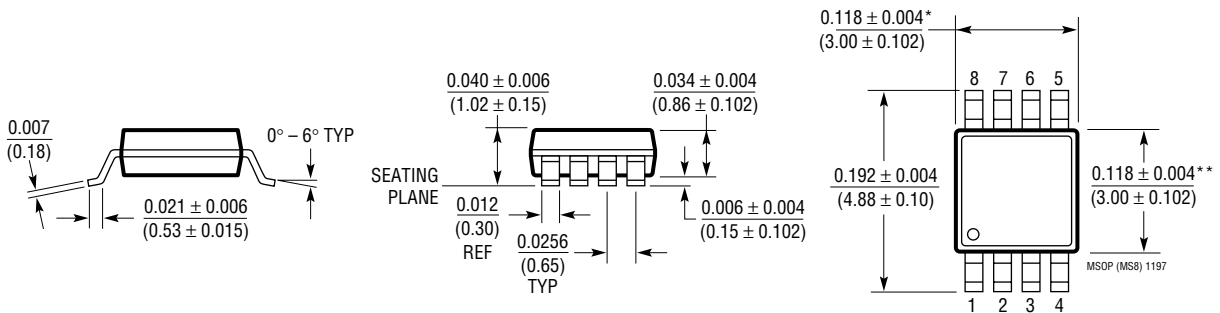

* DIMENSION DOES NOT INCLUDE MOLD FLASH, PROTRUSIONS OR GATE BURRS. MOLD FLASH, PROTRUSIONS OR GATE BURRS SHALL NOT EXCEED 0.006" (0.152mm) PER SIDE
 ** DIMENSION DOES NOT INCLUDE INTERLEAD FLASH OR PROTRUSIONS. INTERLEAD FLASH OR PROTRUSIONS SHALL NOT EXCEED 0.006" (0.152mm) PER SIDE

S8 Package
8-Lead Plastic Small Outline (Narrow 0.150)
(LTC DWG # 05-08-1610)

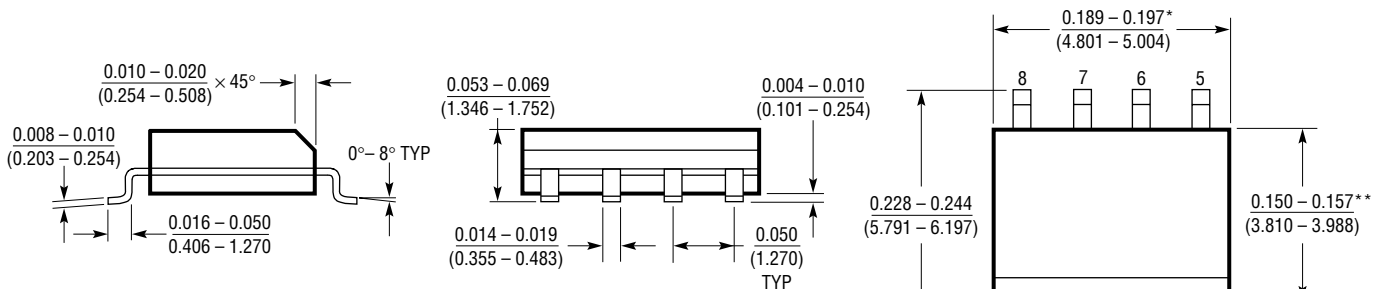

* DIMENSION DOES NOT INCLUDE MOLD FLASH. MOLD FLASH SHALL NOT EXCEED 0.006" (0.152mm) PER SIDE
 ** DIMENSION DOES NOT INCLUDE INTERLEAD FLASH. INTERLEAD FLASH SHALL NOT EXCEED 0.010" (0.254mm) PER SIDE

TYPICAL APPLICATION

Wide Input Range VCO Supply ($V_{IN} > 4.4V$)

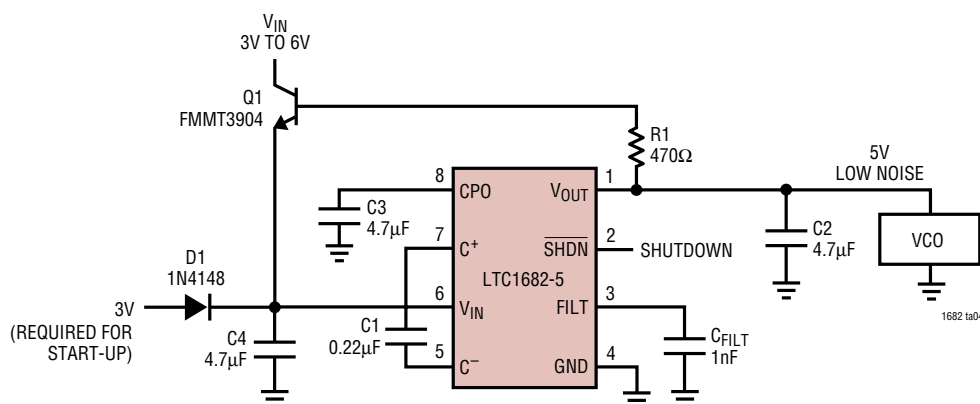

RELATED PARTS

PART NUMBER	DESCRIPTION	COMMENTS
LTC1340	Low Noise, Voltage-Boosted Varactor Driver	Generates 5V Varactor Drive from 3V Supply
LTC1517-X	Micropower, Regulated Charge Pump Doubler in SOT-23	$I_{CC} = 6\mu A$; Short Circuit/Thermal Protected
LT1521	300mA Low Dropout Regulator	Micropower; Good Transient Response
LTC1522	Micropower, Regulated 5V Charge Pump	Ultralow Power: Typical Operating $I_{CC} = 6\mu A$
LT1761 Series	100mA Low Noise LDO Regulator in SOT-23	$I_{CC} = 20\mu A$; $20\mu V_{RMS}$ Output Noise

Looking for pricing, stock, or lifecycle information?

Click below to explore more details on WIN SOURCE:

- ⊖ [View LTC1682IMS8-5#PBF on WIN SOURCE](#)
- ⊖ [Linear Technology Information](#)

Optimize Your Supply Chain with WIN SOURCE Solutions

- ✓ Global Sourcing Solution
- ✓ Obsolete Management
- ✓ Cost Control Management
- ✓ Shortage Management
- ✓ Alternative Solution
- ✓ Excess Inventory Management