

TOSHIBA Photocoupler GaAlAs Ired & Photo IC

TLP2530, TLP2531

Digital Logic Isolation
 Line Receiver
 Power Supply Control
 Switching Power Supply
 Industrial Inverter

The TOSHIBA TLP2530 and TLP2531 dual photocouplers consist of a pair of GaAlAs light emitting diode and integrated photodetector. This unit is 8-lead DIP. Separate connection for the photodiode bias and output transistor collectors improve the speed up to a hundred times that of a conventional phototransistor coupler by reducing the base-collector capacitance.

- TTL compatible
- Switching speed: $t_{pHL} = 0.2 \mu s$, $t_{pLH} = 0.3 \mu s$ (typ.)
 (@ $R_L = 1.9 k\Omega$)
- Guaranteed performance over temp: $0^\circ C$ to $70^\circ C$
- Isolation voltage: 2500 Vrms (min)
- UL approved: UL1577, file no. E67349
- c-UL approved : CSA Component Acceptance Service
 No. 5A, File No.E67349

Unit: mm

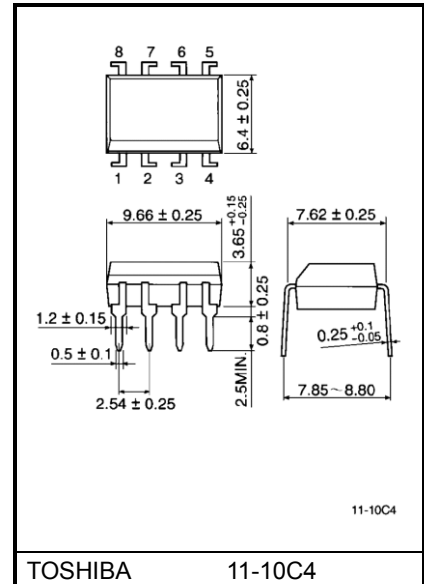

Weight: 0.54 g (typ.)

Pin Configuration (top view)

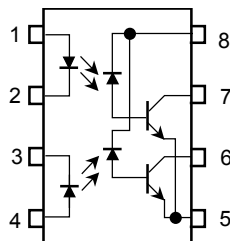

- 1. : Anode.1
- 2. : Cathode.1
- 3. : Cathode.2
- 4. : Anode.2
- 5. : $\bar{G}ND$
- 6. : V_{O2} (output 2)
- 7. : V_{O1} (output 1)
- 8. : V_{CC}

Schematic

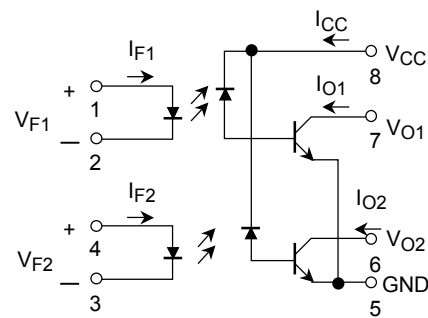

Start of commercial production
 1986-03

Absolute Maximum Ratings (Ta = 25°C)

Characteristic		Symbol	Rating	Unit
LED	Forward current (each channel)	I _F	25	mA
	Forward current derating (each channel) (Ta > 70 °C)	ΔI _F /Ta	-0.8	mA / °C
	Pulse forward current (each channel) (Note 1)	I _{FP}	50	mA
	Pulse forward current derating (each channel) (Ta > 70 °C)	ΔI _{FP} /Ta	-1.6	mA / °C
	Total pulse forward current (each channel) (Note 2)	I _{FPT}	1	A
	Reverse voltage (each channel)	V _R	5	V
	Diode power dissipation (each channel)	P _D	45	mW
	Diode power dissipation derating (each channel) (Ta > 70 °C)	ΔP _D /Ta	-0.8	mW / °C
Detector	Output current (each channel)	I _O	8	mA
	Peak output current (each channel)	I _{OP}	16	mA
	Output voltage (each channel)	V _O	-0.5 to 15	V
	Supply voltage	V _{CC}	-0.5 to 15	V
	Output power dissipation (each channel)	P _O	35	mW
	Output power dissipation derating (each channel) (Ta > 70 °C)	ΔP _O /Ta	-0.6	mW / °C
Operating temperature range		T _{opr}	-55 to 100	°C
Storage temperature range		T _{stg}	-55 to 125	°C
Lead solder temperature (10 s) (Note 3)		T _{sol}	260	°C
Isolation voltage (AC, 60 s, R.H. ≤ 60%) (Note 4)		BV _S	2500	V _{rms}

Note: Using continuously under heavy loads (e.g. the application of high temperature/current/voltage and the significant change in temperature, etc.) may cause this product to decrease in the reliability significantly even if the operating conditions (i.e. operating temperature/current/voltage, etc.) are within the absolute maximum ratings.

Please design the appropriate reliability upon reviewing the Toshiba Semiconductor Reliability Handbook ("Handling Precautions"/"Derating Concept and Methods") and individual reliability data (i.e. reliability test report and estimated failure rate, etc).

Note 1: 50% duty cycle, 1ms pulse width.

Note 2: Pulse width ≤ 1 μs, 300 pps.

Note 3: 2mm below seating plane.

Note 4: Device considered a two-terminal device: Pins 1, 2, 3 and 4 shorted together and pins 5, 6, 7 and 8 shorted together.

Recommended Operating Conditions

Characteristic	Symbol	Min	Typ.	Max	Unit
Supply voltage	V _{CC}	0	—	12	V
Forward current (each channel)	I _F	—	16	25	mA
Operating temperature	T _{opr}	-25	—	85	°C

Note: Recommended operating conditions are given as a design guideline to obtain expected performance of the device. Additionally, each item is an independent guideline respectively. In developing designs using this product, please confirm specified characteristics shown in this document.

Electrical Characteristics (Ta = 0°C to 70°C, unless otherwise noted)

Characteristic		Symbol	Test Condition	Min	Typ.	Max	Unit
Input forward voltage (each channel)		V _F	I _F = 16mA, Ta = 25°C	—	1.65	1.7	V
Temperature coefficient of forward voltage (each channel)		ΔV _F / ΔTa	I _F = 16mA	—	-2	—	mV/°C
Input reverse breakdown voltage (each channel)		BV _R	I _R = 10μA, Ta = 25°C	5	—	—	V
Input capacitance (each channel)		C _T	f = 1MHz, V _F = 0 V	—	45	—	pF
Logic high output current (each channel)		I _{OH}	I _F = 0mA, V _O = V _{CC} = 5.5V Ta = 25°C	—	3	500	nA
			I _F = 0mA, V _O = V _{CC} = 15V	—	—	50	μA
Logic low supply current		I _{CCL}	I _{F1} = I _{F2} = 16mA V _{O1} = V _{O2} = Open V _{CC} = 15V	—	160	—	μA
Logic high supply current		I _{CCH}	I _{F1} = I _{F2} = 0mA V _{O1} = V _{O2} = Open V _{CC} = 15V	—	0.05	4	μA
Current transfer ratio (each channel)	TLP2530	I _O / I _F	I _F = 16mA, V _O = 0.4V V _{CC} = 4.5V, Ta = 25°C	7	30	—	%
	TLP2531			19	30	—	
	TLP2530	I _O / I _F	I _F = 16mA, V _O = 0.4V V _{CC} = 4.5V	5	—	—	%
	TLP2531			15	—	—	
Logic low output voltage (each channel)		V _{OL}	I _F = 16mA, I _O = 1.1mA V _{CC} = 4.5V	—	0.1	0.4	V
			I _F = 16mA, I _O = 2.4mA V _{CC} = 4.5V	—	0.1	0.4	V
Resistance (input-output)		R _S	V _S = 500 V R.H. ≤ 60% (Note 1)	5×10 ¹⁰	10 ¹⁴	—	Ω
Capacitance (input-output)		C _S	f = 1MHz (Note 1)	—	0.6	—	pF
Resistance (input-input)		R _{I-I}	V _{I-I} = 500V (Note 1)	—	10 ¹¹	—	Ω
Capacitance (input-iutput)		C _{I-I}	f = 1MHz (Note 1)	—	0.25	—	pF

Note: All typicals at Ta = 25°C.

Note 1: Device considered a two-terminal device: Pins 1, 2, 3 and 4 shorted together and pins 5, 6, 7 and 8 shorted together.

Switching Characteristics (unless otherwise specified, Ta = 25°C, Vcc = 5V, If = 16mA)

Characteristic		Symbol	Test Circuit	Test Condition	Min	Typ.	Max	Unit
Propagation delay time to logic low at output (each channel)	TLP2530	tpHL	1	RL = 4.1kΩ	—	0.3	1.5	μs
	TLP2531			RL = 1.9kΩ	—	0.2	0.8	
Propagation delay time to logic high at output (each channel)	TLP2530	tpLH	1	RL = 4.1kΩ	—	0.5	1.5	μs
	TLP2531			RL = 1.9kΩ	—	0.3	0.8	
Common mode transient immunity at logic high level output (each channel) (Note 1)	TLP2530	CMH	2	VCM = 400Vp-p RL = 4.1kΩ, IF = 0mA	—	1500	—	V / μs
	TLP2531			VCM = 400Vp-p RL = 1.9kΩ, IF = 0mA	—	1500	—	
Common mode transient immunity at logic low level output (each channel) (Note 1)	TLP2530	CML	2	VCM = 400Vp-p RL = 4.1kΩ, IF = 16mA	—	-1500	—	V / μs
	TLP2531			VCM = 400Vp-p RL = 1.9kΩ, IF = 16mA	—	-1500	—	
Bandwidth (each channel)		BW	3	RL = 100Ω	—	2	—	MHz

Note 1: Common mode transient immunity in logic high level is the maximum tolerable (positive) dV_{cm} / dt on the leading edge of the common mode pulse, V_{cm} , to assure that the output will remain in a logic high state (i.e., $V_O > 2.0V$).
Common mode transient immunity in logic low level is the maximum tolerable (negative) dV_{cm} / dt on the trailing edge of the common mode pulse signal, V_{cm} , to assure that the output will remain in logic low state (i.e., $V_O < 0.8V$).

Test Circuit 1: Switching Time, t_{pHL} , t_{pLH}

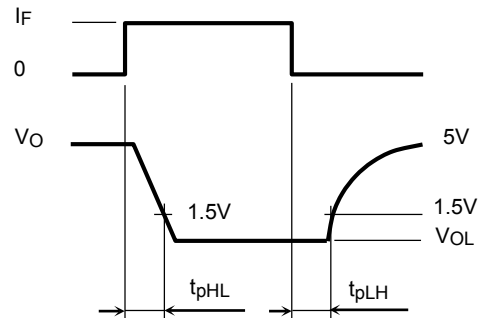
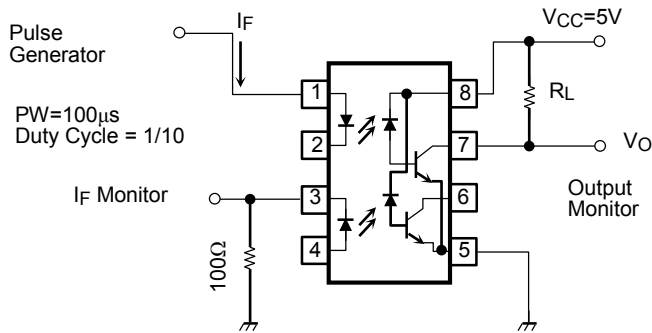

Test Circuit 2: Common mode transient Immunity and Typical Waveform

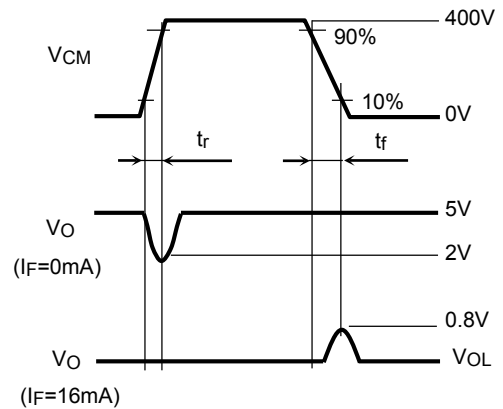
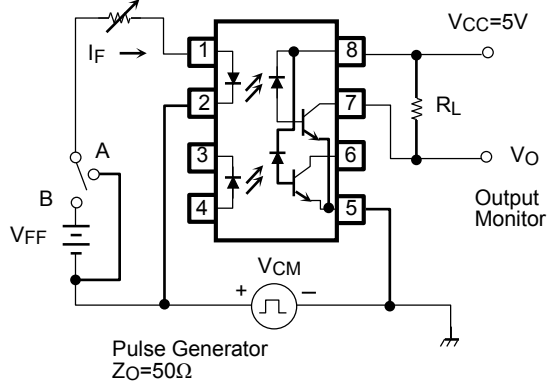

$$CM_H = \frac{320(V)}{t_r(\mu s)}, CM_L = \frac{320(V)}{t_f(\mu s)}$$

Test Circuit 3: Frequency Response

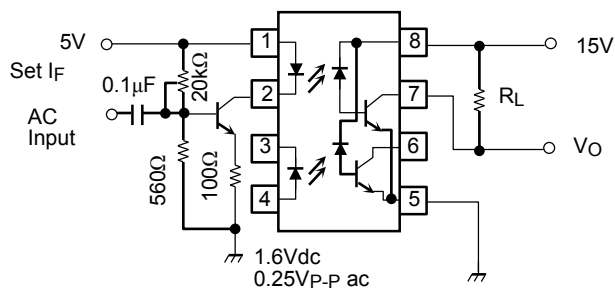

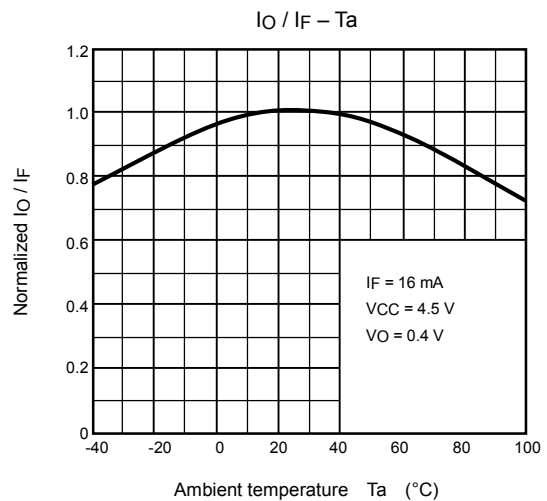
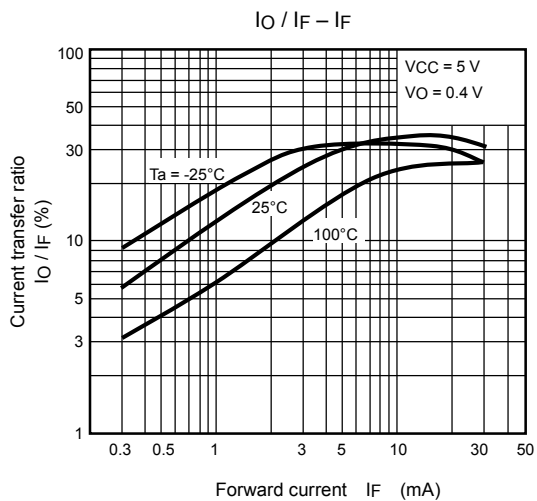
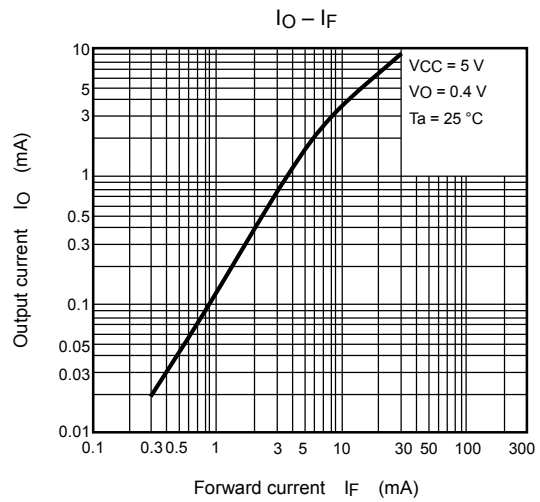
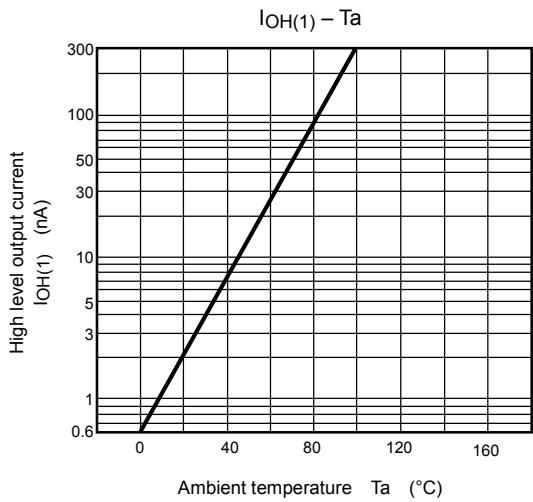
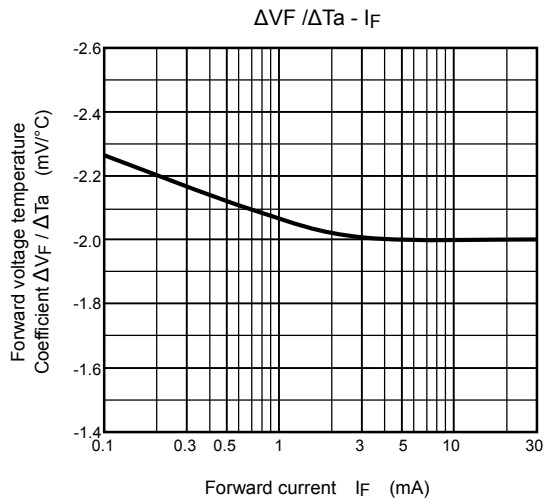
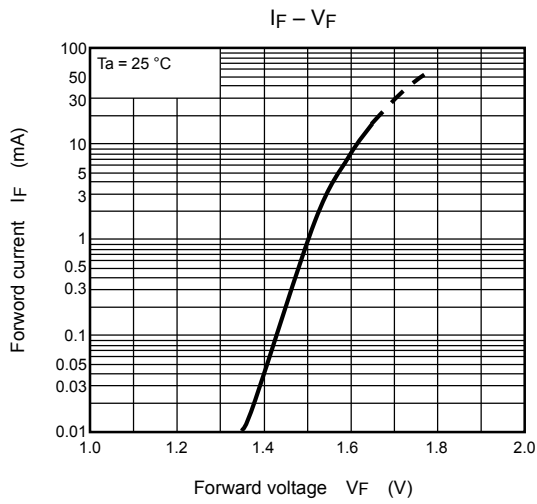

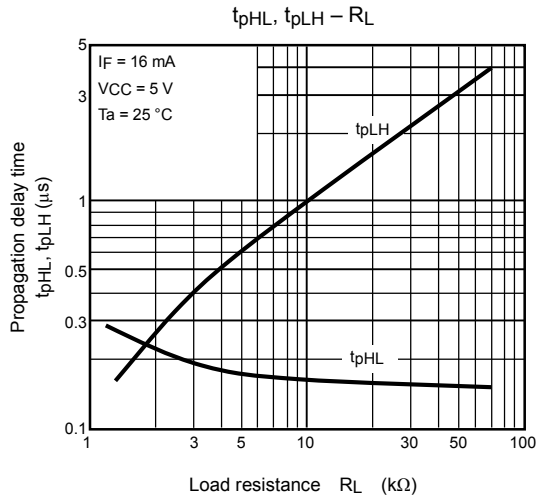
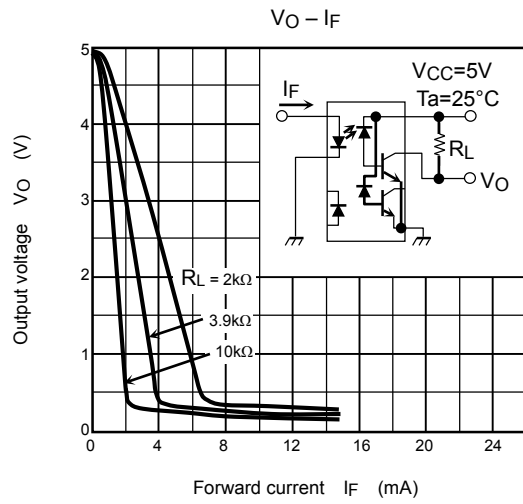
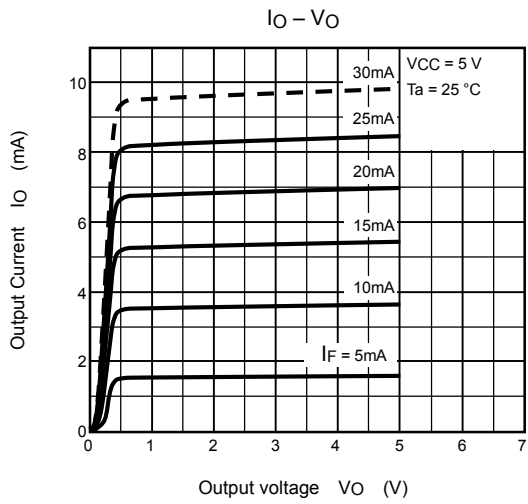

RESTRICTIONS ON PRODUCT USE

- Toshiba Corporation, and its subsidiaries and affiliates (collectively "TOSHIBA"), reserve the right to make changes to the information in this document, and related hardware, software and systems (collectively "Product") without notice.
- This document and any information herein may not be reproduced without prior written permission from TOSHIBA. Even with TOSHIBA's written permission, reproduction is permissible only if reproduction is without alteration/omission.
- Though TOSHIBA works continually to improve Product's quality and reliability, Product can malfunction or fail. Customers are responsible for complying with safety standards and for providing adequate designs and safeguards for their hardware, software and systems which minimize risk and avoid situations in which a malfunction or failure of Product could cause loss of human life, bodily injury or damage to property, including data loss or corruption. Before customers use the Product, create designs including the Product, or incorporate the Product into their own applications, customers must also refer to and comply with (a) the latest versions of all relevant TOSHIBA information, including without limitation, this document, the specifications, the data sheets and application notes for Product and the precautions and conditions set forth in the "TOSHIBA Semiconductor Reliability Handbook" and (b) the instructions for the application with which the Product will be used with or for. Customers are solely responsible for all aspects of their own product design or applications, including but not limited to (a) determining the appropriateness of the use of this Product in such design or applications; (b) evaluating and determining the applicability of any information contained in this document, or in charts, diagrams, programs, algorithms, sample application circuits, or any other referenced documents; and (c) validating all operating parameters for such designs and applications. **TOSHIBA ASSUMES NO LIABILITY FOR CUSTOMERS' PRODUCT DESIGN OR APPLICATIONS.**
- **PRODUCT IS NEITHER INTENDED NOR WARRANTED FOR USE IN EQUIPMENTS OR SYSTEMS THAT REQUIRE EXTRAORDINARILY HIGH LEVELS OF QUALITY AND/OR RELIABILITY, AND/OR A MALFUNCTION OR FAILURE OF WHICH MAY CAUSE LOSS OF HUMAN LIFE, BODILY INJURY, SERIOUS PROPERTY DAMAGE AND/OR SERIOUS PUBLIC IMPACT ("UNINTENDED USE").** Except for specific applications as expressly stated in this document, Unintended Use includes, without limitation, equipment used in nuclear facilities, equipment used in the aerospace industry, medical equipment, equipment used for automobiles, trains, ships and other transportation, traffic signaling equipment, equipment used to control combustions or explosions, safety devices, elevators and escalators, devices related to electric power, and equipment used in finance-related fields. **IF YOU USE PRODUCT FOR UNINTENDED USE, TOSHIBA ASSUMES NO LIABILITY FOR PRODUCT.** For details, please contact your TOSHIBA sales representative.
- Do not disassemble, analyze, reverse-engineer, alter, modify, translate or copy Product, whether in whole or in part.
- Product shall not be used for or incorporated into any products or systems whose manufacture, use, or sale is prohibited under any applicable laws or regulations.
- The information contained herein is presented only as guidance for Product use. No responsibility is assumed by TOSHIBA for any infringement of patents or any other intellectual property rights of third parties that may result from the use of Product. No license to any intellectual property right is granted by this document, whether express or implied, by estoppel or otherwise.
- **ABSENT A WRITTEN SIGNED AGREEMENT, EXCEPT AS PROVIDED IN THE RELEVANT TERMS AND CONDITIONS OF SALE FOR PRODUCT, AND TO THE MAXIMUM EXTENT ALLOWABLE BY LAW, TOSHIBA (1) ASSUMES NO LIABILITY WHATSOEVER, INCLUDING WITHOUT LIMITATION, INDIRECT, CONSEQUENTIAL, SPECIAL, OR INCIDENTAL DAMAGES OR LOSS, INCLUDING WITHOUT LIMITATION, LOSS OF PROFITS, LOSS OF OPPORTUNITIES, BUSINESS INTERRUPTION AND LOSS OF DATA, AND (2) DISCLAIMS ANY AND ALL EXPRESS OR IMPLIED WARRANTIES AND CONDITIONS RELATED TO SALE, USE OF PRODUCT, OR INFORMATION, INCLUDING WARRANTIES OR CONDITIONS OF MERCHANTABILITY, FITNESS FOR A PARTICULAR PURPOSE, ACCURACY OF INFORMATION, OR NONINFRINGEMENT.**
- GaAs (Gallium Arsenide) is used in Product. GaAs is harmful to humans if consumed or absorbed, whether in the form of dust or vapor. Handle with care and do not break, cut, crush, grind, dissolve chemically or otherwise expose GaAs in Product.
- Do not use or otherwise make available Product or related software or technology for any military purposes, including without limitation, for the design, development, use, stockpiling or manufacturing of nuclear, chemical, or biological weapons or missile technology products (mass destruction weapons). Product and related software and technology may be controlled under the applicable export laws and regulations including, without limitation, the Japanese Foreign Exchange and Foreign Trade Law and the U.S. Export Administration Regulations. Export and re-export of Product or related software or technology are strictly prohibited except in compliance with all applicable export laws and regulations.
- Please contact your TOSHIBA sales representative for details as to environmental matters such as the RoHS compatibility of Product. Please use Product in compliance with all applicable laws and regulations that regulate the inclusion or use of controlled substances, including without limitation, the EU RoHS Directive. **TOSHIBA ASSUMES NO LIABILITY FOR DAMAGES OR LOSSES OCCURRING AS A RESULT OF NONCOMPLIANCE WITH APPLICABLE LAWS AND REGULATIONS.**

Looking for pricing, stock, or lifecycle information?

Click below to explore more details on WIN SOURCE:

- [View TLP2530\(F\) on WIN SOURCE](#)
- [Toshiba Semiconductor and Storage Information](#)

Optimize Your Supply Chain with WIN SOURCE Solutions

- ✓ Global Sourcing Solution
- ✓ Obsolete Management
- ✓ Cost Control Management
- ✓ Shortage Management
- ✓ Alternative Solution
- ✓ Excess Inventory Management