

LM3481 / -Q1 High-Efficiency Controller for Boost, SEPIC and Flyback DC-DC Converters

1 Features

- LM3481QMM are Automotive-Grade Products That are AEC-Q100 Grade 1 Qualified (–40°C to +125°C Operating Junction Temperature)
- 10-Lead VSSOP Package
- Internal Push-Pull Driver With 1-A Peak Current Capability
- Current Limit and Thermal Shutdown
- Frequency Compensation Optimized With a Capacitor and a Resistor
- Internal Softstart
- Current Mode Operation
- Adjustable Undervoltage Lockout With Hysteresis
- Pulse Skipping at Light Loads
- Key Specifications
 - Wide Supply Voltage Range of 2.97 V to 48 V
 - 100-kHz to 1-MHz Adjustable and Synchronizable Clock Frequency
 - $\pm 1.5\%$ (Over Temperature) Internal Reference
 - 10- μ A Shutdown Current (Over Temperature)
- Create a Custom Design Using the LM3481 with the [WEBENCH Power Designer](#)

2 Applications

- Automotive Start-Stop Applications
- Automotive ADAS Driver Information
- One Cell/Two Cell Li-ion Battery Powered Portable Bluetooth Audio Systems
- Notebooks, PDAs, Digital Cameras, and Other Portable Applications
- Offline Power Supplies
- Set-Top Boxes
- Boost for Audio Amplifiers

3 Description

The LM3481 device is a versatile Low-Side N-FET high-performance controller for switching regulators. The device is designed for use in Boost, SEPIC and Flyback converters and topologies requiring a low-side FET as the primary switch. The LM3481 device can be operated at very high switching frequencies to reduce the overall solution size. The switching frequency of the LM3481 device can be adjusted to any value between 100kHz and 1MHz by using a single external resistor or by synchronizing it to an external clock. Current mode control provides superior bandwidth and transient response in addition to cycle-by-cycle current limiting. Current limit can be programmed with a single external resistor.

The LM3481 device has built-in protection features such as thermal shutdown, short-circuit protection and overvoltage protection. Power-saving shutdown mode reduces the total supply current to 5 μ A and allows power supply sequencing. Internal soft-start limits the inrush current at start-up. Integrated current slope compensation simplifies the design and, if needed for specific applications, can be increased using a single resistor.

Device Information⁽¹⁾

PART NUMBER	PACKAGE	BODY SIZE (NOM)
LM3481	VSSOP (10)	3.00 mm x 3.00 mm
LM3481-Q1		

(1) For all available packages, see the orderable addendum at the end of the data sheet.

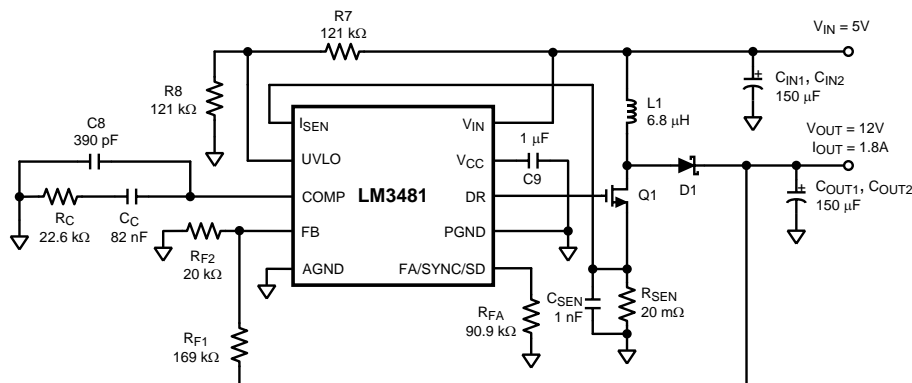

Figure 1. LM3481 Typical 5V to 12V Boost Converter Application



Table of Contents

1 Features	1	7.3 Feature Description.....	12
2 Applications	1	7.4 Device Functional Modes.....	18
3 Description	1	8 Application and Implementation	19
4 Revision History	2	8.1 Application Information.....	19
5 Pin Configuration and Functions	3	8.2 Typical Applications	19
6 Specifications	4	9 Power Supply Recommendations	30
6.1 Absolute Maximum Ratings	4	10 Layout	30
6.2 Handling Ratings: LM3481.....	4	10.1 Layout Guidelines	30
6.3 Handling Ratings: LM3481-Q1.....	4	10.2 Layout Example	31
6.4 Recommended Operating Ratings.....	4	11 Device and Documentation Support	32
6.5 Thermal Information	5	11.1 Documentation Support	32
6.6 Electrical Characteristics.....	5	11.2 Related Links	32
6.7 Typical Characteristics.....	8	11.3 Trademarks	32
7 Detailed Description	11	11.4 Electrostatic Discharge Caution.....	32
7.1 Overview	11	11.5 Glossary	32
7.2 Functional Block Diagram	12	12 Mechanical, Packaging, and Orderable Information	33

4 Revision History

Changes from Revision E (April 2012) to Revision F

Page

- Added *Pin Configuration and Functions* section, *Handling Rating* table, *Feature Description* section, *Device Functional Modes*, *Application and Implementation* section, *Power Supply Recommendations* section, *Layout* section, *Device and Documentation Support* section, and *Mechanical, Packaging, and Orderable Information* section

1

5 Pin Configuration and Functions

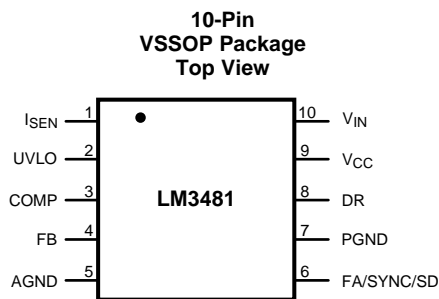

Pin Functions

PIN		I/O	DESCRIPTION
NO.	NAME		
1	I _{SEN}	A	Current sense input pin. Voltage generated across an external sense resistor is fed into this pin.
2	UVLO	A	Under voltage lockout pin. A resistor divider from V _{IN} to ground is connected to the UVLO pin. The ratio of these resistances determine the input voltage which allows switching and the hysteresis to disable switching.
3	COMP	A	Compensation pin. A resistor and capacitor combination connected to this pin provides compensation for the control loop.
4	FB	A	Feedback pin. Inverting input of the error amplifier.
5	AGND	G	Analog ground pin. Internal bias circuitry reference. Should be connected to PGND at a single point.
6	FA/SYNC/SD	I/A	Frequency adjust, synchronization, and shutdown pin. A resistor connected from this pin to ground sets the oscillator frequency. An external clock signal at this pin will synchronize the controller to the frequency of the clock. A high level on this pin for $\geq 30 \mu\text{s}$ will turn the device off and the device will then draw $5 \mu\text{A}$ from the supply typically.
7	PGND	G	Power ground pin. External power circuitry reference. Should be connected to AGND at a single point.
8	DR	O	Drive pin of the IC. The gate of the external MOSFET should be connected to this pin.
9	V _{CC}	O	Driver supply voltage pin. A bypass capacitor must be connected from this pin to PGND. See Driver Supply Capacitor Selection section. Do not bias externally.
10	V _{IN}	P	Power supply input pin.

6 Specifications

6.1 Absolute Maximum Ratings

 over operating free-air temperature range (unless otherwise noted)⁽¹⁾

		MIN	MAX	UNIT
V _{IN}	Pin Voltage	-0.4	50	V
FB	Pin Voltage	-0.4	6	V
FA/SYNC/SD	Pin Voltage	-0.4	6	V
COMP	Pin Voltage	-0.4	6	V
UVLO	Pin Voltage	-0.4	6	V
V _{CC}	Pin Voltage	-0.4	6.5	V
DR	Pin Voltage	-0.4	6	V
I _{SEN}	Pin Voltage	-400	600	mV
Peak Driver Output Current		1		A
Power Dissipation		Internally Limited		
Junction Temperature		150		°C
Lead Temperature (only applies to operating conditions)	DGS Package	220		°C
Peak Body Temperature ⁽²⁾		260		°C

- (1) Absolute Maximum Ratings are limits beyond which damage to the device may occur. [Recommended Operating Ratings](#) indicates conditions for which the device is intended to be functional, but does not ensure specific performance limits. For ensured specifications and test conditions, see the [Electrical Characteristics](#). The ensured specifications apply only for the test conditions.
- (2) Part is MSL1-260C qualified

6.2 Handling Ratings: LM3481

		MIN	MAX	UNIT	
T _{stg}	Storage temperature range	-65	150	°C	
V _(ESD)	Electrostatic discharge	Human body model (HBM), per ANSI/ESDA/JEDEC JS-001, all pins ⁽¹⁾	-2000	+2000	V
		Charged device model (CDM), per JEDEC specification JESD22-C101, all pins ⁽²⁾	-750	+750	

- (1) JEDEC document JEP155 states that 500-V HBM allows safe manufacturing with a standard ESD control process.
- (2) JEDEC document JEP157 states that 250-V CDM allows safe manufacturing with a standard ESD control process.

6.3 Handling Ratings: LM3481-Q1

		MIN	MAX	UNIT		
T _{stg}	Storage temperature range	-65	150	°C		
V _(ESD)	Electrostatic discharge	Human body model (HBM), per AEC Q100-002 ⁽¹⁾	-2000	+2000	V	
		Charged device model (CDM), per AEC Q100-011	Corner pins (1, 5, 6, and 10)	-750		+750
			Other pins	-750		+750

- (1) AEC Q100-002 indicates HBM stressing is done in accordance with the ANSI/ESDA/JEDEC JS-001 specification.

6.4 Recommended Operating Ratings

	MIN	MAX	UNIT
Supply Voltage	2.97	48	V
Junction Temperature Range	-40	125	°C
Switching Frequency Range	100	1	kHz/MHz

6.5 Thermal Information

THERMAL METRIC ⁽¹⁾		LM3481	UNIT
		VSSOP	
		10 PINS	
R _{θJA}	Junction-to-ambient thermal resistance	157.3	°C/W
R _{θJC(top)}	Junction-to-case (top) thermal resistance	51.1	
R _{θJB}	Junction-to-board thermal resistance	76.9	
ψ _{JT}	Junction-to-top characterization parameter	5.0	
ψ _{JB}	Junction-to-board characterization parameter	75.6	
R _{θJC(bot)}	Junction-to-case (bottom) thermal resistance	-	

(1) For more information about traditional and new thermal metrics, see the *IC Package Thermal Metrics* application report, [SPRA953](#).

6.6 Electrical Characteristics

V_{IN} = 12 V, R_{FA} = 40 kΩ, T_J = 25°C, unless otherwise indicated.

PARAMETER	TEST CONDITIONS	MIN	TYP	MAX	UNIT	
V _{FB}	Feedback Voltage	V _{COMP} = 1.4 V, 2.97 ≤ V _{IN} ≤ 48 V		1.275	V	
		V _{COMP} = 1.4 V, 2.97 ≤ V _{IN} ≤ 48 V, -40°C ≤ T _J ≤ 125°C	1.256	1.294		
ΔV _{LINE}	Feedback Voltage Line Regulation	2.97 ≤ V _{IN} ≤ 48 V		0.003	%/V	
ΔV _{LOAD}	Output Voltage Load Regulation	I _{EAO} Source/Sink		±0.5	%/A	
V _{UVLOSEN}	Undervoltage Lockout Reference Voltage	V _{UVLO} Ramping Down		1.430	V	
		V _{UVLO} Ramping Down, -40°C ≤ T _J ≤ 125°C	1.345	1.517		
I _{UVLO}	UVLO Source Current	Enabled		5	μA	
		Enabled, -40°C ≤ T _J ≤ 125°C	3	6		
V _{UVLOSD}	UVLO Shutdown Voltage	0.55	0.7	0.82	V	
I _{COMP}	COMP pin Current Sink	V _{FB} = 0V		640	μA	
V _{COMP}		V _{FB} = 1.275V		1	V	
f _{nom}	Nominal Switching Frequency	R _{FA} = 40 kΩ		475	kHz	
		R _{FA} = 40 kΩ, -40°C ≤ T _J ≤ 125°C	406	550		
V _{sync-HI}	Threshold for Synchronization on FA/SYNC/SD pin	Synchronization Voltage Rising		1.4	V	
V _{sync-LOW}	Threshold for Synchronization on FA/SYNC/SD pin	Synchronization Voltage Falling		0.7	V	
R _{DS1 (ON)}	Driver Switch On Resistance (top)	I _{DR} = 0.2A, V _{IN} = 5 V		4	Ω	
R _{DS2 (ON)}	Driver Switch On Resistance (bottom)	I _{DR} = 0.2A		2	Ω	
V _{DR (max)}	Maximum Drive Voltage Swing ⁽¹⁾	V _{IN} < 6V		V _{IN}	V	
		V _{IN} ≥ 6V		6		
D _{max}	Maximum Duty Cycle	81%	85%			
t _{min (on)}	Minimum On Time			250	363	ns
		worst case over temperature			571	ns
I _{SUPPLY}	Supply Current (switching)	See ⁽²⁾		3.7	mA	
		See ⁽²⁾ , -40°C ≤ T _J ≤ 125°C				5.0

(1) The drive pin voltage, V_{DR}, is equal to the input voltage when input voltage is less than 6 V. V_{DR} is equal to 6 V when the input voltage is greater than or equal to 6 V.

(2) For this test, the FA/SYNC/SD Pin is pulled to ground using a 40-kΩ resistor.

Electrical Characteristics (continued)
 $V_{IN} = 12\text{ V}$, $R_{FA} = 40\text{ k}\Omega$, $T_J = 25^\circ\text{C}$, unless otherwise indicated.

PARAMETER	TEST CONDITIONS	MIN	TYP	MAX	UNIT	
I_Q	Quiescent Current in Shutdown Mode		9	15	μA	
						$V_{FA}/\text{SYNC}/\text{SD} = 3\text{ V}^{(3)}$, $V_{IN} = 12\text{ V}$, $-40^\circ\text{C} \leq T_J \leq 125^\circ\text{C}$
						$V_{FA}/\text{SYNC}/\text{SD} = 3\text{ V}^{(3)}$, $V_{IN} = 5\text{ V}$
						$V_{FA}/\text{SYNC}/\text{SD} = 3\text{ V}^{(3)}$, $V_{IN} = 5\text{ V}$, $-40^\circ\text{C} \leq T_J \leq 125^\circ\text{C}$
V_{SENSE}	Current Sense Threshold Voltage		160	190	mV	
						$-40^\circ\text{C} \leq T_J \leq 125^\circ\text{C}$
V_{SC}	Over Load Current Limit Sense Voltage		220	275	mV	
						$-40^\circ\text{C} \leq T_J \leq 125^\circ\text{C}$
V_{SL}	Internal Compensation Ramp Voltage		90		mV	
V_{OVP}	Output Over-voltage Protection (with respect to feedback voltage) ⁽⁴⁾		85	135	mV	
						$V_{\text{COMP}} = 1.4\text{ V}$, $-40^\circ\text{C} \leq T_J \leq 125^\circ\text{C}$
$V_{\text{OVP(HYS)}}$	Output Over-Voltage Protection Hysteresis		70	106	mV	
						$V_{\text{COMP}} = 1.4\text{ V}$, $-40^\circ\text{C} \leq T_J \leq 125^\circ\text{C}$
G_m	Error Amplifier Transconductance		450	690	μmho	
						$V_{\text{COMP}} = 1.4\text{ V}$, $-40^\circ\text{C} \leq T_J \leq 125^\circ\text{C}$
A_{VOL}	Error Amplifier Voltage Gain		60	66	V/V	
						$V_{\text{COMP}} = 1.4\text{ V}$, $I_{\text{EAO}} = 100\text{ }\mu\text{A}$ (Source/Sink), $-40^\circ\text{C} \leq T_J \leq 125^\circ\text{C}$
I_{EAO}	Error Amplifier Output Current (Source/Sink)		640	837	μA	
						Source, $V_{\text{COMP}} = 1.4\text{ V}$, $V_{\text{FB}} = 1.1\text{ V}$
						Source, $V_{\text{COMP}} = 1.4\text{ V}$, $V_{\text{FB}} = 1.1\text{ V}$, $-40^\circ\text{C} \leq T_J \leq 125^\circ\text{C}$
						Sink, $V_{\text{COMP}} = 1.4\text{ V}$, $V_{\text{FB}} = 1.4\text{ V}$
V_{EAO}	Error Amplifier Output Voltage Swing		2.70	2.93	V	
						Upper Limit: $V_{\text{FB}} = 0\text{ V}$, COMP Pin Floating
						Upper Limit: $V_{\text{FB}} = 0\text{ V}$, COMP Pin Floating, $-40^\circ\text{C} \leq T_J \leq 125^\circ\text{C}$
						Lower Limit: $V_{\text{FB}} = 1.4\text{ V}$
t_{SS}	Internal Soft-Start Delay		8.7	21.3	ms	
						$V_{\text{FB}} = 1.2\text{ V}$, COMP Pin Floating
t_r	Drive Pin Rise Time		25		ns	
t_f	Drive Pin Fall Time		25		ns	
V_{SD}	Shutdown signal threshold ⁽⁵⁾ FA/SYNC/SD pin		1.31	1.40	V	
						Output = High (Shutdown)
						Output = High (Shutdown), $-40^\circ\text{C} \leq T_J \leq 125^\circ\text{C}$
						Output = Low (Enable)
V_{SD}	Shutdown signal threshold ⁽⁵⁾ FA/SYNC/SD pin		0.68	0.40	V	
						Output = Low (Enable), $-40^\circ\text{C} \leq T_J \leq 125^\circ\text{C}$

(3) For this test, the FA/SYNC/SD Pin is pulled to 3 V using a 40-k Ω resistor.

(4) The overvoltage protection is specified with respect to the feedback voltage. This is because the overvoltage protection tracks the feedback voltage. The overvoltage threshold can be calculated by adding the feedback voltage (V_{FB}) to the overvoltage protection specification.

(5) The FA/SYNC/SD pin should be pulled to V_{IN} through a resistor to turn the regulator off. The voltage on the FA/SYNC/SD pin must be above the max limit for the Output = High longer than 30 μs to keep the regulator off and must be below the minimum limit for Output = Low to keep the regulator on.

Electrical Characteristics (continued)
 $V_{IN} = 12\text{ V}$, $R_{FA} = 40\text{ k}\Omega$, $T_J = 25^\circ\text{C}$, unless otherwise indicated.

PARAMETER		TEST CONDITIONS	MIN	TYP	MAX	UNIT
I_{SD}	Shutdown Pin Current FA/SYNC/SD pin	$V_{SD} = 5\text{ V}$		-1		μA
		$V_{SD} = 0\text{ V}$		20		
T_{SD}	Thermal Shutdown			165		$^\circ\text{C}$
T_{sh}	Thermal Shutdown Hysteresis			10		$^\circ\text{C}$

6.7 Typical Characteristics

Unless otherwise specified, $V_{IN} = 12\text{ V}$, $T_J = 25^\circ\text{C}$.

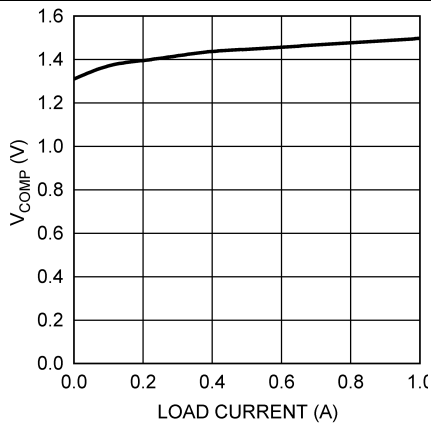

Figure 3. Comp Pin Voltage vs. Load Current

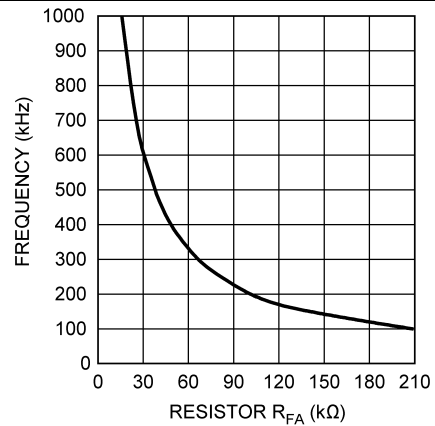

Figure 4. Switching Frequency vs. R_{FA}

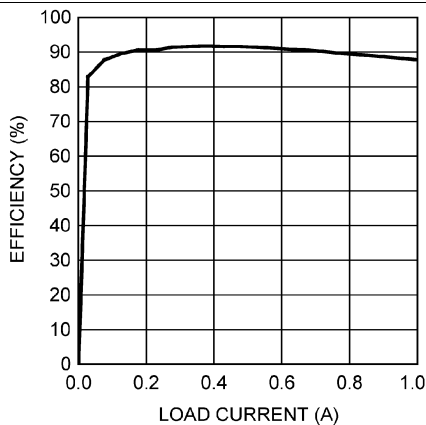

Figure 5. Efficiency vs. Load Current (3.3 V_{IN} and 12 V_{OUT})

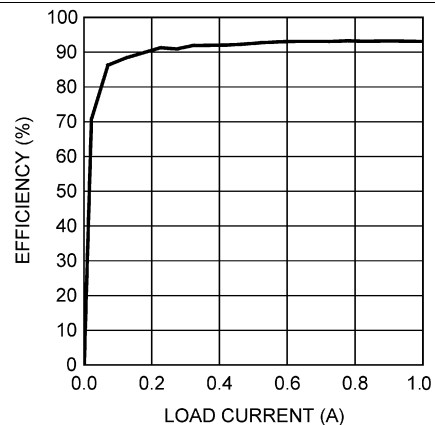

Figure 6. Efficiency vs. Load Current (5 V_{IN} and 12 V_{OUT})

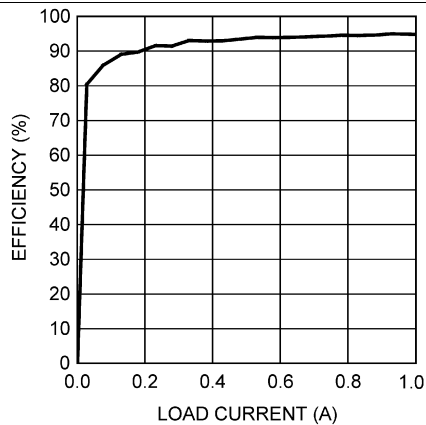

Figure 7. Efficiency vs. Load Current (9 V_{IN} and 12 V_{OUT})

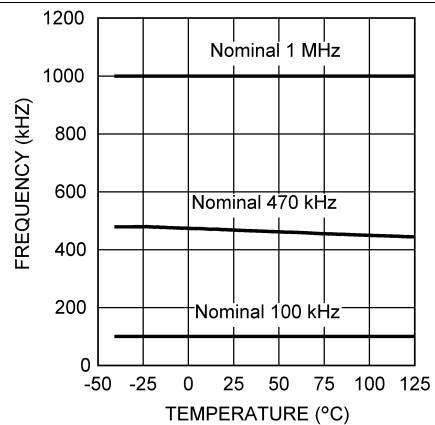

Figure 8. Frequency vs. Temperature

Typical Characteristics (continued)

Unless otherwise specified, $V_{IN} = 12\text{ V}$, $T_J = 25^\circ\text{C}$.

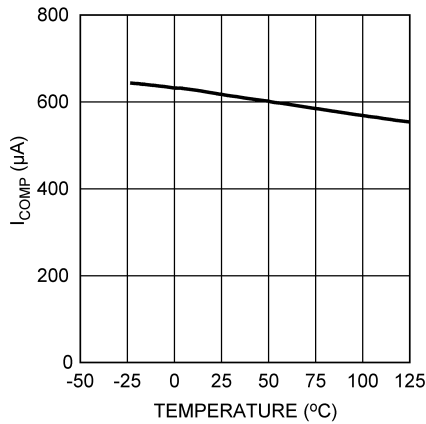

Figure 9. COMP Pin Source Current vs. Temperature

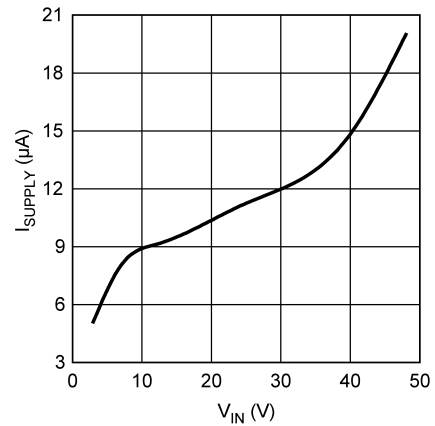

Figure 10. I_{Supply} vs. Input Voltage (Nonswitching)

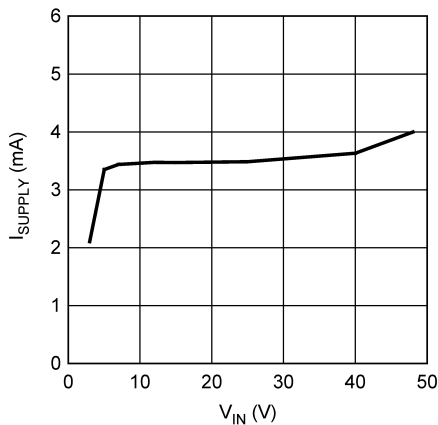

Figure 11. I_{Supply} vs. Input Voltage (Switching)

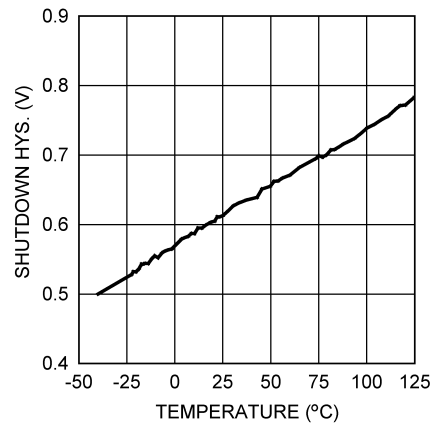

Figure 12. Shutdown Threshold Hysteresis vs. Temperature

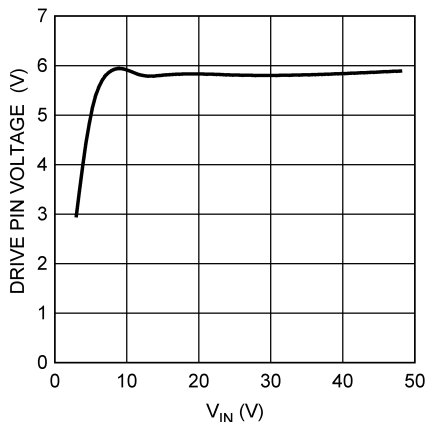

Figure 13. Drive Voltage vs. Input Voltage

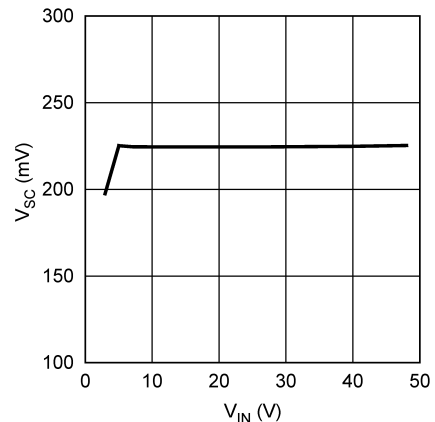

Figure 14. Short Circuit Protection vs. V_{IN}

Typical Characteristics (continued)

Unless otherwise specified, $V_{IN} = 12\text{ V}$, $T_J = 25^\circ\text{C}$.

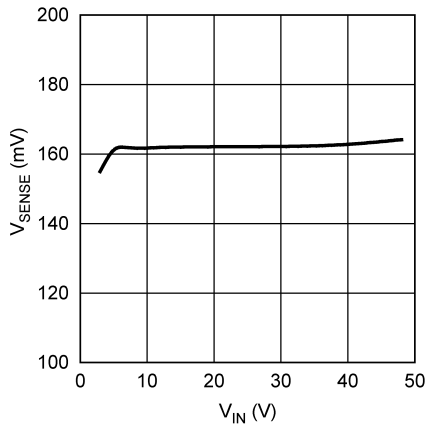

Figure 15. Current Sense Threshold vs. Input Voltage

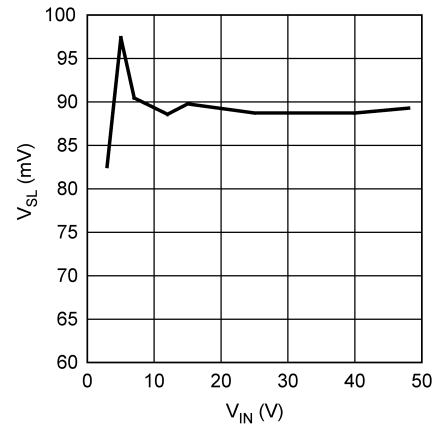

Figure 16. Compensation Ramp Amplitude vs. Input Voltage

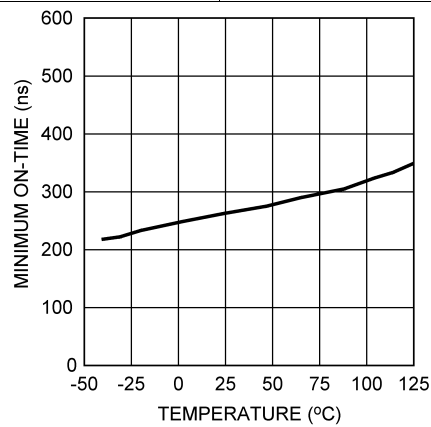

Figure 17. Minimum On-Time vs. Temperature

7 Detailed Description

7.1 Overview

The LM3481 device uses a fixed frequency, Pulse Width Modulated (PWM), current mode control architecture. In a typical application circuit, the peak current through the external MOSFET is sensed through an external sense resistor. The voltage across this resistor is fed into the I_{SEN} pin. This voltage is then level shifted and fed into the positive input of the PWM comparator. The output voltage is also sensed through an external feedback resistor divider network and fed into the error amplifier (EA) negative input (feedback pin, FB). The output of the error amplifier (COMP pin) is added to the slope compensation ramp and fed into the negative input of the PWM comparator.

At the start of any switching cycle, the oscillator sets the RS latch using the SET/Blank-out and switch logic blocks. This forces a high signal on the DR pin (gate of the external MOSFET) and the external MOSFET turns on. When the voltage on the positive input of the PWM comparator exceeds the negative input, the RS latch is reset and the external MOSFET turns off.

The voltage sensed across the sense resistor generally contains spurious noise spikes, as shown in Figure 18. These spikes can force the PWM comparator to reset the RS latch prematurely. To prevent these spikes from resetting the latch, a blank-out circuit inside the IC prevents the PWM comparator from resetting the latch for a short duration after the latch is set. This duration, called the blank-out time, is typically 250 ns and is specified as t_{min} (on) in the *Electrical Characteristics* section.

Under extremely light load or no-load conditions, the energy delivered to the output capacitor when the external MOSFET is on during the blank-out time is more than what is delivered to the load. An overvoltage comparator inside the LM3481 prevents the output voltage from rising under these conditions by sensing the feedback (FB pin) voltage and resetting the RS latch. The latch remains in a reset state until the output decays to the nominal value. Thus the operating frequency decreases at light loads, resulting in excellent efficiency.

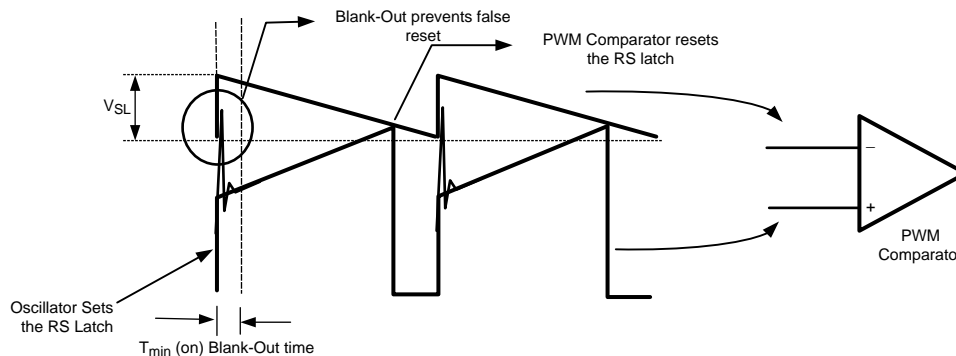

Figure 18. Basic Operation of the PWM Comparator

7.2 Functional Block Diagram

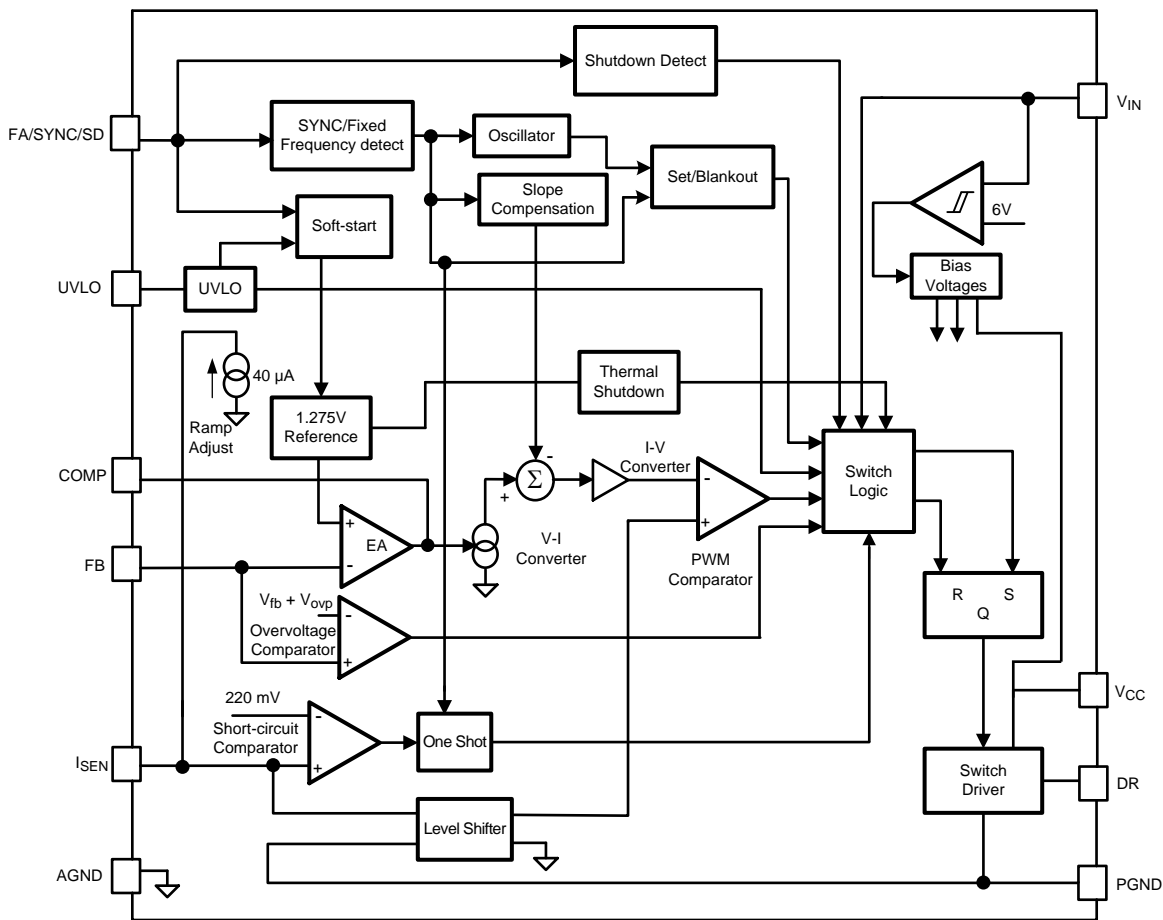

Figure 19. LM3481 Simplified Functional Block Diagram

7.3 Feature Description

7.3.1 Overvoltage Protection

The LM3481 has overvoltage protection (OVP) for the output voltage. OVP is sensed at the feedback pin (FB). If at anytime the voltage at the feedback pin rises to $V_{FB} + V_{OVP}$, OVP is triggered. See the [Electrical Characteristics](#) section for limits on V_{FB} and V_{OVP} .

OVP will cause the drive pin (DR) to go low, forcing the power MOSFET off. With the MOSFET off, the output voltage will drop. The LM3481 will begin switching again when the feedback voltage reaches $V_{FB} + (V_{OVP} - V_{OVP(HYS)})$. See the [Electrical Characteristics](#) section for limits on $V_{OVP(HYS)}$. The Error Amplifier is operational during OVP events.

7.3.2 Bias Voltage

The internal bias of the LM3481 comes from either the internal bias voltage generator as shown in the block diagram or directly from the voltage at the VIN pin. At input voltages lower than 6 V the internal IC bias is the input voltage and at voltages above 6 V the internal bias voltage generator of the LM3481 provides the bias. The voltage for the gate driver is output on the VCC pin for compensation by an external capacitor (0.47μF to 4.7μF depending on the FET requirements). Biasing the VCC pin by an external voltage source should not be attempted.

Feature Description (continued)

7.3.3 Slope Compensation Ramp

The LM3481 uses a current mode control scheme. The main advantages of current mode control are inherent cycle-by-cycle current limit for the switch and simpler control loop characteristics. It is easy to parallel power stages using current mode control because current sharing is automatic. However there is a natural instability that will occur for duty cycles, D, greater than 50% if additional slope compensation is not addressed as described below.

The current mode control scheme samples the inductor current, I_L , and compares the sampled signal, $V_{s\text{amp}}$, to an internally generated control signal, V_C . The current sense resistor, R_{SEN} , as shown in Figure 23, converts the sampled inductor current, I_L , to the voltage signal, $V_{s\text{amp}}$, that is proportional to I_L such that:

$$V_{s\text{amp}} = I_L \times R_{\text{SEN}} \tag{1}$$

The rising and falling slopes, M_1 and $-M_2$ respectively, of $V_{s\text{amp}}$ are also proportional to the inductor current rising and falling slopes, M_{on} and $-M_{\text{off}}$ respectively. Where M_{on} is the inductor slope during the switch on-time and $-M_{\text{off}}$ is the inductor slope during the switch off-time and are related to M_1 and $-M_2$ by:

$$M_1 = M_{\text{on}} \times R_{\text{SEN}} \tag{2}$$

$$-M_2 = -M_{\text{off}} \times R_{\text{SEN}} \tag{3}$$

For the boost topology:

$$M_{\text{on}} = V_{\text{IN}} / L \tag{4}$$

$$-M_{\text{off}} = (V_{\text{IN}} - V_{\text{OUT}}) / L \tag{5}$$

$$M_1 = [V_{\text{IN}} / L] \times R_{\text{SEN}} \tag{6}$$

$$-M_2 = [(V_{\text{IN}} - V_{\text{OUT}}) / L] \times R_{\text{SEN}} \tag{7}$$

$$M_2 = [(V_{\text{OUT}} - V_{\text{IN}}) / L] \times R_{\text{SEN}} \tag{8}$$

Current mode control has an inherent instability for duty cycles greater than 50%, as shown in Figure 20, where the control signal slope, M_C , equals zero. In Figure 20, a small increase in the load current causes the sampled signal to increase by $\Delta V_{s\text{amp}0}$. The effect of this load change, $\Delta V_{s\text{amp}1}$, at the end of the first switching cycle is :

$$\Delta V_{s\text{amp}1} = -\left(\frac{M_2}{M_1}\right) \Delta V_{s\text{amp}0} = -\left(\frac{D}{1-D}\right) \Delta V_{s\text{amp}0} \tag{9}$$

From Equation 9, when $D > 0.5$, $\Delta V_{s\text{amp}1}$ will be greater than $\Delta V_{s\text{amp}0}$. In other words, the disturbance is divergent. So a very small perturbation in the load will cause the disturbance to increase. To ensure that the perturbed signal converges we must maintain:

$$\left| \frac{M_2}{M_1} \right| < 1 \tag{10}$$

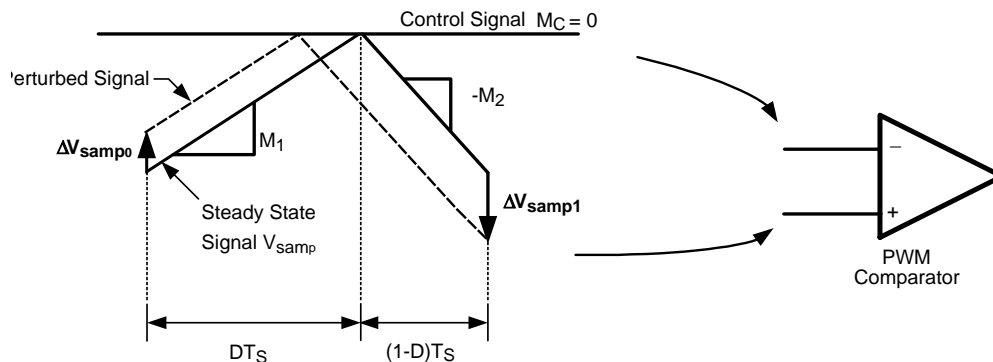

Figure 20. Subharmonic Oscillation for $D > 0.5$

Feature Description (continued)

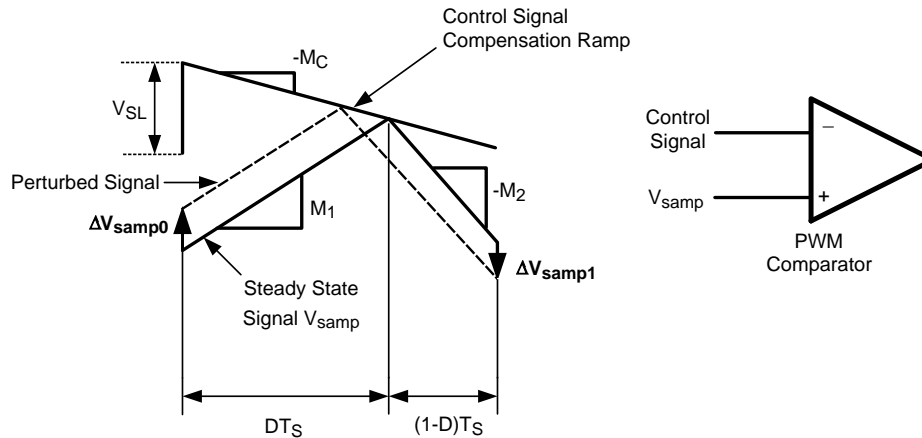

Figure 21. Compensation Ramp Avoids Subharmonic Oscillation

To prevent the subharmonic oscillations, a compensation ramp is added to the control signal, as shown in [Figure 21](#).

With the compensation ramp, $\Delta V_{s\text{amp}1}$ and the convergence criteria are expressed by,

$$\Delta V_{s\text{amp}1} = -\left(\frac{M_2 - M_C}{M_1 + M_C}\right) \Delta V_{s\text{amp}0} \tag{11}$$

$$\left| \frac{M_2 - M_C}{M_1 + M_C} \right| < 1 \tag{12}$$

The compensation ramp has been added internally in the LM3481. The slope of this compensation ramp has been selected to satisfy most applications, and its value depends on the switching frequency. This slope can be calculated using the formula:

$$M_C = V_{SL} \times f_S \tag{13}$$

In [Equation 13](#), V_{SL} is the amplitude of the internal compensation ramp and f_S is the controller's switching frequency. Limits for V_{SL} have been specified in the [Electrical Characteristics](#) section.

To provide the user additional flexibility, a patented scheme has been implemented inside the IC to increase the slope of the compensation ramp externally, if the need arises. Adding a single external resistor, R_{SL} (as shown in [Figure 23](#)) increases the amplitude of the compensation ramp as shown in [Figure 22](#).

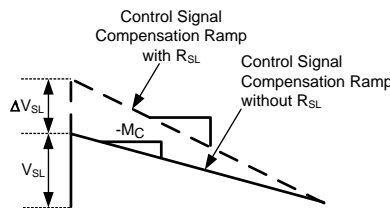

Figure 22. Additional Slope Compensation Added Using External Resistor R_{SL}

Where,

$$\Delta V_{SL} = K \times R_{SL} \tag{14}$$

$K = 40 \mu\text{A}$ typically and changes slightly as the switching frequency changes. [Figure 24](#) shows the effect the current K has on ΔV_{SL} and different values of R_{SL} as the switching frequency changes.

A more general equation for the slope compensation ramp, M_C , is shown below to include ΔV_{SL} caused by the resistor R_{SL} .

$$M_C = (V_{SL} + \Delta V_{SL}) \times f_S \tag{15}$$

Feature Description (continued)

It is good design practice to only add as much slope compensation as needed to avoid subharmonic oscillation. Additional slope compensation minimizes the influence of the sensed current in the control loop. With very large slope compensation the control loop characteristics are similar to a voltage mode regulator which compares the error voltage to a saw tooth waveform rather than the inductor current.

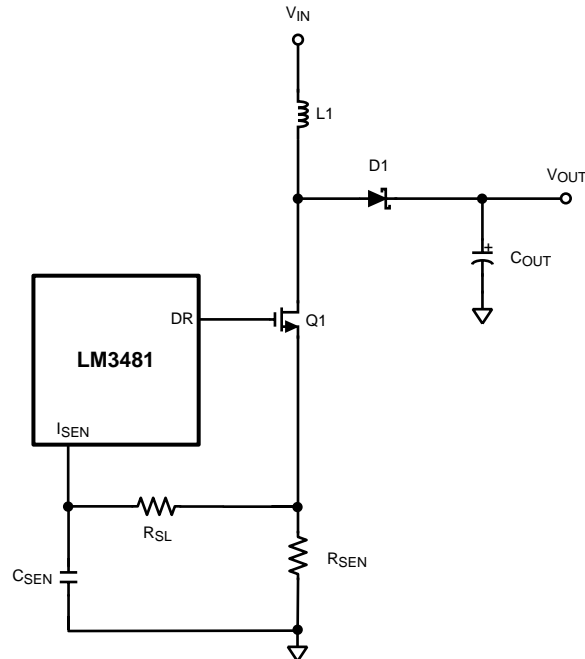

Figure 23. Increasing the Slope of the Compensation Ramp

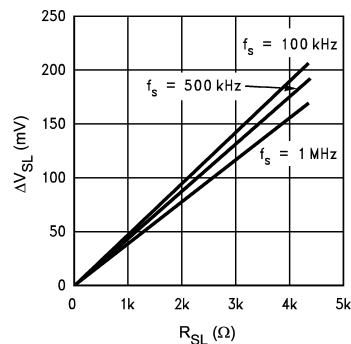

Figure 24. ΔV_{SL} vs R_{SL}

7.3.4 Frequency Adjust, Synchronization, and Shutdown

The switching frequency of the LM3481 can be adjusted between 100 kHz and 1 MHz using a single external resistor. This resistor must be connected between the FA/SYNC/SD pin and ground, as shown in Figure 25. Refer to the *Typical Characteristics* to determine the value of the resistor required for a desired switching frequency.

Equation 16 can also be used to estimate the frequency adjust resistor.

Where f_S is in kHz and R_{FA} in k Ω .

$$R_{FA} = \frac{22 \times 10^3}{f_S} - 5.74 \quad (16)$$

Feature Description (continued)

The LM3481 can be synchronized to an external clock. The external clock must be connected between the FA/SYNC/SD pin and ground, as shown in [Figure 26](#). The frequency adjust resistor may remain connected while synchronizing a signal, therefore if there is a loss of signal, the switching frequency will be set by the frequency adjust resistor.

It is also necessary to have the width of the synchronization pulse wider than the duty cycle of the converter and to have the synchronization pulse width ≥ 300 ns.

The FA/SYNC/SD pin also functions as a shutdown pin. If a high signal (refer to the [Electrical Characteristics](#) section for definition of high signal) appears on the FA/SYNC/SD pin, the LM3481 stops switching and goes into a low current mode. The total supply current of the IC reduces to 5 μ A, typically, under these conditions.

[Figure 27](#) and [Figure 28](#) show an implementation of a shutdown function when operating in frequency adjust mode and synchronization mode, respectively. In frequency adjust mode, connecting the FA/SYNC/SD pin to ground forces the clock to run at a certain frequency. Pulling this pin high shuts down the IC. In frequency adjust or synchronization mode, a high signal for more than 30 μ s shuts down the IC.

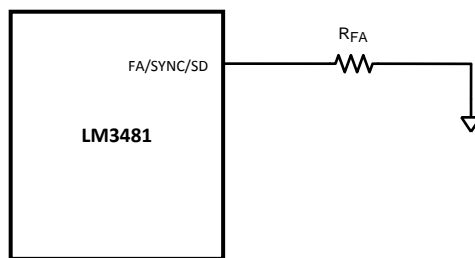

Figure 25. Frequency Adjust

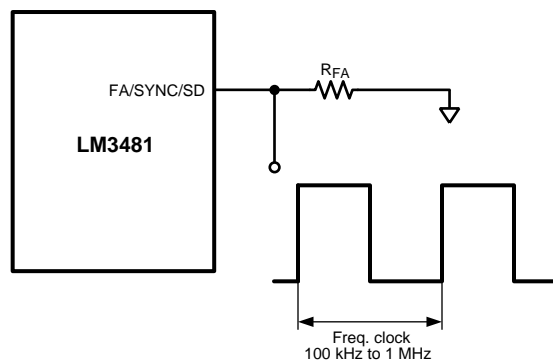

Figure 26. Frequency Synchronization

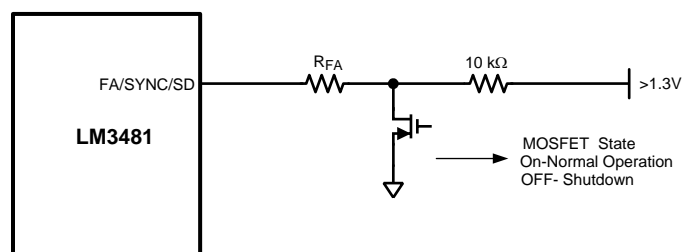

Figure 27. Shutdown Operation in Frequency Adjust Mode

Feature Description (continued)

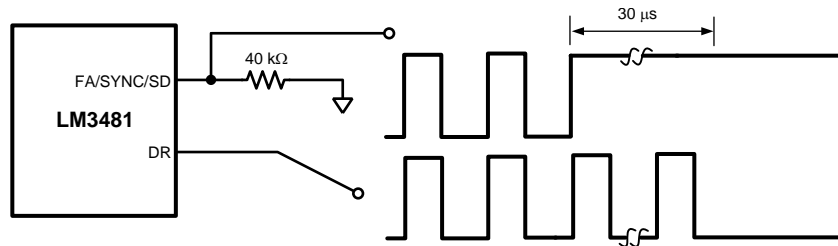

Figure 28. Shutdown Operation in Synchronization Mode

7.3.5 Undervoltage Lockout (UVLO) Pin

The UVLO pin provides user programmable enable and shutdown thresholds. The UVLO pin is compared to an internal reference of 1.43 V (typical), and a resistor divider programs the enable threshold, V_{EN} . When the IC is enabled, a 5- μ A current is sourced out of the UVLO pin, which effectively causes a hysteresis, and the UVLO shutdown threshold, V_{SH} , is now lower than the enable threshold. Setting these thresholds requires two resistors connected from the V_{IN} pin to the UVLO pin and from the UVLO pin to GND (see Figure 29). Select the desired enable, V_{EN} , and UVLO shutdown, V_{SH} , threshold voltages and use the Equation 17 and Equation 18 to determine the resistance values:

$$R8 = \frac{1.43V}{I_{UVLO}} \times \left(1 + \frac{1.43V - V_{SH}}{V_{EN} - 1.43V} \right) \quad (17)$$

$$R7 = R8 \times \left(\frac{V_{EN}}{1.43V} - 1 \right) \quad (18)$$

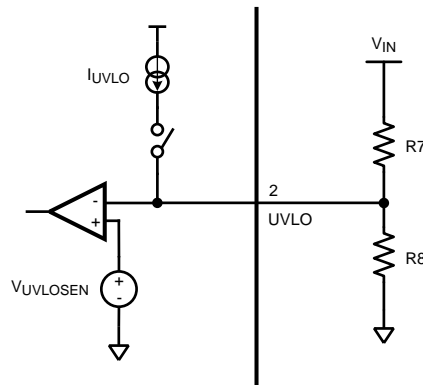

Figure 29. UVLO Pin Resistor Divider

If the system is designed to work over wide input voltages, the voltage at the UVLO pin could exceed the voltage limit for the UVLO pin. In this case a zener diode can be connected between the UVLO pin and ground to prevent the UVLO voltage from rising above the maximum value.

If the UVLO pin function is not desired, select R8 and R7 of equal magnitude greater than 100 k Ω . This will allow V_{IN} to be in control of the UVLO thresholds. The UVLO pin may also be used to implement the enable/disable function. If a signal pulls the UVLO pin below the 1.43 V (typical) threshold, the converter will be disabled.

7.3.6 Short-Circuit Protection

When the voltage across the sense resistor (measured on the I_{SEN} Pin) exceeds 220 mV, short-circuit current limit gets activated. A comparator inside the LM3481 reduces the switching frequency by a factor of 8 and maintains this condition until the short is removed.

7.4 Device Functional Modes

The device is set to run as soon as the input voltage crosses above the UVLO set point and at a frequency set according to the FA/SYNC/SD pin pull-down resistor or to run at a frequency set by the waveform applied to the FA/SYNC/SD pin.

If the FA/SYNC/SD pin is pulled high, the LM3481 enters shut-down mode.

8 Application and Implementation

NOTE

Information in the following applications sections is not part of the TI component specification, and TI does not warrant its accuracy or completeness. TI's customers are responsible for determining suitability of components for their purposes. Customers should validate and test their design implementation to confirm system functionality.

8.1 Application Information

The LM3481 may be operated in either continuous or discontinuous conduction mode. The following applications are designed for continuous conduction operation. This mode of operation has higher efficiency and lower EMI characteristics than the discontinuous mode.

8.2 Typical Applications

8.2.1 Boost Converter

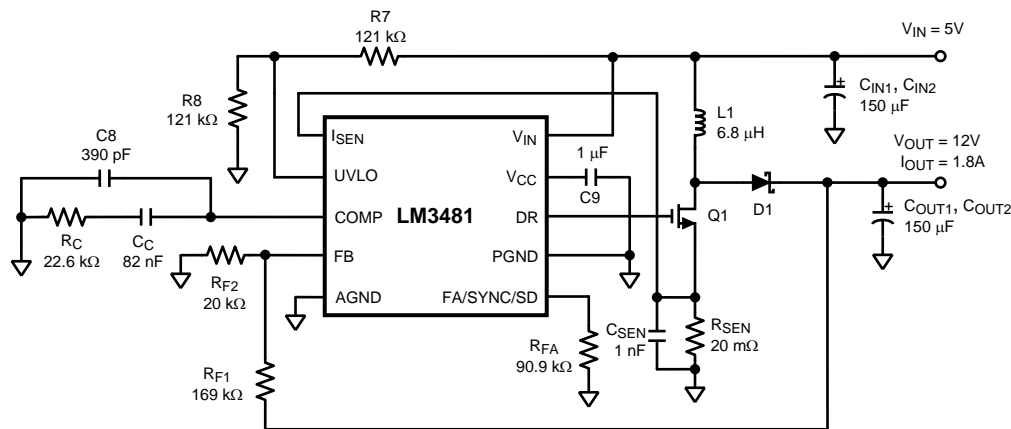

Figure 30. Typical High Efficiency Step-Up (Boost) Converter using LM3481

The most common topology for the LM3481 is the boost or step-up topology. The boost converter converts a low input voltage into a higher output voltage. The basic configuration for a boost regulator is shown in Figure 31. In continuous conduction mode (when the inductor current never reaches zero at steady state), the boost regulator operates in two cycles. In the first cycle of operation, MOSFET Q is turned on and energy is stored in the inductor. During this cycle, diode D1 is reverse biased and load current is supplied by the output capacitor, C_{OUT}.

In the second cycle, MOSFET Q is off and the diode is forward biased. The energy stored in the inductor is transferred to the load and output capacitor. The ratio of these two cycles determines the output voltage. The output voltage is defined as:

$$V_{OUT} = \frac{V_{IN}}{1-D} \quad (19)$$

(ignoring the voltage drop across the MOSFET and the diode), or

$$V_{OUT} + V_{D1} - V_Q = \frac{V_{IN} - V_Q}{1-D} \quad (20)$$

where D is the duty cycle of the switch, V_{D1} is the forward voltage drop of the diode, and V_Q is the drop across the MOSFET when it is on. The following sections describe selection of components for a boost converter.

Typical Applications (continued)

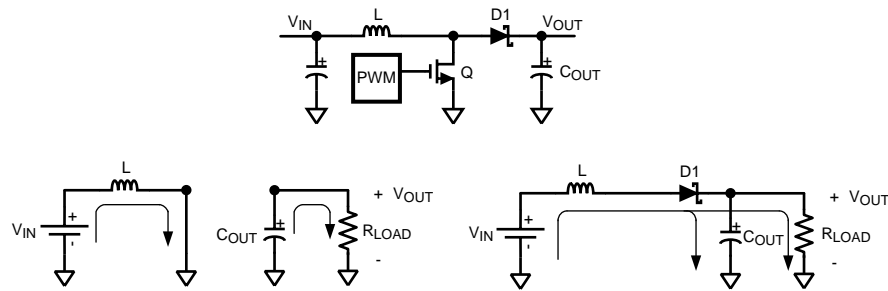

- A. First Cycle of Operation
 B. Second Cycle of Operation

Figure 31. Simplified Boost Converter Diagram

8.2.1.1 Design Requirements

To properly size the components for the application, the designer needs the following parameters: Input voltage range, output voltage, output current range and required switching frequency. These four main parameters will affect the choices of component available to achieve a proper system behavior.

8.2.1.2 Detailed Design Procedure

8.2.1.2.1 Custom Design with WEBENCH Tools

[Click here](#) to create a custom design using the LM3481 device with the WEBENCH® Power Designer.

1. Start by entering your V_{IN} , V_{OUT} and I_{OUT} requirements.
2. Optimize your design for key parameters like efficiency, footprint and cost using the optimizer dial and compare this design with other possible solutions from Texas Instruments.
3. WEBENCH Power Designer provides you with a customized schematic along with a list of materials with real time pricing and component availability.
4. In most cases, you will also be able to:
 - Run electrical simulations to see important waveforms and circuit performance,
 - Run thermal simulations to understand the thermal performance of your board,
 - Export your customized schematic and layout into popular CAD formats,
 - Print PDF reports for the design, and share your design with colleagues.
5. Get more information about WEBENCH tools at www.ti.com/webench.

8.2.1.2.2 Power Inductor Selection

The inductor is one of the two energy storage elements in a boost converter. [Figure 32](#) shows how the inductor current varies during a switching cycle. The current through an inductor is quantified as:

$$V_L(t) = L \frac{di_L(t)}{dt} \quad (21)$$

Typical Applications (continued)

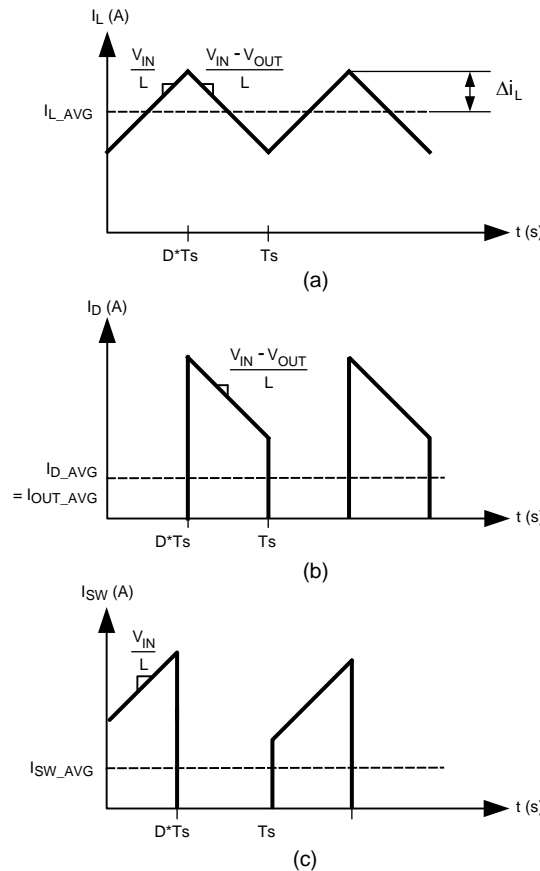

Figure 32. (a) Inductor Current (b) Diode Current (c) Switch Current

If $V_L(t)$ is constant, $di_L(t)/dt$ must be constant. Hence, for a given input voltage and output voltage, the current in the inductor changes at a constant rate.

The important quantities in determining a proper inductance value are I_L (the average inductor current) and Δi_L (the inductor current ripple difference between the peak inductor current and the average inductor current). If Δi_L is larger than I_L , the inductor current drops to zero for a portion of the cycle and the converter operates in discontinuous conduction mode. If Δi_L is smaller than I_L , the inductor current stays above zero and the converter operates in continuous conduction mode. All the analysis in this data sheet assumes operation in continuous conduction mode. To operate in continuous conduction mode, the following conditions must be met:

$$I_L > \Delta i_L \tag{22}$$

$$\frac{I_{OUT}}{1-D} > \frac{DV_{IN}}{2f_s L} \tag{23}$$

$$L > \frac{D(1-D)V_{IN}}{2I_{OUT}f_s} \tag{24}$$

Choose the minimum I_{OUT} to determine the minimum L . A common choice is to set $(2 \times \Delta i_L)$ to 30% of I_L . Choosing an appropriate core size for the inductor involves calculating the average and peak currents expected through the inductor. In a boost converter,

$$I_L = \frac{I_{OUT}}{1-D} \tag{25}$$

$$I_{L_peak} = I_L(max) + \Delta i_L(max) \tag{26}$$

$$\Delta i_L = \frac{DV_{IN}}{2Lf_s} \tag{27}$$

Typical Applications (continued)

A core size with ratings higher than these values should be chosen. If the core is not properly rated, saturation will dramatically reduce overall efficiency.

The LM3481 can be set to switch at very high frequencies. When the switching frequency is high, the converter can operate with very small inductor values. With a small inductor value, the peak inductor current can be extremely higher than the output currents, especially under light load conditions.

The LM3481 senses the peak current through the switch. The peak current through the switch is the same as the peak current calculated above.

8.2.1.2.3 Programming the Output Voltage and Output Current

The output voltage can be programmed using a resistor divider between the output and the feedback pins, as shown in [Figure 33](#). The resistors are selected such that the voltage at the feedback pin is 1.275 V. R_{F1} and R_{F2} can be selected using the equation,

$$V_{OUT} = 1.275 \left(1 + \frac{R_{F1}}{R_{F2}}\right) \quad (28)$$

A 100-pF capacitor may be connected between the feedback and ground pins to reduce noise.

The maximum amount of current that can be delivered at the output can be controlled by the sense resistor, R_{SEN} . Current limit occurs when the voltage that is generated across the sense resistor equals the current sense threshold voltage, V_{SENSE} . Limits for V_{SENSE} have been specified in the [Electrical Characteristics](#) section. This can be expressed as:

$$I_{sw(peak)} \times R_{SEN} = V_{SENSE} - D \times V_{SL} \quad (29)$$

The peak current through the switch is equal to the peak inductor current.

$$I_{sw(peak)} = I_L(max) + \Delta I_L \quad (30)$$

Therefore for a boost converter,

$$I_{sw(peak)} = \frac{I_{OUT(max)}}{(1-D)} + \frac{(D \times V_{IN})}{(2 \times f_s \times L)} \quad (31)$$

Combining the two equations yields an expression for R_{SEN} ,

$$R_{SEN} = \frac{V_{SENSE} - (D \times V_{SL})}{\left[\frac{I_{OUT(max)}}{(1-D)} + \frac{(D \times V_{IN})}{(2 \times f_s \times L)} \right]} \quad (32)$$

Evaluate R_{SEN} at the maximum and minimum V_{IN} values and choose the smallest R_{SEN} calculated.

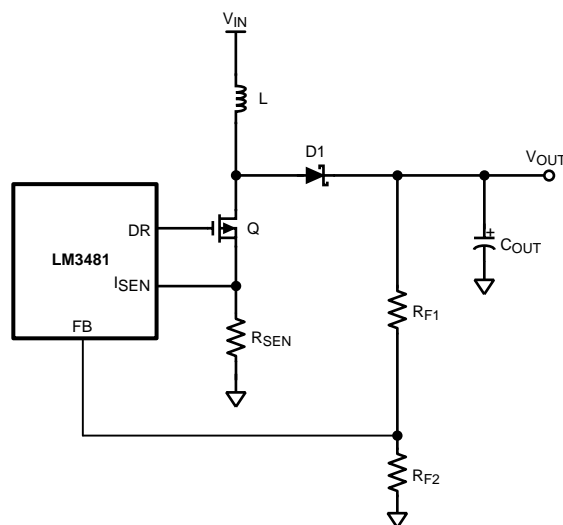

Figure 33. Adjusting the Output Voltage

Typical Applications (continued)

8.2.1.2.4 Current Limit With Additional Slope Compensation

If an external slope compensation resistor is used (see [Figure 23](#)) the internal control signal will be modified and this will have an effect on the current limit.

If R_{SL} is used, then this will add to the existing slope compensation. The command voltage, V_{CS} , will then be given by:

$$V_{CS} = V_{SENSE} - D \times (V_{SL} + \Delta V_{SL}) \quad (33)$$

Where V_{SENSE} is a defined parameter in the [Electrical Characteristics](#) section and ΔV_{SL} is the additional slope compensation generated as discussed in the [Slope Compensation Ramp](#) section. This changes the equation for R_{SEN} to:

$$R_{SEN} = \frac{V_{SENSE} - D \times (V_{SL} + \Delta V_{SL})}{\frac{I_{OUT(max)}}{(1-D)} + \frac{(D \times V_{IN})}{(2 \times f_s \times L)}} \quad (34)$$

Note that because $\Delta V_{SL} = R_{SL} \times K$ as defined earlier, R_{SL} can be used to provide an additional method for setting the current limit. In some designs R_{SL} can also be used to help filter noise to keep the I_{SEN} pin quiet.

8.2.1.2.5 Power Diode Selection

Observation of the boost converter circuit shows that the average current through the diode is the average load current, and the peak current through the diode is the peak current through the inductor. The diode should be rated to handle more than the inductor peak current. The peak diode current can be calculated using the formula:

$$I_{D(Peak)} = [I_{OUT} / (1-D)] + \Delta i_L \quad (35)$$

In [Equation 35](#), I_{OUT} is the output current and Δi_L has been defined in [Figure 32](#).

The peak reverse voltage for a boost converter is equal to the regulator output voltage. The diode must be capable of handling this peak reverse voltage. To improve efficiency, a low forward drop Schottky diode is recommended.

8.2.1.2.6 Power MOSFET Selection

The drive pin, DR, of the LM3481 must be connected to the gate of an external MOSFET. In a boost topology, the drain of the external N-Channel MOSFET is connected to the inductor and the source is connected to the ground. The drive pin voltage, V_{DR} , depends on the input voltage (see [Typical Characteristics](#)). In most applications, a logic level MOSFET can be used. For very low input voltages, a sub-logic level MOSFET should be used.

The selected MOSFET directly controls the efficiency. The critical parameters for selection of a MOSFET are:

- Minimum threshold voltage, $V_{TH(MIN)}$
- On-resistance, $R_{DS(ON)}$
- Total gate charge, Q_g
- Reverse transfer capacitance, C_{RSS}
- Maximum drain to source voltage, $V_{DS(MAX)}$

The off-state voltage of the MOSFET is approximately equal to the output voltage. $V_{DS(MAX)}$ of the MOSFET must be greater than the output voltage. The power losses in the MOSFET can be categorized into conduction losses and ac switching or transition losses. $R_{DS(ON)}$ is needed to estimate the conduction losses. The conduction loss, P_{COND} , is the I^2R loss across the MOSFET. The maximum conduction loss is given by:

$$P_{COND(MAX)} = \left(\frac{I_{OUT(max)}}{1 - D_{MAX}} \right)^2 D_{MAX} R_{DS(ON)} \quad (36)$$

where D_{MAX} is the maximum duty cycle.

$$D_{MAX} = \left(1 - \frac{V_{IN(MIN)}}{V_{OUT}} \right) \quad (37)$$

At high switching frequencies the switching losses may be the largest portion of the total losses.

Typical Applications (continued)

The switching losses are very difficult to calculate due to changing parasitics of a given MOSFET in operation. Often, the individual MOSFET datasheet does not give enough information to yield a useful result. Equation 38 and Equation 39 give a rough idea how the switching losses are calculated:

$$P_{SW} = \frac{I_{Lmax} \times V_{out}}{2} \times f_{SW} \times (t_{LH} + t_{HL}) \quad (38)$$

$$t_{LH} = \left(Q_{gd} + \frac{Q_{gs}}{2} \right) \times \frac{R_{Gate}}{V_{DR} - V_{GSth}} \quad (39)$$

8.2.1.2.7 Input Capacitor Selection

Due to the presence of an inductor at the input of a boost converter, the input current waveform is continuous and triangular, as shown in Figure 32. The inductor ensures that the input capacitor sees fairly low ripple currents. However, as the input capacitor gets smaller, the input ripple goes up. The rms current in the input capacitor is given by:

$$I_{CIN(RMS)} = \Delta i_L / \sqrt{3} = \left(\frac{(V_{OUT} - V_{IN})V_{IN}}{\sqrt{12} V_{OUT} L f_s} \right) \quad (40)$$

The input capacitor should be capable of handling the rms current. Although the input capacitor is not as critical in a boost application, low values can cause impedance interactions. Therefore a good quality capacitor should be chosen in the range of 100 μ F to 200 μ F. If a value lower than 100 μ F is used, then problems with impedance interactions or switching noise can affect the LM3481. To improve performance, especially with V_{IN} below 8 V, it is recommended to use a 20 Ω resistor at the input to provide a RC filter. This resistor is placed in series with the V_{IN} pin with only a bypass capacitor attached to the V_{IN} pin directly (see Figure 34). A 0.1- μ F or 1- μ F ceramic capacitor is necessary in this configuration. The bulk input capacitor and inductor will connect on the other side of the resistor with the input power supply.

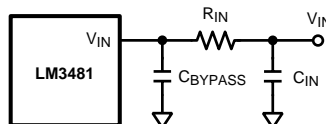

Figure 34. Reducing IC Input Noise

8.2.1.2.8 Output Capacitor Selection

The output capacitor in a boost converter provides all the output current when the inductor is charging. As a result it sees very large ripple currents. The output capacitor should be capable of handling the maximum rms current. The rms current in the output capacitor is:

$$I_{COUT(RMS)} = \sqrt{(1-D) \left[I_{OUT}^2 \frac{D}{(1-D)^2} + \frac{\Delta i_L^2}{3} \right]} \quad (41)$$

Where

$$\Delta i_L = \frac{D V_{IN}}{2 L f_s} \quad (42)$$

and D, the duty cycle is equal to $(V_{OUT} - V_{IN})/V_{OUT}$.

The ESR and ESL of the output capacitor directly control the output ripple. Use capacitors with low ESR and ESL at the output for high efficiency and low ripple voltage. Surface mount tantalums, surface mount polymer electrolytic and polymer tantalum, Sanyo- OSCON, or multi-layer ceramic capacitors are recommended at the output.

8.2.1.2.9 Driver Supply Capacitor Selection

A good quality ceramic bypass capacitor must be connected from the V_{CC} pin to the PGND pin for proper operation. This capacitor supplies the transient current required by the internal MOSFET driver, as well as filtering the internal supply voltage for the controller. A value of between 0.47 μ F and 4.7 μ F is recommended.

Typical Applications (continued)

8.2.1.2.10 Compensation

For detailed explanation on how to select the right compensation components to attach to the compensation pin for a boost topology please see *AN-1286 Compensation for the LM3478 Boost Controller (SNVA067)*. When calculating the Error Amplifier DC gain, A_{EA} , $R_{OUT} = 152\text{ k}\Omega$ for the LM3481.

8.2.1.3 Application Curve

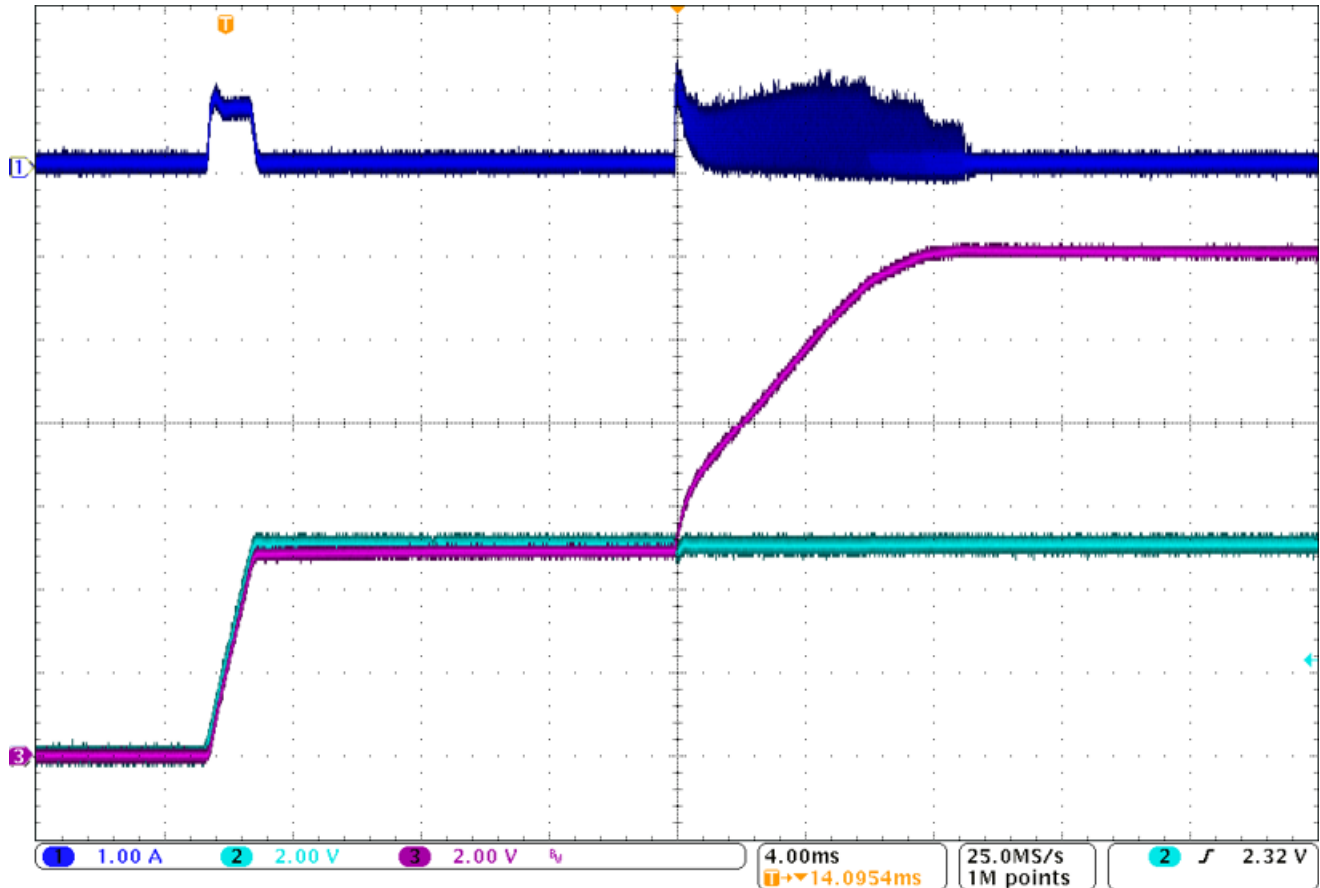

Figure 35. Start-Up Pattern for a 5-Vin, 12-Vout Boost Converter Using LM3481 Boost Evaluation Module (C1: Inductor Current, C2: Vin, C3:Vout)

Typical Applications (continued)

8.2.2 Typical SEPIC Converter

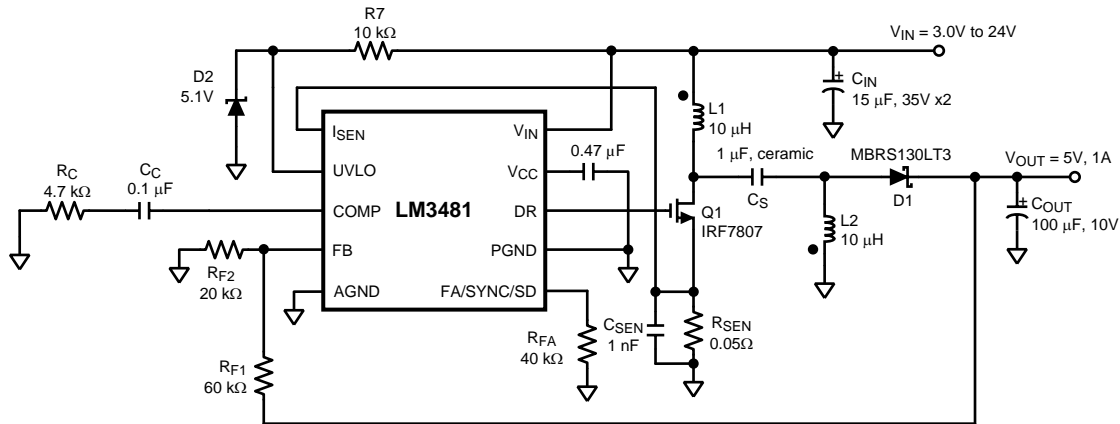

Figure 36. Typical SEPIC Converter using LM3481

Because the LM3481 controls a low-side N-Channel MOSFET, it can also be used in SEPIC (Single Ended Primary Inductance Converter) applications. An example of SEPIC using the LM3481 is shown in [Figure 36](#). As shown in [Figure 36](#), the output voltage can be higher or lower than the input voltage. The SEPIC uses two inductors to step-up or step-down the input voltage. The inductors L1 and L2 can be two discrete inductors or two windings of a coupled transformer because equal voltages are applied across the inductor throughout the switching cycle. Using two discrete inductors allows use of catalog magnetics, as opposed to a custom transformer. The input ripple can be reduced along with size by using the coupled windings of transformer for L1 and L2.

Due to the presence of the inductor L1 at the input, the SEPIC inherits all the benefits of a boost converter. One main advantage of SEPIC over a boost converter is the inherent input to output isolation. The capacitor C_S isolates the input from the output and provides protection against shorted or malfunctioning load. Hence, the SEPIC is useful for replacing boost circuits when true shutdown is required. This means that the output voltage falls to 0V when the switch is turned off. In a boost converter, the output can only fall to the input voltage minus a diode drop.

The duty cycle of a SEPIC is given by:

$$D = \frac{V_{OUT} + V_{DIODE}}{V_{OUT} + V_{IN} - V_Q + V_{DIODE}} \quad (43)$$

In [Equation 43](#), V_Q is the on-state voltage of the MOSFET, Q1, and V_{DIODE} is the forward voltage drop of the diode.

8.2.2.1 Design Requirements

To properly size the components for the application, the designer needs the following parameters: Input voltage range, output voltage, output current range and required switching frequency. These four main parameters will affect the choices of component available to achieve a proper system behavior.

8.2.2.2 Detailed Design Procedure

8.2.2.2.1 Power MOSFET Selection

As in a boost converter, the parameters governing the selection of the MOSFET are the minimum threshold voltage, $V_{TH(MIN)}$, the on-resistance, $R_{DS(ON)}$, the total gate charge, Q_g , the reverse transfer capacitance, C_{RSS} , and the maximum drain to source voltage, $V_{DS(MAX)}$. The peak switch voltage in a SEPIC is given by:

$$V_{SW(PEAK)} = V_{IN} + V_{OUT} + V_{DIODE} \quad (44)$$

The selected MOSFET should satisfy the condition:

$$V_{DS(MAX)} > V_{SW(PEAK)} \quad (45)$$

Typical Applications (continued)

The peak switch current is given by:

$$I_{SWPEAK} = I_{L1(AVG)} + I_{OUT} + \frac{\Delta I_{L1} + \Delta I_{L2}}{2} \quad (46)$$

Where ΔI_{L1} and ΔI_{L2} are the peak-to-peak inductor ripple currents of inductors L1 and L2 respectively.

The rms current through the switch is given by:

$$I_{SWRMS} = \sqrt{\left[I_{SWPEAK}^2 - I_{SWPEAK} (\Delta I_{L1} + \Delta I_{L2}) + \frac{(\Delta I_{L1} + \Delta I_{L2})^2}{3} \right] D} \quad (47)$$

8.2.2.2.2 Power Diode Selection

The Power diode must be selected to handle the peak current and the peak reverse voltage. In a SEPIC, the diode peak current is the same as the switch peak current. The off-state voltage or peak reverse voltage of the diode is $V_{IN} + V_{OUT}$. Similar to the boost converter, the average diode current is equal to the output current. Schottky diodes are recommended.

8.2.2.2.3 Selection of Inductors L1 and L2

Proper selection of the inductors L1 and L2 to maintain constant current mode requires calculations of the following parameters.

Average current in the inductors:

$$I_{L1AVE} = \frac{D I_{OUT}}{1-D} \quad (48)$$

$$I_{L2AVE} = I_{OUT} \quad (49)$$

Peak-to-peak ripple current, to calculate core loss if necessary:

$$\Delta I_{L1} = \frac{(V_{IN} - V_Q) D}{(L1) f_s} \quad (50)$$

$$\Delta I_{L2} = \frac{(V_{IN} - V_Q) D}{(L2) f_s} \quad (51)$$

Maintaining the condition $I_L > \Delta I_L / 2$ to ensure continuous conduction mode yields the following minimum values for L1 and L2:

$$L1 > \frac{(V_{IN} - V_Q)(1-D)}{2 I_{OUT} f_s} \quad (52)$$

$$L2 > \frac{(V_{IN} - V_Q) D}{2 I_{OUT} f_s} \quad (53)$$

Peak current in the inductor, to ensure the inductor does not saturate:

$$I_{L1PK} = \frac{D I_{OUT}}{1-D} + \frac{\Delta I_{L1}}{2} \quad (54)$$

$$I_{L2PK} = I_{OUT} + \frac{\Delta I_{L2}}{2} \quad (55)$$

I_{L1PK} must be lower than the maximum current rating set by the current sense resistor.

The value of L1 can be increased above the minimum recommended value to reduce input ripple and output ripple. However, once ΔI_{L1} is less than 20% of I_{L1AVE} , the benefit to output ripple is minimal.

By increasing the value of L2 above the minimum recommendation, ΔI_{L2} can be reduced, which in turn will reduce the output ripple voltage:

$$\Delta V_{OUT} = \left(\frac{I_{OUT}}{1-D} + \frac{\Delta I_{L2}}{2} \right) ESR \quad (56)$$

where ESR is the effective series resistance of the output capacitor.

Typical Applications (continued)

If L1 and L2 are wound on the same core, then $L1 = L2 = L$. All the equations above will hold true if the inductance is replaced by $2L$. A good choice for transformer with equal turns is Coiltronics CTX series Octopack.

8.2.2.2.4 Sense Resistor Selection

The peak current through the switch, I_{SWPEAK} , can be adjusted using the current sense resistor, R_{SEN} , to provide a certain output current. Resistor R_{SEN} can be selected using the formula:

$$R_{SEN} = \frac{V_{SENSE} - D \times (V_{SL} + \Delta V_{SL})}{I_{SWPEAK}} \quad (57)$$

8.2.2.2.5 SEPIC Capacitor Selection

The selection of SEPIC capacitor, C_S , depends on the rms current. The rms current of the SEPIC capacitor is given by:

$$I_{CSRMS} = \sqrt{I_{SWRMS}^2 + (I_{L1PK}^2 - I_{L1PK}\Delta I_{L1} + \Delta I_{L1}^2)(1-D)} \quad (58)$$

The SEPIC capacitor must be rated for a large ACrms current relative to the output power. This property makes the SEPIC much better suited to lower power applications where the rms current through the capacitor is small (relative to capacitor technology). The voltage rating of the SEPIC capacitor must be greater than the maximum input voltage. Tantalum capacitors are the best choice for SMT, having high rms current ratings relative to size. Ceramic capacitors could be used, but the low C values will tend to cause larger changes in voltage across the capacitor due to the large currents, and high C value ceramics are expensive. Electrolytics work well for through hole applications where the size required to meet the rms current rating can be accommodated. There is an energy balance between C_S and L1, which can be used to determine the value of the capacitor. The basic energy balance equation is:

$$\frac{1}{2}C_S\Delta V_S^2 = \frac{1}{2}(L1)\Delta I_{L1}^2 \quad (59)$$

Where

$$\Delta V_S = \left(\frac{V_{OUT}}{V_{OUT} + V_{IN} - V_O + V_{DIODE}} \right) \frac{I_{OUT}}{f_S C_S} \quad (60)$$

is the ripple voltage across the SEPIC capacitor, and

$$\Delta I_{L1} = \frac{(V_{IN} - V_O) D}{(L1)f_S} \quad (61)$$

is the ripple current through the inductor L1. The energy balance equation can be solved to provide a minimum value for C_S :

$$C_S \geq L1 \frac{I_{OUT}^2}{(V_{IN} - V_O)^2} \quad (62)$$

8.2.2.2.6 Input Capacitor Selection

Similar to a boost converter, the SEPIC has an inductor at the input. Hence, the input current waveform is continuous and triangular. The inductor ensures that the input capacitor sees fairly low ripple currents. However, as the input capacitor gets smaller, the input ripple goes up. The rms current in the input capacitor is given by:

$$I_{CIN(RMS)} = \Delta I_{L1} / \sqrt{12} = \frac{D}{2\sqrt{3}} \left(\frac{V_{IN} - V_O}{(L1)f_S} \right) \quad (63)$$

The input capacitor should be capable of handling the rms current. Although the input capacitor is not as critical in a SEPIC application, low values can cause impedance interactions. Therefore a good quality capacitor should be chosen in the range of 100 μ F to 200 μ F. If a value lower than 100 μ F is used, then problems with impedance interactions or switching noise can affect the LM3481. To improve performance, especially with V_{IN} below 8 V, it is recommended to use a 20 Ω resistor at the input to provide a RC filter. This resistor is placed in series with the V_{IN} pin with only a bypass capacitor attached to the V_{IN} pin directly (see [Figure 34](#)). A 0.1 μ F or 1 μ F ceramic capacitor is necessary in this configuration. The bulk input capacitor and inductor will connect on the other side of the resistor with the input power supply.

Typical Applications (continued)

8.2.2.2.7 Output Capacitor Selection

The output capacitor of the SEPIC sees very large ripple currents similar to the output capacitor of a boost converter. The rms current through the output capacitor is given by:

$$I_{RMS} = \sqrt{\left[I_{SWPEAK}^2 - I_{SWPEAK} (\Delta I_{L1} + \Delta I_{L2}) + \frac{(\Delta I_{L1} + \Delta I_{L2})^2}{3} \right] (1-D) - I_{OUT}^2} \quad (64)$$

The ESR and ESL of the output capacitor directly control the output ripple. Use capacitors with low ESR and ESL at the output for high efficiency and low ripple voltage. Surface mount tantalums, surface mount polymer electrolytic and polymer tantalum, Sanyo- OSCON, or multi-layer ceramic capacitors are recommended at the output for low ripple.

8.2.2.3 Application Curve

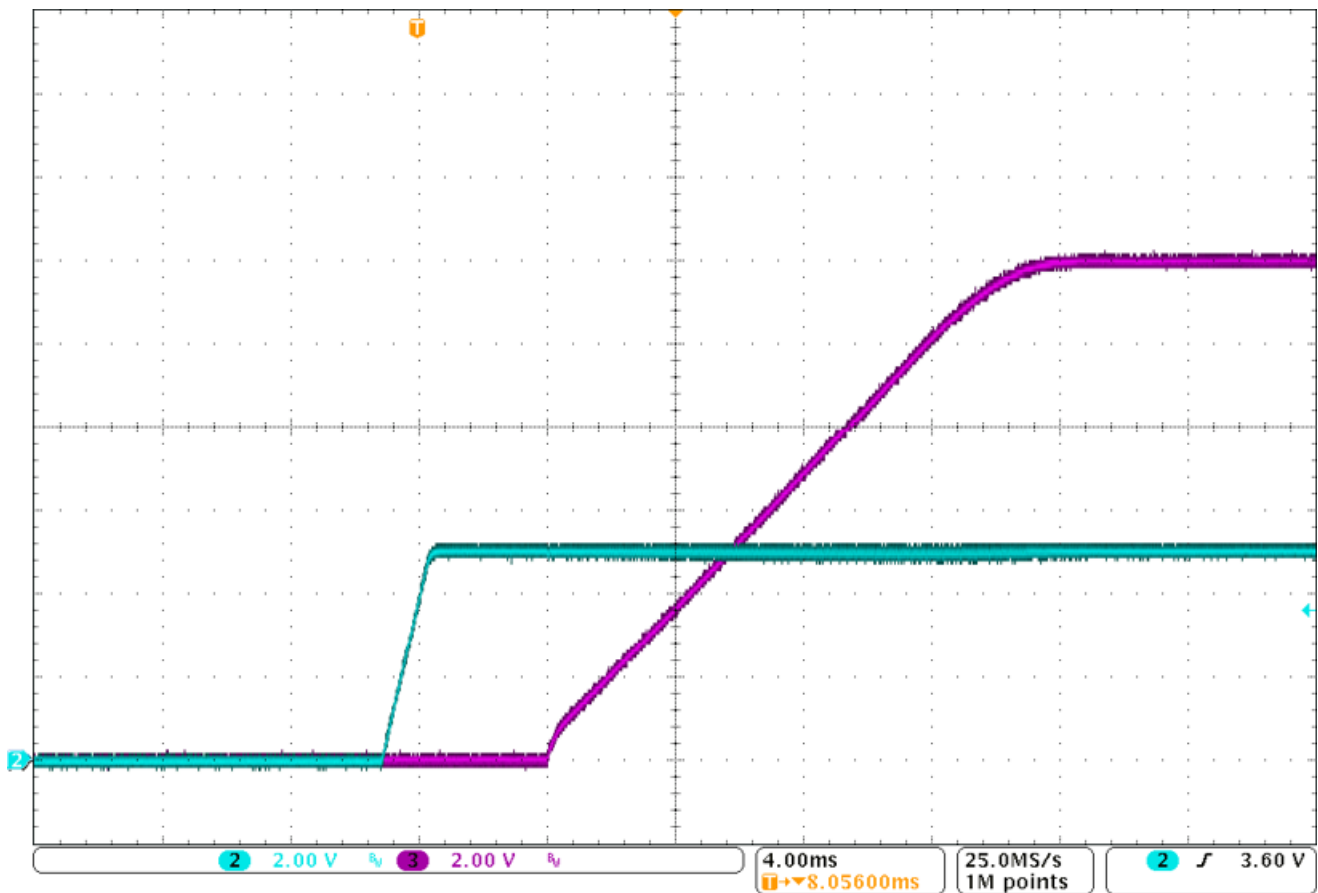

Figure 37. Start-Up Pattern for a 5-Vin, 12-Vout SEPIC Converter on LM3481 SEPIC Evaluation Module (C2: Vin, C3:Vout)

9 Power Supply Recommendations

The LM3481 is designed to operate from various DC power supply including a car battery. If so, VIN input should be protected from reversal voltage and voltage dump over 48 Volts. The impedance of the input supply rail should be low enough that the input current transient does not cause drop below VIN UVLO level. If the input supply is connected by using long wires, additional bulk capacitance may be required in addition to normal input capacitor.

10 Layout

10.1 Layout Guidelines

Good board layout is critical for switching controllers such as the LM3481. First the ground plane area must be sufficient for thermal dissipation purposes and second, appropriate guidelines must be followed to reduce the effects of switching noise. Switch mode converters are very fast switching devices. In such devices, the rapid increase of input current combined with the parasitic trace inductance generates unwanted Ldi/dt noise spikes. The magnitude of this noise tends to increase as the output current increases. This parasitic spike noise may turn into electromagnetic interference (EMI), and can also cause problems in device performance. Therefore, care must be taken in layout to minimize the effect of this switching noise. The current sensing circuit in current mode devices can be easily effected by switching noise. This noise can cause duty cycle jitter which leads to increased spectral noise. Although the LM3481 has 250 ns blanking time at the beginning of every cycle to ignore this noise, some noise may remain after the blanking time.

The most important layout rule is to keep the AC current loops as small as possible. [Figure 38](#) shows the current flow of a boost converter. The top schematic shows a dotted line which represents the current flow during on-state and the middle schematic shows the current flow during off-state. The bottom schematic shows the currents we refer to as AC currents. These currents are the most critical currents because current is changing in very short time periods. The dotted lined traces of the bottom schematic are the once to make as short as possible.

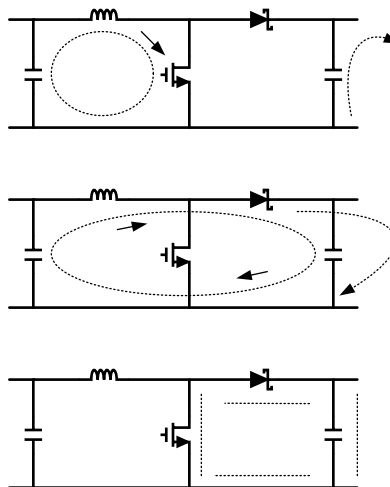

Figure 38. Current Flow in a Boost Application

The PGND and AGND pins have to be connected to the same ground very close to the IC. To avoid ground loop currents attach all the grounds of the system only at one point.

A ceramic input capacitor should be connected as close as possible to the Vin pin and grounded close to the GND pin.

For a layout example please see *AN-2094 LM3481 SEPIC Evaluation Board* ([SNVA461](#)). For more information about layout in switch mode power supplies refer to *AN-1229 SIMPLE SWITCHER® PCB Layout Guidelines* ([SNVA054](#)).

10.2 Layout Example

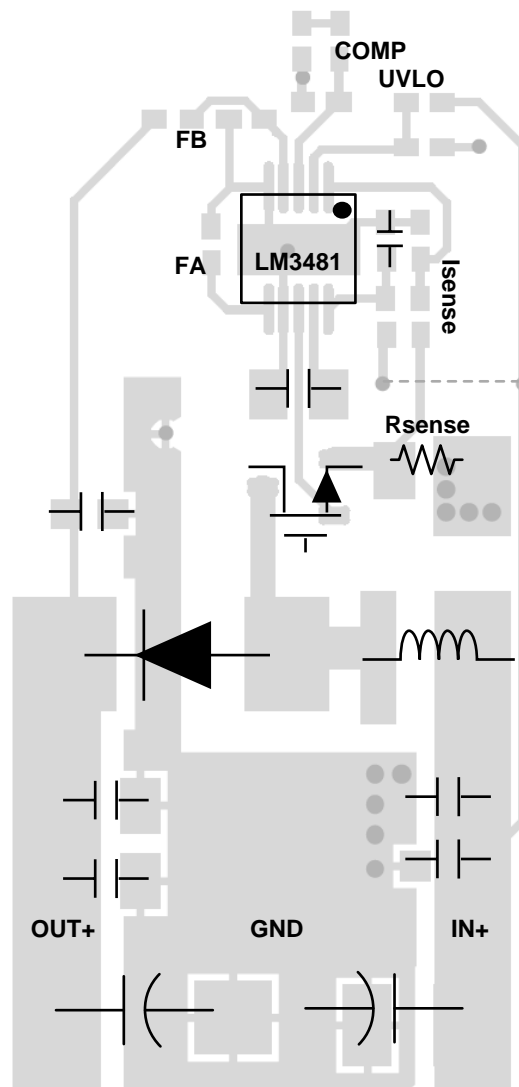

Figure 39. Typical Layout for a Boost Converter

11 Device and Documentation Support

11.1 Documentation Support

11.1.1 Custom Design with WEBENCH Tools

[Click here](#) to create a custom design using the LM3481 device with the WEBENCH® Power Designer.

1. Start by entering your V_{IN} , V_{OUT} and I_{OUT} requirements.
2. Optimize your design for key parameters like efficiency, footprint and cost using the optimizer dial and compare this design with other possible solutions from Texas Instruments.
3. WEBENCH Power Designer provides you with a customized schematic along with a list of materials with real time pricing and component availability.
4. In most cases, you will also be able to:
 - Run electrical simulations to see important waveforms and circuit performance,
 - Run thermal simulations to understand the thermal performance of your board,
 - Export your customized schematic and layout into popular CAD formats,
 - Print PDF reports for the design, and share your design with colleagues.
5. Get more information about WEBENCH tools at www.ti.com/webench.

11.1.2 Receiving Notification of Documentation Updates

To receive notification of documentation updates, navigate to the device product folder on ti.com. In the upper right corner, click on *Alert me* to register and receive a weekly digest of any product information that has changed. For change details, review the revision history included in any revised document.

11.1.3 Related Documentation

- *AN-1286 Compensation for the LM3478 Boost Controller* ([SNVA067](#))
- *AN-2094 LM3481 SEPIC Evaluation Board* ([SNVA461](#))
- *AN-1229 SIMPLE SWITCHER® PCB Layout Guidelines* ([SNVA054](#))
- *SNVU111 330mW AC or DC Tiny Flyback Converter Power Supply* ([SNVU111](#))

11.2 Related Links

The table below lists quick access links. Categories include technical documents, support and community resources, tools and software, and quick access to sample or buy.

Table 1. Related Links

PARTS	PRODUCT FOLDER	SAMPLE & BUY	TECHNICAL DOCUMENTS	TOOLS & SOFTWARE	SUPPORT & COMMUNITY
LM3481	Click here	Click here	Click here	Click here	Click here
LM3481-Q1	Click here	Click here	Click here	Click here	Click here

11.3 Trademarks

WEBENCH is a registered trademark of Texas Instruments.

11.4 Electrostatic Discharge Caution



These devices have limited built-in ESD protection. The leads should be shorted together or the device placed in conductive foam during storage or handling to prevent electrostatic damage to the MOS gates.

11.5 Glossary

[SLYZ022](#) — *TI Glossary*.

This glossary lists and explains terms, acronyms, and definitions.

12 Mechanical, Packaging, and Orderable Information

The following pages include mechanical, packaging, and orderable information. This information is the most current data available for the designated devices. This data is subject to change without notice and revision of this document. For browser-based versions of this data sheet, refer to the left-hand navigation.

PACKAGING INFORMATION

Orderable Device	Status (1)	Package Type	Package Drawing	Pins	Package Qty	Eco Plan (2)	Lead/Ball Finish (6)	MSL Peak Temp (3)	Op Temp (°C)	Device Marking (4/5)	Samples
LM3481MM/NOPB	ACTIVE	VSSOP	DGS	10	1000	Green (RoHS & no Sb/Br)	CU NIPDAUAG CU SN	Level-1-260C-UNLIM	-40 to 125	SJPB	Samples
LM3481MMX/NOPB	ACTIVE	VSSOP	DGS	10	3500	Green (RoHS & no Sb/Br)	CU NIPDAUAG CU SN	Level-1-260C-UNLIM	-40 to 125	SJPB	Samples
LM3481QMM/NOPB	ACTIVE	VSSOP	DGS	10	1000	Green (RoHS & no Sb/Br)	CU SN	Level-1-260C-UNLIM	-40 to 125	SUAB	Samples
LM3481QMMX/NOPB	ACTIVE	VSSOP	DGS	10	3500	Green (RoHS & no Sb/Br)	CU SN	Level-1-260C-UNLIM	-40 to 125	SUAB	Samples

(1) The marketing status values are defined as follows:

ACTIVE: Product device recommended for new designs.

LIFEBUY: TI has announced that the device will be discontinued, and a lifetime-buy period is in effect.

NRND: Not recommended for new designs. Device is in production to support existing customers, but TI does not recommend using this part in a new design.

PREVIEW: Device has been announced but is not in production. Samples may or may not be available.

OBSELETE: TI has discontinued the production of the device.

(2) Eco Plan - The planned eco-friendly classification: Pb-Free (RoHS), Pb-Free (RoHS Exempt), or Green (RoHS & no Sb/Br) - please check <http://www.ti.com/productcontent> for the latest availability information and additional product content details.

TBD: The Pb-Free/Green conversion plan has not been defined.

Pb-Free (RoHS): TI's terms "Lead-Free" or "Pb-Free" mean semiconductor products that are compatible with the current RoHS requirements for all 6 substances, including the requirement that lead not exceed 0.1% by weight in homogeneous materials. Where designed to be soldered at high temperatures, TI Pb-Free products are suitable for use in specified lead-free processes.

Pb-Free (RoHS Exempt): This component has a RoHS exemption for either 1) lead-based flip-chip solder bumps used between the die and package, or 2) lead-based die adhesive used between the die and leadframe. The component is otherwise considered Pb-Free (RoHS compatible) as defined above.

Green (RoHS & no Sb/Br): TI defines "Green" to mean Pb-Free (RoHS compatible), and free of Bromine (Br) and Antimony (Sb) based flame retardants (Br or Sb do not exceed 0.1% by weight in homogeneous material)

(3) MSL, Peak Temp. - The Moisture Sensitivity Level rating according to the JEDEC industry standard classifications, and peak solder temperature.

(4) There may be additional marking, which relates to the logo, the lot trace code information, or the environmental category on the device.

(5) Multiple Device Markings will be inside parentheses. Only one Device Marking contained in parentheses and separated by a "~" will appear on a device. If a line is indented then it is a continuation of the previous line and the two combined represent the entire Device Marking for that device.

(6) Lead/Ball Finish - Orderable Devices may have multiple material finish options. Finish options are separated by a vertical ruled line. Lead/Ball Finish values may wrap to two lines if the finish value exceeds the maximum column width.

Important Information and Disclaimer: The information provided on this page represents TI's knowledge and belief as of the date that it is provided. TI bases its knowledge and belief on information provided by third parties, and makes no representation or warranty as to the accuracy of such information. Efforts are underway to better integrate information from third parties. TI has taken and continues to take reasonable steps to provide representative and accurate information but may not have conducted destructive testing or chemical analysis on incoming materials and chemicals. TI and TI suppliers consider certain information to be proprietary, and thus CAS numbers and other limited information may not be available for release.

In no event shall TI's liability arising out of such information exceed the total purchase price of the TI part(s) at issue in this document sold by TI to Customer on an annual basis.

OTHER QUALIFIED VERSIONS OF LM3481, LM3481-Q1 :

- Catalog: [LM3481](#)
- Automotive: [LM3481-Q1](#)

NOTE: Qualified Version Definitions:

- Catalog - TI's standard catalog product
- Automotive - Q100 devices qualified for high-reliability automotive applications targeting zero defects

TAPE AND REEL INFORMATION



QUADRANT ASSIGNMENTS FOR PIN 1 ORIENTATION IN TAPE



*All dimensions are nominal

Device	Package Type	Package Drawing	Pins	SPQ	Reel Diameter (mm)	Reel Width W1 (mm)	A0 (mm)	B0 (mm)	K0 (mm)	P1 (mm)	W (mm)	Pin1 Quadrant
LM3481MM/NOPB	VSSOP	DGS	10	1000	178.0	12.4	5.3	3.4	1.4	8.0	12.0	Q1
LM3481MMX/NOPB	VSSOP	DGS	10	3500	330.0	12.4	5.3	3.4	1.4	8.0	12.0	Q1
LM3481QMM/NOPB	VSSOP	DGS	10	1000	178.0	12.4	5.3	3.4	1.4	8.0	12.0	Q1
LM3481QMMX/NOPB	VSSOP	DGS	10	3500	330.0	12.4	5.3	3.4	1.4	8.0	12.0	Q1

TAPE AND REEL BOX DIMENSIONS

*All dimensions are nominal

Device	Package Type	Package Drawing	Pins	SPQ	Length (mm)	Width (mm)	Height (mm)
LM3481MM/NOPB	VSSOP	DGS	10	1000	210.0	185.0	35.0
LM3481MMX/NOPB	VSSOP	DGS	10	3500	367.0	367.0	35.0
LM3481QMM/NOPB	VSSOP	DGS	10	1000	210.0	185.0	35.0
LM3481QMMX/NOPB	VSSOP	DGS	10	3500	367.0	367.0	35.0

DGS0010A



PACKAGE OUTLINE

VSSOP - 1.1 mm max height

SMALL OUTLINE PACKAGE

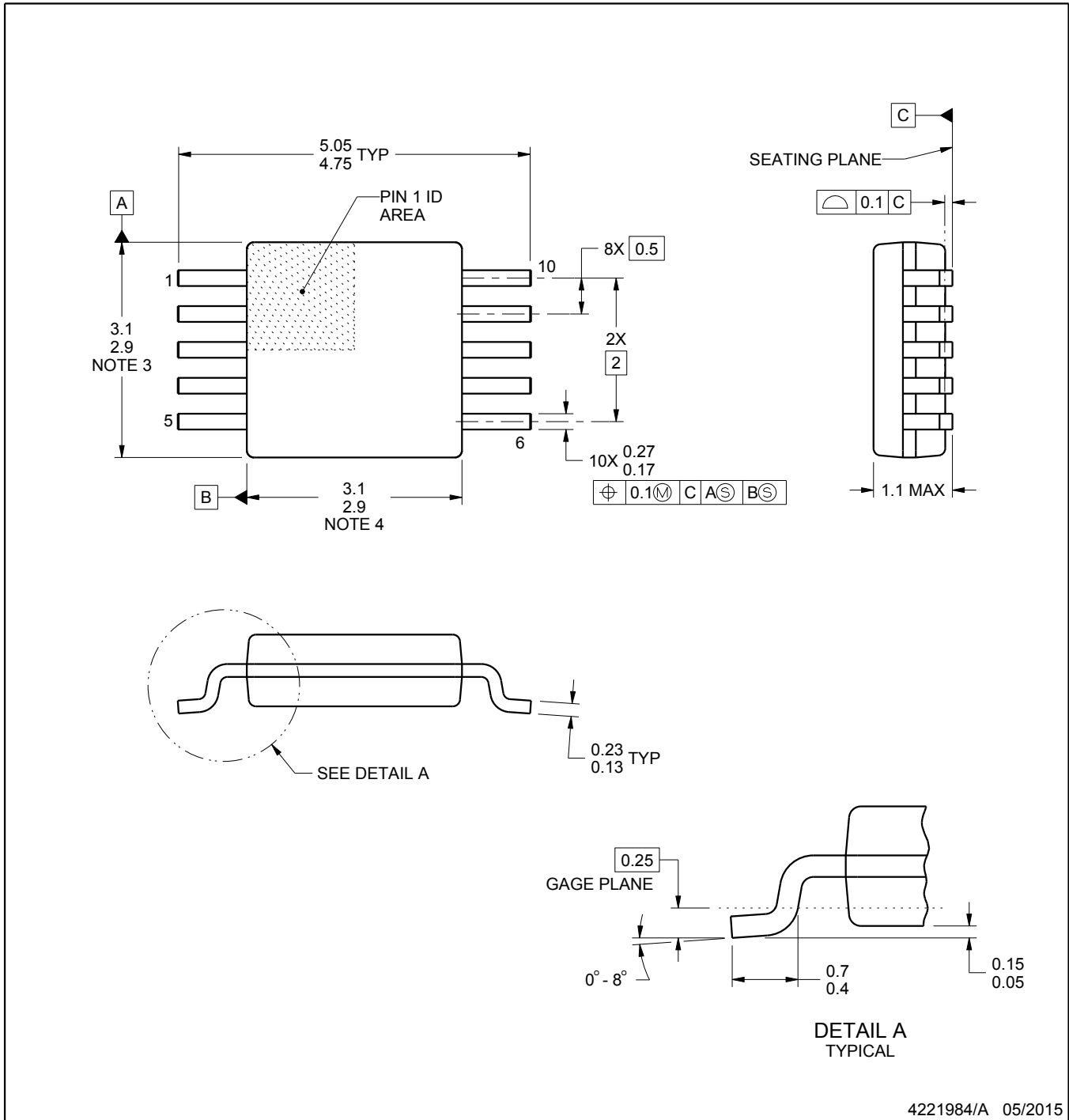

4221984/A 05/2015

NOTES:

1. All linear dimensions are in millimeters. Any dimensions in parenthesis are for reference only. Dimensioning and tolerancing per ASME Y14.5M.
2. This drawing is subject to change without notice.
3. This dimension does not include mold flash, protrusions, or gate burrs. Mold flash, protrusions, or gate burrs shall not exceed 0.15 mm per side.
4. This dimension does not include interlead flash. Interlead flash shall not exceed 0.25 mm per side.
5. Reference JEDEC registration MO-187, variation BA.

EXAMPLE BOARD LAYOUT

DGS0010A

VSSOP - 1.1 mm max height

SMALL OUTLINE PACKAGE



LAND PATTERN EXAMPLE
SCALE:10X

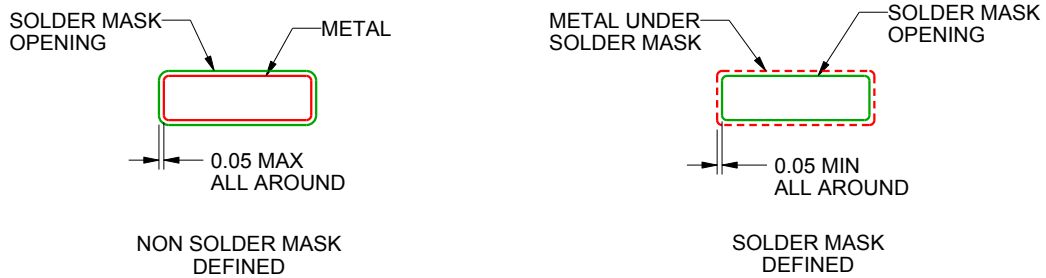

SOLDER MASK DETAILS
NOT TO SCALE

4221984/A 05/2015

NOTES: (continued)

- 6. Publication IPC-7351 may have alternate designs.
- 7. Solder mask tolerances between and around signal pads can vary based on board fabrication site.

EXAMPLE STENCIL DESIGN

DGS0010A

VSSOP - 1.1 mm max height

SMALL OUTLINE PACKAGE



SOLDER PASTE EXAMPLE
BASED ON 0.125 mm THICK STENCIL
SCALE:10X

4221984/A 05/2015

NOTES: (continued)

8. Laser cutting apertures with trapezoidal walls and rounded corners may offer better paste release. IPC-7525 may have alternate design recommendations.
9. Board assembly site may have different recommendations for stencil design.

IMPORTANT NOTICE AND DISCLAIMER

TI PROVIDES TECHNICAL AND RELIABILITY DATA (INCLUDING DATASHEETS), DESIGN RESOURCES (INCLUDING REFERENCE DESIGNS), APPLICATION OR OTHER DESIGN ADVICE, WEB TOOLS, SAFETY INFORMATION, AND OTHER RESOURCES "AS IS" AND WITH ALL FAULTS, AND DISCLAIMS ALL WARRANTIES, EXPRESS AND IMPLIED, INCLUDING WITHOUT LIMITATION ANY IMPLIED WARRANTIES OF MERCHANTABILITY, FITNESS FOR A PARTICULAR PURPOSE OR NON-INFRINGEMENT OF THIRD PARTY INTELLECTUAL PROPERTY RIGHTS.

These resources are intended for skilled developers designing with TI products. You are solely responsible for (1) selecting the appropriate TI products for your application, (2) designing, validating and testing your application, and (3) ensuring your application meets applicable standards, and any other safety, security, or other requirements. These resources are subject to change without notice. TI grants you permission to use these resources only for development of an application that uses the TI products described in the resource. Other reproduction and display of these resources is prohibited. No license is granted to any other TI intellectual property right or to any third party intellectual property right. TI disclaims responsibility for, and you will fully indemnify TI and its representatives against, any claims, damages, costs, losses, and liabilities arising out of your use of these resources.

TI's products are provided subject to TI's Terms of Sale (www.ti.com/legal/termsofsale.html) or other applicable terms available either on ti.com or provided in conjunction with such TI products. TI's provision of these resources does not expand or otherwise alter TI's applicable warranties or warranty disclaimers for TI products.

Mailing Address: Texas Instruments, Post Office Box 655303, Dallas, Texas 75265
Copyright © 2018, Texas Instruments Incorporated

Looking for pricing, stock, or lifecycle information?

Click below to explore more details on WIN SOURCE:

 [View LM3481QMMX/NOPB on WIN SOURCE](#)

 [Texas Instruments](#) Information

Optimize Your Supply Chain with WIN SOURCE Solutions

-  Global Sourcing Solution
-  Obsolete Management
-  Cost Control Management
-  Shortage Management
-  Alternative Solution
-  Excess Inventory Management