



# THE DATASHEET OF THS4511RGTT





## WIDEBAND, LOW-NOISE, LOW-DISTORTION, FULLY-DIFFERENTIAL AMPLIFIER

Check for Samples: [THS4511](#)

### FEATURES

- Fully-Differential Architecture
- Common-Mode Input Range Includes the Negative Rail
- Unity-Gain Stable
- Bandwidth: 1.6 GHz (Gain = 0 dB)
- Slew Rate: 4900 V/ $\mu$ s
- 1% Settling Time: 3.3 ns
- HD<sub>2</sub>: –72 dBc at 70 MHz
- HD<sub>3</sub>: –87 dBc at 70 MHz
- OIP<sub>2</sub>: 76 dBm at 70 MHz
- OIP<sub>3</sub>: 42 dBm at 70 MHz
- Input Voltage Noise: 2 nV/ $\sqrt{\text{Hz}}$  ( $f > 10$  MHz)
- Noise Figure: 21.8 dB (50- $\Omega$  System, G = 6 dB)
- Output Common-Mode Control
- 5-V Power-Supply Current: 39.2 mA
- Power-Down Capability: 0.65 mA

### APPLICATIONS

- 5-V Data-Acquisition Systems
- High Linearity ADC Amplifiers
- Wireless Communication
- Medical Imaging
- Test and Measurement

### RELATED PRODUCTS

DEVICE	MIN. GAIN	COMMON-MODE RANGE OF INPUT <sup>(1)</sup>
THS4508	6 dB	–0.3 V to 2.3 V
THS4509	6 dB	0.75 V to 4.25 V
THS4511	0 dB	–0.3 V to 2.3 V
THS4513	0 dB	0.75 V to 4.25 V

1. Assumes a 5-V single-ended power supply.

### DESCRIPTION

The THS4511 is a wideband, fully-differential operational amplifier designed for single-supply 5-V data-acquisition systems. It has very low noise at 2 nV/ $\sqrt{\text{Hz}}$ , and extremely low harmonic distortion of –72 dBc HD<sub>2</sub> and –87 dBc HD<sub>3</sub> at 70 MHz with 2 V<sub>PP</sub>, G = 0 dB, and 200- $\Omega$  load. Slew rate is very high at 4900 V/ $\mu$ s and with settling time of 3.3 ns to 1% (2 V step) it is ideal for pulsed applications. It is designed for minimum gain of 0 dB.

To allow for dc coupling to analog-to-digital converters (ADCs), its unique output common-mode control circuit maintains the output common-mode voltage within 5-mV offset (typical) from the set voltage, when set within  $\pm 0.5$  V of midsupply. The common-mode set point is set to midsupply by internal circuitry, which may be over-driven from an external source.

The THS4511 is a high-performance amplifier that has been optimized for use in 5-V single-supply data acquisition systems. The output has been optimized for best performance with its common-mode voltages set to midsupply, and the input has been optimized for performance over a wide range of common-mode input voltages. High performance at a low power-supply voltage enables single-supply 5-V data-acquisition systems while minimizing component count.

The THS4511 is offered in a quad, 16-pin leadless QFN package (RGT), and is characterized for operation over the full industrial temperature range from –40°C to +85°C.

#### Video Buffer, Single-Ended to Differential

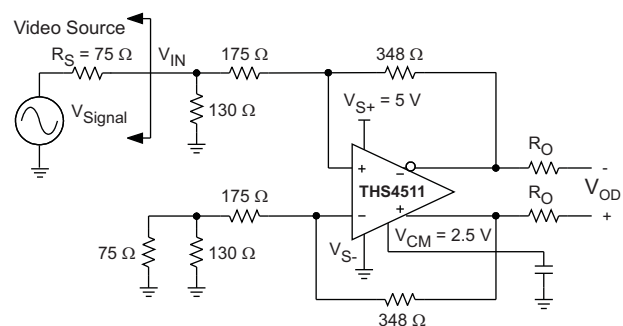

Please be aware that an important notice concerning availability, standard warranty, and use in critical applications of Texas Instruments semiconductor products and disclaimers thereto appears at the end of this data sheet.

PowerPAD is a trademark of Texas Instruments Incorporated.



This integrated circuit can be damaged by ESD. Texas Instruments recommends that all integrated circuits be handled with appropriate precautions. Failure to observe proper handling and installation procedures can cause damage.

ESD damage can range from subtle performance degradation to complete device failure. Precision integrated circuits may be more susceptible to damage because very small parametric changes could cause the device not to meet its published specifications.

## ABSOLUTE MAXIMUM RATINGS<sup>(1)</sup>

Over operating free-air temperature range, unless otherwise noted.

			UNIT
V <sub>SS</sub>	Supply voltage	V <sub>S-</sub> to V <sub>S+</sub>	5.5 V
V <sub>I</sub>	Input voltage		±V <sub>S</sub>
V <sub>ID</sub>	Differential input voltage		4 V
I <sub>O</sub>	Output current		200 mA
Continuous power dissipation			See <a href="#">Dissipation Ratings Table</a>
T <sub>J</sub>	Maximum junction temperature <sup>(2)</sup>		+150°C
T <sub>J</sub>	Maximum junction temperature, continuous operation, long term reliability <sup>(3)</sup>		+125°C
T <sub>A</sub>	Operating free-air temperature range		–40°C to +85°C
T <sub>STG</sub>	Storage temperature range		–65°C to +150°C
ESD ratings	HBM		2000 V
	CDM		1500 V
	MM		100 V

- (1) Stresses above these ratings may cause permanent damage. Exposure to absolute maximum conditions for extended periods may degrade device reliability. These are stress ratings only, and functional operation of the device at these or any other conditions beyond those specified is not implied.
- (2) The absolute maximum temperature under any condition is limited by the constraints of the silicon process.
- (3) The maximum junction temperature for continuous operation is limited by the package constraints. Operation above this temperature may result in reduced reliability and/or lifetime of the device. The THS4511 incorporates a (QFN) exposed thermal pad on the underside of the chip. This acts as a heatsink and must be connected to a thermally-dissipative plane for proper power dissipation. Failure to do so may result in exceeding the maximum junction temperature which could permanently damage the device. See TI technical brief [SLMA002](#) and [SLMA004](#) for more information about using the QFN thermally-enhanced package.

## DISSIPATION RATINGS TABLE

PACKAGE <sup>(1)</sup>	θ <sub>JC</sub>	θ <sub>JA</sub>	POWER RATING	
			T <sub>A</sub> ≤ +25°C	T <sub>A</sub> = +85°C
RGT (16)	2.4°C/W	39.5°C/W	2.3 W	225 mW

- (1) For the most current package and ordering information, see the Package Option Addendum at the end of this document, or see the TI web site at [www.ti.com](http://www.ti.com).

## DEVICE INFORMATION

**RGT PACKAGE  
16-PIN LEADLESS QFN  
(TOP VIEW)**

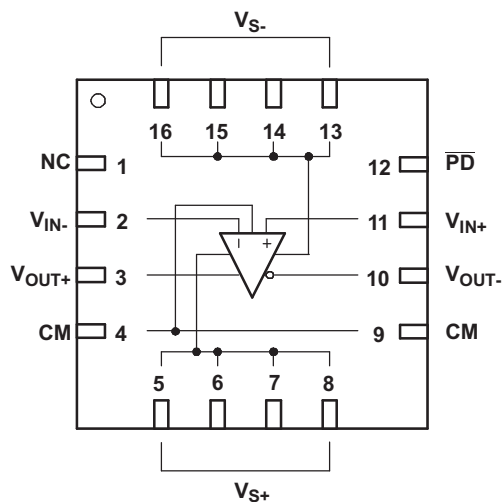

## TERMINAL FUNCTIONS

TERMINAL (RGT PACKAGE)		DESCRIPTION
NO.	NAME	
1	NC	No internal connection
2	$V_{IN-}$	Inverting amplifier input
3	$V_{OUT+}$	Noninverting amplifier output
4, 9	CM	Common-mode voltage input
5-8	$V_{S+}$	Positive amplifier power supply input
10	$V_{OUT-}$	Inverted amplifier output
11	$V_{IN+}$	Noninverting amplifier input
12	$\overline{PD}$	Power-down; $\overline{PD}$ = logic low puts part into low power mode, $\overline{PD}$ = logic high or open for normal operation
13-16	$V_{S-}$	Negative amplifier power-supply input

**ELECTRICAL CHARACTERISTICS:  $V_{S+} - V_{S-} = 5\text{ V}$**

Test conditions unless otherwise noted:  $V_{S+} = 5\text{ V}$ ,  $V_{S-} = 0\text{ V}$ ,  $G = 0\text{ dB}$ ,  $CM = \text{open}$ ,  $V_O = 2\text{ V}_{PP}$ ,  $R_F = 349\ \Omega$ ,  $R_L = 200\ \Omega$  differential,  $T = +25^\circ\text{C}$  single-ended input, differential output, input referenced to ground, and output referenced to midsupply.

PARAMETER	TEST CONDITIONS		THS4511			UNITS	TEST LEVEL <sup>(1)</sup>
			MIN	TYP	MAX		
<b>AC PERFORMANCE (see Figure 38)</b>							
Small-Signal Bandwidth	$G = 0\text{ dB}$ , $V_O = 100\text{ mV}_{PP}$			1.6		GHz	C
	$G = 6\text{ dB}$ , $V_O = 100\text{ mV}_{PP}$			1.4			
Gain-Bandwidth Product				2		GHz	
Bandwidth for 0.1-dB flatness	$G = 0\text{ dB}$ , $V_O = 2\text{ V}_{PP}$			160		MHz	
	$G = 6\text{ dB}$ , $V_O = 2\text{ V}_{PP}$			620			
Large-Signal Bandwidth	$G = 10\text{ dB}$ , $V_O = 2\text{ V}_{PP}$			1.35		GHz	
Slew Rate (Differential)				4900		V/ $\mu\text{s}$	
Rise Time	$V_O = 2\text{-V Step}$			0.5		ns	
Fall Time				0.5		ns	
Settling Time to 1%				3.3		ns	
Settling Time to 0.1%				16		ns	
2 <sup>nd</sup> Order Harmonic Distortion	$f = 10\text{ MHz}$			-117		dBc	
	$f = 50\text{ MHz}$			-80			
	$f = 100\text{ MHz}$			-64			
3 <sup>rd</sup> Order Harmonic Distortion	$f = 10\text{ MHz}$			-106		dBc	
	$f = 50\text{ MHz}$			-92			
	$f = 100\text{ MHz}$			-80			
2 <sup>nd</sup> Order Intermodulation Distortion	200-kHz tone spacing, $R_L = 100\ \Omega$	$f_C = 70\text{ MHz}$		-78		dBc	
3 <sup>rd</sup> Order Intermodulation Distortion		$f_C = 140\text{ MHz}$		-56			
		$f_C = 70\text{ MHz}$		-88			
		$f_C = 140\text{ MHz}$		-71.4			
2 <sup>nd</sup> Order Output Intercept Point	200-kHz tone spacing, $R_L = 100\ \Omega$	$f_C = 70\text{ MHz}$		76.3		dBm	
3 <sup>rd</sup> Order Output Intercept Point		$f_C = 140\text{ MHz}$		53.4			
		$f_C = 70\text{ MHz}$		42			
		$f_C = 140\text{ MHz}$		34			
1-dB Compression Point <sup>(2)</sup>	$f_C = 70\text{ MHz}$			12.2		dBm	
	$f_C = 140\text{ MHz}$			10.8			
Noise Figure	50- $\Omega$ system, 10 MHz			21.8		dB	
Input Voltage Noise	$f > 10\text{ MHz}$			2		nV/ $\sqrt{\text{Hz}}$	
Input Current Noise	$f > 10\text{ MHz}$			1.5		pA/ $\sqrt{\text{Hz}}$	
<b>DC PERFORMANCE</b>							
Open-Loop Voltage Gain ( $A_{OL}$ )				63		dB	C
Input Offset Voltage	$T_A = +25^\circ\text{C}$			1	4	mV	A
	$T_A = -40^\circ\text{C to } +85^\circ\text{C}$			1	5		
Average Offset Voltage Drift				2.3		$\mu\text{V}/^\circ\text{C}$	B
Input Bias Current	$T_A = +25^\circ\text{C}$		1.75	8	15.5	$\mu\text{A}$	A
	$T_A = -40^\circ\text{C to } +85^\circ\text{C}$			8	18.5		
Average Bias Current Drift				20		nA/ $^\circ\text{C}$	B
Input Offset Current	$T_A = +25^\circ\text{C}$			0.5	3.6	$\mu\text{A}$	A
	$T_A = -40^\circ\text{C to } +85^\circ\text{C}$			0.5	7		
Average Offset Current Drift				7		nA/ $^\circ\text{C}$	B

- (1) Test levels: (A) 100% tested at +25°C. Over-temperature limits by characterization and simulation. (B) Limits set by characterization and simulation. (C) Typical value only for information.
- (2) The 1-dB compression point is measured at the load with 50- $\Omega$  double termination. Add 3 dB to refer to amplifier output.

**ELECTRICAL CHARACTERISTICS:  $V_{S+} - V_{S-} = 5\text{ V}$  (continued)**

 Test conditions unless otherwise noted:  $V_{S+} = 5\text{ V}$ ,  $V_{S-} = 0\text{ V}$ ,  $G = 0\text{ dB}$ ,  $CM = \text{open}$ ,  $V_O = 2\text{ V}_{PP}$ ,  $R_F = 349\ \Omega$ ,  $R_L = 200\ \Omega$  differential,  $T = +25^\circ\text{C}$  single-ended input, differential output, input referenced to ground, and output referenced to midsupply.

PARAMETER	TEST CONDITIONS	THS4511			UNITS	TEST LEVEL <sup>(1)</sup>	
		MIN	TYP	MAX			
<b>INPUT</b>							
Common-Mode Input Range High			2.3		V	B	
Common-Mode Input Range Low			-0.3				
Common-Mode Rejection Ratio			90		dB		
Differential Input Impedance			18.2    1.62		M $\Omega$    pF	C	
Common-Mode Input Impedance			4.0    1.73				
<b>OUTPUT</b>							
Maximum Output Voltage High	Each output with 100 $\Omega$ to midsupply	$T_A = +25^\circ\text{C}$	3.7	3.8	V	A	
		$T_A = -40^\circ\text{C}$ to $+85^\circ\text{C}$	3.6	3.8			
Minimum Output Voltage Low		$T_A = +25^\circ\text{C}$		1.2			1.3
		$T_A = -40^\circ\text{C}$ to $+85^\circ\text{C}$		1.2			1.4
Differential Output Voltage Swing	$T_A = +25^\circ\text{C}$	4.8	5.2		V	A	
	$T_A = -40^\circ\text{C}$ to $+85^\circ\text{C}$	4.4	5.2				
Differential Output Current Drive	$R_L = 10\ \Omega$		96		mA	C	
Output Balance Error	$V_O = 100\text{ mV}$ , $f = 1\text{ MHz}$		-52		dB	C	
Closed-Loop Output Impedance	$f = 1\text{ MHz}$		0.3		$\Omega$	C	
<b>OUTPUT COMMON-MODE VOLTAGE CONTROL</b>							
Small-Signal Bandwidth			250		MHz	C	
Slew Rate			110		V/ $\mu\text{s}$		
Gain			1		V/V		
Output Common-Mode Offset from CM Input	$1.25\text{ V} < CM < 3.5\text{ V}$		5		mV		
CM Input Bias Current	$1.25\text{ V} < CM < 3.5\text{ V}$		$\pm 40$		$\mu\text{A}$		
CM Input Voltage Range			1.25 to 3.75		V		
CM Input Impedance			32    1.5		k $\Omega$    pF		
CM Default Voltage	CM pins floating		2.5		V		
<b>POWER SUPPLY</b>							
Specified Operating Voltage		3.75 <sup>(3)</sup>	5	5.25	V	C	
Maximum Quiescent Current	$T_A = +25^\circ\text{C}$		39.2	42.5	mA	A	
	$T_A = -40^\circ\text{C}$ to $+85^\circ\text{C}$		39.2	43.5			
Minimum Quiescent Current	$T_A = +25^\circ\text{C}$	35.9	39.2		mA	A	
	$T_A = -40^\circ\text{C}$ to $+85^\circ\text{C}$	35	39.2				
Power-Supply Rejection ( $\pm\text{PSRR}$ )	To differential output		90		dB	C	
<b>POWER-DOWN</b>							
	Referenced to $V_{S-}$						
Enable Voltage Threshold	Device assured <i>on</i> above 2.1 V		> 2.1		V	C	
Disable Voltage Threshold	Device assured <i>off</i> below 0.7 V		< 0.7				
Power-Down Quiescent Current	$T_A = +25^\circ\text{C}$		0.65	0.9	mA	A	
	$T_A = -40^\circ\text{C}$ to $+85^\circ\text{C}$		0.65	1			
Input Bias Current	$\overline{PD} = V_{S-}$		100		$\mu\text{A}$	C	
Input Impedance			50    2		k $\Omega$    pF		
Turn-On Time Delay	Measured to output on		55		ns		
Turn-Off Time Delay	Measured to output off		10		$\mu\text{s}$		

 (3) See the [Application Information](#) section of this data sheet for device operation with full supply voltages less than 5 V.

## TYPICAL CHARACTERISTICS

Small-Signal Frequency Response	G = 0 dB, $V_{OD} = 100 \text{ mV}_{PP}$		<a href="#">Figure 1</a>
	G = 6 dB, $V_{OD} = 100 \text{ mV}_{PP}$		<a href="#">Figure 2</a>
Large-Signal Frequency Response	G = 0 dB, $V_{OD} = 2 \text{ V}_{PP}$		<a href="#">Figure 3</a>
	G = 6 dB, $V_{OD} = 2 \text{ V}_{PP}$		<a href="#">Figure 4</a>
Harmonic Distortion	HD <sub>2</sub> , G = 0 dB, $V_{OD} = 2 \text{ V}_{PP}$	vs Frequency	<a href="#">Figure 5</a>
	HD <sub>3</sub> , G = 0 dB, $V_{OD} = 2 \text{ V}_{PP}$	vs Frequency	<a href="#">Figure 6</a>
	HD <sub>2</sub> , G = 6 dB, $V_{OD} = 2 \text{ V}_{PP}$	vs Frequency	<a href="#">Figure 7</a>
	HD <sub>3</sub> , G = 6 dB, $V_{OD} = 2 \text{ V}_{PP}$	vs Frequency	<a href="#">Figure 8</a>
	HD <sub>2</sub> , G = 0 dB	vs Output Voltage	<a href="#">Figure 9</a>
	HD <sub>3</sub> , G = 0 dB	vs Output Voltage	<a href="#">Figure 10</a>
	HD <sub>2</sub> , G = 0 dB	vs CM Output Voltage	<a href="#">Figure 11</a>
	HD <sub>3</sub> , G = 0 dB	vs CM Output Voltage	<a href="#">Figure 12</a>
Intermodulation Distortion	IMD <sub>2</sub> , G = 0 dB	vs Frequency	<a href="#">Figure 13</a>
	IMD <sub>3</sub> , G = 0 dB	vs Frequency	<a href="#">Figure 14</a>
Output Intercept Point	OIP <sub>2</sub>	vs Frequency	<a href="#">Figure 15</a>
	OIP <sub>3</sub>	vs Frequency	<a href="#">Figure 16</a>
S-Parameters		vs Frequency	<a href="#">Figure 17</a>
Transition Rate		vs Output Voltage	<a href="#">Figure 18</a>
Transient Response			<a href="#">Figure 19</a>
Settling Time			<a href="#">Figure 20</a>
Rejection Ratio		vs Frequency	<a href="#">Figure 21</a>
Output Impedance		vs Frequency	<a href="#">Figure 22</a>
Overdrive Recovery			<a href="#">Figure 23</a>
Differential Output Voltage	Load Resistance		<a href="#">Figure 24</a>
Turn-Off Time			<a href="#">Figure 25</a>
Turn-On Time			<a href="#">Figure 26</a>
Input Offset Voltage		vs Input Common-Mode Voltage	<a href="#">Figure 27</a>
Open-Loop Gain and Phase		vs Frequency	<a href="#">Figure 28</a>
Input-Referred Noise		vs Frequency	<a href="#">Figure 29</a>
Noise Figure		vs Frequency	<a href="#">Figure 30</a>
Quiescent Current		vs Supply Voltage	<a href="#">Figure 31</a>
Output Balance Error		vs Frequency	<a href="#">Figure 32</a>
CM Input Impedance		vs Frequency	<a href="#">Figure 33</a>
CM Small-Signal Frequency Response			<a href="#">Figure 34</a>
CM Input Bias Current		vs CM Input Voltage	<a href="#">Figure 35</a>
Differential Output Offset Voltage		vs CM Input Voltage	<a href="#">Figure 36</a>
Output Common-Mode Offset		vs CM Input Voltage	<a href="#">Figure 37</a>

**TYPICAL CHARACTERISTICS:  $V_{S+} - V_{S-} = 5\text{ V}$**

Test conditions unless otherwise noted:  $V_{S+} = 5\text{ V}$ ,  $V_{S-} = 0\text{ V}$ ,  $G = 0\text{ dB}$ ,  $CM = \text{open}$ ,  $V_O = 2\text{ V}_{PP}$ ,  $R_F = 349\ \Omega$ ,  $R_L = 200\ \Omega$  differential, single-ended input, input referenced to ground, and output referenced to midrail.

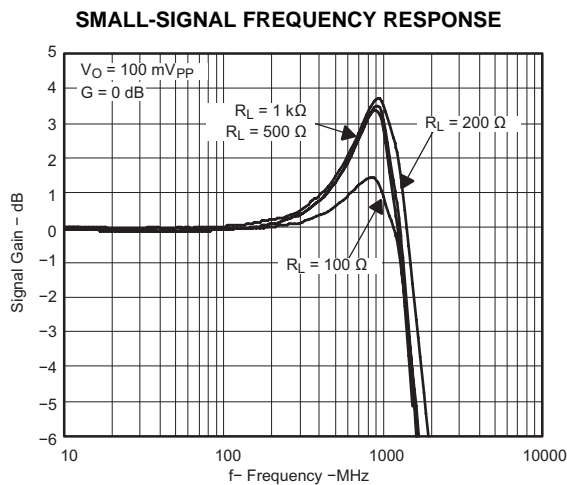

Figure 1.

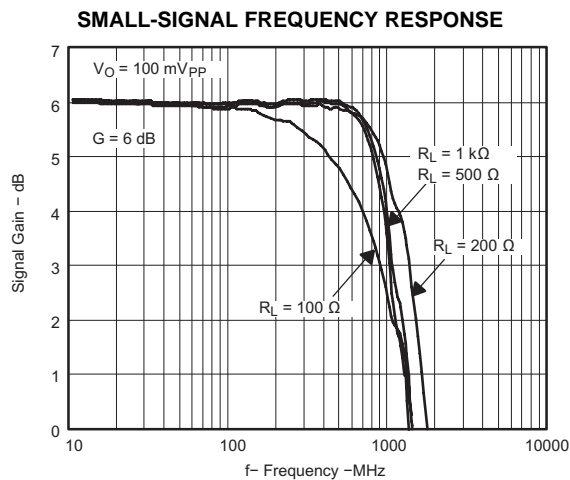

Figure 2.

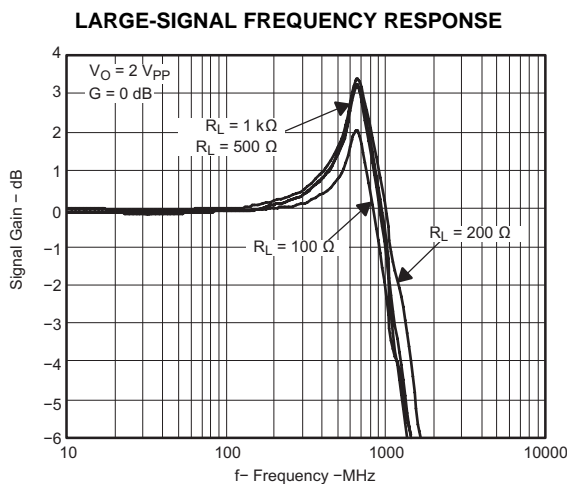

Figure 3.

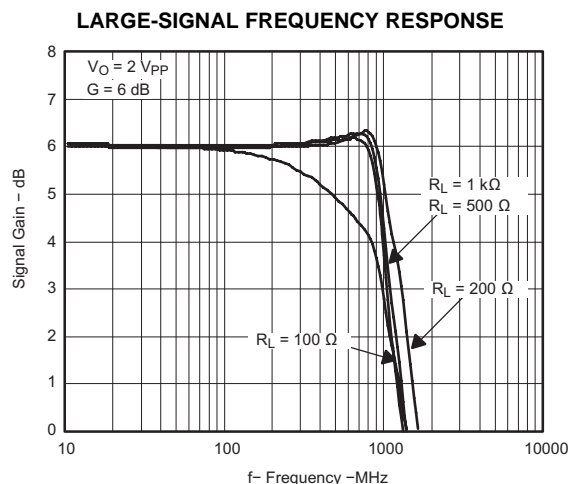

Figure 4.

**TYPICAL CHARACTERISTICS:  $V_{S+} - V_{S-} = 5\text{ V}$  (continued)**

Test conditions unless otherwise noted:  $V_{S+} = 5\text{ V}$ ,  $V_{S-} = 0\text{ V}$ ,  $G = 0\text{ dB}$ , CM = open,  $V_O = 2\text{ V}_{PP}$ ,  $R_F = 349\ \Omega$ ,  $R_L = 200\ \Omega$  differential, single-ended input, input referenced to ground, and output referenced to midrail.

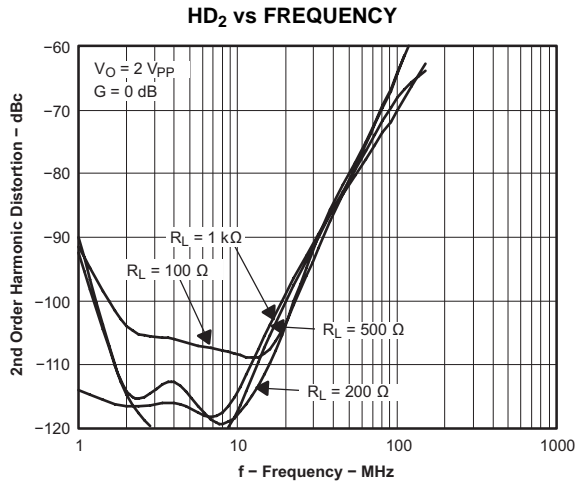

Figure 5.

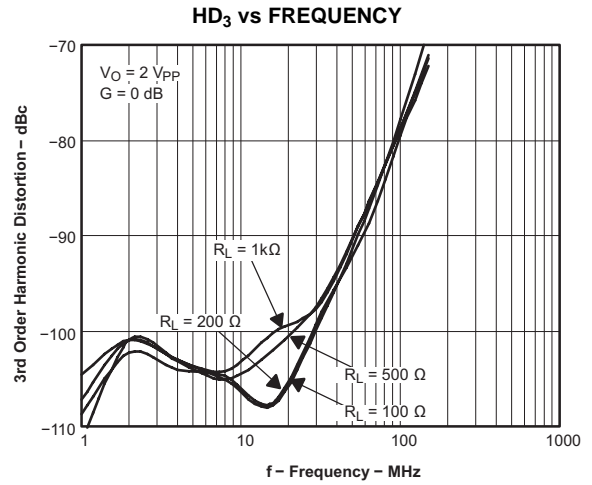

Figure 6.

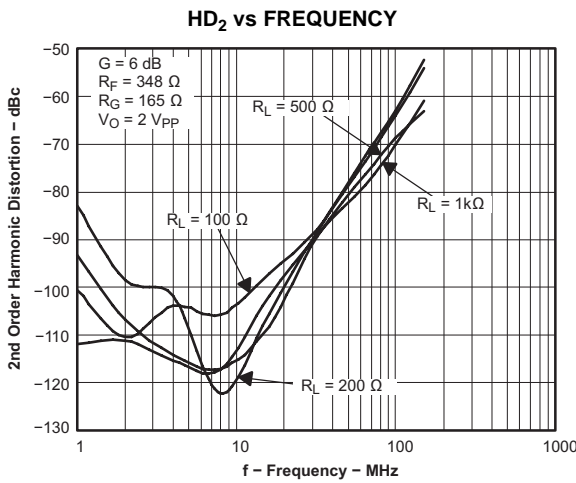

Figure 7.

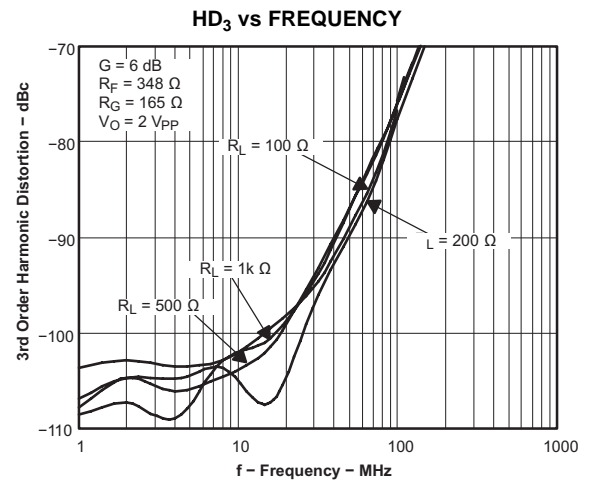

Figure 8.

**TYPICAL CHARACTERISTICS:  $V_{S+} - V_{S-} = 5\text{ V}$  (continued)**

Test conditions unless otherwise noted:  $V_{S+} = 5\text{ V}$ ,  $V_{S-} = 0\text{ V}$ ,  $G = 0\text{ dB}$ ,  $\text{CM} = \text{open}$ ,  $V_O = 2\text{ V}_{PP}$ ,  $R_F = 349\ \Omega$ ,  $R_L = 200\ \Omega$  differential, single-ended input, input referenced to ground, and output referenced to midrail.

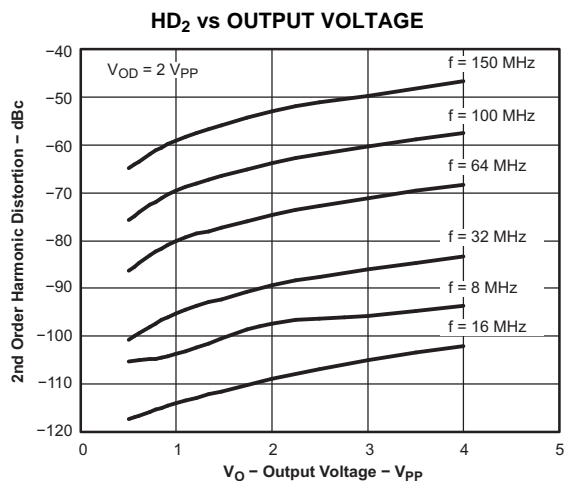

Figure 9.

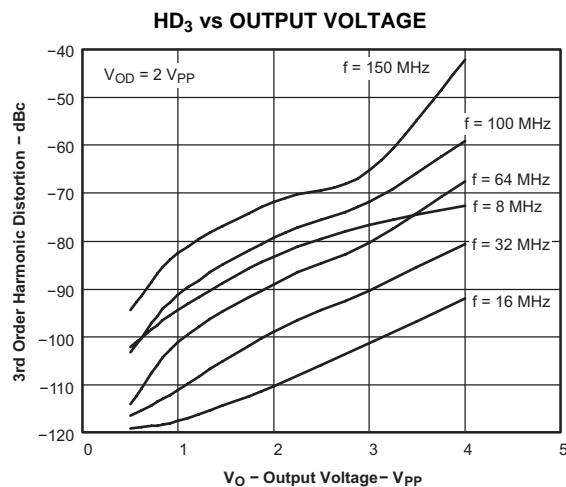

Figure 10.

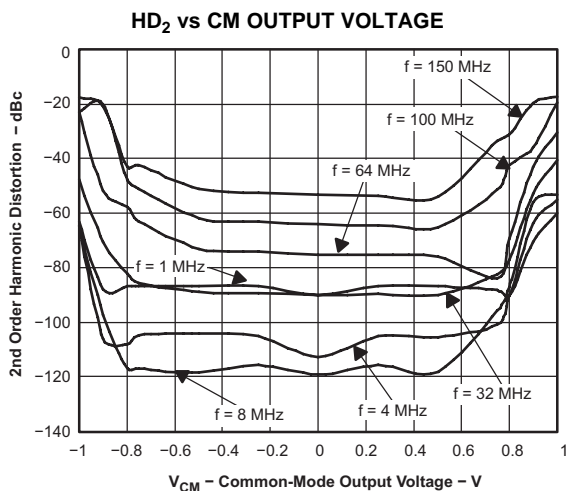

Figure 11.

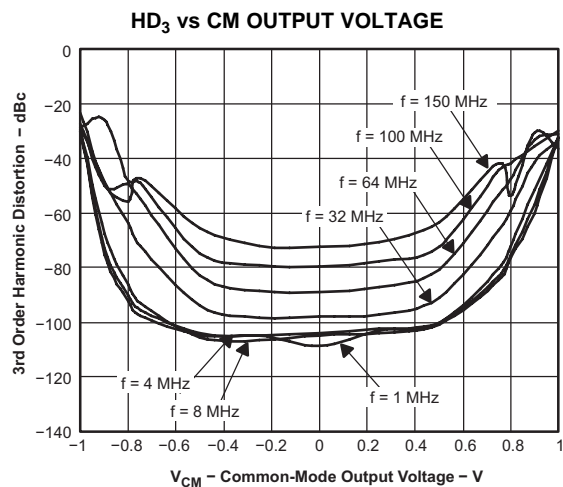
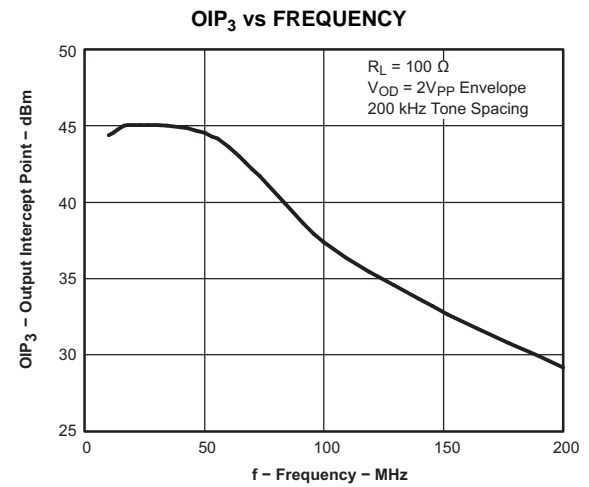
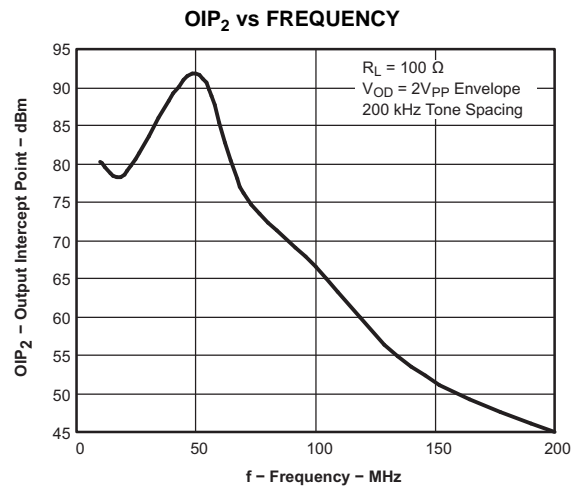
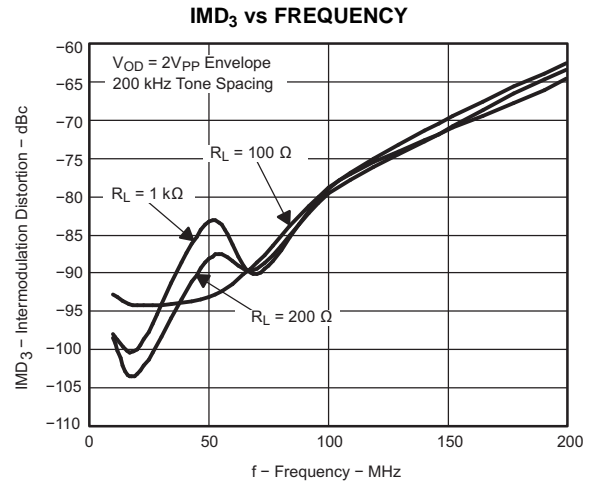
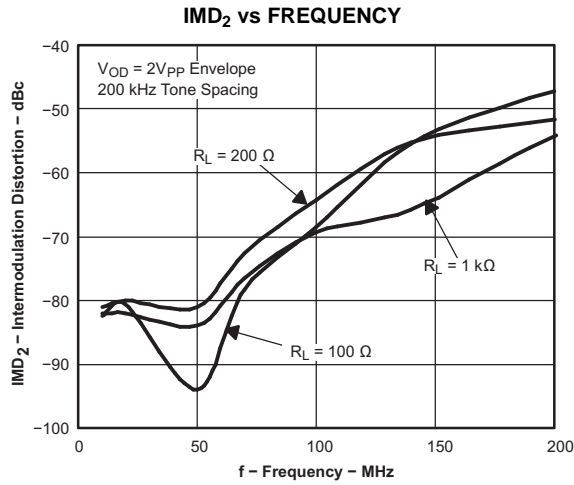

Figure 12.

**TYPICAL CHARACTERISTICS:  $V_{S+} - V_{S-} = 5\text{ V}$  (continued)**

Test conditions unless otherwise noted:  $V_{S+} = 5\text{ V}$ ,  $V_{S-} = 0\text{ V}$ ,  $G = 0\text{ dB}$ ,  $CM = \text{open}$ ,  $V_O = 2\text{ V}_{PP}$ ,  $R_F = 349\ \Omega$ ,  $R_L = 200\ \Omega$  differential, single-ended input, input referenced to ground, and output referenced to midrail.



**TYPICAL CHARACTERISTICS:  $V_{S+} - V_{S-} = 5\text{ V}$  (continued)**

Test conditions unless otherwise noted:  $V_{S+} = 5\text{ V}$ ,  $V_{S-} = 0\text{ V}$ ,  $G = 0\text{ dB}$ ,  $CM = \text{open}$ ,  $V_O = 2\text{ V}_{PP}$ ,  $R_F = 349\ \Omega$ ,  $R_L = 200\ \Omega$  differential, single-ended input, input referenced to ground, and output referenced to midrail.

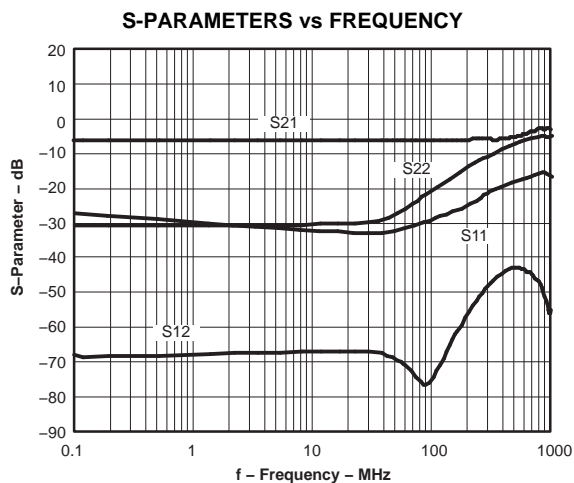

**Figure 17.**

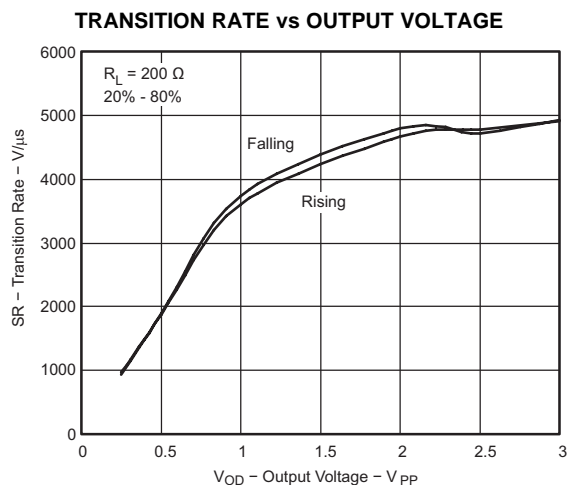

**Figure 18.**

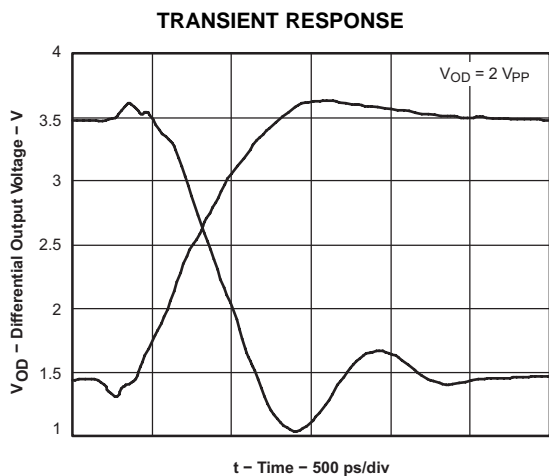

**Figure 19.**

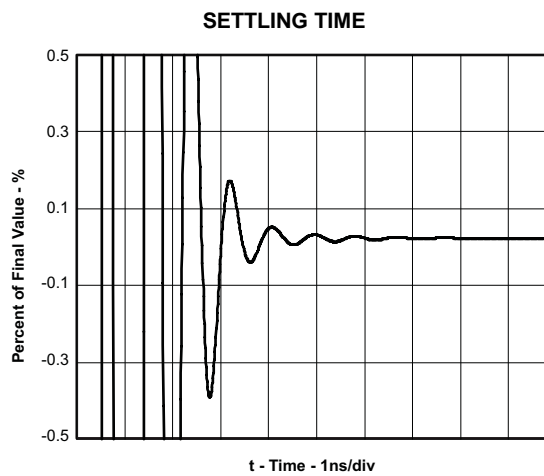

**Figure 20.**

**TYPICAL CHARACTERISTICS:  $V_{S+} - V_{S-} = 5\text{ V}$  (continued)**

Test conditions unless otherwise noted:  $V_{S+} = 5\text{ V}$ ,  $V_{S-} = 0\text{ V}$ ,  $G = 0\text{ dB}$ ,  $\text{CM} = \text{open}$ ,  $V_O = 2\text{ V}_{PP}$ ,  $R_F = 349\ \Omega$ ,  $R_L = 200\ \Omega$  differential, single-ended input, input referenced to ground, and output referenced to midrail.

**REJECTION RATIOS vs FREQUENCY**

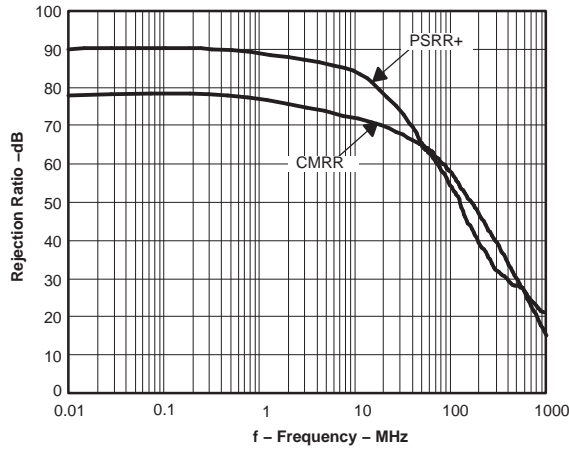

Figure 21.

**OUTPUT IMPEDANCE vs FREQUENCY**

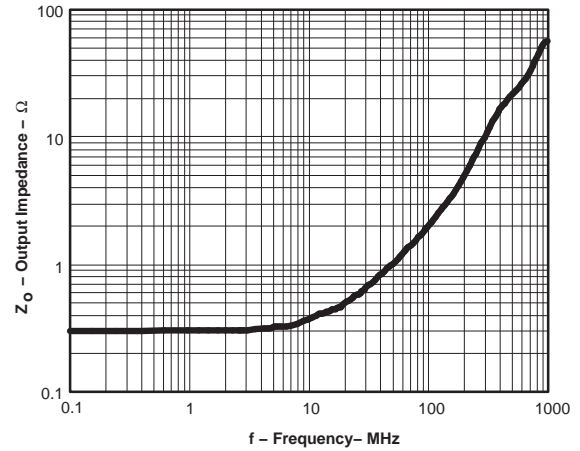

Figure 22.

**OVERDRIVE RECOVERY**

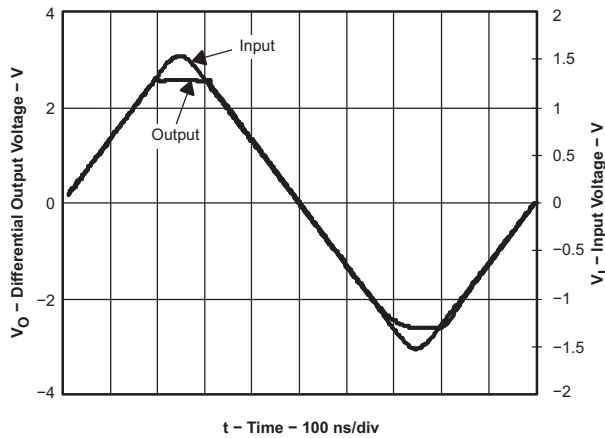

Figure 23.

**DIFFERENTIAL OUTPUT VOLTAGE vs LOAD RESISTANCE**

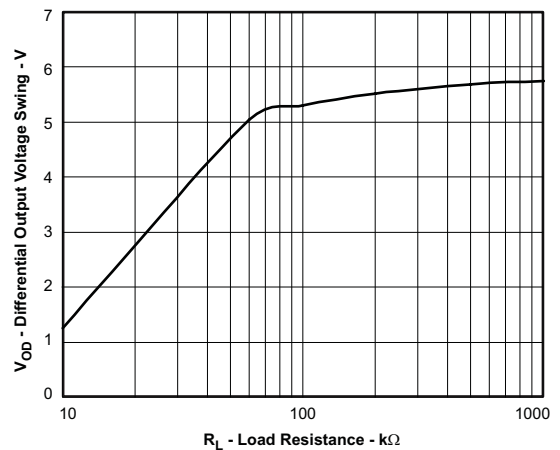

Figure 24.

**TYPICAL CHARACTERISTICS:  $V_{S+} - V_{S-} = 5\text{ V}$  (continued)**

Test conditions unless otherwise noted:  $V_{S+} = 5\text{ V}$ ,  $V_{S-} = 0\text{ V}$ ,  $G = 0\text{ dB}$ ,  $CM = \text{open}$ ,  $V_O = 2\text{ V}_{PP}$ ,  $R_F = 349\ \Omega$ ,  $R_L = 200\ \Omega$  differential, single-ended input, input referenced to ground, and output referenced to midrail.

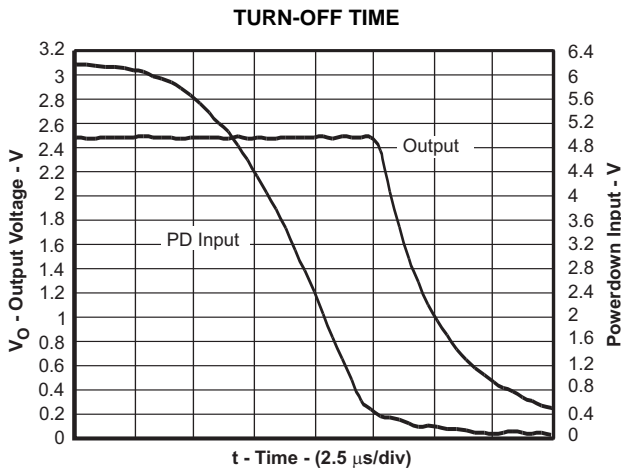

Figure 25.

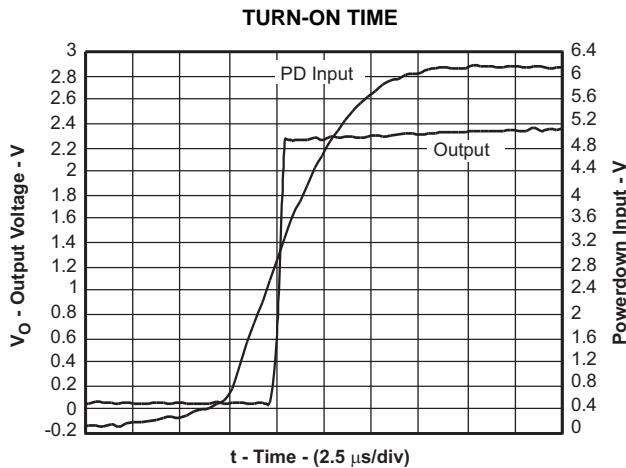

Figure 26.

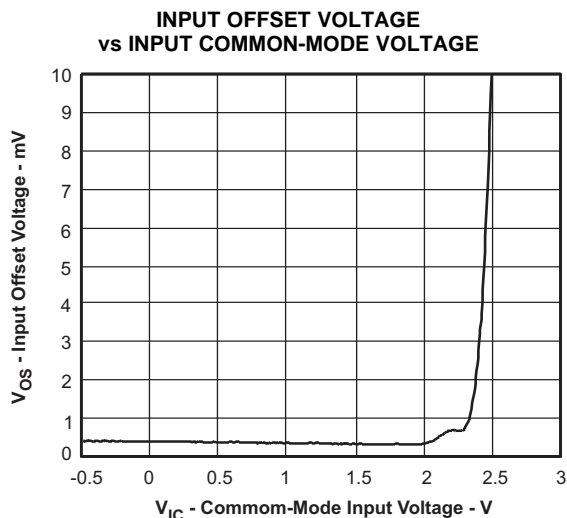

Figure 27.

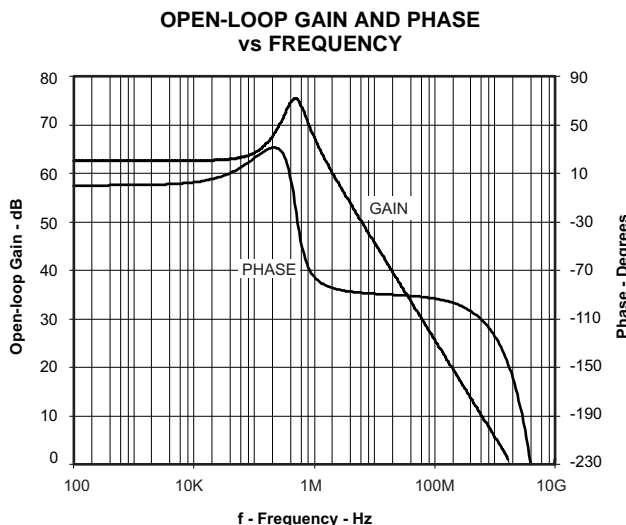

Figure 28.

**TYPICAL CHARACTERISTICS:  $V_{S+} - V_{S-} = 5\text{ V}$  (continued)**

Test conditions unless otherwise noted:  $V_{S+} = 5\text{ V}$ ,  $V_{S-} = 0\text{ V}$ ,  $G = 0\text{ dB}$ ,  $CM = \text{open}$ ,  $V_O = 2\text{ V}_{PP}$ ,  $R_F = 349\ \Omega$ ,  $R_L = 200\ \Omega$  differential, single-ended input, input referenced to ground, and output referenced to midrail.

**INPUT-REFERRED NOISE vs FREQUENCY**

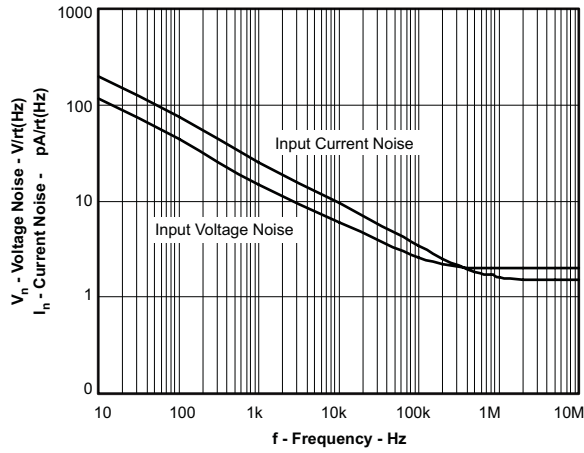

Figure 29.

**NOISE FIGURE vs FREQUENCY**

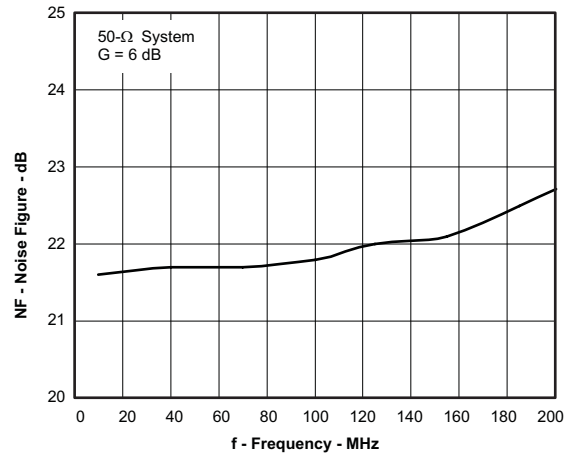

Figure 30.

**QUIESCENT CURRENT vs SUPPLY VOLTAGE**

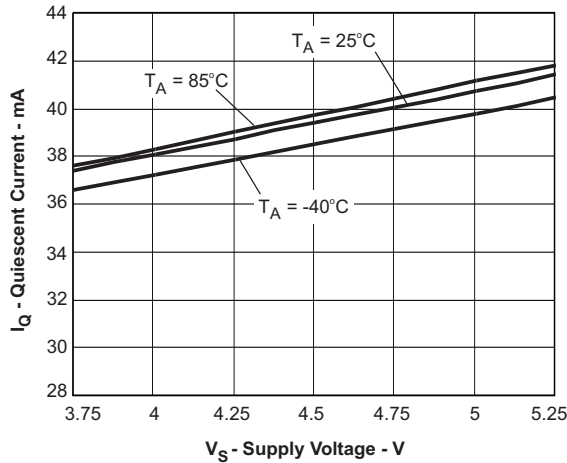

Figure 31.

**OUTPUT BALANCE ERROR vs FREQUENCY**

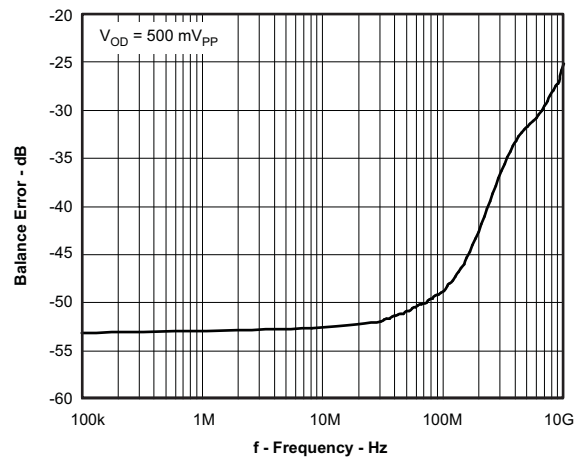

Figure 32.

**TYPICAL CHARACTERISTICS:  $V_{S+} - V_{S-} = 5\text{ V}$  (continued)**

Test conditions unless otherwise noted:  $V_{S+} = 5\text{ V}$ ,  $V_{S-} = 0\text{ V}$ ,  $G = 0\text{ dB}$ ,  $CM = \text{open}$ ,  $V_O = 2\text{ V}_{PP}$ ,  $R_F = 349\ \Omega$ ,  $R_L = 200\ \Omega$  differential, single-ended input, input referenced to ground, and output referenced to midrail.

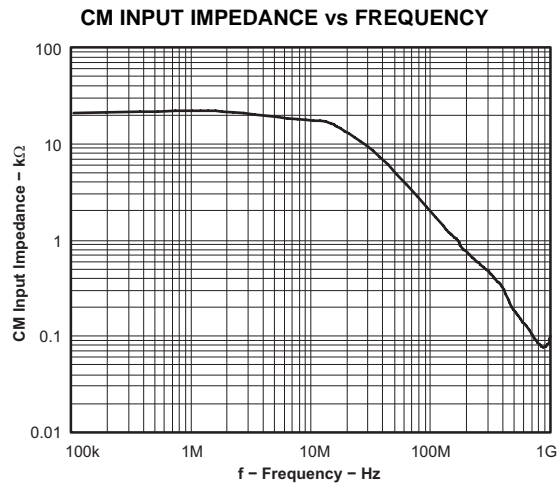

Figure 33.

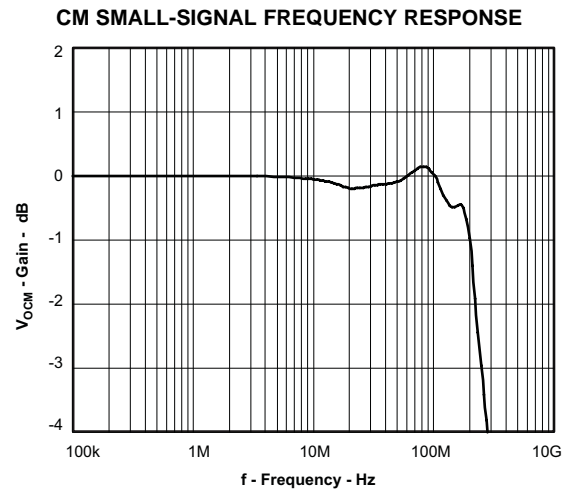

Figure 34.

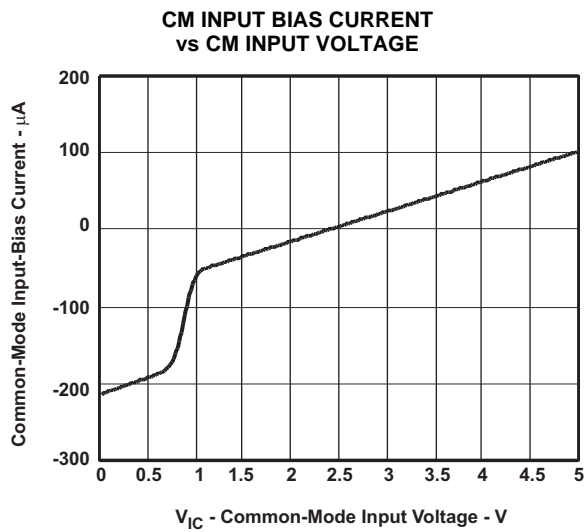

Figure 35.

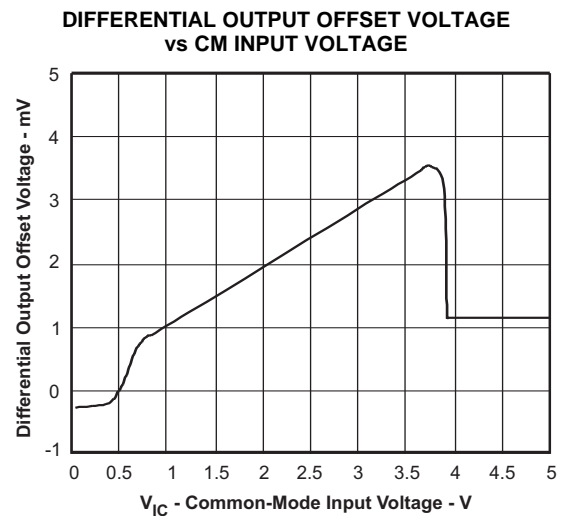

Figure 36.

**TYPICAL CHARACTERISTICS:  $V_{S+} - V_{S-} = 5\text{ V}$  (continued)**

Test conditions unless otherwise noted:  $V_{S+} = 5\text{ V}$ ,  $V_{S-} = 0\text{ V}$ ,  $G = 0\text{ dB}$ ,  $\text{CM} = \text{open}$ ,  $V_O = 2\text{ V}_{PP}$ ,  $R_F = 349\ \Omega$ ,  $R_L = 200\ \Omega$  differential, single-ended input, input referenced to ground, and output referenced to midrail.

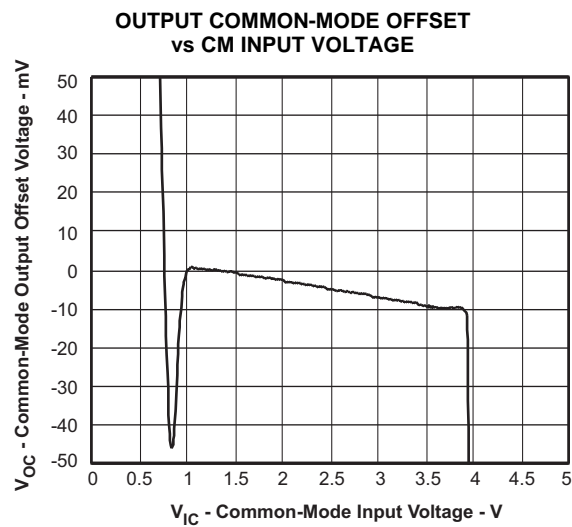

Figure 37.

## TEST CIRCUITS

The THS4511 is tested with the following test circuits built on the evaluation module (EVM). For simplicity, the power-supply decoupling is not shown—see [Layout](#) in the [Application Information](#) section for recommendations. Depending on the test conditions, component values are changed per the following tables, or as otherwise noted. The signal generators used are ac-coupled 50-Ω sources, and a 0.22-μF capacitor and 49.9-Ω resistor to ground are inserted across  $R_{IT}$  on the alternate input to balance the circuit.

**Table 1. Gain Component Values**

GAIN	$R_F$	$R_G$	$R_{IT}$
0 dB	348 Ω	340 Ω	56.2 Ω
6 dB	348 Ω	165 Ω	61.9 Ω

**Note the gain setting includes 50-Ω source impedance. Components are chosen to achieve gain and 50-Ω input termination.**

**Table 2. Load Component Values**

$R_L$	$R_O$	$R_{OT}$	ATTEN.
100 Ω	25 Ω	Open	6 dB
200 Ω	86.6 Ω	69.8 Ω	16.8 dB
499 Ω	237 Ω	56.2 Ω	25.5 dB
1 kΩ	487 Ω	52.3 Ω	31.8 dB

**Note the total load includes 50-Ω termination by the test equipment. Components are chosen to achieve load and 50-Ω line termination through a 1:1 transformer.**

Due to the voltage divider on the output formed by the load component values, the amplifier output is attenuated. The column *Atten* in [Table 2](#) shows the attenuation expected from the resistor divider. When using a transformer at the output as shown in [Figure 39](#), the signal will see slightly more loss, and these numbers will be approximate.

### Frequency Response

The circuit shown in [Figure 38](#) is used to measure the frequency response of the circuit.

A network analyzer is used as the signal source and as the measurement device. The output impedance of the network analyzer is 50 Ω.  $R_{IT}$  and  $R_G$  are chosen to impedance match to 50 Ω, and to maintain the proper gain. To balance the amplifier, a 0.22-μF capacitor and 49.9-Ω resistor to ground are inserted across  $R_{IT}$  on the alternate input.

The output is probed using a high-impedance differential probe across the 100-Ω resistor. The gain is referred to the amplifier output by adding back the 6-dB loss due to the voltage divider on the output.

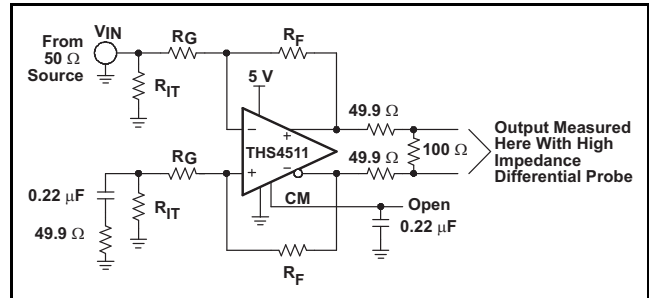

**Figure 38. Frequency Response Test Circuit**

### Distortion and 1-dB Compression

The circuit shown in [Figure 39](#) is used to measure harmonic distortion, intermodulation distortion, and 1-dB compression point of the amplifier.

A signal generator is used as the signal source and the output is measured with a spectrum analyzer. The output impedance of the signal generator is 50 Ω.  $R_{IT}$  and  $R_G$  are chosen to impedance-match to 50 Ω, and to maintain the proper gain. To balance the amplifier, a 0.22-μF capacitor and 49.9-Ω resistor to ground are inserted across  $R_{IT}$  on the alternate input.

A low-pass filter is inserted in series with the input to reduce harmonics generated at the signal source. The level of the fundamental is measured, then a high-pass filter is inserted at the output to reduce the fundamental so that it does not generate distortion in the input of the spectrum analyzer.

The transformer used in the output to convert the signal from differential to single ended is an ADT1-1WT. It limits the frequency response of the circuit so that measurements cannot be made below approximately 1 MHz.

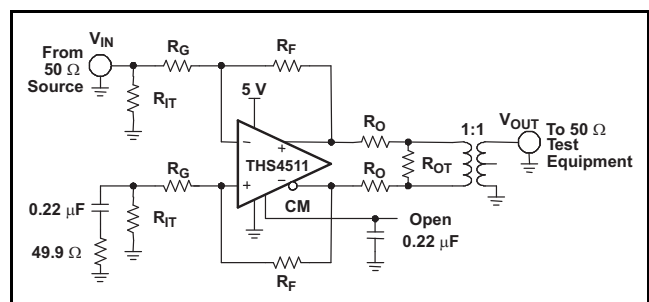

**Figure 39. Distortion Test Circuit**

The 1-dB compression point is measured with a spectrum analyzer with 50-Ω double termination or 100-Ω termination as shown in [Table 2](#). The input power is increased until the output is 1 dB lower than expected. The number reported in the table data is the power delivered to the spectrum analyzer input. Add 3 dB to refer to the amplifier output.

**S-Parameter, Slew Rate, Transient Response, Settling Time, Output Impedance, Overdrive, Output Voltage, and Turn-On/Off Time**

The circuit shown in Figure 40 is used to measure s-parameters, slew rate, transient response, settling time, output impedance, overdrive recovery, output voltage swing, and turn-on/turn-off times of the amplifier. For output impedance, the signal is injected at  $V_{OUT}$  with  $V_{IN}$  left open and the drop across the 49.9-Ω resistor is used to calculate the impedance seen looking into the amplifier output.

Because  $S_{21}$  is measured single-ended at the load with 50-Ω double termination, add 12 dB to refer to the amplifier output as a differential signal.

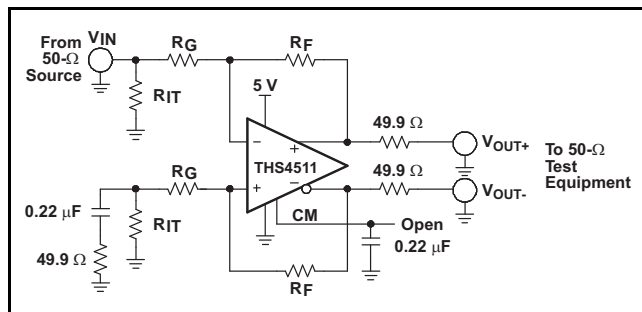

**Figure 40. S-Parameter, SR, Transient Response, Settling Time,  $Z_O$ , Overdrive Recovery,  $V_{OUT}$  Swing, and Turn-On/Off Test Circuit**

**CM Input**

The circuit shown in Figure 41 is used to measure the frequency response and input impedance of the CM input. Frequency response is measured single-ended at  $V_{OUT+}$  or  $V_{OUT-}$  with the input injected at  $V_{IN}$ ,  $R_{CM} = 0 \Omega$ , and  $R_{CMT} = 49.9 \Omega$ . The input impedance is measured with  $R_{CM} = 49.9 \Omega$  with  $R_{CMT} = \text{open}$ , and calculated by measuring the voltage drop across  $R_{CM}$  to determine the input current.

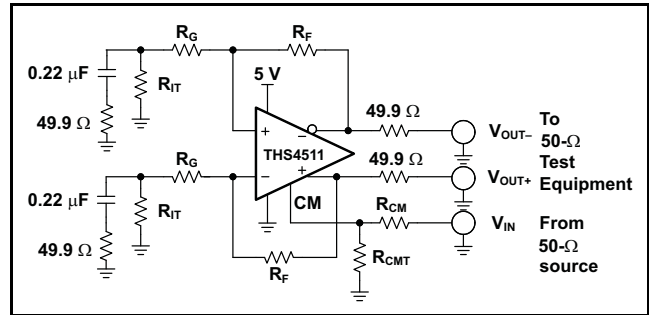

**Figure 41. CM Input Test Circuit**

**CMRR and PSRR**

The circuit shown in Figure 42 is used to measure the CMRR and PSRR of  $V_{S+}$  and  $V_{S-}$ . The input is switched appropriately to match the test being performed.

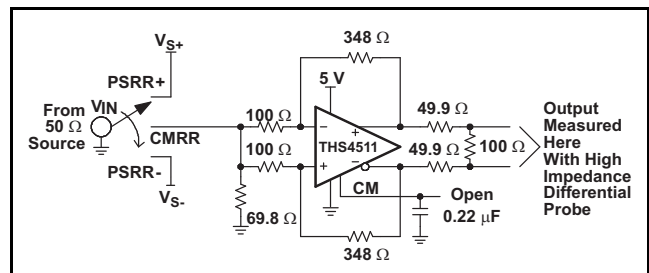

**Figure 42. CMRR and PSRR Test Circuit**

## APPLICATION INFORMATION

### APPLICATIONS

The following circuits show application information for the THS4511. For simplicity, power-supply decoupling capacitors are not shown in these diagrams. For more detail on the use and operation of fully-differential operational amplifiers refer to application report *Fully-Differential Amplifiers* (SLOA054).

#### Differential Input to Differential Output Amplifier

The THS4511 is a fully-differential operational amplifier, and can be used to amplify differential input signals to differential output signals. A basic block diagram of the circuit is shown in Figure 43 (CM input not shown). The gain of the circuit is set by  $R_F$  divided by  $R_G$ .

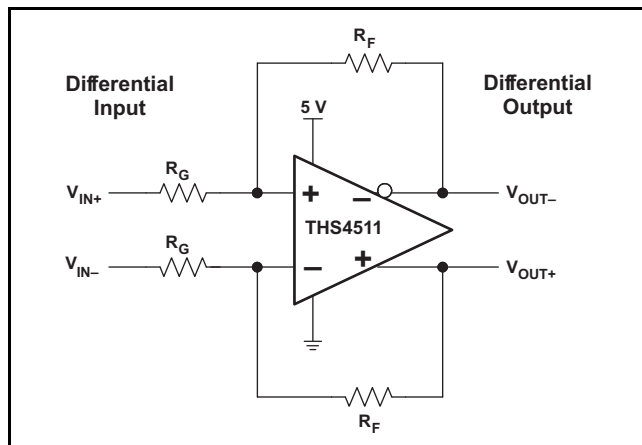

Figure 43. Differential Input to Differential Output Amplifier

Depending on the source and load, input and output termination can be accomplished by adding  $R_{IT}$  and  $R_O$ .

#### Single-Ended Input to Differential Output Amplifier

The THS4511 can be used to amplify and convert single-ended input signals to differential output signals. A basic block diagram of the circuit is shown in Figure 44 (CM input not shown). The gain of the circuit is again set by  $R_F$  divided by  $R_G$ .

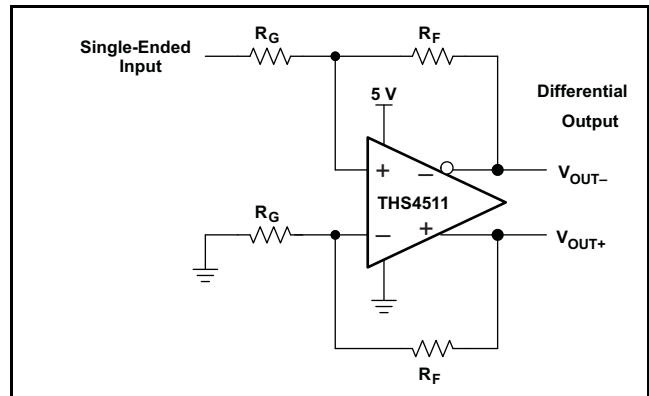

Figure 44. Single-Ended Input to Differential Output Amplifier

#### Input Common-Mode Voltage Range

The input common-mode voltage of a fully-differential operational amplifier is the voltage at the (+) and (-) input pins of the operational amplifier.

It is important to not violate the input common-mode voltage range ( $V_{ICR}$ ) of the operational amplifier. Assuming the operational amplifier is in linear operation the voltage across the input pins is only a few millivolts at most. So finding the voltage at one input pin determines the input common-mode voltage of the operational amplifier.

Treating the negative input as a summing node, the voltage is given by Equation 1:

$$V_{IC} = \left( V_{OUT+} \times \frac{R_G}{R_G + R_F} \right) + \left( V_{IN-} \times \frac{R_F}{R_G + R_F} \right) \quad (1)$$

To determine the  $V_{ICR}$  of the operational amplifier, the voltage at the negative input is evaluated at the extremes of  $V_{OUT+}$ .

As the gain of the operational amplifier increases, the input common-mode voltage becomes closer and closer to the input common-mode voltage of the source.

### Setting the Output Common-Mode Voltage

The output common-mode voltage is set by the voltage at the CM pin(s). The internal common-mode control circuit maintains the output common-mode voltage within 5-mV offset (typical) from the set voltage, when set within 0.5 V of midsupply. If left unconnected, the common-mode set point is set to midsupply by internal circuitry, which may be overdriven from an external source. Figure 45 is representative of the CM input. The internal CM circuit has about 700 MHz of –3-dB bandwidth, which is required for best performance, but it is intended to be a dc-bias input pin. Bypass capacitors are recommended on this pin to reduce noise at the output. The external current required to overdrive the internal resistor divider is given by Equation 2:

$$I_{EXT} = \frac{2V_{CM} - (V_{S+} - V_{S-})}{50\text{ k}\Omega} \tag{2}$$

where  $V_{CM}$  is the voltage applied to the CM pin, and  $V_{S+}$  ranges from 3.75 V to 5 V, and  $V_{S-}$  is 0 V (ground).

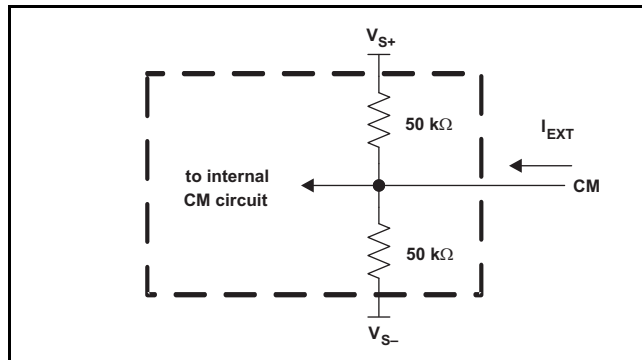

Figure 45. CM Input Circuit

### Device Operation with Single Power Supplies Less than 5 V

The THS4511 is optimized to work in systems using 5-V single supplies, and the characterization data presented in this data sheet were taken with 5-V single-supply inputs. For ac-coupled systems or dc-coupled systems operating with supplies less than 5 V and greater than 3.75 V, the amplifier input common-mode range is maximized by adding pull-down resistors at the device inputs. The pull-down resistors provide additional loading at the input, and lower the common-mode voltage that is fed back into the device input through resistor  $R_F$ . Figure 46 shows the circuit configuration for this mode of operation where  $R_{PD}$  is added to the dc-coupled circuit to avoid violating the  $V_{ICR}$  of the

operational amplifier. Note  $R_S$  and  $R_{IT}$  are added to the alternate input from the signal input to balance the amplifier. One resistor that is equal to the combined value  $R_I = R_G + R_S \parallel R_{IT}$  can be placed at the alternate input.

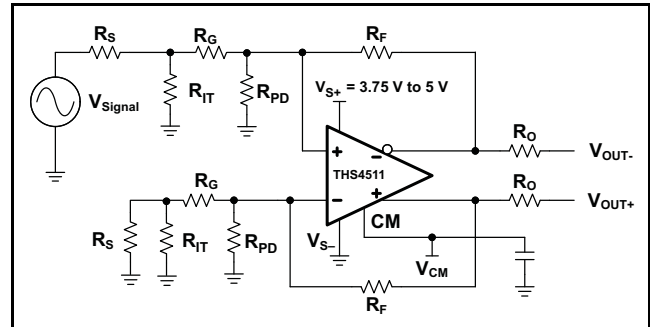

Figure 46. THS4511 DC-Coupled Single-Source Supply Range From 3.75 V to 5 V With  $R_{PD}$  Used To Set  $V_{IC}$

Note that in Figure 46, the source is referenced to ground, as is the input termination resistor  $R_{IT}$ . The proper value of resistance to add can be calculated from Equation 3:

$$R_{PD} = \frac{1}{\frac{1}{R_F} \left[ \frac{1.6}{\frac{V_{S+}}{2} - 1.6} \right] - \frac{1}{R_I}} \tag{3}$$

where  $R_I = R_G + R_S \parallel R_{IT}$ .

$V_{S+}$  is the power-supply voltage,  $R_F$  is the feedback resistance,  $R_G$  is the gain-setting resistance,  $R_S$  is the signal source resistance, and  $R_{IT}$  is the termination resistance.

Table 3 is a modification of Table 1 to add the proper values with  $R_{PD}$  assuming  $V_{S+} = 3.75$  V, a dc-coupled 50-Ω source impedance, and setting the output common-mode voltage to midsupply.

Table 3.  $R_{PD}$  Values for Various Gains,  $V_{S+} = 3.75$  V, DC-coupled Signal Source

GAIN	$R_F$	$R_G$	$R_{IT}$	$R_{PD}$
0 dB	348 Ω	340 Ω	56.2 Ω	422 Ω
6 dB	348 Ω	169 Ω	64.9 Ω	86.6 Ω

If the signal originates from an ac-coupled 50-Ω source (see Figure 47), the equivalent dc-source resistance is an open circuit and  $R_I = R_G + R_{IT}$ . Table 4 is a modification of Table 1 to add the proper values with  $R_{PD}$  assuming  $V_{S+} = 3.75$  V, an ac-coupled 50-Ω source impedance, and setting the output common-mode voltage to midsupply.

**Table 4.  $R_{PD}$  Values for Various Gains,  $V_{S+} = 3.75$  V, AC-Coupled Signal Source**

GAIN	$R_F$	$R_G$	$R_{IT}$	$R_{PD}$
0 dB	348 Ω	340 Ω	56.2 Ω	390 Ω
6 dB	348 Ω	169 Ω	64.9 Ω	80.6 Ω

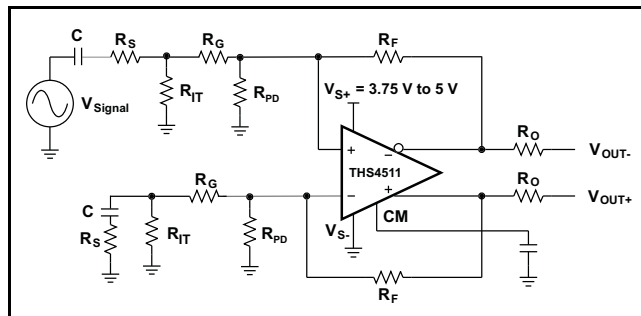

**Figure 47. THS4511 AC-Coupled Single-Source Supply Range From 3.75 V to 5 V With  $R_{PD}$  Used To Set  $V_{IC}$**

**Video Buffer**

Figure 48 shows a possible application of the THS4508 as a dc-coupled video buffer with a gain of 2. Figure 49 shows a plot of the Y' signal originating from an HDTV 720p video system. The input signal includes a 3-level sync (minimum level at -0.3 V) and the portion of a video signal with maximum amplitude of 0.7 V. Although the buffer draws its power from a 5-V single-ended power supply, internal level shifters allow the buffer to support input signals which are as much as -0.3 V below ground. This allows maximum design flexibility while maintaining a minimum parts count. Figure 50 shows the differential output of the buffer. Note that the dc-coupled amplifier can introduce a dc offset on a signal applied at its input.

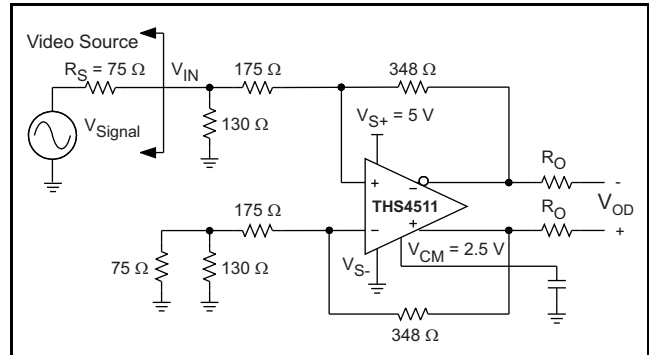

**Figure 48. Single-Supply Video Buffer, Gain = 2**

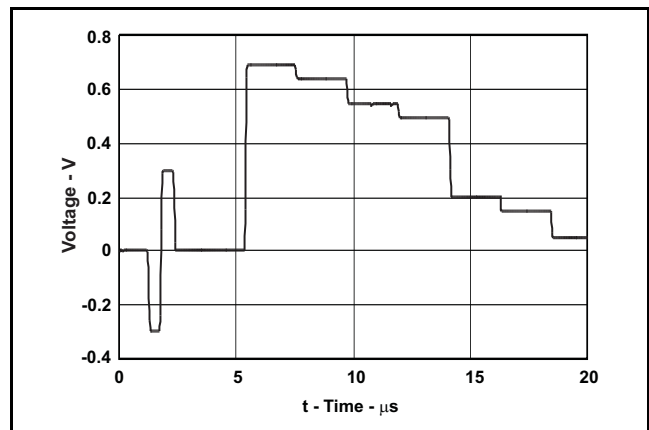

**Figure 49. Y' Signal with 3-Level Sync and Video Signal**

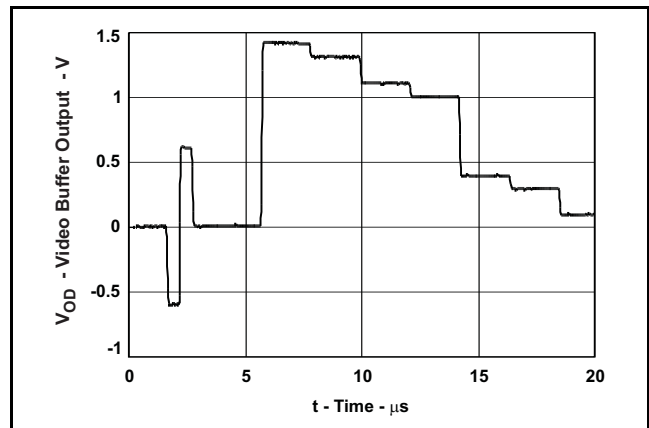

**Figure 50. Video Buffer Differential Output Signal**

**THS4511 and ADS5500 Combined Performance**

The THS4511 is designed to be a high-performance drive amplifier for high-performance data converters like the ADS5500 14-bit 125-MSPS ADC. Figure 51 shows a circuit combining the two devices. The THS4511 amplifier circuit provides 0 dB of gain, and converts the single-ended input signal to a differential output signal. The default common-mode output of the THS4511 (2.5 V) is not compatible with the required common-mode input of the ADS5500 (1.55 V), so dc-blocking capacitors are added (0.22  $\mu$ F). Note that a biasing circuit (not shown in Figure 51) is needed to provide the required common-mode, dc-input for the ADS5500. The 100- $\Omega$  resistors and 2.7-pF capacitor between the THS4511 outputs and ADS5500 inputs along with the input capacitance of the ADS5500 limit the bandwidth of the signal to 115 MHz ( $-3$  dB). For testing, a signal generator is used for the signal source. The generator is an ac-coupled 50- $\Omega$  source. A band-pass filter is inserted in series with the input to reduce harmonics and noise from the signal source. Input termination is accomplished via the 69.8- $\Omega$  resistor and 0.22- $\mu$ F capacitor to ground in conjunction with the input impedance of the amplifier circuit. A 0.22- $\mu$ F capacitor and 49.9- $\Omega$  resistor is inserted to ground across the 69.8- $\Omega$  resistor and 0.22- $\mu$ F capacitor on the alternate input to balance the circuit. Gain is a function of the source impedance, termination, and 348- $\Omega$  feedback resistor. See Table 1 for component values to set proper 50- $\Omega$  termination for other common gains.

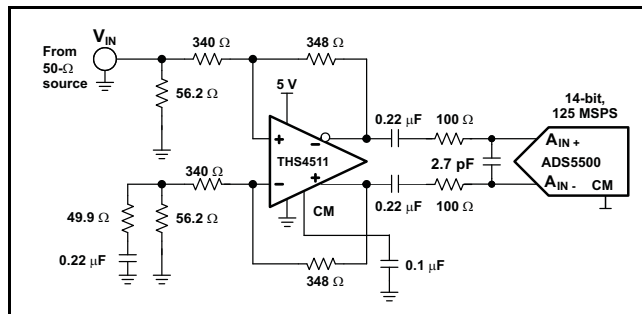

**Figure 51. THS4511 and ADS5500 Circuit**

**THS4511 and ADS5424 Combined Performance**

Figure 52 shows the THS4511 driving the ADS5424 ADC.

As before, the THS4511 amplifier provides 0 dB of gain, converts the single-ended input to differential, and sets the proper input common-mode voltage to the ADS5424. Input termination and circuit testing is the same as described above for the THS4511 and ADS5500 circuit.

The 225- $\Omega$  resistors and 2.7-pF capacitor between the THS4511 outputs and ADS5424 inputs (along with the input capacitance of the ADC) limit the bandwidth of the signal to about 100 MHz ( $-3$  dB).

When the THS4511 is operated from a single power supply with  $V_{S+} = 5$  V and  $V_{S-} =$  ground, the 2.5-V output common-mode voltage is compatible with the recommended value of the ADS5424 input common-mode voltage (2.4 V).

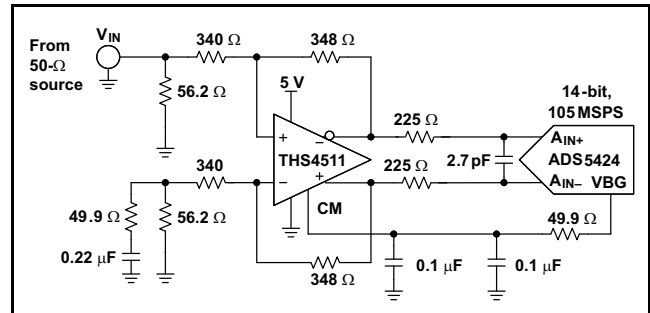

**Figure 52. THS4511 and ADS5424 Circuit**

## Layout Recommendations

It is recommended to follow the layout of the external components near the amplifier, ground plane construction, and power routing of the EVM as closely as possible. General guidelines are:

1. Signal routing should be direct and as short as possible into and out of the operational amplifier circuit.
2. The feedback path should be short and direct; avoid vias.
3. Ground or power planes should be removed from directly under the amplifier input and output pins.
4. An output resistor is recommended on each output, as near to the output pin as possible.
5. Two 10- $\mu$ F and two 0.1- $\mu$ F power-supply decoupling capacitors should be placed as near to the power-supply pins as possible.
6. Two 0.1- $\mu$ F capacitors should be placed between the CM input pins and ground. This configuration limits noise coupled into the pins. One each should be placed to ground near pin 4 and pin 9.
7. It is recommended to split the ground plane on layer 2 (L2) as shown below and to use a solid ground on layer 3 (L3). A single-point connection should be used between each split section on L2 and L3.
8. A single-point connection to ground on L2 is recommended for the input termination resistors R1 and R2. This configuration should be applied to the input gain resistors if termination is not used.
9. The recommended printed circuit board (PCB) footprint for the THS4511 is shown in [Figure 54](#).

## PowerPAD™ DESIGN CONSIDERATIONS

The THS4511 is available in a thermally-enhanced PowerPAD family of packages. These packages are constructed using a downset leadframe on which the die is mounted (see [Figure 53a](#) and [Figure 53b](#)). This arrangement results in the lead frame being exposed

as a thermal pad on the underside of the package (see [Figure 53c](#)). Because this thermal pad has direct thermal contact with the die, excellent thermal performance can be achieved by providing a good thermal path away from the thermal pad.

Note that the THS4511 has no electrical connection between the PowerPAD and circuitry on the die. Connecting the PowerPAD to any potential voltage between  $V_{S+}$  and  $V_{S-}$  is acceptable. It is most important that it be connected for maximum heat dissipation.

The PowerPAD package allows both assembly and thermal management in one manufacturing operation.

During the surface-mount solder operation (when the leads are being soldered), the thermal pad can also be soldered to a copper area underneath the package. Through the use of thermal paths within this copper area, heat can be conducted away from the package into either a ground plane or other heat dissipating device.

The PowerPAD package represents a breakthrough in combining the small area and ease of assembly of surface-mount with the heretofore awkward mechanical methods of heatsinking.

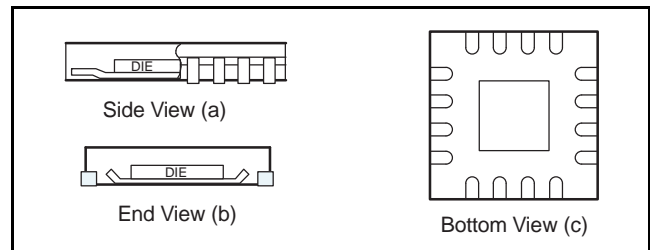

**Figure 53. Views of Thermally-Enhanced Package**

## PowerPAD PCB LAYOUT CONSIDERATIONS

Although there are many ways to properly heatsink the PowerPAD package, the following steps illustrate the recommended approach.

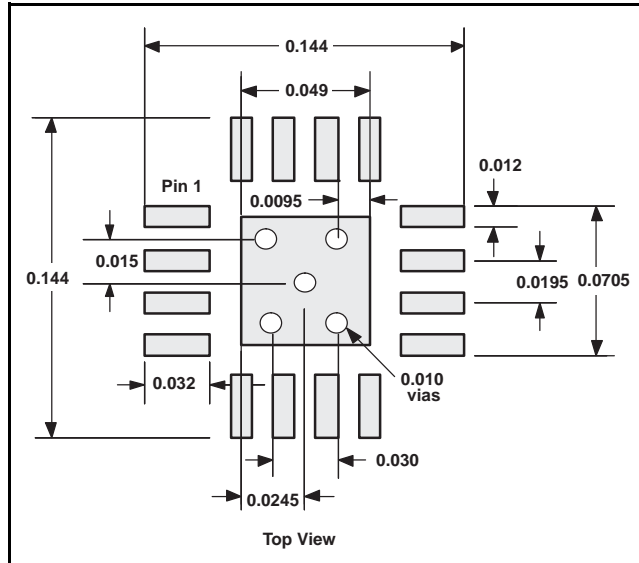

**Figure 54. PowerPAD PCB Etch and Via Pattern**

1. Prepare the PCB with a top side etch pattern as shown in [Figure 54](#). There should be etch for the leads as well as etch for the thermal pad.
2. Place five holes in the area of the thermal pad. The holes should be 13 mils (0.013 in, 0.33 mm) in diameter. Keep them small so that solder wicking through the holes is not a problem during reflow.
3. Additional vias may be placed anywhere along the thermal plane outside of the thermal pad area. They help dissipate the heat generated by the IC. These additional vias may be larger than the 13-mil diameter vias directly under the thermal pad. They can be larger because they are not in the thermal pad area to be soldered, so that wicking is not a problem.
4. Connect all holes to the internal ground plane.
5. When connecting these holes to the ground plane, **do not** use the typical web or spoke via connection methodology. Web connections have a high thermal resistance connection that is

useful for slowing the heat transfer during soldering operations. This resistance makes the soldering of vias that have plane connections easier. In this application, however, low thermal resistance is desired for the most efficient heat transfer. Therefore, the holes under the IC PowerPAD package should make the connection to the internal ground plane, with a complete connection around the entire circumference of the plated-through hole.

6. The top-side solder mask should leave the terminals of the package and the thermal pad area with its five holes exposed. The bottom-side solder mask should cover the five holes of the thermal pad area. This configuration prevents solder from being pulled away from the thermal pad area during the reflow process.
7. Apply solder paste to the exposed thermal pad area and all of the IC terminals.
8. With these preparatory steps in place, the IC is simply placed in position and run through the solder reflow operation as any standard surface-mount component. This process results in a part that is properly installed.

The next consideration is the package constraints. The two sources of heat within an amplifier are quiescent power and output power. The designer should never forget about the quiescent heat generated within the device, especially multi-amplifier devices. Because these devices have linear output stages (Class AB), most of the heat dissipation is at low output voltages with high output currents.

The other key factor when dealing with power dissipation is how the devices are mounted on the PCB. The PowerPAD devices are extremely useful for heat dissipation. But the device should always be soldered to a copper plane to fully use the heat dissipation properties of the PowerPAD. The SOIC package, on the other hand, is highly dependent on how it is mounted on the PCB. As more trace and copper area is placed around the device,  $\theta_{JA}$  decreases and the heat dissipation capability increases. For a single package, the sum of the RMS output currents and voltages should be used to choose the proper package.



**Table 5. THS4511RGT EVM Bill of Materials**

ITEM	DESCRIPTION	SMD SIZE	REFERENCE DESIGNATOR	PCB QTY	MANUFACTURER PART NUMBER <sup>(1)</sup>
1	CAP, 10.0 $\mu$ F, Ceramic, X5R, 6.3V	0805	C3, C5	2	(AVX) 08056D106KAT2A
2	CAP, 0.1 $\mu$ F, Ceramic, X5R, 10V	0402	C11-C14	4	(AVX) 0402ZD104KAT2A
3	CAP, 0.22 $\mu$ F, Ceramic, X5R, 6.3V	0402	C15	1	(AVX) 04026D224KAT2A
4	OPEN	0402	C1, C2, C7-C10	6	
5	OPEN	0402	R9, R10	2	
6	Resistor, 49.9 $\Omega$ , 1/16W, 1%	0402	R12	1	(KOA) RK73H1ETTP49R9F
7	Resistor, 56.2 $\Omega$ , 1/16W, 1%	0402	R1, R2		(KOA) RK73H1ETTP56R2F
8	Resistor, 69.8 $\Omega$ , 1/16W, 1%	0402	R11	3	(KOA) RK73H1ETTP69R8F
9	Resistor, 86.6 $\Omega$ , 1/16W, 1%	0402	R7, R8	2	(KOA) RK73H1ETTP86R6F
10	Resistor, 340 $\Omega$ , 1/16W, 1%	0402	R3, R4	2	(KOA) RK73H1ETTP3400F
11	Resistor, 348 $\Omega$ , 1/16W, 1%	0402	R5, R6	2	(KOA) RK73H1ETTP3480F
12	Resistor, 0 $\Omega$ , 5%	0805	C4, C6	2	(KOA) RK73Z2ATTD
13	Transformer, RF		T1	1	(MINI-CIRCUITS) ADT1-1WT
14	Jack, banana receptance, 0.25" diameter hole		J5, J6	2	(HH SMITH) 101
15	OPEN		J1, J7, J8	3	
16	Connector, edge, SMA PCB Jack		J2, J3	2	(JOHNSON) 142-0701-801
17	Test point, Red		TP1, TP2, TP3	3	(KEYSTONE) 5000
18	IC, THS4511		U1	1	(TI) THS4511RGT
19	Standoff, 4-40 HEX, 0.625" length			4	(KEYSTONE) 1808
20	SCREW, PHILLIPS, 4-40, 0.250"			4	SHR-0440-016-SN
21	Printed circuit board			1	(TI) EDGE# 6475513

(1) The manufacturer's part numbers were used for test purposes only.

## EVM WARNINGS AND RESTRICTIONS

It is important to operate this EVM within the input and output voltage ranges as specified in the table provided below.

<b>INPUT RANGE, <math>V_{S+}</math> TO <math>V_{S-}</math></b>	<b>3.0 V TO 6.0 V</b>
Input Range, $V_I$	3.0 V to 6.0 V NOT TO EXCEED $V_{S+}$ or $V_{S-}$
Output Range, $V_O$	3.0 V to 6.0 V NOT TO EXCEED $V_{S+}$ or $V_{S-}$

Exceeding the specified input range may cause unexpected operation and/or irreversible damage to the EVM. If there are questions concerning the input range, please contact a TI field representative prior to connecting the input power.

Applying loads outside of the specified output range may result in unintended operation and/or possible permanent damage to the EVM. Please consult the product data sheet or EVM user's guide (if user's guide is available) prior to connecting any load to the EVM output. If there is uncertainty as to the load specification, please contact a TI field representative.

During normal operation, some circuit components may have case temperatures greater than +30°C. The EVM is designed to operate properly with certain components above +50°C as long as the input and output ranges are maintained. These components include but are not limited to linear regulators, switching transistors, pass transistors, and current sense resistors. These types of devices can be identified using the EVM schematic located in the material provided. When placing measurement probes near these devices during operation, please be aware that these devices may be very warm to the touch.

Mailing Address: Texas Instruments Post Office Box 655303 Dallas, Texas 75265

## REVISION HISTORY

NOTE: Page numbers for previous revisions may differ from page numbers in the current version.

<b>Changes from Revision D (May 2007) to Revision E</b>	<b>Page</b>
• Updated document format to match current standards .....	1
• Deleted title and conditions of Typical Conditions table of graphs .....	6
• Added title and conditions to Typical Characteristics plots .....	7
• Changed item 9 in the <i>Layout Recommendations</i> section .....	23
• Added <i>PowerPAD Design Considerations</i> section .....	23
• Added <i>PowerPAD PCB Layout Considerations</i> section .....	24
• Moved <a href="#">Figure 54</a> and associated paragraph to <i>PowerPAD PCB Layout Considerations</i> section .....	24

---

**PACKAGING INFORMATION**

Orderable Device	Status (1)	Package Type	Package Drawing	Pins	Package Qty	Eco Plan (2)	Lead/Ball Finish (6)	MSL Peak Temp (3)	Op Temp (°C)	Device Marking (4/5)	Samples
THS4511RGTT	ACTIVE	VQFN	RGT	16	250	Green (RoHS & no Sb/Br)	CU NIPDAU	Level-2-260C-1 YEAR	-40 to 85	4511	<a href="#">Samples</a>

(1) The marketing status values are defined as follows:

**ACTIVE:** Product device recommended for new designs.

**LIFEBUY:** TI has announced that the device will be discontinued, and a lifetime-buy period is in effect.

**NRND:** Not recommended for new designs. Device is in production to support existing customers, but TI does not recommend using this part in a new design.

**PREVIEW:** Device has been announced but is not in production. Samples may or may not be available.

**OBSOLETE:** TI has discontinued the production of the device.

(2) **RoHS:** TI defines "RoHS" to mean semiconductor products that are compliant with the current EU RoHS requirements for all 10 RoHS substances, including the requirement that RoHS substance do not exceed 0.1% by weight in homogeneous materials. Where designed to be soldered at high temperatures, "RoHS" products are suitable for use in specified lead-free processes. TI may reference these types of products as "Pb-Free".

**RoHS Exempt:** TI defines "RoHS Exempt" to mean products that contain lead but are compliant with EU RoHS pursuant to a specific EU RoHS exemption.

**Green:** TI defines "Green" to mean the content of Chlorine (Cl) and Bromine (Br) based flame retardants meet JS709B low halogen requirements of <=1000ppm threshold. Antimony trioxide based flame retardants must also meet the <=1000ppm threshold requirement.

(3) MSL, Peak Temp. - The Moisture Sensitivity Level rating according to the JEDEC industry standard classifications, and peak solder temperature.

(4) There may be additional marking, which relates to the logo, the lot trace code information, or the environmental category on the device.

(5) Multiple Device Markings will be inside parentheses. Only one Device Marking contained in parentheses and separated by a "~" will appear on a device. If a line is indented then it is a continuation of the previous line and the two combined represent the entire Device Marking for that device.

(6) Lead/Ball Finish - Orderable Devices may have multiple material finish options. Finish options are separated by a vertical ruled line. Lead/Ball Finish values may wrap to two lines if the finish value exceeds the maximum column width.

**Important Information and Disclaimer:**The information provided on this page represents TI's knowledge and belief as of the date that it is provided. TI bases its knowledge and belief on information provided by third parties, and makes no representation or warranty as to the accuracy of such information. Efforts are underway to better integrate information from third parties. TI has taken and continues to take reasonable steps to provide representative and accurate information but may not have conducted destructive testing or chemical analysis on incoming materials and chemicals. TI and TI suppliers consider certain information to be proprietary, and thus CAS numbers and other limited information may not be available for release.

In no event shall TI's liability arising out of such information exceed the total purchase price of the TI part(s) at issue in this document sold by TI to Customer on an annual basis.

**OTHER QUALIFIED VERSIONS OF THS4511 :**

- Space: [THS4511-SP](#)

NOTE: Qualified Version Definitions:

- Space - Radiation tolerant, ceramic packaging and qualified for use in Space-based application

## TAPE AND REEL INFORMATION



### QUADRANT ASSIGNMENTS FOR PIN 1 ORIENTATION IN TAPE



\*All dimensions are nominal

Device	Package Type	Package Drawing	Pins	SPQ	Reel Diameter (mm)	Reel Width W1 (mm)	A0 (mm)	B0 (mm)	K0 (mm)	P1 (mm)	W (mm)	Pin1 Quadrant
THS4511RGTT	VQFN	RGT	16	250	180.0	12.4	3.3	3.3	1.1	8.0	12.0	Q2

**TAPE AND REEL BOX DIMENSIONS**



\*All dimensions are nominal

Device	Package Type	Package Drawing	Pins	SPQ	Length (mm)	Width (mm)	Height (mm)
THS4511RGTT	VQFN	RGT	16	250	210.0	185.0	35.0

**RGT 16**

**GENERIC PACKAGE VIEW**

**VQFN - 1 mm max height**

PLASTIC QUAD FLATPACK - NO LEAD

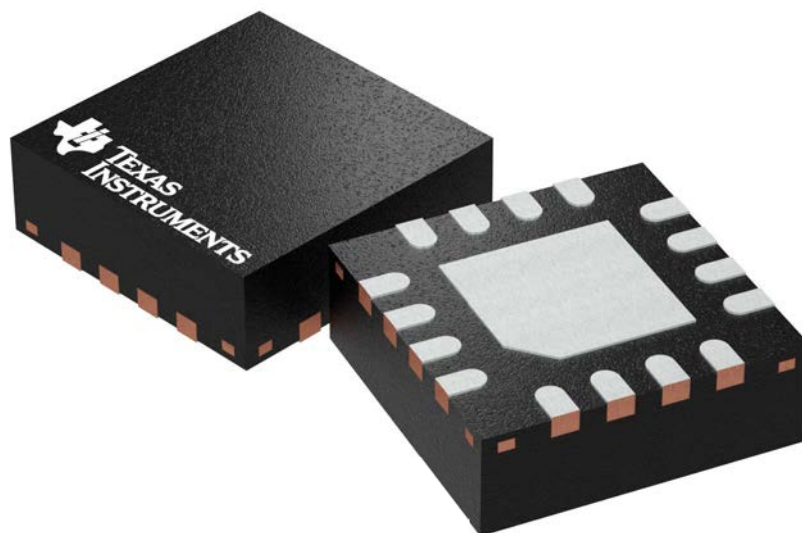

Images above are just a representation of the package family, actual package may vary.  
Refer to the product data sheet for package details.

4203495/1





# EXAMPLE STENCIL DESIGN

RGT0016A

VQFN - 1 mm max height

PLASTIC QUAD FLATPACK - NO LEAD

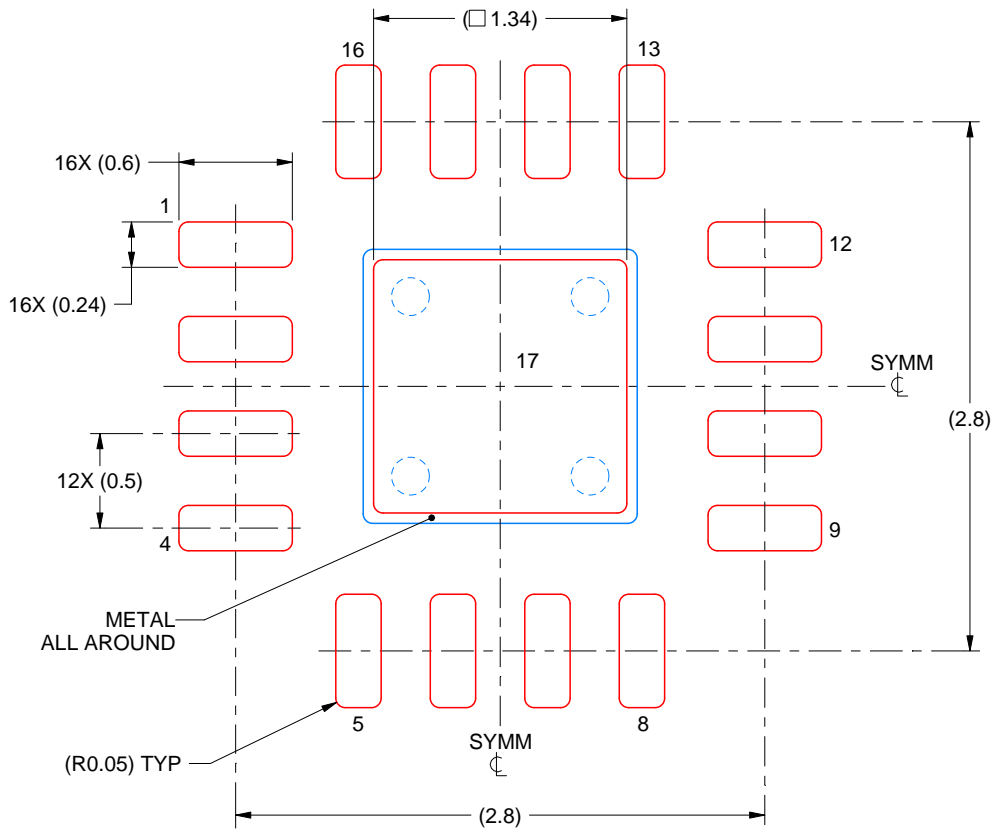

**SOLDER PASTE EXAMPLE**  
BASED ON 0.125 mm THICK STENCIL

EXPOSED PAD 17:  
86% PRINTED SOLDER COVERAGE BY AREA UNDER PACKAGE  
SCALE:25X

4219032/A 02/2017

NOTES: (continued)

7. Laser cutting apertures with trapezoidal walls and rounded corners may offer better paste release. IPC-7525 may have alternate design recommendations.

## IMPORTANT NOTICE

Texas Instruments Incorporated (TI) reserves the right to make corrections, enhancements, improvements and other changes to its semiconductor products and services per JESD46, latest issue, and to discontinue any product or service per JESD48, latest issue. Buyers should obtain the latest relevant information before placing orders and should verify that such information is current and complete.

TI's published terms of sale for semiconductor products (<http://www.ti.com/sc/docs/stdterms.htm>) apply to the sale of packaged integrated circuit products that TI has qualified and released to market. Additional terms may apply to the use or sale of other types of TI products and services.

Reproduction of significant portions of TI information in TI data sheets is permissible only if reproduction is without alteration and is accompanied by all associated warranties, conditions, limitations, and notices. TI is not responsible or liable for such reproduced documentation. Information of third parties may be subject to additional restrictions. Resale of TI products or services with statements different from or beyond the parameters stated by TI for that product or service voids all express and any implied warranties for the associated TI product or service and is an unfair and deceptive business practice. TI is not responsible or liable for any such statements.

Buyers and others who are developing systems that incorporate TI products (collectively, "Designers") understand and agree that Designers remain responsible for using their independent analysis, evaluation and judgment in designing their applications and that Designers have full and exclusive responsibility to assure the safety of Designers' applications and compliance of their applications (and of all TI products used in or for Designers' applications) with all applicable regulations, laws and other applicable requirements. Designer represents that, with respect to their applications, Designer has all the necessary expertise to create and implement safeguards that (1) anticipate dangerous consequences of failures, (2) monitor failures and their consequences, and (3) lessen the likelihood of failures that might cause harm and take appropriate actions. Designer agrees that prior to using or distributing any applications that include TI products, Designer will thoroughly test such applications and the functionality of such TI products as used in such applications.

TI's provision of technical, application or other design advice, quality characterization, reliability data or other services or information, including, but not limited to, reference designs and materials relating to evaluation modules, (collectively, "TI Resources") are intended to assist designers who are developing applications that incorporate TI products; by downloading, accessing or using TI Resources in any way, Designer (individually or, if Designer is acting on behalf of a company, Designer's company) agrees to use any particular TI Resource solely for this purpose and subject to the terms of this Notice.

TI's provision of TI Resources does not expand or otherwise alter TI's applicable published warranties or warranty disclaimers for TI products, and no additional obligations or liabilities arise from TI providing such TI Resources. TI reserves the right to make corrections, enhancements, improvements and other changes to its TI Resources. TI has not conducted any testing other than that specifically described in the published documentation for a particular TI Resource.

Designer is authorized to use, copy and modify any individual TI Resource only in connection with the development of applications that include the TI product(s) identified in such TI Resource. NO OTHER LICENSE, EXPRESS OR IMPLIED, BY ESTOPPEL OR OTHERWISE TO ANY OTHER TI INTELLECTUAL PROPERTY RIGHT, AND NO LICENSE TO ANY TECHNOLOGY OR INTELLECTUAL PROPERTY RIGHT OF TI OR ANY THIRD PARTY IS GRANTED HEREIN, including but not limited to any patent right, copyright, mask work right, or other intellectual property right relating to any combination, machine, or process in which TI products or services are used. Information regarding or referencing third-party products or services does not constitute a license to use such products or services, or a warranty or endorsement thereof. Use of TI Resources may require a license from a third party under the patents or other intellectual property of the third party, or a license from TI under the patents or other intellectual property of TI.

TI RESOURCES ARE PROVIDED "AS IS" AND WITH ALL FAULTS. TI DISCLAIMS ALL OTHER WARRANTIES OR REPRESENTATIONS, EXPRESS OR IMPLIED, REGARDING RESOURCES OR USE THEREOF, INCLUDING BUT NOT LIMITED TO ACCURACY OR COMPLETENESS, TITLE, ANY EPIDEMIC FAILURE WARRANTY AND ANY IMPLIED WARRANTIES OF MERCHANTABILITY, FITNESS FOR A PARTICULAR PURPOSE, AND NON-INFRINGEMENT OF ANY THIRD PARTY INTELLECTUAL PROPERTY RIGHTS. TI SHALL NOT BE LIABLE FOR AND SHALL NOT DEFEND OR INDEMNIFY DESIGNER AGAINST ANY CLAIM, INCLUDING BUT NOT LIMITED TO ANY INFRINGEMENT CLAIM THAT RELATES TO OR IS BASED ON ANY COMBINATION OF PRODUCTS EVEN IF DESCRIBED IN TI RESOURCES OR OTHERWISE. IN NO EVENT SHALL TI BE LIABLE FOR ANY ACTUAL, DIRECT, SPECIAL, COLLATERAL, INDIRECT, PUNITIVE, INCIDENTAL, CONSEQUENTIAL OR EXEMPLARY DAMAGES IN CONNECTION WITH OR ARISING OUT OF TI RESOURCES OR USE THEREOF, AND REGARDLESS OF WHETHER TI HAS BEEN ADVISED OF THE POSSIBILITY OF SUCH DAMAGES.

Unless TI has explicitly designated an individual product as meeting the requirements of a particular industry standard (e.g., ISO/TS 16949 and ISO 26262), TI is not responsible for any failure to meet such industry standard requirements.

Where TI specifically promotes products as facilitating functional safety or as compliant with industry functional safety standards, such products are intended to help enable customers to design and create their own applications that meet applicable functional safety standards and requirements. Using products in an application does not by itself establish any safety features in the application. Designers must ensure compliance with safety-related requirements and standards applicable to their applications. Designer may not use any TI products in life-critical medical equipment unless authorized officers of the parties have executed a special contract specifically governing such use. Life-critical medical equipment is medical equipment where failure of such equipment would cause serious bodily injury or death (e.g., life support, pacemakers, defibrillators, heart pumps, neurostimulators, and implantables). Such equipment includes, without limitation, all medical devices identified by the U.S. Food and Drug Administration as Class III devices and equivalent classifications outside the U.S.

TI may expressly designate certain products as completing a particular qualification (e.g., Q100, Military Grade, or Enhanced Product). Designers agree that it has the necessary expertise to select the product with the appropriate qualification designation for their applications and that proper product selection is at Designers' own risk. Designers are solely responsible for compliance with all legal and regulatory requirements in connection with such selection.

Designer will fully indemnify TI and its representatives against any damages, costs, losses, and/or liabilities arising out of Designer's non-compliance with the terms and provisions of this Notice.

## Looking for pricing, stock, or lifecycle information?

Click below to explore more details on WIN SOURCE:

 [View THS4511RGTT on WIN SOURCE](#)

 [Texas Instruments](#) Information

## Optimize Your Supply Chain with WIN SOURCE Solutions

-  Global Sourcing Solution
-  Obsolete Management
-  Cost Control Management
-  Shortage Management
-  Alternative Solution
-  Excess Inventory Management