



**THE DATASHEET OF
TLV620612TDSGRQ1**



TLV620612-Q1 1.2-V Fixed Output Voltage, 3-MHz 1.6 A Step-Down Converter in 2-mm x 2-mm WSON Package

1 Features

- Qualified for Automotive Applications
- AEC-Q100 Test Guidance With the Following Results:
 - Device Temperature Grade 2: -40°C to $+105^{\circ}\text{C}$ Ambient Operating Temperature Range
 - Device HBM ESD Classification Level 2
 - Device CDM ESD Classification Level C4B
- V_{IN} Range from 2.9 to 5.5 V
- Up to 88% Efficiency
- Power-Save Mode or Fixed Frequency PWM Mode
- Output Voltage Accuracy in PWM Mode $\pm 2\%$
- Output Capacitor Discharge Function
- Typical 18- μA Quiescent Current
- Clock Dithering
- For Adjustable Output Voltage Version, See TLV62065-Q1
- Available in a 2-mm x 2-mm x 0.75-mm 8-Pin WSON

2 Applications

- Automotive Infotainment and Cluster
- Advanced Driver Assistance System (ADAS)
- Automotive Display

Typical Application Circuit

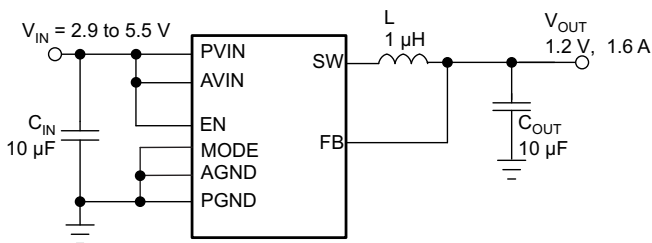

Copyright © 2016, Texas Instruments Incorporated

3 Description

The TLV620612-Q1 device is a highly efficient, synchronous step-down, DC-DC converter with a 1.2-V fixed output voltage. The device provides up to 1.6 A of output current.

With an input voltage range of 2.9 to 5.5 V, the device is a perfect fit for power conversion from a 5-V or 3.3-V system supply rail. The TLV620612-Q1 device operates at 3-MHz fixed frequency and enters power-save mode operation at light-load currents to maintain high efficiency over the entire load current range. For low-noise applications, the TLV620612-Q1 device can be forced into fixed-frequency PWM mode by pulling the MODE pin high.

In shutdown mode, the current consumption is reduced to less than 1 μA and an internal circuit discharges the output capacitor.

The TLV620612-Q1 device uses minimal board space by being available in a convenient 8-pin WSON package and operating with a small inductor (1 μH , typical) and output capacitor (10 μF , typical).

Device Information⁽¹⁾

PART NUMBER	PACKAGE	BODY SIZE (NOM)
TLV620612-Q1	WSON (8)	2.00 mm x 2.00 mm

(1) For all available packages, see the orderable addendum at the end of the datasheet.

Efficiency vs Load Current

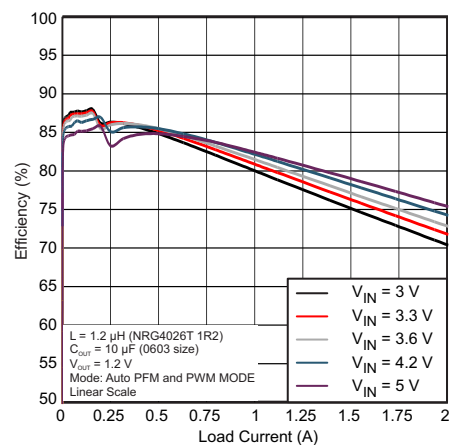

Table of Contents

1 Features	1	7.4 Device Functional Modes.....	13
2 Applications	1	8 Application and Implementation	15
3 Description	1	8.1 Application Information.....	15
4 Revision History	2	8.2 Typical Application	15
5 Pin Configuration and Functions	4	9 Power Supply Recommendations	18
6 Specifications	5	10 Layout	18
6.1 Absolute Maximum Ratings	5	10.1 Layout Guidelines	18
6.2 ESD Ratings.....	5	10.2 Layout Example	18
6.3 Recommended Operating Conditions.....	5	11 Device and Documentation Support	19
6.4 Thermal Information	5	11.1 Documentation Support	19
6.5 Electrical Characteristics.....	6	11.2 Receiving Notification of Documentation Updates	19
6.6 Switching Characteristics	6	11.3 Community Resource.....	19
6.7 Typical Characteristics	7	11.4 Trademarks	19
7 Detailed Description	11	11.5 Electrostatic Discharge Caution.....	19
7.1 Overview	11	11.6 Glossary	19
7.2 Functional Block Diagram	11	12 Mechanical, Packaging, and Orderable	19
7.3 Feature Description.....	12	Information	19

4 Revision History

NOTE: Page numbers for previous revisions may differ from page numbers in the current version.

Changes from Revision B (December 2014) to Revision C	Page
• Changed the maximum efficiency from 97% to 88%	1
• Changed the maximum output current from 2 A to 1.6 A throughout the data sheet	1
• Changed the FB pin description in the <i>Pin Functions</i> table	4
• Changed the output voltage in the <i>Recommended Operating Conditions</i> to 1.2 V and removed all references to other output voltages (V_{OUT}). Updated graphics where applicable.....	5
• Deleted the junction temperature from the <i>Recommended Operating Conditions</i> table	5
• Changed the <i>Thermal Information</i> values	5
• Changed the typical reference voltage value from 1.2 V to 600 mV	6
• Changed graphs to show input voltage up to 5.5 V instead of 6 V in the <i>Typical Characteristics</i> section	8
• Deleted the <i>Parameter Measurement Information</i> section because the circuit is similar to the application circuit in the <i>Typical Application</i> section	11
• Added a description of the clock dithering feature to the <i>Feature Description</i> section	12
• Deleted the <i>100% Duty Cycle Low-Dropout Operation</i> section from the <i>Feature Description</i> section	12
• Deleted the <i>Output Voltage Setting</i> section in the <i>Detailed Design Procedure</i> section.....	15
• Added the <i>Receiving Notification of Documentation Updates</i> section	19
• Changed the ESDS caution statement	19

Changes from Revision A (March 2012) to Revision B	Page
• Added the <i>Pin Configuration and Functions</i> section, <i>ESD Ratings</i> table, <i>Feature Description</i> section, <i>Device Functional Modes</i> , <i>Application and Implementation</i> section, <i>Power Supply Recommendations</i> section, <i>Layout</i> section, <i>Device and Documentation Support</i> section, and <i>Mechanical, Packaging, and Orderable Information</i> section	1

Changes from Original (January 2012) to Revision A**Page**

• Updated automotive qualification description and add temperature grade and Update Typical Application Circuit	1
• Update Absolute Maximum Ratings	5
• Update Electrical Characteristics - Shutdown current max rating	6
• Update reference voltage spec in the Electrical Characteristics table	6
• Update figure, remove RC feedback divider in the Parameter Measurement Information section	15
• Update reference voltage calculation and remove RC divider feedback description in the Output Voltage Setting section	15

5 Pin Configuration and Functions

**DSG Package
8-Pin WSON With Exposed Thermal Pad
Top View**

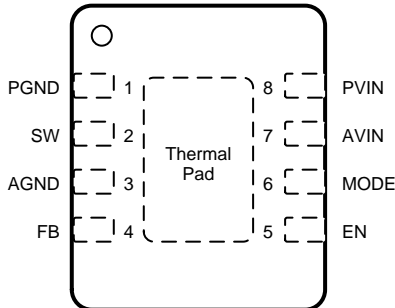

Pin Functions

PIN		TYPE	DESCRIPTION
NAME	NO.		
AGND	3	IN	Analog GND supply pin for the control circuit.
AV _{IN}	7	IN	Analog V _{IN} power supply for the control circuit. This pin must be connected to the PV _{IN} pin and the input capacitor.
EN	5	IN	EN is the enable pin of the device. Pulling this pin low forces the device into shutdown mode. Pulling this pin high enables the device. This pin must be terminated.
FB	4	IN	Feedback pin for the internal regulation loop. Connect this pin directly to the output capacitor.
MODE	6	IN	When the MODE pin is high, the device is forced to operate in fixed-frequency PWM mode. When the MODE pin is low, the device enters the power-save mode with automatic transition from PFM mode to fixed-frequency PWM mode. This pin must be terminated.
PGND	1	PWR	GND supply pin for the output stage
PV _{IN}	8	PWR	V _{IN} power-supply pin for the output stage
SW	2	OUT	SW is the switch pin and is connected to the internal MOSFET switches. Connect the external inductor between this pin and the output capacitor.
Thermal pad		—	For good thermal performance, this pad must be soldered to the land pattern on the PCB. This pad should be used as device GND.

6 Specifications

6.1 Absolute Maximum Ratings

over operating free-air temperature range (unless otherwise noted)⁽¹⁾

		MIN	MAX	UNIT
Voltage ⁽²⁾	AVIN, PVIN	-0.3	7	V
	EN, MODE, FB	-0.3	(VIN + 0.3) < 7	
	SW	-0.3	7	
Current (source)	Peak output	Internally limited		A
Junction temperature, TJ		-40	140	°C
Storage temperature, Tstg		-65	150	°C

- (1) Stresses beyond those listed under *Absolute Maximum Ratings* may cause permanent damage to the device. These are stress ratings only, and functional operation of the device at these or any other conditions beyond those indicated under *Recommended Operating Conditions* is not implied. Exposure to absolute-maximum-rated conditions for extended periods may affect device reliability.
- (2) All voltage values are with respect to the network ground pin.

6.2 ESD Ratings

			VALUE	UNIT	
V(ESD)	Electrostatic discharge	Human body model (HBM), per AEC Q100-002 ⁽¹⁾	±2000	V	
		Charged device model (CDM), per AEC Q100-011	Corner pins (1, 4, 5, and 8)		±750
			Other pins		±500

- (1) AEC Q100-002 indicates HBM stressing is done in accordance with the ANSI/ESDA/JEDEC JS-001 specification.

6.3 Recommended Operating Conditions

		MIN	NOM	MAX	UNIT
AVIN, PVIN	Supply voltage	2.9		5.5	V
	Output current capability			1600	mA
	Output voltage		1.2		V
L	Effective inductance	0.7	1	1.6	μH
COU	Effective output-capacitance	4.5	10	22	μF
TA	Operating ambient temperature ⁽¹⁾	-40		105	°C

- (1) In applications where high power dissipation, poor package thermal resistance, or both are present, the maximum ambient temperature may have to be derated. Maximum ambient temperature (TA(max)) is dependent on the maximum operating junction temperature (TJ(max)), the maximum power dissipation of the device in the application (PD(max)), and the junction-to-ambient thermal resistance of the device or package in the application (RθJA), as given by the following equation: TA(max) = TJ(max) - (RθJA × PD(max))

6.4 Thermal Information

THERMAL METRIC ⁽¹⁾		TLV620612-Q1	UNIT
		DSG (WSON)	
		8 PINS	
RθJA	Junction-to-ambient thermal resistance	61.9	°C/W
RθJC(top)	Junction-to-case(top) thermal resistance	76.3	°C/W
RθJB	Junction-to-board thermal resistance	32.4	°C/W
ψJT	Junction-to-top characterization parameter	1.6	°C/W
ψJB	Junction-to-board characterization parameter	32.9	°C/W
RθJC(bot)	Junction-to-case(bottom) thermal resistance	6.7	°C/W

- (1) For more information about traditional and new thermal metrics, see the [Semiconductor and IC Package Thermal Metrics](#) application report.

6.5 Electrical Characteristics

Over full operating ambient temperature range, typical values are at $T_A = 25^\circ\text{C}$. Unless otherwise noted, specifications apply for condition $V_{IN} = EN = 3.6\text{ V}$. External components $C_{IN} = 10\ \mu\text{F}$ 0603, $C_{OUT} = 10\ \mu\text{F}$ 0603, $L = 1\ \mu\text{H}$, see .

PARAMETER		TEST CONDITIONS	MIN	TYP	MAX	UNIT
SUPPLY						
V_{IN}	Input voltage range		2.9		5.5	V
I_Q	Operating quiescent current	$I_{OUT} = 0\text{ mA}$, device operating in PFM mode and not device not switching		18		μA
I_{SD}	Shutdown current	EN = GND, current into AVIN and PVIN combined		0.1	5	μA
V_{UVLO}	Undervoltage lockout threshold	Falling	1.73	1.78	1.83	V
		Rising	1.9	1.95	1.99	
ENABLE, MODE						
V_{IH}	High-level input voltage	$2.9\text{ V} \leq V_{IN} \leq 5.5\text{ V}$	1		5.5	V
V_{IL}	Low-level input voltage	$2.9\text{ V} \leq V_{IN} \leq 5.5\text{ V}$	0		0.4	V
I_{IN}	Input bias current	EN, MODE tied to GND or AVIN		0.01	1	μA
POWER SWITCH						
$r_{DS(on)}$	High-side MOSFET on-resistance	$V_{IN} = 3.6\text{ V}^{(1)}$		120	180	$\text{m}\Omega$
		$V_{IN} = 5\text{ V}^{(1)}$		95	150	
$r_{DS(on)}$	Low-side MOSFET on-resistance	$V_{IN} = 3.6\text{ V}^{(1)}$		90	130	$\text{m}\Omega$
		$V_{IN} = 5\text{ V}^{(1)}$		75	100	
I_{LIMF}	Forward current limit MOSFET high-side and low-side	$3\text{ V} \leq V_{IN} \leq 3.6\text{ V}$	2000	2170		mA
T_{SD}	Thermal shutdown	Increasing junction temperature		150		$^\circ\text{C}$
	Thermal shutdown hysteresis	Decreasing junction temperature		10		
OUTPUT						
V_{OUT}	Output voltage			1.2		V
V_{ref}	Reference voltage			600		mV
$V_{FB(PWM)}$	Feedback voltage, PWM mode	PWM operation, MODE = V_{IN} , $2.9\text{ V} \leq V_{IN} \leq 5.5\text{ V}$, 0-mA load	-2%	0%	2%	
$V_{FB(PFM)}$	Feedback voltage, PFM mode, voltage positioning	Device in PFM mode, voltage positioning active ⁽²⁾		1%		
V_{FB}	Load regulation			-0.5		%/A
	Line regulation			0		%/V
$R_{(Discharge)}$	Internal discharge resistor	Activated with EN = GND, $2.9\text{ V} \leq V_{IN} \leq 5.5\text{ V}$, $0.8\text{ V} \leq V_{OUT} \leq 3.6\text{ V}$		200		Ω

(1) Maximum value applies for $T_J = 85^\circ\text{C}$.

(2) In PFM mode, the internal reference voltage is set to typ. $1.01 \times V_{ref}$. See the [Application and Implementation](#) section.

6.6 Switching Characteristics

over operating free-air temperature range (unless otherwise noted)

PARAMETER		TEST CONDITIONS	MIN	TYP	MAX	UNIT
OSCILLATOR						
f_{SW}	Oscillator frequency	$2.9\text{ V} \leq V_{IN} \leq 5.5\text{ V}$	2.6	3	3.4	MHz
OUTPUT						
t_{START}	Startup time	Time from active EN to reach 95% of V_{OUT}		500		μs

6.7 Typical Characteristics

Table 1. Table of Graphs

		FIGURE
Shutdown Current	Input Voltage and Ambient Temperature	Figure 1
Quiescent Current	Input Voltage	Figure 2
η Efficiency	Load Current, $V_{OUT} = 1.2\text{ V}$, Auto PF//PWM Mode, Linear Scale	Figure 3
Oscillator Frequency	Input Voltage	Figure 4
Static Drain-Source On-State Resistance	Input Voltage, Low-Side Switch	Figure 5
	Input Voltage, High-Side Switch	Figure 6
$R_{DISCHARGE}$	Input Voltage	Figure 7
Typical Operation	PWM Mode, $V_{IN} = 3.6\text{ V}$, $V_{OUT} = 1.2\text{ V}$, 500 mA, $L = 1.2\text{ }\mu\text{H}$, $C_{OUT} = 10\text{ }\mu\text{F}$	Figure 8
	PFM Mode, $V_{IN} = 3.6\text{ V}$, $V_{OUT} = 1.2\text{ V}$, 20 mA, $L = 1.2\text{ }\mu\text{H}$, $C_{OUT} = 10\text{ }\mu\text{F}$	Figure 9
Load Transient	PWM Mode, $V_{IN} = 3.6\text{ V}$, $V_{OUT} = 1.2\text{ V}$, 0.2 A to 1 A	Figure 10
	PFM Mode, $V_{IN} = 3.6\text{ V}$, $V_{OUT} = 1.2\text{ V}$, 20 mA to 250 mA	Figure 11
	$V_{IN} = 3.6\text{ V}$, $V_{OUT} = 1.2\text{ V}$, 200 mA to 1500 mA	Figure 12
Line Transient	PWM Mode, $V_{IN} = 3.6\text{ V}$ to 4.2 V, $V_{OUT} = 1.2\text{ V}$, 500 mA	Figure 13
	PFM Mode, $V_{IN} = 3.6\text{ V}$ to 4.2 V, $V_{OUT} = 1.2\text{ V}$, 500 mA	Figure 14
Startup into Load	$V_{IN} = 3.6\text{ V}$, $V_{OUT} = 1.2\text{ V}$, Load = 2.2- Ω	Figure 15
Output Discharge	$V_{IN} = 3.6\text{ V}$, $V_{OUT} = 1.2\text{ V}$, No Load	Figure 16

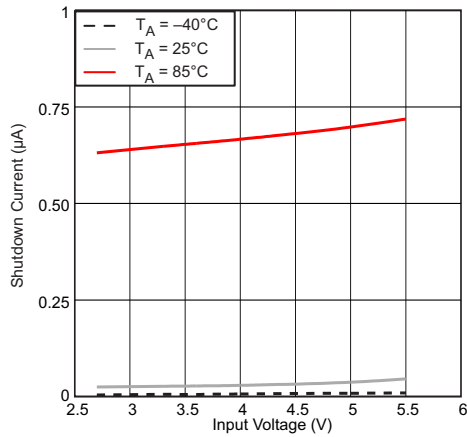

Figure 1. Shutdown Current vs Input Voltage and Ambient Temperature

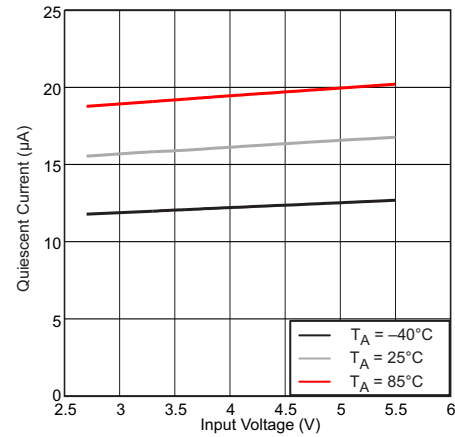
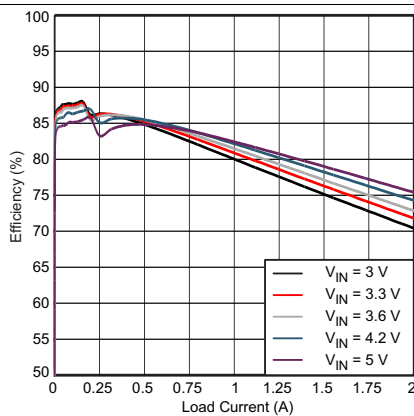

Figure 2. Quiescent Current vs Input Voltage



L = 1.2 µH (NRG4026T 1R2) C_{OUT} = 10 µF (0603 size)

Figure 3. Efficiency vs Load Current
Auto PFM and PWM MODE

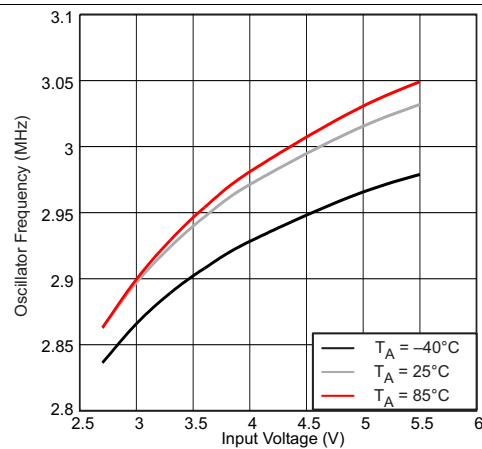
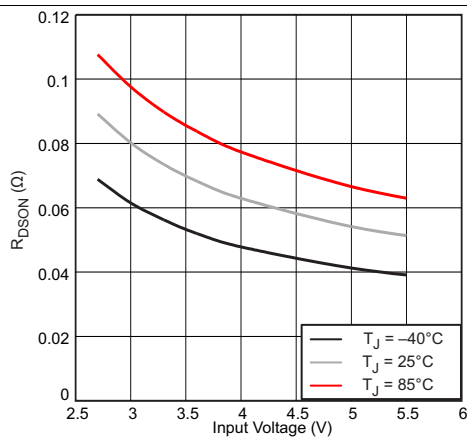
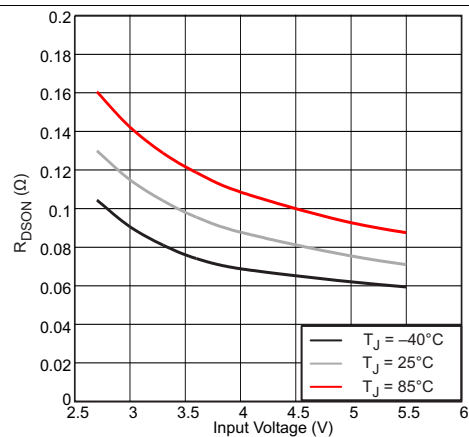

Figure 4. Oscillator Frequency vs Input Voltage



Low-Side Switch

Figure 5. Static Drain-Source On-State Resistance vs Input Voltage



High-Side Switch

Figure 6. Static Drain-Source On-State Resistance vs Input Voltage

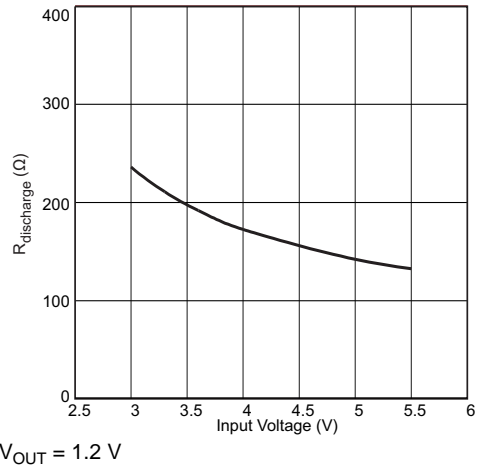

Figure 7. R_{DISCHARGE} vs Input Voltage

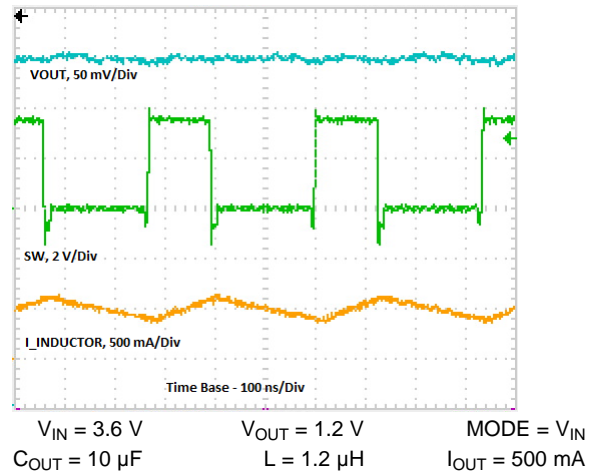

Figure 8. Typical Operation (PWM Mode)

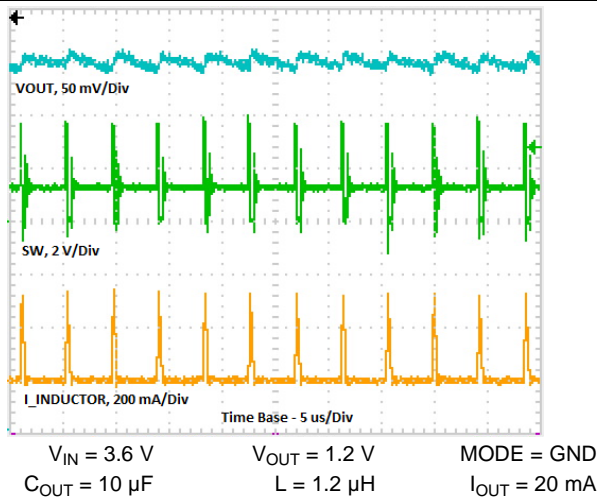

Figure 9. Typical Operation (PFM Mode)

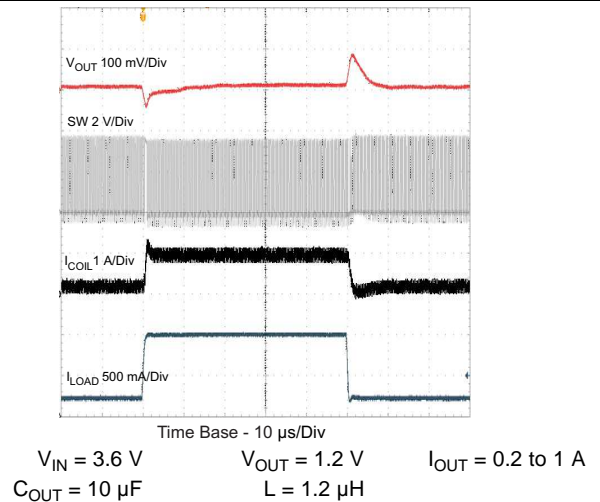

Figure 10. Load Transient Response, MODE = V_{IN} PWM Mode 0.2 A To 1 A

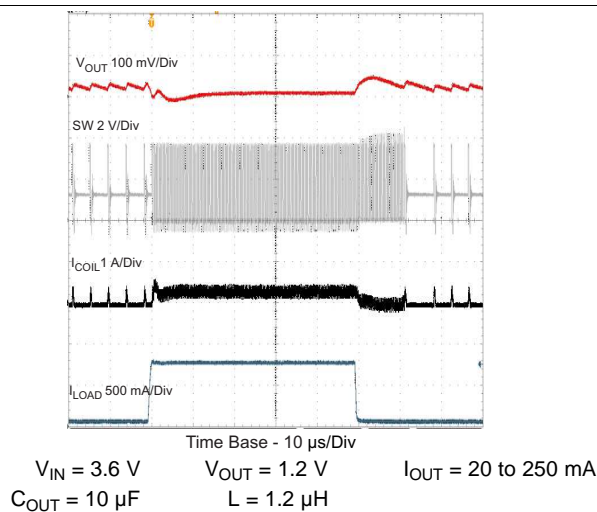

Figure 11. Load Transient PFM Mode 20 mA to 250 mA

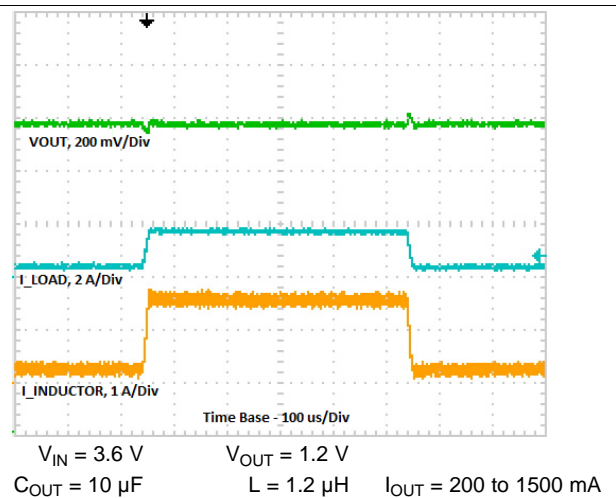
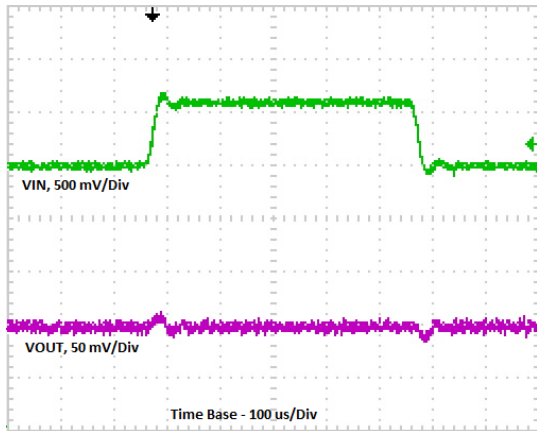
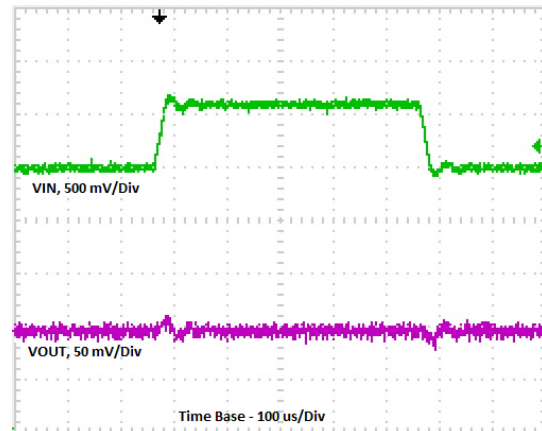

Figure 12. Load Transient Response 200 mA To 1500 mA



$V_{IN} = 3.6 \text{ to } 4.2 \text{ V}$ $V_{OUT} = 1.2 \text{ V}$ $I_{OUT} = 500 \text{ mA}$
 $C_{OUT} = 10 \mu\text{F}$ $L = 1.2 \mu\text{H}$

Figure 13. Line Transient Response PWM Mode



$V_{IN} = 3.6 \text{ to } 4.2 \text{ V}$ $V_{OUT} = 1.2 \text{ V}$ $I_{OUT} = 500 \text{ mA}$
 $C_{OUT} = 10 \mu\text{F}$ $L = 1.2 \mu\text{H}$

Figure 14. Line Transient PFM Mode

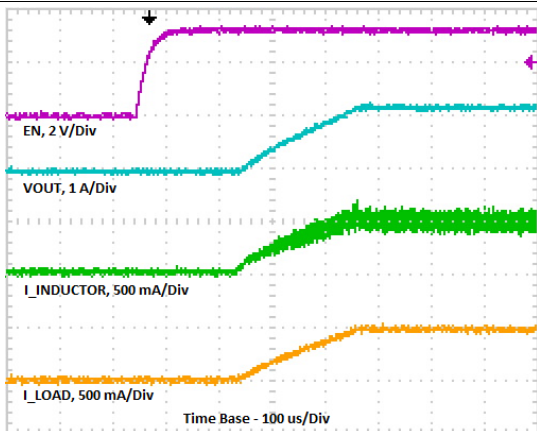

$V_{IN} = 3.6 \text{ V}$ $V_{OUT} = 1.2 \text{ V}$ Load = 2.2Ω
 $C_{OUT} = 10 \mu\text{F}$ $L = 1.2 \mu\text{H}$

Figure 15. Startup Into Load

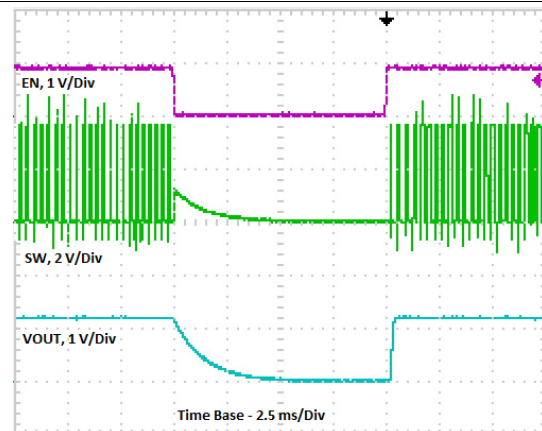

$V_{IN} = 3.6 \text{ V}$ $V_{OUT} = 1.2 \text{ V}$ No load
 $C_{OUT} = 10 \mu\text{F}$ $L = 1.2 \mu\text{H}$

Figure 16. Output Discharge

7 Detailed Description

7.1 Overview

The TLV620612-Q1 step-down converter operates with a typical 3-MHz fixed-frequency pulse-width modulation (PWM) at moderate to heavy load currents. At light load currents, the converter can automatically enter power-save mode, and then operates in pulse-frequency mode (PFM).

During PWM operation, the converter uses a unique fast-response voltage-mode controller scheme with input voltage feed-forward to achieve good line and load regulation, allowing the use of small ceramic input and output capacitors. At the beginning of each clock cycle, the high-side MOSFET switch is turned on. The current now flows from the input capacitor through the high-side MOSFET switch through the inductor to the output capacitor and load. During this phase, the current ramps up until the PWM comparator trips and the control logic turns off the switch. The current-limit comparator also turns off the switch in case the current-limit of the high-side MOSFET switch is exceeded. After a dead time preventing shoot-through current, the low-side MOSFET rectifier is turned on and the inductor current ramps down. The current now flows from the inductor to the output capacitor and to the load. The current returns back to the inductor through the low-side MOSFET rectifier.

The next cycle is initiated by the clock signal again turning off the low-side MOSFET rectifier and turning on the high-side MOSFET switch.

7.2 Functional Block Diagram

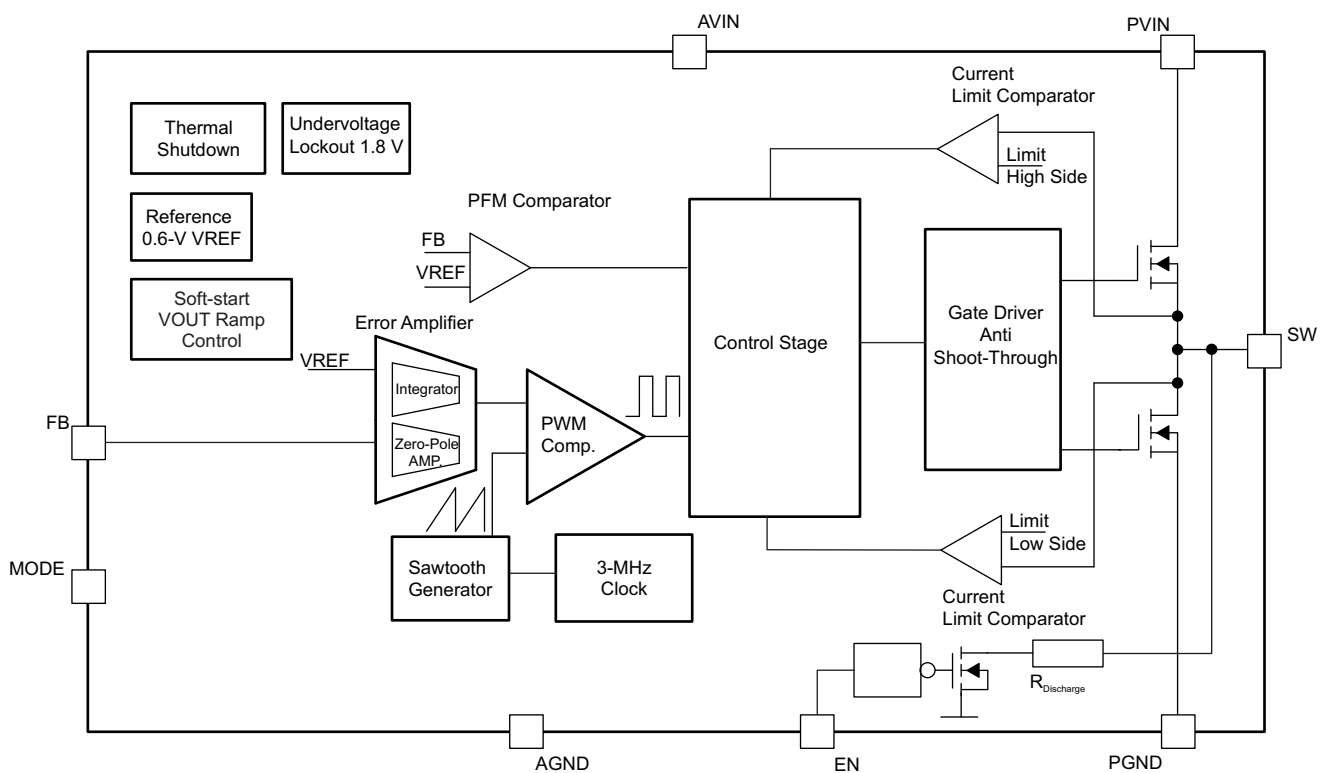

Copyright © 2016, Texas Instruments Incorporated

7.3 Feature Description

7.3.1 Enable

The device is enabled by setting the EN pin high. At first, the internal reference is activated and the internal analog circuits are settled. Afterwards, the soft start is activated and the output voltage is ramped up. The output voltage reaches 95% of the nominal value within t_{START} of typically 500 μs after the device has been enabled. The EN input can be used to control power sequencing in a system with various DC-DC converters. To drive the EN pin high and get a sequencing of supply rails, connect the EN pin to the output of another converter. With EN = GND, the device enters shutdown mode. In this mode, all circuits are disabled and the SW pin is connected to PGND through an internal resistor to discharge the output.

7.3.2 Mode Selection

The MODE pin allows mode selection between forced PWM mode and power-save mode.

Connecting this pin to GND enables the power-save mode with automatic transition between PWM and PFM mode. Pulling the MODE pin high forces the converter to operate in fixed-frequency PWM mode even at light load currents which allows simple filtering of the switching frequency for noise-sensitive applications. In this mode, the efficiency is lower compared to the power-save mode during light loads.

The condition of the MODE pin can be changed during operation and allows efficient power management by adjusting the operation mode of the converter to the specific system requirements.

7.3.3 Soft-Start Functionality

The TLV620612-Q1 device has an internal soft-start circuit that controls the ramp-up of the output voltage. When the converter is enabled and the input voltage is above the undervoltage lockout threshold, V_{UVLO} , the output voltage ramps up from 5% to 95% of the nominal value within a t_{Ramp} of 250 μs (typical).

This ramping limits the inrush current in the converter during startup and prevents possible input-voltage drops when a battery or high-impedance power source is used.

During soft start, the switch current limit is reduced to 1/3 of the nominal value, I_{LIMF} , until the output voltage reaches 1/3 of the nominal value. When the output voltage trips this threshold, the device operates with the nominal current-limit, I_{LIMF} .

7.3.4 Internal Current-Limit and Foldback Current-Limit For Short-Circuit Protection

During normal operation, the high-side and low-side MOSFET switches are protected by the current limits, I_{LIMF} . When the high-side MOSFET switch reaches the current limit, it is turned off and the low-side MOSFET switch is turned on. The high-side MOSFET switch can only turn on again when the current in the low-side MOSFET switch decreases below the current-limit, I_{LIMF} . The device is capable of providing peak inductor currents up to the internal-current limit I_{LIMF} .

As soon as the switch-current limits are hit and the output voltage falls below 1/3 of the nominal output voltage because of an overload or short-circuit condition, the foldback current limit is enabled. In this case, the switch-current limit is reduced to 1/3 of the nominal value, I_{LIMF} .

Because the short-circuit protection is enabled during startup, the device does not deliver more than 1/3 of the nominal current-limit, I_{LIMF} , until the output voltage exceeds 1/3 of the nominal output voltage. This must be considered when a load which acts as a current sink is connected to the output of the converter.

7.3.5 Clock Dithering

To reduce the noise level of switch-frequency harmonics in the higher RF bands, the TLV620612-Q1 device has a built-in clock-dithering circuit. The oscillator frequency is slightly modulated with a sub clock which causes a clock dither of ± 3 ns (typical).

Feature Description (continued)

7.3.6 Undervoltage Lockout

The undervoltage lockout (UVLO) circuit prevents the device from malfunctioning at low input voltages and from excessive discharge of the battery. The UVLO circuit disables the output stage of the converter once the falling V_{IN} trips the undervoltage lockout threshold V_{UVLO} . The undervoltage lockout threshold V_{UVLO} for falling V_{IN} is typically 1.78 V. The device begins operation when the rising V_{IN} trips the undervoltage lockout threshold V_{UVLO} again at 1.95 V (typical).

7.3.7 Output Capacitor Discharge

With $EN = GND$, the device enters shutdown mode and disables all internal circuits. An internal resistor connects the SW pin to PGND to discharge the output capacitor. This feature ensures startup with a discharged output capacitor when the converter is enabled again and prevents a *floating* charge on the output capacitor. The output voltage ramps up monotonically, starting from 0 V.

7.3.8 Thermal Shutdown

As soon as the junction temperature, T_J , exceeds 150°C (typical) the device goes into thermal shutdown. In this mode, the high-side and low-side MOSFETs are turned off. The device continues operation with a soft-start when the junction temperature falls below the thermal shutdown hysteresis.

7.4 Device Functional Modes

7.4.1 Power Save Mode

Pulling the TLV620612-Q1 MODE pin low enables power-save mode. If the load current decreases, the converter enters power-save mode operation automatically. In power-save mode, the converter skips switching and operates with reduced frequency in the PFM mode with a minimum quiescent current to maintain high efficiency. The converter positions the output voltage 1% (typical) above the nominal output voltage. This voltage-positioning feature minimizes voltage drops caused by a sudden load step.

The transition from PWM mode to PFM mode occurs when the inductor current in the low-side MOSFET switch becomes zero, which indicates discontinuous conduction mode.

In power-save mode, a PFM comparator monitors the output voltage. As the output voltage falls below the PFM comparator threshold of $V_{OUTnominal} + 1\%$, the device begins a PFM current pulse. For this pulse, the high-side MOSFET switch turns on and the inductor current ramps up. After the on-time expires, the switch is turned off and the low-side MOSFET switch is turned on until the inductor current becomes zero.

The converter effectively delivers a current to the output capacitor and the load. If the load is below the delivered current, the output voltage rises. If the output voltage is equal to or higher than the PFM comparator threshold, the device stops switching and enters a sleep mode with 18- μ A current consumption (typical).

In case the output voltage is still below the PFM comparator threshold, further PFM current pulses are generated until the PFM comparator threshold is reached. The converter begins switching again when the output voltage drops below the PFM comparator threshold because of the load current.

The device leaves PFM mode and goes to PWM mode in case the output current can no longer be supported in PFM mode.

Device Functional Modes (continued)

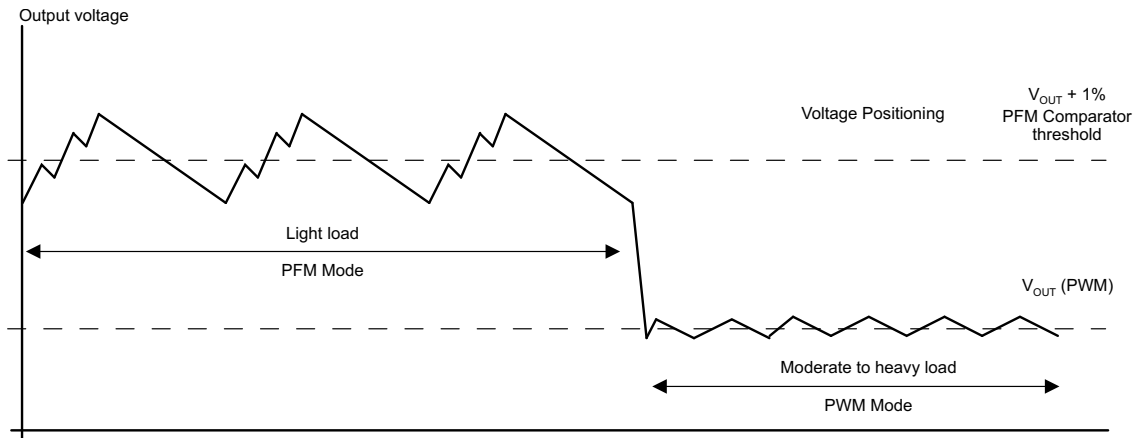

Figure 17. Power Save Mode Operation With Automatic Mode Transition

8 Application and Implementation

NOTE

Information in the following applications sections is not part of the TI component specification, and TI does not warrant its accuracy or completeness. TI's customers are responsible for determining suitability of components for their purposes. Customers should validate and test their design implementation to confirm system functionality.

8.1 Application Information

The TLV620612-Q1 device is a highly efficient, synchronous step-down, DC-DC converter with a 1.2 V fixed output voltage and an output current of 1.6 A. The device can be used in buck converter applications with an input range from 2.9 to 5.5 V.

8.2 Typical Application

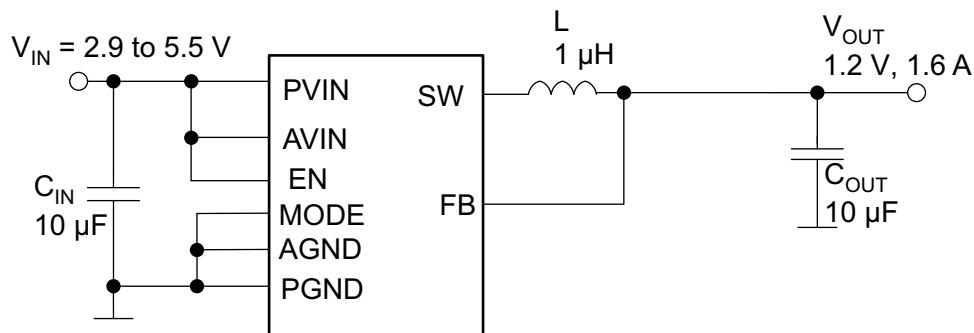

Copyright © 2016, Texas Instruments Incorporated

Figure 18. TLV620612-Q1 1.2-V Fixed Output Voltage Configuration

8.2.1 Design Requirements

The TLV620612-Q1 device enters power-save mode operation at light load currents to maintain high efficiency over the entire load current range. For low noise applications, the TLV620612-Q1 device can be forced into fixed-frequency PWM mode by pulling the MODE pin high. We will demonstrate these aspects in the application curves of the device.

8.2.2 Detailed Design Procedure

8.2.2.1 Output Filter Design (inductor And Output Capacitor)

The internal compensation network of the TLV620612-Q1 device is optimized for an LC output filter with a corner frequency that is calculated with Equation 1

$$f_c = \frac{1}{2 \times \pi \times \sqrt{(1 \mu\text{H} \times 10 \mu\text{F})}} = 50 \text{ kHz} \quad (1)$$

The device operates with nominal inductors of 1 µH to 1.2 µH and with 10 µF to 22 µF small X5R and X7R ceramic capacitors. Table 2 and Table 3 list recommended inductors and capacitors. Users must verify and validate these components for suitability with their application before using the components. The device is optimized for a 1-µH inductor and 10-µF output capacitor.

8.2.2.1.1 Inductor Selection

The inductor value has a direct effect on the ripple current. The selected inductor must be rated for the DC resistance and saturation current. The inductor ripple current (ΔI_L) decreases with higher inductance and increases with higher V_{IN} or V_{OUT} .

Typical Application (continued)

Use Equation 2 to calculate the maximum inductor current in PWM mode under static load conditions. The saturation current of the inductor should be rated higher than the maximum inductor current as calculated with Equation 3. This value is recommended because during heavy load transients the inductor current rises above the calculated value.

$$\Delta I_L = V_{OUT} \times \frac{1 - \frac{V_{OUT}}{V_{IN}}}{L \times f}$$

where

- ΔI_L = Peak-to-peak inductor ripple current
 - L = Inductor value
 - f = Switching frequency (3 MHz typical)
- (2)

$$I_{Lmax} = I_{OUTmax} + \frac{\Delta I_L}{2}$$

where

- I_{Lmax} = Maximum inductor current
- (3)

A more conservative approach is to select the inductor current rating just for the switch-current limit I_{LIMF} of the converter.

The total losses of the coil have a strong impact on the efficiency of the DC-DC conversion and consist of both the losses in the DC resistance $R_{(DC)}$ and the following frequency-dependent components:

- The losses in the core material (magnetic hysteresis loss, especially at high switching frequencies)
- Additional losses in the conductor from the skin effect (current displacement at high frequencies)
- Magnetic field losses of the neighboring windings (proximity effect)
- Radiation losses

Table 2. List of Inductors

DIMENSIONS [mm, maximum]	INDUCTANCE μ H	INDUCTOR TYPE	SUPPLIER
3.2 × 2.5 × 1	1	LQM32PN (MLCC)	Murata
3.7 × 4 × 1.8	1	LQH44 (wire wound)	Murata
4 × 4 × 2.6	1.2	NRG4026T (wire wound)	Taiyo Yuden
3.5 × 3.7 × 1.8	1.2	DE3518 (wire wound)	TOKO

8.2.2.1.2 Output Capacitor Selection

The advanced fast-response voltage-mode control scheme of the TLV620612-Q1 device allows the use of tiny ceramic capacitors. Ceramic capacitors with low ESR values provide the lowest output-voltage ripple and are recommended. The output capacitor requires either an X7R or X5R dielectric. Y5V- and Z5U-dielectric capacitors, aside from a wide variation in capacitance over temperature, become resistive at high frequencies and may not be used. For most applications, a nominal 10- μ F or 22- μ F capacitor is suitable. Table 3 lists recommended capacitors. Users must verify and validate these components for suitability with their application before using the components.

In case additional ceramic capacitors in the supplied system are connected to the output of the DC-DC converter, the output capacitor C_{OUT} must be decreased in order not to exceed the recommended effective capacitance range. In this case, a loop-stability analysis must be performed as described in the [Checking Loop Stability](#) section.

Use Equation 4 to calculate the RMS ripple current at the nominal load current and while the device is in PWM mode.

$$I_{RMSOut} = V_{OUT} \times \frac{1 - \frac{V_{OUT}}{V_{IN}}}{L \times f} \times \frac{1}{2 \times \sqrt{3}}$$
(4)

8.2.2.1.3 Input Capacitor Selection

Because of the nature of the buck converter having a pulsating input current, a low-ESR input capacitor is required for best input voltage filtering and minimizing interference with other circuits caused by high input voltage spikes. For most applications a 10- μF ceramic capacitor is recommended. The input capacitor can be increased without any limit for better input voltage filtering.

Take care when using only small ceramic input capacitors. When a ceramic capacitor is used at the input and the power is being supplied through long wires, such as from a wall adapter, a load step at the output or V_{IN} step on the input can induce ringing at the V_{IN} pin. This ringing can couple to the output and be mistaken as loop instability, or could even damage the part by exceeding the maximum ratings.

Table 3. List of Capacitors

CAPACITANCE	TYPE	SIZE [mm]	SUPPLIER
10 μF	GRM188R60J106M	0603: 1.6 × 0.8 × 0.8	Murata
22 μF	GRM188R60G226M	0603: 1.6 × 0.8 × 0.8	Murata
22 μF	CL10A226MQ8NRNC	0603: 1.6 × 0.8 × 0.8	Samsung
10 μF	CL10A106MQ8NRNC	0603: 1.6 × 0.8 × 0.8	Samsung

8.2.2.2 Checking Loop Stability

The first step of circuit and stability evaluation is to look at the following signals from a steady-state perspective:

- Switching node, SW
- Inductor current, I_L
- Output ripple voltage, $V_{\text{OUT(AC)}}$

These signals are the basic signals that must be measured when evaluating a switching converter. When the switching waveform shows large duty cycle jitter, or the output voltage or inductor current shows oscillations, the regulation loop may be unstable. This instability is often a result of board layout, wrong L-C output filter combinations, or both. As a next step in the evaluation of the regulation loop, the transient response of the load is tested. During the time between the application of the load transient and the turnon of the P-channel MOSFET, the output capacitor must supply all of the current required by the load. V_{OUT} immediately shifts by an amount equal to $\Delta I_{(\text{LOAD})} \times \text{ESR}$, where ESR is the effective series resistance of C_{OUT} . $\Delta I_{(\text{LOAD})}$ begins to charge or discharge C_{O} , generating a feedback error signal used by the regulator to return V_{OUT} to its steady-state value. The results are most easily interpreted when the device operates in PWM mode at medium-to-high load currents.

During this recovery time, V_{OUT} can be monitored for settling time, overshoot, or ringing; that helps evaluate stability of the converter. Without any ringing, the loop has usually more than 45° of phase margin.

8.2.3 Application Curves

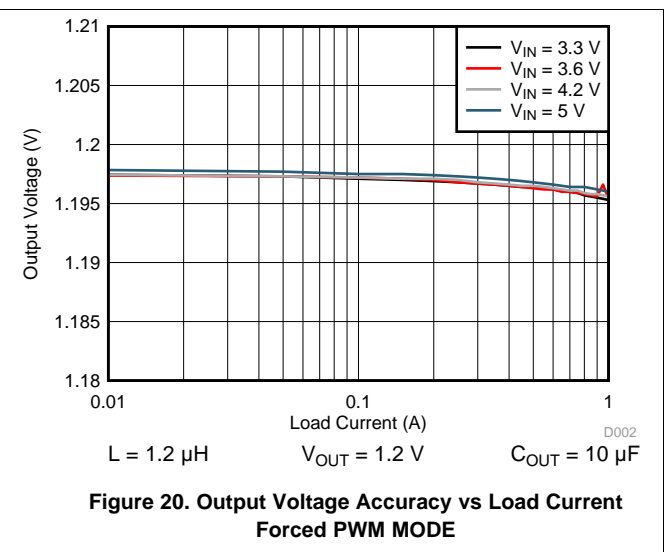
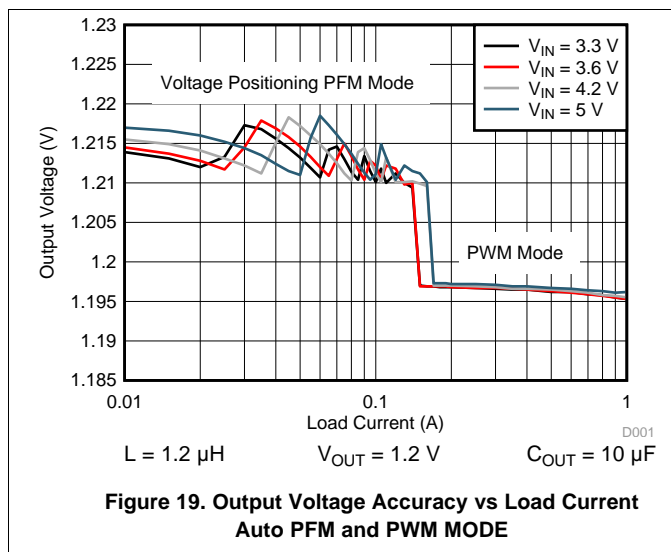

9 Power Supply Recommendations

The TLV620612-Q1 device is designed to operate from an input voltage up to 5.5 V. For the input pins (PVIN and AVIN), a small ceramic capacitor with a typical value of 10 μ F is recommended for most applications. Capacitance derating for aging, temperature, and DC bias must be taken into account while determining the capacitor value.

10 Layout

10.1 Layout Guidelines

As for all switching power supplies, the layout is an important step in the design. Proper function of the device demands careful attention to PCB layout. Care must be taken in board layout to get the specified performance. If the layout is not carefully done, the regulator could show poor line regulation, load regulation or both and may show stability issues as well as EMI and thermal problems.

Figure 21 shows an example of layout design with the TLV620612-Q1 device.

- Providing a low-inductance, low-impedance ground path is critical. Therefore, use wide and short traces for the main current paths. The input capacitor as well as the inductor and output capacitor should be placed as close as possible to the IC pins.
- Connect the AGND and PGND pins of the device to the thermal pad land of the PCB and use this pad as a star point.
- The FB line should be connected directly to the output capacitor and the FB line must be routed away from noisy components and traces (for example, the SW line).
- Because of the small package of this converter and the overall small solution size, the thermal performance of the PCB layout is important. For good thermal performance, PCB design of at least four layers is recommended.
- The thermal pad of the IC must be soldered on the thermal pad area on the PCB to achieve proper thermal connection. Additionally, for good thermal performance, the thermal pad on the PCB must be connected to an inner GND plane with sufficient via connections.

10.2 Layout Example

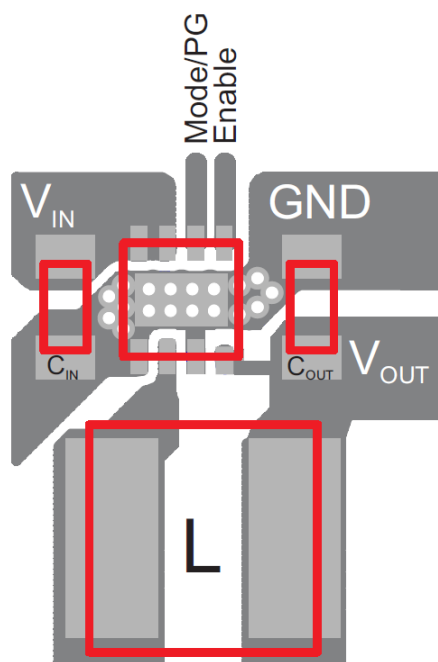

Figure 21. PCB Layout

11 Device and Documentation Support

11.1 Documentation Support

11.1.1 Third-Party Products Disclaimer

TI'S PUBLICATION OF INFORMATION REGARDING THIRD-PARTY PRODUCTS OR SERVICES DOES NOT CONSTITUTE AN ENDORSEMENT REGARDING THE SUITABILITY OF SUCH PRODUCTS OR SERVICES OR A WARRANTY, REPRESENTATION OR ENDORSEMENT OF SUCH PRODUCTS OR SERVICES, EITHER ALONE OR IN COMBINATION WITH ANY TI PRODUCT OR SERVICE.

11.1.2 Related Documentation

For related documentation see the following:

[QFN/SON PCB Attachment](#) (SLUA271)

11.2 Receiving Notification of Documentation Updates

To receive notification of documentation updates, navigate to the device product folder on ti.com. In the upper right corner, click on *Alert me* to register and receive a weekly digest of any product information that has changed. For change details, review the revision history included in any revised document.

11.3 Community Resource

The following links connect to TI community resources. Linked contents are provided "AS IS" by the respective contributors. They do not constitute TI specifications and do not necessarily reflect TI's views; see TI's [Terms of Use](#).

TI E2E™ Online Community *TI's Engineer-to-Engineer (E2E) Community*. Created to foster collaboration among engineers. At e2e.ti.com, you can ask questions, share knowledge, explore ideas and help solve problems with fellow engineers.

Design Support *TI's Design Support* Quickly find helpful E2E forums along with design support tools and contact information for technical support.

11.4 Trademarks

E2E is a trademark of Texas Instruments.

All other trademarks are the property of their respective owners.

11.5 Electrostatic Discharge Caution



This integrated circuit can be damaged by ESD. Texas Instruments recommends that all integrated circuits be handled with appropriate precautions. Failure to observe proper handling and installation procedures can cause damage.

ESD damage can range from subtle performance degradation to complete device failure. Precision integrated circuits may be more susceptible to damage because very small parametric changes could cause the device not to meet its published specifications.

11.6 Glossary

[SLYZ022](#) — *TI Glossary*.

This glossary lists and explains terms, acronyms, and definitions.

12 Mechanical, Packaging, and Orderable Information

The following pages include mechanical, packaging, and orderable information. This information is the most current data available for the designated devices. This data is subject to change without notice and revision of this document. For browser-based versions of this data sheet, refer to the left-hand navigation.

PACKAGING INFORMATION

Orderable Device	Status (1)	Package Type	Package Drawing	Pins	Package Qty	Eco Plan (2)	Lead/Ball Finish (6)	MSL Peak Temp (3)	Op Temp (°C)	Device Marking (4/5)	Samples
TLV620612TDSGRQ1	ACTIVE	WSON	DSG	8	3000	Green (RoHS & no Sb/Br)	CU NIPDAU	Level-2-260C-1 YEAR	-40 to 105	SCA	Samples

(1) The marketing status values are defined as follows:

ACTIVE: Product device recommended for new designs.

LIFEBUY: TI has announced that the device will be discontinued, and a lifetime-buy period is in effect.

NRND: Not recommended for new designs. Device is in production to support existing customers, but TI does not recommend using this part in a new design.

PREVIEW: Device has been announced but is not in production. Samples may or may not be available.

OBSELETE: TI has discontinued the production of the device.

(2) Eco Plan - The planned eco-friendly classification: Pb-Free (RoHS), Pb-Free (RoHS Exempt), or Green (RoHS & no Sb/Br) - please check <http://www.ti.com/productcontent> for the latest availability information and additional product content details.

TBD: The Pb-Free/Green conversion plan has not been defined.

Pb-Free (RoHS): TI's terms "Lead-Free" or "Pb-Free" mean semiconductor products that are compatible with the current RoHS requirements for all 6 substances, including the requirement that lead not exceed 0.1% by weight in homogeneous materials. Where designed to be soldered at high temperatures, TI Pb-Free products are suitable for use in specified lead-free processes.

Pb-Free (RoHS Exempt): This component has a RoHS exemption for either 1) lead-based flip-chip solder bumps used between the die and package, or 2) lead-based die adhesive used between the die and leadframe. The component is otherwise considered Pb-Free (RoHS compatible) as defined above.

Green (RoHS & no Sb/Br): TI defines "Green" to mean Pb-Free (RoHS compatible), and free of Bromine (Br) and Antimony (Sb) based flame retardants (Br or Sb do not exceed 0.1% by weight in homogeneous material)

(3) MSL, Peak Temp. - The Moisture Sensitivity Level rating according to the JEDEC industry standard classifications, and peak solder temperature.

(4) There may be additional marking, which relates to the logo, the lot trace code information, or the environmental category on the device.

(5) Multiple Device Markings will be inside parentheses. Only one Device Marking contained in parentheses and separated by a "-" will appear on a device. If a line is indented then it is a continuation of the previous line and the two combined represent the entire Device Marking for that device.

(6) Lead/Ball Finish - Orderable Devices may have multiple material finish options. Finish options are separated by a vertical ruled line. Lead/Ball Finish values may wrap to two lines if the finish value exceeds the maximum column width.

Important Information and Disclaimer:The information provided on this page represents TI's knowledge and belief as of the date that it is provided. TI bases its knowledge and belief on information provided by third parties, and makes no representation or warranty as to the accuracy of such information. Efforts are underway to better integrate information from third parties. TI has taken and continues to take reasonable steps to provide representative and accurate information but may not have conducted destructive testing or chemical analysis on incoming materials and chemicals. TI and TI suppliers consider certain information to be proprietary, and thus CAS numbers and other limited information may not be available for release.

In no event shall TI's liability arising out of such information exceed the total purchase price of the TI part(s) at issue in this document sold by TI to Customer on an annual basis.

TAPE AND REEL INFORMATION



QUADRANT ASSIGNMENTS FOR PIN 1 ORIENTATION IN TAPE

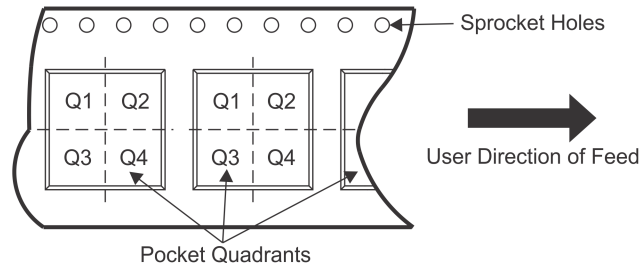

*All dimensions are nominal

Device	Package Type	Package Drawing	Pins	SPQ	Reel Diameter (mm)	Reel Width W1 (mm)	A0 (mm)	B0 (mm)	K0 (mm)	P1 (mm)	W (mm)	Pin1 Quadrant
TLV620612TDSGRQ1	WSON	DSG	8	3000	179.0	8.4	2.2	2.2	1.2	4.0	8.0	Q2

TAPE AND REEL BOX DIMENSIONS



*All dimensions are nominal

Device	Package Type	Package Drawing	Pins	SPQ	Length (mm)	Width (mm)	Height (mm)
TLV620612TDSGRQ1	WSON	DSG	8	3000	195.0	200.0	45.0

GENERIC PACKAGE VIEW

DSG 8

WSON - 0.8 mm max height

2 x 2, 0.5 mm pitch

PLASTIC SMALL OUTLINE - NO LEAD

This image is a representation of the package family, actual package may vary.
Refer to the product data sheet for package details.

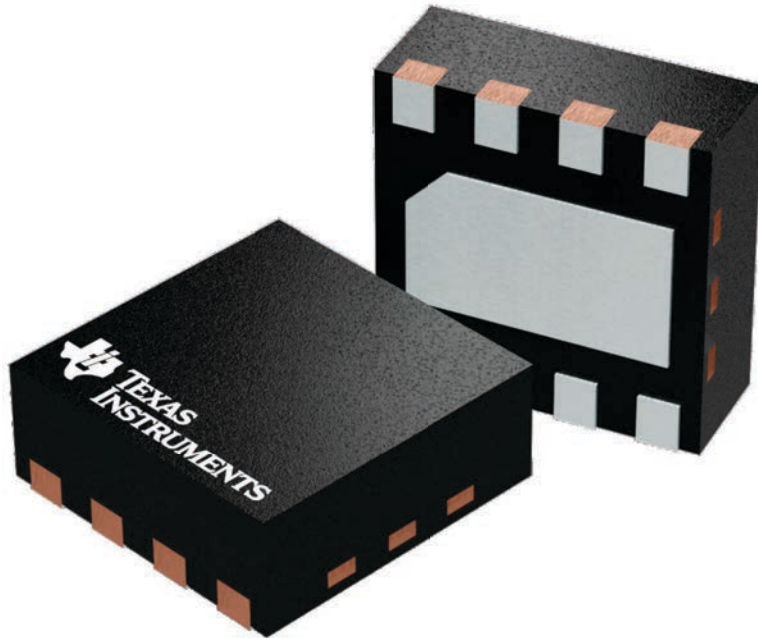

4224783/A

DSG0008A

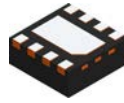

PACKAGE OUTLINE

WSON - 0.8 mm max height

PLASTIC SMALL OUTLINE - NO LEAD

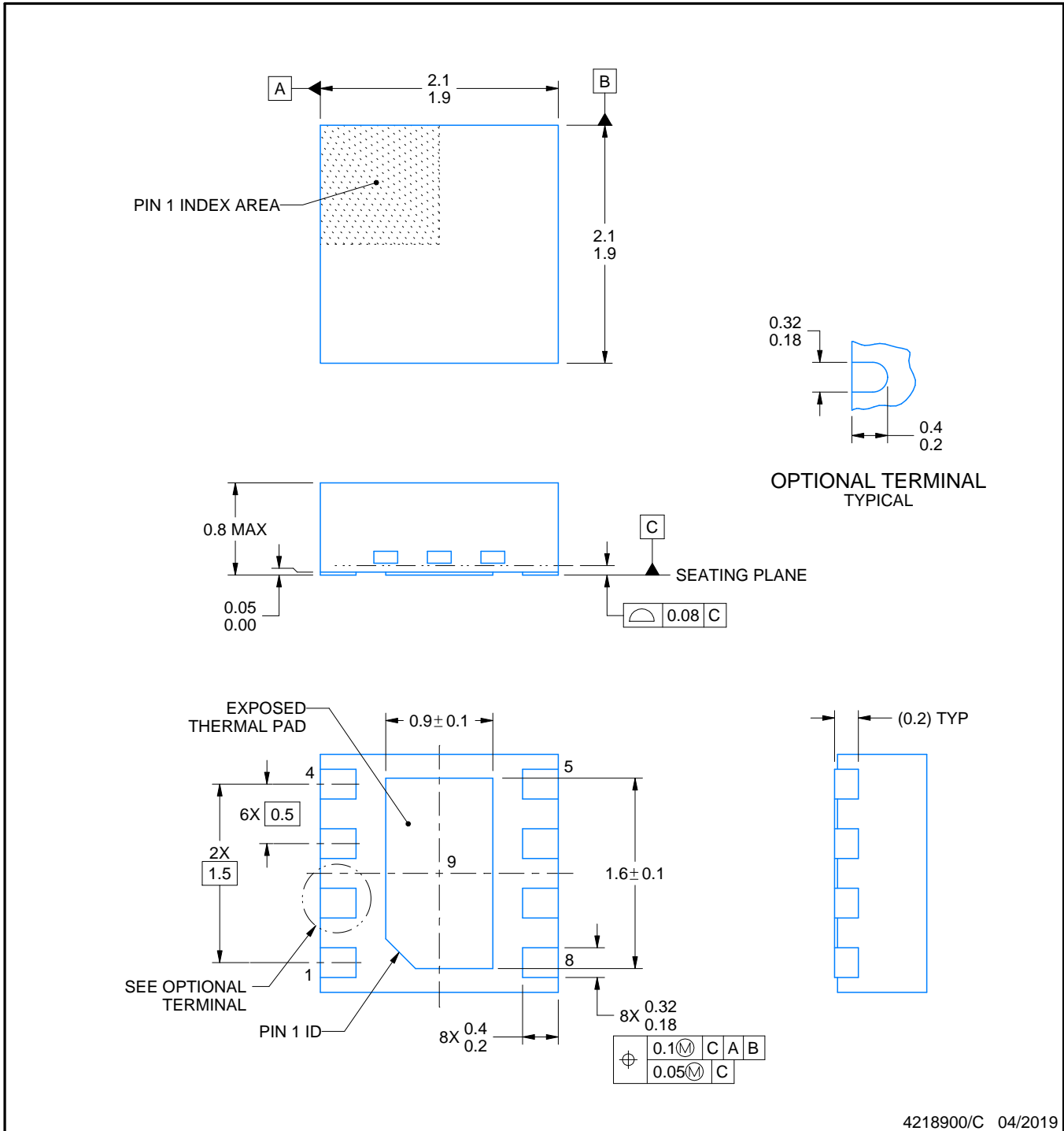

NOTES:

1. All linear dimensions are in millimeters. Any dimensions in parenthesis are for reference only. Dimensioning and tolerancing per ASME Y14.5M.
2. This drawing is subject to change without notice.
3. The package thermal pad must be soldered to the printed circuit board for thermal and mechanical performance.

EXAMPLE BOARD LAYOUT

DSG0008A

WSON - 0.8 mm max height

PLASTIC SMALL OUTLINE - NO LEAD

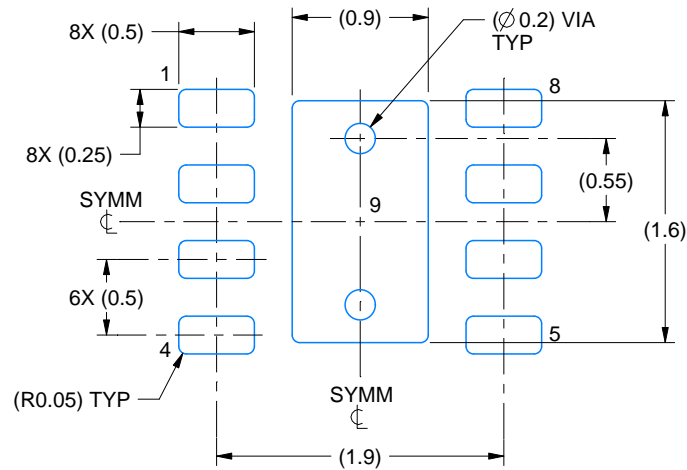

LAND PATTERN EXAMPLE
SCALE:20X

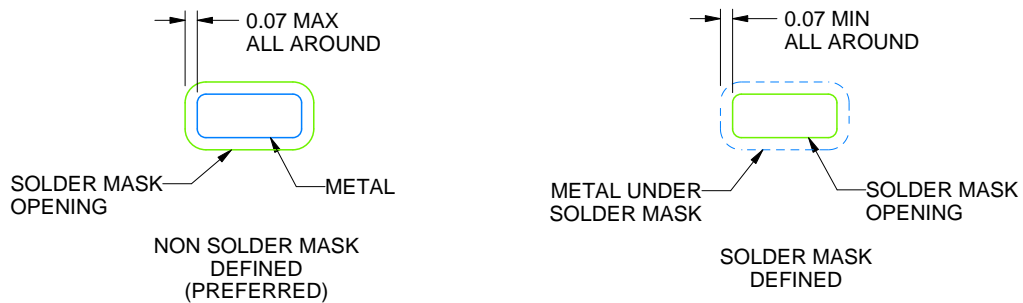

SOLDER MASK DETAILS

4218900/C 04/2019

NOTES: (continued)

4. This package is designed to be soldered to a thermal pad on the board. For more information, see Texas Instruments literature number SLUA271 (www.ti.com/lit/slua271).
5. Vias are optional depending on application, refer to device data sheet. If any vias are implemented, refer to their locations shown on this view. It is recommended that vias under paste be filled, plugged or tented.

EXAMPLE STENCIL DESIGN

DSG0008A

WSON - 0.8 mm max height

PLASTIC SMALL OUTLINE - NO LEAD

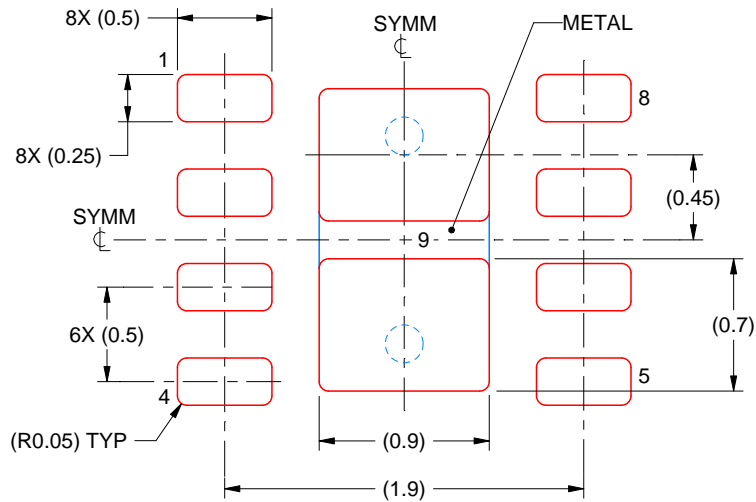

SOLDER PASTE EXAMPLE
BASED ON 0.125 mm THICK STENCIL

EXPOSED PAD 9:
87% PRINTED SOLDER COVERAGE BY AREA UNDER PACKAGE
SCALE:25X

4218900/C 04/2019

NOTES: (continued)

6. Laser cutting apertures with trapezoidal walls and rounded corners may offer better paste release. IPC-7525 may have alternate design recommendations.

IMPORTANT NOTICE AND DISCLAIMER

TI PROVIDES TECHNICAL AND RELIABILITY DATA (INCLUDING DATASHEETS), DESIGN RESOURCES (INCLUDING REFERENCE DESIGNS), APPLICATION OR OTHER DESIGN ADVICE, WEB TOOLS, SAFETY INFORMATION, AND OTHER RESOURCES "AS IS" AND WITH ALL FAULTS, AND DISCLAIMS ALL WARRANTIES, EXPRESS AND IMPLIED, INCLUDING WITHOUT LIMITATION ANY IMPLIED WARRANTIES OF MERCHANTABILITY, FITNESS FOR A PARTICULAR PURPOSE OR NON-INFRINGEMENT OF THIRD PARTY INTELLECTUAL PROPERTY RIGHTS.

These resources are intended for skilled developers designing with TI products. You are solely responsible for (1) selecting the appropriate TI products for your application, (2) designing, validating and testing your application, and (3) ensuring your application meets applicable standards, and any other safety, security, or other requirements. These resources are subject to change without notice. TI grants you permission to use these resources only for development of an application that uses the TI products described in the resource. Other reproduction and display of these resources is prohibited. No license is granted to any other TI intellectual property right or to any third party intellectual property right. TI disclaims responsibility for, and you will fully indemnify TI and its representatives against, any claims, damages, costs, losses, and liabilities arising out of your use of these resources.

TI's products are provided subject to TI's Terms of Sale (www.ti.com/legal/termsofsale.html) or other applicable terms available either on ti.com or provided in conjunction with such TI products. TI's provision of these resources does not expand or otherwise alter TI's applicable warranties or warranty disclaimers for TI products.

Mailing Address: Texas Instruments, Post Office Box 655303, Dallas, Texas 75265
Copyright © 2019, Texas Instruments Incorporated

Looking for pricing, stock, or lifecycle information?

Click below to explore more details on WIN SOURCE:

 [View TLV620612TDSGRQ1 on WIN SOURCE](#)

 [Texas Instruments](#) Information

Optimize Your Supply Chain with WIN SOURCE Solutions

-  Global Sourcing Solution
-  Obsolete Management
-  Cost Control Management
-  Shortage Management
-  Alternative Solution
-  Excess Inventory Management