



THE DATASHEET OF TDE1747DP



INTERFACE CIRCUIT – RELAY AND LAMP – DRIVER

- OPEN GROUND PROTECTION
- HIGH OUTPUT CURRENT
- ADJUSTABLE SHORT-CIRCUIT PROTECTION TO GROUND
- THERMAL PROTECTION WITH HYSTERESIS TO AVOID THE INTERMEDIATE OUTPUT LEVELS
- LARGE SUPPLY VOLTAGE RANGE : + 10 V TO + 45 V
- SHORT-CIRCUIT PROTECTION TO V_{CC}

DESCRIPTION

The TDE/TDF1747 is a monolithic comparator designed for high current and high voltage applications, specifically to drive lamps, relays, stepping motors.

This device is essentially blow-out proof. Current limiting is available to limit the peak output current to safe values, the adjustment only requires one external resistor. In addition, thermal shut down is provided to keep the I.C. from overheating. If internal dissipation becomes too great, the driver will shut down to prevent excessive heating. TDE1747 has an open ground protection. The output is also protected from short-circuits with the positive power supply.

PIN CONNECTIONS (Top view)

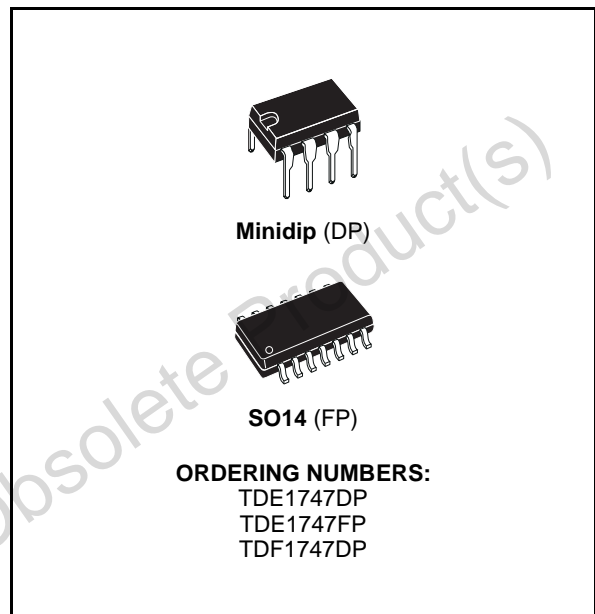
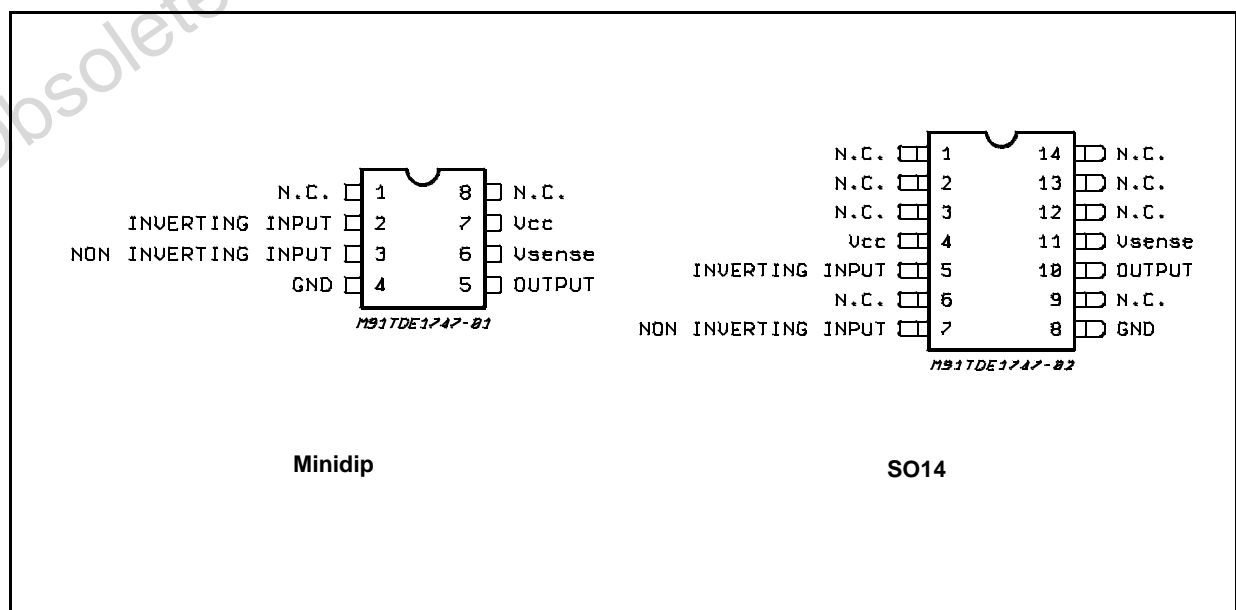

The device operates over a wide range of supply voltages from standard ± 15 V operational amplifier supplies down to the single + 12 V or + 24 used for industrial electronic systems.

TDE1747 - TDF1747

ABSOLUTE MAXIMUM RATINGS

Symbol	Parameter	Value	Unit
V _{CC}	Supply Voltage	50 *	V
V _{ID}	Differential Input Voltage	50	V
V _I	Input Voltage	50	V
I _O	Output Current	1	A
P _{tot}	Power Dissipation (T _{amb} = + 25 °C)	Internally Limited	W
T _{stg}	Storage Temperature Range	- 65 to + 150	°C
T _{oper}	Operating Ambient Temperature Range TDE1747 TDF1747	- 25 to + 85 - 40 to + 85	°C °C

(*) 60V, t à 10ms

THERMAL CHARACTERISTICS

Symbol	Parameter	Value	Unit
R _{th(j-c)}	Maximum Junction-case Thermal Resistance	50	°C/W
R _{th(j-a)}	Maximum Junction-ambient Thermal Resistance	120	°C/W
R _{th}	Junction-ceramic Substrate (case glued to substrate) SO14	90	°C/W
R _{th}	Junction-ceramic Substrate (case glued to substrate, substrate temperature maintained constant) SO14	65	°C/W

SCHEMATIC DIAGRAM

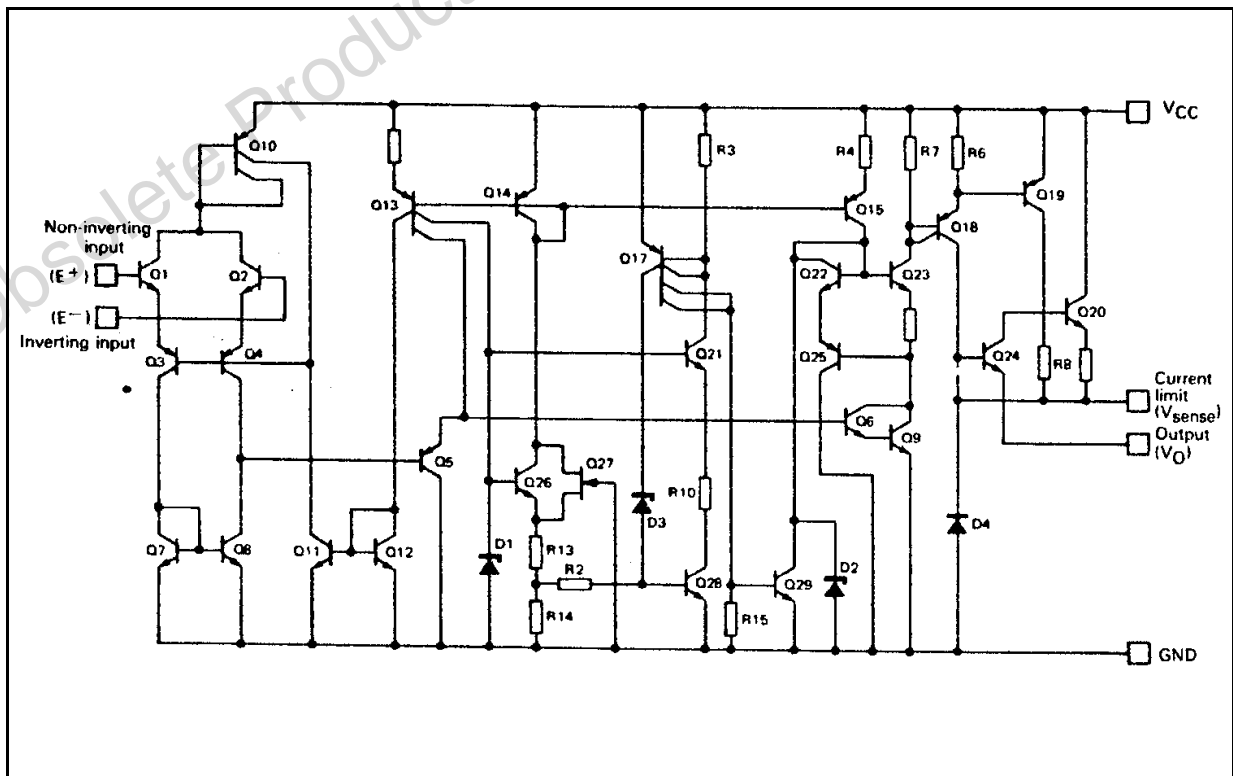

TEST CIRCUIT

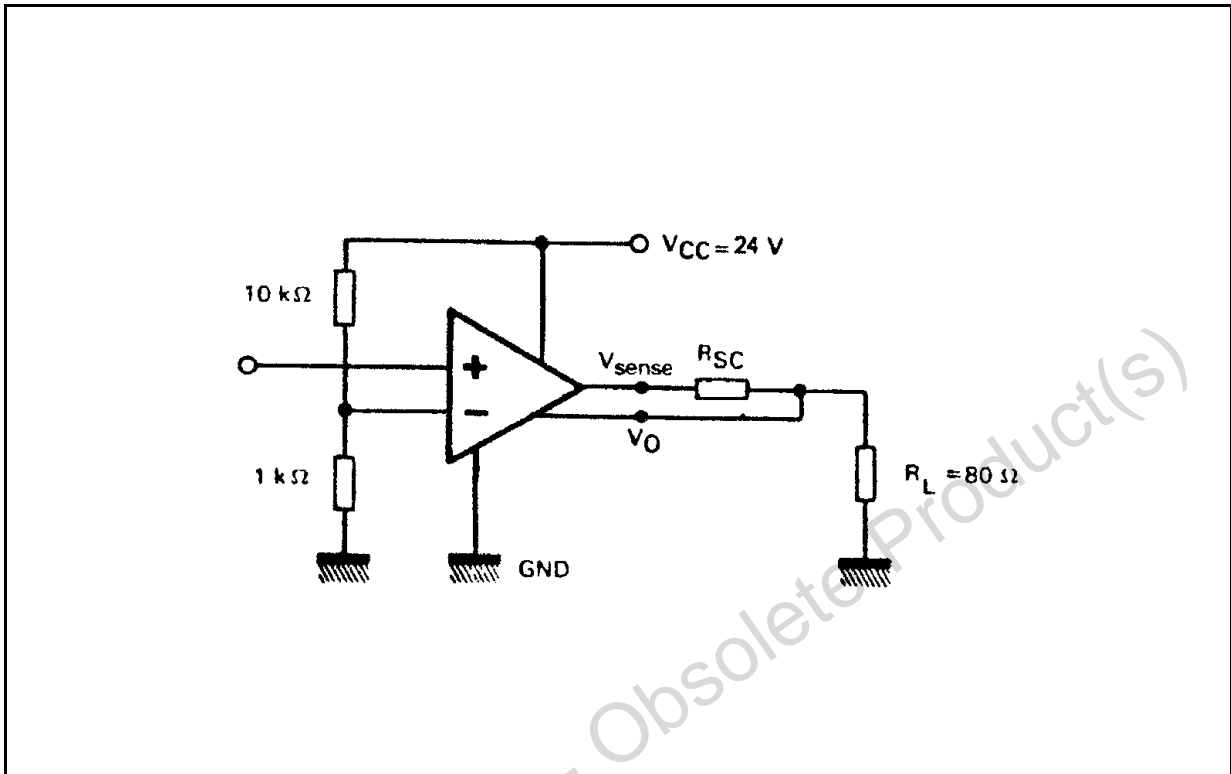

SIMPLIFIED CIRCUIT

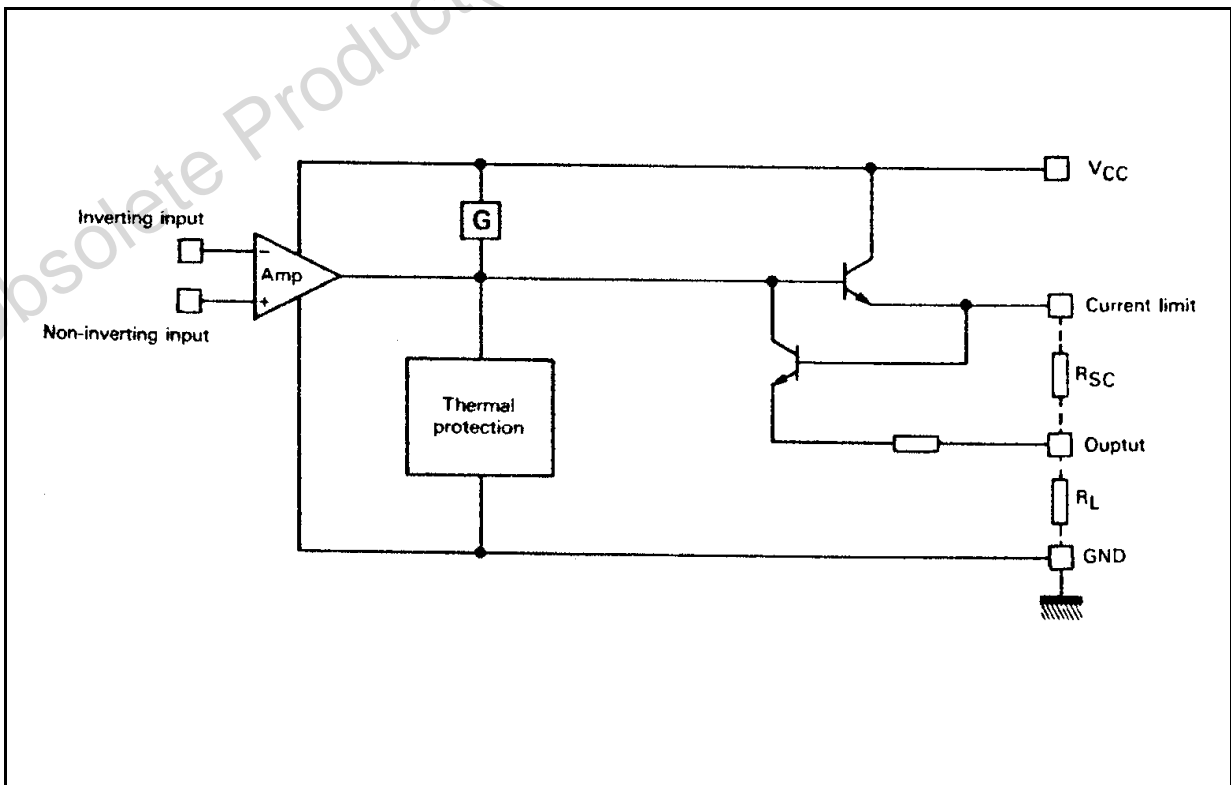

ELECTRICAL CHARACTERISTICS $T_j = -25$ to $+85$ °C, $V_{CC} = 8$ to 45 V, unless otherwise specified (note 1).

Symbol	Parameter	Min.	Typ.	Max.	Unit
V_{IO}	Input Offset Voltage - (note 2)	-	2	50	mV
I_B	Input Bias Current	-	0.1	1.5	mA
I_{CC}	Supply Current ($V_{CC} = +24$ V, $I_O = 0$)				
	High Level	-	4	6	mA
	Low Level	-	2	4	mA
$V_{I(max)}$	Common-mode Input Voltage Range	2	-	$V_{CC}-2$	V
I_{SC}	Short-circuit Current Limit ($T_{amb} = +25$ °C, $V_{CC} = +24$) $R_{SC} = 1.5$ Ω $R_{SC} = \infty$				
		TDE1747	-	480	-
		-	35	50	mA
$V_{CC}-V_O$	Output Saturation Voltage (output high) ($R_{SC} = 0$, $V_I+V_I- \geq 50$ mV) $I_O = 300$ mA, $T_j = +25$ °C $T_j = +150$ °C				
		-	1.15	1.4	V
		-	1.05	1.3	V
I_{OL}	Low Level Output Current ($V_O = 0$, $V_{CC} = +24$ V) $T_j = +25$ °C	-	0.01	10	μA

Notes :

1) For operating at high temperature, the TDE/TDF1747, must be derated based on a $+150$ C maximum junction temperature and a junction-ambient thermal resistance of 120 °C/W for Minidip and 100 °C/W for the SO14.

2) The offset voltage given is the maximum value of input voltage required to drive the output voltage within 2 V of the ground or the supply voltage.

Figure 1: Available Output Current vs. Limiting Resistor

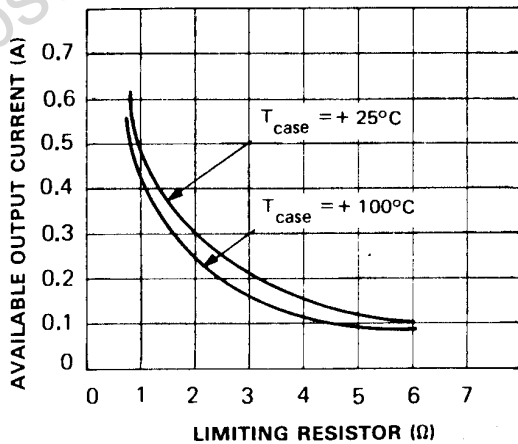

Figure 2: Peak Short-circuit Output Current vs. Limiting Resistor

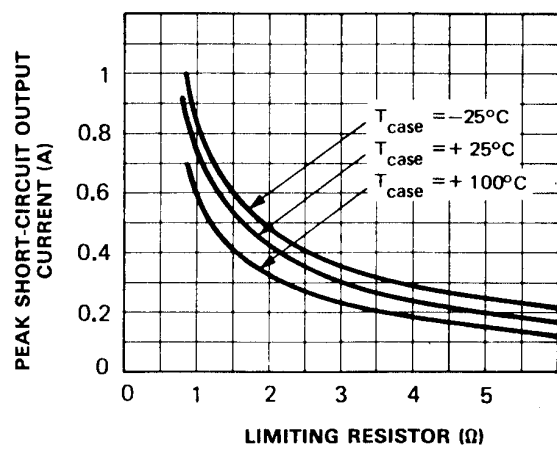

Figure 3: Short-circuit Current vs. Case Temperature

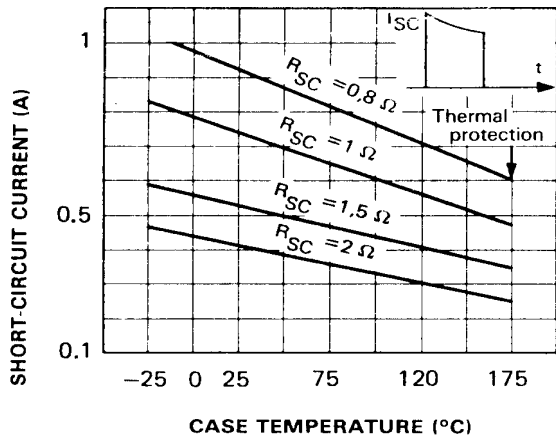

Figure 4: Minimum Limiting Resistor Value vs. Supply Voltage

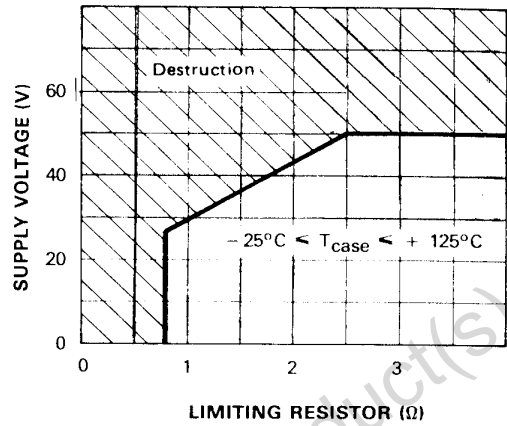

Figure 5: Output Current vs. Output Saturation Voltage

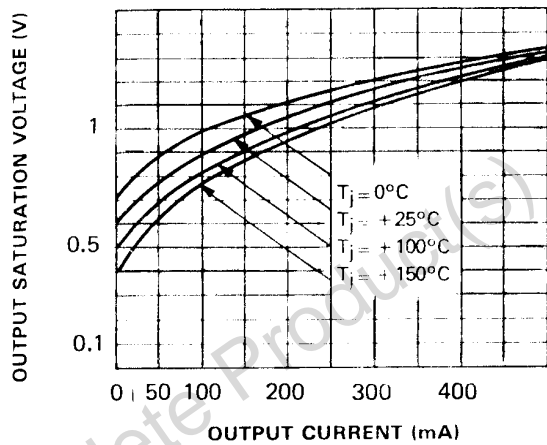

Figure 6: Supply Current vs. Supply Voltage

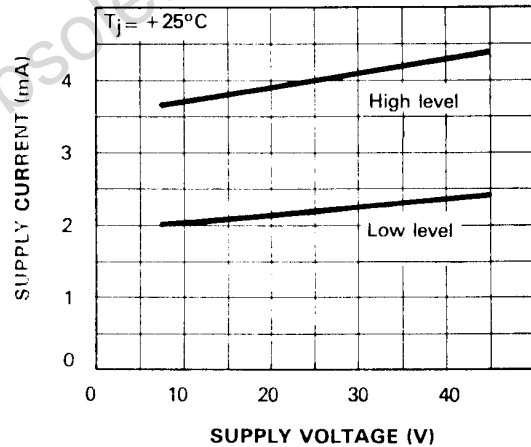

Figure 7: Supply Current vs. Junction Temperature

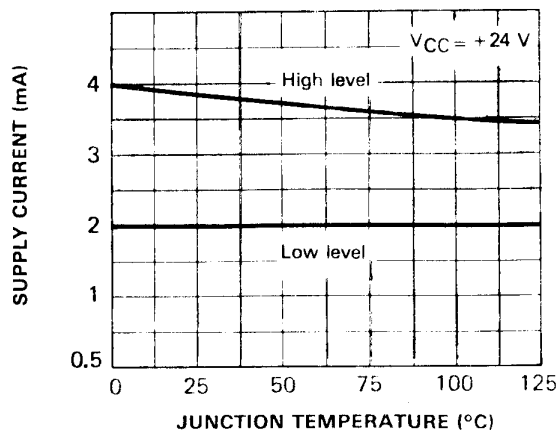

Figure 8: Safe Operating Area (non repetitive surge)

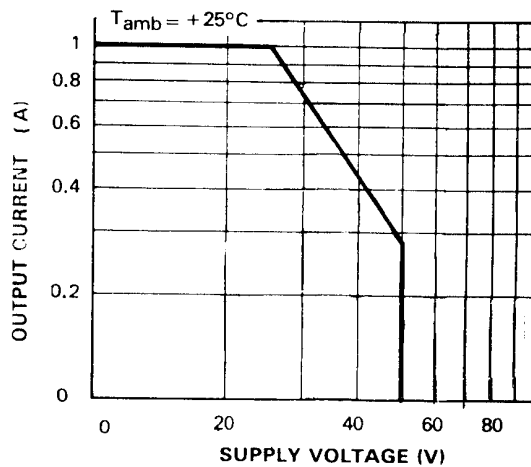
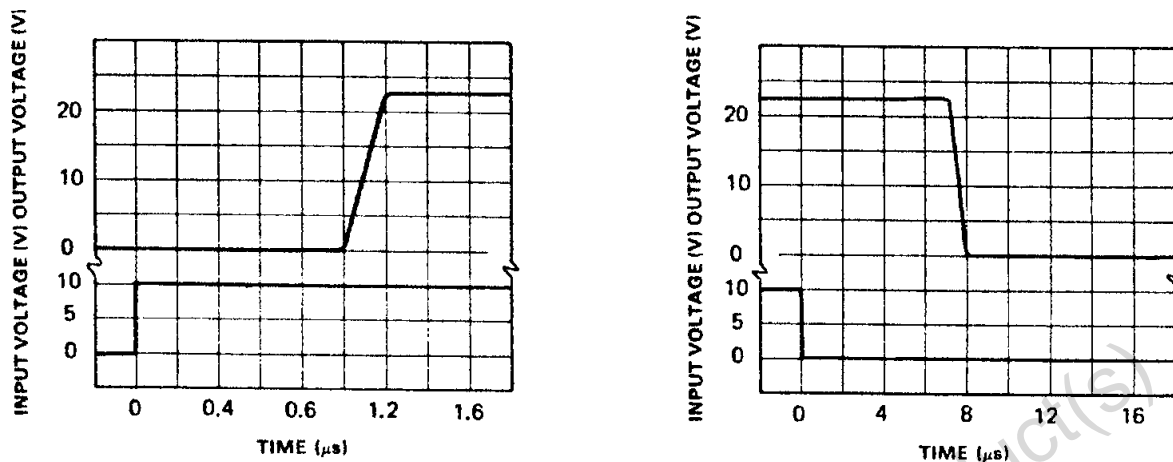

Figure 9: Response Time



TYPICAL APPLICATIONS

Figure 10: Base Circuit

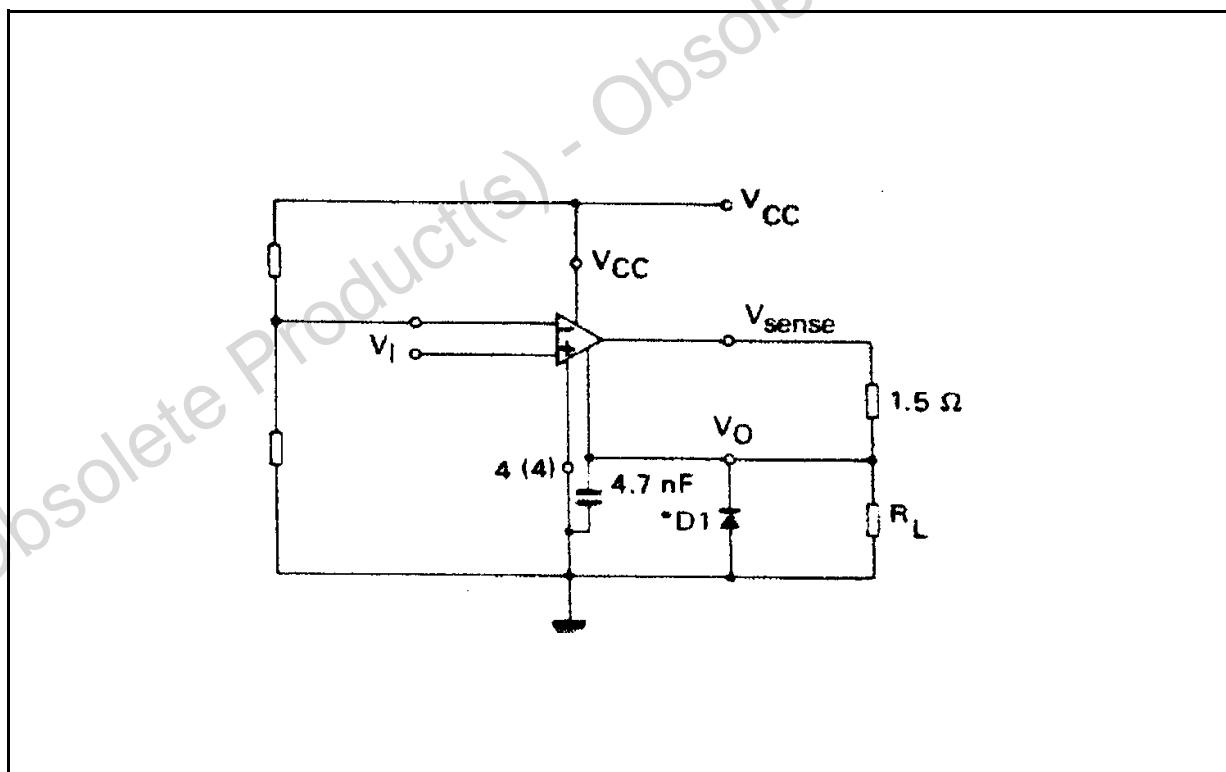

Figure 11: Output Current Extension (5A)

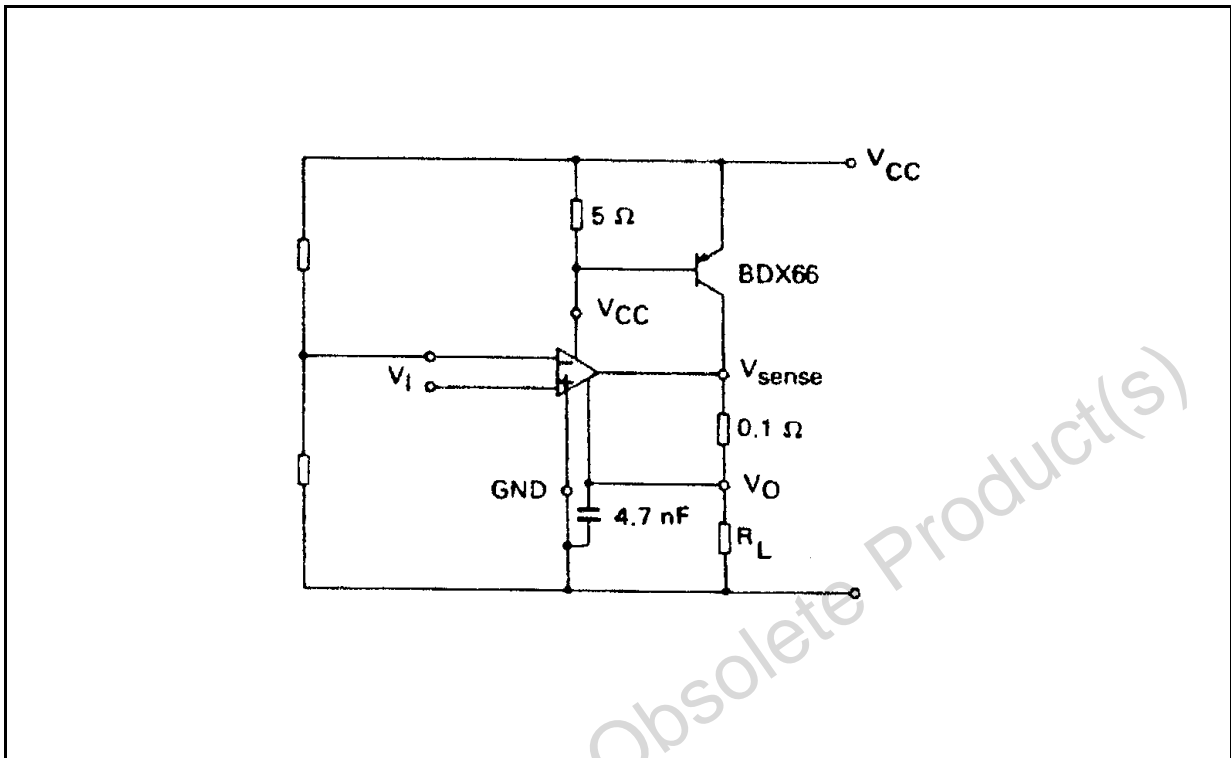

Figure 12: Driving Low Impedance Relays ($I_o = 300\text{mA}$)

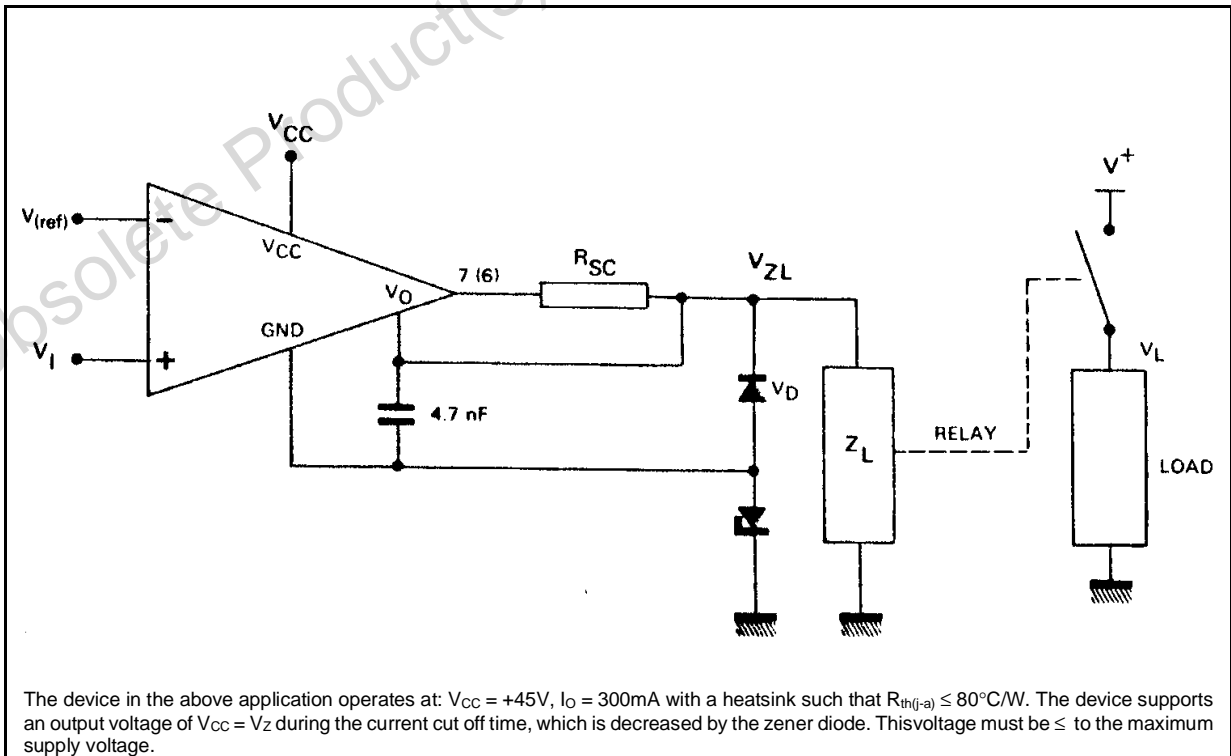
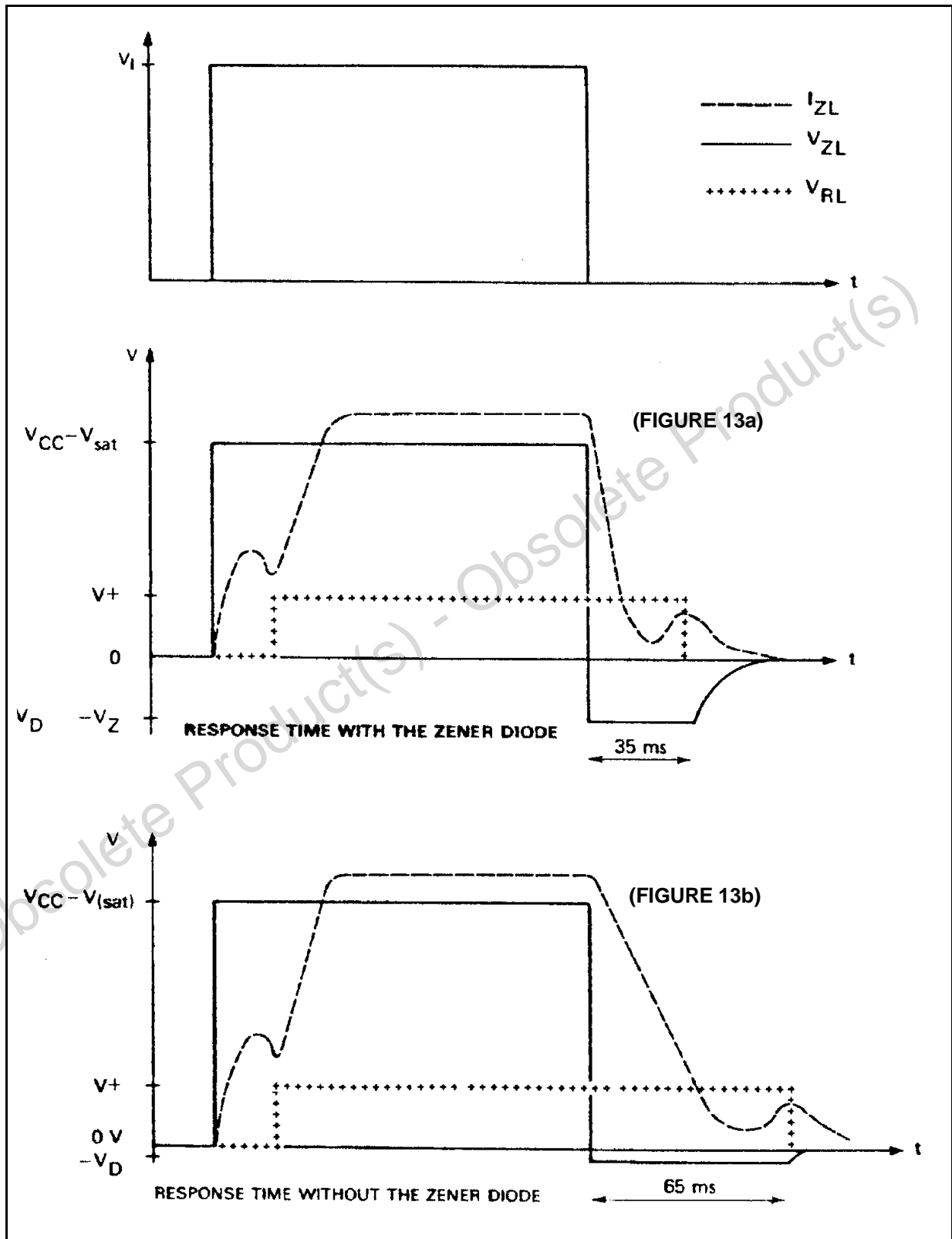
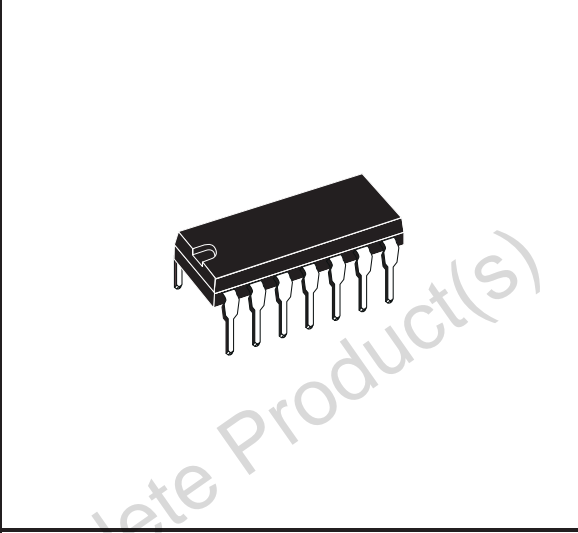

Figure 13: Waveforms



DIM.	mm			inch		
	MIN.	TYP.	MAX.	MIN.	TYP.	MAX.
a1	0.51			0.020		
B	1.39		1.65	0.055		0.065
b		0.5			0.020	
b1		0.25			0.010	
D			20			0.787
E		8.5			0.335	
e		2.54			0.100	
e3		15.24			0.600	
F			7.1			0.280
I			5.1			0.201
L		3.3			0.130	
Z	1.27		2.54	0.050		0.100

OUTLINE AND MECHANICAL DATA



DIP14

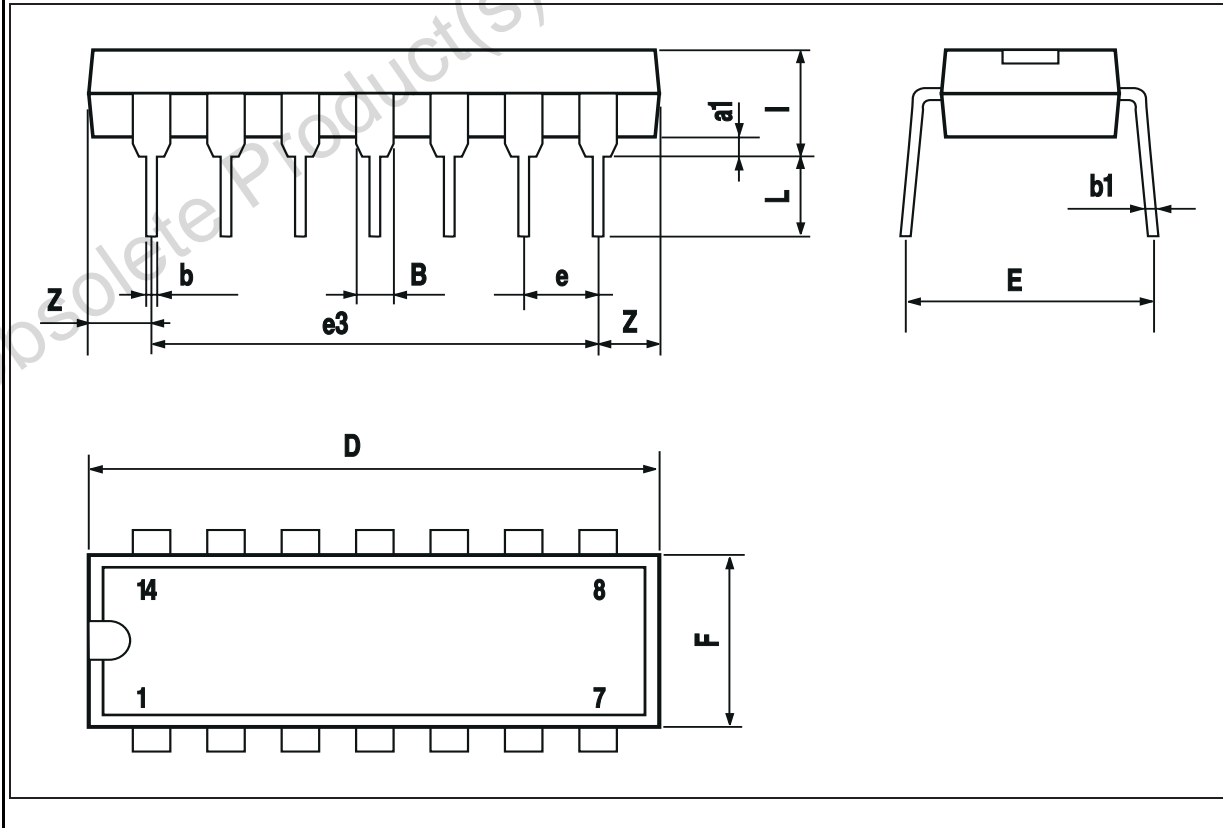

TDE1747 - TDF1747

DIM.	mm			inch		
	MIN.	TYP.	MAX.	MIN.	TYP.	MAX.
A		3.32			0.131	
a1	0.51			0.020		
B	1.15		1.65	0.045		0.065
b	0.356		0.55	0.014		0.022
b1	0.204		0.304	0.008		0.012
D			10.92			0.430
E	7.95		9.75	0.313		0.384
e		2.54			0.100	
e3		7.62			0.300	
e4		7.62			0.300	
F			6.6			0.260
I			5.08			0.200
L	3.18		3.81	0.125		0.150
Z			1.52			0.060

OUTLINE AND MECHANICAL DATA

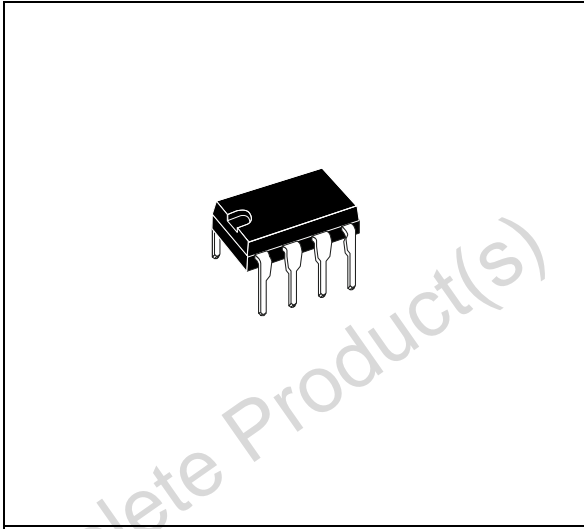

Minidip

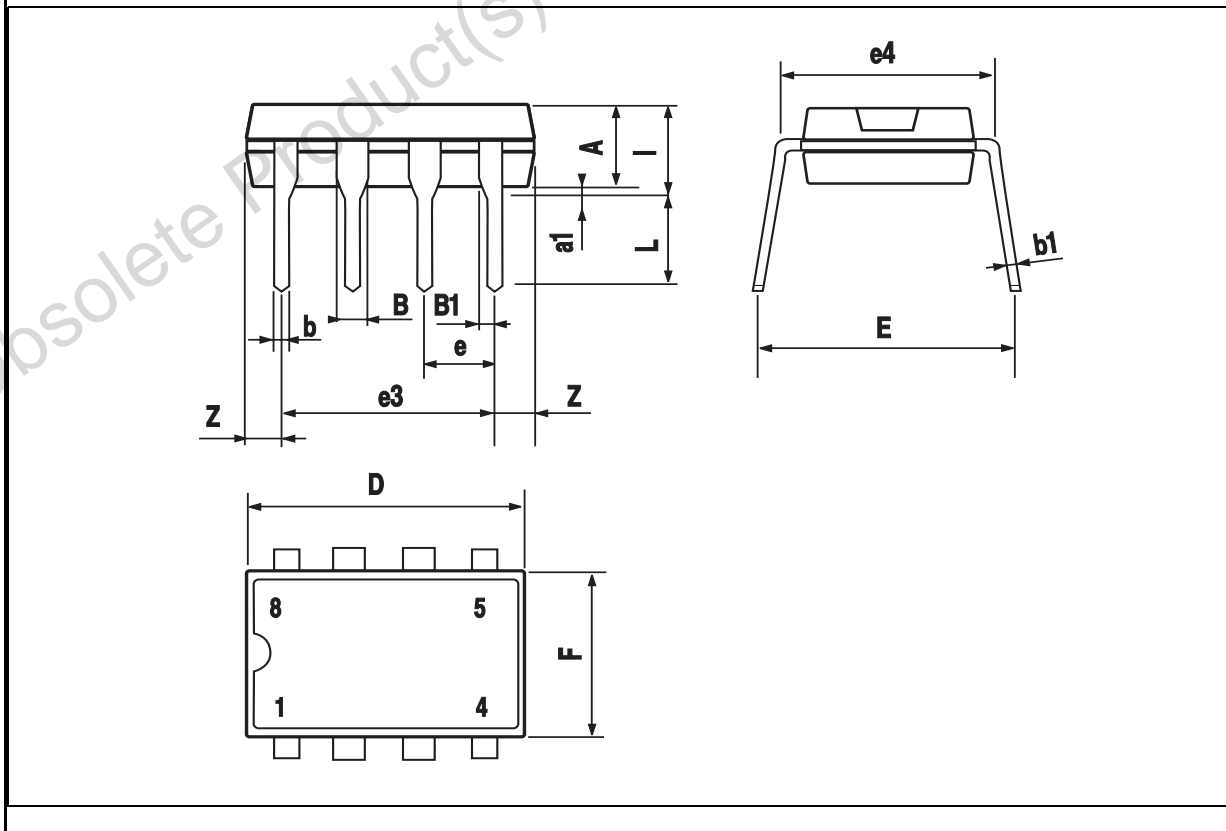

Obsolete Product(s) - Obsolete Product(s)

Information furnished is believed to be accurate and reliable. However, STMicroelectronics assumes no responsibility for the consequences of use of such information nor for any infringement of patents or other rights of third parties which may result from its use. No license is granted by implication or otherwise under any patent or patent rights of STMicroelectronics. Specifications mentioned in this publication are subject to change without notice. This publication supersedes and replaces all information previously supplied. STMicroelectronics products are not authorized for use as critical components in life support devices or systems without express written approval of STMicroelectronics.

The ST logo is a registered trademark of STMicroelectronics.
All other names are the property of their respective owners

© 2003 STMicroelectronics - All rights reserved

STMicroelectronics GROUP OF COMPANIES



Australia – Belgium - Brazil - Canada - China – Czech Republic - Finland - France - Germany - Hong Kong - India - Israel - Italy - Japan - Malaysia - Malta - Morocco - Singapore - Spain - Sweden - Switzerland - United Kingdom - United States

www.st.com



Looking for pricing, stock, or lifecycle information?

Click below to explore more details on WIN SOURCE:

-  [View TDE1747DP](#) on WIN SOURCE
-  [STMicroelectronics](#) Information

Optimize Your Supply Chain with WIN SOURCE Solutions

-  Global Sourcing Solution
-  Obsolete Management
-  Cost Control Management
-  Shortage Management
-  Alternative Solution
-  Excess Inventory Management