



**THE DATASHEET OF  
TLVH431BQDBVRQ1**



## LOW-VOLTAGE ADJUSTABLE PRECISION SHUNT REGULATORS

 Check for Samples: [TLVH431A-Q1](#), [TLVH431B-Q1](#)

### FEATURES

- Qualified for Automotive Applications
- Low-Voltage Operation: Down to 1.24 V
- Reference Voltage Tolerances at 25°C
  - 0.5% for B Grade
  - 1% for A Grade
- Adjustable Output Voltage,  $V_O = V_{REF}$  to 18 V
- Wide Operating Cathode Current Range: 100  $\mu$ A to 70 mA
- 0.25- $\Omega$  Typical Output Impedance
- –40°C to 125°C Specifications

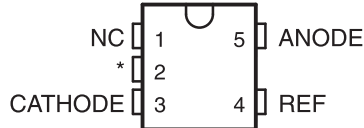
**DBV (SOT-23-5) PACKAGE  
(TOP VIEW)**

NC – No internal connection

\* Pin 2 is attached to Substrate and must be connected to ANODE or left open.

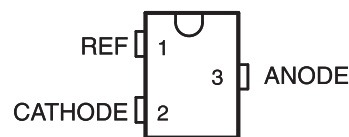
**DBZ (SOT-23-3) PACKAGE  
(TOP VIEW)**

### DESCRIPTION/ORDERING INFORMATION

The TLVH431 devices are low-voltage 3-terminal adjustable voltage references, with thermal stability specified over the automotive temperature range. Output voltage can be set to any value between  $V_{REF}$  (1.24 V) and 18 V with two external resistors (see [Figure 2](#)). These devices operate from a lower voltage (1.24 V) than the widely used TL431 and TL1431 shunt-regulator references.

When used with an optocoupler, the TLVH431 devices are ideal voltage reference in isolated feedback circuits for 3-V to 3.3-V switching-mode power supplies. They have a typical output impedance of 0.25  $\Omega$ . Active output circuitry provides a very sharp turn-on characteristic, making the TLVH431 an excellent replacement for low-voltage Zener diodes in many applications, including on-board regulation and adjustable power supplies.

#### ORDERING INFORMATION<sup>(1)</sup>

$T_A$	$V_{REF}$ TOLERANCE	PACKAGE <sup>(2)</sup>		ORDERABLE PART NUMBER	TOP-SIDE MARKING
–40°C to 125°C	0.5%	SOT-23-5 – DBV	Reel of 3000	TLVH431BQDBVRQ1	VOPQ
	0.5%	SOT-23-3 - DBZ	Reel of 3000	TLVH431BQDBZRQ1	VPIQ
	1%	SOT-23-5 – DBV	Reel of 3000	TLVH431AQDBVRQ1	VOOQ

(1) For the most current package and ordering information, see the Package Option Addendum at the end of this document, or see the TI web site at [www.ti.com](http://www.ti.com).

(2) Package drawings, thermal data, and symbolization are available at [www.ti.com/packaging](http://www.ti.com/packaging).



Please be aware that an important notice concerning availability, standard warranty, and use in critical applications of Texas Instruments semiconductor products and disclaimers thereto appears at the end of this data sheet.

### LOGIC BLOCK DIAGRAM

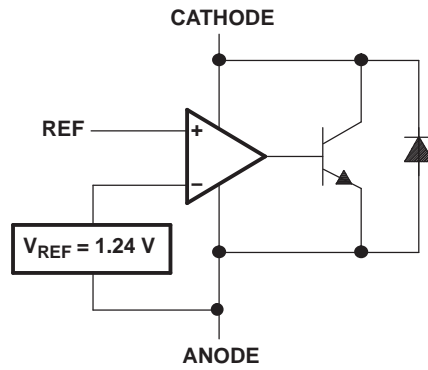

### EQUIVALENT SCHEMATIC

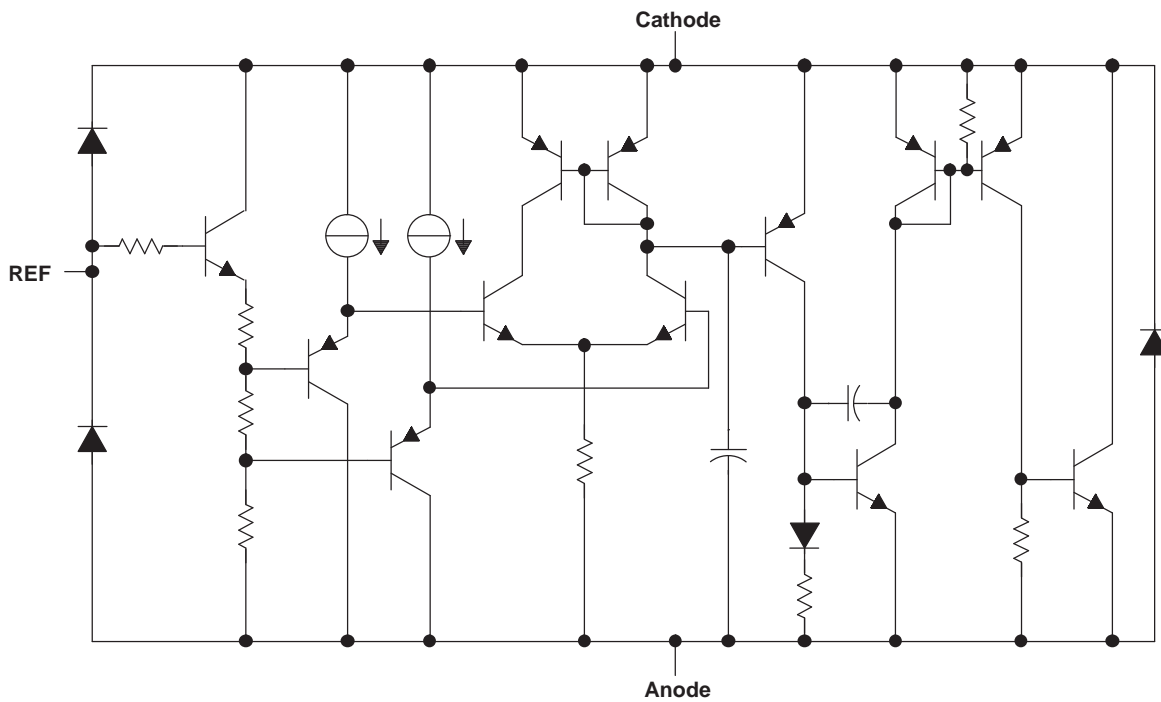

## ABSOLUTE MAXIMUM RATINGS<sup>(1)</sup>

over operating free-air temperature range (unless otherwise noted)

$V_{KA}$	Cathode voltage <sup>(2)</sup>	20 V
$I_K$	Cathode current range	–25 mA to 80 mA
$I_{ref}$	Reference current range	–0.05 mA to 3 mA
$\theta_{JA}$	Package thermal impedance <sup>(3) (4)</sup>	206°C/W
$T_J$	Operating virtual junction temperature	150°C
$T_{stg}$	Storage temperature range	–65°C to 150°C

- (1) Stresses beyond those listed under "absolute maximum ratings" may cause permanent damage to the device. These are stress ratings only, and functional operation of the device at these or any other conditions beyond those indicated under "recommended operating conditions" is not implied. Exposure to absolute-maximum-rated conditions for extended periods may affect device reliability.
- (2) Voltage values are with respect to the anode terminal, unless otherwise noted.
- (3) Maximum power dissipation is a function of  $T_J(\text{max})$ ,  $\theta_{JA}$ , and  $T_A$ . The maximum allowable power dissipation at any allowable ambient temperature is  $P_D = (T_J(\text{max}) - T_A)/\theta_{JA}$ . Operating at the absolute maximum  $T_J$  of 150°C can affect reliability.
- (4) The package thermal impedance is calculated in accordance with JESD 51-7.

## RECOMMENDED OPERATING CONDITIONS

		MIN	MAX	UNIT
$V_{KA}$	Cathode voltage	$V_{REF}$	18	V
$I_K$	Cathode current (continuous)	0.1	70	mA
$T_A$	Operating free-air temperature	–40	125	°C

## TLVH431A ELECTRICAL CHARACTERISTICS

at 25°C free-air temperature (unless otherwise noted)

PARAMETER		TEST CONDITIONS	MIN	TYP	MAX	UNIT	
V <sub>REF</sub>	Reference voltage	V <sub>K<sub>A</sub></sub> = V <sub>REF</sub> , I <sub>K</sub> = 10 mA	T <sub>A</sub> = 25°C	1.228	1.24	1.252	V
			T <sub>A</sub> = full range <sup>(1)</sup> (see Figure 1)	1.209		1.271	
V <sub>REF(dev)</sub>	V <sub>REF</sub> deviation over full temperature range <sup>(1) (2)</sup>	V <sub>K<sub>A</sub></sub> = V <sub>REF</sub> , I <sub>K</sub> = 10 mA (see Figure 1)		11	31	mV	
$\frac{\Delta V_{REF}}{\Delta V_{KA}}$	Ratio of V <sub>REF</sub> change to cathode voltage change	V <sub>K</sub> = V <sub>REF</sub> to 18 V, I <sub>K</sub> = 10 mA (see Figure 2)		-1.5	-2.7	mV/V	
I <sub>ref</sub>	Reference terminal current	I <sub>K</sub> = 10 mA, R1 = 10 kΩ, R2 = open (see Figure 2)		0.1	0.5	μA	
I <sub>ref(dev)</sub>	I <sub>ref</sub> deviation over full temperature range <sup>(1) (2)</sup>	I <sub>K</sub> = 10 mA, R1 = 10 kΩ, R2 = open (see Figure 2)		0.15	0.5	μA	
I <sub>K(min)</sub>	Minimum cathode current for regulation	V <sub>K<sub>A</sub></sub> = V <sub>REF</sub> (see Figure 1)		60	100	μA	
I <sub>K(off)</sub>	Off-state cathode current	V <sub>REF</sub> = 0, V <sub>K<sub>A</sub></sub> = 18 V (see Figure 3)		0.02	0.1	μA	
z <sub>KA</sub>	Dynamic impedance <sup>(3)</sup>	V <sub>K<sub>A</sub></sub> = V <sub>REF</sub> , f ≤ 1 kHz, I <sub>K</sub> = 0.1 mA to 70 mA (see Figure 1)		0.25	0.4	Ω	

(1) Full temperature range is -40°C to 125°C.

(2) The deviation parameters V<sub>REF(dev)</sub> and I<sub>ref(dev)</sub> are defined as the differences between the maximum and minimum values obtained over the rated temperature range. The average full-range temperature coefficient of the reference input voltage, αV<sub>REF</sub>, is defined as:

$$|\alpha V_{REF} \left( \frac{\text{ppm}}{\text{°C}} \right)| = \frac{\left( \frac{V_{REF(dev)}}{V_{REF}(T_A = 25\text{°C})} \right) \times 10^6}{\Delta T_A}$$

where ΔT<sub>A</sub> is the rated operating free-air temperature range of the device.

αV<sub>REF</sub> can be positive or negative, depending on whether minimum V<sub>REF</sub> or maximum V<sub>REF</sub>, respectively, occurs at the lower temperature.

(3) The dynamic impedance is defined as:

$$|z_{KA}| = \frac{\Delta V_{KA}}{\Delta I_K}$$

When the device is operating with two external resistors (see Figure 2), the total dynamic impedance of the circuit is defined as:

$$|z_{KA}| = \frac{\Delta V}{\Delta I} \approx |z_{KA}| \times \left( 1 + \frac{R1}{R2} \right)$$

## TLVH431B ELECTRICAL CHARACTERISTICS

at 25°C free-air temperature (unless otherwise noted)

PARAMETER		TEST CONDITIONS	MIN	TYP	MAX	UNIT	
V <sub>REF</sub>	Reference voltage	V <sub>KA</sub> = V <sub>REF</sub> , I <sub>K</sub> = 10 mA	T <sub>A</sub> = 25°C	1.234	1.24	1.246	V
			T <sub>A</sub> = full range <sup>(1)</sup> (see Figure 1)	1.221		1.265	
V <sub>REF(dev)</sub>	V <sub>REF</sub> deviation over full temperature range <sup>(1) (2)</sup>	V <sub>KA</sub> = V <sub>REF</sub> , I <sub>K</sub> = 10 mA (see Figure 1)		11	31	mV	
$\frac{\Delta V_{REF}}{\Delta V_{KA}}$	Ratio of V <sub>REF</sub> change to cathode voltage change	I <sub>K</sub> = 10 mA, V <sub>K</sub> = V <sub>REF</sub> to 18 V (see Figure 2)		-1.5	-2.7	mV/V	
I <sub>ref</sub>	Reference terminal current	I <sub>K</sub> = 10 mA, R1 = 10 kΩ, R2 = open (see Figure 2)		0.1	0.5	μA	
I <sub>ref(dev)</sub>	I <sub>ref</sub> deviation over full temperature range <sup>(1) (2)</sup>	I <sub>K</sub> = 10 mA, R1 = 10 kΩ, R2 = open (see Figure 2)		0.15	0.5	μA	
I <sub>K(min)</sub>	Minimum cathode current for regulation	V <sub>KA</sub> = V <sub>REF</sub> (see Figure 1)		60	100	μA	
I <sub>K(off)</sub>	Off-state cathode current	V <sub>REF</sub> = 0, V <sub>KA</sub> = 18 V (see Figure 3)		0.02	0.1	μA	
z <sub>KA</sub>	Dynamic impedance <sup>(3)</sup>	V <sub>KA</sub> = V <sub>REF</sub> , f ≤ 1 kHz, I <sub>K</sub> = 0.1 mA to 70 mA (see Figure 1)		0.25	0.4	Ω	

(1) Full temperature range is -40°C to 125°C.

(2) The deviation parameters V<sub>REF(dev)</sub> and I<sub>ref(dev)</sub> are defined as the differences between the maximum and minimum values obtained over the rated temperature range. The average full-range temperature coefficient of the reference input voltage, αV<sub>REF</sub>, is defined as:

$$|\alpha V_{REF} \left( \frac{\text{ppm}}{\text{°C}} \right)| = \frac{\left( \frac{V_{REF(dev)}}{V_{REF}(T_A = 25\text{°C})} \right) \times 10^6}{\Delta T_A}$$

where ΔT<sub>A</sub> is the rated operating free-air temperature range of the device.

αV<sub>REF</sub> can be positive or negative, depending on whether minimum V<sub>REF</sub> or maximum V<sub>REF</sub>, respectively, occurs at the lower temperature.

(3) The dynamic impedance is defined as:

$$|z_{KA}| = \frac{\Delta V_{KA}}{\Delta I_K}$$

When the device is operating with two external resistors (see Figure 2), the total dynamic impedance of the circuit is defined as:

$$|z_{KA}| = \frac{\Delta V}{\Delta I} \approx |z_{KA}| \times \left( 1 + \frac{R1}{R2} \right)$$

### PARAMETER MEASUREMENT INFORMATION

Operation of the device at any conditions beyond those indicated under *recommended operating conditions* is not implied.

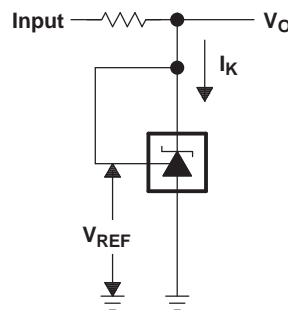

Figure 1. Test Circuit for  $V_{KA} = V_{REF}$ ,  $V_O = V_{KA} = V_{REF}$

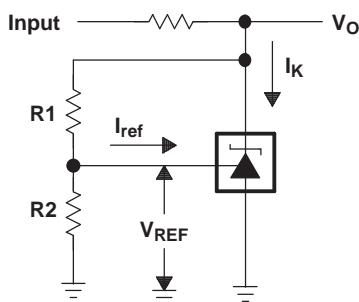

Figure 2. Test Circuit for  $V_{KA} > V_{REF}$ ,  $V_O = V_{KA} = V_{REF} \times (1 + R1/R2) + I_{ref} \times R1$

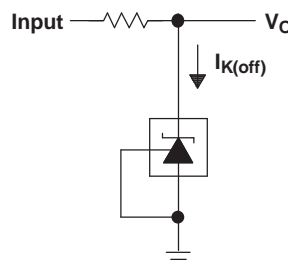

Figure 3. Test Circuit for  $I_{K(off)}$

PARAMETER MEASUREMENT INFORMATION (continued)

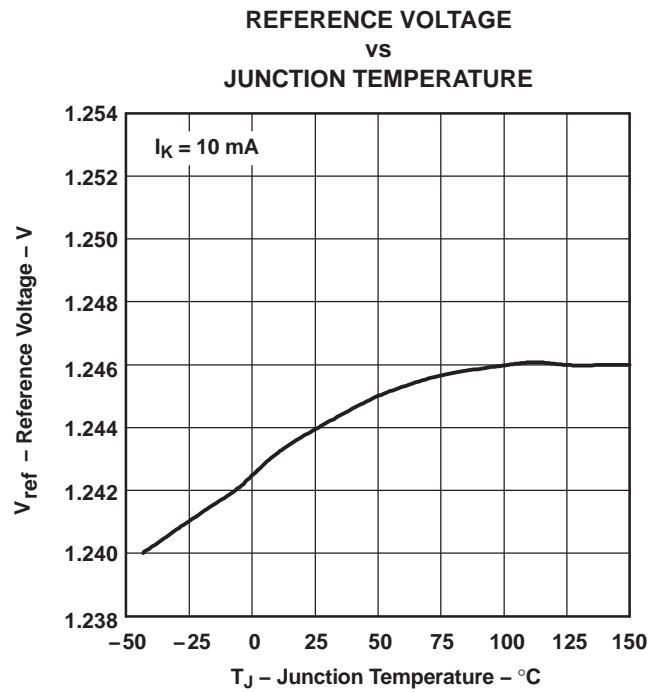

Figure 4.

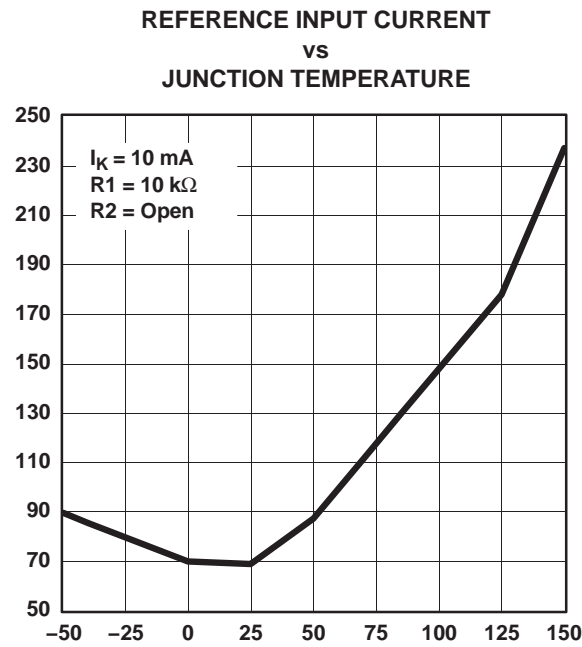

Figure 5.

PARAMETER MEASUREMENT INFORMATION (continued)

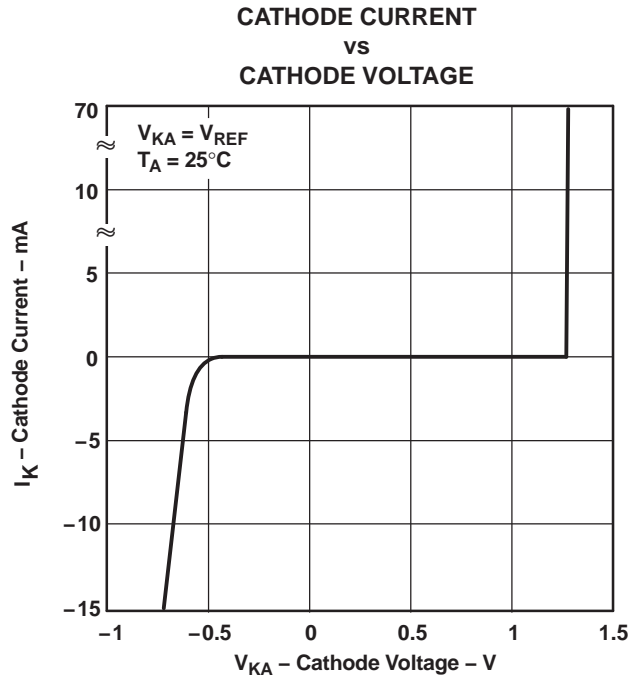

Figure 6.

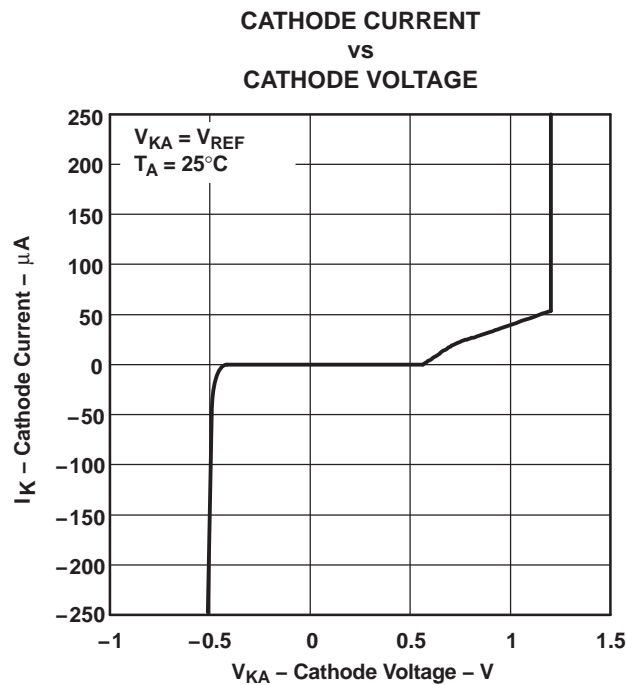

Figure 7.

PARAMETER MEASUREMENT INFORMATION (continued)

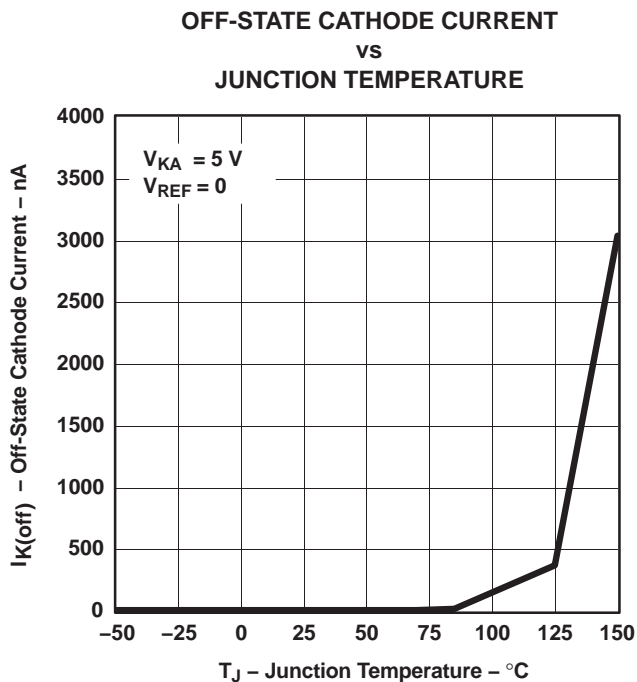

Figure 8.

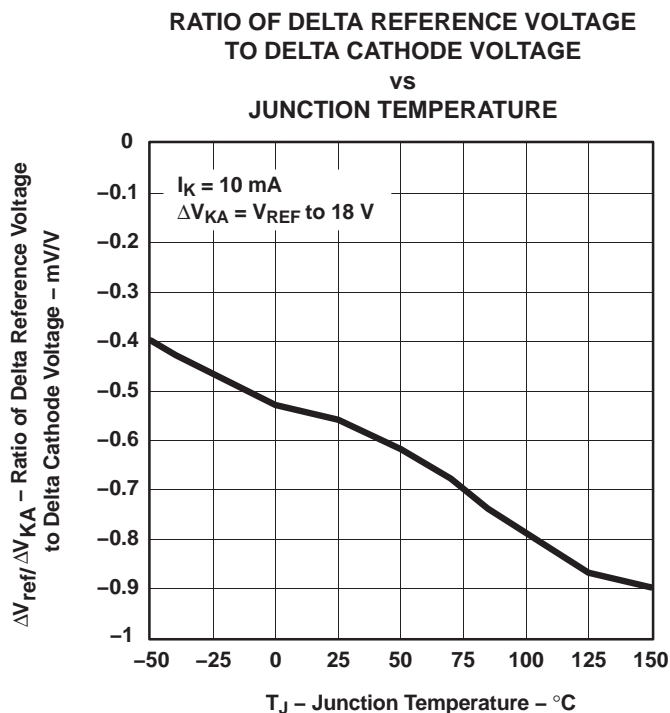
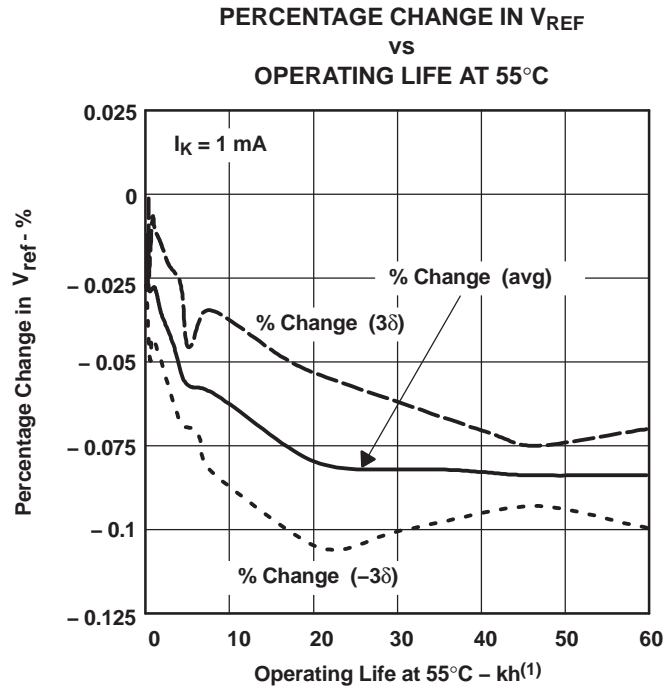

Figure 9.

PARAMETER MEASUREMENT INFORMATION (continued)



(1) Extrapolated from life-test data taken at 125°C; the activation energy assumed is 0.7 eV.

Figure 10.

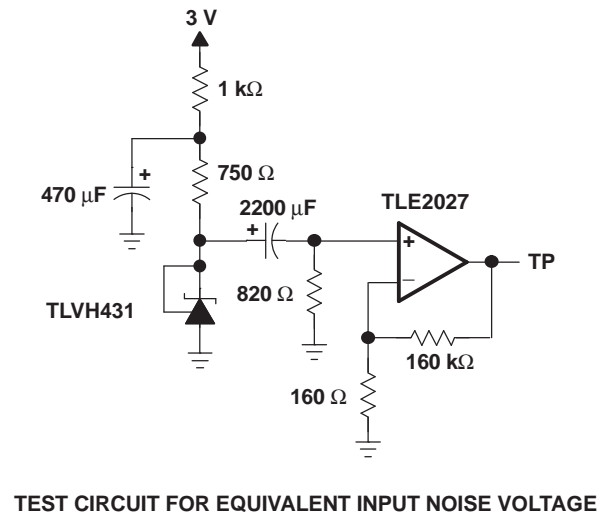
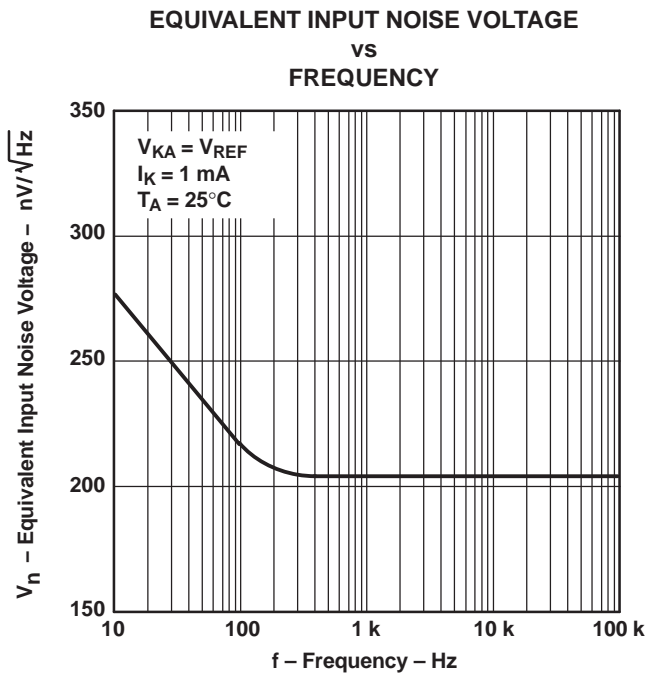
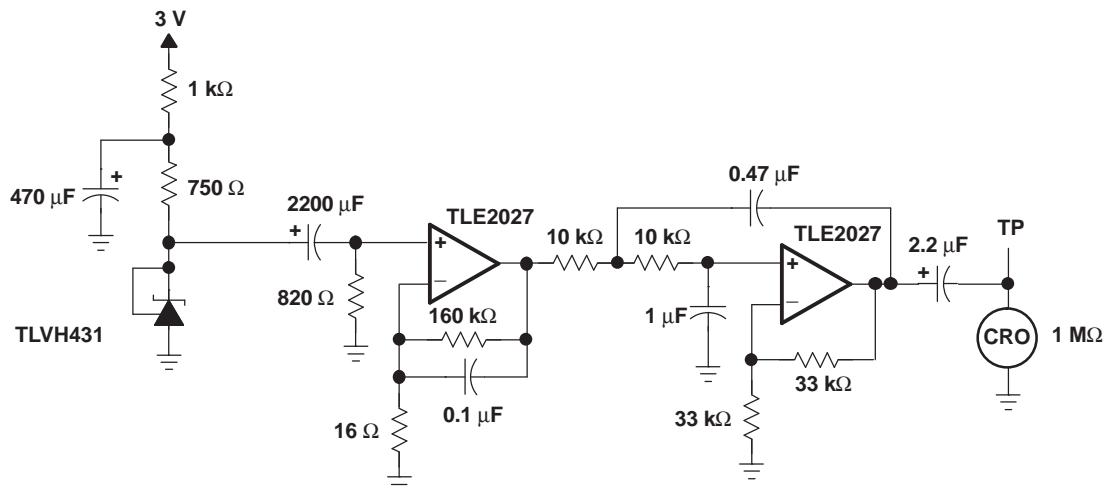
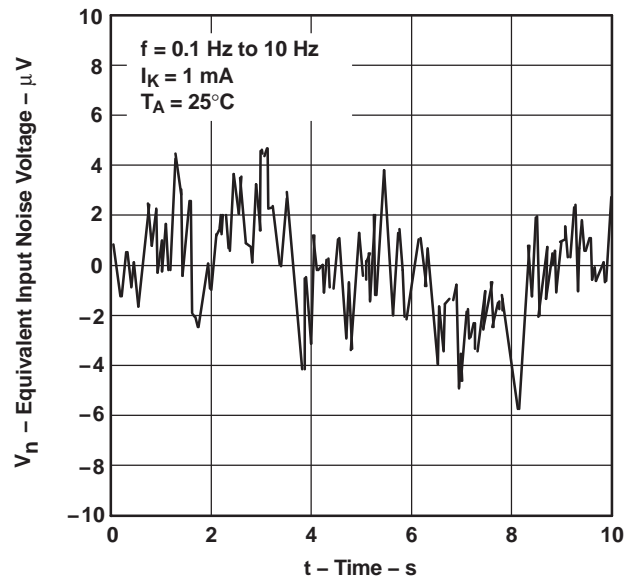

Figure 11.

PARAMETER MEASUREMENT INFORMATION (continued)

EQUIVALENT INPUT NOISE VOLTAGE  
OVER A 10-S PERIOD



TEST CIRCUIT FOR 0.1-Hz TO 10-Hz EQUIVALENT NOISE VOLTAGE

Figure 12.

PARAMETER MEASUREMENT INFORMATION (continued)

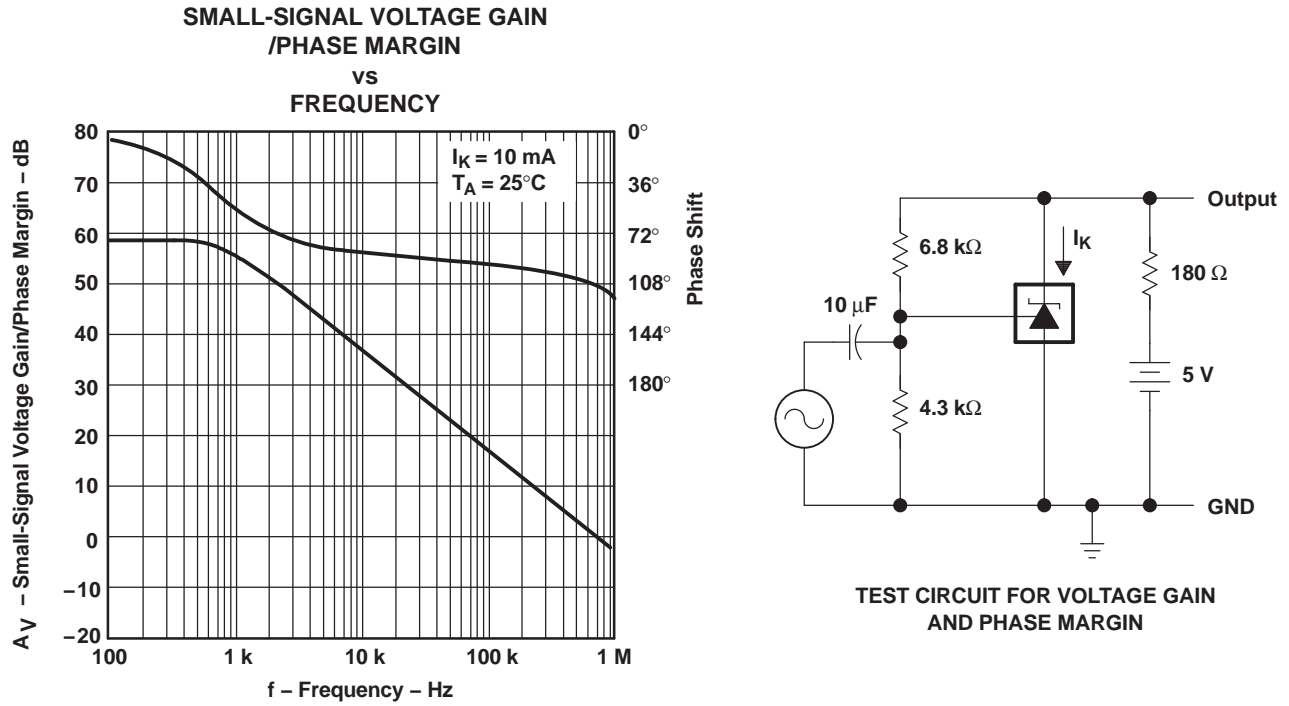

Figure 13.

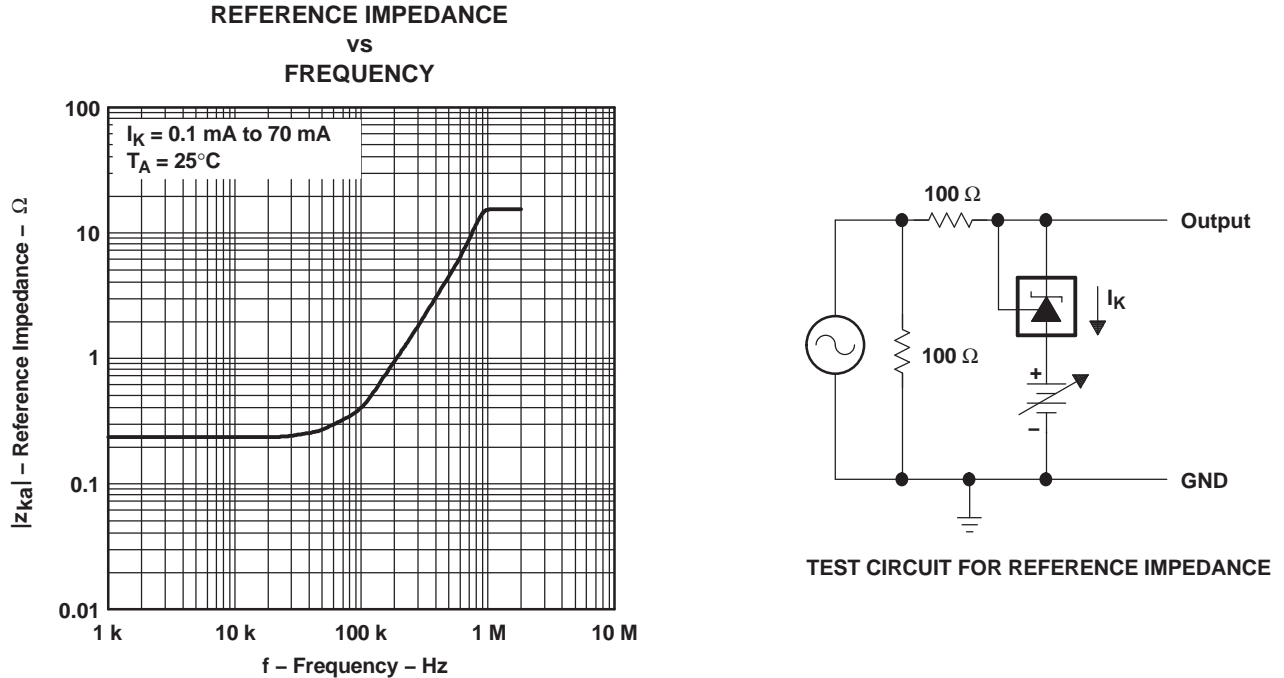

Figure 14.

PARAMETER MEASUREMENT INFORMATION (continued)

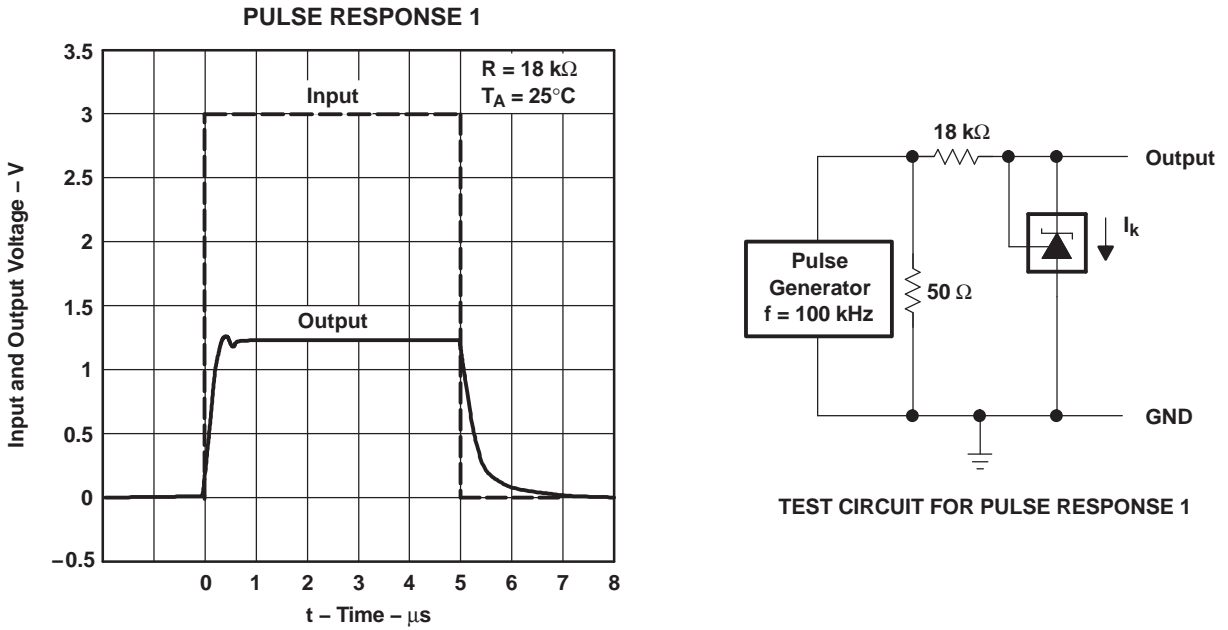

Figure 15.

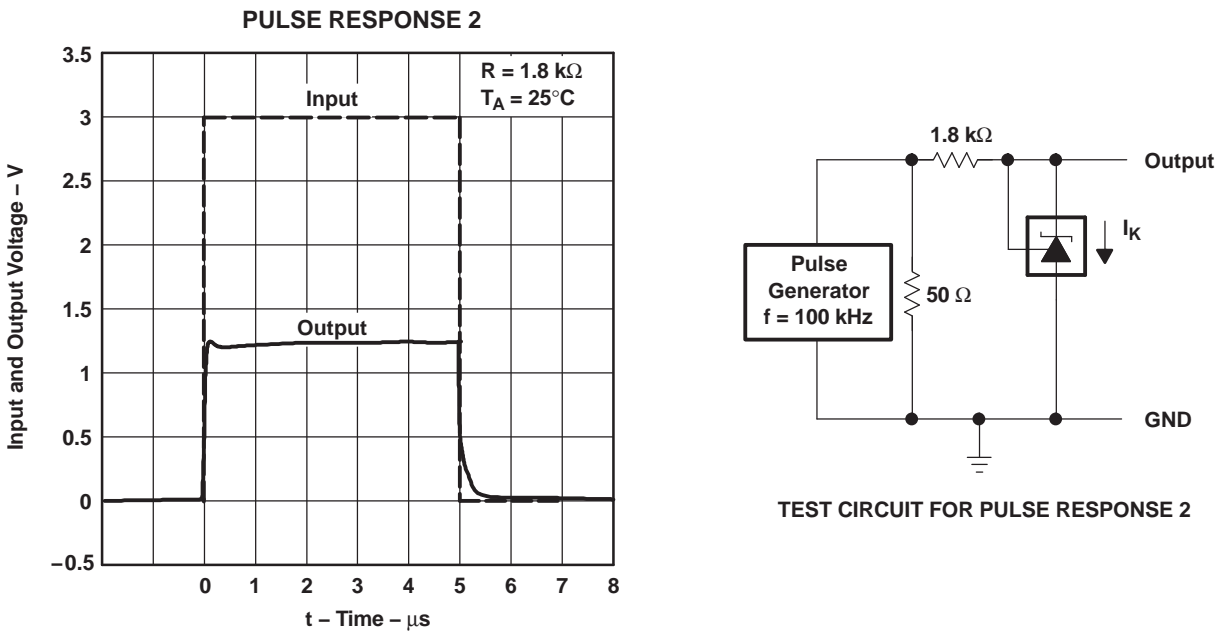

Figure 16.

PARAMETER MEASUREMENT INFORMATION (continued)

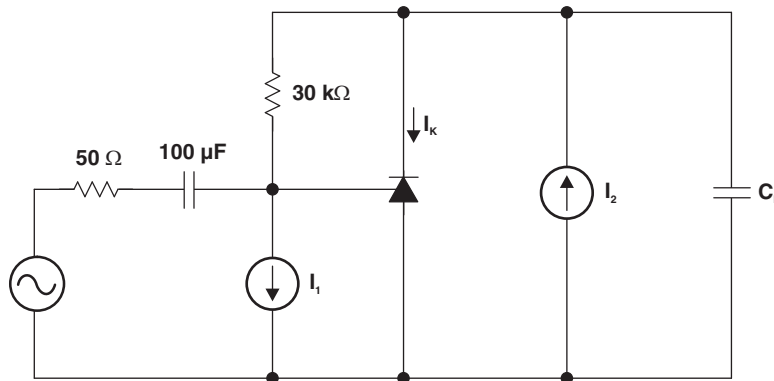

Figure 17. Phase Margin Test Circuit

PHASE MARGIN vs CAPACITIVE LOAD

$V_{ka} = V_{REF} (1.25 \text{ V})$ ,  $T_A = 25^\circ\text{C}$

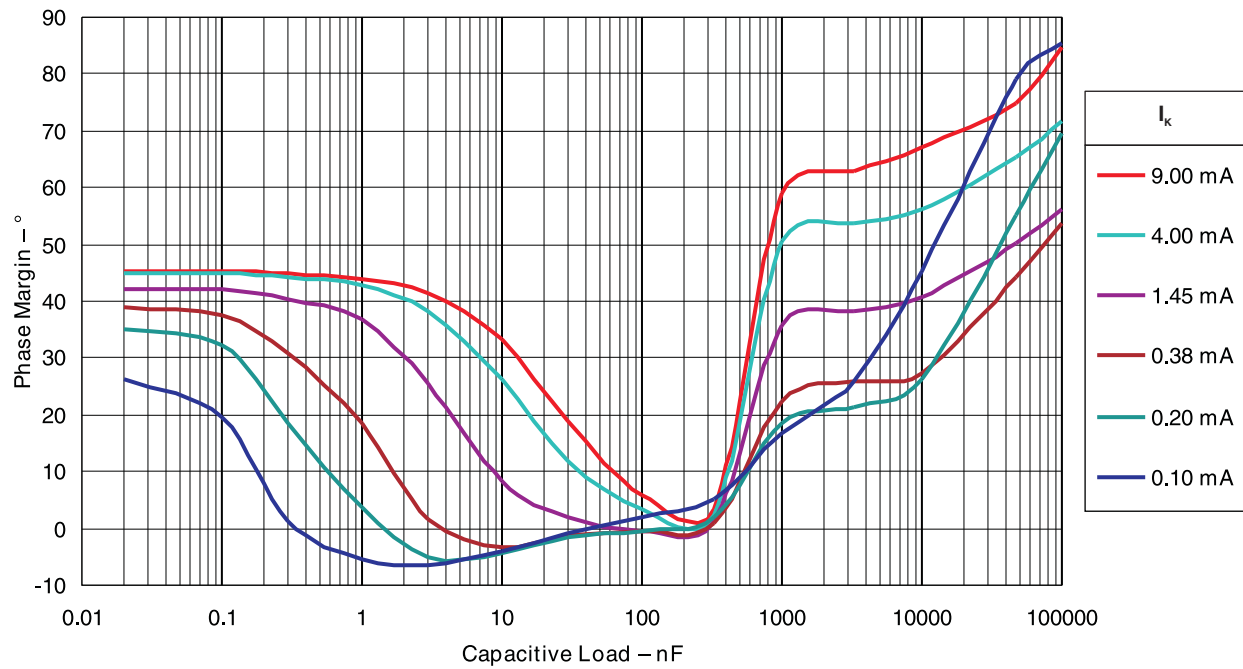

Figure 18.

PARAMETER MEASUREMENT INFORMATION (continued)

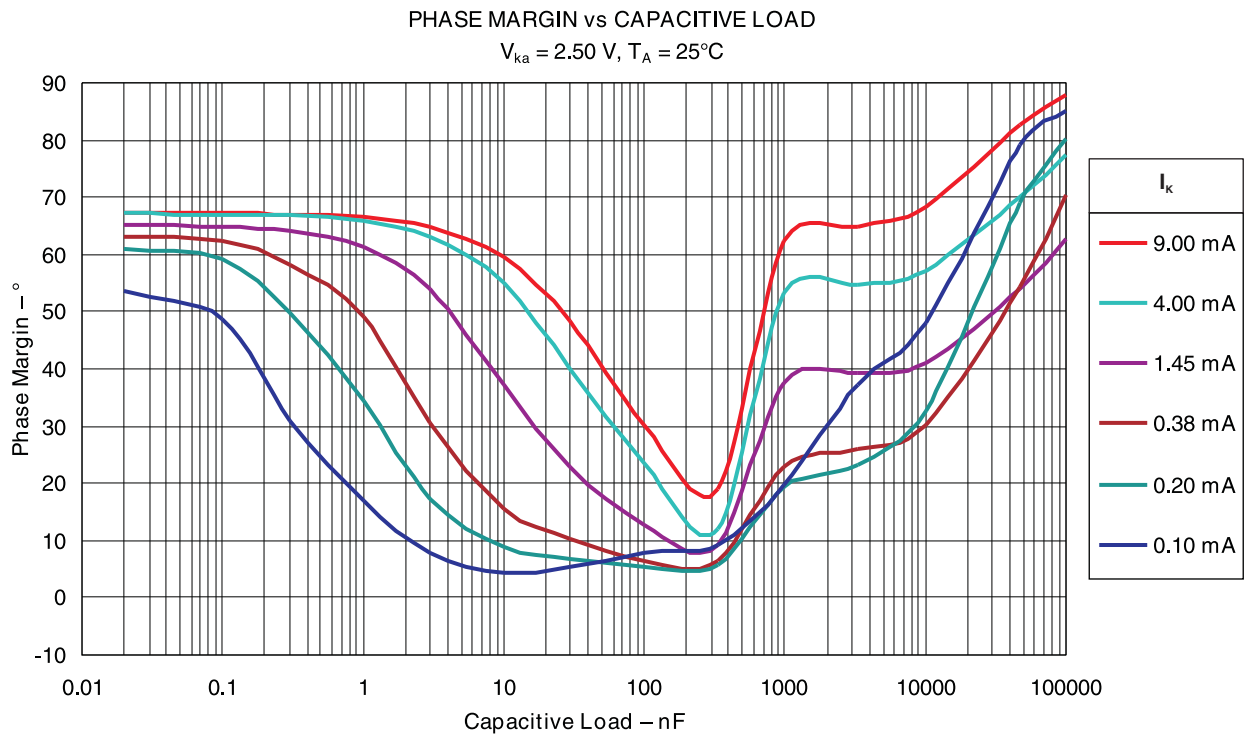

Figure 19.

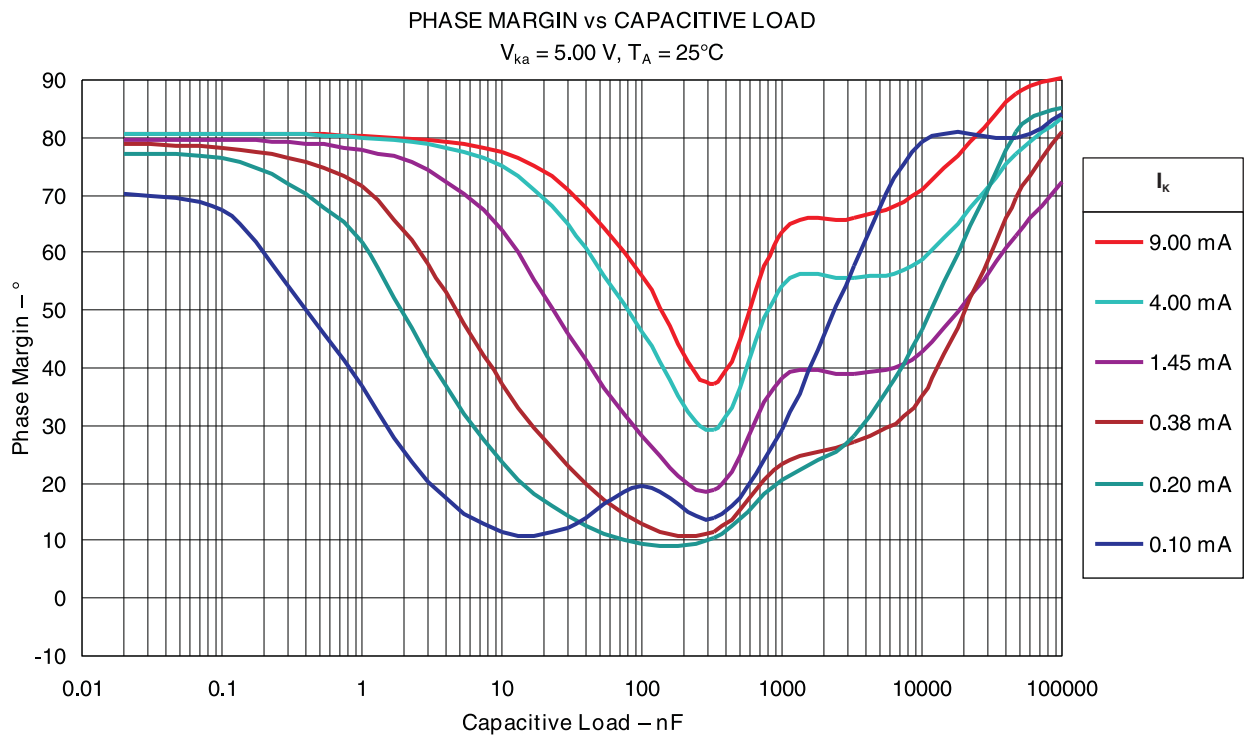

Figure 20.

APPLICATION INFORMATION

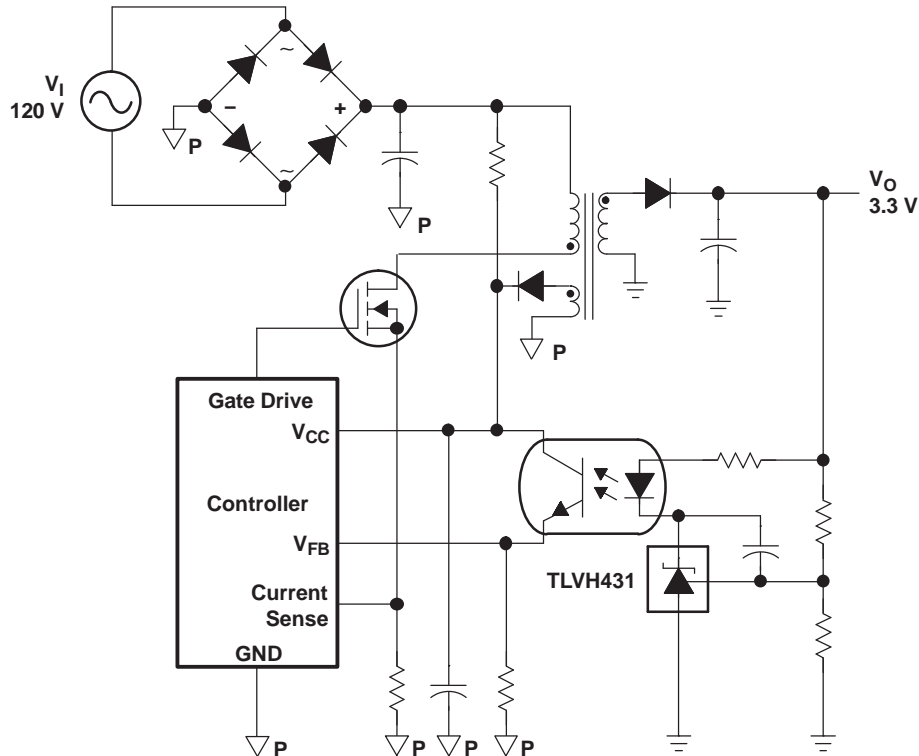

Figure 21. Flyback With Isolation Using TLVH431 as Voltage Reference and Error Amplifier

Figure 21 shows the TLVH431 used in a 3.3-V isolated flyback supply. Output voltage  $V_O$  can be as low as reference voltage  $V_{REF}$  (1.24 V). The output of the regulator plus the forward voltage drop of the optocoupler LED ( $1.24 + 1.4 = 2.64$  V) determine the minimum voltage that can be regulated in an isolated supply configuration. Regulated voltage as low as 2.7 Vdc is possible in the topology shown in Figure 21.

**PACKAGING INFORMATION**

Orderable Device	Status (1)	Package Type	Package Drawing	Pins	Package Qty	Eco Plan (2)	Lead/Ball Finish	MSL Peak Temp (3)	Op Temp (°C)	Top-Side Markings (4)	Samples
TLVH431AQDBVRQ1	ACTIVE	SOT-23	DBV	5	3000	Green (RoHS & no Sb/Br)	CU NIPDAU	Level-1-260C-UNLIM	-40 to 125	VOOQ	<a href="#">Samples</a>
TLVH431BQDBVRQ1	ACTIVE	SOT-23	DBV	5	3000	Green (RoHS & no Sb/Br)	CU NIPDAU	Level-1-260C-UNLIM	-40 to 125	VOPQ	<a href="#">Samples</a>
TLVH431BQDBZRQ1	ACTIVE	SOT-23	DBZ	3	3000	Green (RoHS & no Sb/Br)	CU NIPDAU	Level-1-260C-UNLIM	-40 to 125	VPIQ	<a href="#">Samples</a>

(1) The marketing status values are defined as follows:

**ACTIVE:** Product device recommended for new designs.

**LIFEBUY:** TI has announced that the device will be discontinued, and a lifetime-buy period is in effect.

**NRND:** Not recommended for new designs. Device is in production to support existing customers, but TI does not recommend using this part in a new design.

**PREVIEW:** Device has been announced but is not in production. Samples may or may not be available.

**OBsolete:** TI has discontinued the production of the device.

(2) Eco Plan - The planned eco-friendly classification: Pb-Free (RoHS), Pb-Free (RoHS Exempt), or Green (RoHS & no Sb/Br) - please check <http://www.ti.com/productcontent> for the latest availability information and additional product content details.

**TBD:** The Pb-Free/Green conversion plan has not been defined.

**Pb-Free (RoHS):** TI's terms "Lead-Free" or "Pb-Free" mean semiconductor products that are compatible with the current RoHS requirements for all 6 substances, including the requirement that lead not exceed 0.1% by weight in homogeneous materials. Where designed to be soldered at high temperatures, TI Pb-Free products are suitable for use in specified lead-free processes.

**Pb-Free (RoHS Exempt):** This component has a RoHS exemption for either 1) lead-based flip-chip solder bumps used between the die and package, or 2) lead-based die adhesive used between the die and leadframe. The component is otherwise considered Pb-Free (RoHS compatible) as defined above.

**Green (RoHS & no Sb/Br):** TI defines "Green" to mean Pb-Free (RoHS compatible), and free of Bromine (Br) and Antimony (Sb) based flame retardants (Br or Sb do not exceed 0.1% by weight in homogeneous material)

(3) MSL, Peak Temp. -- The Moisture Sensitivity Level rating according to the JEDEC industry standard classifications, and peak solder temperature.

(4) Multiple Top-Side Markings will be inside parentheses. Only one Top-Side Marking contained in parentheses and separated by a "~" will appear on a device. If a line is indented then it is a continuation of the previous line and the two combined represent the entire Top-Side Marking for that device.

**Important Information and Disclaimer:** The information provided on this page represents TI's knowledge and belief as of the date that it is provided. TI bases its knowledge and belief on information provided by third parties, and makes no representation or warranty as to the accuracy of such information. Efforts are underway to better integrate information from third parties. TI has taken and continues to take reasonable steps to provide representative and accurate information but may not have conducted destructive testing or chemical analysis on incoming materials and chemicals. TI and TI suppliers consider certain information to be proprietary, and thus CAS numbers and other limited information may not be available for release.

In no event shall TI's liability arising out of such information exceed the total purchase price of the TI part(s) at issue in this document sold by TI to Customer on an annual basis.

**OTHER QUALIFIED VERSIONS OF TLVH431A-Q1, TLVH431B-Q1 :**

- Catalog: [TLVH431A](#), [TLVH431B](#)

## NOTE: Qualified Version Definitions:

- Catalog - TI's standard catalog product

**TAPE AND REEL INFORMATION**

**QUADRANT ASSIGNMENTS FOR PIN 1 ORIENTATION IN TAPE**

\*All dimensions are nominal

Device	Package Type	Package Drawing	Pins	SPQ	Reel Diameter (mm)	Reel Width W1 (mm)	A0 (mm)	B0 (mm)	K0 (mm)	P1 (mm)	W (mm)	Pin1 Quadrant
TLVH431AQDBVRQ1	SOT-23	DBV	5	3000	179.0	8.4	3.2	3.2	1.4	4.0	8.0	Q3
TLVH431BQDBVRQ1	SOT-23	DBV	5	3000	179.0	8.4	3.2	3.2	1.4	4.0	8.0	Q3
TLVH431BQDBZRQ1	SOT-23	DBZ	3	3000	179.0	8.4	3.15	2.95	1.22	4.0	8.0	Q3

**TAPE AND REEL BOX DIMENSIONS**

\*All dimensions are nominal

Device	Package Type	Package Drawing	Pins	SPQ	Length (mm)	Width (mm)	Height (mm)
TLVH431AQDBVRQ1	SOT-23	DBV	5	3000	203.0	203.0	35.0
TLVH431BQDBVRQ1	SOT-23	DBV	5	3000	203.0	203.0	35.0
TLVH431BQDBZRQ1	SOT-23	DBZ	3	3000	203.0	203.0	35.0





# EXAMPLE STENCIL DESIGN

DBV0005A

SOT-23 - 1.45 mm max height

SMALL OUTLINE TRANSISTOR



SOLDER PASTE EXAMPLE  
BASED ON 0.125 mm THICK STENCIL  
SCALE:15X

4214839/D 11/2018

NOTES: (continued)

7. Laser cutting apertures with trapezoidal walls and rounded corners may offer better paste release. IPC-7525 may have alternate design recommendations.
8. Board assembly site may have different recommendations for stencil design.

## GENERIC PACKAGE VIEW

**DBZ 3**

**SOT-23 - 1.12 mm max height**

SMALL OUTLINE TRANSISTOR



Images above are just a representation of the package family, actual package may vary.  
Refer to the product data sheet for package details.

4203227/C



# EXAMPLE BOARD LAYOUT

DBZ0003A

SOT-23 - 1.12 mm max height

SMALL OUTLINE TRANSISTOR

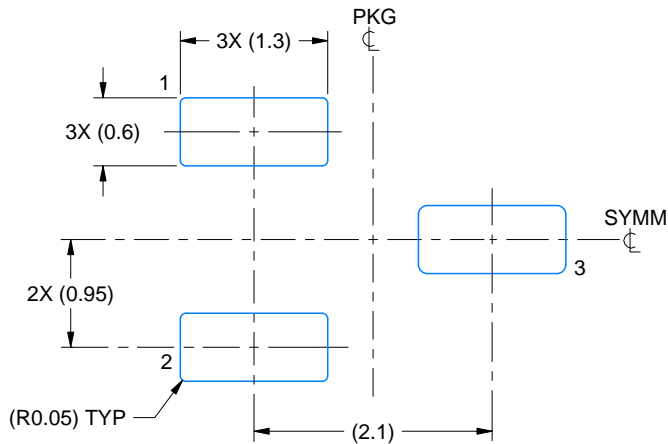

LAND PATTERN EXAMPLE  
SCALE:15X



SOLDER MASK DETAILS

4214838/C 04/2017

NOTES: (continued)

- 4. Publication IPC-7351 may have alternate designs.
- 5. Solder mask tolerances between and around signal pads can vary based on board fabrication site.

# EXAMPLE STENCIL DESIGN

DBZ0003A

SOT-23 - 1.12 mm max height

SMALL OUTLINE TRANSISTOR



SOLDER PASTE EXAMPLE  
BASED ON 0.125 THICK STENCIL  
SCALE:15X

4214838/C 04/2017

NOTES: (continued)

6. Laser cutting apertures with trapezoidal walls and rounded corners may offer better paste release. IPC-7525 may have alternate design recommendations.
7. Board assembly site may have different recommendations for stencil design.

## IMPORTANT NOTICE AND DISCLAIMER

TI PROVIDES TECHNICAL AND RELIABILITY DATA (INCLUDING DATASHEETS), DESIGN RESOURCES (INCLUDING REFERENCE DESIGNS), APPLICATION OR OTHER DESIGN ADVICE, WEB TOOLS, SAFETY INFORMATION, AND OTHER RESOURCES "AS IS" AND WITH ALL FAULTS, AND DISCLAIMS ALL WARRANTIES, EXPRESS AND IMPLIED, INCLUDING WITHOUT LIMITATION ANY IMPLIED WARRANTIES OF MERCHANTABILITY, FITNESS FOR A PARTICULAR PURPOSE OR NON-INFRINGEMENT OF THIRD PARTY INTELLECTUAL PROPERTY RIGHTS.

These resources are intended for skilled developers designing with TI products. You are solely responsible for (1) selecting the appropriate TI products for your application, (2) designing, validating and testing your application, and (3) ensuring your application meets applicable standards, and any other safety, security, or other requirements. These resources are subject to change without notice. TI grants you permission to use these resources only for development of an application that uses the TI products described in the resource. Other reproduction and display of these resources is prohibited. No license is granted to any other TI intellectual property right or to any third party intellectual property right. TI disclaims responsibility for, and you will fully indemnify TI and its representatives against, any claims, damages, costs, losses, and liabilities arising out of your use of these resources.

TI's products are provided subject to TI's Terms of Sale ([www.ti.com/legal/termsofsale.html](http://www.ti.com/legal/termsofsale.html)) or other applicable terms available either on [ti.com](http://ti.com) or provided in conjunction with such TI products. TI's provision of these resources does not expand or otherwise alter TI's applicable warranties or warranty disclaimers for TI products.

Mailing Address: Texas Instruments, Post Office Box 655303, Dallas, Texas 75265  
Copyright © 2019, Texas Instruments Incorporated

## Looking for pricing, stock, or lifecycle information?

Click below to explore more details on WIN SOURCE:

 [View TLVH431BQDBVRQ1 on WIN SOURCE](#)

 [Texas Instruments](#) Information

## Optimize Your Supply Chain with WIN SOURCE Solutions

-  Global Sourcing Solution
-  Obsolete Management
-  Cost Control Management
-  Shortage Management
-  Alternative Solution
-  Excess Inventory Management