



**THE DATASHEET OF
LT1123CZ#PBF**



FEATURES

- Extremely Low Dropout
- Low Cost
- Fixed 5V Output, Trimmed to $\pm 1\%$
- 700 μ A Quiescent Current
- 1mV Line Regulation
- 5mV Load Regulation
- Thermal Limit
- 4A Output Current Guaranteed
- Available in a 3-Pin TO-92 Package

DESCRIPTION

The LT[®]1123 is a 3-pin bipolar device designed to be used in conjunction with a discrete PNP power transistor to form an inexpensive low dropout regulator. The LT1123 consists of a trimmed bandgap reference, error amplifier, and a driver circuit capable of sinking up to 125mA from the base of the external PNP pass transistor. The LT1123 is designed to provide a fixed output voltage of 5V.

The drive pin of the device can pull down to 2V at 125mA (1.4V at 10mA). This allows a resistor to be used to reduce the base drive available to the PNP and minimize the power dissipation in the LT1123. The drive current of the LT1123 is folded back as the feedback pin approaches ground to further limit the available drive current under short-circuit conditions.

Total quiescent current for the LT1123 is only 700 μ A. The device is available in a low cost TO-92 package.

LT, LTC and LT are registered trademarks of Linear Technology Corporation. All other trademarks are the property of their respective owners.

TYPICAL APPLICATION

5V Low Dropout Regulator

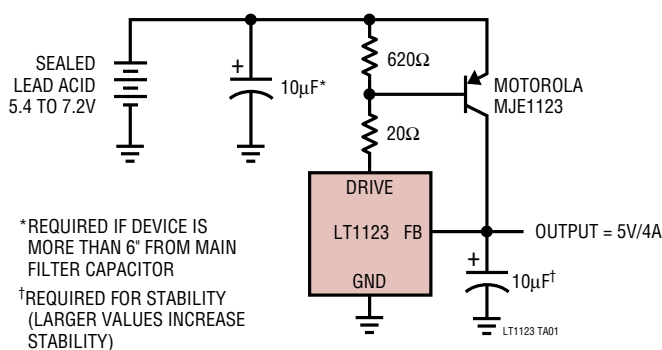

Dropout Voltage

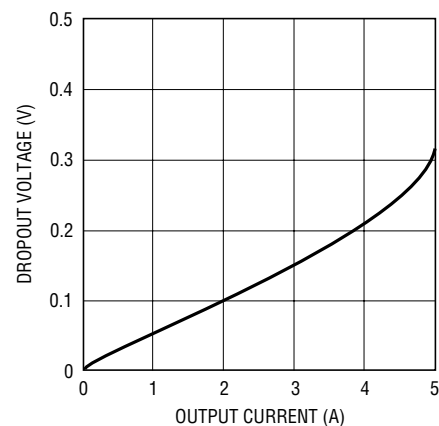

ABSOLUTE MAXIMUM RATINGS (Note 1)

Drive Pin Voltage (V_{DRIVE} to Ground)	30V	Storage Temperature Range	-65°C to 150°C
Feedback Pin Voltage (V_{FB} to Ground)	30V	Lead Temperature (Soldering, 10 sec)	300°C
Operating Junction Temperature Range ...	0°C to 125°C		

PACKAGE/ORDER INFORMATION

<p>FRONT VIEW</p> <p>TAB IS GND</p> <p>3 FB</p> <p>2 GND</p> <p>1 DRIVE</p> <p>ST PACKAGE 3-LEAD PLASTIC SOT-223</p> <p>θ_{JA} AT TAB = 20°C/W</p>	ORDER PART NUMBER	<p>BOTTOM VIEW</p> <p>DRIVE FB GND</p> <p>Z PACKAGE 3-LEAD TO-92 PLASTIC</p> <p>T_{JMAX} = 125°C, θ_{JA} = 220°C/W</p>	ORDER PART NUMBER
	LT1123CST		LT1123CZ
	ST PART MARKING		
	1123		

Consult LTC Marketing for parts specified with wider operating temperature ranges.

ELECTRICAL CHARACTERISTICS

The ● denotes the specifications which apply over the full operating temperature range, otherwise specifications are at $T_A = 25^\circ\text{C}$.

PARAMETER	CONDITIONS	MIN	TYP	MAX	UNITS
Feedback Voltage	$I_{DRIVE} = 10\text{mA}$, $T_J = 25^\circ\text{C}$	4.90	5.00	5.10	V
	$5\text{mA} \leq I_{DRIVE} \leq 100\text{mA}$ $3\text{V} \leq V_{DRIVE} \leq 20\text{V}$	● 4.80	5.00	5.20	V
Feedback Pin Bias Current	$V_{FB} = 5.00\text{V}$, $2\text{V} \leq V_{DRIVE} \leq 15\text{V}$	●	300	500	μA
Drive Current	$V_{FB} = 5.20\text{V}$, $2\text{V} \leq V_{DRIVE} \leq 15\text{V}$	●	0.45	1.0	mA
	$V_{FB} = 4.80\text{V}$, $V_{DRIVE} = 3\text{V}$	●	125	170	
	$V_{FB} = 0.5\text{V}$, $V_{DRIVE} = 3\text{V}$, $0^\circ\text{C} \leq T_J \leq 100^\circ\text{C}$	●	25	100	150
Drive Pin Saturation Voltage	$I_{DRIVE} = 10\text{mA}$, $V_{FB} = 4.5\text{V}$		1.4		V
	$I_{DRIVE} = 125\text{mA}$, $V_{FB} = 4.5\text{V}$		2.0		
Line Regulation	$5\text{V} < V_{DRIVE} < 20\text{V}$	●	1.0	± 20	mV
Load Regulation	$\Delta I_{DRIVE} = 10$ to 100mA	●	-5	-50	mV
Temperature Coefficient of V_{OUT}			0.2		mV/°C

Note 1: Absolute Maximum Ratings are those values beyond which the life of the device may be impaired.

TYPICAL PERFORMANCE CHARACTERISTICS

Feedback Pin Bias Current vs Temperature

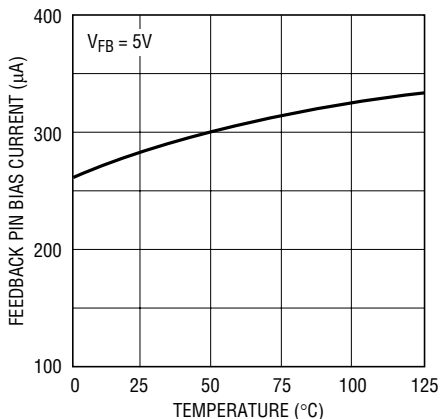

LT1123 G01

Minimum Drive Pin Current vs Temperature

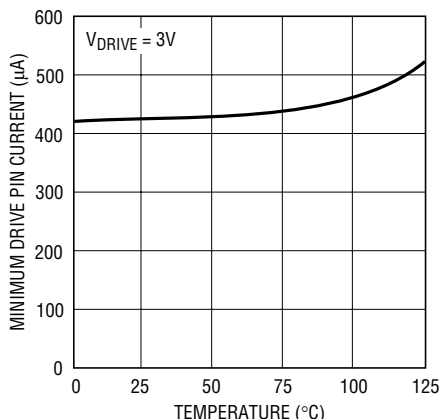

LT1123 G02

Drive Current vs Feedback Pin Voltage

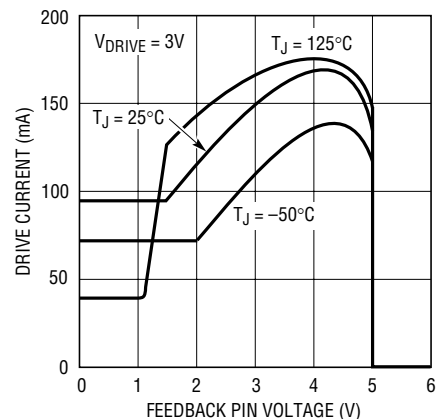

LT1123 G03

Feedback Pin Bias Current vs Feedback Pin Voltage

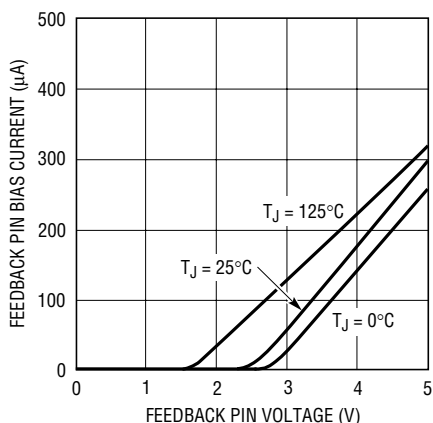

LT1123 G04

Drive Pin Saturation Voltage vs Drive Current

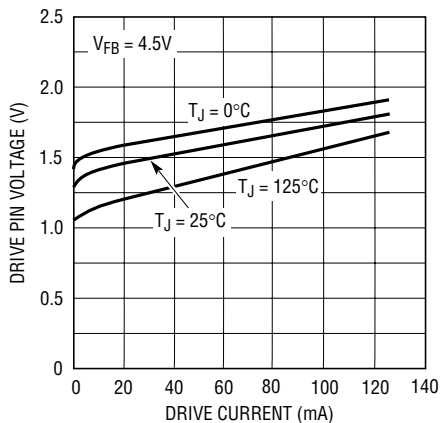

LT1123 G05

Output Voltage vs Temperature

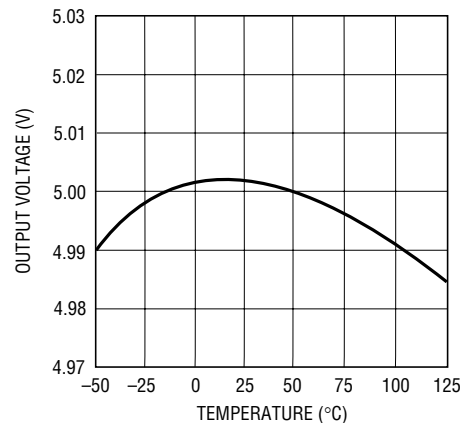

LT1123 G06

PIN FUNCTIONS

Drive Pin: The drive pin serves two functions. It provides current to the LT1123 for its internal circuitry including start-up, bias, current limit, thermal limit and a portion of the base drive current for the output Darlington. The sum total of these currents (450µA typical) is equal to the minimum drive current. This current is listed in the specifications as Drive Current with $V_{FB} = 5.2V$. This is the minimum current required by the drive pin of the LT1123.

The second function of the drive pin is to sink the base drive current of the external PNP pass transistor. The available drive current is specified for two conditions.

Drive current with $V_{FB} = 4.80V$ gives the range of current available under nominal operating conditions, when the device is regulating. Drive current with $V_{FB} = 0.5V$ gives the range of drive current available with the feedback pin pulled low as it would be during start-up or during a short-circuit fault. The drive current available when the feedback pin is pulled low is less than the drive current available when the device is regulating ($V_{FB} = 5V$). This can be seen in the curve of Drive Current vs V_{FB} Voltage in the Typical Performance Characteristics curves. This can provide some foldback in the current limit of the regulator circuit.

PIN FUNCTIONS

All internal circuitry connected to the drive pin is designed to operate at the saturation voltage of the Darlington output driver (1.4 to 2V). This allows a resistor to be inserted between the base of the external PNP device and the drive pin. This resistor is used to limit the base drive to the external PNP below the value set internally by the LT1123, and also to help limit power dissipation in the LT1123. The operating voltage range of this pin is from 0V to 30V. Pulling this pin below ground by more than one V_{BE} will forward bias the substrate diode of the device. This condition can only occur if the power supply leads are

reversed and will not damage the device if the current is limited to less than 200mA.

Feedback Pin (V_{FB}): The feedback pin also serves two functions. It provides a path for the bias current of the reference and error amplifier and contributes a portion of the drive current for the Darlington output driver. The sum total of these currents is the Feedback Pin Bias Current (300 μ A typical). The second function of this pin is to provide the voltage feedback to the error amplifier.

SIMPLIFIED BLOCK DIAGRAM

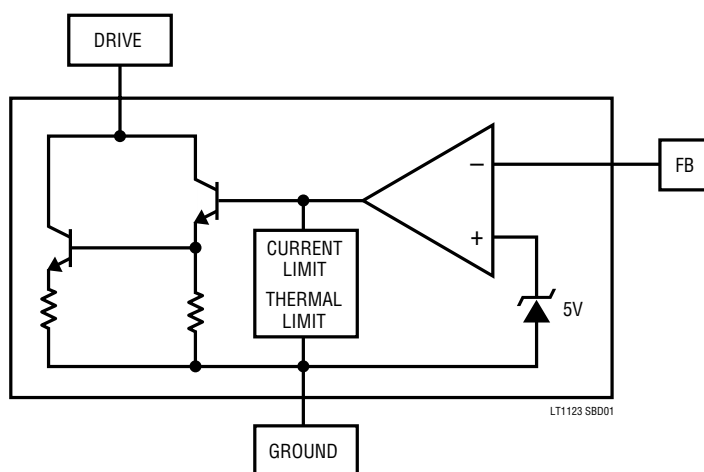

FUNCTIONAL DESCRIPTION

The LT1123 is a 3-pin device designed to be used in conjunction with a discrete PNP transistor to form an inexpensive ultralow dropout regulator. The device incorporates a trimmed 5V bandgap reference, error amplifier, a current-limited Darlington driver and an internal thermal limit circuit. The internal circuitry connected to the drive pin is designed to function at the saturation voltage of the Darlington driver. This allows a resistor to be inserted in

series with the drive pin. This resistor is used to limit the base drive to the PNP and also to limit the power dissipation in the LT1123. The value of this resistor will be defined by the operating requirements of the regulator circuit. The LT1123 is designed to sink a minimum of 125mA of base current. This is sufficient base drive to form a regulator circuit which can supply output currents up to 4A at a dropout voltage of less than 0.75V.

APPLICATIONS INFORMATION

The LT1123 is designed to be used in conjunction with an external PNP transistor. The overall specifications of a regulator circuit using the LT1123 and an external PNP will be heavily dependent on the specifications of the external PNP. While there are a wide variety of PNP transistors available that can be used with the LT1123, the specifications given in typical transistor data sheets are of little use in determining overall circuit performance.

Linear Technology has solved this problem by cooperating with Motorola to design and specify the MJE1123. This transistor is specifically designed to work with the LT1123 as the pass element in a low dropout regulator. The specifications of the MJE1123 reflect the capability of the LT1123. For example, the dropout voltage of the MJE1123 is specified up to 4A collector current with base drive currents that the LT1123 is capable of generating (20mA to 120mA). Output currents up to 4A with dropout voltages less than 0.75V can be guaranteed.

The following sections describe how specifications can be determined for the basic regulator. The charts and graphs are based on the combined characteristics of the LT1123 and the MJE1123. Formulas are included that will enable the user to substitute other transistors that have been characterized. A chart is supplied that lists suggested resistor values for the most popular range of input voltages and output current.

Basic Regulator Circuit

The basic regulator circuit is shown in Figure 1. The LT1123 senses the voltage at its feedback pin and drives the base of the PNP (MJE1123) in order to maintain the output at 5V. The drive pin of the LT1123 can only sink current; R_B is required to provide pull up on the base of the PNP. R_B must be sized so that the voltage drop caused by the minimum drive pin current is less than the emitter/base voltage of the external PNP at light loads. The recommended value for R_B is 620 Ω . For circuits that are required to run at junction temperatures in excess of 100°C the recommended value of R_B is 300 Ω .

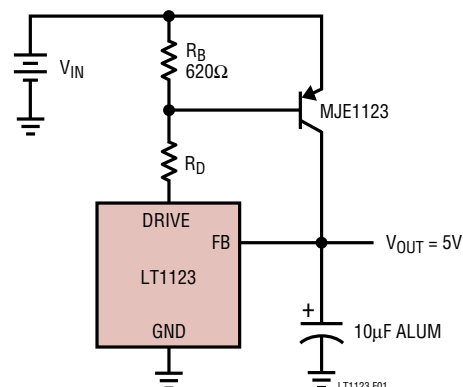

Figure 1. Basic Regulator Circuit

R_D is used to limit the drive current available to the PNP and to limit the power dissipation in the LT1123. Limiting the drive current to the PNP will limit the output current of the regulator which will minimize the stress on the regulator circuit under overload conditions. R_D is chosen based on the operating requirements of the circuit, primarily dropout voltage and output current.

Dropout Voltage

The dropout voltage of an LT1123-based regulator circuit is determined by the V_{CE} saturation voltage of the discrete PNP when it is driven with a base current equal to the available drive current of the LT1123. The LT1123 can sink up to 150mA of base current (150mA typ, 125mA min) when output voltage is up near the regulating point (5V). The available drive current of the LT1123 can be reduced by adding a resistor (R_D) in series with the drive pin (see the section below on current limit). The MJE1123 is specified for dropout voltage (V_{CE} sat.) at several values of output current and up to 120mA of base drive current. The chart below lists the operating points that can be guaranteed by the combined data sheets of the LT1123 and MJE1123. Figure 2 illustrates the chart in graphic form. Although these numbers are only guaranteed by the data sheet at 25°C, Dropout Voltage vs Temperature (Figure 3) clearly shows that the dropout voltage is nearly constant over a wide temperature range.

APPLICATIONS INFORMATION

Dropout Voltage

DRIVE CURRENT	OUTPUT CURRENT	DROPOUT VOLTAGE	
		TYP	MAX
20mA	1A	0.16V	0.3V
	2A	0.25V	0.4V
50mA	1A	0.13V	0.25V
	2A	0.25V	0.4V
120mA	1A	0.2V	0.35V
	4A	0.45V	0.75V

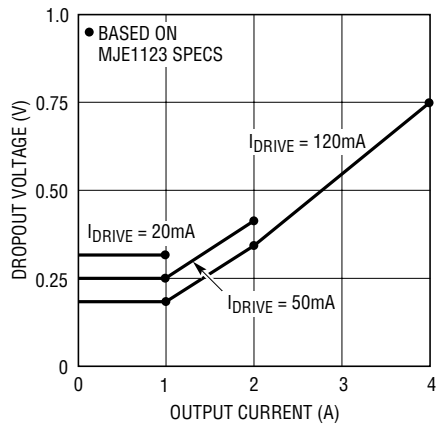

Figure 2. Maximum Dropout Voltage

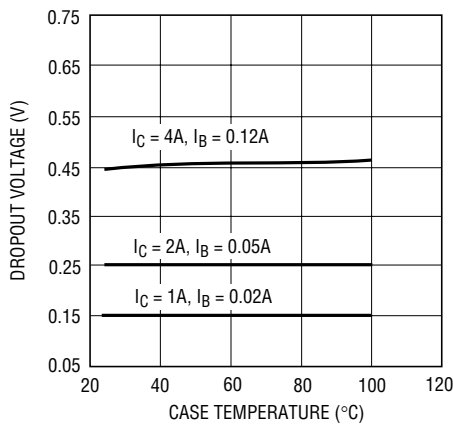

Figure 3. Dropout Voltage vs Temperature

Selecting R_D

In order to select R_D the user should first choose the value of drive current that will give the required value of output current. For circuits using the MJE1123 as a pass

transistor this can be done using the graph of Dropout Voltage vs Output Current (Figure 2). For example, 20mA of drive current will guarantee a dropout voltage of 0.3V at 1A of output current. For circuits using transistors other than the MJE1123 the user must characterize the transistor to determine the drive current requirements. In general it is recommended that the user choose the lowest value of drive current that will satisfy the output current requirements. This will minimize the stress on circuit components during overload conditions.

Figure 4 can be used to select the value of R_D based on the required drive current and the minimum input voltage. Curves are shown for 20mA, 50mA and 120mA drive current corresponding to the specified base drive currents for the MJE1123. The data for the curves was generated using the following formula:

$$R_D = (V_{IN} - V_{BE} - V_{DRIVE}) / (I_{DRIVE} + 1mA)$$

where:

V_{IN} = the minimum input voltage to the circuit

V_{BE} = the maximum emitter/base voltage of the PNP pass transistor

V_{DRIVE} = the maximum drive pin voltage of the LT1123

I_{DRIVE} = the minimum drive current required. The current through R_B is assumed to be 1mA

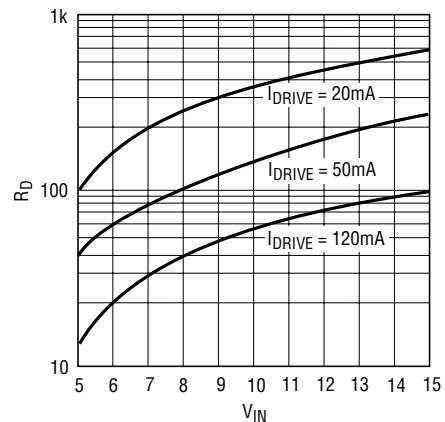

Figure 4. R_D Resistor Value

APPLICATIONS INFORMATION

The following assumptions were made in calculating the data for the curves. Resistors are 5% tolerance and the values shown on the curve are nominal.

For 20mA drive current assume:

$$V_{BE} = 0.95V \text{ at } I_C = 1A$$

$$V_{DRIVE} = 1.75V$$

For 50mA drive current assume:

$$V_{BE} = 1.2V \text{ at } I_C = 2A$$

$$V_{DRIVE} = 1.9V$$

For 120mA drive current assume:

$$V_{BE} = 1.4V \text{ at } I_C = 4A$$

$$V_{DRIVE} = 2.1V$$

The R_D Selection Chart lists the recommended values for R_D for the most useful range of input voltage and output current. The chart includes a number for power dissipation for the LT1123 and R_D .

R_D Selection Chart

INPUT VOLTAGE	OUTPUT CURRENT: DROPOUT VOLTAGE:	0A to 1A 0.3V	0A to 2A 0.4V	0A to 4A 0.75V
5.5V	R_D	120 Ω	43 Ω	—
	Power (LT1123)	0.05W	0.14W	—
	Power (R_D)	0.12W	0.32W	—
6.0V	R_D	150 Ω	51 Ω	20 Ω
	Power (LT1123)	0.05W	0.15W	0.37W
	Power (R_D)	0.13W	0.35W	0.76W
7.0V	R_D	180 Ω	75 Ω	27 Ω
	Power (LT1123)	0.06W	0.14W	0.38W
	Power (R_D)	0.16W	0.36W	0.89W
8.0V	R_D	240 Ω	91 Ω	36 Ω
	Power (LT1123)	0.06W	0.15W	0.38W
	Power (R_D)	0.17W	0.42W	0.97W
9.0V	R_D	270 Ω	110 Ω	43 Ω
	Power (LT1123)	0.20W	0.16W	0.41W
	Power (R_D)	0.07W	0.47W	1.11W
10.0V	R_D	330 Ω	130 Ω	51 Ω
	Power (LT1123)	0.22W	0.17W	0.43W
	Power (R_D)	0.07W	0.52W	1.25W

Note that in some conditions R_D may be replaced with a short. This is possible in circuits where an overload is unlikely and the input voltage and drive requirements are low. See the section on Thermal Considerations for more information.

Current Limit

For regulator circuits using the LT1123, current limiting is achieved by limiting the base drive to the external PNP pass transistor. This means that the actual system current limit will be a function of both the current limit of the LT1123 and the Beta of the external PNP. Beta-based current limit schemes are normally not practical because of uncertainties in the Beta of the pass transistor. Here the drive characteristics of the LT1123 combined with the Beta characteristics of the MJE1123 can provide reliable Beta-based current limiting. This is shown in Figure 5 where the current limit of 30 randomly selected transistors is plotted. The spread of current limit is reasonably well controlled.

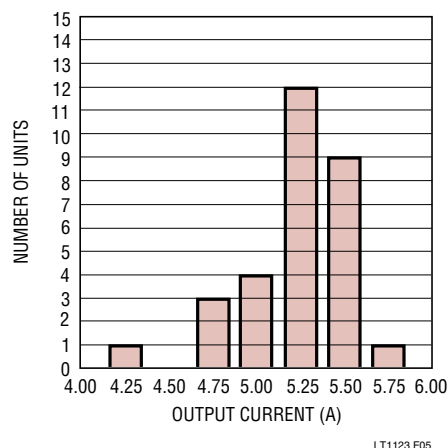

Figure 5. Short-Circuit Current for 30 Random Devices

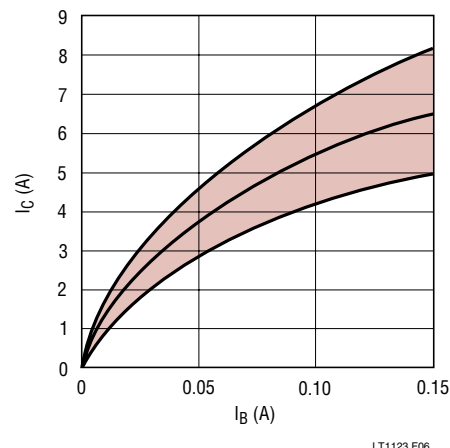

Figure 6. MJE1123 I_C vs I_B

APPLICATIONS INFORMATION

The curve in Figure 6 can be used to determine the range of current limit of an LT1123 regulator circuit using an MJE1123 as a pass transistor. The curve was generated using the Beta versus I_C curve of the MJE1123. The minimum and maximum value curves are extrapolated from the minimum and maximum Beta specifications.

Thermal Conditions

The thermal characteristics of three components need to be considered; the LT1123, the pass transistor and R_D . Power dissipation should be calculated based on the worst-case conditions seen by each component during normal operation.

The worst-case power dissipation in the LT1123 is a function of drive current, supply voltage and the value of R_D . Worst-case dissipation for the LT1123 occurs when the drive current is equal to approximately one half of its maximum value. Figure 7 plots the worst-case power dissipation in the LT1123 versus R_D and V_{IN} . The graph was generated using the following formula:

$$P_D = \frac{(V_{IN} - V_{BE})^2}{4R_D}; R_D > 10\Omega$$

where:

V_{BE} = the emitter/base voltage of the PNP pass transistor (assumed to be 0.6V)

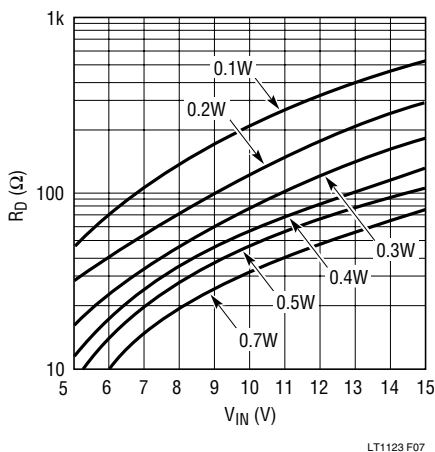

Figure 7. Power in LT1123

For some operating conditions R_D may be replaced with a short. This is possible in applications where the operating requirements (input voltage and drive current) are at the low end and the output will not be shorted. For $R_D = 0$ the following formula may be used to calculate the maximum power dissipation in the LT1123.

$$P_D = (V_{IN} - V_{BE})(I_{DRIVE})$$

where:

V_{IN} = maximum input voltage

V_{BE} = emitter/base voltage of PNP

I_{DRIVE} = required maximum drive current

The maximum junction temperature rise above ambient for the LT1123 will be equal to the worst-case power dissipation multiplied by the thermal resistance of the device. The thermal resistance of the device will depend upon how the device is mounted, and whether a heat sink is used. Measurements show that one of the most effective ways of heat sinking the TO-92 package is by utilizing the PC board traces attached to the leads of the package. The table below lists several methods of mounting and the measured value of thermal resistance for each method. All measurements were done in still air.

	THERMAL RESISTANCE
Package alone	220°C/W
Package soldered into PC board with plated through holes only	175°C/W
Package soldered into PC board with 1/4 sq. in. of copper trace per lead	145°C/W
Package soldered into PC board with plated through holes in board, no extra copper trace, and a clip-on type heat sink:	
Thermalloy type 2224B	160°C/W
Aavid type 5754	135°C/W

The maximum operating junction temperature of the LT1123 is 125°C. The maximum operating ambient temperature will be equal to 125°C minus the maximum junction temperature rise above ambient.

The worst-case power dissipation in R_D needs to be calculated so that the power rating of the resistor can be determined. The worst-case power in the resistor will occur when the drive current is at a maximum. Figure 8 plots the required power rating of R_D versus supply

APPLICATIONS INFORMATION

voltage and resistor value. Power dissipation can be calculated using the following formula:

$$P_{RD} = \frac{(V_{IN} - V_{BE} - V_{DRIVE})^2}{R}$$

where:

V_{BE} = emitter/base voltage of the PNP pass transistor

V_{DRIVE} = voltage at the drive pin of the LT1123
= V_{SAT} of the drive pin in the worst case

The worst-case power dissipation in the PNP pass transistor is simply equal to:

$$P_{MAX} = (V_{IN} - V_{OUT})(I_{OUT})$$

where

V_{IN} = Maximum V_{IN}

I_{OUT} = Maximum I_{OUT}

The thermal resistance of the MJE1123 is equal to:

70°C/W Junction to Ambient (no heat sink)

1.67°C/W Junction to Case

The PNP will normally be attached to either a chassis or a heat sink so the actual thermal resistance from junction to ambient will be the sum of the PNP's junction to case thermal resistance and the thermal resistance of the heat sink or chassis. For nonstandard heat sinks the user will need to determine the thermal resistance by experiment.

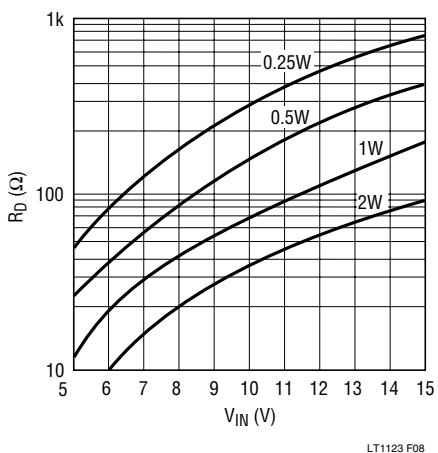

Figure 8. Power in R_D

The maximum junction temperature rise above ambient for the PNP pass transistor will be equal to the maximum power dissipation times the thermal resistance, junction to ambient, of the PNP. The maximum operating junction temperature of the MJE1123 is 150°C. The maximum operating ambient temperature for the MJE1123 will be equal to 150°C minus the maximum junction temperature rise.

The SOT-223 package is designed to be surface mounted. Heat sinking is accomplished by using the heat spreading capabilities of the PC board and its copper traces. The thermal resistance from junction to ambient can be as low as 50°C/W. This requires a reasonably sized PC board with at least one layer of copper to spread the heat across the board and couple it into the surrounding air.

The table below can be used as a guideline in estimating thermal resistance. Data for the table was generated using 1/16" FR-4 board with 1oz copper foil.

Table 1.

Copper Area		Board Area	Thermal Resistance (Junction to Ambient)
Topside*	Backside		
2500 sq. mm	2500 sq. mm	2500 sq. mm	50°C/W
1000 sq. mm	2500 sq. mm	2500 sq. mm	50°C/W
225 sq. mm	2500 sq. mm	2500 sq. mm	58°C/W
100 sq. mm	2500 sq. mm	2500 sq. mm	64°C/W
1000 sq. mm	1000 sq. mm	1000 sq. mm	57°C/W
1000 sq. mm	0	1000 sq. mm	60°C/W

* Tab of device attached to topside copper

For the LT1123 the tab is ground so that plated through holes can be used to couple the tab both electrically and thermally to the ground plane layer of the board. This will help to lower the thermal resistance.

Thermal Limiting

The thermal limit of the LT1123 can be used to protect both the LT1123 and the PNP pass transistor. This is accomplished by thermally coupling the LT1123 to the power transistor. There are clip type heat sinks available for the TO-92 package that will allow the LT1123 to be mounted to the same heat sink as the PNP pass transistor. One example is manufactured by IERC (part #RUR67B1CB). The LT1123 should be mounted as close as possible to the

APPLICATIONS INFORMATION

PNP. If the output of the regulator circuit can be shorted, heat sinking must be adequate to limit the rate of temperature rise of the power device to approximately 50°C/minute. This can be accomplished with a fairly small heat sink, on the order of 3 to 4 square inches of surface area.

Design Example

Given the following operating requirements:

$$5.5V < V_{IN} < 7V$$

$$I_{OUTMAX} = 1.5A$$

$$\text{Max ambient temperature} = 70^{\circ}C$$

$$V_{OUT} = 5V$$

1. The first step is to determine the required drive current. This can be found from the Maximum Dropout Voltage curve. 50mA of drive current will guarantee 0.4V dropout at an output current of 2A. This satisfies our requirements.

$$I_{DRIVE} = 50mA$$

2. The next step is to determine the value of R_D . Based on 50mA of drive current and a minimum input voltage of 5.5V, we can select R_D from the graph of Figure 4. From the graph the value of R_D is equal to 50Ω, so we should use the next lowest 5% value which is 47Ω.

$$R_D = 47\Omega$$

3. We can now look at the thermal requirements of the circuit.

Worst-case power in the LT1123 will be equal to:

$$\frac{(V_{IN(MAX)} - V_{BE})^2}{4R_D}$$

Given: $V_{IN(MAX)} = 7V$, $V_{BE} = 0.6V$, $R_D = 47\Omega$

Then: $P_{MAX} (LT1123) = 0.22W$.

Assuming a thermal resistance of 150°C/W, the maximum junction temperature rise above ambient will be equal to $(P_{MAX})(150^{\circ}C/W) = 33^{\circ}C$. The maximum operating junction temperature will be equal to the maximum ambient temperature plus the junction temperature rise above ambient. In this case we have (maximum ambient = 70°C) plus (junction temperature rise = 33°C) is equal to 103°C. This is well below the maximum operating junction temperature of 125°C for the LT1123.

The power rating for R_D can be found from the plot of Figure 8 using $V_{IN} = 7V$ and $R_D = 47\Omega$. From the plot, R_D should be sized to dissipate a minimum of 1/2W.

The worst-case power dissipation, for normal operation, in the MJE1123 will be equal to:

$$(V_{INMAX} - V_{OUT})(I_{OUTMAX}) = (7V - 5V)(1.5A) = 3W$$

The maximum operating junction temperature of the MJE1123 is 150°C. The difference between the maximum operating junction temperature of 150°C and the maximum ambient temperature of 70°C is 80°C. The device must be mounted to a heat sink which is sized such that the thermal resistance from the junction of the MJE1123 to ambient is less than $80^{\circ}C/3W = 26.7^{\circ}C/W$.

It is recommended that the LT1123 be thermally coupled to the MJE1123 so that the thermal limit circuit of the LT1123 can protect both devices. In this case the ambient temperature for the LT1123 will be equal to the temperature of the heat sink. The heat sink temperature, under normal operating conditions, will have to be limited such that the maximum operating junction temperature of the LT1123 is not exceeded.

Refer to Linear Technology's list of Suggested Manufacturers of Specialized Components for information on where to find the required heat sinks, resistors and capacitors. This listing is available through Linear Technology's marketing department.

TYPICAL APPLICATIONS

Isolated Feedback for Switching Regulators

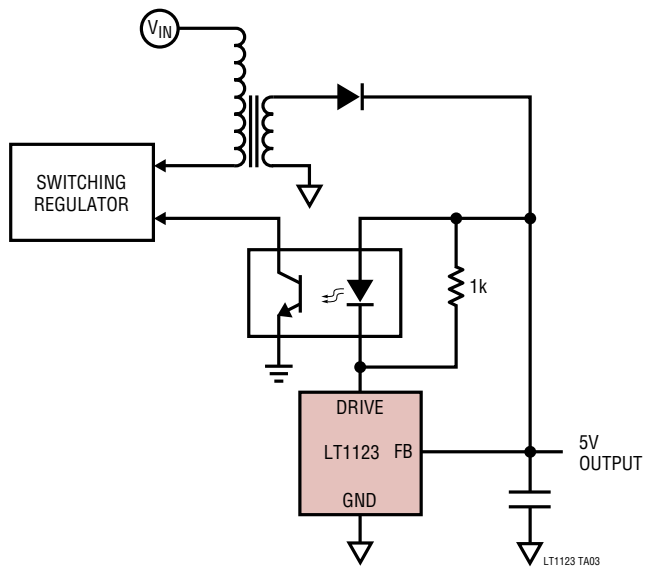

5V/2A Regulator with Remote Sensing

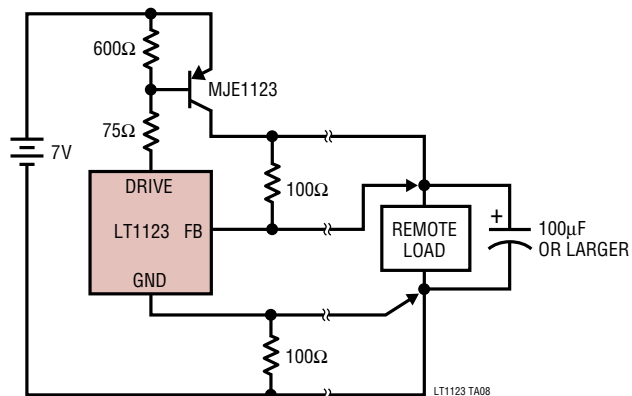

5V Regulator with Antisat Minimizes Ground Pin Current in Dropout

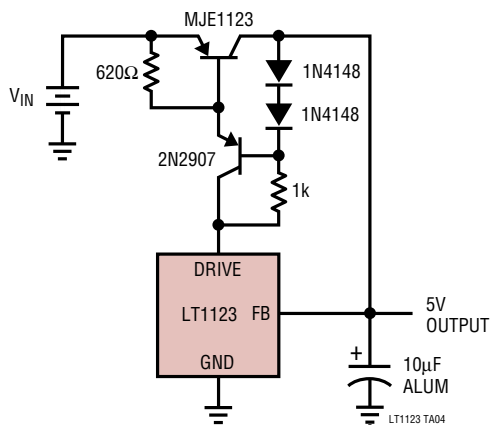

TYPICAL APPLICATIONS

5V/1A Regulator with Shutdown

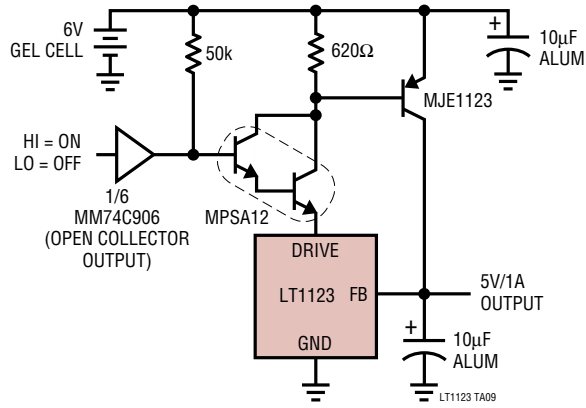

Undervoltage Indicator On for $V_{IN} < (V_Z + 5V)$

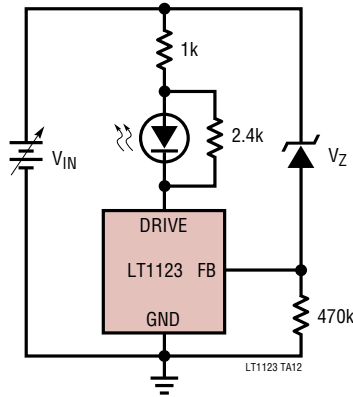

5V Shunt Regulator or Voltage Clamp

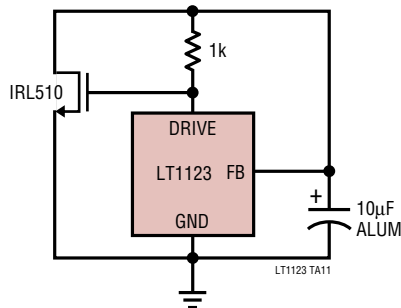

TYPICAL APPLICATIONS

Battery Backup Regulator

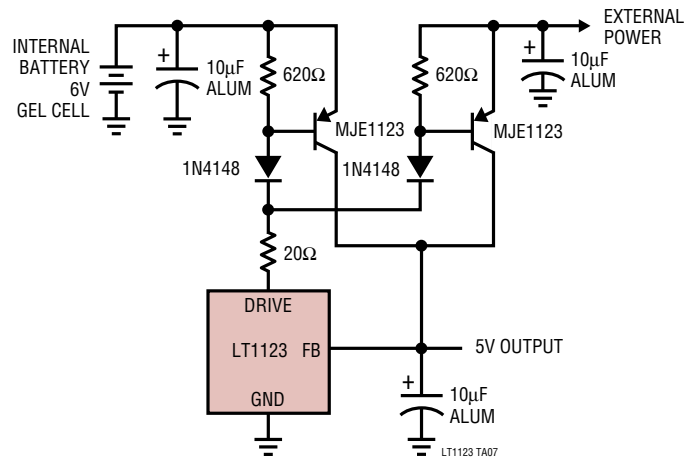

Adjusting V_{OUT}

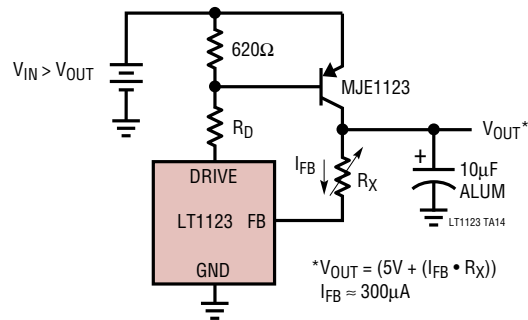

Adjusting V_{OUT}

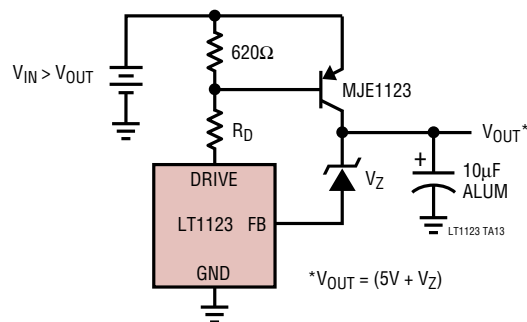

PACKAGE DESCRIPTION

ST Package
3-Lead Plastic SOT-223
 (Reference LTC DWG # 05-08-1630)

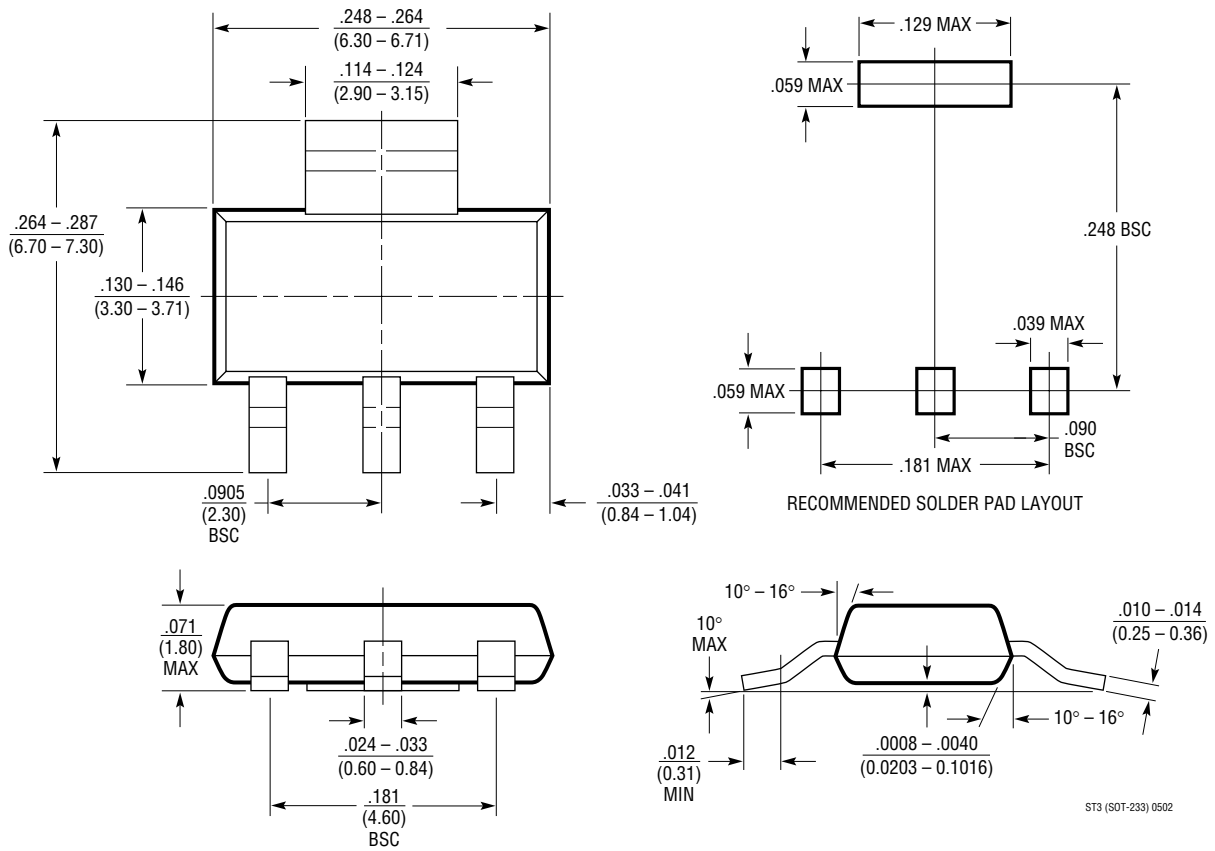

ST3 (SOT-233) 0502

PACKAGE DESCRIPTION

Z Package 3-Lead Plastic TO-92 (Similar to TO-226) (Reference LTC DWG # 05-08-1410)

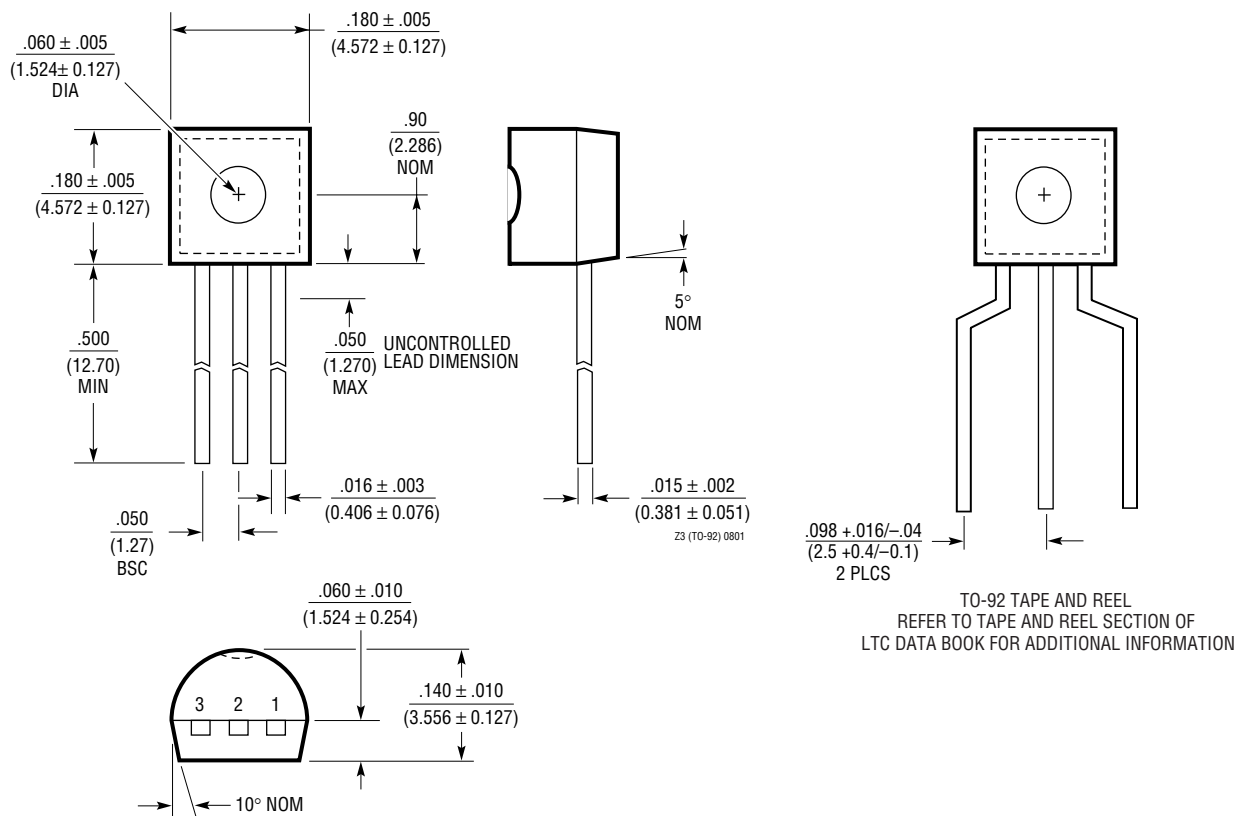

TYPICAL APPLICATIONS

5V/1A Regulator with Shutdown

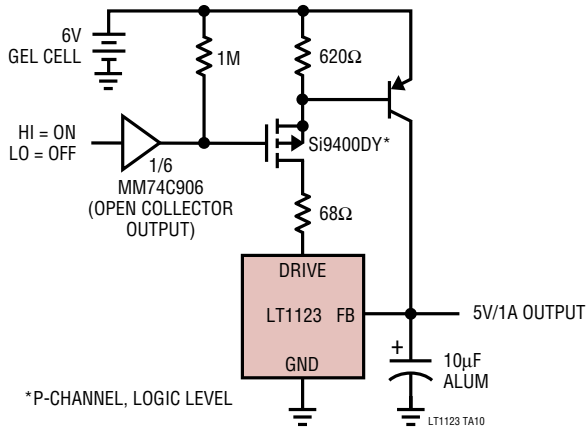

5V Regulator Powered by Multiple Battery Packs*

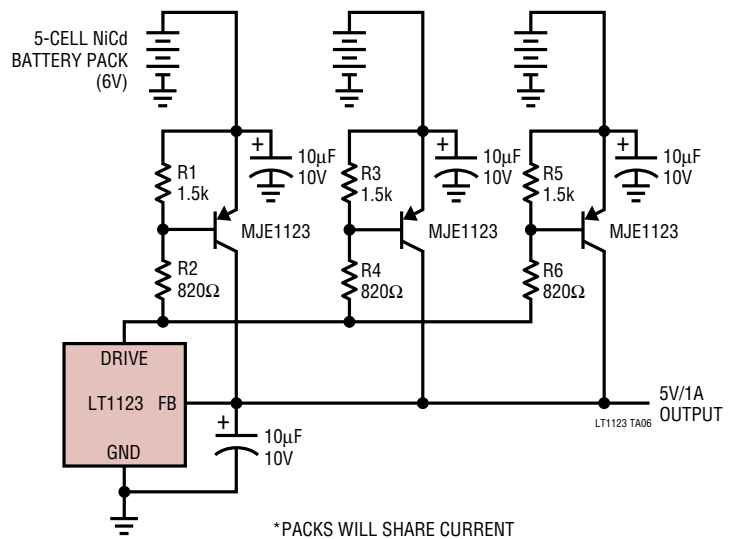

RELATED PARTS

PART NUMBER	DESCRIPTION	COMMENTS
LT1083/4/5	7.5A, 5A, 3A Low Dropout Positive Regulators	1.5V Dropout Voltage, 0.1% Load Regulator, $1.25V_{REF}$
LT1117	800mA Low Dropout Regulator	SOT-223 Package, 0.4% Load Regulator
LT1121	150mA, Low Dropout LDO	0.4V Dropout Voltage, $I_Q = 30\mu A$
LT1761	100mA, Low Noise LDO	300mV Dropout Voltage, $I_Q = 20\mu A$
LT1763	1.5A, Low Noise, Fast Transient Response LDO	Optimized for Hot Response

Looking for pricing, stock, or lifecycle information?

Click below to explore more details on WIN SOURCE:

 [View LT1123CZ#PBF on WIN SOURCE](#)

 [Linear Technology](#) Information

Optimize Your Supply Chain with WIN SOURCE Solutions

-  Global Sourcing Solution
-  Obsolete Management
-  Cost Control Management
-  Shortage Management
-  Alternative Solution
-  Excess Inventory Management