



**THE DATASHEET OF
LT1014DMDWREP**



QUAD PRECISION OPERATIONAL AMPLIFIER

FEATURES

- **Single-Supply Operation:**
Input Voltage Range Extends to Ground, and Output Swings to Ground While Sinking Current
- **Input Offset Voltage 300 mV Max at 25°C**
- **Offset Voltage Temperature Coefficient 2.5 $\mu\text{V}/^\circ\text{C}$ Max**
- **Input Offset Current 1.5 nA Max at 25°C**
- **High Gain 1.2 V/ μV Min ($R_L = 2 \text{ k}\Omega$), 0.5 V/ μV Min ($R_L = 600 \Omega$)**
- **Low Supply Current 2.2 mA Max at 25°C**
- **Low Peak-to-Peak Noise Voltage 0.55 μV Typ**
- **Low Current Noise 0.07 pA/ $\sqrt{\text{Hz}}$ Typ**

SUPPORTS DEFENSE, AEROSPACE, AND MEDICAL APPLICATIONS

- **Controlled Baseline**
- **One Assembly/Test Site**
- **One Fabrication Site**
- **Available in Military (–55°C/125°C) Temperature Range⁽¹⁾**
- **Extended Product Life Cycle**
- **Extended Product-Change Notification**
- **Product Traceability**

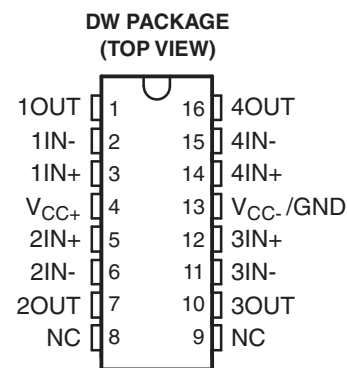

(1) Additional temperature ranges are available - contact factory

DESCRIPTION

The LT1014D is a quad precision operational amplifier with 14-pin industry-standard configuration. It features low offset-voltage temperature coefficient, high gain, low supply current, and low noise.

The LT1014D can be operated with both dual $\pm 15\text{-V}$ and single 5-V power supplies. The common-mode input voltage range includes ground, and the output voltage can also swing to within a few millivolts of ground. Crossover distortion is eliminated.

ORDERING INFORMATION⁽¹⁾

T_A	PACKAGE ⁽²⁾		ORDERABLE PART NUMBER	TOP-SIDE MARKING
–55°C to 125°C	SIOC-DW	Reel of 2000	LT1014DMDWREP	LT1014DMEP

(1) For the most current package and ordering information, see the Package Option Addendum at the end of this document, or see the TI Web site at www.ti.com.

(2) Package drawings, standard packing quantities, thermal data, symbolization, and PCB design guidelines are available at www.ti.com/sc/package.



Please be aware that an important notice concerning availability, standard warranty, and use in critical applications of Texas Instruments semiconductor products and disclaimers thereto appears at the end of this data sheet.

SCHEMATIC (EACH AMPLIFIER)

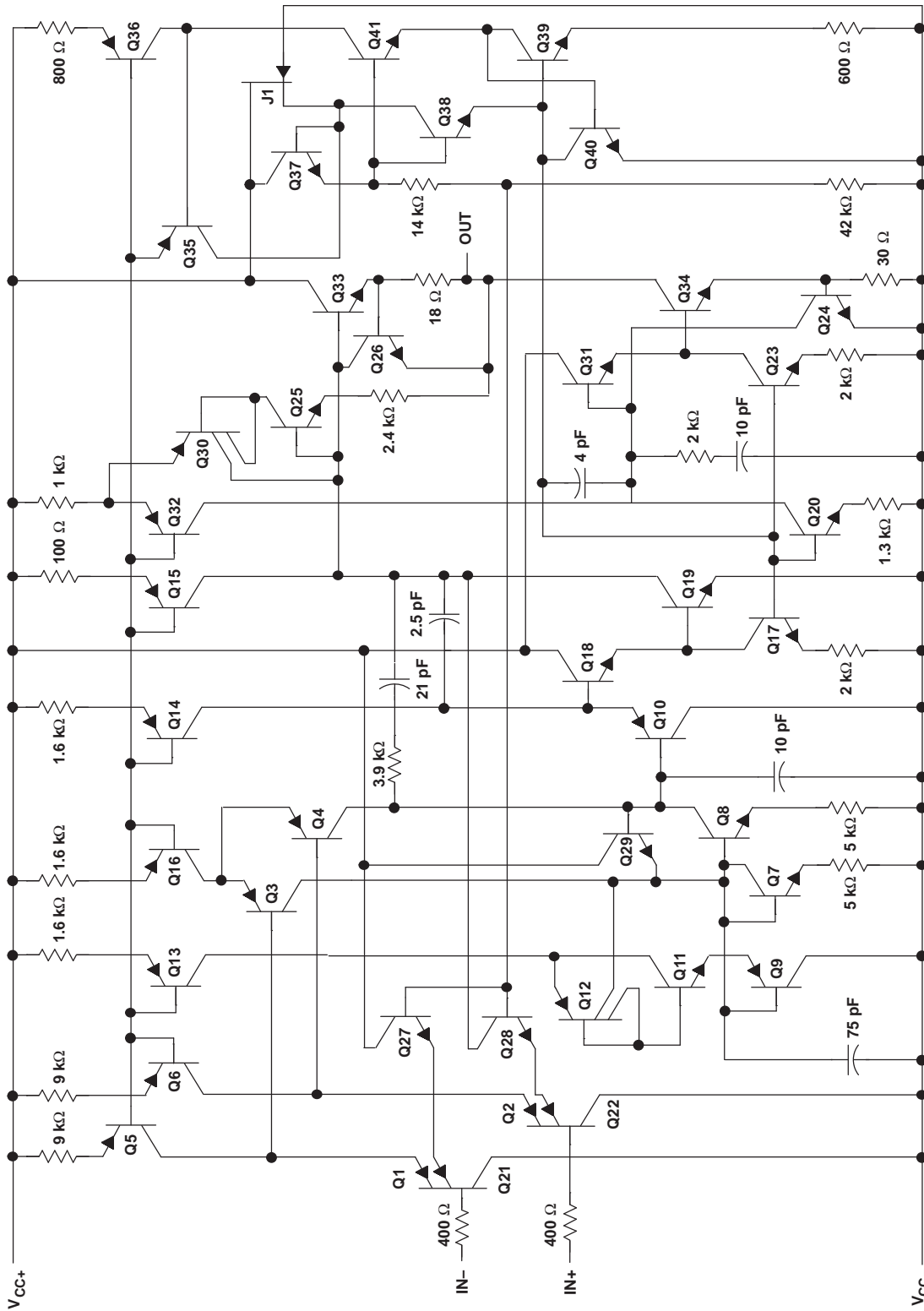

Component values are nominal.

ABSOLUTE MAXIMUM RATINGS

 over operating free-air temperature range (unless otherwise noted) ⁽¹⁾

	MIN	MAX	UNIT
V _{CC} supply voltage ⁽²⁾	-22	22	V
Differential input voltage ⁽³⁾	-30	30	V
V _I Input voltage range (any input) ⁽²⁾	V _{CC-} - 5	V _{CC+}	V
Duration of short-circuit current ⁽⁴⁾	T _A ≤ 25°C		Unlimited
Continuous total power dissipation	See Dissipation Ratings Table		
T _A Operating temperature range	-55	125	°C
T _{stg} Storage temperature range	-65	150	°C
Lead temperature 1,6 mm, at distance 1/16 inch from case for 10s		260	°C

- (1) Stresses beyond those listed under "absolute maximum ratings" may cause permanent damage to the device. These are stress ratings only, and functional operation of the device at these or any other conditions beyond those indicated under "recommended operating conditions" is not implied. Exposure to absolute-maximum-rated conditions for extended periods may affect device reliability.
- (2) All voltage values, except differential voltages, are with respect to the midpoint between V_{CC+} and V_{CC-}.
- (3) Differential voltages are at the noninverting input with respect to the inverting input.
- (4) The output may be shorted to either supply.

DISSIPATION RATINGS

PACKAGE	T _A ≤ 25°C POWER RATING	DERATING FACTOR ABOVE T _A = 25°C	T _A = 70°C POWER RATING	T _A = 105°C POWER RATING	T _A = 125°C POWER RATING
DW	1025 mW	8.2 mW/°C	656 mW	369 mW	205 mW

ELECTRICAL CHARACTERISTICS

 over operating free-air temperature range, V_{CC+} = 5 V, V_{CC-} = 0, V_O = 1.4 V, V_{IC} = 0 (unless otherwise noted)

PARAMETER	TEST CONDITIONS	T _A ⁽¹⁾	MIN	TYP	MAX	UNIT
V _{IO} Input offset voltage	R _S = 50 Ω	25°C		90	450	μV
		Full range		400	1500	
	R _S = 50 Ω, V _{IC} = 0.1 V	125°C		200	750	
I _{IO} Input offset current		25°C		0.2	2	nA
		Full range			10	
I _{IB} Input bias current		25°C		-15	-50	nA
		Full range			-120	
V _{ICR} Common-mode input voltage range		25°C	0 to 3.5	-0.3 to 3.8		V
		Full range	0.1 to 3			
V _{OM} Maximum peak output voltage swing	Output low, no load	25°C		15	25	mV
	Output low, R _L = 600 Ω to GND	25°C		5	10	
		Full range				
	Output low, I _{SINK} = 1 mA	25°C		220	350	V
	Output high, no load	25°C	4	4.4		
	Output high	25°C	3.4	4		
	R _L = 600 Ω to GND	Full range	3.1			
A _{VD} Large-signal differential voltage amplification	V _O = 5 mV to 4 V, R _L = 500 Ω	25°C		1		V/μV
I _{CC} Supply current per amplifier		25°C		0.3	0.5	mA
		Full range			0.65	

- (1) Full range is -55°C to 125°C.

OPERATING CHARACTERISTICS

over operating free-air temperature range, $V_{CC\pm} = 15\text{ V}$, $V_{IC} = 0$, $T_A = 25^\circ\text{C}$ (unless otherwise noted)

PARAMETER		TEST CONDITIONS	MIN	TYP	MAX	UNIT
SR	Slew rate		0.2	0.4		V/ μs
V_n	Equivalent input noise voltage	f = 10 Hz		24		nV/ $\sqrt{\text{Hz}}$
		f = 1kHz		22		
$V_{N(PP)}$	Peak-to-peak equivalent input noise voltage	f = 0.1 Hz to 10 Hz		0.55		μV
I_n	Equivalent input noise current	f = 10 Hz		0.07		pA/ $\sqrt{\text{Hz}}$

TYPICAL CHARACTERISTICS

Table of Graphs

		FIGURE	
V_{IO}	Input offset voltage vs balanced source resistance	Figure 2	
V_{IO}	Input offset voltage vs free-air temperature	Figure 3	
ΔV_{IO}	Warm-up change in input offset voltage vs elapsed time	Figure 4	
I_{IO}	Input offset current vs Input offset current vs free-air temperature	Figure 5	
I_{IB}	Input bias current vs free-air temperature	Figure 6	
V_{IC}	Common-mode input voltage vs input bias current	Figure 7	
A_{VD}	Differential voltage amplification	vs load resistance	Figure 8 Figure 9
		vs frequency	Figure 10 Figure 11
	Channel separation vs frequency	Figure 12	
	Output saturation voltage vs free-air temperature	Figure 13	
CMRR	Common-mode rejection ratio vs frequency	Figure 14	
k_{SVR}	Supply-voltage rejection ratio vs frequency	Figure 15	
I_{CC}	Supply current vs free-air temperature	Figure 16	
I_{OS}	Short-circuit output current vs elapsed time	Figure 17	
V_n	Equivalent input noise voltage vs frequency	Figure 18	
I_n	Equivalent input noise current vs frequency	Figure 18	
$V_{N(PP)}$	Peak-to-peak input noise voltage vs time	Figure 19	
	Pulse response (small signal) vs time	Figure 20 Figure 22	
	Pulse response (large signal) vs time	Figure 21 Figure 23 Figure 24	
	Phase shift vs frequency	Figure 10	

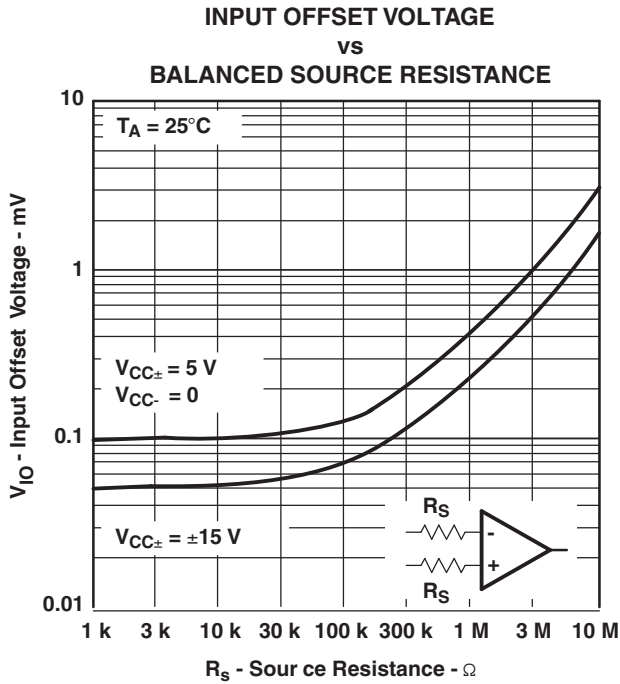

Figure 2.

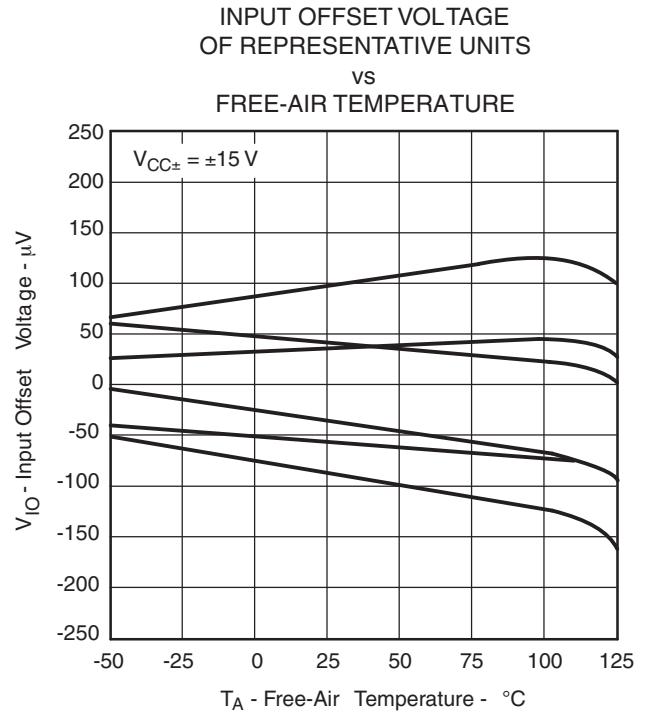

Figure 3.

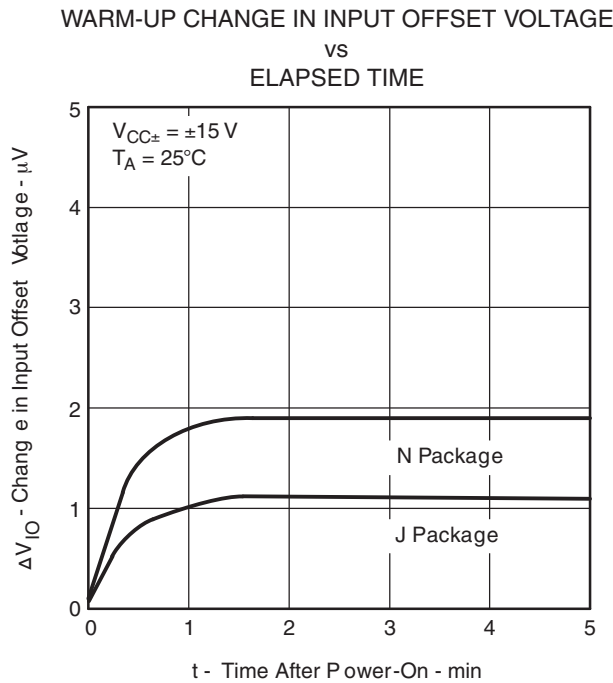

Figure 4.

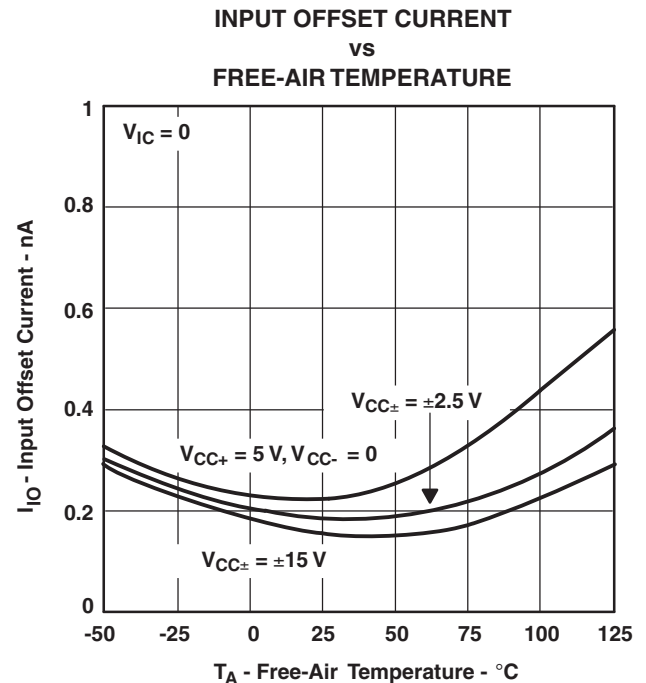

Figure 5.

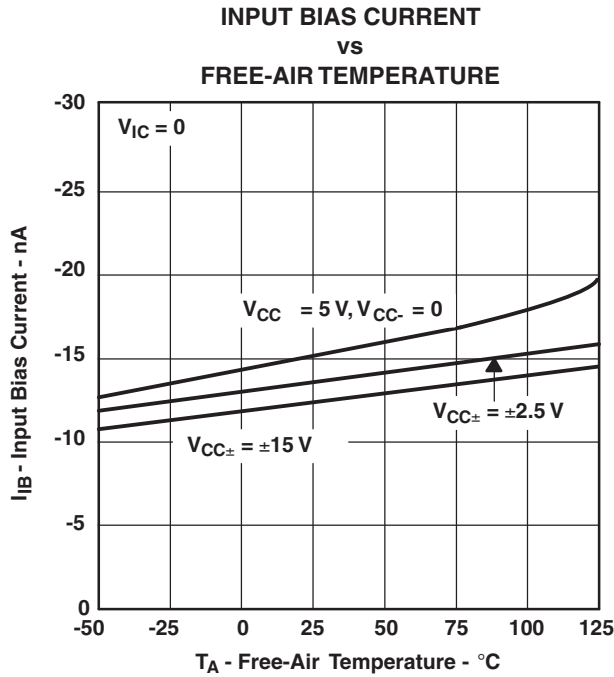

Figure 6.

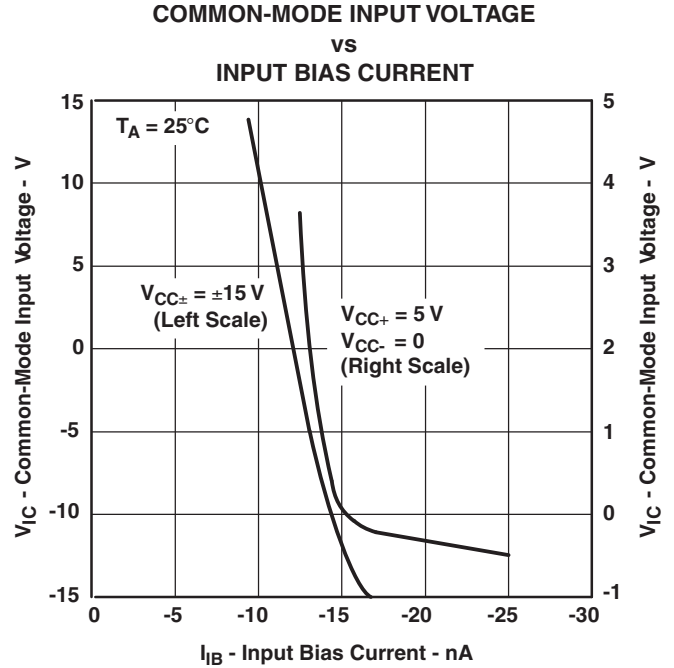

Figure 7.

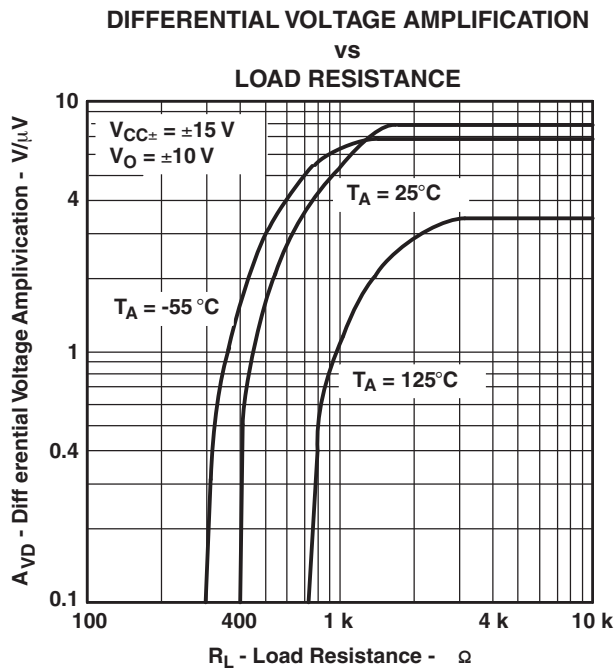

Figure 8.

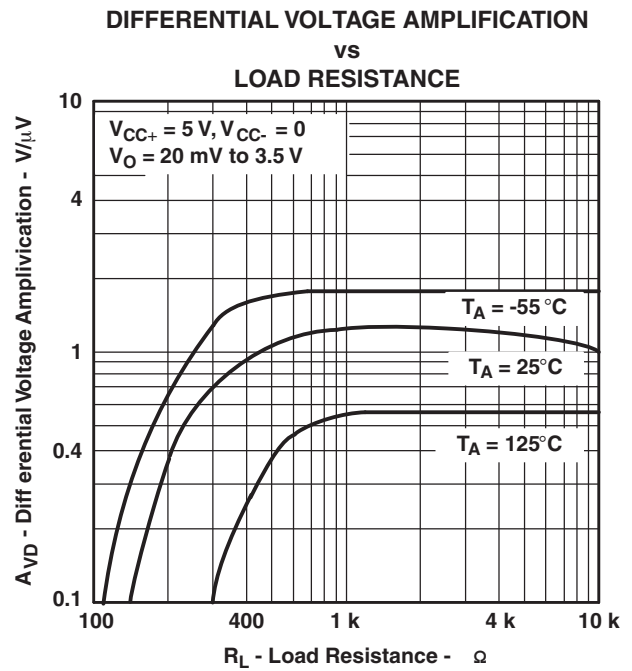

Figure 9.

DIFFERENTIAL VOLTAGE AMPLIFICATION AND PHASE SHIFT vs FREQUENCY

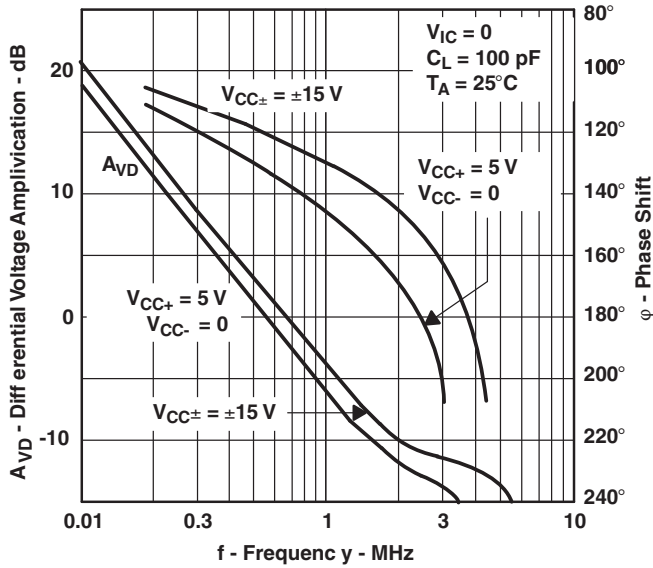

Figure 10.

DIFFERENTIAL VOLTAGE AMPLIFICATION vs FREQUENCY

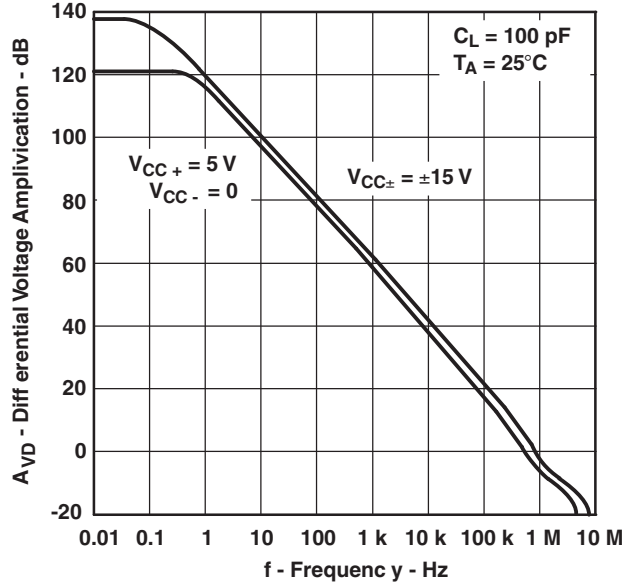

Figure 11.

CHANNEL SEPARATION vs FREQUENCY

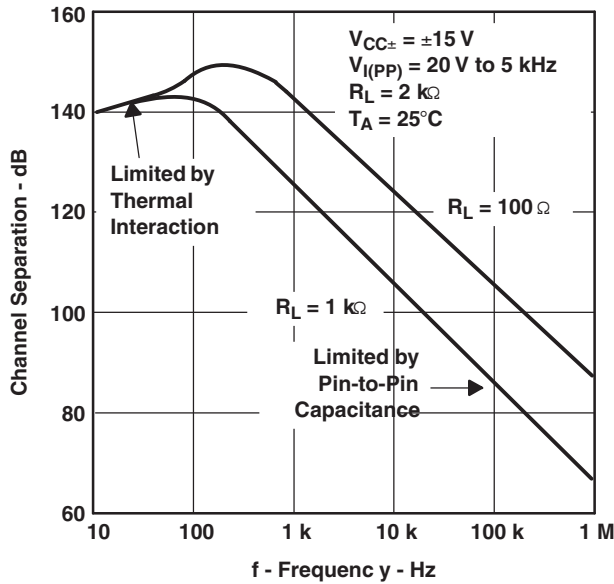

Figure 12.

OUTPUT SATURATION VOLTAGE vs FREE-AIR TEMPERATURE

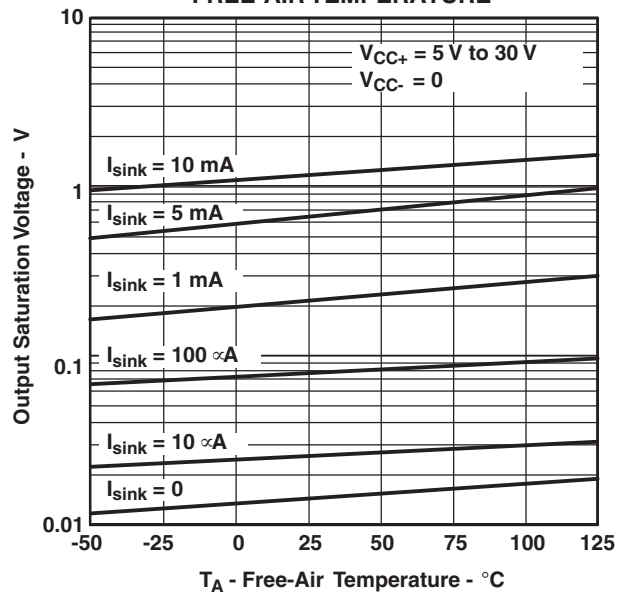
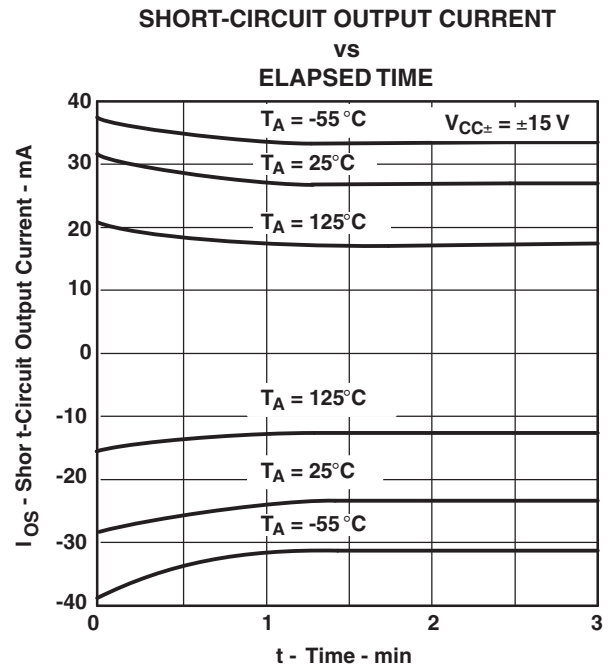
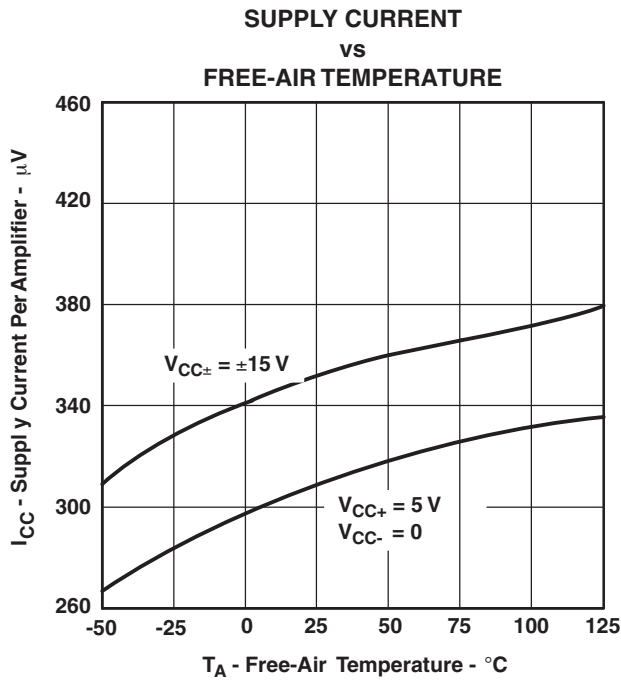
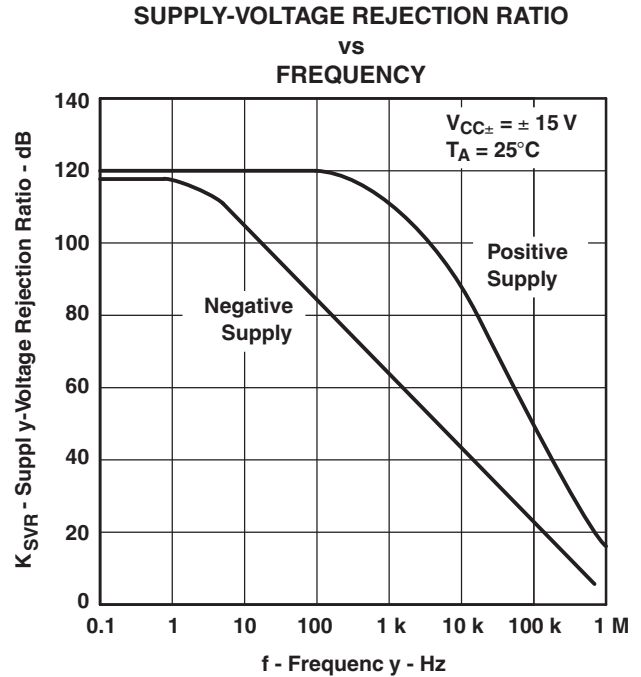
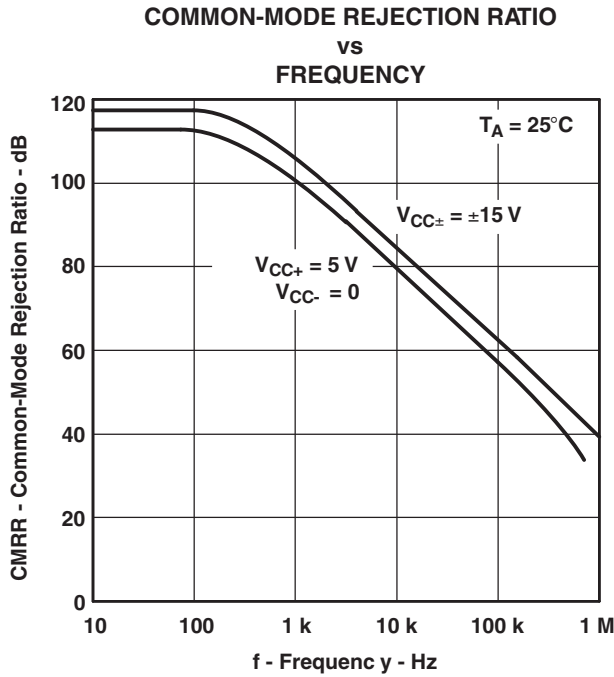

Figure 13.



EQUIVALENT INPUT NOISE VOLTAGE AND EQUIVALENT INPUT NOISE CURRENT VS FREQUENCY

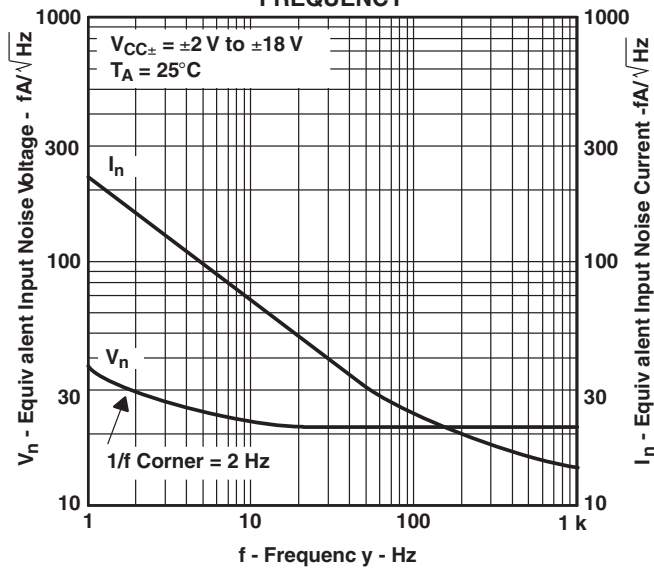

Figure 18.

PEAK-TO-PEAK INPUT NOISE VOLTAGE OVER A 10-SECOND PERIOD VS TIME

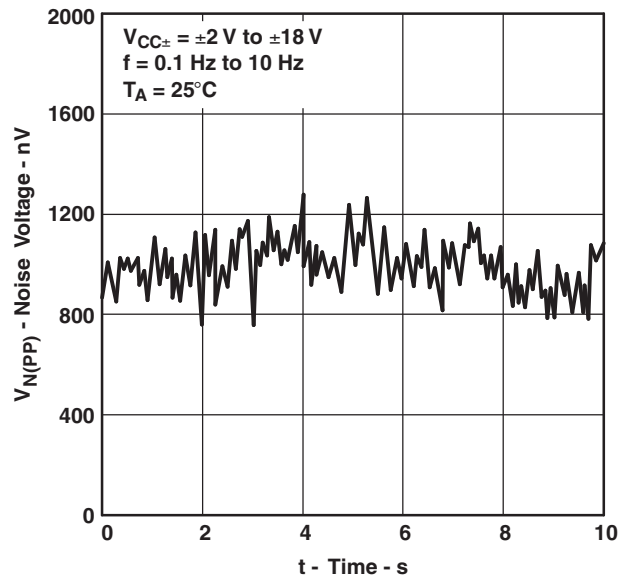

Figure 19.

VOLTAGE-FOLLOWER SMALL-SIGNAL PULSE RESPONSE VS TIME

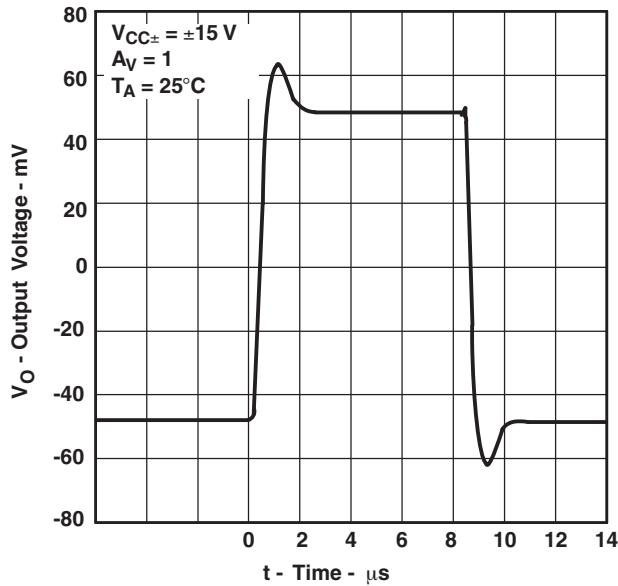

Figure 20.

VOLTAGE-FOLLOWER LARGE-SIGNAL PULSE RESPONSE VS TIME

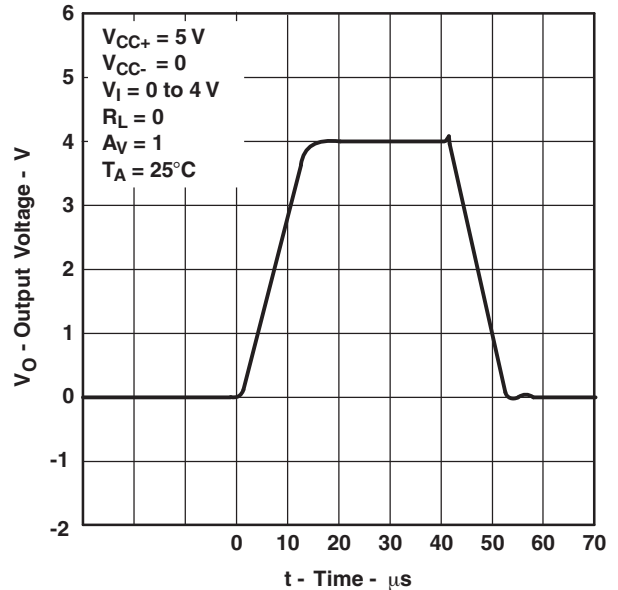

Figure 21.

VOLTAGE-FOLLOWER SMALL-SIGNAL PULSE RESPONSE

VS TIME

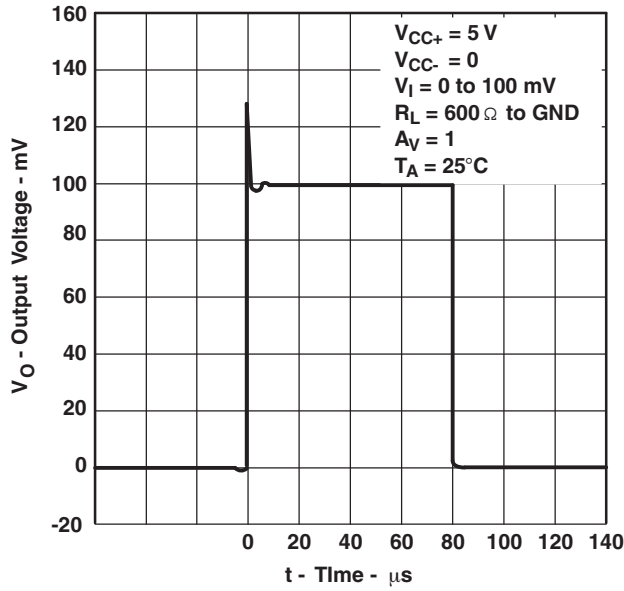

Figure 22.

VOLTAGE-FOLLOWER LARGE-SIGNAL PULSE RESPONSE

VS TIME

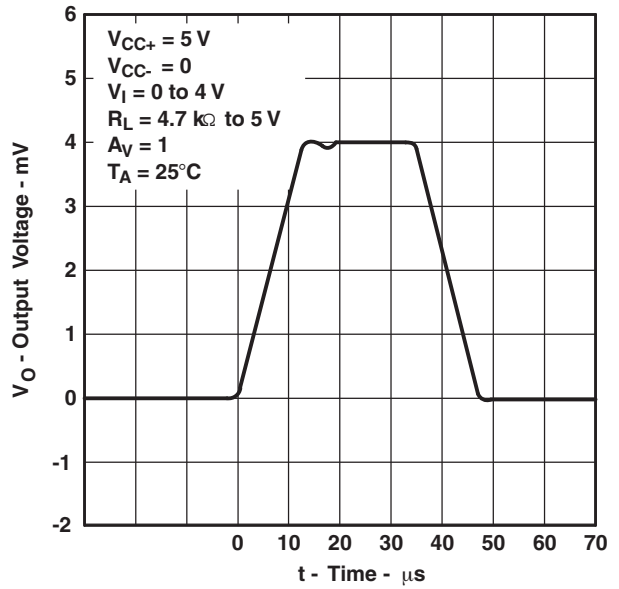

Figure 23.

VOLTAGE-FOLLOWER LARGE-SIGNAL PULSE RESPONSE

VS TIME

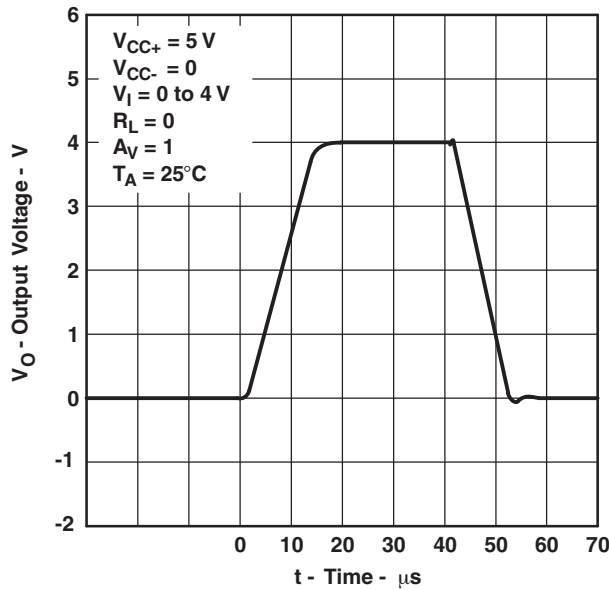

Figure 24.

APPLICATION INFORMATION

SINGLE-SUPPLY OPERATION

The LT1014D is fully specified for single-supply operation ($V_{CC-} = 0$). The common-mode input voltage range includes ground, and the output swings within a few millivolts of ground.

Furthermore, the LT1014D has specific circuitry that addresses the difficulties of single-supply operation, both at the input and at the output. At the input, the driving signal can fall below 0 V, either inadvertently or on a transient basis. If the input is more than a few hundred millivolts below ground, the LT1014D is designed to deal with the following two problems that can occur:

1. On many other operational amplifiers, when the input is more than a diode drop below ground, unlimited current flows from the substrate (V_{CC-} terminal) to the input, which can destroy the unit. On the LT1014D, the 400- Ω resistors in series with the input (see schematic) protect the device even when the input is 5 V below ground.
2. When the input is more than 400 mV below ground (at $T_A = 25^\circ\text{C}$), the input stage of similar type operational amplifiers saturates, and phase reversal occurs at the output. This can cause lockup in servo systems. Because of unique phase-reversal protection circuitry (Q21, Q22, Q27, and Q28), the LT1014D outputs do not reverse, even when the inputs are at -1.5 V (see Figure 25).

However, this phase-reversal protection circuitry does not function when the other operational amplifier on the LT1014D is driven hard into negative saturation at the output. Phase-reversal protection does not work on an amplifier:

- When 4's output is in negative saturation (the outputs of 2 and 3 have no effect)
- When 3's output is in negative saturation (the outputs of 1 and 4 have no effect)
- When 2's output is in negative saturation (the outputs of 1 and 4 have no effect)
- When 1's output is in negative saturation (the outputs of 2 and 3 have no effect)

At the output, other single-supply designs either cannot swing to within 600 mV of ground or cannot sink more than a few microamperes while swinging to ground. The all-npn output stage of the LT1014D maintains its low output resistance and high gain characteristics until the output is saturated. In dual-supply operations, the output stage is free of crossover distortion.

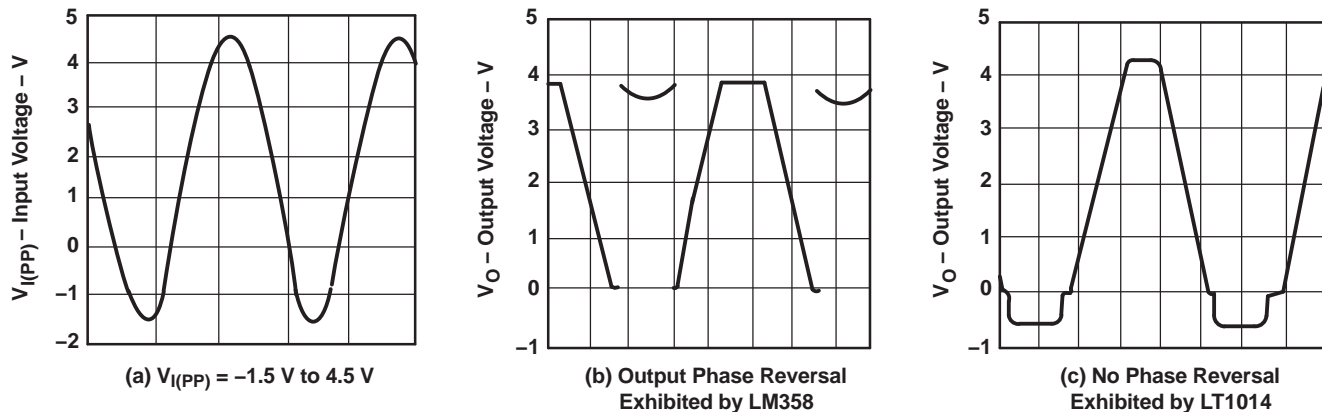

**Figure 25. Voltage-Follower Response
With Input Exceeding the Negative Common-Mode Input Voltage Range**

COMPARATOR APPLICATIONS

The single-supply operation of the LT1014D can be used as a precision comparator with TTL-compatible output. In systems using both operational amplifiers and comparators, the LT1014D can perform multiple duties (see Figure 26 and Figure 27).

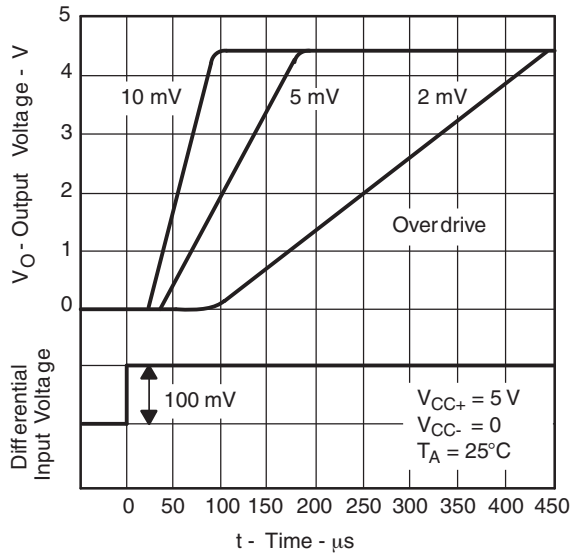

Figure 26. Low-to-High-Level Output Response for Various Input Overdrives

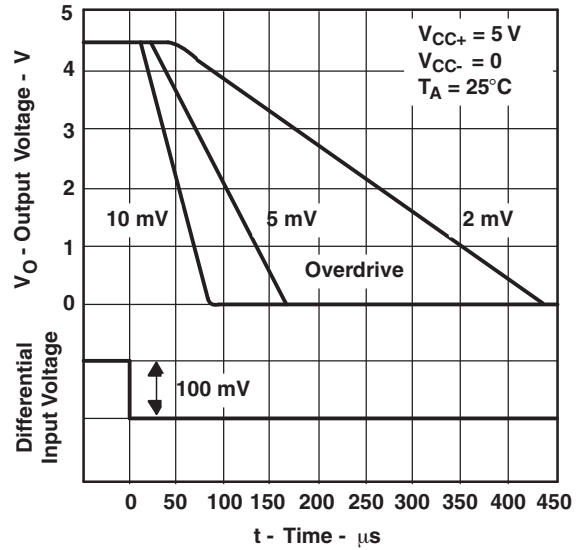

Figure 27. High-to-Low-Level Output Response for Various Input Overdrives

LOW-SUPPLY OPERATION

The minimum supply voltage for proper operation of the LT1014D is 3.4 V (three Ni-Cad batteries). Typical supply current at this voltage is 290 μ A; therefore, power dissipation is only 1 mW per amplifier.

OFFSET VOLTAGE AND NOISE TESTING

Figure 31 shows the test circuit for measuring input offset voltage and its temperature coefficient. This circuit with supply voltages increased to ± 20 V is also used as the burn-in configuration.

The peak-to-peak equivalent input noise voltage of the LT1014D is measured using the test circuit shown in Figure 28. The frequency response of the noise tester indicates that the 0.1-Hz corner is defined by only one zero. The test time to measure 0.1-Hz to 10-Hz noise should not exceed 10 seconds, as this time limit acts as an additional zero to eliminate noise contribution from the frequency band below 0.1 Hz.

An input noise-voltage test is recommended when measuring the noise of a large number of units. A 10-Hz input noise-voltage measurement correlates well with a 0.1-Hz peak-to-peak noise reading because both results are determined by the white noise and the location of the 1/f corner frequency.

Noise current is measured by the circuit and formula shown in Figure 29. The noise of the source resistors is subtracted.

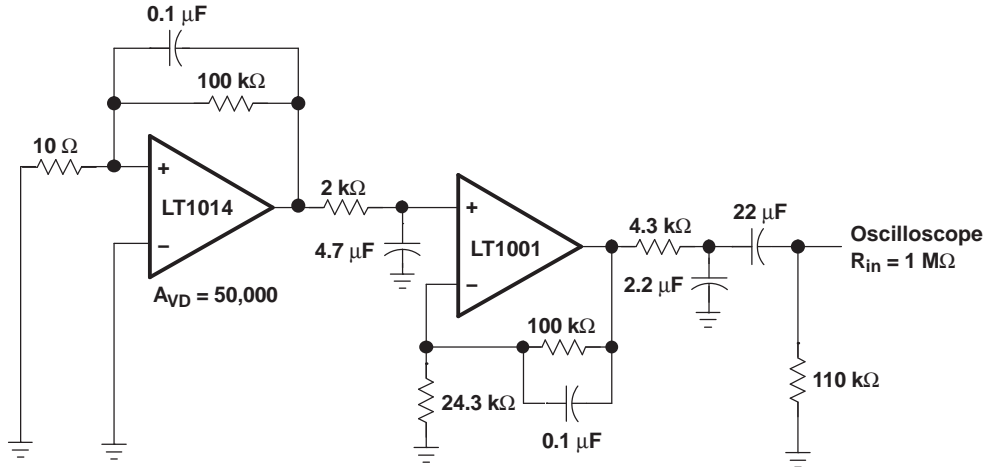

NOTE A: All capacitor values are for nonpolarized capacitors only.

Figure 28. 0.1-Hz to 10-Hz Peak-to-Peak Noise Test Circuit

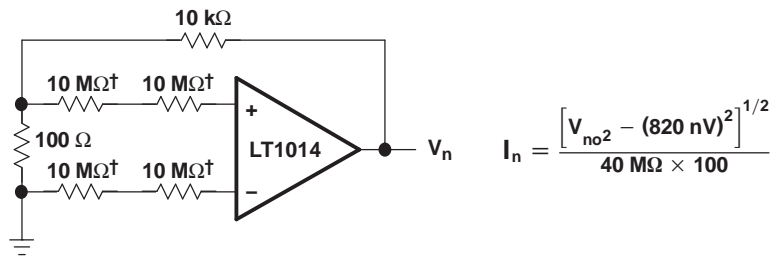

† Metal-film resistor

Figure 29. Noise-Current Test Circuit and Formula

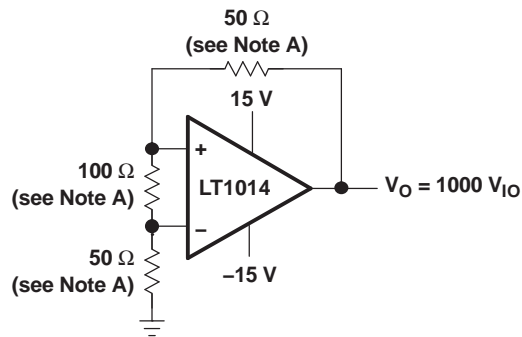

NOTE A: Resistors must have low thermoelectric potential.

Figure 30. Test Circuit for V_{IO} and αV_{IO}

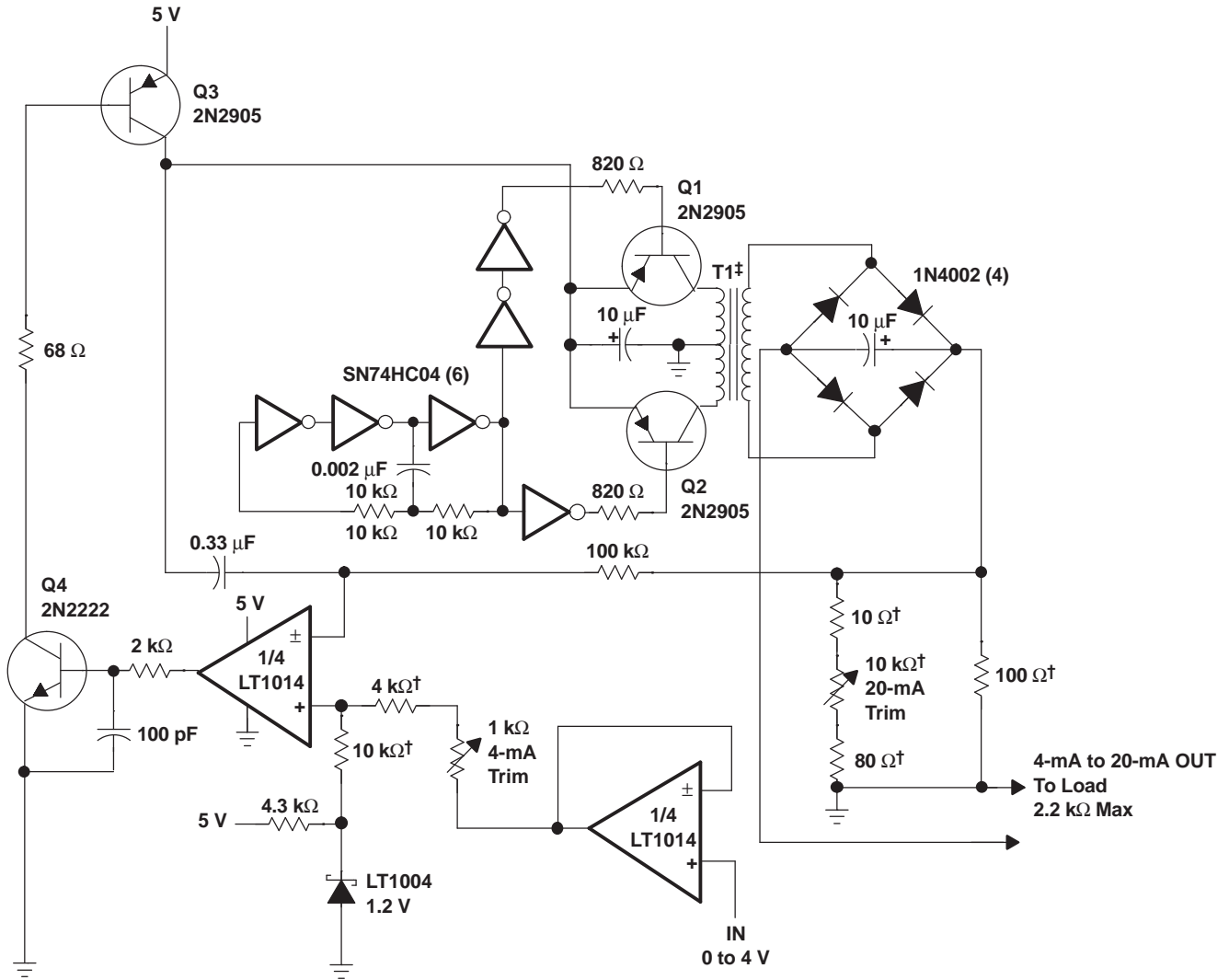

† 1% film resistor. Match 10-kΩ resistors 0.05%.
‡ T1 = PICO-31080

Figure 31. 5-V Powered, 4-mA to 20-mA Current-Loop Transmitter With 12-Bit Accuracy

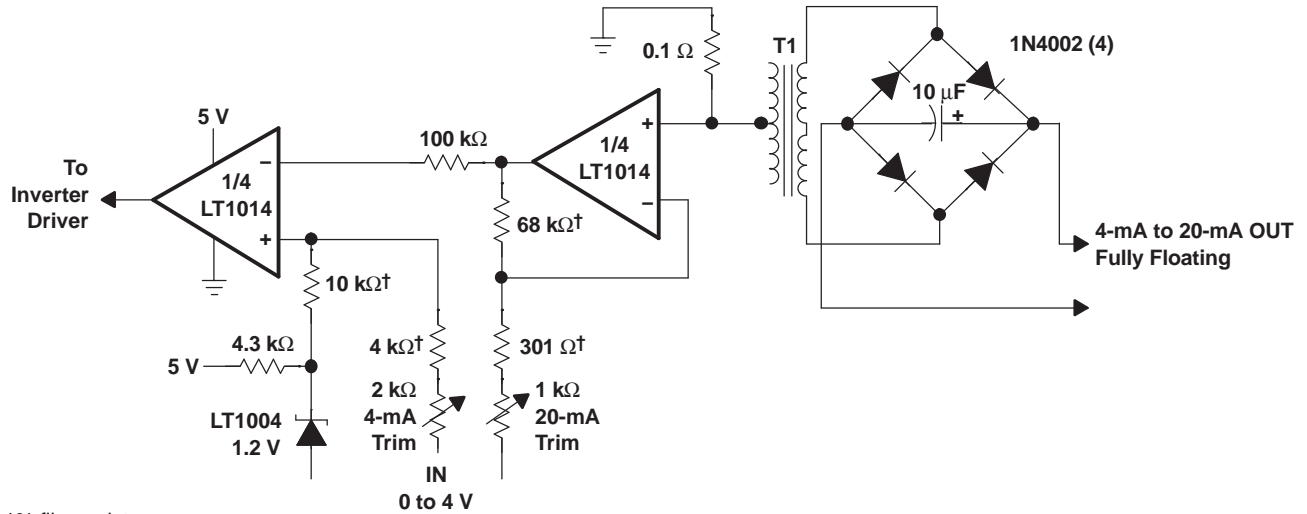

† 1% film resistor

Figure 32. Fully Floating Modification to 4-mA to 20-mA Current-Loop Transmitter With 8-Bit Accuracy

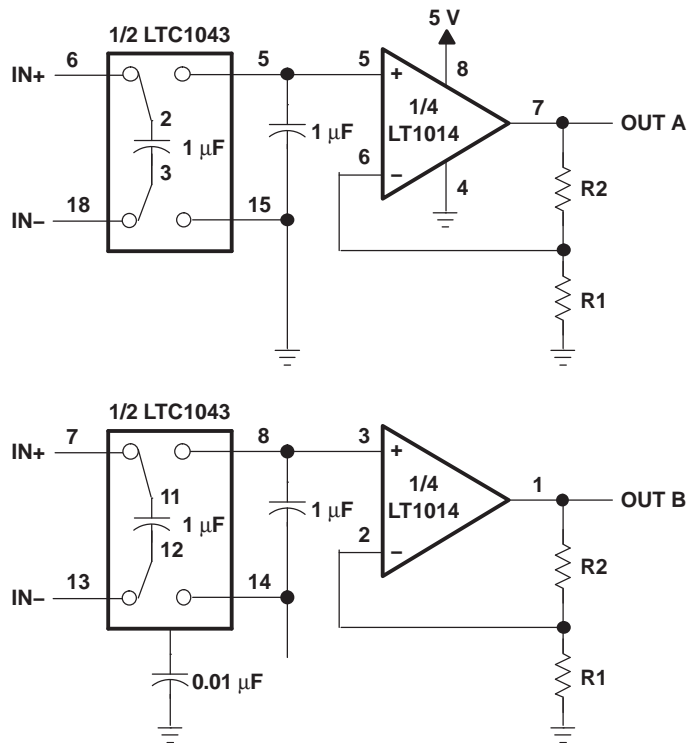

NOTE A: $V_{IO} = 150 \mu\text{V}$, $A_{VD} = (R1/R2) + 1$, $CMRR = 120 \text{ dB}$, $V_{ICR} = 0 \text{ to } 5 \text{ V}$

Figure 33. 5-V Single-Supply Dual Instrumentation Amplifier

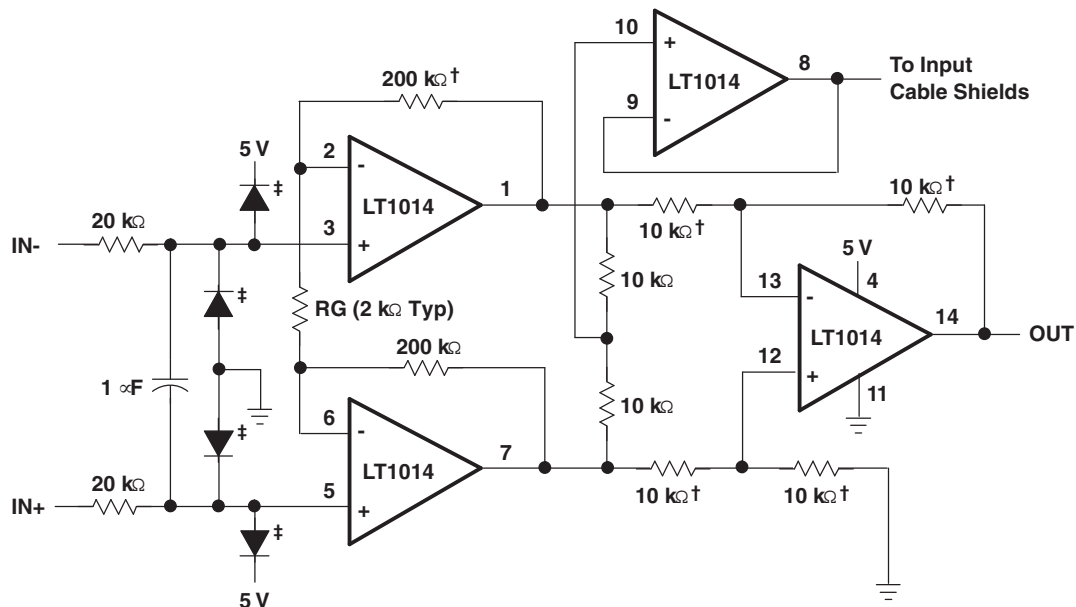

† 1% film resistor. Match 10-kΩ resistors 0.05%.

‡ For high source impedances, use 2N2222 as diodes (with collector connected to base).

NOTE A: $A_{VD} = (400,000/RG) + 1$

Figure 34. 5-V Powered Precision Instrumentation Amplifier

PACKAGING INFORMATION

Orderable Device	Status (1)	Package Type	Package Drawing	Pins	Package Qty	Eco Plan (2)	Lead/Ball Finish (6)	MSL Peak Temp (3)	Op Temp (°C)	Device Marking (4/5)	Samples
LT1014DMDWREP	ACTIVE	SOIC	DW	16	2000	Green (RoHS & no Sb/Br)	CU NIPDAU	Level-1-260C-UNLIM	-55 to 125	LT1014DMEP	Samples
V62/09614-01XE	ACTIVE	SOIC	DW	16	2000	Green (RoHS & no Sb/Br)	CU NIPDAU	Level-1-260C-UNLIM	-55 to 125	LT1014DMEP	Samples

(1) The marketing status values are defined as follows:

ACTIVE: Product device recommended for new designs.

LIFEBUY: TI has announced that the device will be discontinued, and a lifetime-buy period is in effect.

NRND: Not recommended for new designs. Device is in production to support existing customers, but TI does not recommend using this part in a new design.

PREVIEW: Device has been announced but is not in production. Samples may or may not be available.

OBSELETE: TI has discontinued the production of the device.

(2) Eco Plan - The planned eco-friendly classification: Pb-Free (RoHS), Pb-Free (RoHS Exempt), or Green (RoHS & no Sb/Br) - please check <http://www.ti.com/productcontent> for the latest availability information and additional product content details.

TBD: The Pb-Free/Green conversion plan has not been defined.

Pb-Free (RoHS): TI's terms "Lead-Free" or "Pb-Free" mean semiconductor products that are compatible with the current RoHS requirements for all 6 substances, including the requirement that lead not exceed 0.1% by weight in homogeneous materials. Where designed to be soldered at high temperatures, TI Pb-Free products are suitable for use in specified lead-free processes.

Pb-Free (RoHS Exempt): This component has a RoHS exemption for either 1) lead-based flip-chip solder bumps used between the die and package, or 2) lead-based die adhesive used between the die and leadframe. The component is otherwise considered Pb-Free (RoHS compatible) as defined above.

Green (RoHS & no Sb/Br): TI defines "Green" to mean Pb-Free (RoHS compatible), and free of Bromine (Br) and Antimony (Sb) based flame retardants (Br or Sb do not exceed 0.1% by weight in homogeneous material)

(3) MSL, Peak Temp. - The Moisture Sensitivity Level rating according to the JEDEC industry standard classifications, and peak solder temperature.

(4) There may be additional marking, which relates to the logo, the lot trace code information, or the environmental category on the device.

(5) Multiple Device Markings will be inside parentheses. Only one Device Marking contained in parentheses and separated by a "~" will appear on a device. If a line is indented then it is a continuation of the previous line and the two combined represent the entire Device Marking for that device.

(6) Lead/Ball Finish - Orderable Devices may have multiple material finish options. Finish options are separated by a vertical ruled line. Lead/Ball Finish values may wrap to two lines if the finish value exceeds the maximum column width.

Important Information and Disclaimer:The information provided on this page represents TI's knowledge and belief as of the date that it is provided. TI bases its knowledge and belief on information provided by third parties, and makes no representation or warranty as to the accuracy of such information. Efforts are underway to better integrate information from third parties. TI has taken and continues to take reasonable steps to provide representative and accurate information but may not have conducted destructive testing or chemical analysis on incoming materials and chemicals. TI and TI suppliers consider certain information to be proprietary, and thus CAS numbers and other limited information may not be available for release.

In no event shall TI's liability arising out of such information exceed the total purchase price of the TI part(s) at issue in this document sold by TI to Customer on an annual basis.

OTHER QUALIFIED VERSIONS OF LT1014D-EP :

- Catalog: [LT1014D](#)

NOTE: Qualified Version Definitions:

- Catalog - TI's standard catalog product

TAPE AND REEL INFORMATION



QUADRANT ASSIGNMENTS FOR PIN 1 ORIENTATION IN TAPE



*All dimensions are nominal

Device	Package Type	Package Drawing	Pins	SPQ	Reel Diameter (mm)	Reel Width W1 (mm)	A0 (mm)	B0 (mm)	K0 (mm)	P1 (mm)	W (mm)	Pin1 Quadrant
LT1014DMDWREP	SOIC	DW	16	2000	330.0	16.4	10.75	10.7	2.7	12.0	16.0	Q1

TAPE AND REEL BOX DIMENSIONS



*All dimensions are nominal

Device	Package Type	Package Drawing	Pins	SPQ	Length (mm)	Width (mm)	Height (mm)
LT1014DMDWREP	SOIC	DW	16	2000	350.0	350.0	43.0

GENERIC PACKAGE VIEW

DW 16

SOIC - 2.65 mm max height

7.5 x 10.3, 1.27 mm pitch

SMALL OUTLINE INTEGRATED CIRCUIT

This image is a representation of the package family, actual package may vary.
Refer to the product data sheet for package details.

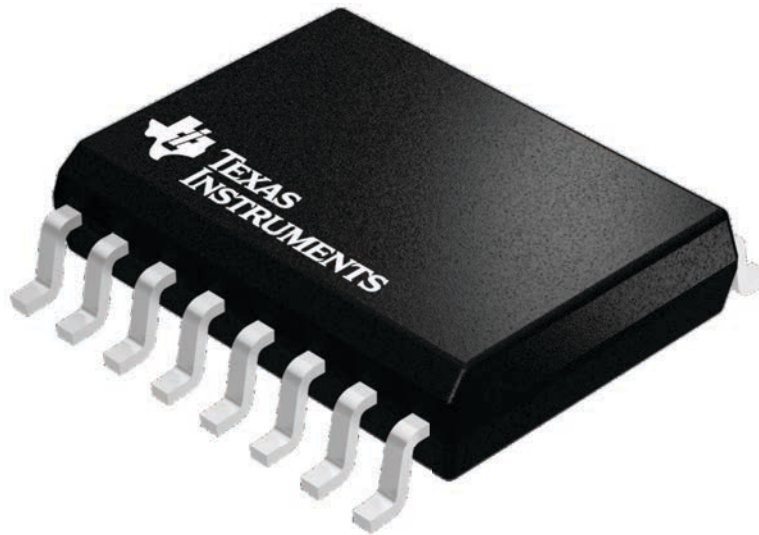

4224780/A



DW0016A

PACKAGE OUTLINE SOIC - 2.65 mm max height

SOIC

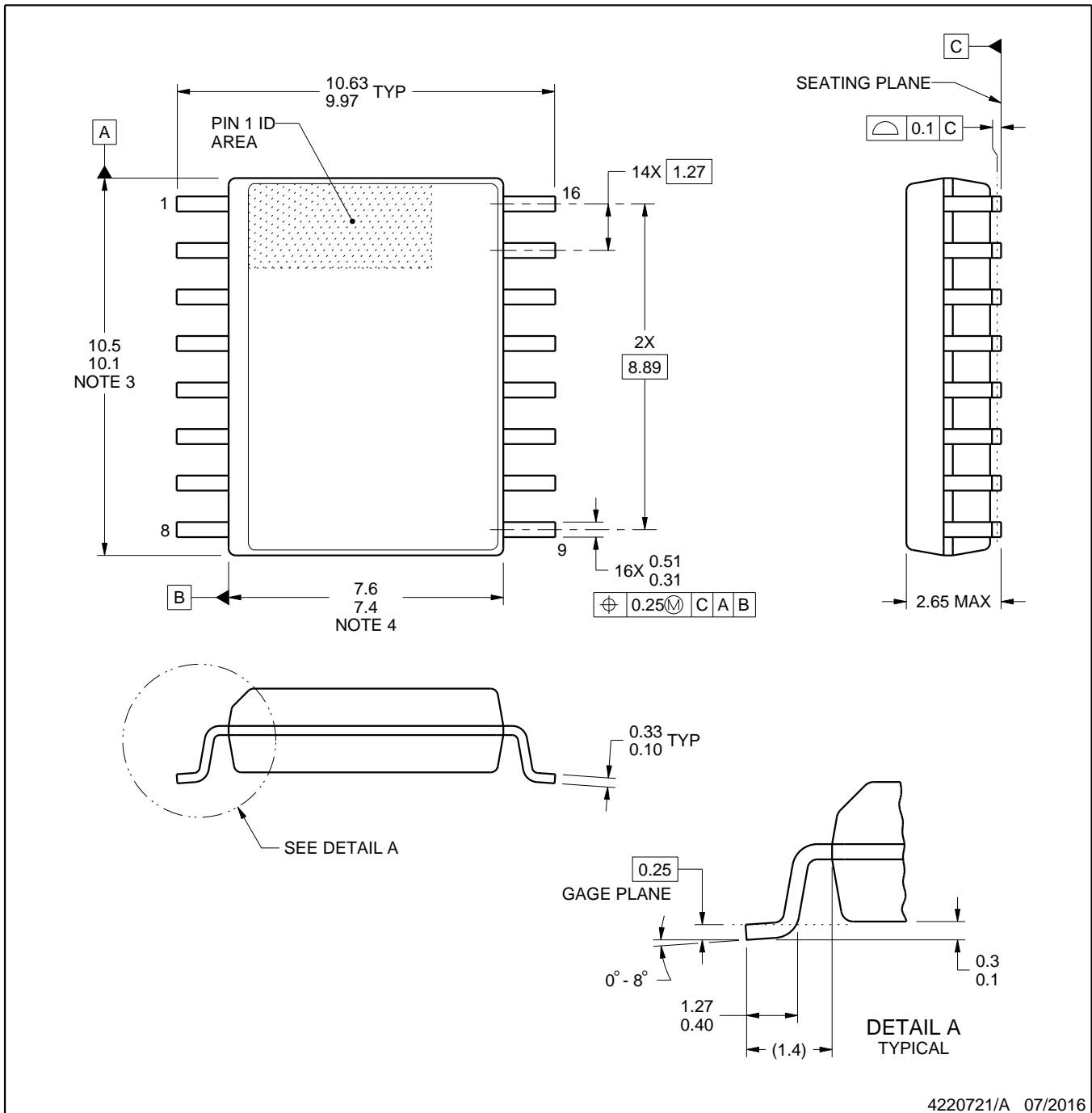

4220721/A 07/2016

NOTES:

1. All linear dimensions are in millimeters. Dimensions in parenthesis are for reference only. Dimensioning and tolerancing per ASME Y14.5M.
2. This drawing is subject to change without notice.
3. This dimension does not include mold flash, protrusions, or gate burrs. Mold flash, protrusions, or gate burrs shall not exceed 0.15 mm, per side.
4. This dimension does not include interlead flash. Interlead flash shall not exceed 0.25 mm, per side.
5. Reference JEDEC registration MS-013.

EXAMPLE BOARD LAYOUT

DW0016A

SOIC - 2.65 mm max height

SOIC

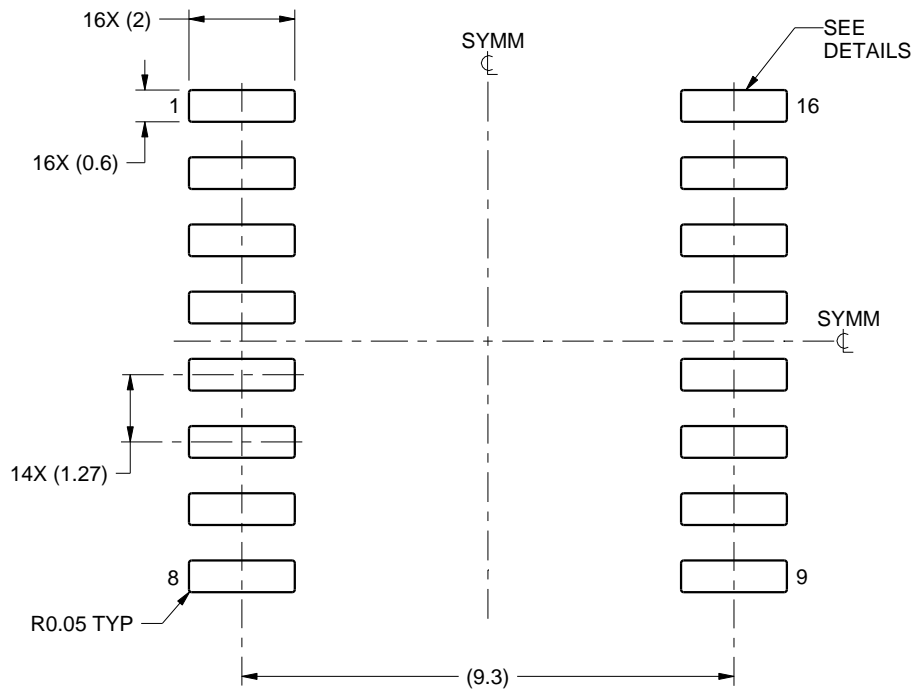

LAND PATTERN EXAMPLE
SCALE:7X



SOLDER MASK DETAILS

4220721/A 07/2016

NOTES: (continued)

6. Publication IPC-7351 may have alternate designs.

7. Solder mask tolerances between and around signal pads can vary based on board fabrication site.

EXAMPLE STENCIL DESIGN

DW0016A

SOIC - 2.65 mm max height

SOIC

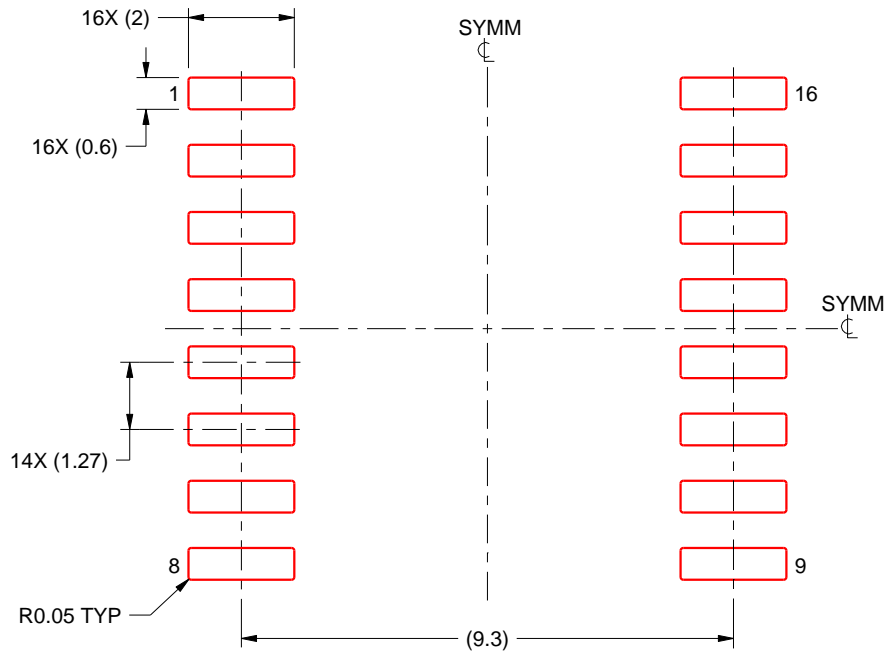

SOLDER PASTE EXAMPLE
BASED ON 0.125 mm THICK STENCIL
SCALE:7X

4220721/A 07/2016

NOTES: (continued)

8. Laser cutting apertures with trapezoidal walls and rounded corners may offer better paste release. IPC-7525 may have alternate design recommendations.
9. Board assembly site may have different recommendations for stencil design.

IMPORTANT NOTICE AND DISCLAIMER

TI PROVIDES TECHNICAL AND RELIABILITY DATA (INCLUDING DATASHEETS), DESIGN RESOURCES (INCLUDING REFERENCE DESIGNS), APPLICATION OR OTHER DESIGN ADVICE, WEB TOOLS, SAFETY INFORMATION, AND OTHER RESOURCES "AS IS" AND WITH ALL FAULTS, AND DISCLAIMS ALL WARRANTIES, EXPRESS AND IMPLIED, INCLUDING WITHOUT LIMITATION ANY IMPLIED WARRANTIES OF MERCHANTABILITY, FITNESS FOR A PARTICULAR PURPOSE OR NON-INFRINGEMENT OF THIRD PARTY INTELLECTUAL PROPERTY RIGHTS.



These resources are intended for skilled developers designing with TI products. You are solely responsible for (1) selecting the appropriate TI products for your application, (2) designing, validating and testing your application, and (3) ensuring your application meets applicable standards, and any other safety, security, or other requirements. These resources are subject to change without notice. TI grants you permission to use these resources only for development of an application that uses the TI products described in the resource. Other reproduction and display of these resources is prohibited. No license is granted to any other TI intellectual property right or to any third party intellectual property right. TI disclaims responsibility for, and you will fully indemnify TI and its representatives against, any claims, damages, costs, losses, and liabilities arising out of your use of these resources.

TI's products are provided subject to TI's Terms of Sale (www.ti.com/legal/termsofsale.html) or other applicable terms available either on ti.com or provided in conjunction with such TI products. TI's provision of these resources does not expand or otherwise alter TI's applicable warranties or warranty disclaimers for TI products.

Mailing Address: Texas Instruments, Post Office Box 655303, Dallas, Texas 75265
Copyright © 2019, Texas Instruments Incorporated

Looking for pricing, stock, or lifecycle information?

Click below to explore more details on WIN SOURCE:

-  [View LT1014DMDWREP](#) on WIN SOURCE
-  [Texas Instruments](#) Information

Optimize Your Supply Chain with WIN SOURCE Solutions

-  Global Sourcing Solution
-  Obsolete Management
-  Cost Control Management
-  Shortage Management
-  Alternative Solution
-  Excess Inventory Management