



# MC14585B

## 4-Bit Magnitude Comparator

The MC14585B 4-Bit Magnitude Comparator is constructed with complementary MOS (CMOS) enhancement mode devices. The circuit has eight comparing inputs (A3, B3, A2, B2, A1, B1, A0, B0), three cascading inputs (A < B, A = B, and A > B), and three outputs (A < B, A = B, and A > B). This device compares two 4-bit words (A and B) and determines whether they are “less than”, “equal to”, or “greater than” by a high level on the appropriate output. For words greater than 4-bits, units can be cascaded by connecting outputs (A > B), (A < B), and (A = B) to the corresponding inputs of the next significant comparator. Inputs (A < B), (A = B), and (A > B) on the least significant (first) comparator are connected to a low, a high, and a low, respectively.

Applications include logic in CPU's, correction and/or detection of instrumentation conditions, comparator in testers, converters, and controls.

### Features

- Diode Protection on All Inputs
- Expandable
- Applicable to Binary or 8421-BCD Code
- Supply Voltage Range = 3.0 Vdc to 18 Vdc
- Capable of Driving Two Low-Power TTL Loads or One Low-Power Schottky TTL Load over the Rated Temperature Range
- Can be Cascaded – See Figure 3
- NLV Prefix for Automotive and Other Applications Requiring Unique Site and Control Change Requirements; AEC-Q100 Qualified and PPAP Capable\*
- This Device is Pb-Free and is RoHS Compliant

### MAXIMUM RATINGS (Voltages Referenced to V<sub>SS</sub>)

Parameter	Symbol	Value	Unit
DC Supply Voltage Range	V <sub>DD</sub>	-0.5 to +18.0	V
Input or Output Voltage Range (DC or Transient)	V <sub>in</sub> , V <sub>out</sub>	-0.5 to V <sub>DD</sub> + 0.5	V
Input or Output Current (DC or Transient) per Pin	I <sub>in</sub> , I <sub>out</sub>	±10	mA
Power Dissipation per Package (Note 1)	P <sub>D</sub>	500	mW
Ambient Temperature Range	T <sub>A</sub>	-55 to +125	°C
Storage Temperature Range	T <sub>stg</sub>	-65 to +150	°C
Lead Temperature (8-Second Soldering)	T <sub>L</sub>	260	°C

Stresses exceeding those listed in the Maximum Ratings table may damage the device. If any of these limits are exceeded, device functionality should not be assumed, damage may occur and reliability may be affected.

1. Temperature Derating: “D/DW” Package: -7.0 mW/°C From 65°C To 125°C

This device contains protection circuitry to guard against damage due to high static voltages or electric fields. However, precautions must be taken to avoid applications of any voltage higher than maximum rated voltages to this high-impedance circuit. For proper operation, V<sub>in</sub> and V<sub>out</sub> should be constrained to the range V<sub>SS</sub> ≤ (V<sub>in</sub> or V<sub>out</sub>) ≤ V<sub>DD</sub>.

Unused inputs must always be tied to an appropriate logic voltage level (e.g., either V<sub>SS</sub> or V<sub>DD</sub>). Unused outputs must be left open.



ON Semiconductor®

<http://onsemi.com>

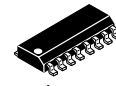

1  
SOIC-16  
D SUFFIX  
CASE 751B

### PIN ASSIGNMENT

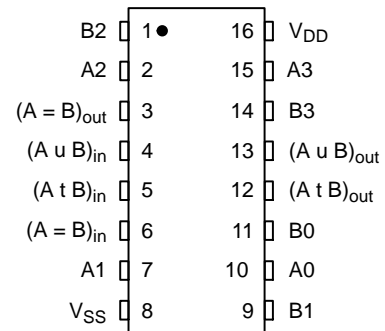

### MARKING DIAGRAM

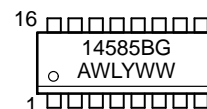

A = Assembly Location  
WL, L = Wafer Lot  
YY, Y = Year  
WW, W = Work Week  
G = Pb-Free Package

### ORDERING INFORMATION

Device	Package	Shipping†
MC14585BDG	SOIC-16 (Pb-Free)	48 Units / Rail
MC14585BDR2G	SOIC-16 (Pb-Free)	2500/Tape & Reel
NLV14585BDR2G*	SOIC-16 (Pb-Free)	2500/Tape & Reel

†For information on tape and reel specifications, including part orientation and tape sizes, please refer to our Tape and Reel Packaging Specifications Brochure, BRD8011/D.

# MC14585B

## BLOCK DIAGRAM

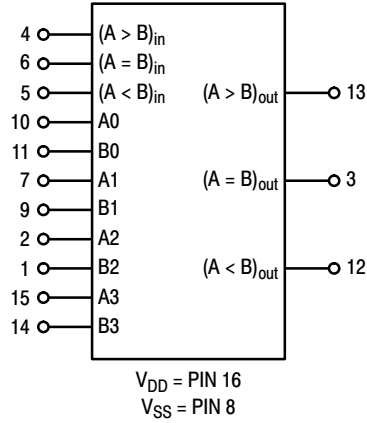

**TRUTH TABLE** (x = Don't Care)

Inputs							Outputs		
Comparing				Cascading					
A3, B3	A2, B2	A1, B1	A0, B0	A < B	A = B	A > B	A < B	A = B	A > B
A3 > B3	x	x	x	x	x	x	0	0	1
A3 = B3	A2 > B2	x	x	x	x	x	0	0	1
A3 = B3	A2 = B2	A1 > B1	x	x	x	x	0	0	1
A3 = B3	A2 = B2	A1 = B1	A0 > B0	x	x	x	0	0	1
A3 = B3	A2 = B2	A1 = B1	A0 = B0	0	0	x	0	0	1
A3 = B3	A2 = B2	A1 = B1	A0 = B0	0	1	x	0	1	0
A3 = B3	A2 = B2	A1 = B1	A0 = B0	1	0	x	1	0	0
A3 = B3	A2 = B2	A1 = B1	A0 = B0	1	1	x	1	1	0
A3 = B3	A2 = B2	A1 = B1	A0 < B0	x	x	x	1	0	0
A3 = B3	A2 = B2	A1 < B1	x	x	x	x	1	0	0
A3 = B3	A2 < B2	x	x	x	x	x	1	0	0
A3 < B3	x	x	x	x	x	x	1	0	0

# MC14585B

## ELECTRICAL CHARACTERISTICS (Voltages Referenced to V<sub>SS</sub>)

Characteristic	Symbol	V <sub>DD</sub> Vdc	-55°C		25°C			125°C		Unit	
			Min	Max	Min	Typ (Note 2)	Max	Min	Max		
Output Voltage V <sub>in</sub> = V <sub>DD</sub> or 0	“0” Level V <sub>OL</sub>	5.0	–	0.05	–	0	0.05	–	0.05	Vdc	
		10	–	0.05	–	0	0.05	–	0.05		
		15	–	0.05	–	0	0.05	–	0.05		
	“1” Level V <sub>in</sub> = 0 or V <sub>DD</sub>	V <sub>OH</sub>	5.0	4.95	–	4.95	5.0	–	4.95	–	Vdc
			10	9.95	–	9.95	10	–	9.95	–	
			15	14.95	–	14.95	15	–	14.95	–	
Input Voltage (V <sub>O</sub> = 4.5 or 0.5 Vdc) (V <sub>O</sub> = 9.0 or 1.0 Vdc) (V <sub>O</sub> = 13.5 or 1.5 Vdc)	“0” Level V <sub>IL</sub>	5.0	–	1.5	–	2.25	1.5	–	1.5	Vdc	
		10	–	3.0	–	4.50	3.0	–	3.0		
		15	–	4.0	–	6.75	4.0	–	4.0		
	“1” Level (V <sub>O</sub> = 0.5 or 4.5 Vdc) (V <sub>O</sub> = 1.0 or 9.0 Vdc) (V <sub>O</sub> = 1.5 or 13.5 Vdc)	V <sub>IH</sub>	5.0	3.5	–	3.5	2.75	–	3.5	–	Vdc
			10	7.0	–	7.0	5.50	–	7.0	–	
			15	11	–	11	8.25	–	11	–	
Output Drive Current (V <sub>OH</sub> = 2.5 Vdc) (V <sub>OH</sub> = 4.6 Vdc) (V <sub>OH</sub> = 9.5 Vdc) (V <sub>OH</sub> = 13.5 Vdc)	Source I <sub>OH</sub>	5.0	–3.0	–	–2.4	–4.2	–	–1.7	–	mAdc	
		5.0	–0.64	–	–0.51	–0.88	–	–0.36	–		
		10	–1.6	–	–1.3	–2.25	–	–0.9	–		
		15	–4.2	–	–3.4	–8.8	–	–2.4	–		
	Sink (V <sub>OL</sub> = 0.4 Vdc) (V <sub>OL</sub> = 0.5 Vdc) (V <sub>OL</sub> = 1.5 Vdc)	I <sub>OL</sub>	5.0	0.64	–	0.51	0.88	–	0.36	–	mAdc
			10	1.6	–	1.3	2.25	–	0.9	–	
15	4.2	–	3.4	8.8	–	2.4	–	–	–		
Input Current	I <sub>in</sub>	15	–	±0.1	–	±0.00001	±0.1	–	±1.0	μAdc	
Input Capacitance (V <sub>in</sub> = 0)	C <sub>in</sub>	–	–	–	–	5.0	7.5	–	–	pF	
Quiescent Current (Per Package)	I <sub>DD</sub>	5.0	–	5.0	–	0.005	5.0	–	150	μAdc	
		10	–	10	–	0.010	10	–	300		
		15	–	20	–	0.015	20	–	600		
Total Supply Current (Notes 3, 4) (Dynamic plus Quiescent, Per Package) (C <sub>L</sub> = 50 pF on all outputs, all buffers switching)	I <sub>T</sub>	5.0 10 15	I <sub>T</sub> = (0.6 μA/kHz) f + I <sub>DD</sub> I <sub>T</sub> = (1.2 μA/kHz) f + I <sub>DD</sub> I <sub>T</sub> = (1.8 μA/kHz) f + I <sub>DD</sub>						μAdc		

Product parametric performance is indicated in the Electrical Characteristics for the listed test conditions, unless otherwise noted. Product performance may not be indicated by the Electrical Characteristics if operated under different conditions.

2. Data labelled “Typ” is not to be used for design purposes but is intended as an indication of the IC’s potential performance.

3. The formulas given are for the typical characteristics only at 25°C.

4. To calculate total supply current at loads other than 50 pF: I<sub>T</sub>(C<sub>L</sub>) = I<sub>T</sub>(50 pF) + (C<sub>L</sub> – 50) Vfk where: I<sub>T</sub> is in μA (per package), C<sub>L</sub> in pF, V = (V<sub>DD</sub> – V<sub>SS</sub>) in volts, f in kHz is input frequency, and k = 0.001.

## SWITCHING CHARACTERISTICS (Note 5) (C<sub>L</sub> = 50 pF, T<sub>A</sub> = 25°C)

Characteristic	Symbol	V <sub>DD</sub>	Min	Typ (Note 6)	Max	Unit
Output Rise and Fall Time t <sub>TLH</sub> , t <sub>THL</sub> = (1.5 ns/pF) C <sub>L</sub> + 25 ns t <sub>TLH</sub> , t <sub>THL</sub> = (0.75 ns/pF) C <sub>L</sub> + 12.5 ns t <sub>TLH</sub> , t <sub>THL</sub> = (0.55 ns/pF) C <sub>L</sub> + 9.5 ns	t <sub>TLH</sub> , t <sub>THL</sub>	5.0	–	100	200	ns
		10	–	50	100	
		15	–	40	80	
		–	–	–	–	
Turn-On, Turn-Off Delay Time t <sub>PLH</sub> , t <sub>PHL</sub> = (1.7 ns/pF) C <sub>L</sub> + 345 ns t <sub>PLH</sub> , t <sub>PHL</sub> = (0.66 ns/pF) C <sub>L</sub> + 147 ns t <sub>PLH</sub> , t <sub>PHL</sub> = (0.5 ns/pF) C <sub>L</sub> + 105 ns	t <sub>PLH</sub> , t <sub>PHL</sub>	5.0	–	430	860	ns
		10	–	180	360	
		15	–	130	260	
		–	–	–	–	

5. The formulas given are for the typical characteristics only at 25°C.

6. Data labelled “Typ” is not to be used for design purposes but is intended as an indication of the IC’s potential performance.

# MC14585B

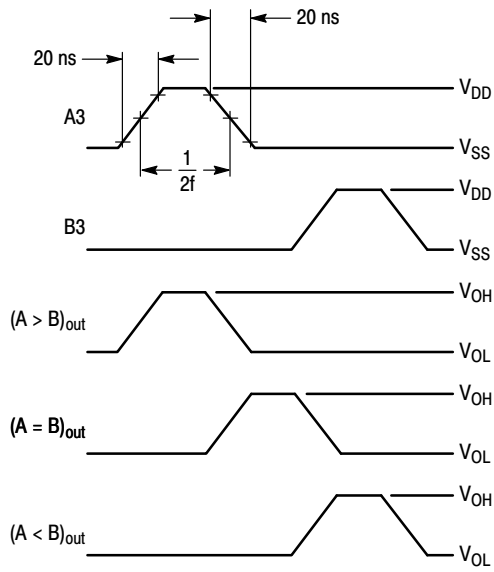

Inputs (A>B) and (A=B) high, and inputs B2, A2, B1, A1, B0, A0 and (A<B) low.  
f in respect to a system clock.

**Figure 1. Dynamic Power Dissipation Signal Waveforms**

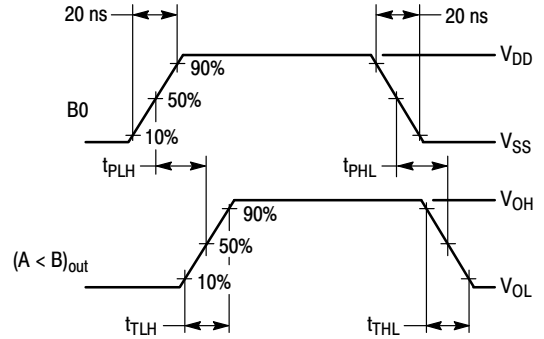

Inputs (A>B) and (A=B) high, and inputs B3, A3, B2, A2, B1, A1, A0, and (A<B) low.

**Figure 2. Dynamic Signal Waveforms**

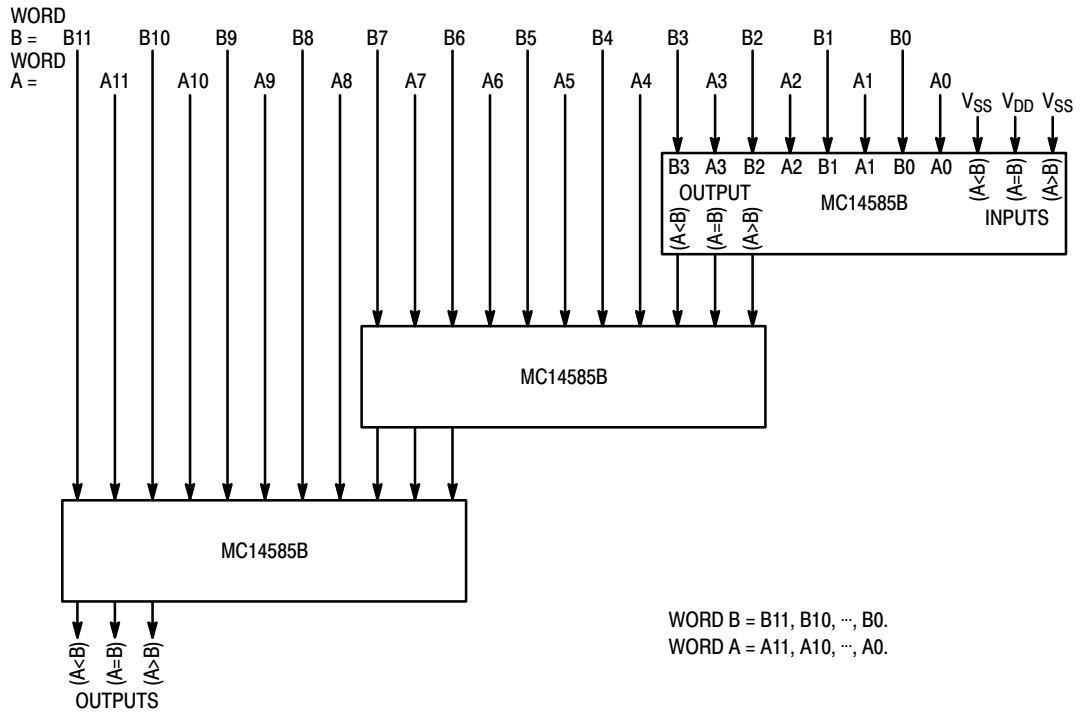

**Figure 3. Cascading Comparators**

# MC14585B

## LOGIC DIAGRAM

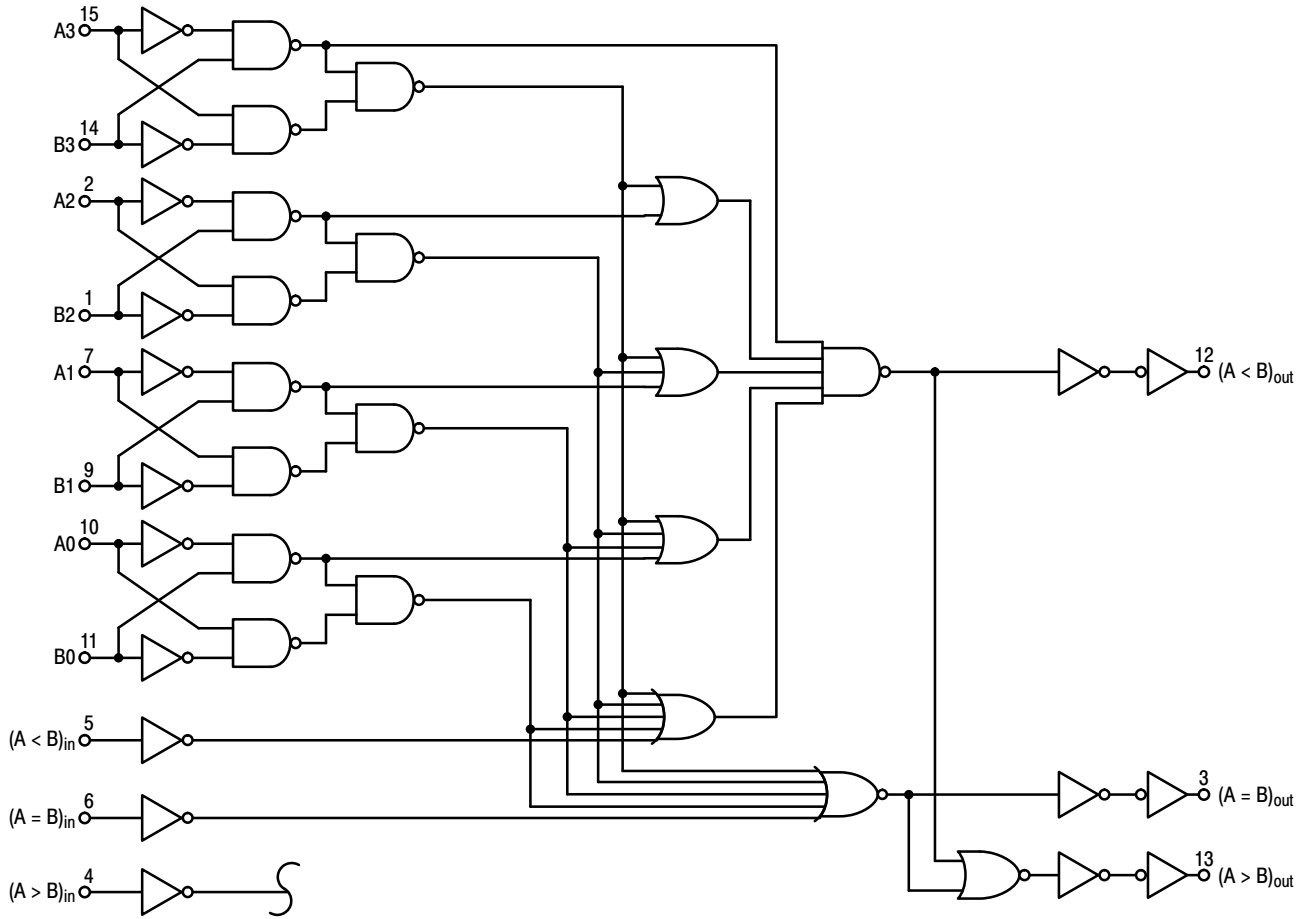

# MC14585B

## PACKAGE DIMENSIONS

SOIC-16  
CASE 751B-05  
ISSUE K

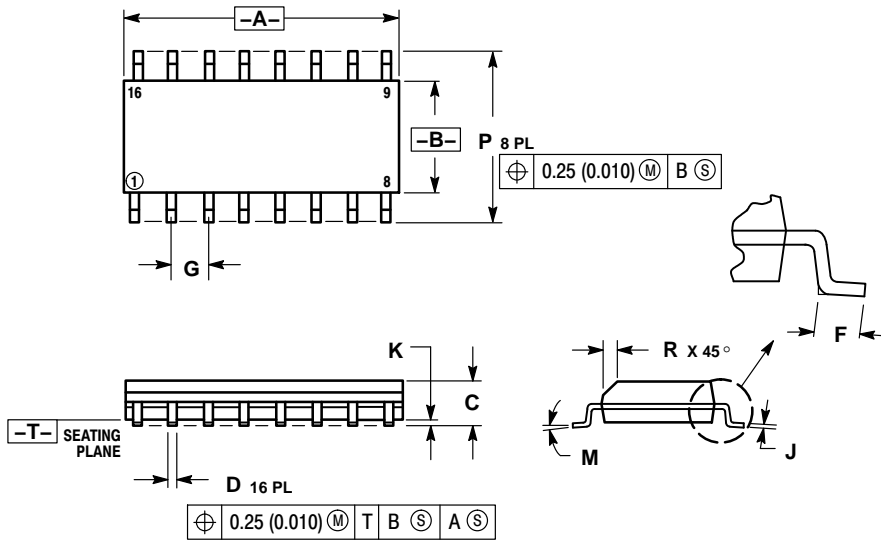



### NOTES:

1. DIMENSIONING AND TOLERANCING PER ANSI Y14.5M, 1982.
2. CONTROLLING DIMENSION: MILLIMETER.
3. DIMENSIONS A AND B DO NOT INCLUDE MOLD PROTRUSION.
4. MAXIMUM MOLD PROTRUSION 0.15 (0.006) PER SIDE.
5. DIMENSION D DOES NOT INCLUDE DAMBAR PROTRUSION. ALLOWABLE DAMBAR PROTRUSION SHALL BE 0.127 (0.005) TOTAL IN EXCESS OF THE D DIMENSION AT MAXIMUM MATERIAL CONDITION.

DIM	MILLIMETERS		INCHES	
	MIN	MAX	MIN	MAX
A	9.80	10.00	0.386	0.393
B	3.80	4.00	0.150	0.157
C	1.35	1.75	0.054	0.068
D	0.35	0.49	0.014	0.019
F	0.40	1.25	0.016	0.049
G	1.27 BSC		0.050 BSC	
J	0.19	0.25	0.008	0.009
K	0.10	0.25	0.004	0.009
M	0°	7°	0°	7°
P	5.80	6.20	0.229	0.244
R	0.25	0.50	0.010	0.019

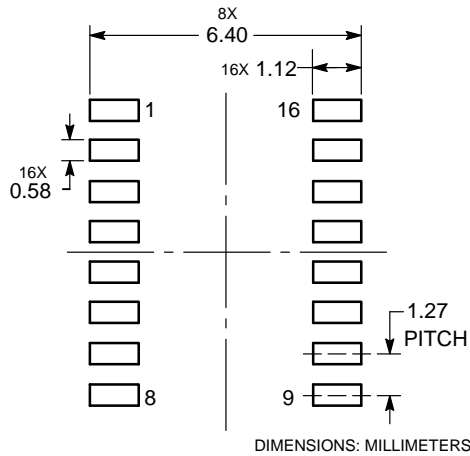
### SOLDERING FOOTPRINT



ON Semiconductor and the  are registered trademarks of Semiconductor Components Industries, LLC (SCILLC) or its subsidiaries in the United States and/or other countries. SCILLC owns the rights to a number of patents, trademarks, copyrights, trade secrets, and other intellectual property. A listing of SCILLC's product/patent coverage may be accessed at [www.onsemi.com/site/pdf/Patent-Marking.pdf](http://www.onsemi.com/site/pdf/Patent-Marking.pdf). SCILLC reserves the right to make changes without further notice to any products herein. SCILLC makes no warranty, representation or guarantee regarding the suitability of its products for any particular purpose, nor does SCILLC assume any liability arising out of the application or use of any product or circuit, and specifically disclaims any and all liability, including without limitation special, consequential or incidental damages. "Typical" parameters which may be provided in SCILLC data sheets and/or specifications can and do vary in different applications and actual performance may vary over time. All operating parameters, including "Typicals" must be validated for each customer application by customer's technical experts. SCILLC does not convey any license under its patent rights nor the rights of others. SCILLC products are not designed, intended, or authorized for use as components in systems intended for surgical implant into the body, or other applications intended to support or sustain life, or for any other application in which the failure of the SCILLC product could create a situation where personal injury or death may occur. Should Buyer purchase or use SCILLC products for any such unintended or unauthorized application, Buyer shall indemnify and hold SCILLC and its officers, employees, subsidiaries, affiliates, and distributors harmless against all claims, costs, damages, and expenses, and reasonable attorney fees arising out of, directly or indirectly, any claim of personal injury or death associated with such unintended or unauthorized use, even if such claim alleges that SCILLC was negligent regarding the design or manufacture of the part. SCILLC is an Equal Opportunity/Affirmative Action Employer. This literature is subject to all applicable copyright laws and is not for resale in any manner.

### PUBLICATION ORDERING INFORMATION

#### LITERATURE FULFILLMENT:

Literature Distribution Center for ON Semiconductor  
P.O. Box 5163, Denver, Colorado 80217 USA  
Phone: 303-675-2175 or 800-344-3860 Toll Free USA/Canada  
Fax: 303-675-2176 or 800-344-3867 Toll Free USA/Canada  
Email: [orderlit@onsemi.com](mailto:orderlit@onsemi.com)

N. American Technical Support: 800-282-9855 Toll Free  
USA/Canada  
Europe, Middle East and Africa Technical Support:  
Phone: 421 33 790 2910  
Japan Customer Focus Center  
Phone: 81-3-5817-1050

ON Semiconductor Website: [www.onsemi.com](http://www.onsemi.com)

Order Literature: <http://www.onsemi.com/orderlit>

For additional information, please contact your local Sales Representative

## Looking for pricing, stock, or lifecycle information?

Click below to explore more details on WIN SOURCE:

 [View MC14585BDR2G on WIN SOURCE](#)

 [ON Semiconductor](#) Information

## Optimize Your Supply Chain with WIN SOURCE Solutions

-  Global Sourcing Solution
-  Obsolete Management
-  Cost Control Management
-  Shortage Management
-  Alternative Solution
-  Excess Inventory Management