



MCP1631HV
Multi-Chemistry
Battery Charger
Reference Design

Note the following details of the code protection feature on Microchip devices:

- Microchip products meet the specification contained in their particular Microchip Data Sheet.
- Microchip believes that its family of products is one of the most secure families of its kind on the market today, when used in the intended manner and under normal conditions.
- There are dishonest and possibly illegal methods used to breach the code protection feature. All of these methods, to our knowledge, require using the Microchip products in a manner outside the operating specifications contained in Microchip's Data Sheets. Most likely, the person doing so is engaged in theft of intellectual property.
- Microchip is willing to work with the customer who is concerned about the integrity of their code.
- Neither Microchip nor any other semiconductor manufacturer can guarantee the security of their code. Code protection does not mean that we are guaranteeing the product as "unbreakable."

Code protection is constantly evolving. We at Microchip are committed to continuously improving the code protection features of our products. Attempts to break Microchip's code protection feature may be a violation of the Digital Millennium Copyright Act. If such acts allow unauthorized access to your software or other copyrighted work, you may have a right to sue for relief under that Act.

Information contained in this publication regarding device applications and the like is provided only for your convenience and may be superseded by updates. It is your responsibility to ensure that your application meets with your specifications. MICROCHIP MAKES NO REPRESENTATIONS OR WARRANTIES OF ANY KIND WHETHER EXPRESS OR IMPLIED, WRITTEN OR ORAL, STATUTORY OR OTHERWISE, RELATED TO THE INFORMATION, INCLUDING BUT NOT LIMITED TO ITS CONDITION, QUALITY, PERFORMANCE, MERCHANTABILITY OR FITNESS FOR PURPOSE. Microchip disclaims all liability arising from this information and its use. Use of Microchip devices in life support and/or safety applications is entirely at the buyer's risk, and the buyer agrees to defend, indemnify and hold harmless Microchip from any and all damages, claims, suits, or expenses resulting from such use. No licenses are conveyed, implicitly or otherwise, under any Microchip intellectual property rights.

Trademarks

The Microchip name and logo, the Microchip logo, Accuron, dsPIC, KEELOQ, KEELOQ logo, MPLAB, PIC, PICmicro, PICSTART, rPIC, SmartShunt and UNI/O are registered trademarks of Microchip Technology Incorporated in the U.S.A. and other countries.

FilterLab, Linear Active Thermistor, MXDEV, MXLAB, SEEVAL, SmartSensor and The Embedded Control Solutions Company are registered trademarks of Microchip Technology Incorporated in the U.S.A.

Analog-for-the-Digital Age, Application Maestro, CodeGuard, dsPICDEM, dsPICDEM.net, dsPICworks, dsSPEAK, ECAN, ECONOMONITOR, FanSense, In-Circuit Serial Programming, ICSP, ICEPIC, Mindi, MiWi, MPASM, MPLAB Certified logo, MPLIB, MPLINK, mTouch, PICkit, PICDEM, PICDEM.net, PICTail, PIC³² logo, PowerCal, PowerInfo, PowerMate, PowerTool, REAL ICE, rLAB, Select Mode, Total Endurance, WiperLock and ZENA are trademarks of Microchip Technology Incorporated in the U.S.A. and other countries.

SQTP is a service mark of Microchip Technology Incorporated in the U.S.A.

All other trademarks mentioned herein are property of their respective companies.

© 2009, Microchip Technology Incorporated, Printed in the U.S.A., All Rights Reserved.

 Printed on recycled paper.

QUALITY MANAGEMENT SYSTEM
CERTIFIED BY DNV
== ISO/TS 16949:2002 ==

Microchip received ISO/TS-16949:2002 certification for its worldwide headquarters, design and wafer fabrication facilities in Chandler and Tempe, Arizona; Gresham, Oregon and design centers in California and India. The Company's quality system processes and procedures are for its PIC[®] MCUs and dsPIC[®] DSCs, KEELOQ[®] code hopping devices, Serial EEPROMs, microperipherals, nonvolatile memory and analog products. In addition, Microchip's quality system for the design and manufacture of development systems is ISO 9001:2000 certified.



MCP1631HV MULTI-CHEMISTRY BATTERY CHARGER REFERENCE DESIGN

Table of Contents

Preface	1
Introduction.....	1
Document Layout	1
Conventions Used in this Guide	2
Recommended Reading.....	3
The Microchip Web Site	3
Customer Support	3
Document Revision History	3
Chapter 1. Product Overview	
1.1 Introduction	5
1.2 What is the MCP1631HV Multi-Chemistry Battery Charger Reference Design?	6
1.3 What the MCP1631HV Multi-Chemistry Battery Charger Reference Design kit includes	6
Chapter 2. Installation and Operation	
2.1 Introduction	7
2.2 Features	7
2.3 Getting Started	7
Appendix A. Schematic and Layout	
A.1 Introduction	13
A.2 Board – Schematic	14
A.3 Board – Top Silk Layer	15
A.4 Board – Bottom Silk Layer	16
A.5 Board – Top Metal Layer	17
A.6 Board – Mid1 Metal Layer	18
A.7 Board – Mid2 Metal Layer	19
A.8 Board – Bottom Metal Layer	20
Appendix B. Bill Of Materials (BOM)	
Appendix C. Software	
C.1 Device SOFTWARE Flowchart	23
C.2 Selected Software Constants and Definitions	34
C.3 PIC16F883 Port Usage	37
C.4 mikroElektronika's mikroC™ Compiler Startup	38
C.5 MPLAB® and PICKIT™ 2 Debugging Exercise	39
C.6 Lab Exercises	40

MCP1631HV Multi-Chemistry Battery Charger Reference Design

Appendix D. Design Example

D.1 Design Example 47

Worldwide Sales and Service50



MCP1631HV MULTI-CHEMISTRY BATTERY CHARGER REFERENCE DESIGN

Preface

NOTICE TO CUSTOMERS

All documentation becomes dated, and this manual is no exception. Microchip tools and documentation are constantly evolving to meet customer needs, so some actual dialogs and/or tool descriptions may differ from those in this document. Please refer to our web site (www.microchip.com) to obtain the latest documentation available.

Documents are identified with a “DS” number. This number is located on the bottom of each page, in front of the page number. The numbering convention for the DS number is “DSXXXXA”, where “XXXX” is the document number and “A” is the revision level of the document.

For the most up-to-date information on development tools, see the MPLAB® IDE on-line help. Select the Help menu, and then Topics to open a list of available on-line help files.

INTRODUCTION

This chapter contains general information that will be useful to know before using the MCP1631HV Multi-Chemistry Battery Charger Reference Design. Items discussed in this chapter include:

- Document Layout
- Conventions Used in this Guide
- Recommended Reading
- The Microchip Web Site
- Customer Support
- Document Revision History

DOCUMENT LAYOUT

This document describes how to use the MCP1631HV Multi-Chemistry Battery Charger Reference Design. The manual layout is as follows:

- **Chapter 1. “Product Overview”** – Important information about the MCP1631HV Multi-Chemistry Battery Charger Reference Design.
- **Chapter 2. “Installation and Operation”** – Includes instructions on how to get started with this user’s guide and a description of the user’s guide.
- **Appendix A. “Schematic and Layout”** – Shows the schematic and layout diagrams for the MCP1631HV Multi-Chemistry Battery Charger Reference Design.
- **Appendix B. “Bill Of Materials (BOM)”** – Lists the parts used to build the MCP1631HV Multi-Chemistry Battery Charger Reference Design.
- **Appendix C. “Software”** – Provides information about the application firmware and where the source code can be found.
- **Appendix D. “Design Example”** – Shows a design example.

MCP1631HV Multi-Chemistry Battery Charger Reference Design

CONVENTIONS USED IN THIS GUIDE

This manual uses the following documentation conventions:

DOCUMENTATION CONVENTIONS

Description	Represents	Examples
Arial font:		
Italic characters	Referenced books	<i>MPLAB[®] IDE User's Guide</i>
	Emphasized text	...is the <i>only</i> compiler...
Initial caps	A window	the Output window
	A dialog	the Settings dialog
	A menu selection	select Enable Programmer
Quotes	A field name in a window or dialog	"Save project before build"
Underlined, italic text with right angle bracket	A menu path	<u><i>File>Save</i></u>
Bold characters	A dialog button	Click OK
	A tab	Click the Power tab
'bnnnn	A binary number where <i>n</i> is a digit	'b00100, 'b10
Text in angle brackets < >	A key on the keyboard	Press <Enter>, <F1>
Courier font:		
Plain Courier	Sample source code	#define START
	Filenames	autoexec.bat
	File paths	c:\mcc18\h
	Keywords	_asm, _endasm, static
	Command-line options	-Opa+, -Opa-
	Bit values	0, 1
Italic Courier	A variable argument	<i>file.o</i> , where <i>file</i> can be any valid filename
0xn timer	A hexadecimal number where <i>n</i> is a hexadecimal digit	0xFFFF, 0x007A
Square brackets []	Optional arguments	mcc18 [options] <i>file</i> [options]
Curly brackets and pipe character: { }	Choice of mutually exclusive arguments; an OR selection	errorlevel {0 1}
Ellipses...	Replaces repeated text	var_name [, var_name...]
	Represents code supplied by user	void main (void) { ... }

RECOMMENDED READING

This user's guide describes how to use MCP1631HV Multi-Chemistry Battery Charger Reference Design. The following Microchip documents are available on our web site (www.microchip.com) and recommended as supplemental reference resources.

MCP1631 Data Sheet, "High-Speed, Microcontroller-Adaptable, Pulse Width Modulator", DS22063A

This data sheet provides detailed information regarding the MCP1631/MCP1631V, MCP1631HV and MCP1631VHV product family.

PIC16F883 Data Sheet, "8-Pin Flash-Based, 8-Bit CMOS Microcontrollers with Nano Watt Technology", DS41291D

This data sheet provides detailed information regarding the PIC16F883 product family.

AN1137 Application Note, "Using the MCP1631 Family to Develop Low-Cost Battery Chargers", DS01137A

THE MICROCHIP WEB SITE

Microchip provides online support via our web site at www.microchip.com. This web site is used as a means to make files and information easily available to customers. Accessible by using your favorite Internet browser, the web site contains the following information:

- **Product Support** – Data sheets and errata, application notes and sample programs, design resources, user's guides and hardware support documents, latest software releases and archived software
- **General Technical Support** – Frequently Asked Questions (FAQs), technical support requests, online discussion groups, Microchip consultant program member listing
- **Business of Microchip** – Product selector and ordering guides, latest Microchip press releases, listing of seminars and events, listings of Microchip sales offices, distributors and factory representatives

CUSTOMER SUPPORT

Users of Microchip products can receive assistance through several channels:

- Distributor or Representative
- Local Sales Office
- Field Application Engineer (FAE)
- Technical Support
- Development Systems Information Line

Customers should contact their distributor, representative or field application engineer (FAE) for support. Local sales offices are also available to help customers. A listing of sales offices and locations is included in the back of this document.

Technical support is available through the web site at: <http://support.microchip.com>

DOCUMENT REVISION HISTORY

Revision A (January 2009)

- Initial Release of this Document.

MCP1631HV Multi-Chemistry Battery Charger Reference Design

NOTES:

Chapter 1. Product Overview

1.1 INTRODUCTION

The MCP1631HV Multi-Chemistry reference design board is used to charge one to five NiMH or NiCd batteries, charge one or two cell Li-Ion batteries, or drive one or two 1W LEDs. The board uses the MCP1631HV high speed analog PWM and PIC16F883 to generate the charge algorithm for NiMH, NiCd or Li-Ion batteries.

The MCP1631HV Multi-Chemistry Battery Charger is used to evaluate Microchip's MCP1631HV in a SEPIC power converter application. As provided, the MCP1631HV Multi-Chemistry Battery Charger is user programmable using on board push buttons. The board can charge NiMH, NiCd or Li-Ion batteries. The MCP1631HV Multi-Chemistry Battery Charger provides a constant current charge (Ni-based chemistry) and constant current / constant voltage (Li-Ion) with preconditioning, cell temperature monitoring (Ni-based) and battery pack fault monitoring. Also, the charger provides a status or fault indication. The MCP1631HV Multi-Chemistry Battery Charger automatically detects the insertion or removal of a battery pack.

This chapter covers the following topics.

- What is the MCP1631HV Multi-Chemistry Battery Charger Reference Design?
- What the MCP1631HV Multi-Chemistry Battery Charger Reference Design Kit includes.

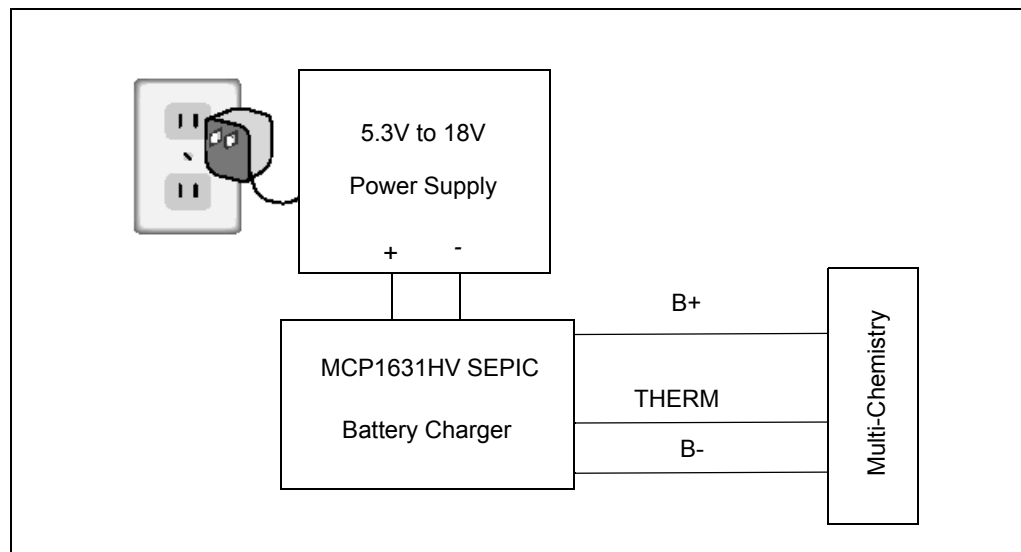

FIGURE 1-1: MCP1631HV Multi-Chemistry Battery Charger Reference Design Block Diagram.

1.2 WHAT IS THE MCP1631HV MULTI-CHEMISTRY BATTERY CHARGER REFERENCE DESIGN?

The MCP1631HV Multi-Chemistry Battery Charger is a complete stand-alone battery charger for NiMH, NiCd or Li-Ion battery packs. The board may also be used to drive LED devices using constant current mode. When charging NiMH or NiCd batteries the reference design is capable of charging one to five batteries connected in series. If Li-Ion chemistry is selected, the board is capable of charging one or two series batteries. When the LED driver is selected, the board is capable of driving one to two 1W LEDs. This board utilizes Microchip's MCP1631HV (high-speed PWM and PIC16F883 MCU). The input voltage range for the demo board is 5.3V to 16V.

The board is capable of both boosting and bucking the input voltage in order to obtain the desired output voltage because a SEPIC converter topology is used. The overvoltage limit for the board is set to 9V. The powertrain components may be changed to allow for higher output voltages and power.

TABLE 1-1: MULTI-CHEMISTRY CHARGER CAPABILITY

Battery Chemistry	1 Cell	2 Cell	3 Cell	4 Cell	5 Cell
Li-Ion	2A	1A	NA	NA	NA
NiMH or NiCd	1.5A	1.5A	1.5A	1.5A	1.5A
LED Driver	300 mA	300 mA	NA	NA	NA

An input terminal block is provided to apply the input voltage to the charger. An output header is also provided as a means to connect the external battery pack or simulated battery load and external 10K thermistor. A programming header is available for updating the firmware contained in the PIC16F883.

1.3 WHAT THE MCP1631HV MULTI-CHEMISTRY BATTERY CHARGER REFERENCE DESIGN KIT INCLUDES

This MCP1631HV Multi-Chemistry Battery Charger Reference Design kit includes:

- The MCP1631HV Multi-Chemistry Battery Charger Board, 102-00232
- Analog and Interface Products Demonstration Boards CD-ROM includes (DS21912):
 - MCP1631HV Multi-Chemistry Battery Charger User's Guide, (DS51697).
 - MCP1631 Data Sheet, "High-Speed, Microcontroller-Adaptable, Pulse Width Modulator", (DS22063).
 - PIC16F883 Data Sheet, "8-Pin Flash-Based, 8-Bit CMOS Microcontrollers with nanoWatt Technology", (DS41291).
 - Application Note AN1137, "Using the MCP1631 Family to Develop Low-Cost Battery Chargers", (DS01137).

Chapter 2. Installation and Operation

2.1 INTRODUCTION

The MCP1631HV Multi-Chemistry Battery Charger demonstrates Microchip's high-speed Pulse Width Modulator (PWM), MCP1631HV, used in a multi-chemistry battery charger application. When used in conjunction with a microcontroller, the MCP1631HV will control the power system duty cycle to provide output voltage or current regulation. The PIC16F883 microcontroller can be used to regulate output voltage or set current, switching frequency and maximum duty cycle. The MCP1631HV generates the duty cycle and provides fast overcurrent protection based upon various external inputs. External signals include the switching frequency oscillator, the reference voltage, the feedback voltage and the current sense. The output signal is a square-wave pulse. The power train used for the MCP1631HV Multi-Chemistry Battery Charger is a Single-Ended Primary Inductive Converter (SEPIC). The MCP1631HV microcontroller is programmable, allowing the user to modify or develop their own firmware routines to further evaluate the MCP1631HV Multi-Chemistry Battery Charger in this application.

2.2 FEATURES

The MCP1631HV Multi-Chemistry Battery Charger has the following features:

- Input Operating Voltage Range - +5.3V to +16V
- Maximum of 2A Charge Current for single cell Li-Ion
- Charge NiMH, NiCd or Li-Ion Chemistries
- Charge 1 cell or 2 cell Li-Ion Batteries in Series
- Charge 1 cell to 5 cell NiMH or NiCd Batteries in Series
- Drive one or two 1 Watt LEDs in series.
- Select Chemistry and Cells using push-buttons
- ON/OFF switch
- Charge Status Indication
- Programmable Charge Profile
- Programmable Overvoltage Shutdown (1.8V/Cell for NiMH/NiCd or 4.4V/Cell for Li-Ion)
- Complete "C" source code is provided

2.3 GETTING STARTED

The MCP1631HV Multi-Chemistry Battery Charger is fully assembled and tested for charging one or two series Li-Ion Batteries, one to five series cell NiMH or NiCd batteries, or driving one to two 1 Watt LEDs. The charge termination for Li-Ion is based upon a percentage of fast charge current, the charge termination for NiMH is based on a negative voltage change versus time or positive temperature change versus time. This board requires the use of an external voltage source to charge the series connected batteries with a range of +5.3V to +16V input. An external load and thermistor is also required to evaluate the charger reference design.

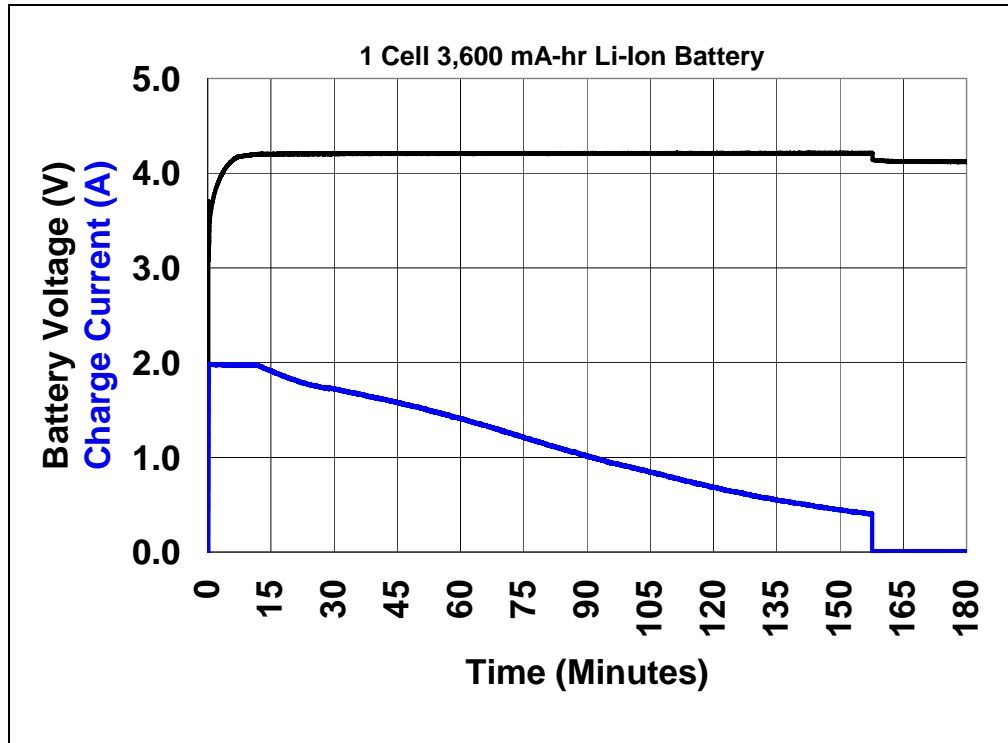

FIGURE 2-1: MCP1631HV Multi-Chemistry Battery Charger Charge Profile, Li-Ion.

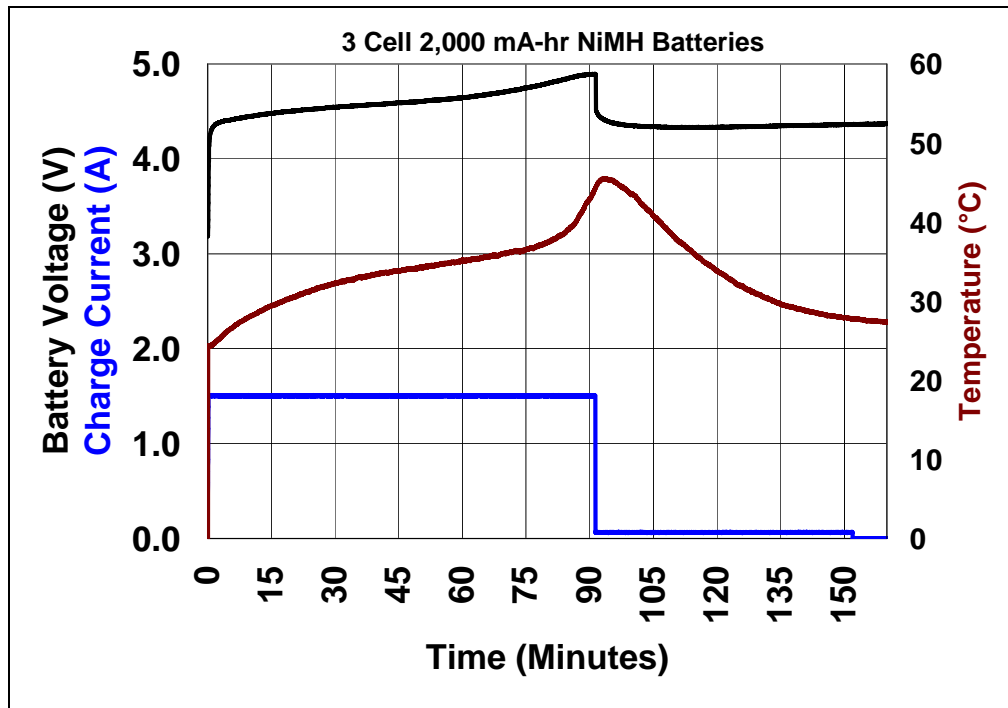

FIGURE 2-2: MCP1631HV Multi-Chemistry Battery Charger Charge Profile, NiMH/NiCd.

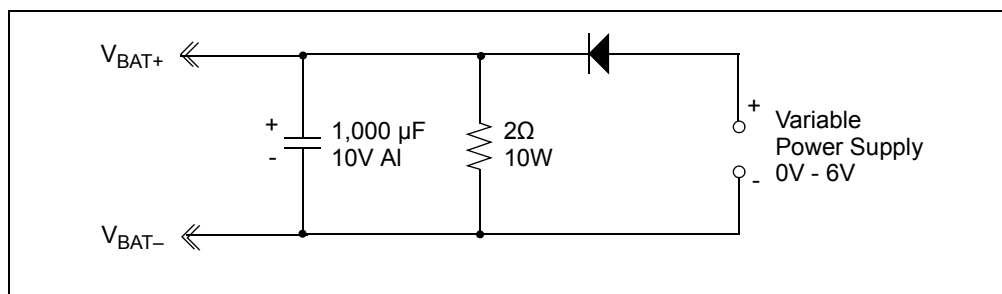

FIGURE 2-4: Simulated Battery Load.

2.3.1.3 SELECTING BATTERY CHEMISTRY AND NUMBER OF CELLS

- Three push buttons are used to start a charge cycle, select chemistry and select number of series cells. There are two LEDs, (red - NiMH, green - Li-Ion, red + green - LED Driver) used to indicate chemistry type and four yellow LEDs to indicate the number of series cells selected (D6, D7, D8, D9).
- S1 (ON/OFF) is used to start and stop the charge cycle or to enter the programming mode. When the input voltage is within the specified operating range (+5.3V to +16V), press and hold the ON/OFF button for 5 seconds, all LEDs with the exception of D3 should be illuminated. Release S1 and STATUS LED (D3) will be flashing, indicating that the board is in programming mode.
- Press S2 (CHEM) to select the desired chemistry, indication is provided by red LED D4 (Li-Ion) or green LED D5 (NiMH/NiCd) or both (LED Driver).
- Press S3 (CELLS) to select the number of series cells, indication is provided by yellow LEDs D6 thru D9 where D6 = bit 0 and D9 = bit 3 of a 4-bit hexadecimal value.
- Once the desired chemistry and number of cells is selected, press S1 (ON/OFF) to store the settings. The selected chemistry LED and number of series cells LED both should be illuminated.
- To start a charge cycle press and release S1. D3 (green) will be illuminated indicating a charge cycle has begun, the selected chemistry LED should flash slowly indicating normal charge cycle conditions.
- If the chemistry LED is not flashing and the Status LED is flashing, a fault condition has persisted for 5 attempts indicating that the charge cycle has terminated.
- Remove input voltage and check connections and verify the proper battery pack chemistry and number of series cells.
- Once the problem is corrected, apply the input voltage, verify chemistry and # of cells LEDs and press S1 to start a charge cycle.

Note: For single cell Li-Ion, a 3600 mA-Hr battery with internal protection circuitry is recommended for evaluation. For NiMH charge cycle, Panasonic HHR-210AA/B2B were used to develop the -dV/dt and +dT/dt termination methods.

Installation and Operation

2.3.1.4 STATUS LED

The MCP1631HV Multi-Chemistry Battery Charger has an LED to indicate charge status or fault status. Table 2-1 represents the state of the Status, Chemistry, and Display LEDs during various states of the charge cycle.

TABLE 2-1: LED INDICATOR TABLE

Mode	Status	Li-Ion	NiMH	LSBit 0	Bit 1	Bit 2	MSBit 3
Power-Up	OFF	CHEM	CHEM	#CELLS	#CELLS	#CELLS	#CELLS
Enter Config	OFF	ON	ON	ON	ON	ON	ON
Config	4Hz	CHEM	CHEM	#CELLS	#CELLS	#CELLS	#CELLS
Calibrated	4Hz	OFF	OFF	ON	ON	ON	ON
Off	OFF	CHEM	CHEM	#CELLS	#CELLS	#CELLS	#CELLS
Charging	ON	1/2 Hz CHEM	1/2 Hz CHEM	#CELLS	#CELLS	#CELLS	#CELLS
Fault	FLASH	CHEM	CHEM	#CELLS	#CELLS	#CELLS	#CELLS
Fault-OV	2Hz	CHEM	CHEM	#CELLS	#CELLS	#CELLS	#CELLS
Fault-OT	1Hz	CHEM	CHEM	#CELLS	#CELLS	#CELLS	#CELLS
Term. Code (#CELLS pressed)	No Change	No Change	No Change	$\Delta V/\Delta t$	$\Delta T/\Delta t$	OVP	OTP
State Code (CHEM pressed)	No Change	No Change	No Change	STATE LS Bit 0	STATE Bit 1	STATE Bit 2	STATE MS Bit 3

TABLE 2-2: WHEN 'CHEM' SWITCH IS PRESSED, SHOWS CURRENT STATE

State Code	LSBit 0	Bit 1	Bit 2	MSBit 3
Startup	1	0	0	0
ON	0	1	0	0
Qualification	1	1	0	0
NiMH CC	0	0	1	0
NiMH Topoff	1	0	1	0
Li-Ion CC	0	1	1	0
Li-Ion CV	1	1	1	0
LED CC	0	0	0	1
Overvoltage	1	0	0	1
Off	0	1	0	1

2.3.1.5 CHARGE PROFILE

- Li-Ion
 - Qualification: Precharge at 200 mA for $V_{CELL} < 3.0V$
 - Constant Current = 2A for 1 Cell, 1A for 2 Cell
 - Constant Voltage = 4.20V, User Calibrated
 - Charge Termination = 140 mA for 1 Cell and 2 Cell
 - Overvoltage Detection, once detected, attempt to restart charge cycle 5 times, if overvoltage is persistent, terminate attempts and flash STATUS LED.
- NiMH/NiCd
 - Qualification: Precharge at 200 mA for $V_{CELL} < 0.9V$.
 - Constant Current = 1.5A for 1 to 5 Cells.
 - Terminate Fast Charge for $-dV/dT$ or $+dT/dt$.
 - Timed 50 mA top off charge for 1 hour.
 - Overvoltage Detection, once detected, will attempt to restart charge cycle five times. If overvoltage is still present, charging will terminate and STATUS LED will flash.
- LED Driver
 - Constant Current = 0 to 300 mA for 1 to 2 LEDs.
 - Pressing CHEM switch increments output current. Limited to 300 mA.
 - Pressing CELLS switch decrements output current. Limited to 0 mA.
 - Overvoltage Detection, once detected, will attempt to restart charge cycle five times. If overvoltage is still present, charging will terminate and STATUS LED will flash.

2.3.1.6 PROGRAMMING

Header J3 is provided for in-system circuit programming using either ICD 2 or PICKit™ 2.

2.3.1.7 DATA LOGGING

Header J5 is provided for serial data logging using the PICKit™ Serial Analyzer. The source code for the evaluation board contains the code necessary to transmit data via a PICKit™ Serial interface to a PC running the PICKit Serial Analyzer GUI interface. The data currently logged consists of charging current setpoint, output voltage, temperature thermistor voltage, current system state, and termination code.

The data logging feature allows the user to create and save a complete charging profile for a specific battery pack. The interface software provided with the PICKit Serial Analyzer allows the user to save the logged data to a file.



MCP1631HV MULTI-CHEMISTRY BATTERY CHARGER REFERENCE DESIGN

Appendix A. Schematic and Layout

A.1 INTRODUCTION

This appendix contains the following schematics and layouts for the MCP1631 Multi-Chemistry Battery Charger Reference Design:

- Board – Schematic
- Board – Top Silk Layer
- Board – Bottom Silk Layer
- Board – Top Metal Layer
- Board – Mid1 Metal Layer
- Board – Mid2 Metal Layer
- Board – Bottom Metal Layer

MCP1631HV Multi-Chemistry Battery Charger Reference Design

A.2 BOARD – SCHEMATIC

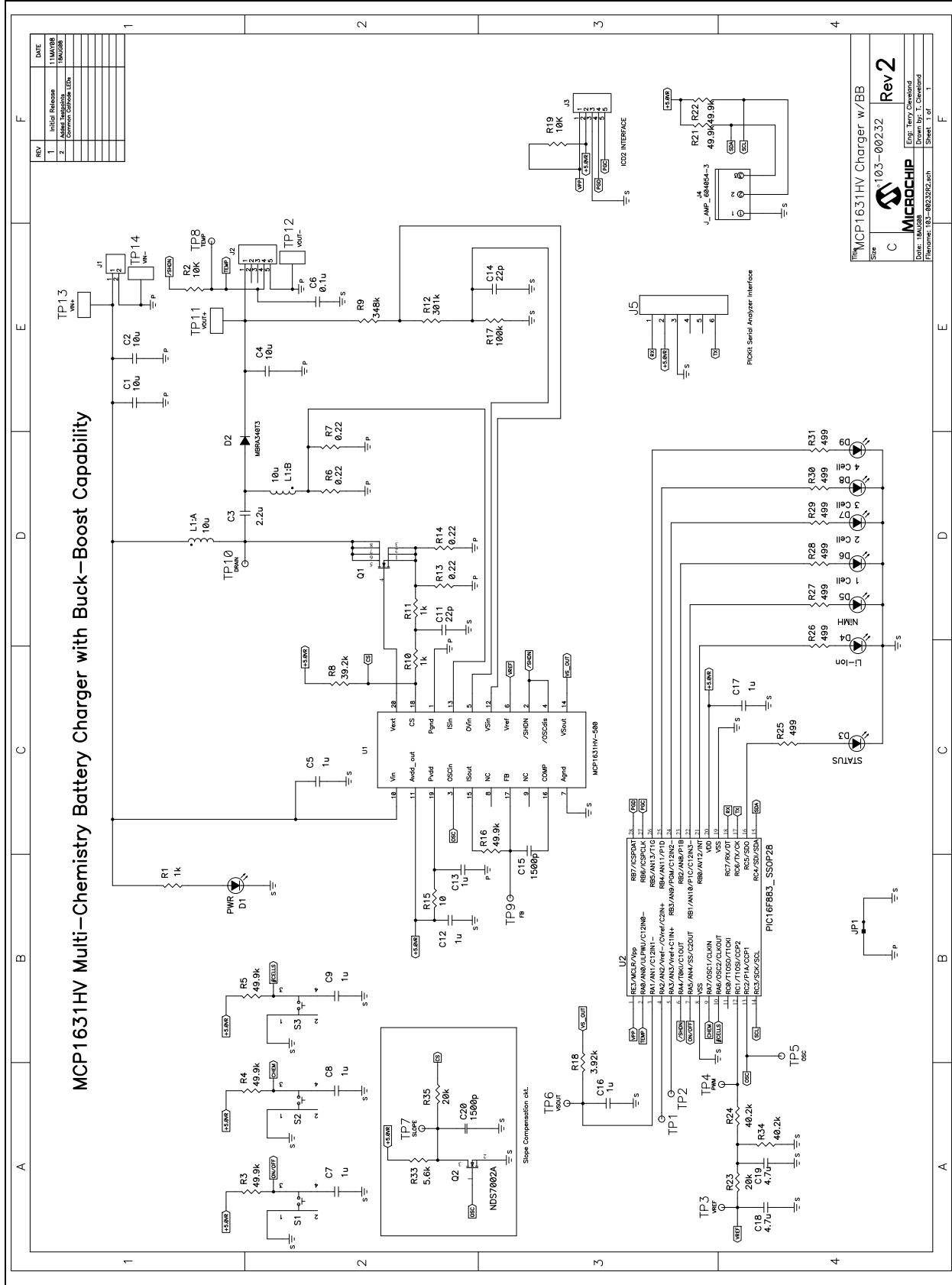

A.3 BOARD – TOP SILK LAYER

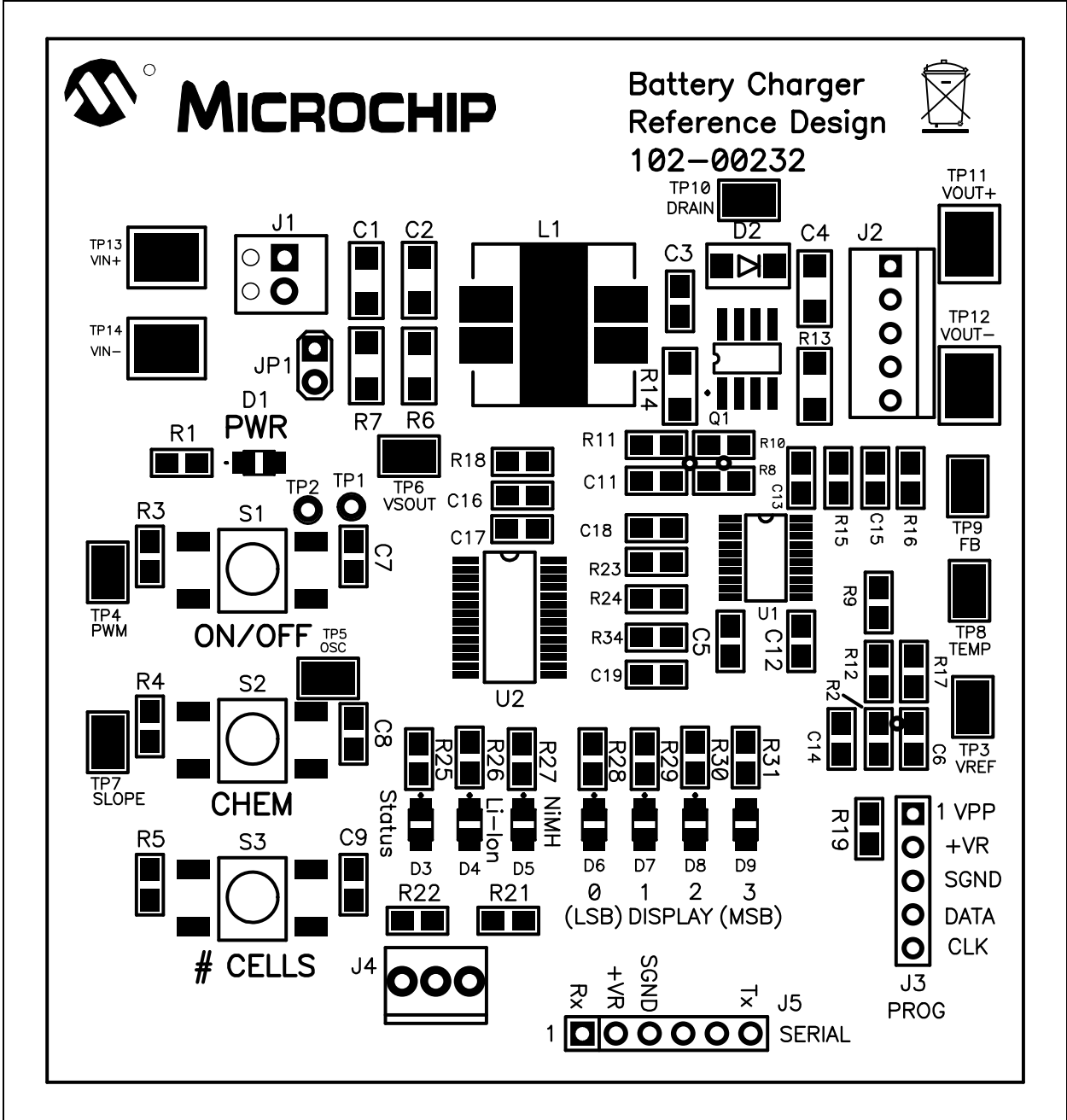

A.4 BOARD – BOTTOM SILK LAYER

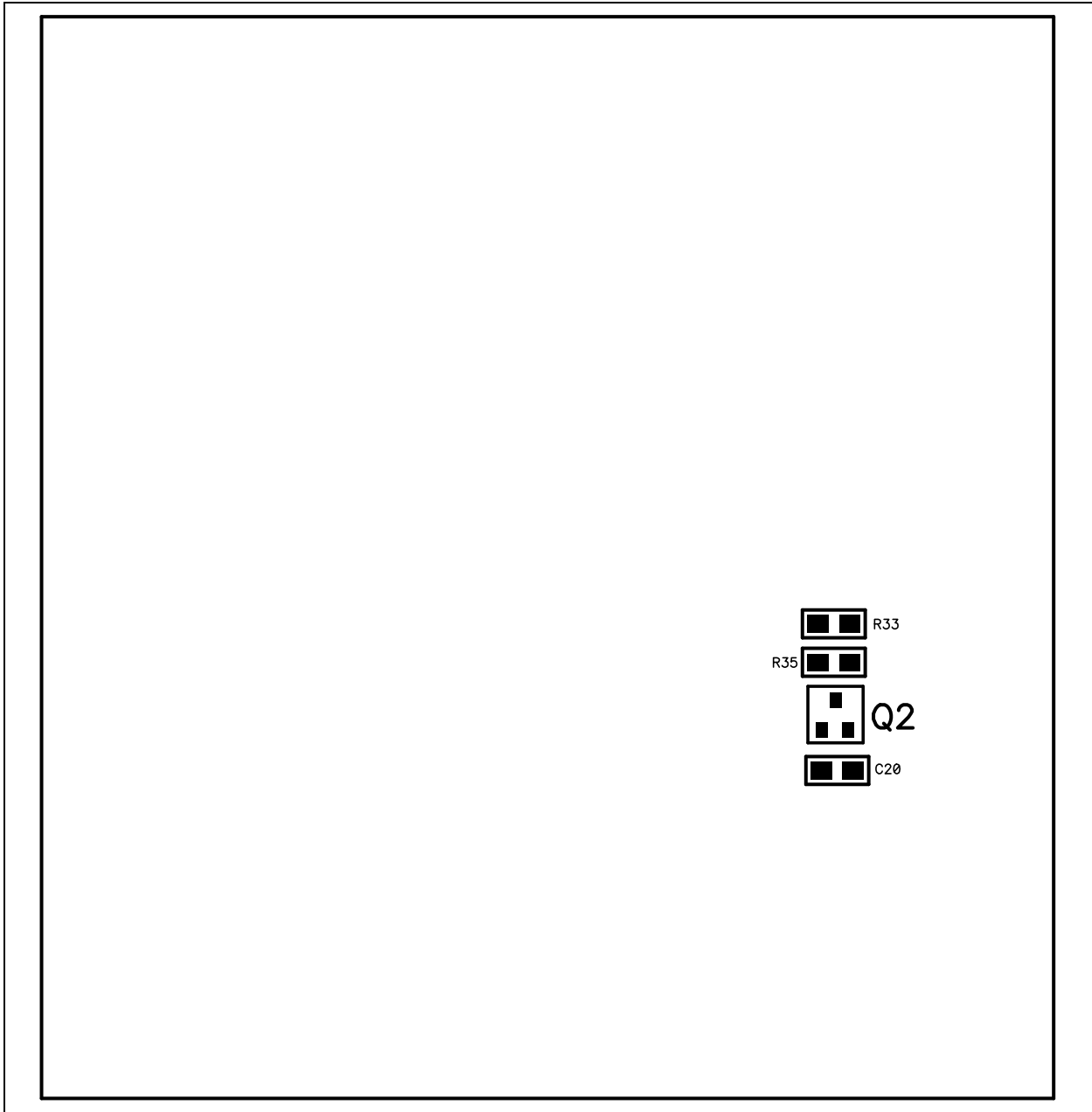

A.5 BOARD – TOP METAL LAYER

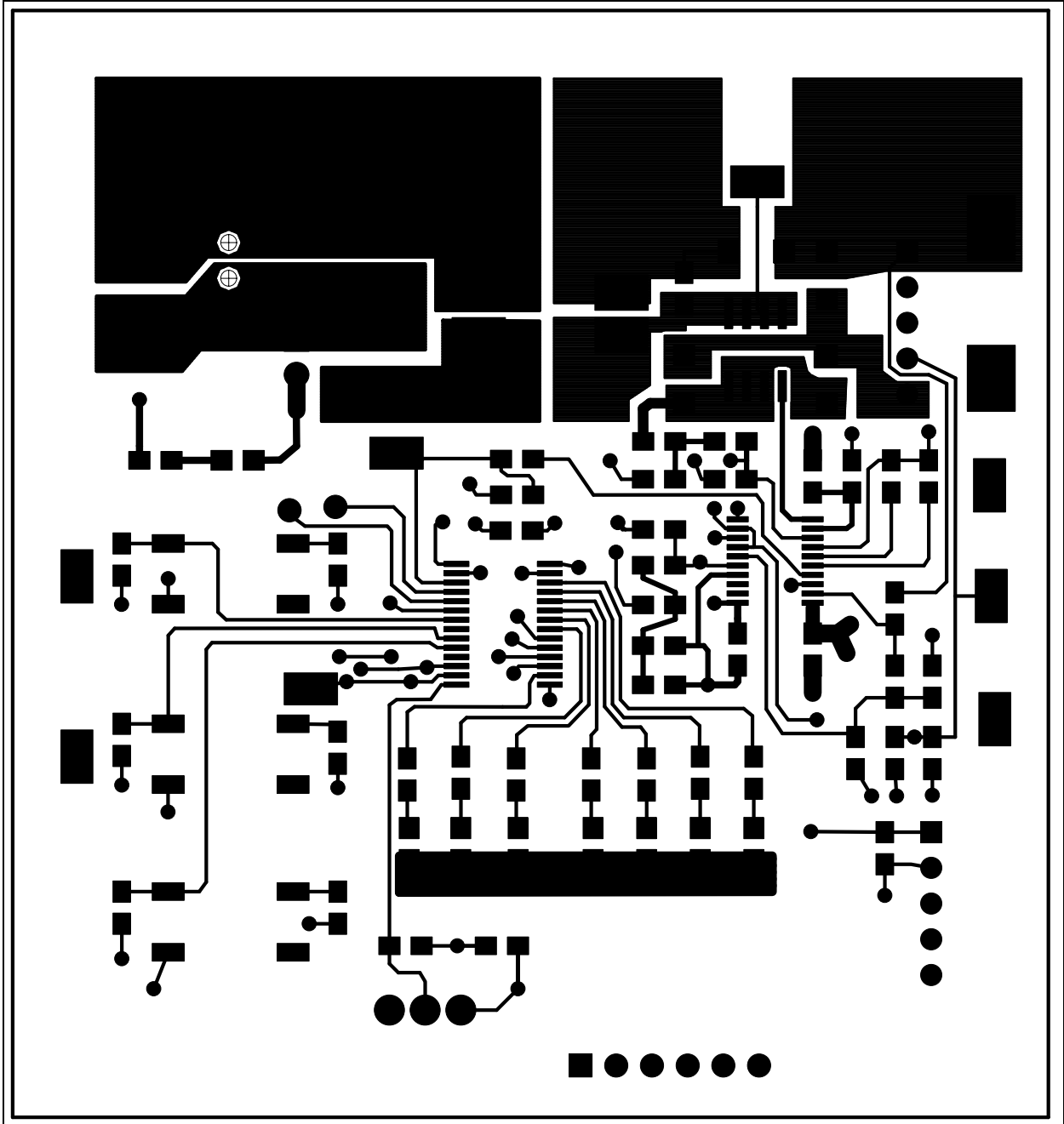

A.6 BOARD – MID1 METAL LAYER

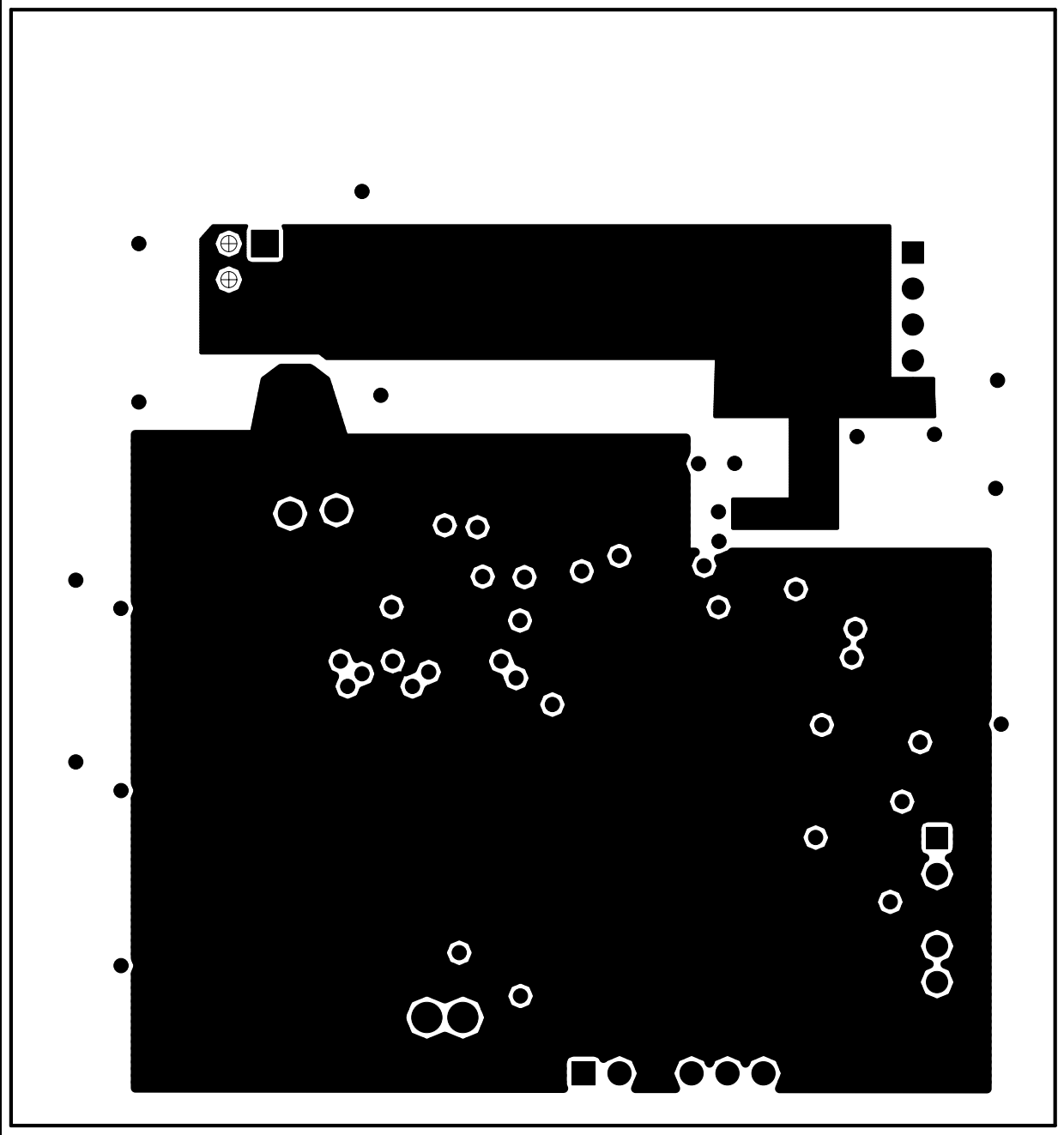

A.7 BOARD – MID2 METAL LAYER

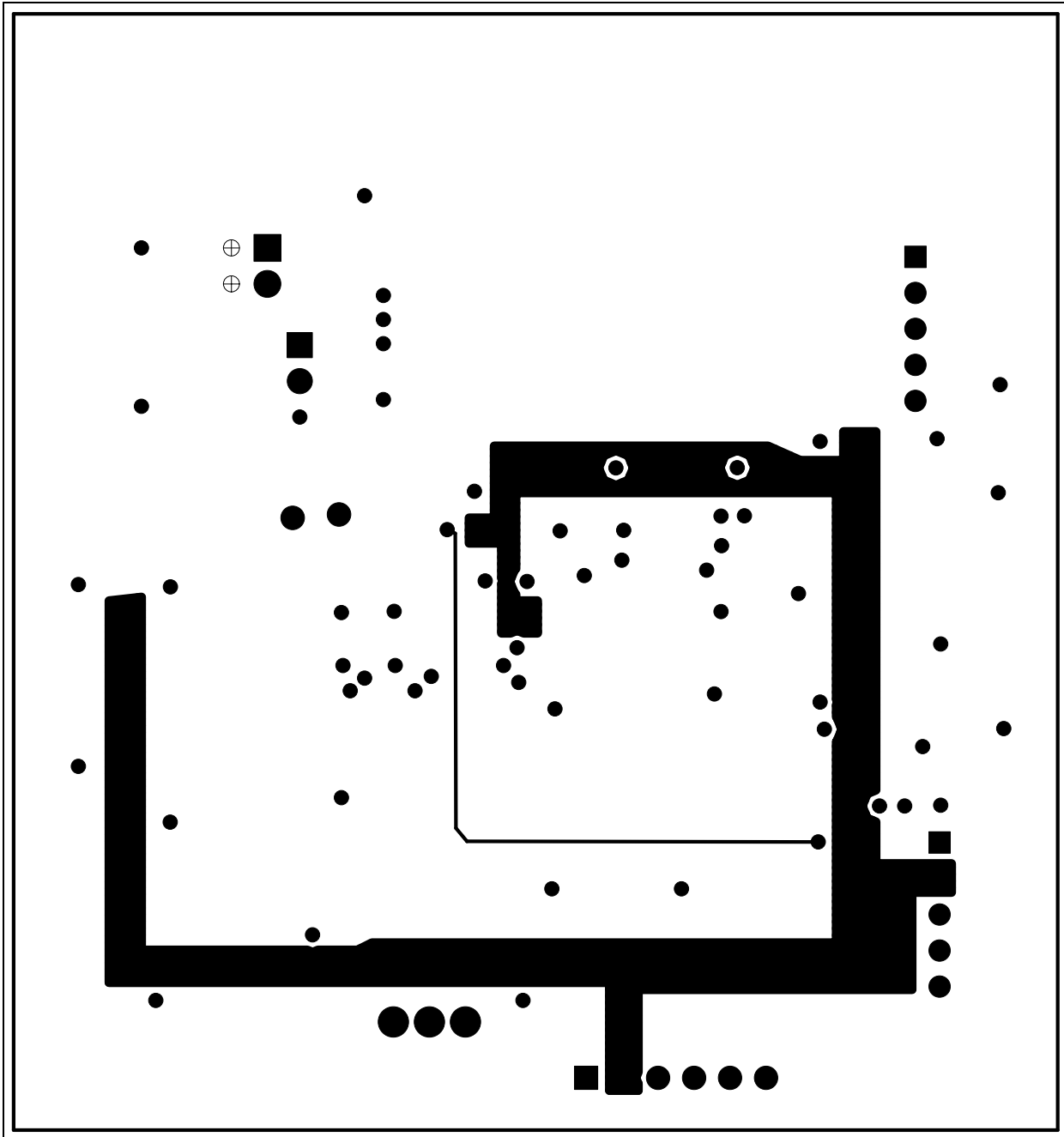

A.8 BOARD – BOTTOM METAL LAYER

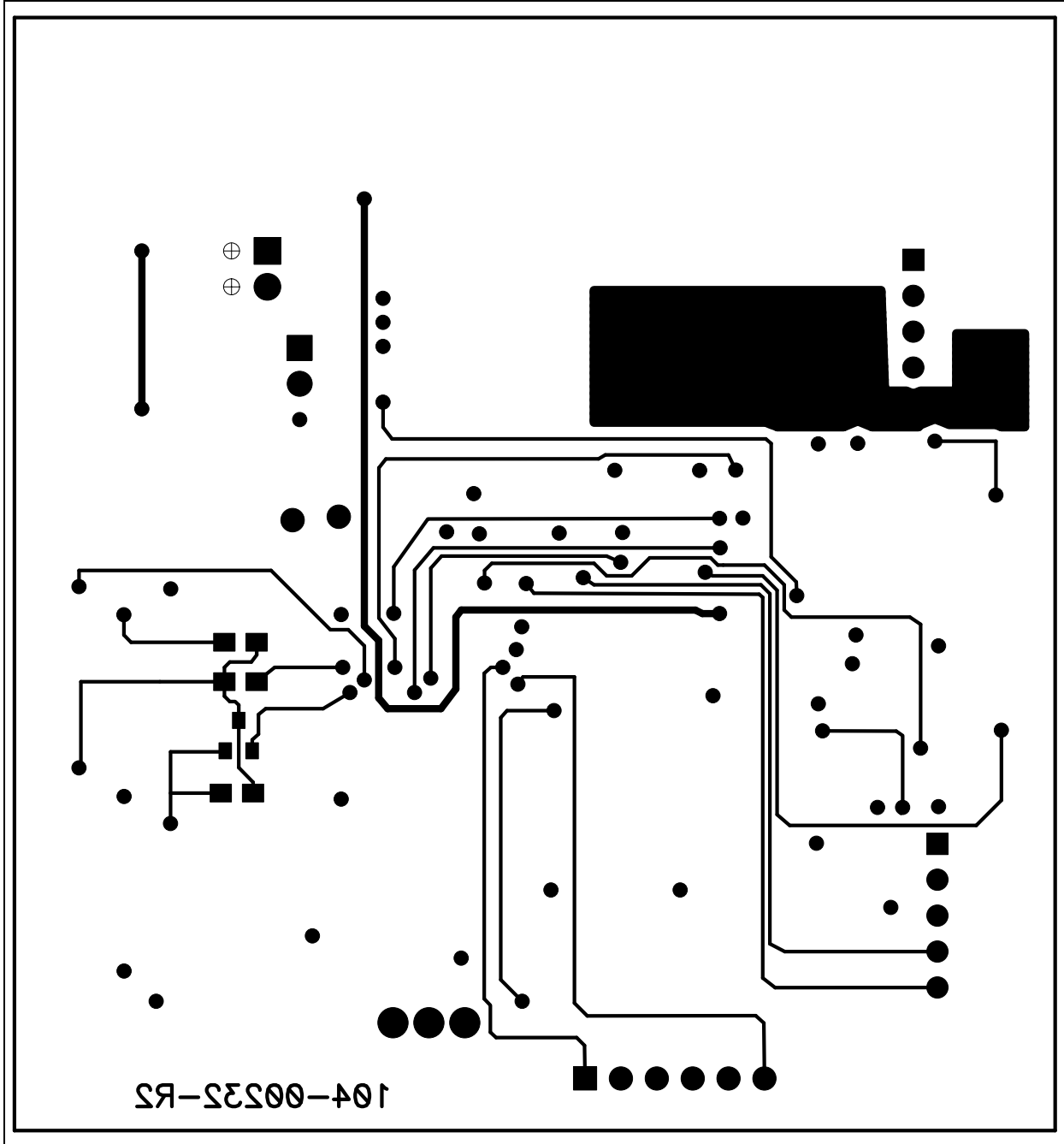



MCP1631HV MULTI-CHEMISTRY BATTERY CHARGER REFERENCE DESIGN

Appendix B. Bill Of Materials (BOM)

TABLE B-1: BILL OF MATERIALS (BOM)

Qty	Reference	Description	Manufacturer	Part Number
4	B1, B2, B3, B4	BUMPON HEMISPHERE .44X.20 CLEAR	3M	SJ-5303 (CLEAR)
3	C1, C2, C4	CAP CERAMIC 10UF 25V X5R 1206	Panasonic® - ECG	ECJ-3YB1E106M
2	C11, C14	CAP 22PF 50V CERM CHIP 0805 SMD	Panasonic - ECG	ECJ-2VC1H220J
2	C15, C20	CAP 1500PF 50V CERM CHIP 0805	Panasonic - ECG	ECJ-2VB1H152K
2	C18, C19	CAP CER 4.7UF 10V X7R 20% 0805	TDK Corporation	C2012X7R1A475M
1	C3	CAP CER 2.2UF 25V X7R 0805	Murata Electronics® North America	GRM21BR71E225KA73 L
8	C5, C7, C8, C9, C12, C13, C16, C17	CAP CER 1.0UF 25V X7R 0805	Taiyo Yuden	TMK212BJ105KG-TR
1	C6	CAP .1UF 16V CERAMIC X7R 0805	Panasonic - ECG	ECJ-2VB1C104K
2	D1, D4	LED 0805 Super RED Clear	Para Light Corp.	L-C170KRCT-U1
1	D2	DIODE SCHOTTKY 30V 3A SMA	Diodes Inc.	B330A-13-F
2	D3, D5	LED 0805 Super Green Clear	Para Light Corp.	L-C170KGCT-U1
4	D6, D7, D8, D9	LED 0805 Super Yellow Clear	Para Light Corp.	L-C170KYCT-U1
1	J1	CONN TERM BLOCK 2.54MM 2POS	Phoenix Contact	1725656
1	J2	CONN HEADER 5POS .100 VERT TIN FRICTION LOCK	Molex® Electronics	22-23-2051
1	J3	CONN HEADER 5POS .100 VERT TIN	Molex Electronics	22-03-2051
1	J4	CONN HEADER 3POS .100 VERT TIN	Molex Electronics	22-23-2031
1/6	J5	CONN HEADER .100 SNGL R/A 36POS	3M	929835-01-36-RK
1	JP1	BARE WIRE, 22 AWG to 26 AWG, 0.330	—	—
1	L1	INDUCT/XFRMR SHIELD DL 10UH SMD	Würth Elektronik	744870100
1	PCB	RoHS Compliant Bare PCB, MCP1631 Multi-Chemistry Charger with Buck-Boost	—	104-00232

Note 1: The components listed in this Bill of Materials are representative of the PCB assembly. The released BOM used in manufacturing uses all RoHS-compliant components.

MCP1631HV Multi-Chemistry Battery Charger Reference Design

TABLE B-1: BILL OF MATERIALS (BOM) (CONTINUED)

Qty	Reference	Description	Manufacturer	Part Number
1	Q1	HEX/MOS N-CHAN 30V 8.3A 8SOIC	International Rectifier	IRF7807VTRPBF
1	Q2	MOSFET N-CH 60V 280MA SOT-23	Fairchild Semiconductor®	NDS7002A
3	R1, R10, R11	RES 1.00K OHM 1/8W 1% 0805 SMD	Panasonic - ECG	ERJ-6ENF1001V
1	R12	RES 301K OHM 1/8W 1% 0805 SMD	Panasonic - ECG	ERJ-6ENF3013V
1	R15	RES 10.0 OHM 1/8W 1% 0805 SMD	Panasonic - ECG	ERJ-6ENF10R0V
1	R17	RES 100K OHM 1/8W 1% 0805 SMD	Panasonic - ECG	ERJ-6ENF1003V
1	R18	RES 3.92K OHM 1/8W 1% 0805 SMD	Panasonic - ECG	ERJ-6ENF3921V
2	R2, R19	RES 10.0K OHM 1/8W 1% 0805 SMD	Panasonic - ECG	ERJ-6ENF1002V
2	R23, R35	RES 20.0K OHM 1/8W 1% 0805 SMD	Panasonic - ECG	ERJ-6ENF2002V
7	R25, R26, R27 R28, R29, R30 R31	RES 499 OHM 1/8W 1% 0805 SMD	Panasonic - ECG	ERJ-6ENF4990V
6	R3, R4, R5, R16, R21, R22	RES 49.9K OHM 1/8W 1% 0805 SMD	Panasonic - ECG	ERJ-6ENF4992V
1	R33	RES 5.60K OHM 1/8W 1% 0805 SMD	Panasonic - ECG	ERJ-6ENF5601V
2	R34, R24	RES 40.2K OHM 1/8W 1% 0805 SMD	Panasonic - ECG	ERJ-6ENF4022V
4	R6, R7, R13, R14	RES .22 OHM 1/4W 1% 1206 SMD	Panasonic - ECG	ERJ-8RQFR22V
1	R8	RES 39.2K OHM 1/8W 1% 0805 SMD	Panasonic - ECG	ERJ-6ENF3922V
1	R9	RES 348K OHM 1/8W 1% 0805 SMD	Panasonic - ECG	ERJ-6ENF3483V
3	S1, S2, S3	SWITCH TACT 6MM 260GF SMT	E-Switch	TL3301NF260QG
4	TP11-TP14	SMT Testpoint	Keystone Electronics®	5016
1	U1	MCP1631HV 5.0V 20 Pin TSSOP High Speed PWM	Microchip Technology Inc.	MCP1631HV-500E/ST
1	U2	IC PIC MCU FLASH 4KX14 28SSOP	Microchip Technology Inc.	PIC16F883-I/SS

Note 1: The components listed in this Bill of Materials are representative of the PCB assembly. The released BOM used in manufacturing uses all RoHS-compliant components.

Appendix C. Software

C.1 DEVICE SOFTWARE FLOWCHART

For the latest copy of the MCP1631HV Multi-Chemistry Battery Charger Reference Design firmware, visit our web site at www.microchip.com.

C.1.1 Software Functions

C.1.1.1 INTERRUPT()

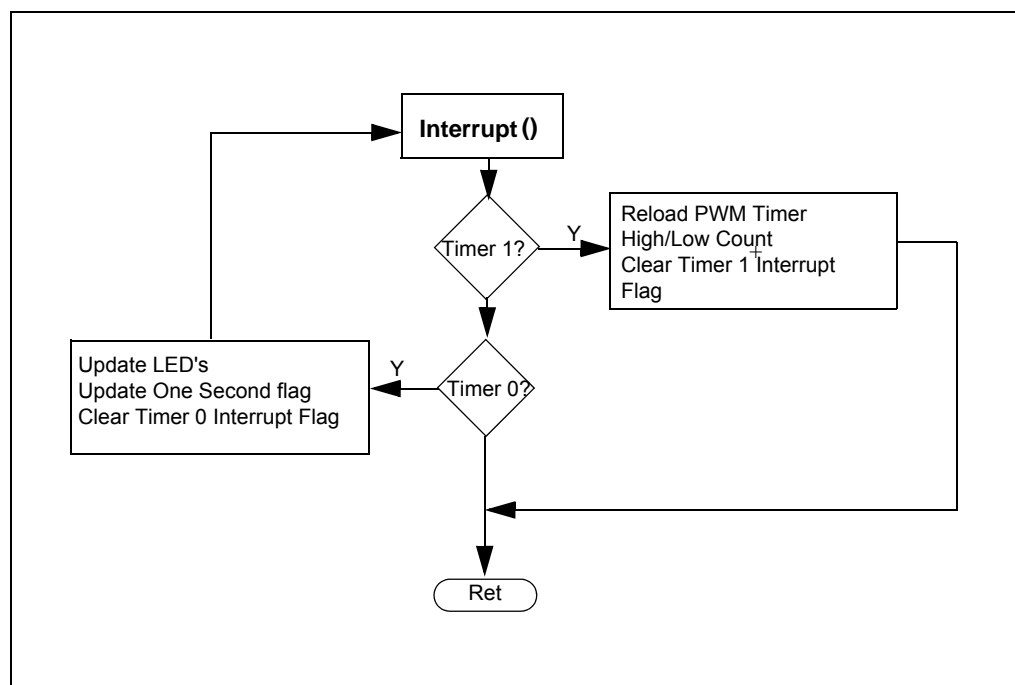

MCP1631HV Multi-Chemistry Battery Charger Reference Design

C.1.1.2 MAIN()

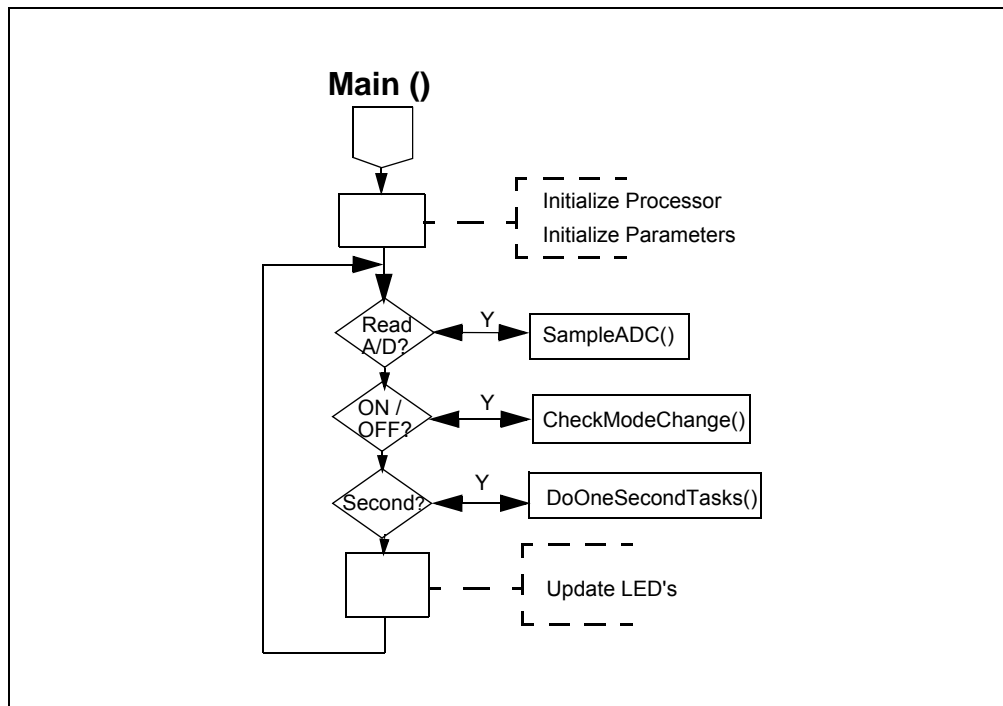

C.1.1.3 SAMPLEADC()

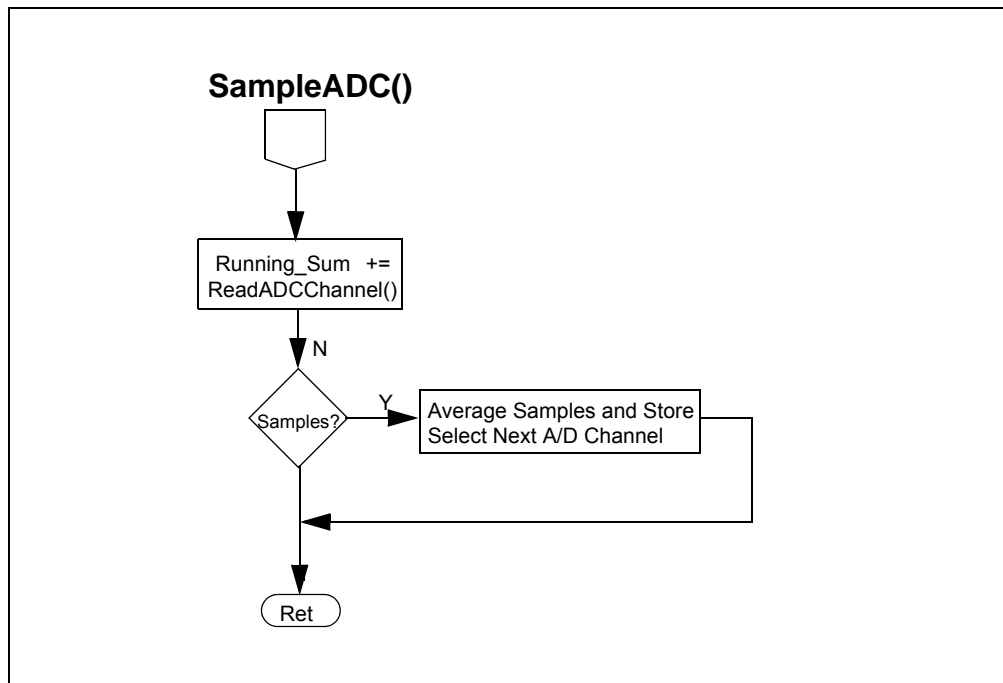

C.1.1.4 READADCCHANNEL()

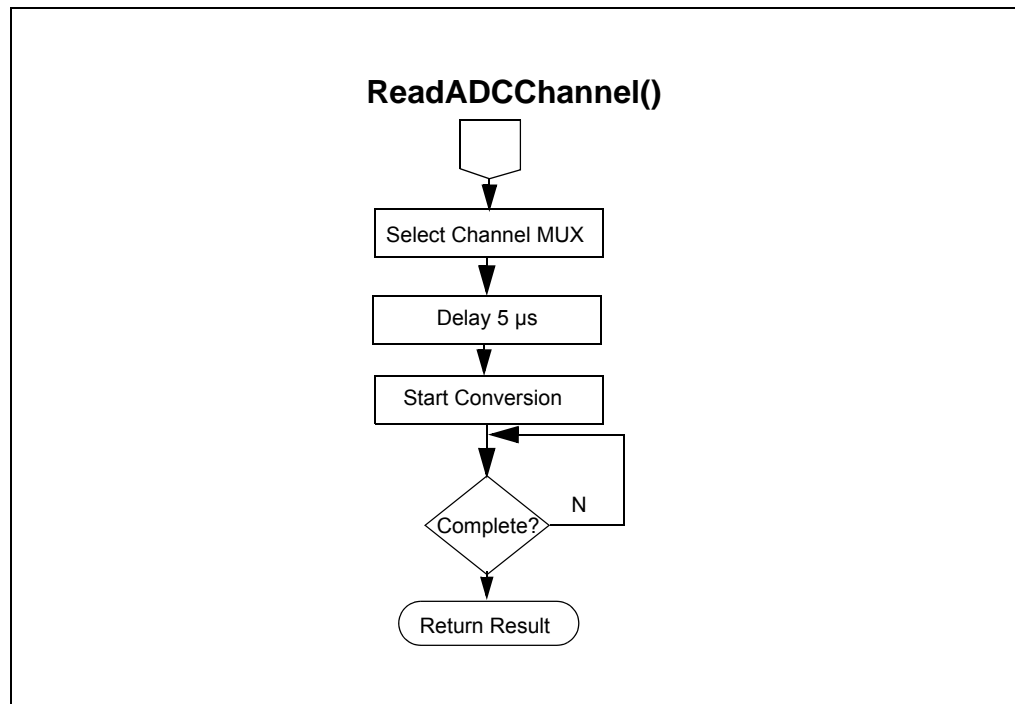

C.1.1.5 CHECKMODECHANGE()

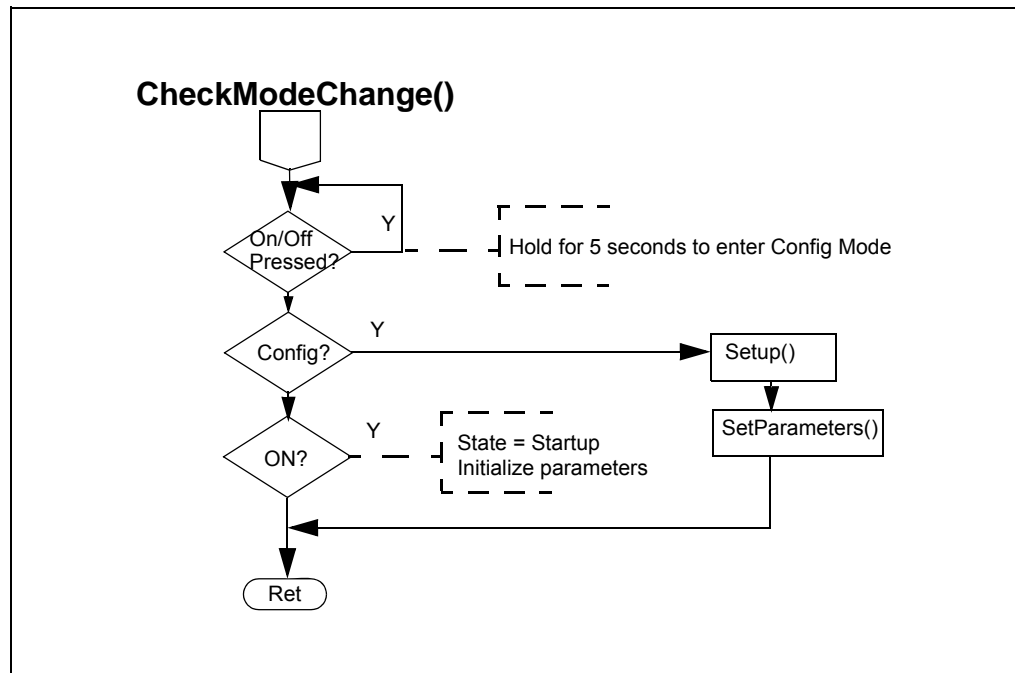

C.1.1.6 SETPARAMETERS()

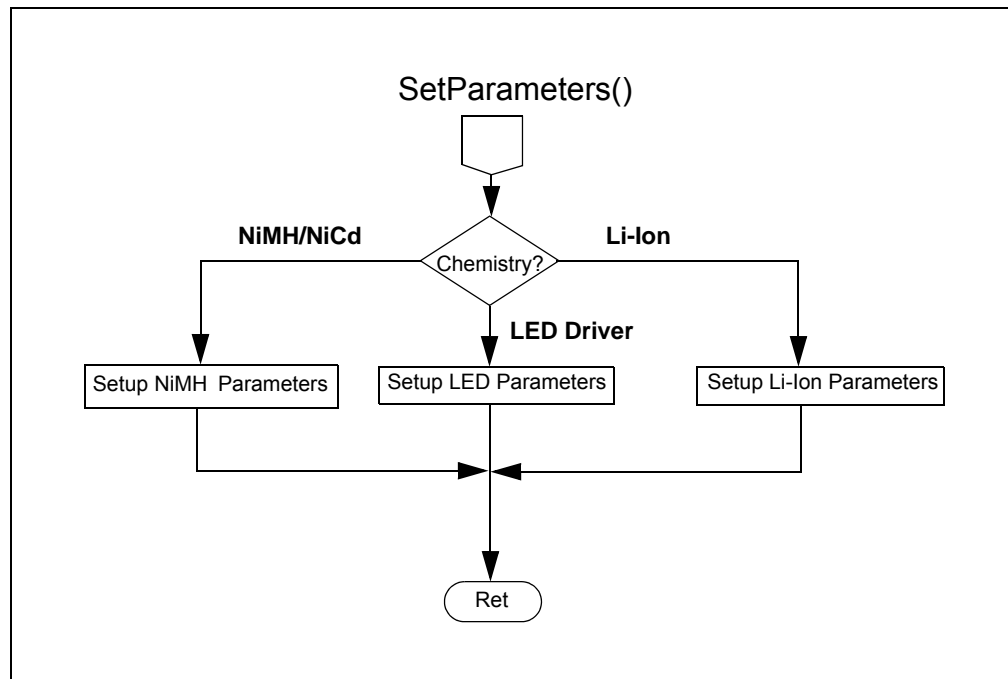

C.1.1.7 SETIREF()

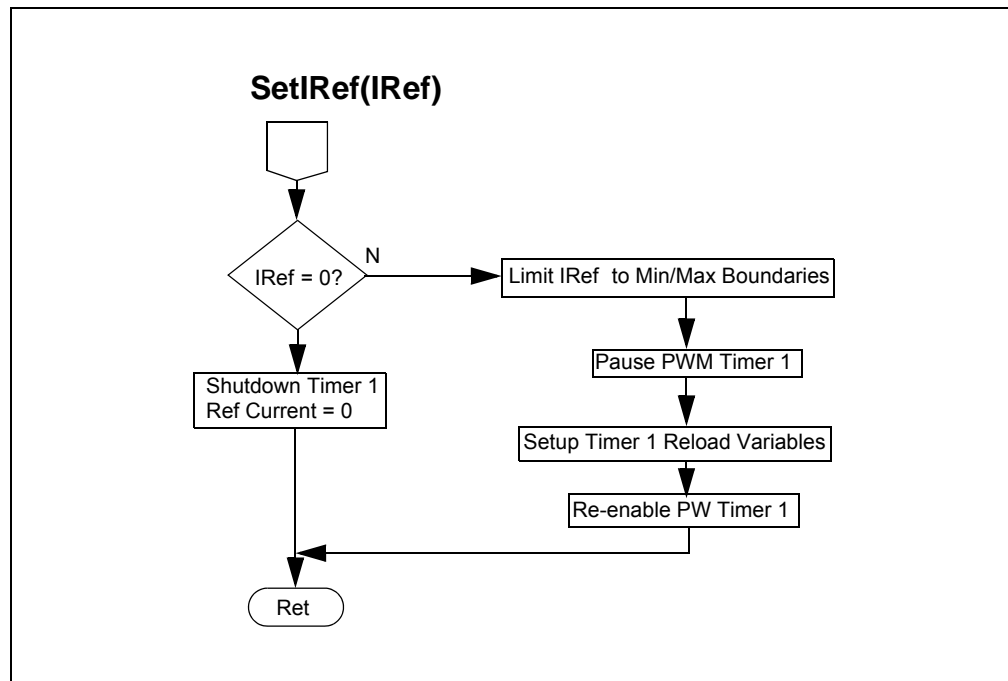

C.1.1.8 SETUP()

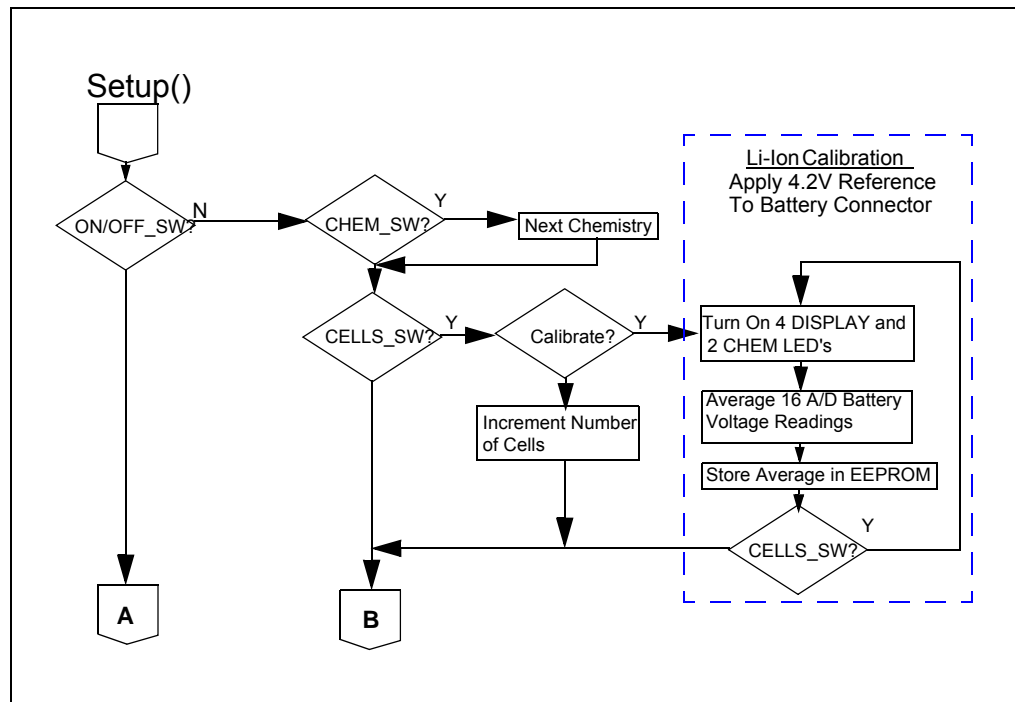

C.1.1.9 INCREMENTIREF()

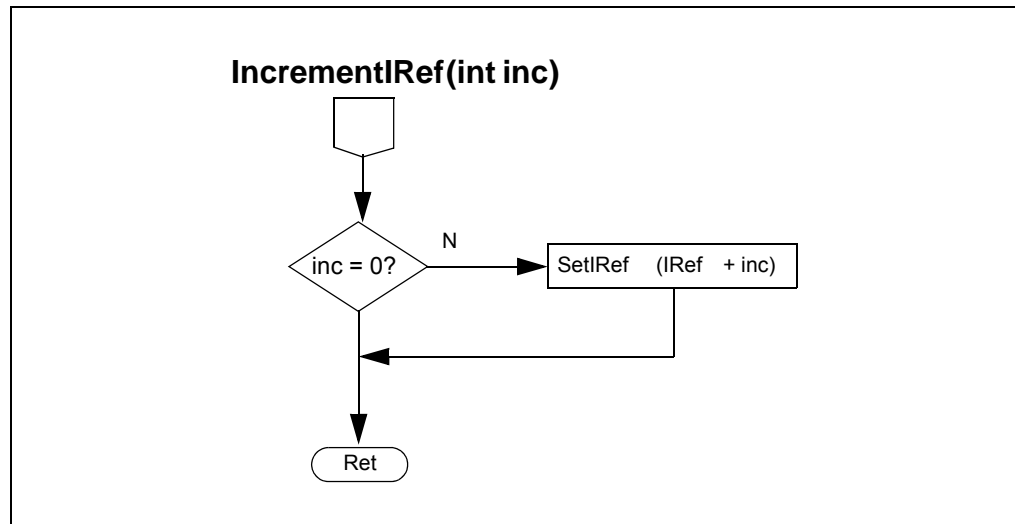

C.1.1.10 DOONESECONDTASKS()

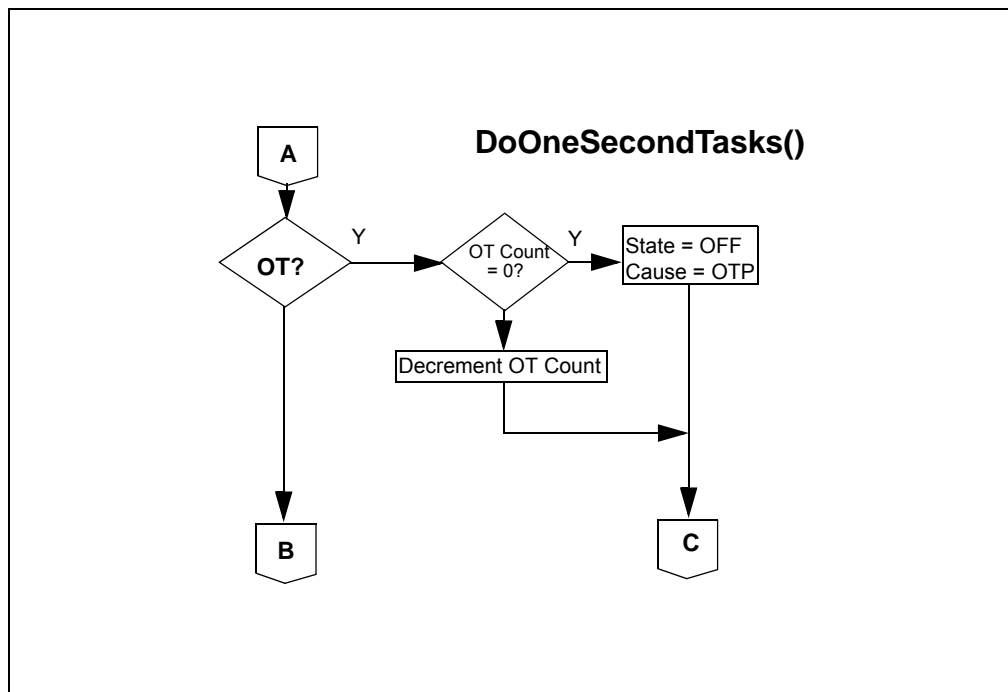
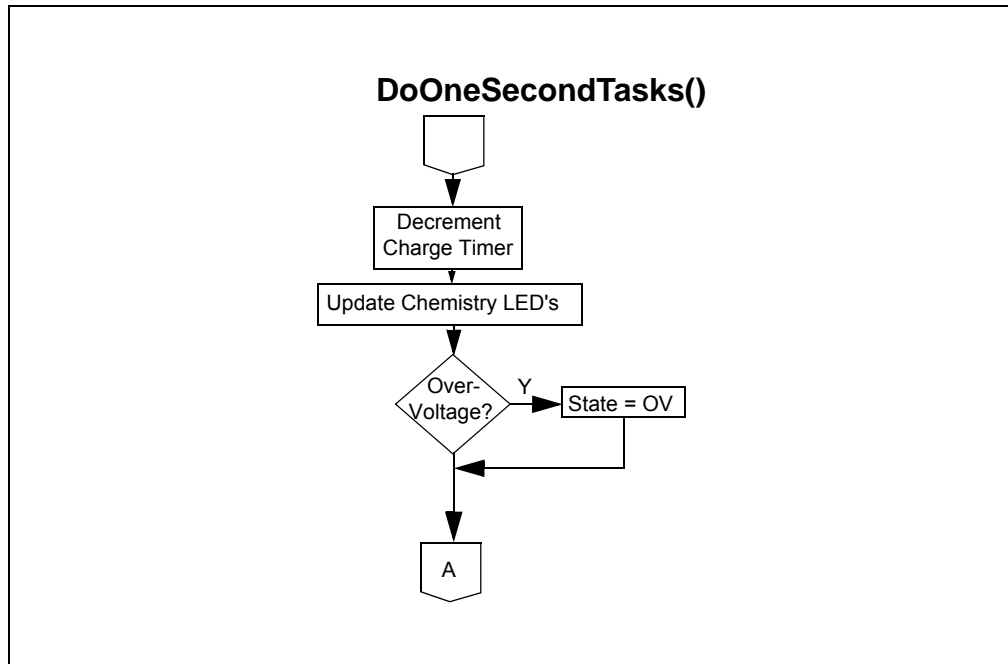

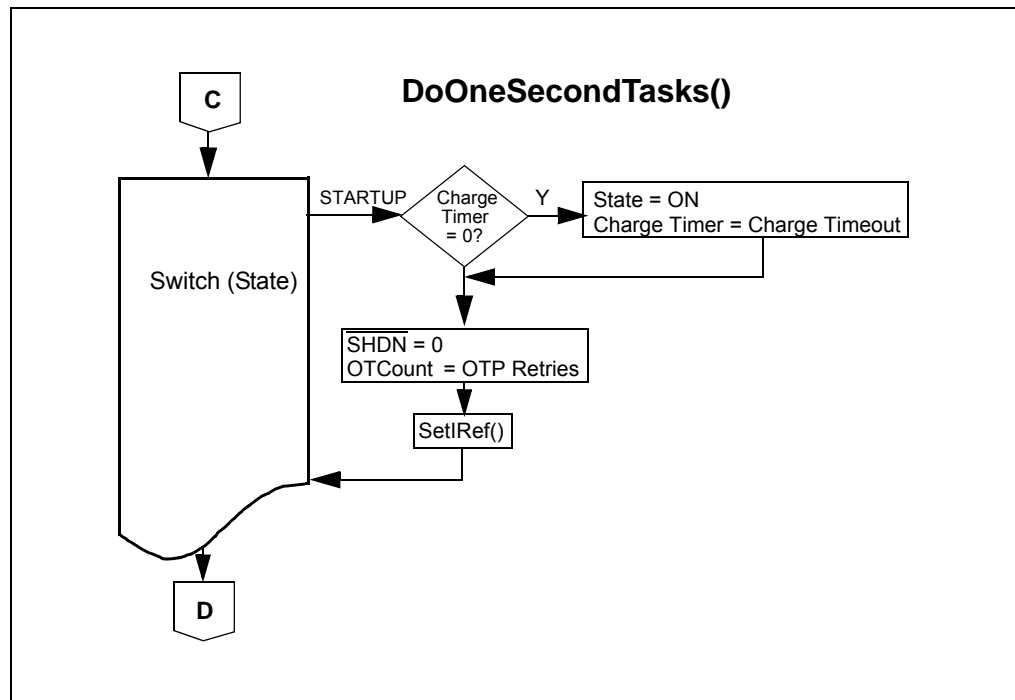
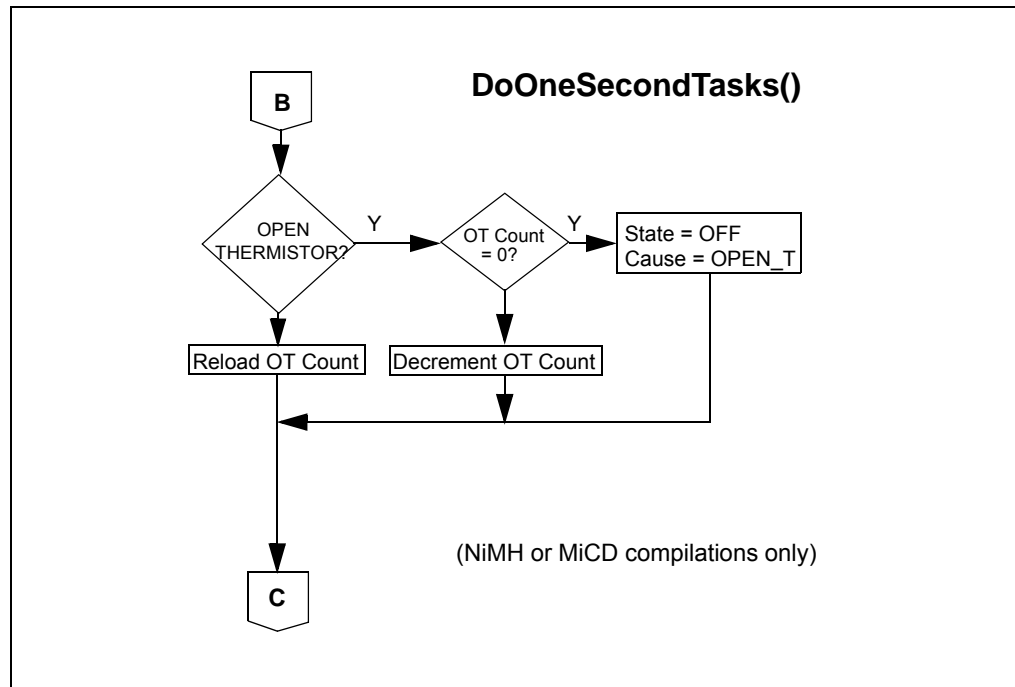

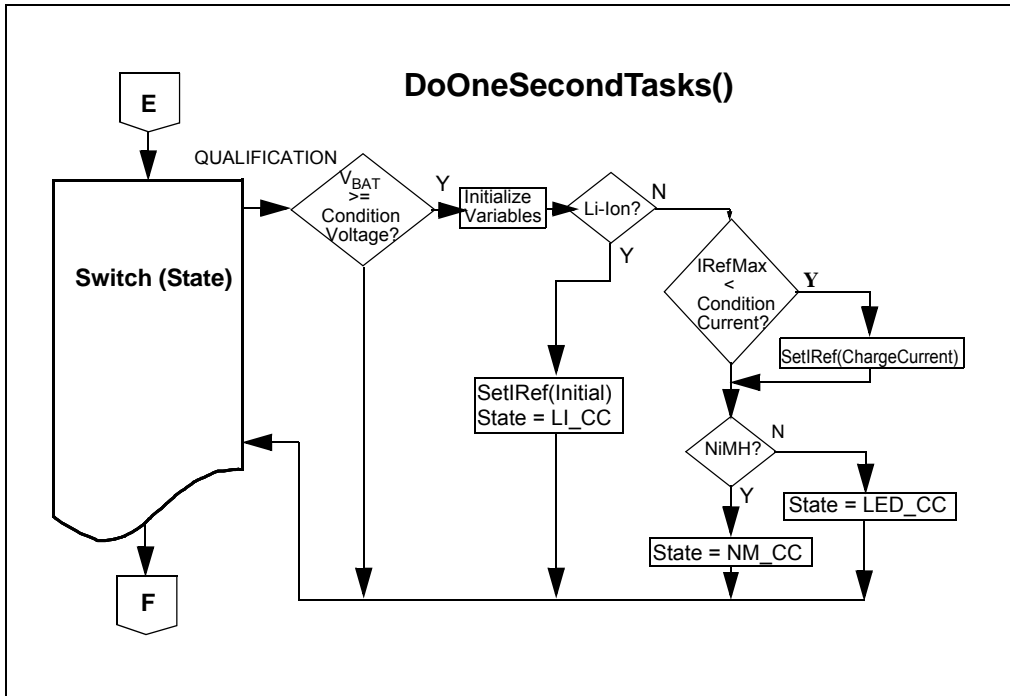
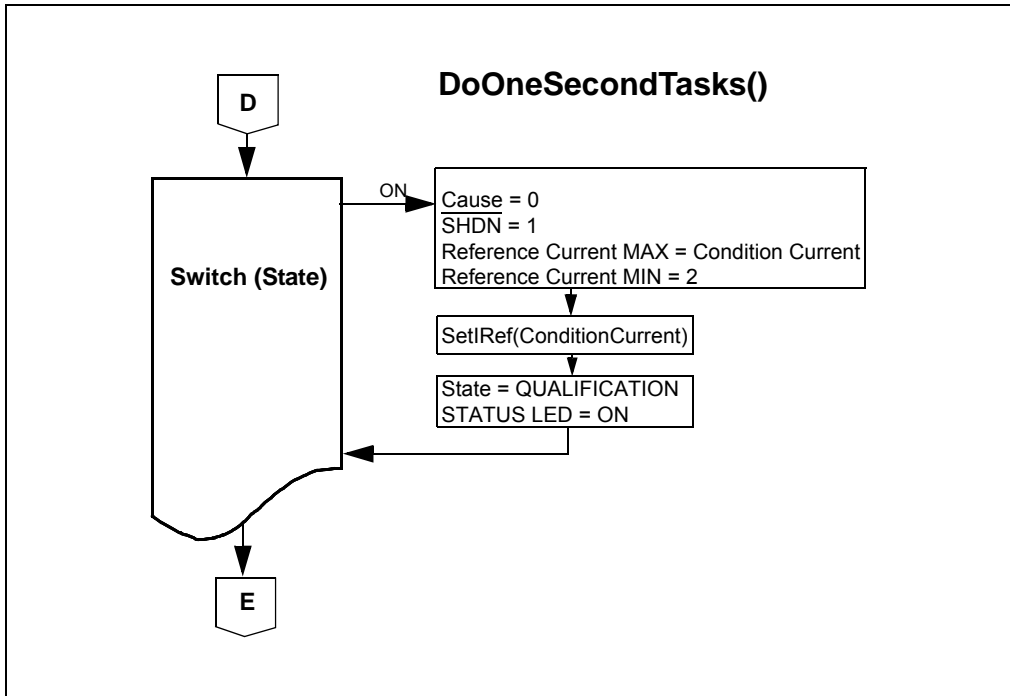

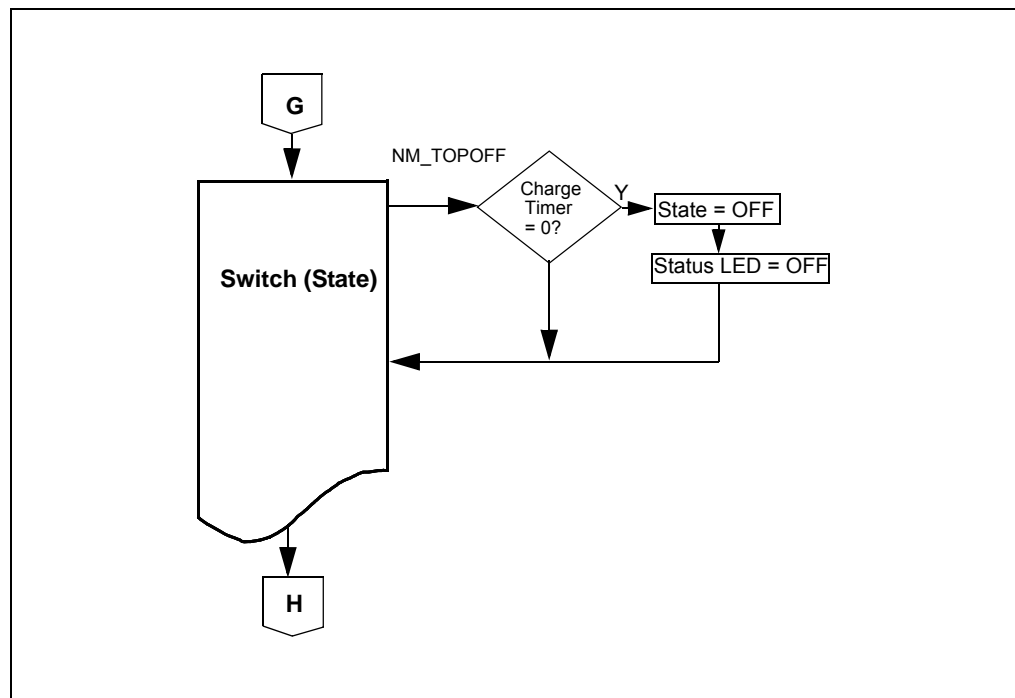
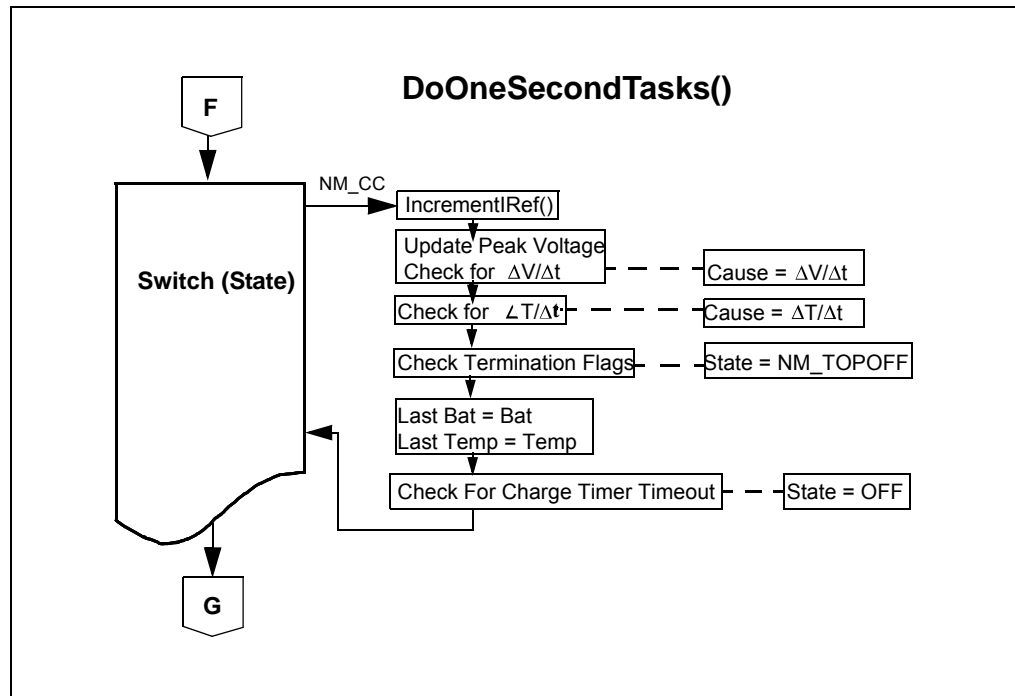

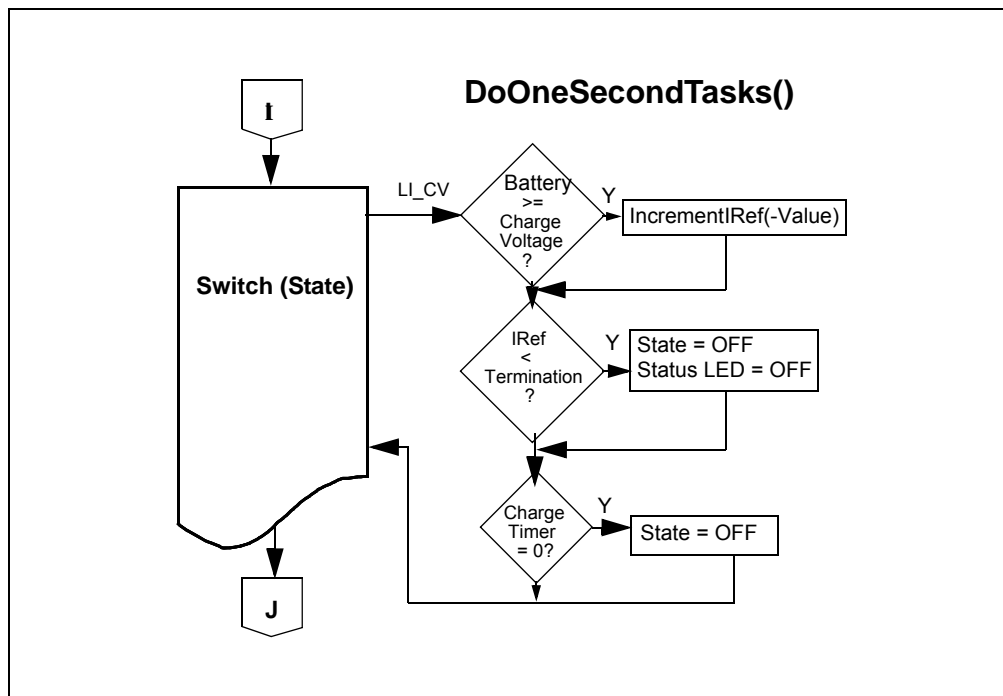
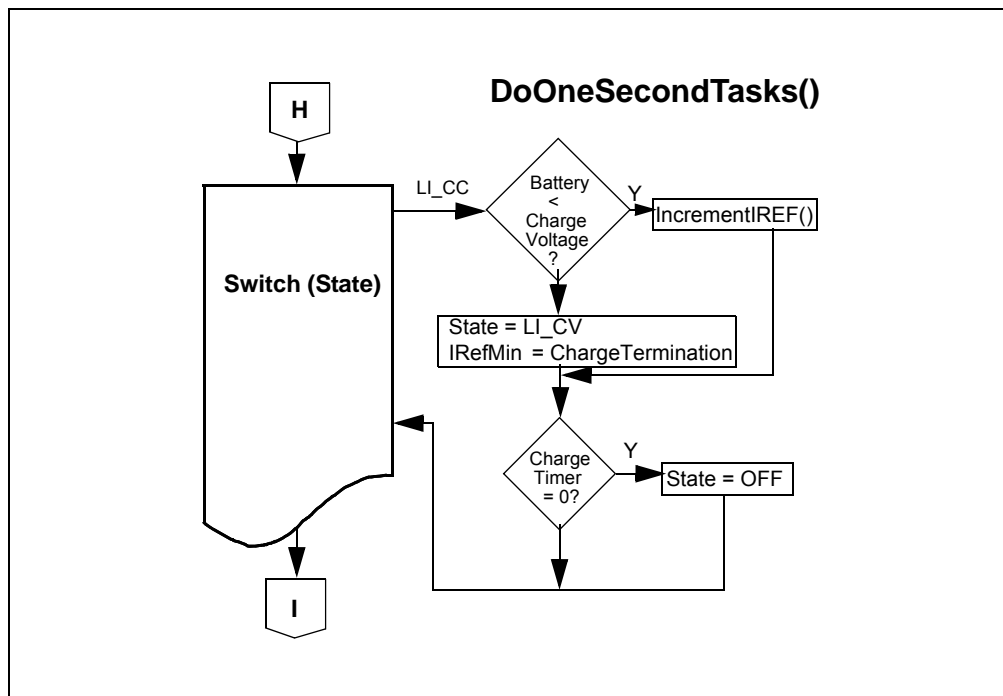

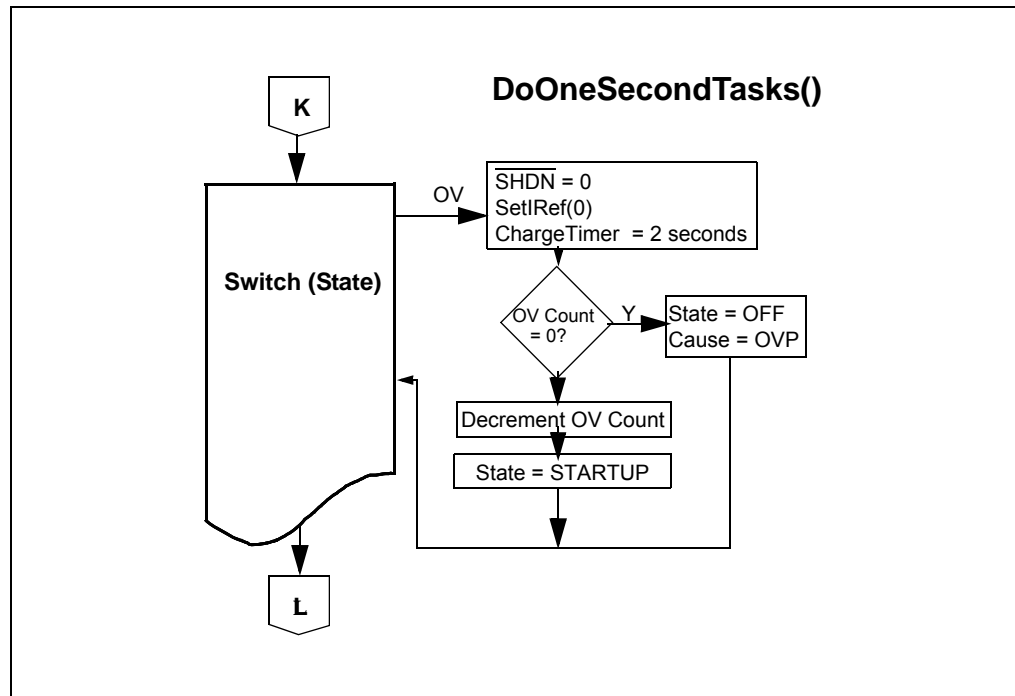
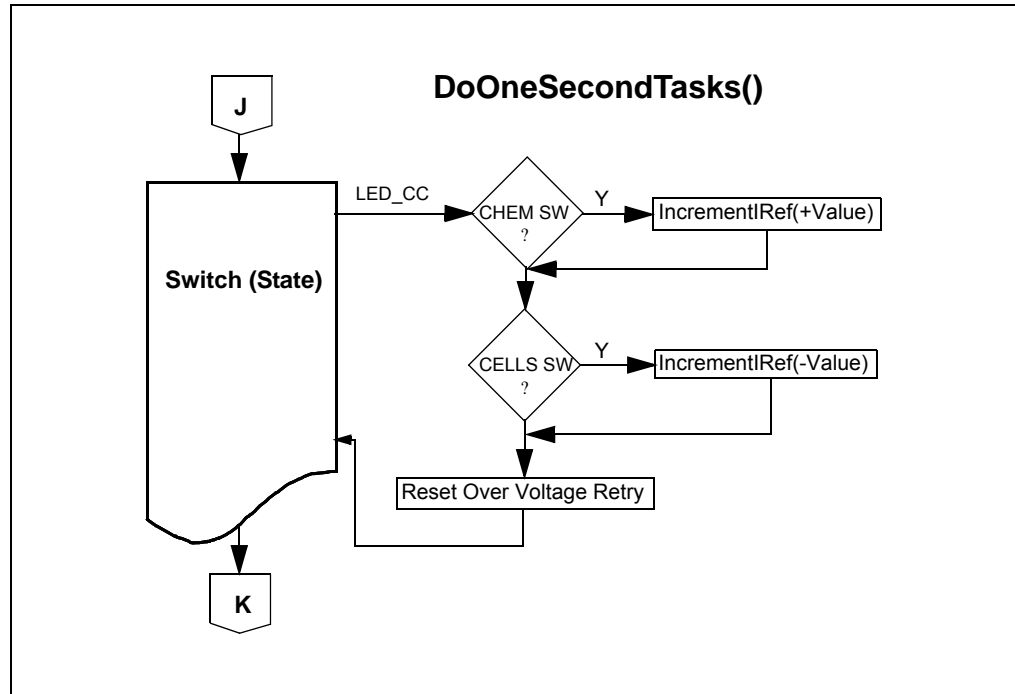

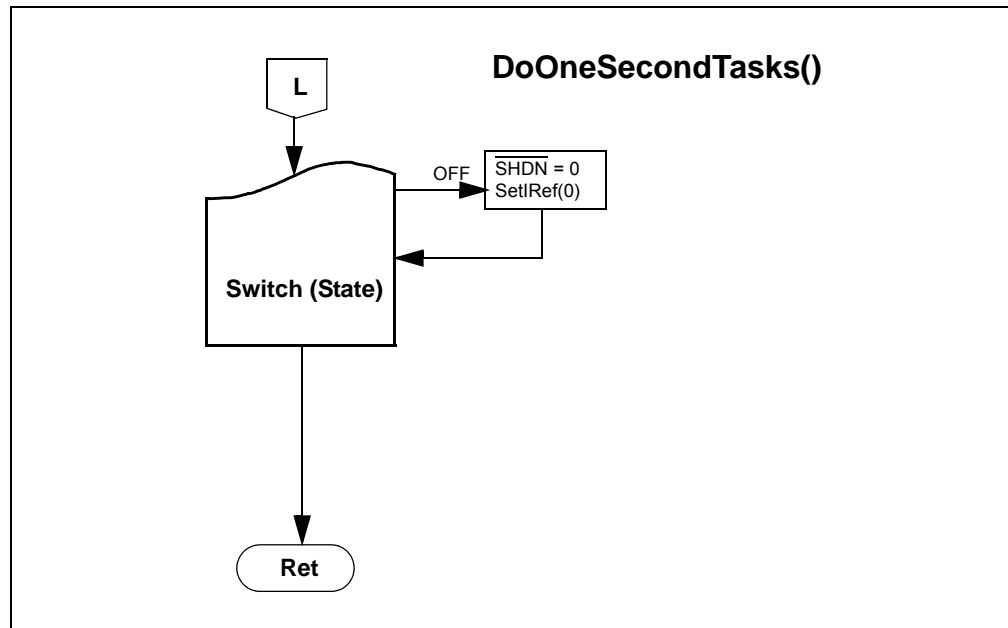

C.2 SELECTED SOFTWARE CONSTANTS AND DEFINITIONS

1. FOSC_KHZ = 8000
Microprocessor Oscillator Frequency in kHz.
2. CHARGER_SYSTEM = BUCK_BOOST_REF_DESIGN_BOARD
Selects charger system option to build. Multiple options can be created which each use a single header file containing parameters for that specific system.
Options for CHARGER_SYSTEM are:
MULTICHEMISTRY_REF_DESIGN_BOARD_102_00232
3. DVDT_TERMINATION = ENABLED
Used to mask NiMH termination caused by battery voltage DV/Dt. When DISABLED, allows the user to create complete charge profile by ignoring battery voltage termination.
4. DTDt_TERMINATION = ENABLED
Used to mask NiMH termination caused by battery temperature DT/Dt. When DISABLED, allows the user to create complete charge profile by ignoring battery temperature termination. Termination due to battery overtemperature is always enabled.
5. LION_SUPPORT = ENABLED
Enables support for Lithium Ion batteries.
6. NIMH_SUPPORT = ENABLED
Enable support for Nickel Metal Hydride batteries.
7. R24 = ((float)(39.6))
Voltage reference resistor divider highside resistor value (divider at PIC port C1).
8. R34 = ((float)(39.6))
Voltage reference resistor divider lowside resistor value (divider at PIC port C1).
9. MCP1631_ISIN_AMPLIFICATION = 10.0
MCP1631HV ISin Current Sense Input amplification.
10. R6 ((float)(0.22)) = Current Sense (ISin) Resistor
11. R7 ((float)(0.22)) = Current Sense (ISin) Resistor

12. $MCP1631_VSIN_RES_DIVIDER_VOLTAGE_SENSE = ((float)((100.0 + 301.0) / (100.0 + 301.0 + 348.0)))$
MCP1631 Voltage Sense (VSin) Resistor Divider (0.53538).
13. $BATTERY_MV_PER_BIT = ((float)(ADC_MV_PER_BIT / MCP1631_VSIN_RES_DIVIDER_VOLTAGE_SENSE))$
Battery voltage A/D value in millivolts per bit.
14. $LI_ION_OVER_VOLTAGE_CHARGE = ((int)(200.0/BATTERY_MV_PER_BIT))$
Cell overvoltage charge in mV (not averaged) = 50 mV to 200 mV.
15. $LI_ION_CONDITION_CURRENT = ((int)(200.0/BATTERY_MA_PER_BIT))$
Cell conditioning current in mA (0.2°C)
16. $LI_ION_CONDITION_VOLTAGE = ((int)(3000.0/BATTERY_MV_PER_BIT))$
Cell conditioning voltage in mV. Below this value is preconditioning area.
17. $LI_ION_CHARGE_CURRENT = ((int)(1200.0/BATTERY_MA_PER_BIT))$
Constant Current mode charging current in mA (0.5°C to 1°C).
18. $LI_ION_CHARGE_TERMINATION_CURRENT = ((int)(84.0/BATTERY_MA_PER_BIT))$
Charge termination current in mA (0.07°C).
19. $NIMH_NICD_OVER_VOLTAGE_CHARGE = ((int)(1800.0 / BATTERY_MV_PER_BIT))$
Cell overvoltage charge in mV (not averaged).
20. $NIMH_NICD_CONDITION_CURRENT = ((int)(140.0 / BATTERY_MA_PER_BIT))$
Cell conditioning current in mA (0.2°C to 0.3°C).
21. $NIMH_NICD_CONDITION_VOLTAGE = ((int)(900.0 / BATTERY_MV_PER_BIT))$
Cell conditioning voltage in mV. Below this value is preconditioning area.
22. $NIMH_NICD_CHARGE_CURRENT = ((int)(700.0 / BATTERY_MA_PER_BIT))$
Constant Current mode charging current in mA (0.5°C to 1°C).
23. $NIMH_NICD_CHARGE_TERMINATION_CURRENT = ((int)(35.0 / BATTERY_MA_PER_BIT))$
Charge termination current in mA (0.033°C to 0.05°C).
24. $NIMH_NICD_CHARGE_TOPOFF_TIME = (60 * 60)$
Charge Topoff Time in seconds during Charge Termination mode.
25. $NIMH_NICD_CHARGE_OVTEMP_SETPOINT = ((float)(THERMISTOR_OHMS_45C))$
Overtemperature Shutdown limit. Set to Thermistor ohms at desired shutdown temperature limit.
26. $NIMH_NICD_CHARGE_DTDT_60SEC_THRESHOLD = ((int)((0.3 + THERMISTOR_DEG_C_PER_BIT/2.0) / THERMISTOR_DEG_C_PER_BIT))$
Normal termination temperature change threshold in degrees Celsius over a 60 second span. (0.3 to 0.5 depending on charge rate).
27. $CHARGE_DVDT_PEAK_DETECT_COUNT = 3$
Sets termination based upon number of sequential 60 second battery voltage samples which have been lower than peak reading value.
28. $VSOUT_NOISE_LEVEL_IN_MV = ((float) 3.0)$
Noise level at VSOUT input to the A/D converter in mV. Approximately 3 - 5 mV of noise. Used to offset readings.
29. $DVDT_MV_PER_CELL = ((float) 6.0)$
Termination due to change in voltage per cell in millivolts over a 60 second interval. Termination Deadband for battery voltage dropoff after peak detect.

MCP1631HV Multi-Chemistry Battery Charger Reference Design

30. EE_CHEMISTRY_DEFAULT = Lilon
Default Chemistry.
31. EE_NUMBER_OF_CELLS_DEFAULT = 2
Default number of cells value.
32. EE_LION_CAL_VOLTAGE_DEFAULT = ((int)((float)(4200.00 / BATTERY_MV_PER_BIT)))
Default Lithium Ion battery calibration value.
33. EE_CHARGE_TIMEOUT_DEFAULT = (5*60*60)
Maximum charging time.
NiMH = Use (C rating in mAh/Charge Current) + 1hr Topoff + 0.25hr pre-condition)
*60 sec * 60 min
Lithium Ion = Use about 2.5 * (C rating in mAh/Charge Current) * 60 sec * 60 min
34. OSCILLATOR_DUTY_CYCLE = 25
Oscillator duty cycle in percent. Must be in 1/16th intervals due to 4 bit counter.
35. RS232_DATALOGGING = ENABLED
Set to ENABLE for logging data out to USART port and PICKit™ Serial Analyzer.
Set to DISABLED to remove logging code.
36. THERMISTOR_SUPPORT = ENABLED
Set to ENABLE for thermistor support. Used for NiMH and NiCD charging.
Set to DISABLED to remove thermistor code.
37. LED_DRIVER_SUPPORT = ENABLED
Set to ENABLE for LED driver support.
Set to DISABLED to remove LED driver code.
38. LED_DRIVER_OVER_VOLTAGE = ((int)(3600.0 / BATTERY_MV_PER_BIT))
Set this value to the voltage in mV that is the absolute limit of each single LED.
The system will go into overvoltage shutdown mode if the output voltage exceeds this value times the number of LED series connected cells being driven.
39. LED_DRIVER_CONDITION_CURRENT = ((int)(10.0/BATTERY_MA_PER_BIT))
LED conditioning (startup) current.
40. LED_DRIVER_CONDITION_VOLTAGE = ((int)(0.0/ BATTERY_MV_PER_BIT))
LED conditioning voltage is 0 volts. No conditioning required.
41. LED_DRIVER_CURRENT = ((int)(300.0 / BATTERY_MA_PER_BIT))
LED Driver current maximum value. This is the upper current limit value that the driver will deliver to the LED output.
42. LED_DRIVER_OVTEMP_SETPOINT = ((float)(THERMISTOR_OHMS_45C))
Optional LED overtemperature limit may be used to limit LED temperature.
Set LED_DRIVER_OVTEMP_SETPOINT to one of the Thermistor Ohms definitions for the desired shutdown temperature.
43. MAX_LED_CELLS = 2
Maximum number of 1W LED cells in series that will be driven by the driver output.

C.3 PIC16F883 PORT USAGE***/* Port A */***

PORTA.0 ADC_THERMISTOR_TEMPERATURE: Thermistor A/D input
PORTA.1 ADC_BATTERY_VOLTAGE: Battery Voltage A/D input
PORTA.4 SHDN: System Shutdown and Thermistor Supply Output
PORTA.5 ONOFF_SWITCH: On/Off' switch input
PORTA.6 NUMCELLS_SWITCH: Number of Cells' switch input
PORTA.7 CHEMISTRY_SWITCH: Chemistry' switch input

/* Port B */

PORTB.0 LIION_LED: Li-Ion' LED output
PORTB.1 NIMH_LED: NiMH' LED output
PORTB.2 LED_1_CELL: LS Bit '0' Hex LED display output
PORTB.3 LED_2_CELL: Bit '1' LED Hex display output
PORTB.4 LED_3_CELL: Bit '2' LED Hex display output
PORTB.5 LED_4_CELL: MS Bit '3' LED Hex display output
PORTB.6 In-Circuit Serial Programming CLOCK Line
PORTB.7 In-Circuit Serial Programming DATA Line

/* Port C */

PORTC.1 PWM_CURRENT_REF_OUT: Current Reference PWM output to MCP1631HV VREF input
PORTC.2 OSC_OUT: Oscillator PWM output to MCP1631HV OSCin input
PORTC.5 STATUS_LED: Status' LED output
PORTC.6 USART Transmit port. PICKIT™ Serial Analyzer interface.
PORTC.7 USART Receive port. PICKIT Serial Analyzer interface.

C.4 mikroElektronika's mikroC™ COMPILER STARTUP

1. Startup mikroC™ compiler (compiler not supplied, available at: <http://www.mikroe.com>).
2. From the toolbar, select "Project | Open Project".
3. Browse to the evaluation board source code path.
4. Select the existing project file, named "MCP1631HVBuckBoostBatteryChargerReferenceDesign.ppc".
5. From the toolbar, select : "Project | Edit Project". The page contains Processor, Clock, and Config settings.
6. From the toolbar, select: "Tools | Options". The page contains the compiler settings.
7. From the toolbar, select: "View | Code Explorer". This will show/hide the Code Explorer and Project Setup frames.
8. From the toolbar, select: "View | Messages". This will show/hide the Message frame at the bottom of the screen.
9. In the Project Setup Frame, click on the Project Summary tab. This shows the files for the project.
10. From the toolbar, select: "Project | Build". This will build the currently load project.
11. The compiler results will be displayed in the Message frame. Verify success.

C.5 MPLAB[®] AND PICKIT[™] 2 DEBUGGING EXERCISE

1. Startup MPLAB (not supplied, available at: <http://www.microchip.com>).
2. From the toolbar, select “File | Open Workspace”.
3. Browse to the evaluation board source code path.
4. Select the existing workspace file named “MCP1631HVBuckBoostBatteryChargerReferenceDesign.mcw” or create a new one.
5. Connect the PICKit 2 programmer to header J3 on the battery charger board. Align Pin 1 of the header with the Pin 1 mark on the programmer.
6. Set the bench power supply voltage control to minimum voltage output.
7. Turn on the power supply and set the output voltage to 8V. Turn off the power supply.
8. Connect the bench power supply to the battery charger board. Connect +V(8V) to J1-1 and –V (Ground) to J1-2.
9. Turn on the power supply.
10. From the toolbar, select “Debugger | Connect”. The debugger should find the PIC16F883 processor.
11. From the toolbar, select “File | Import”.
12. Browse to the source code path.
13. Select the existing project file named “MCP1631HVBuckBoostBatteryChargerReferenceDesign.hex”.
14. From the toolbar, select “Debugger | Program”. The debugger will program the PIC16F883 with the imported hex file.
15. From the toolbar, select “Debugger | Reset | Processor Reset”. This must always be done after programming.
16. From the toolbar, select “File | Open”.
17. In the “Files of type” text box, select “List Files (*.lst)”.
18. Click on “MCP1631HVBuckBoostBatteryChargerReferenceDesign.lst”.
19. Click on “Open”. This opens the mikroC[™] listing file for the project. Variable and Code addresses are at the end.
20. Scroll to the end of the listing file and locate the code label “L_main_1:”. Write down the function address.
21. In the “Program Memory” window, scroll down until you reach the same address as the “L_main_1:” function address. Right click on the line and set a breakpoint.
22. From the toolbar, select “Debugger | Run”. The debugger will stop at the breakpoint. Disable the breakpoint.
23. From the toolbar, select “Debugger | Run”. The debugger will continue.

When debugging the battery charger board, be careful when setting breakpoints. If the breakpoint occurs while the Voltage Reference PWM is HIGH, the V_{REF} voltage will rise to about 2.5V. The MCP1631HV will then attempt to supply the current for the given V_{REF} , which will be high (about $2.5V / 1.1 = 2.27A$). The current is limited by the V_{REF} signal which is in turn limited by the V_{REF} voltage divider resistor pair R24 and R34.

C.6 LAB EXERCISES

1. Startup the mikroC™ compiler and load the “MCP1631HVBuckBoostBatteryChargerReferenceDesign.ppc” if it does not load up automatically.
2. Startup MPLAB and load the “MCP1631HVBuckBoostBatteryChargerReferenceDesign.mcw” workspace if it does not start up automatically.

C.6.1 Li-Ion Only Exercise (single cell, 1200 mAh pack)

1. In the mikroC™ “Project Summary” frame, click on the “H files” branch to expand the ‘.H’ file list.
2. Double click on the “MULTICHEMISTRY_REF_DESIGN_BOARD_102_00232.H” file to open it.
3. Scroll through the header file and locate “#define LION_SUPPORT”. Set it to “ENABLED”.
4. Scroll through the header file and locate “#define NIMH_SUPPORT”. Set it to “DISABLED”.
5. Scroll through the header file and locate “#define LED_DRIVER_SUPPORT”. Set it to “DISABLED”.
6. Scroll down to the “#IF (LION_SUPPORT == ENABLED) section of the header file. The section contains Lithium Ion specific parameters. Note that there is a Nickel Metal Hydride and LED Driver section also.
7. Set the LI_ION_CONDITION_CURRENT to 200 mAh. (Conditioning mode current)
8. Set the LI_ION_CONDITION_VOLTAGE to 3000 mV. (Transition point from Conditioning to CC mode)
9. Set the LI_ION_CHARGE_CURRENT to 1200 mAh. (CC mode current)
10. Set the LI_ION_CHARGE_TERMINATION_CURRENT to 84 mAh. (0.07C – Termination Current for CV mode)
11. Save the file (File | Save).
12. Compile (Project | Build).
13. Open MPLAB and load the workspace if it is not already loaded. (File | Open Workspace) {Source Directory}\MCP1631HVBuckBoostBatteryChargerReferenceDesign.mcw
14. Import the new “MCP1631HVBuckBoostBatteryChargerReferenceDesign.hex” file. (File | Import)
15. Download the file (Debugger | Program) and reset the processor (Debugger | Reset | Processor Reset).
16. Run the new program (Debugger | Run).
17. Calibrate the Li-Ion Termination Voltage.
18. Disconnect and turn on the power supply and set the variable output voltage to 4.200V. Turn off the power supply.
19. Connect the fixed 12V supply (+) lead to the input connector (+) pin J1-1.
20. Connect the fixed 12V supply (-) lead to the input connector (-) pin J1-2.
21. Connect the 4.200V variable supply (+) lead to the battery connector (+) pin J2-1.
22. Connect the 4.200V variable supply (-) lead to the battery connector (-) pin J2-5.
23. Turn on the power supply.

24. Press and hold the “ON/OFF” button on the charger board until the LED’s flash (about 5 seconds). The board is now in Configuration Mode.
25. Press and release the “CHEM” button until the “Li-Ion” LED is on.
26. Press and release the “# CELLS” button until the “0” display LED is on and the “1,2,3” display LED’s are off.
27. Press and hold the “# CELLS” button on the charger board until the LED’s flash (about 5 seconds). The board is now calibrated to use the 4.200V as the Li-Ion battery voltage.
28. Press the “ON/OFF” button. The charger will exit Configuration mode.
29. Turn off and disconnect the power supply.
30. Reconnect the variable supply (+) lead to the input connector (+) pin J1-1.
31. Reconnect the variable supply (-) lead to the input connector (-) pin J1-2.
32. Connect the Li-Ion battery pack to the charger board J2 connector.
33. Turn on the supply and set the voltage to 8.0V (any voltage between 6V and 12V is good).
34. Press the “ON/OFF” button. The charger will start charging the battery.
35. Press the “CHEM” button to display the current charger state in HEX. “0” LED is the LS Bit.
36. Press the “# CELLS” button to display the termination cause. No LED means no premature termination.
37. Using an oscilloscope, refer to **A.2 “Board – Schematic”** and **A.3 “Board – Top Silk Layer”** and probe the following components:
 - V_{REF} = TP3
 - PWM = TP4
 - Oscillator = TP5
 - $V_{S_{OUT}}$ = TP6
 - Slope Compensation = TP7
 - Temperature = TP8 (if used)
 - FB = TP9
 - Drain Voltage = TP10
 - Output Voltage = TP11
38. Press the “ON/OFF” button. The charger will stop charging the battery.

C.6.2 NiMH Lab Exercise (3 Cell, 700 mAh pack, with thermistor)

1. In the mikroC™ “Project Summary” frame, click on the “H files” branch to expand the ‘.H’ file list.
2. Double click on the “MULTICHEMISTRY_REF_DESIGN_BOARD_102_00232.H” file to open it.
3. Scroll through the header file and locate “#define LION_SUPPORT”. Set it to “DISABLED”.
4. Scroll through the header file and locate “#define NIMH_SUPPORT”. Set it to “ENABLED”.
5. Scroll through the header file and locate “#define LED_DRIVER_SUPPORT”. Set it to “DISABLED”.
6. Scroll down to the “#IF (NIMH_SUPPORT == ENABLED)” section of the header file. The section contains Nickel Metal Hydride and NiCd specific parameters.
7. Set the NIMH_NICD_CONDITION_CURRENT to 140 mAh. (0.2C Conditioning mode current)
8. Set the NIMH_NICD_CONDITION_VOLTAGE to 900 mV. (Transition point from Conditioning to CC mode)
9. Set the NIMH_NICD_CHARGE_CURRENT to 700 mAh. (1.0C Constant Current Charge)
10. Set the NIMH_NICD_CHARGE_TERMINATION_CURRENT to 84 mAh. (0.07C – Termination Current for CV mode)
11. Set the DVDT_MV_PER_CELL to 6.0. (Termination Voltage change per cell per minute in millivolts)
12. Set the NIMH_NICD_CHARGE_DTD_60SEC_THRESHOLD to 0.3. (Termination Temperature change per minute in degrees Celsius)
13. Set the NIMH_NICD_CHARGE_OVTEMP_SETPOINT to THERMISTOR_OHMS_45C. (Termination temperature for safety)
14. Save the file (File | Save).
15. Compile (Project | Build).
16. Open MPLAB and load the workspace if it is not already loaded. (File | Open Workspace) MCP1631HVBuckBoostBatteryChargerReferenceDesign.mcw
17. Import the new “MCP1631HVBuckBoostBatteryChargerReferenceDesign.hex” file. (File | Import)
18. Download the file (Debugger | Program) and reset the processor (Debugger | Reset | Processor Reset).
19. Run the new program (Debugger | Run).
20. Turn on the power supply and set the output voltage to 8V. Turn off the power supply.
21. Connect the variable 8V supply (+) lead to the input connector (+) pin J1-1.
22. Connect the variable 8V supply (-) lead to the input connector (-) pin J1-2.
23. Connect the NiMH battery pack to the charger board J2 connector.
24. Turn on the variable 8V supply.
25. Press and hold the “ON/OFF” button on the charger board until the LED’s flash (about 5 seconds). The board is now in Configuration Mode.
26. Press and release the “CHEM” button until the “NiMH” LED is on.

27. Press and release the “# CELLS” button until the “0” and “1” “Display” LED’s are on and the “2” and “3” “Display” LED’s are off. The LED display now displays “3” in Hexadecimal.
28. Press the “ON/OFF” button. The charger will exit Configuration mode.
29. Press the “ON/OFF” button. The charger will start charging the battery.
30. Press the “CHEM” button to display the current charger state in HEX. “0” “Display” LED is LS Bit.
31. Press the “# CELLS” button to display the termination cause. No LED means no premature termination.
32. Using an oscilloscope, refer to Appendices **A.2 “Board – Schematic”** and **A.3 “Board – Top Silk Layer”** and probe the following components:
 - V_{REF} = TP3
 - PWM = TP4
 - Oscillator = TP5
 - V_{SOUT} = TP6
 - Slope Compensation = TP7
 - Temperature = TP8
 - FB = TP9
 - Drain Voltage = TP10
 - Output Voltage = TP11
33. Press the “ON/OFF” button. The charger will stop charging the battery.

C.6.3 LED Driver Lab Exercise (Two 1 Watt LED's in series)

1. In the mikroC™ “Project Summary” frame, click on the “H files” branch to expand the ‘.H’ file list.
2. Double click on the “MULTICHEMISTRY_REF_DESIGN_BOARD_102_00232.H” file to open it.
3. Scroll through the header file and locate “#define LION_SUPPORT”. Set it to “DISABLED”.
4. Scroll through the header file and locate “#define NIMH_SUPPORT”. Set it to “DISABLED”.
5. Scroll through the header file and locate “#define LED_DRIVER_SUPPORT”. Set it to “ENABLED”.
6. Scroll down to the “#IF (LED_DRIVER_SUPPORT == ENABLED) section of the header file. The section contains LED Driver specific parameters.
7. Set the LED_DRIVER_OVER_VOLTAGE to 3600 mV. (Overvoltage Shutdown value per LED).
8. Set the LED_DRIVER_CONDITION_CURRENT to 10 mAh.
9. Set the LED_DRIVER_CONDITION_VOLTAGE to 0 mV. (Skips Conditioning State, not needed).
10. Set the LED_DRIVER_CURRENT to 300 mAh. (Constant Current mode).
11. Save the file (File | Save).
12. Compile (Project | Build).
13. Open MPLAB and load the workspace if it is not already loaded. (File | Open Workspace) MCP1631HVBuckBoostBatteryChargerReferenceDesign.mcw.
14. Import the new “MCP1631HVBuckBoostBatteryChargerReferenceDesign.hex” file. (File | Import)
15. Download the file (Debugger | Program) and reset the processor (Debugger | Reset | Processor Reset).
16. Run the new program (Debugger | Run).
17. Turn on the power supply and set the output voltage to 8V. Turn off the power supply.
18. Connect the variable 8V supply (+) lead to the input connector (+) pin J1-1.
19. Connect the variable 8V supply (-) lead to the input connector (-) pin J1-2.
20. Connect the two 1 watt LED's in series to the charger board J2 connector.
21. Turn on the variable 8V supply.
22. Press and hold the “ON/OFF” button on the charger board until the LED's flash (about 5 seconds). The board is now in Configuration Mode.
23. Press and release the “CHEM” button until both the “NiMH” and “Lilon” LEDs are on.
24. Press and release the “# CELLS” button until the “1” “Display” LED is on and the “0”, “2” and “3” “Display” LED's are off. The LED display now displays “2” in Hexadecimal.
25. Press the “ON/OFF” button. The charger will exit Configuration mode.
26. Press the “ON/OFF” button. The charger will start charging the battery.
27. Press the “CHEM” button to display the current charger state in HEX. “0” “Display” LED is LS Bit.
28. Press the “# CELLS” button to display the termination cause. No LED means no premature termination.

29. Using an oscilloscope, refer to Appendices **A.2 “Board – Schematic”** and **A.3 “Board – Top Silk Layer”** and probe the following components:
- V_{REF} = TP3
 - PWM = TP4
 - Oscillator = TP5
 - $V_{S_{OUT}}$ = TP6
 - Slope Compensation = TP7
 - Temperature = TP8 (if used)
 - FB = TP9
 - Drain Voltage = TP10
 - Output Voltage = TP11
30. Press the “ON/OFF” button. The charger will stop charging the battery.

MCP1631HV Multi-Chemistry Battery Charger Reference Design

NOTES:

Appendix D. Design Example

D.1 DESIGN EXAMPLE

D.1.1 Design Parameters:

- $P_{OUT} = 10W$ (typical)
- $V_{IN} = 6V$ to $16V$ for MCP1631HV. Choose $V_{IN} = 6V$ for worst case (WC).
- $V_{OUT} = 8.4V$ for two Li-Ion batteries or $6.6V$ for four NiMH batteries
- $I_{OUT} = 1.5A$ for 4 NiMH batteries. Choose $\Delta I_L = 20\%$, $I_{OUT} = 300$ mA.
- $\eta =$ Switcher Efficiency @ 80% (typical)
- $V_F =$ Schottky Diode Drop @ $0.35V$ (typical)
- $I_{IN_WC} = I_{OUT} * V_{OUT_WC} / (V_{IN_WC} * \eta) = 1.5A * 6.6V / (6V * 0.8) = 2.06A$
- $F_{OSC} = 500$ kHz, $T_{SWITCH} = 1/F_{SWITCH} = 2$ μs
- $D_{OSC} = 25\%$, $t_{OSC_ON} = 0.5$ μs , $t_{OSC_OFF} = 1.5$ μs
- Choose C20 (Artificial Ramp) = 1500 pF

D.1.2 Design:

- Duty Cycle (D) = $((V_{OUT} + V_F)/\eta) / (((V_{OUT} + V_F)/\eta) + V_{IN})$
 $= ((8.4V + 0.35)/0.8) / (((8.4V + 0.35)/0.8) + 6V)$
 $= 65\%$ (worst case is two Li-Ion batteries)
- $t_{ON} = D * 1/F_{SWITCH} = 0.65/500$ kHz = 1.3 μs
- $t_{OFF} = T_{SWITCH} - t_{ON} = 2$ $\mu s - 1.3$ $\mu s = 0.7$ μs
- $L = V_{IN} * D * T_{SWITCH} / \Delta I_L = 6V * 0.65 * 2$ $\mu s / 300$ mA = 26 μH .
 For SEPIC coupled inductor, use $1/2$ L because V_{IN} "sees" 2 inductors.
 $L_{COUPLED} = 26$ $\mu H / 2 = 13$ μH . Choose 10 μH as standard value.
- $\Delta I_L = 2 * V_{IN} * D * T_{SWITCH} / (4 * L_{COUPLED}) = 2 * 6V * 0.65 * 2$ $\mu s / (4 * 10$ $\mu H)$
 $\Delta I_L \cong 390$ mA
- $\Delta I_{IN} = \Delta I_L = 390$ mA
- $I_{IN} = I_{OUT} * V_{OUT} / (V_{IN} * \eta) = 1.5A * 6.6V / (6V * 0.8) = 2.06A$
 $I_{IN_PEAK} = I_{IN} + 1/2 \Delta I_L = 2.06A + 0.195A = 2.26A$
- $P_{OUT} = V_{OUT} * I_{OUT} = 6.6V * 1.5A = 9.9W$

D.1.3 Slope Compensation:

- $M_{Artificial Ramp} = \Delta I_L * R_{SENSE} / t_{OSC_FF}$
 $= 390$ mA * $0.11\Omega / 1.5$ $\mu s = 0.0429V / 1.5$ μs
 But the ramp divider is $(R10 + R11) / (R10 + R11 + R35)$
 $= (1k + 1k) / (1k + 1k + 20k) = 2k / 22k = 1/11$
 $= (0.0429V / 1.5$ $\mu s) / (1/11) = 471.9$ mV / 1.5 μs
- $\tau_{Artificial Ramp} (R33 \& C20) -$ Using $V_{OUT} = V_{IN} (1 - e^{-T/\tau})$
 $= -t_{OFF} / (\ln(1 - (V_{OUT}/V_{IN})))$
 $= -1.5$ $\mu s / (\ln(1 - (0.4719V/5.0V)))$
 $= -1.5$ $\mu s / \ln(0.90562) = 15.13$ μs

- $R_{\text{Artificial Ramp}} = \tau_{\text{Artificial Ramp}}/C_{\text{Artificial Ramp}} = 15.13 \mu\text{s}/1500 \text{ pF}$
= 10 k Ω (max), use around 5.6 k Ω to 9.1 k Ω for tolerances
An R value of 5.6 k Ω was used for the Eval Board.

D.1.4 Coupling Capacitor:

- SW_{ON} , $D = 25\%$, $t = 0.5 \mu\text{s}$
 $I_{\text{RIPPLE}} = t_{\text{ON}} * 2V_{\text{IN}}/4L = 0.5 \mu\text{s} * (2)(6\text{V})/(4*10 \mu\text{H}) = 0.150\text{A}$
 $I_1 = I_{\text{OUT}} - 1/2 I_{\text{RIPPLE}} = 1.5\text{A} - 0.075\text{A} = 1.425\text{A}$
 $I_2 = I_{\text{OUT}} + 1/2 I_{\text{RIPPLE}} = 1.5\text{A} + 0.075\text{A} = 1.575\text{A}$
 $I_{\text{RMS_ON}} = \text{SQRT}(D * (I_1^2 + I_1 * I_2 + I_2^2)/3)$ (for a trapezoidal waveform)
= $\text{SQRT}(0.25 * (1.425^2 + 1.425 * 1.575 + 1.575^2)/3)$
= 0.750A
- SW_{OFF} , $D = 75\%$, $t = 1.5 \mu\text{s}$
 $I_{\text{RIPPLE}} = t_{\text{OFF}} * 2V_{\text{IN}}/4L = 1.5 \mu\text{s} * (2)(6\text{V})/(4*10 \mu\text{H}) = 0.450\text{A}$
 $I_1 = -I_{\text{IN_WC}} - 1/2 I_{\text{RIPPLE}} = -2.06\text{A} - 0.225\text{A} = -2.285\text{A}$
 $I_2 = -I_{\text{IN_WC}} + 1/2 I_{\text{RIPPLE}} = -2.06\text{A} + 0.225\text{A} = -1.835\text{A}$
 $I_{\text{RMS_OFF}} = \text{SQRT}(D * (I_1^2 + I_1 * I_2 + I_2^2)/3)$
= $\text{SQRT}(0.75 * [-2.285^2 + (-2.285 * (-1.835)) + (-1.835)^2]/3)$
= 1.79A
- $I_{\text{RMS}} = \text{SQRT}(I_{\text{RMS_ON}}^2 + I_{\text{RMS_OFF}}^2)$
= $\text{SQRT}(0.750^2 + 1.79^2)$
= 1.94A
- Worst-Case Capacitor Current is 1.94A.
Choose a capacitor that is rated for at least the worst-case current.

NOTES:



WORLDWIDE SALES AND SERVICE

AMERICAS

Corporate Office
2355 West Chandler Blvd.
Chandler, AZ 85224-6199
Tel: 480-792-7200
Fax: 480-792-7277
Technical Support:
<http://support.microchip.com>
Web Address:
www.microchip.com

Atlanta
Duluth, GA
Tel: 678-957-9614
Fax: 678-957-1455

Boston
Westborough, MA
Tel: 774-760-0087
Fax: 774-760-0088

Chicago
Itasca, IL
Tel: 630-285-0071
Fax: 630-285-0075

Dallas
Addison, TX
Tel: 972-818-7423
Fax: 972-818-2924

Detroit
Farmington Hills, MI
Tel: 248-538-2250
Fax: 248-538-2260

Kokomo
Kokomo, IN
Tel: 765-864-8360
Fax: 765-864-8387

Los Angeles
Mission Viejo, CA
Tel: 949-462-9523
Fax: 949-462-9608

Santa Clara
Santa Clara, CA
Tel: 408-961-6444
Fax: 408-961-6445

Toronto
Mississauga, Ontario,
Canada
Tel: 905-673-0699
Fax: 905-673-6509

ASIA/PACIFIC

Asia Pacific Office
Suites 3707-14, 37th Floor
Tower 6, The Gateway
Harbour City, Kowloon
Hong Kong
Tel: 852-2401-1200
Fax: 852-2401-3431

Australia - Sydney
Tel: 61-2-9868-6733
Fax: 61-2-9868-6755

China - Beijing
Tel: 86-10-8528-2100
Fax: 86-10-8528-2104

China - Chengdu
Tel: 86-28-8665-5511
Fax: 86-28-8665-7889

China - Hong Kong SAR
Tel: 852-2401-1200
Fax: 852-2401-3431

China - Nanjing
Tel: 86-25-8473-2460
Fax: 86-25-8473-2470

China - Qingdao
Tel: 86-532-8502-7355
Fax: 86-532-8502-7205

China - Shanghai
Tel: 86-21-5407-5533
Fax: 86-21-5407-5066

China - Shenyang
Tel: 86-24-2334-2829
Fax: 86-24-2334-2393

China - Shenzhen
Tel: 86-755-8203-2660
Fax: 86-755-8203-1760

China - Wuhan
Tel: 86-27-5980-5300
Fax: 86-27-5980-5118

China - Xiamen
Tel: 86-592-2388138
Fax: 86-592-2388130

China - Xian
Tel: 86-29-8833-7252
Fax: 86-29-8833-7256

China - Zhuhai
Tel: 86-756-3210040
Fax: 86-756-3210049

ASIA/PACIFIC

India - Bangalore
Tel: 91-80-3090-4444
Fax: 91-80-3090-4080

India - New Delhi
Tel: 91-11-4160-8631
Fax: 91-11-4160-8632

India - Pune
Tel: 91-20-2566-1512
Fax: 91-20-2566-1513

Japan - Yokohama
Tel: 81-45-471- 6166
Fax: 81-45-471-6122

Korea - Daegu
Tel: 82-53-744-4301
Fax: 82-53-744-4302

Korea - Seoul
Tel: 82-2-554-7200
Fax: 82-2-558-5932 or
82-2-558-5934

Malaysia - Kuala Lumpur
Tel: 60-3-6201-9857
Fax: 60-3-6201-9859

Malaysia - Penang
Tel: 60-4-227-8870
Fax: 60-4-227-4068

Philippines - Manila
Tel: 63-2-634-9065
Fax: 63-2-634-9069

Singapore
Tel: 65-6334-8870
Fax: 65-6334-8850

Taiwan - Hsin Chu
Tel: 886-3-572-9526
Fax: 886-3-572-6459

Taiwan - Kaohsiung
Tel: 886-7-536-4818
Fax: 886-7-536-4803

Taiwan - Taipei
Tel: 886-2-2500-6610
Fax: 886-2-2508-0102

Thailand - Bangkok
Tel: 66-2-694-1351
Fax: 66-2-694-1350

EUROPE

Austria - Wels
Tel: 43-7242-2244-39
Fax: 43-7242-2244-393

Denmark - Copenhagen
Tel: 45-4450-2828
Fax: 45-4485-2829

France - Paris
Tel: 33-1-69-53-63-20
Fax: 33-1-69-30-90-79

Germany - Munich
Tel: 49-89-627-144-0
Fax: 49-89-627-144-44

Italy - Milan
Tel: 39-0331-742611
Fax: 39-0331-466781

Netherlands - Drunen
Tel: 31-416-690399
Fax: 31-416-690340

Spain - Madrid
Tel: 34-91-708-08-90
Fax: 34-91-708-08-91

UK - Wokingham
Tel: 44-118-921-5869
Fax: 44-118-921-5820

Looking for pricing, stock, or lifecycle information?

Click below to explore more details on WIN SOURCE:

- ⊖ [View MCP1631-E/ST on WIN SOURCE](#)
- ⊖ [Microchip Technology](#) Information

Optimize Your Supply Chain with WIN SOURCE Solutions

- ✓ Global Sourcing Solution
- ✓ Obsolete Management
- ✓ Cost Control Management
- ✓ Shortage Management
- ✓ Alternative Solution
- ✓ Excess Inventory Management