



# THE DATASHEET OF STF7N52DK3



## N-channel 525 V, 0.95 $\Omega$ typ., 6 A, SuperFREDmesh3™ Power MOSFETs in DPAK and TO-220FP packages



DPAK

TO-220FP

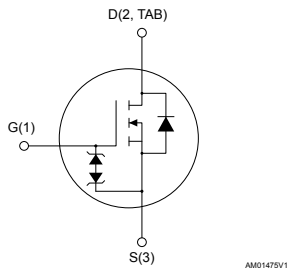

AM01475V1

### Features

Order codes	$V_{DS}$	$R_{DS(on)}$ max.	$I_D$	$P_{TOT}$
STD7N52DK3	525 V	1.15 $\Omega$	6 A	90 W
STF7N52DK3				25 W

- 100% avalanche tested
- Extremely high dv/dt capability
- Gate charge minimized
- Very low intrinsic capacitance
- Improved diode reverse recovery characteristics
- Zener-protected

### Applications

- Switching applications

### Description

These devices are developed using the revolutionary N-channel SuperFREDmesh3™ technology. They associate all advantages of reduced on-resistance, Zener gate protection and very high dv/dt capability with a fast body-drain recovery diode. Such series complements the FDmesh™ advanced technology.

#### Product status links

[STD7N52DK3](#)
[STF7N52DK3](#)

#### Product summary

##### STD7N52DK3

Order code	STD7N52DK3
Marking	7N52DK3
Package	DPAK
Packing	Tape and reel

##### STF7N52DK3

Order code	STF7N52DK3
Marking	7N52DK3
Package	TO-220FP
Packing	Tube

# 1 Electrical ratings

**Table 1. Absolute maximum ratings**

Symbol	Parameter	Value		Unit
		DPAK	TO-220FP	
$V_{DS}$	Drain-source voltage	525		V
$V_{GS}$	Gate-source voltage	±30		V
$I_D$	Drain current (continuous) at $T_C = 25\text{ °C}$	6	6 <sup>(1)</sup>	A
	Drain current (continuous) at $T_C = 100\text{ °C}$	4	4 <sup>(1)</sup>	A
$I_{DM}^{(2)}$	Drain current (pulsed)	24	24 <sup>(1)</sup>	A
$P_{TOT}$	Total dissipation at $T_C = 25\text{ °C}$	90	25	W
$I_{AR}^{(3)}$	Avalanche current, repetitive or non-repetitive	3		A
$E_{AS}^{(4)}$	Single pulse avalanche energy	110		mJ
$dv/dt^{(5)}$	Peak diode recovery voltage slope	20		V/ns
$di/dt^{(5)}$	Diode reverse recovery current slope	400		A/ns
$V_{ISO}$	Insulation withstand voltage (RMS) from all three leads to external heat sink ( $t = 1\text{ s}$ , $T_C = 25\text{ °C}$ )		2.5	kV
$T_{stg}$	Storage temperature range	-55 to 150		°C
$T_J$	Operating junction temperature range			

1. This value is limited by maximum junction temperature.
2. Pulse width is limited by safe operating area.
3. Pulse width is limited by  $T_{Jmax}$ .
4. Starting  $T_J = 25\text{ °C}$ ,  $I_D = I_{AR}$ ,  $V_{DD} = 50\text{ V}$
5.  $I_{SD} \leq 6\text{ A}$ ,  $V_{DS(peak)} \leq V_{(BR)DSS}$ ,  $V_{DD} = 80\% V_{(BR)DSS}$

**Table 2. Thermal data**

Symbol	Parameter	Value		Unit
		DPAK	TO-220FP	
$R_{thj-case}$	Thermal resistance junction-case	1.39	5	°C/W
$R_{thj-pcb}^{(1)}$	Thermal resistance junction-pcb	50		°C/W
$R_{thj-amb}$	Thermal resistance junction-ambient		62.5	°C/W

1. When mounted on an 1-inch<sup>2</sup> FR-4, 2oz Cu board.

## 2 Electrical characteristics

( $T_C = 25\text{ °C}$  unless otherwise specified)

**Table 3. On/off states**

Symbol	Parameter	Test conditions	Min.	Typ.	Max.	Unit
$V_{(BR)DSS}$	Drain-source breakdown voltage	$I_D = 1\text{ mA}$ , $V_{GS} = 0\text{ V}$	525			V
$I_{DSS}$	Zero gate voltage drain current	$V_{GS} = 0\text{ V}$ , $V_{DS} = 525\text{ V}$			1	$\mu\text{A}$
		$V_{GS} = 0\text{ V}$ , $V_{DS} = 525\text{ V}$ , $T_C = 125\text{ °C}^{(1)}$			50	$\mu\text{A}$
$I_{GSS}$	Gate body leakage current	$V_{GS} = \pm 20\text{ V}$ , $V_{DS} = 0\text{ V}$			$\pm 10$	$\mu\text{A}$
$V_{GS(th)}$	Gate threshold voltage	$V_{DS} = V_{GS}$ , $I_D = 50\text{ }\mu\text{A}$	3	3.75	4.5	V
$R_{DS(on)}$	Static drain-source on-resistance	$V_{GS} = 10\text{ V}$ , $I_D = 3\text{ A}$		0.95	1.15	$\Omega$

1. Defined by design, not subject to production test.

**Table 4. Dynamic**

Symbol	Parameter	Test conditions	Min.	Typ.	Max.	Unit
$C_{iss}$	Input capacitance	$V_{DS} = 50\text{ V}$ , $f = 1\text{ MHz}$ , $V_{GS} = 0\text{ V}$	-	870	-	$\text{pF}$
$C_{oss}$	Output capacitance			70		
$C_{rss}$	Reverse transfer capacitance			13		
$C_{oss(tr)}^{(1)}$	Time-related equivalent output capacitance	$V_{DS} = 0\text{ to }420\text{ V}$ , $V_{GS} = 0\text{ V}$	-	53	-	$\text{pF}$
$C_{oss(er)}^{(2)}$	Energy-related equivalent output capacitance			74		
$R_G$	Intrinsic gate resistance	$f = 1\text{ MHz}$ open drain	-	3.5	-	$\Omega$
$Q_g$	Total gate charge	$V_{DD} = 420\text{ V}$ , $I_D = 6\text{ A}$ , $V_{GS} = 0\text{ to }10\text{ V}$ (see Figure 17. Test circuit for gate charge behavior)	-	33	-	$\text{nC}$
$Q_{gs}$	Gate-source charge			5		
$Q_{gd}$	Gate-drain charge			19		

1.  $C_{oss(tr)}$  is defined as the constant equivalent capacitance giving the same charging time as  $C_{oss}$  when  $V_{DS}$  increases from 0 to 420 V.

2.  $C_{oss(er)}$  is defined as the constant equivalent capacitance giving the same stored energy as  $C_{oss}$  when  $V_{DS}$  increases from 0 to 420 V.

**Table 5. Switching times**

Symbol	Parameter	Test conditions	Min.	Typ.	Max.	Unit
$t_{d(on)}$	Turn-on delay time	$V_{DD} = 260\text{ V}$ , $I_D = 3\text{ A}$ , $R_G = 4.7\text{ }\Omega$ , $V_{GS} = 10\text{ V}$		12		
$t_r$	Rise time			12		
$t_{d(off)}$	Turn-off delay time	(see Figure 16. Test circuit for resistive load switching times and Figure 21. Switching time waveform)	-	37	-	$\text{ns}$
$t_f$	Fall time			19		

**Table 6. Source-drain diode**

Symbol	Parameter	Test conditions	Min.	Typ.	Max.	Unit	
$I_{SD}$	Source-drain current		-		6	A	
$I_{SDM}^{(1)}$	Source-drain current (pulsed)				24		
$V_{SD}^{(2)}$	Forward on voltage	$I_{SD} = 6\text{ A}$ , $V_{GS} = 0\text{ V}$	-		1.5	V	
$t_{rr}$	Reverse recovery time	$I_{SD} = 6\text{ A}$ , $di/dt = 100\text{ A}/\mu\text{s}$ , $V_{DD} = 60\text{ V}$ (see Figure 18. Test circuit for inductive load switching and diode recovery times)	-	110		ns	
$Q_{rr}$	Reverse recovery charge			0.44			μC
$I_{RRM}$	Reverse recovery current			8			
$t_{rr}$	Reverse recovery time	$I_{SD} = 6\text{ A}$ , $di/dt = 100\text{ A}/\mu\text{s}$ , $V_{DD} = 60\text{ V}$ , $T_j = 150\text{ °C}$ (see Figure 18. Test circuit for inductive load switching and diode recovery times)	-	140		ns	
$Q_{rr}$	Reverse recovery charge			0.68			μC
$I_{RRM}$	Reverse recovery current			10			

1. Pulse width limited by safe operating area.
2. Pulsed: pulse duration = 300 μs, duty cycle 1.5%.

**Table 7. Gate-source Zener diode**

Symbol	Parameter	Test conditions	Min.	Typ.	Max.	Unit
$V_{(BR)GSO}$	Gate-source breakdown voltage	$I_{GS} = \pm 1\text{ mA}$ , $I_D = 0\text{ A}$	30	-	-	V

The built-in back-to-back Zener diodes are specifically designed to enhance the ESD performance of the device. The Zener voltage facilitates efficient and cost-effective device integrity protection, thus eliminating the need for additional external componentry.

## 2.1 Electrical characteristics (curves)

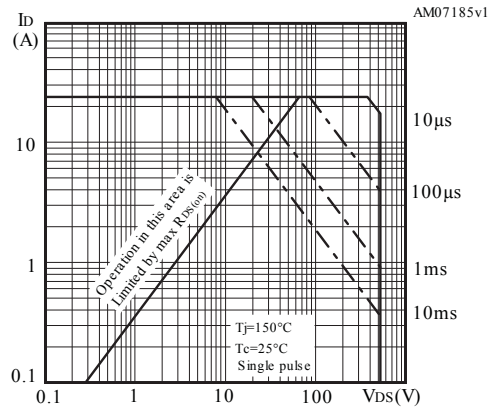
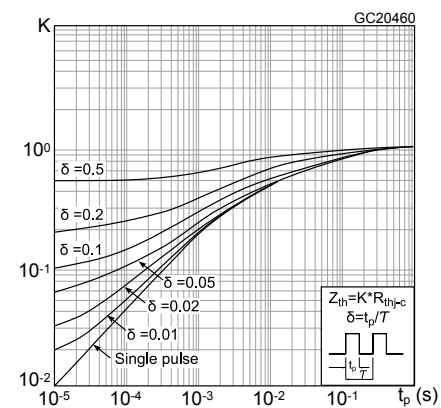
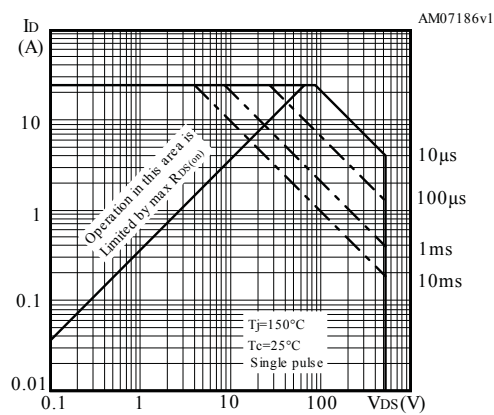
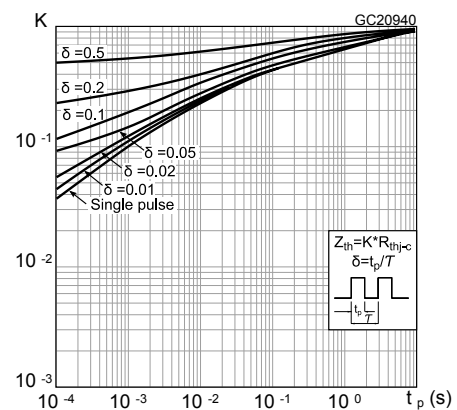
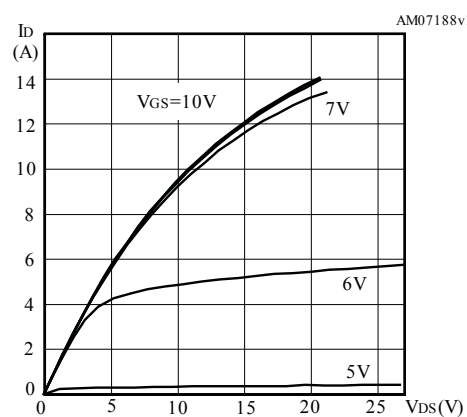
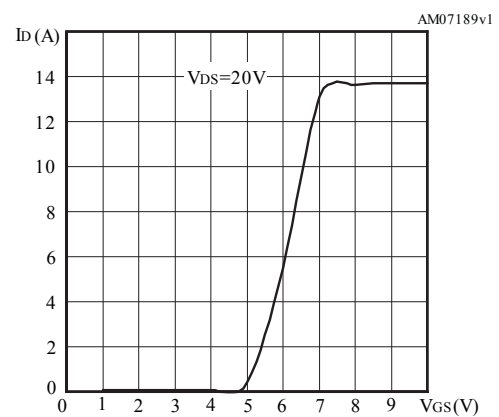
**Figure 1. Safe operating area for DPAK**

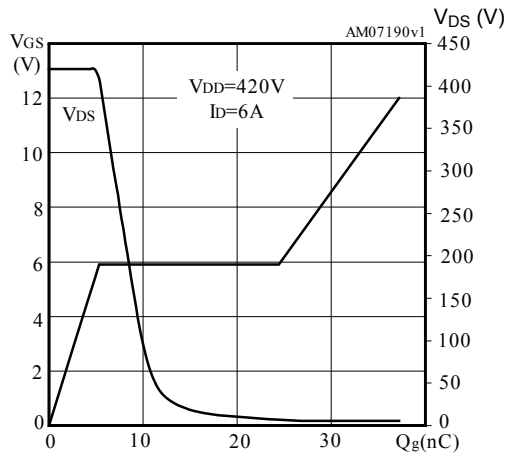
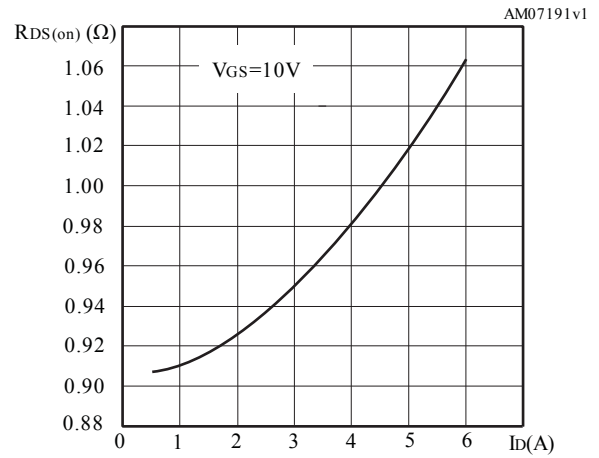
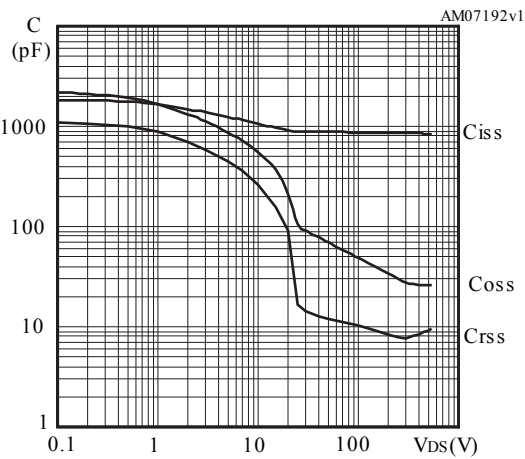
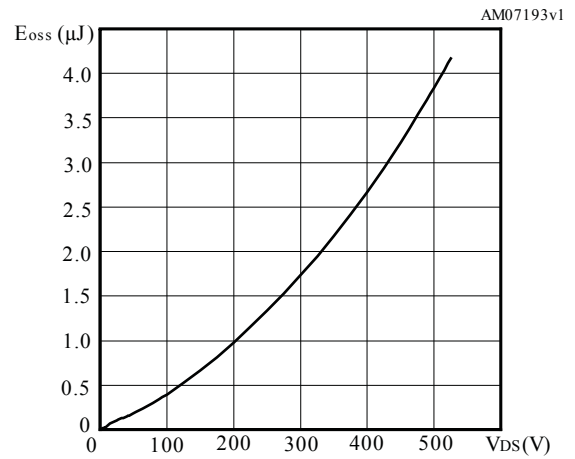
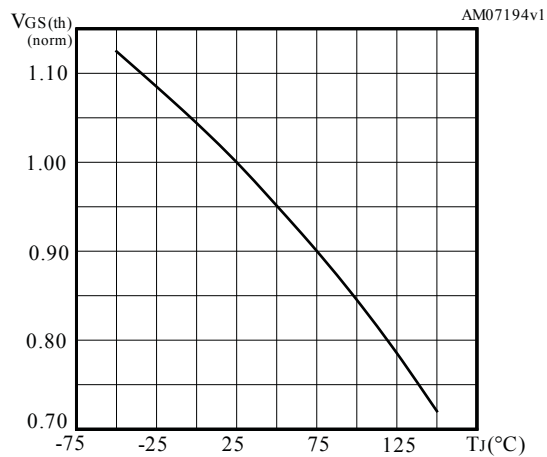
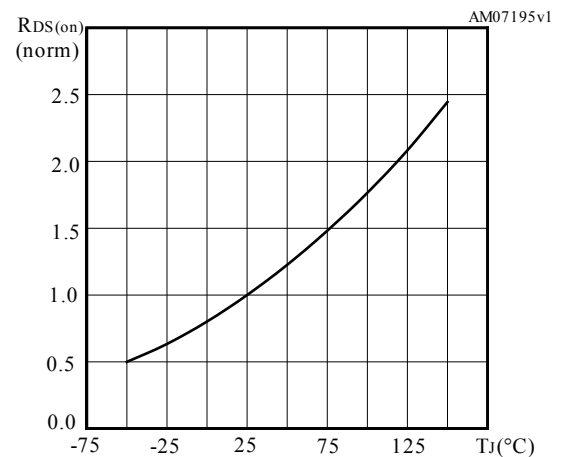
**Figure 2. Thermal impedance for DPAK**

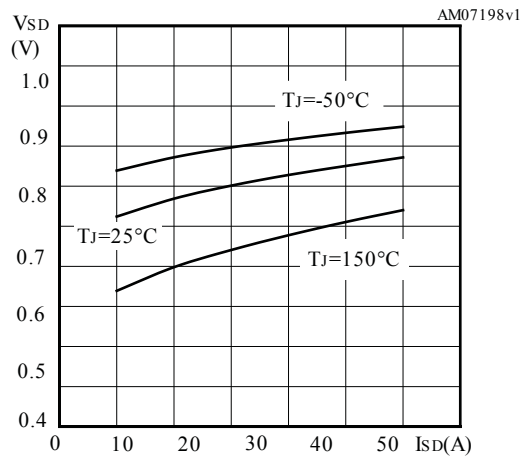
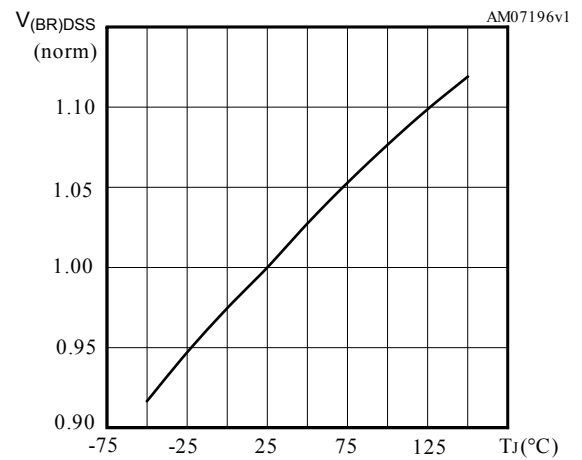
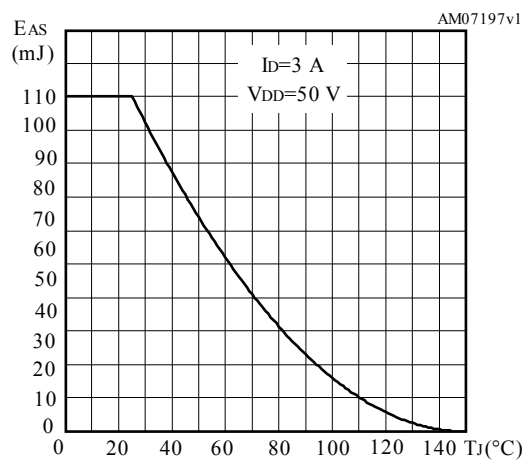
**Figure 3. Safe operating area for TO-220FP**

**Figure 4. Thermal impedance for TO-220FP**

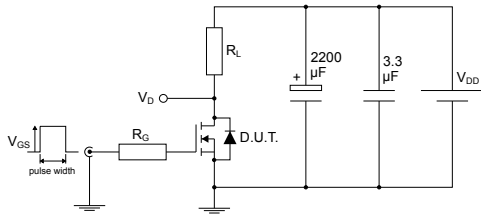
**Figure 5. Output characteristics**

**Figure 6. Transfer characteristics**

**Figure 7. Gate charge vs gate-source voltage**

**Figure 8. Static drain-source on-resistance**

**Figure 9. Capacitance variations**

**Figure 10. Output capacitance stored energy**

**Figure 11. Normalized gate threshold voltage vs temperature**

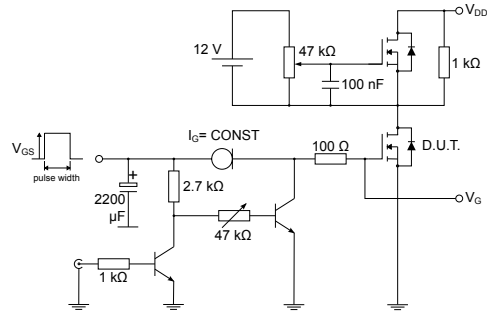
**Figure 12. Normalized on-resistance vs temperature**

**Figure 13. Source-drain diode forward characteristics**

**Figure 14. Normalized V<sub>(BR)DSS</sub> vs temperature**

**Figure 15. Maximum avalanche energy vs starting T<sub>J</sub>**

### 3 Test circuits

**Figure 16. Test circuit for resistive load switching times**

AM01468v1

**Figure 17. Test circuit for gate charge behavior**

AM01469v1

**Figure 18. Test circuit for inductive load switching and diode recovery times**

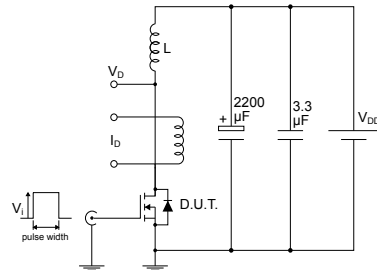

AM01470v1

**Figure 19. Unclamped inductive load test circuit**

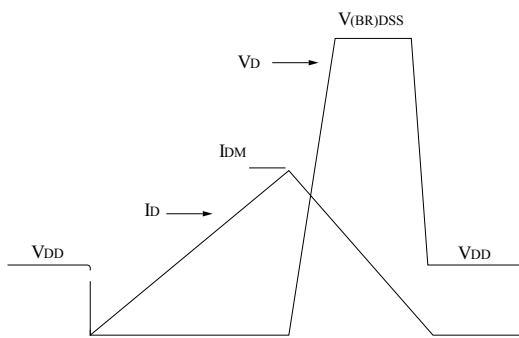
AM01471v1

**Figure 20. Unclamped inductive waveform**

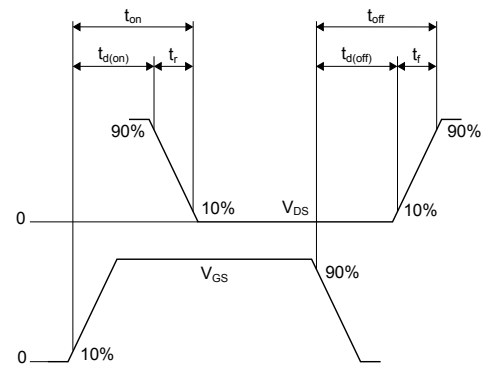
AM01472v1

**Figure 21. Switching time waveform**

AM01473v1

## 4 Package information

---

In order to meet environmental requirements, ST offers these devices in different grades of ECOPACK® packages, depending on their level of environmental compliance. ECOPACK® specifications, grade definitions and product status are available at: [www.st.com](http://www.st.com). ECOPACK® is an ST trademark.

#### 4.1 DPAK (TO-252) type A2 package information

Figure 22. DPAK (TO-252) type A2 package outline

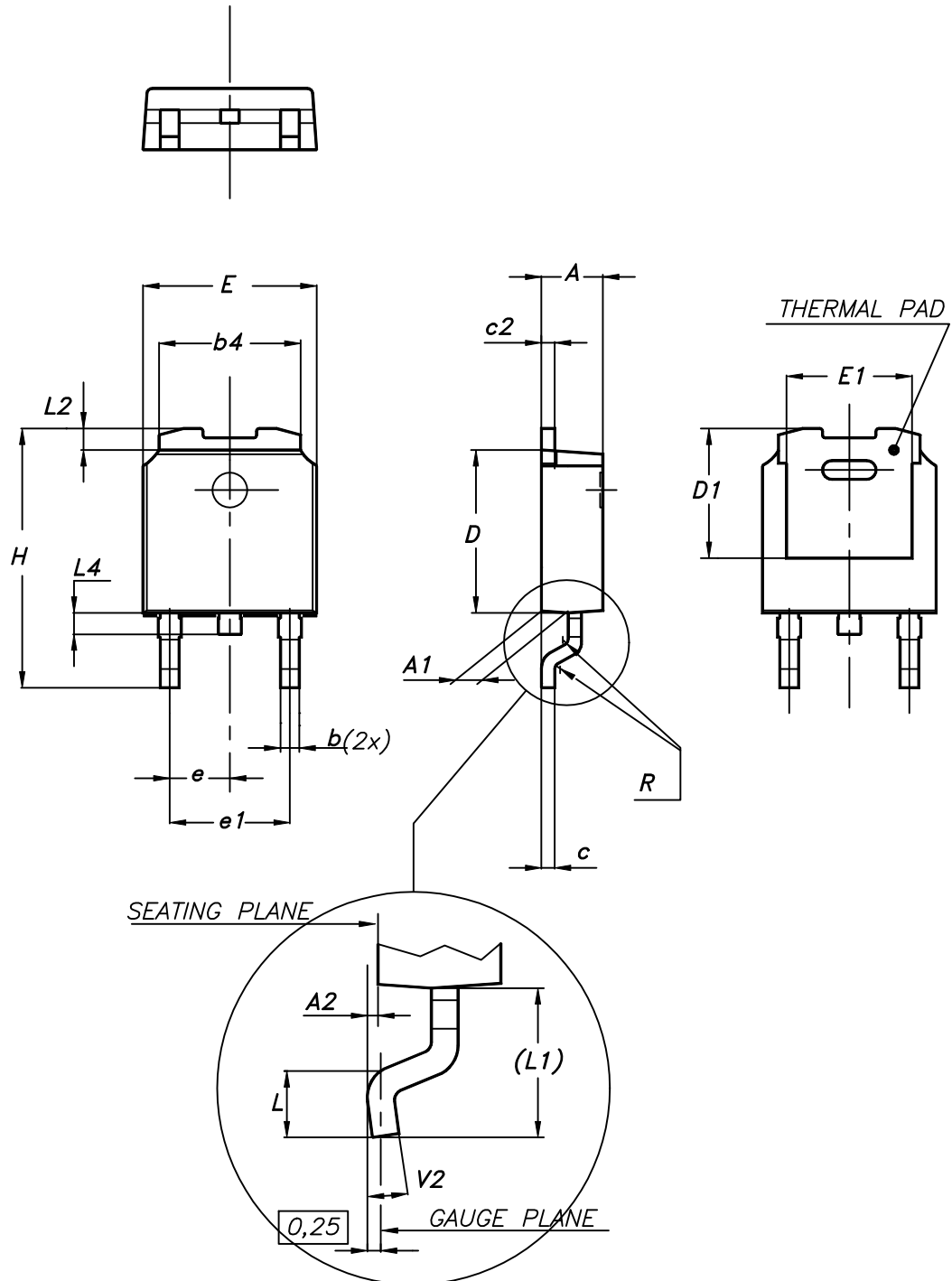

0068772\_type-A2\_rev25

**Table 8. DPAK (TO-252) type A2 mechanical data**

Dim.	mm		
	Min.	Typ.	Max.
A	2.20		2.40
A1	0.90		1.10
A2	0.03		0.23
b	0.64		0.90
b4	5.20		5.40
c	0.45		0.60
c2	0.48		0.60
D	6.00		6.20
D1	4.95	5.10	5.25
E	6.40		6.60
E1	5.10	5.20	5.30
e	2.159	2.286	2.413
e1	4.445	4.572	4.699
H	9.35		10.10
L	1.00		1.50
L1	2.60	2.80	3.00
L2	0.65	0.80	0.95
L4	0.60		1.00
R		0.20	
V2	0°		8°

Figure 23. DPAK (TO-252) recommended footprint (dimensions are in mm)

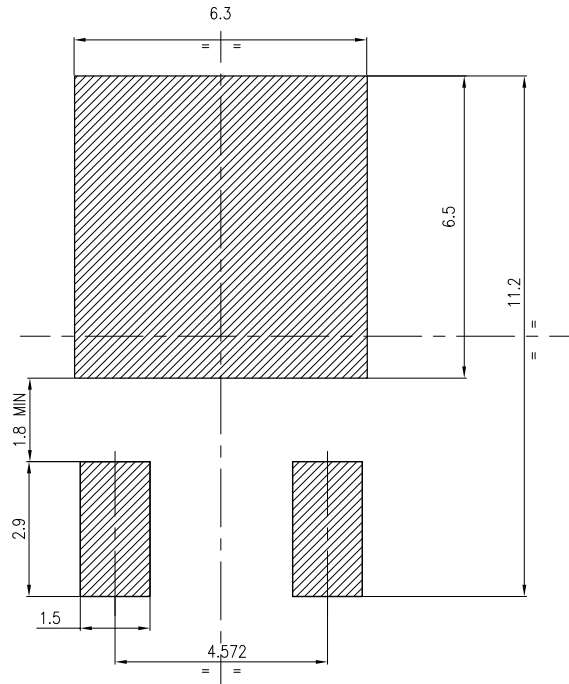

FP\_0068772\_25

## 4.2 DPAK (TO-252) packing information

Figure 24. DPAK (TO-252) tape outline

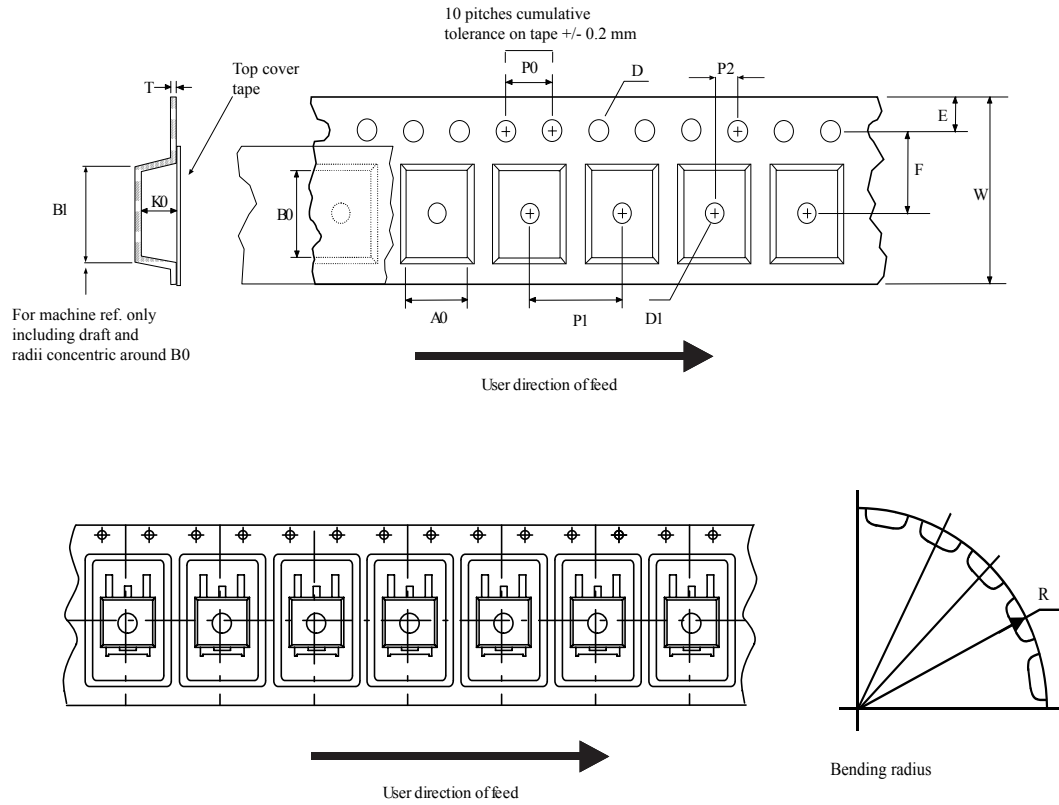

AM08852v1

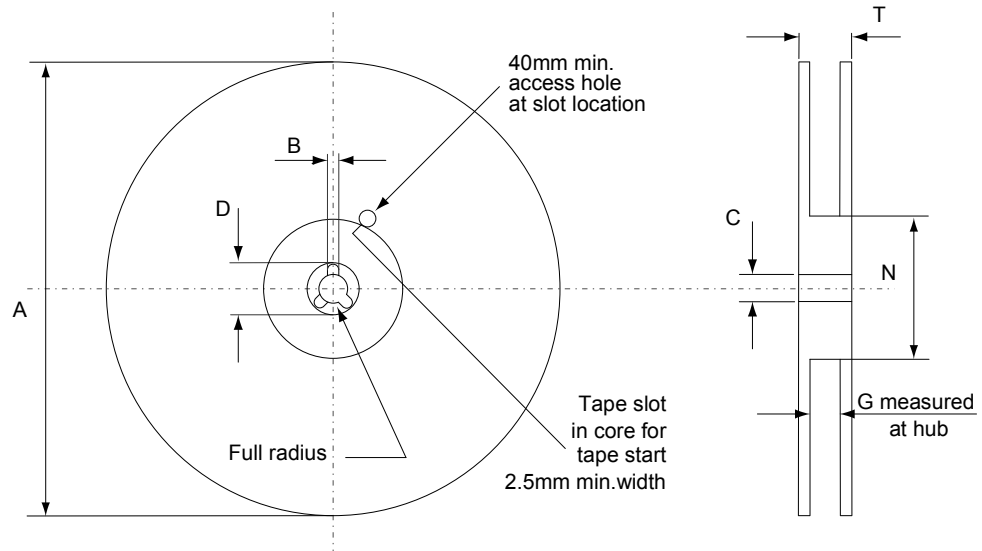
**Figure 25. DPAK (TO-252) reel outline**

AM06038v1

**Table 9. DPAK (TO-252) tape and reel mechanical data**

Tape			Reel		
Dim.	mm		Dim.	mm	
	Min.	Max.		Min.	Max.
A0	6.8	7	A		330
B0	10.4	10.6	B	1.5	
B1		12.1	C	12.8	13.2
D	1.5	1.6	D	20.2	
D1	1.5		G	16.4	18.4
E	1.65	1.85	N	50	
F	7.4	7.6	T		22.4
K0	2.55	2.75			
P0	3.9	4.1	Base qty.		2500
P1	7.9	8.1	Bulk qty.		2500
P2	1.9	2.1			
R	40				
T	0.25	0.35			
W	15.7	16.3			

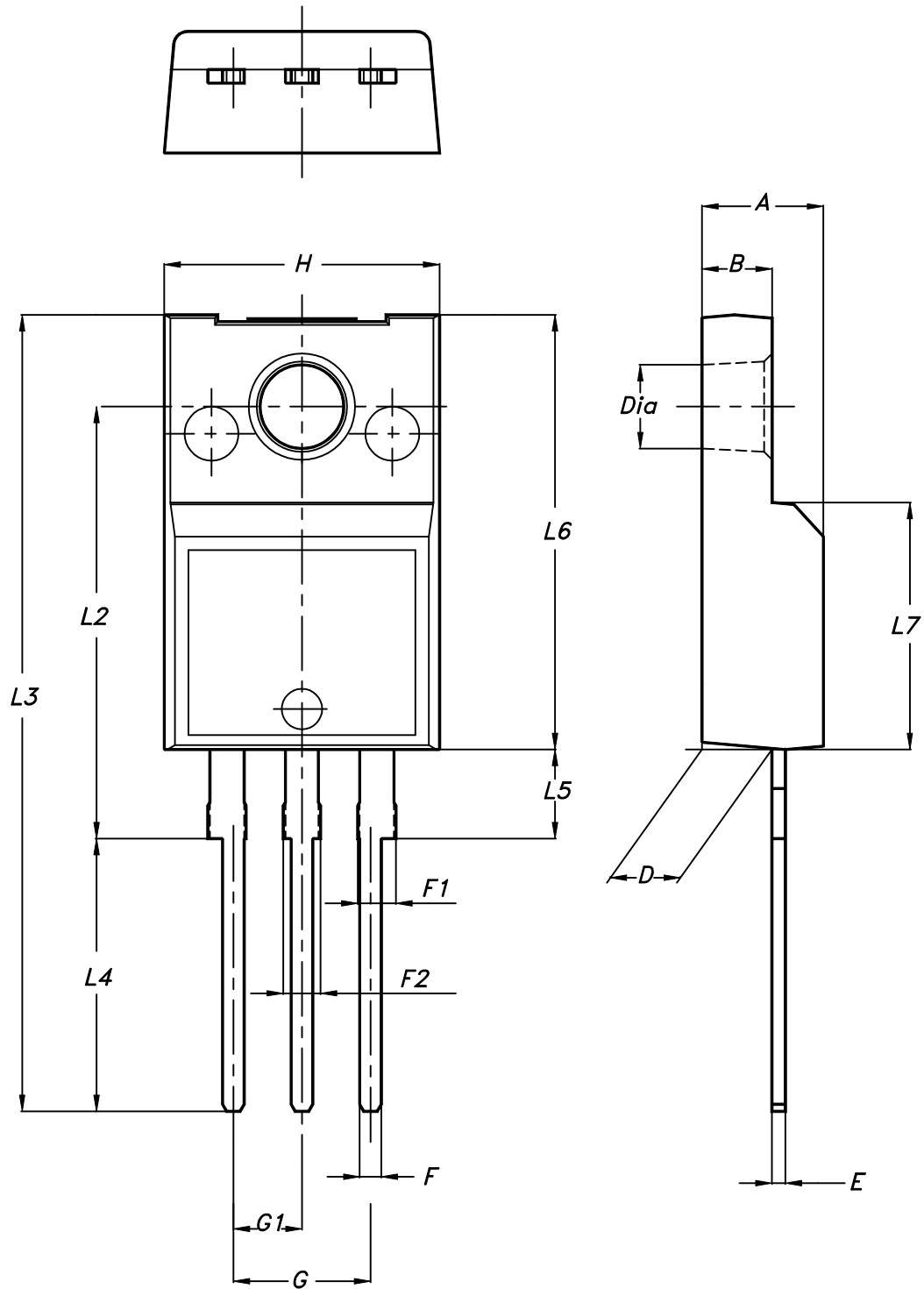
**4.3 TO-220FP package information**
**Figure 26. TO-220FP package outline**

7012510\_Rev\_12\_B

**Table 10. TO-220FP package mechanical data**

Dim.	mm		
	Min.	Typ.	Max.
A	4.4		4.6
B	2.5		2.7
D	2.5		2.75
E	0.45		0.7
F	0.75		1
F1	1.15		1.70
F2	1.15		1.70
G	4.95		5.2
G1	2.4		2.7
H	10		10.4
L2		16	
L3	28.6		30.6
L4	9.8		10.6
L5	2.9		3.6
L6	15.9		16.4
L7	9		9.3
Dia	3		3.2

## Revision history

**Table 11. Document revision history**

Date	Version	Changes
09-Oct-2009	1	First release
20-Oct-2010	2	Document status promoted from preliminary data to datasheet
01-Oct-2018	3	The part number STP7N52DK3 has been moved to a separate datasheet and the document has been updated accordingly. Updated <a href="#">Section 4 Package information</a> . Minor text changes

## Contents

<b>1</b>	<b>Electrical ratings</b> .....	<b>2</b>
<b>2</b>	<b>Electrical characteristics</b> .....	<b>3</b>
<b>2.1</b>	<b>Electrical characteristics (curves)</b> .....	<b>5</b>
<b>3</b>	<b>Test circuits</b> .....	<b>8</b>
<b>4</b>	<b>Package information</b> .....	<b>9</b>
<b>4.1</b>	<b>DPAK (TO-252) type A2 package information</b> .....	<b>9</b>
<b>4.2</b>	<b>DPAK (TO-252) packing information</b> .....	<b>12</b>
<b>4.3</b>	<b>TO-220FP package information</b> .....	<b>14</b>
	<b>Revision history</b> .....	<b>17</b>

**IMPORTANT NOTICE – PLEASE READ CAREFULLY**

STMicroelectronics NV and its subsidiaries (“ST”) reserve the right to make changes, corrections, enhancements, modifications, and improvements to ST products and/or to this document at any time without notice. Purchasers should obtain the latest relevant information on ST products before placing orders. ST products are sold pursuant to ST’s terms and conditions of sale in place at the time of order acknowledgement.

Purchasers are solely responsible for the choice, selection, and use of ST products and ST assumes no liability for application assistance or the design of Purchasers’ products.

No license, express or implied, to any intellectual property right is granted by ST herein.

Resale of ST products with provisions different from the information set forth herein shall void any warranty granted by ST for such product.

ST and the ST logo are trademarks of ST. All other product or service names are the property of their respective owners.

Information in this document supersedes and replaces information previously supplied in any prior versions of this document.

© 2018 STMicroelectronics – All rights reserved

## Looking for pricing, stock, or lifecycle information?

Click below to explore more details on WIN SOURCE:

- ⊖ [View STF7N52DK3](#) on WIN SOURCE
- ⊖ [STMicroelectronics](#) Information

## Optimize Your Supply Chain with WIN SOURCE Solutions

- ✓ Global Sourcing Solution
- ✓ Obsolete Management
- ✓ Cost Control Management
- ✓ Shortage Management
- ✓ Alternative Solution
- ✓ Excess Inventory Management