



**THE DATASHEET OF
TPS7A6050QKVURQ1**



TPS7A6x-Q1 300-mA, 40-V Low-Dropout Regulator With 25- μ A Quiescent Current

1 Features

- Qualified for Automotive Applications
- AEC-Q100 Test Guidance With the Following Results:
 - Device Temperature Grade 1: -40°C to 125°C Ambient Operating Temperature
 - Device HBM ESD Classification Level H3A
 - Device CDM ESD Classification Level C6
- Low Dropout Voltage
 - 300 mV at $I_{\text{OUT}} = 150$ mA
- 11-V to 40-V Wide Input Voltage Range With up to 45-V Transients
- 300-mA Maximum Output Current
- Ultralow Quiescent Current
 - $I_{\text{QUIESCENT}} = 25$ μA (Typical) at Light Loads
 - $I_{\text{SLEEP}} < 2$ μA When ENABLE = Low
- 3.3-V and 5-V Fixed Output Voltage
- Low-ESR Ceramic Output Stability Capacitor
- Integrated Power-On Reset
 - Programmable Delay
 - Open-Drain Reset Output
- Integrated Fault Protection
 - Short-Circuit and Overcurrent Protection
 - Thermal Shutdown
- Low-Input-Voltage Tracking
- Thermally Enhanced Power Package
 - 5-pin TO-263 (KTT, D2PAK)
 - 5-pin TO-252 (KVU, DPAK)

2 Applications

- Infotainment Systems With Sleep Mode
- Body Control Modules
- Always-On Battery Applications
 - Gateway Applications
 - Remote Keyless Entry Systems
 - Immobilizers

3 Description

The TPS7A60-Q1 and TPS7A61-Q1 comprise a family of low-dropout linear voltage regulators designed for low power consumption and quiescent current less than 25 μA in light-load applications. These devices feature integrated overcurrent protection and are designed to achieve stable operation even with low-ESR ceramic capacitors. Power-on-reset delay is implemented during device start-up to indicate that the output voltage is stable and in regulation. The power-on-reset delay is fixed (250 μs typical), and can also be programmed by an external capacitor. A low-voltage tracking feature allows for a smaller input capacitor and can possibly eliminate the need of using a boost converter during cold-crank conditions. Because of these features, these devices are well-suited in power supplies for various automotive applications.

Device Information⁽¹⁾

PART NUMBER	PACKAGE	BODY SIZE (NOM)
TPS7A6033-Q1	TO-263 (5)	10.16 mm \times 9.15 mm
	TO-252 (5)	6.10 mm \times 6.60 mm
TPS7A6050-Q1	TO-263 (5)	10.16 mm \times 9.15 mm
	TO-252 (5)	6.10 mm \times 6.60 mm
TPS7A6133-Q1	TO-252 (5)	6.10 mm \times 6.60 mm
TPS7A6150-Q1	TO-252 (5)	6.10 mm \times 6.60 mm

(1) For all available packages, see the orderable addendum at the end of the data sheet.

Programmable Reset Delay Option

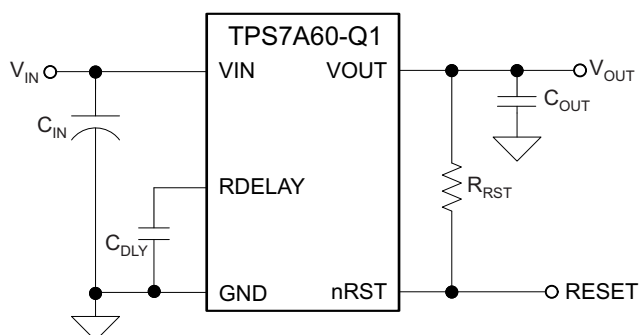

Enable Option

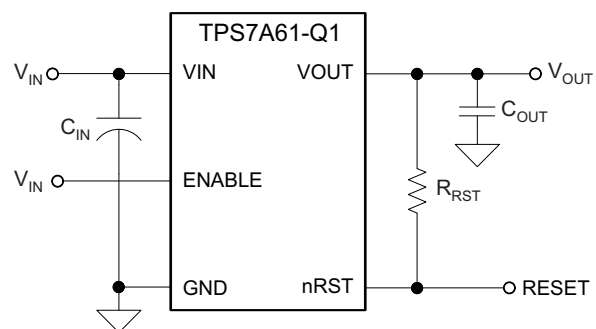

Table of Contents

1 Features	1	8.3 Feature Description	12
2 Applications	1	8.4 Device Functional Modes	16
3 Description	1	9 Application and Implementation	17
4 Revision History	2	9.1 Application Information	17
5 Device Comparison Table	3	9.2 Typical Applications	17
6 Pin Configuration and Functions	4	10 Power Supply Recommendations	21
7 Specifications	5	11 Layout	21
7.1 Absolute Maximum Ratings	5	11.1 Layout Guidelines	21
7.2 ESD Ratings	5	11.2 Layout Examples	24
7.3 Recommended Operating Conditions	5	12 Device and Documentation Support	26
7.4 Thermal Information	5	12.1 Related Links	26
7.5 Electrical Characteristics	6	12.2 Receiving Notification of Documentation Updates	26
7.6 Switching Characteristics	7	12.3 Community Resources	26
7.7 Typical Characteristics	8	12.4 Trademarks	26
8 Detailed Description	11	12.5 Electrostatic Discharge Caution	26
8.1 Overview	11	12.6 Glossary	26
8.2 Functional Block Diagrams	11	13 Mechanical, Packaging, and Orderable Information	26

4 Revision History

NOTE: Page numbers for previous revisions may differ from page numbers in the current version.

Changes from Revision H (March 2016) to Revision I	Page
• Changed device names from TPS7A6033-Q1, TPS7A6050-Q1, TPS7A6133-Q1, and TPS7A6150-Q1 to TPS7A60-Q1 and TPS7A61-Q1	1
• Changed 4 V to 11 V in fourth <i>Features</i> bullet	1
• Changed V_{IN} minimum specification from 4 V to 11 V in <i>Recommended Operating Conditions</i> table	5
• Changed V_{IN} and V_{ENABLE} parameters to be separate rows, changed V_{ENABLE} description to <i>Enable pin voltage</i>	5
• Changed V_{IN} parameter: condensed test conditions to one row and changed minimum specification from 5.3 V to 11 V ...	6
• Changed 4 V (3.3-V version) or 5.3 V (5-V version) to 11 V in <i>Regulation Mode</i> section	16
• Changed <i>Input voltage range</i> parameter example value in <i>TPS7A60-Q1 Design Parameters</i> table	17
• Changed <i>Input voltage range</i> parameter example value in <i>TPS7A61-Q1 Design Parameters</i> table	19

Changes from Revision G (April 2012) to Revision H	Page
• Added new bullets to top of <i>Features</i> list	1
• Appended "-Q1" to the part number in numerous locations throughout the data sheet	1
• Added <i>ESD Rating</i> table, <i>Switching Characteristics</i> table <i>Feature Description</i> section, <i>Device Functional Modes</i> , <i>Application and Implementation</i> section, <i>Power Supply Recommendations</i> section, <i>Layout</i> section, <i>Device and Documentation Support</i> section, and <i>Mechanical, Packaging, and Orderable Information</i> section	1
• Added MIN values for V_{IN} , R_{DELAY} , and V_{OUT} in <i>Absolute Maximum Ratings</i> table	5
• Deleted two graphs from the <i>Typical Characteristics</i> section	8
• Updated <i>Typical Application Schematic</i> for the TPS7A61xx-Q1 Device image.	19

5 Device Comparison Table

PART NUMBER	OUTPUT VOLTAGE	ENABLE	RESET	PROGRAMMABLE RESET DELAY
TPS7A6033-Q1	3.3 V	No	Yes	Yes
		No	Yes	Yes
TPS7A6050-Q1	5 V	No	Yes	Yes
		No	Yes	Yes
TPS7A6133-Q1	3.3 V	Yes	Yes	No
TPS7A6150-Q1	5 V	Yes	Yes	No

6 Pin Configuration and Functions

KTT Package
5-Pin TO-263 With Exposed Thermal Pad
Top View

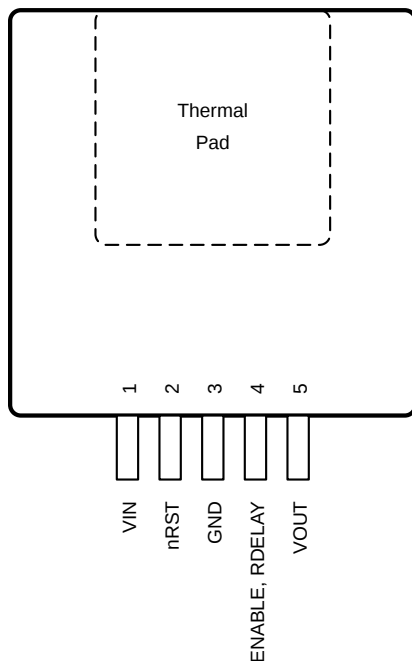

KVU Package
5-Pin TO-252 With Exposed Thermal Pad
Top View

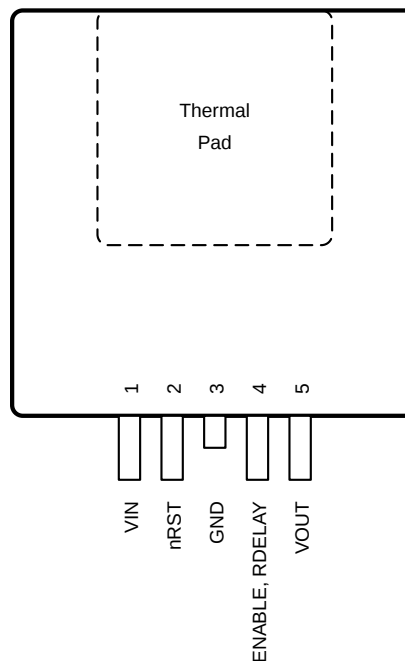

Pin Functions

PIN		TYPE	DESCRIPTION
NAME	NO.		
ENABLE	4	I	Enable pin (for TPS7A61-Q1 only): This is a high-voltage-tolerant input pin with an internal pulldown. A high input to this pin activates the device and turns the regulator ON. This input can be connected to the VIN pin for self-bias applications. If this pin is not connected, the device stays disabled.
GND	3	I/O	Ground pin: This is the signal-ground pin of the IC.
nRST	2	O	Reset pin: This is an output pin with an external pullup resistor connected to the VOUT pin.
RDELAY	4	O	Reset delay timer pin (for TPS7A60-Q1 only): This pin is used to program the reset delay timer using an external capacitor (C_{DLY}) to ground.
VIN	1	I	Input voltage pin: The unregulated input voltage is supplied to this pin. A bypass capacitor is connected between the VIN pin and the GND pin to dampen input line transients.
VOUT	5	O	Regulated output-voltage pin: This is a regulated voltage output ($V_{OUT} = 3.3\text{ V}$ or 5 V , as applicable) pin with a limitation on maximum output current. In order to achieve stable operation and prevent oscillation, an external output capacitor (C_{OUT}) with low ESR is connected between this pin and the GND pin.

7 Specifications

7.1 Absolute Maximum Ratings

over operating free-air temperature range (unless otherwise noted)⁽¹⁾

		MIN	MAX	UNIT
Unregulated inputs ⁽²⁾	V _{IN} , ENABLE	-0.3	45	V
Regulated output	V _{OUT}	-0.3	7	V
Open-drain reset output	nRST	-0.3	7	V
Output to charge an external capacitor	RDELAY	-0.3	7	V
Operating ambient temperature, T _J		-40	150	°C
Storage temperature, T _{stg}		-65	150	°C

- (1) Stresses beyond those listed under *Absolute Maximum Ratings* may cause permanent damage to the device. These are stress ratings only, which do not imply functional operation of the device at these or any other conditions beyond those indicated under *Recommended Operating Conditions*. Exposure to absolute-maximum-rated conditions for extended periods may affect device reliability.
- (2) Absolute maximum voltage for duration less than 480 ms

7.2 ESD Ratings

		VALUE	UNIT
TPS7A60-Q1 and TPS7A61-Q1 Devices in KVV Package			
V _(ESD)	Electrostatic discharge	Human-body model (HBM), per AEC Q100-002 ⁽¹⁾	±4000
		Charged-device model (CDM), per AEC Q100-011	±1000
TPS7A60-Q1 Device in KTT Package			
V _(ESD)	Electrostatic discharge	Human-body model (HBM), per AEC Q100-002 ⁽¹⁾	±4000
		Charged-device model (CDM), per AEC Q100-011	±1500

- (1) AEC Q100-002 indicates that HBM stressing shall be in accordance with the ANSI/ESDA/JEDEC JS-001 specification.

7.3 Recommended Operating Conditions

over operating ambient temperature range (unless otherwise noted)

		MIN	MAX	UNIT
V _{IN}	Unregulated input voltage	11	40	V
V _{ENABLE}	Enable pin voltage ⁽¹⁾	4	40	V
V _{nRST} , V _{RDELAY}	Low-voltage output range ⁽²⁾	0	5.25	V
I _{OUT}	Output current	0	300	mA
T _A	Operating ambient temperature	-40	150	°C

- (1) Applicable for the TPS7A61-Q1 only.
- (2) Applicable for the TPS7A60-Q1 only.

7.4 Thermal Information

THERMAL METRIC ⁽¹⁾⁽²⁾		TPS7A60-Q1, TPS7A61-Q1	TPS7A60-Q1	UNIT
		KVV (TO-252)	KTT (TO-263)	
		5 PINS	5 PINS	
R _{θJA}	Junction-to-ambient thermal resistance	26.9	24.7	°C/W
R _{θJC(top)}	Junction-to-case (top) thermal resistance	32.2	38.9	°C/W
R _{θJB}	Junction-to-board thermal resistance	6.5	7.4	°C/W
ψ _{JT}	Junction-to-top characterization parameter	2.5	3.8	°C/W
ψ _{JB}	Junction-to-board characterization parameter	6.5	7.4	°C/W
R _{θJC(bot)}	Junction-to-case (bottom) thermal resistance	2.8	1.5	°C/W

- (1) The thermal data is based on JEDEC standard high K profile JESD 51-5. The copper pad is soldered to the thermal land pattern. The correct attachment procedure must be incorporated.
- (2) For more information about traditional and new thermal metrics, see the *Semiconductor and IC Package Thermal Metrics* application report.

7.5 Electrical Characteristics

 $V_{IN} = 14\text{ V}$, $T_J = -40^\circ\text{C}$ to 150°C (unless otherwise noted)

PARAMETER		TEST CONDITIONS	MIN	TYP	MAX	UNIT
INPUT VOLTAGE (VIN PIN)						
V_{IN}	Input voltage	Fixed 5-V or 3.3-V output, $I_{OUT} = 1\text{ mA}$	11		40	V
$I_{QUIESCENT}$	Quiescent current	$V_{IN} = 8.2\text{ V to }18\text{ V}$, $V_{ENABLE}^{(1)} = 5\text{ V}$, $I_{OUT} = 0.01\text{ mA to }0.75\text{ mA}$		25	40	μA
$I_{SLEEP}^{(1)}$	Sleep or shutdown current	$V_{IN} = 8.2\text{ V to }18\text{ V}$, $V_{ENABLE}^{(1)} < 0.8\text{ V}$, $I_{OUT} = 0\text{ mA (no load)}$, $T_A = 125^\circ\text{C}$			3	μA
$V_{IN-UVLO}$	Undervoltage lockout voltage	Ramp V_{IN} down until output is turned OFF		3.16		V
$V_{IN(POWERUP)}$	Power-up voltage	Ramp V_{IN} up until output is turned ON		3.45		V
ENABLE INPUT (ENABLE PIN)						
$V_{IL}^{(1)}$	Logic input low level		0		0.8	V
$V_{IH}^{(1)}$	Logic input high level		2.5		40	V
REGULATED OUTPUT VOLTAGE (VOUT PIN)						
V_{OUT}	Regulated output voltage	Fixed V_{OUT} value (3.3 V or 5 V as applicable), $I_{OUT} = 10\text{ mA to }300\text{ mA}$, $V_{IN} = V_{OUT} + 1\text{ V to }16\text{ V}$	-2%		2%	
$\Delta V_{LINE-REG}$	Line regulation	$V_{IN} = 6\text{ V to }28\text{ V}$, $I_{OUT} = 10\text{ mA}$, $V_{OUT} = 5\text{ V}$			15	mV
		$V_{IN} = 6\text{ V to }28\text{ V}$, $I_{OUT} = 10\text{ mA}$, $V_{OUT} = 3.3\text{ V}$			20	mV
$\Delta V_{LOAD-REG}$	Load regulation	$I_{OUT} = 10\text{ mA to }300\text{ mA}$, $V_{IN} = 14\text{ V}$, $V_{OUT} = 5\text{ V}$			25	mV
		$I_{OUT} = 10\text{ mA to }300\text{ mA}$, $V_{IN} = 14\text{ V}$, $V_{OUT} = 3.3\text{ V}$			35	mV
$V_{DROPOUT}^{(2)}$	Dropout voltage ($V_{IN} - V_{OUT}$)	$I_{OUT} = 250\text{ mA}$			500	mV
		$I_{OUT} = 150\text{ mA}$			300	mV
R_{SW}	Switch resistance	V_{IN} to V_{OUT} resistance			2	Ω
I_{CL}	Output current limit	$V_{OUT} = 0\text{ V}$ (V_{OUT} pin is shorted to ground)	350		1000	mA
PSRR	Power supply ripple rejection	$V_{IN-RIPPLE} = 0.5\text{ Vpp}$, $I_{OUT} = 300\text{ mA}$, frequency = 100 Hz, $V_{OUT} = 5\text{ V}$ and $V_{OUT} = 3.3\text{ V}$		60		dB
		$V_{IN-RIPPLE} = 0.5\text{ Vpp}$, $I_{OUT} = 300\text{ mA}$, frequency = 150 kHz, $V_{OUT} = 5\text{ V}$ and $V_{OUT} = 3.3\text{ V}$		30		
RESET (nRST PIN)						
V_{OL}	Reset pulled low	$I_{OL} = 5\text{ mA}$			0.4	V
I_{OH}	Leakage current	Reset pulled to V_{OUT} through 5-k Ω resistor			1	μA
$V_{TH(POR)}$	Power-on-reset threshold	V_{OUT} power up above internally set tolerance, $V_{OUT} = 5\text{ V}$	4.5	4.65	4.77	V
		V_{OUT} power up above internally set tolerance, $V_{OUT} = 3.3\text{ V}$		3.07		
UVTHRES	Reset threshold	V_{OUT} falling below internally set tolerance, $V_{OUT} = 5\text{ V}$	4.5	4.65	4.77	V
		V_{OUT} falling below internally set tolerance, $V_{OUT} = 3.3\text{ V}$		3.07		

(1) Applicable for the TPS7A61-Q1 only.

 (2) This test is done with V_{OUT} in regulation and $V_{IN} - V_{OUT}$ parameter is measured when V_{OUT} (3.3 V or 5 V) drops by 100 mV at specified loads.

Electrical Characteristics (continued)

 $V_{IN} = 14\text{ V}$, $T_J = -40^\circ\text{C}$ to 150°C (unless otherwise noted)

PARAMETER		TEST CONDITIONS	MIN	TYP	MAX	UNIT
RESET DELAY (RDELAY PIN)						
$V_{TH(RDELAY)}^{(3)}$	Threshold to release nRST high	Voltage at RDELAY pin is ramped up.		3	3.3	V
$I_{DLY}^{(3)}$	Delay capacitor charging current		0.75	1	1.25	μA
$I_{OL}^{(3)}$	Delay capacitor discharging current	Voltage at RDELAY pin = 1 V	5			mA
OPERATING TEMPERATURE RANGE						
T_J	Operating junction temperature		-40		150	$^\circ\text{C}$
$T_{SHUTDOWN}$	Thermal shutdown trip point			165		$^\circ\text{C}$
T_{HYST}	Thermal shutdown hysteresis			10		$^\circ\text{C}$

(3) Applicable for the TPS7A60-Q1 only.

7.6 Switching Characteristics

over operating free-air temperature range (unless otherwise noted)

PARAMETER		TEST CONDITIONS	MIN	TYP	MAX	UNIT
RESET (nRST PIN)						
t_{POR}	Power-on-reset delay	$C_{DLY} = 100\text{ pF}$		300		μs
		$C_{DLY} = 100\text{ nF}$		300		ms
$t_{POR-PRESET}$	Internally preset power-on-reset delay	C_{DLY} not connected in TPS7A60xx or not available in TPS7A61xx, $V_{OUT} = 5\text{ V}$ and $V_{OUT} = 3.3\text{ V}$		250		μs
$t_{DEGLITCH}$	Reset deglitch time			5.5		μs

7.7 Typical Characteristics

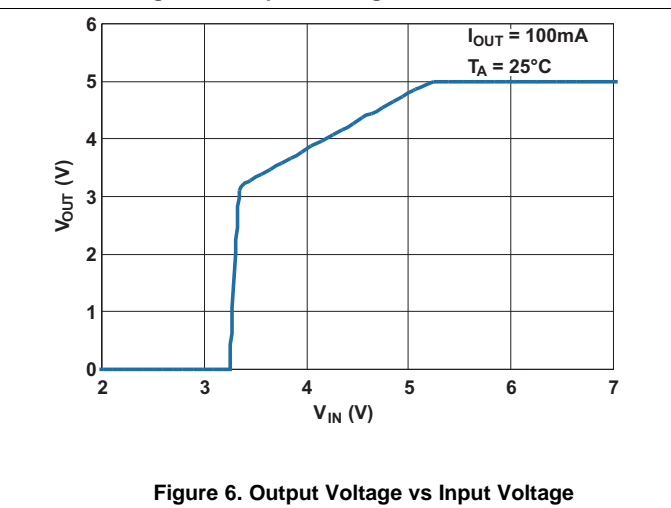
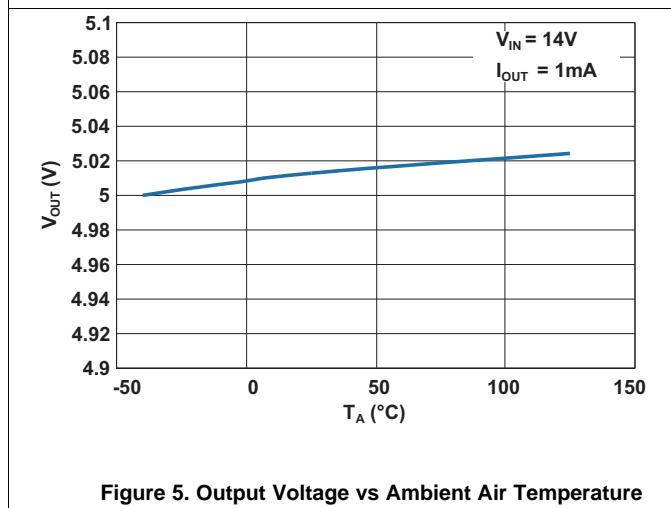
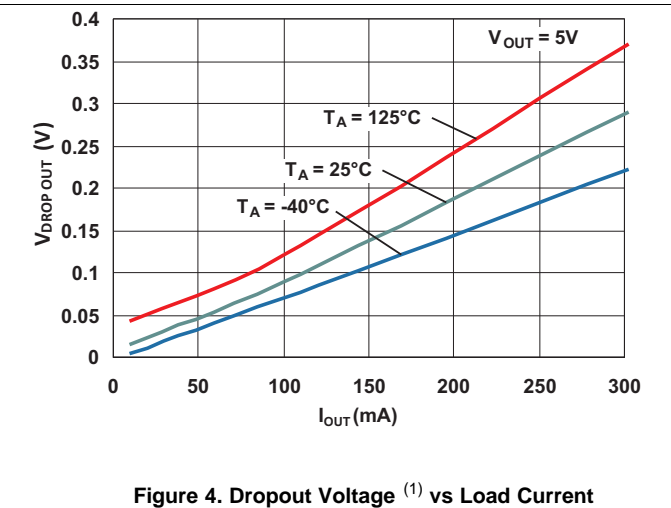
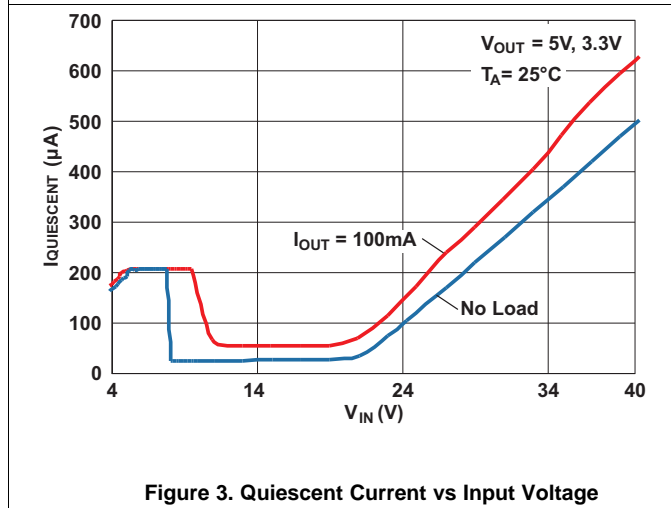
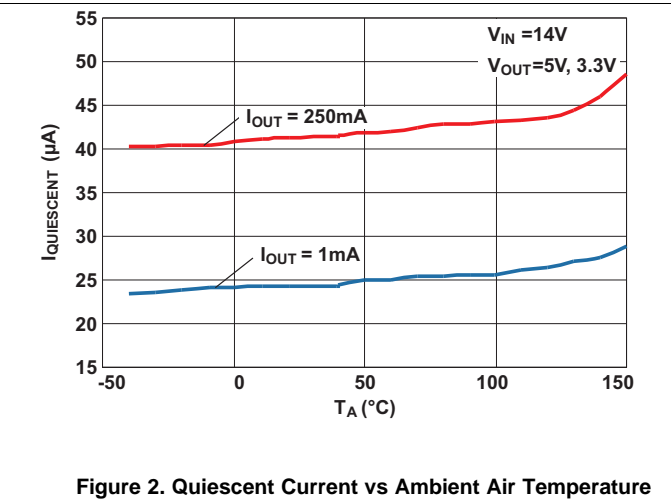
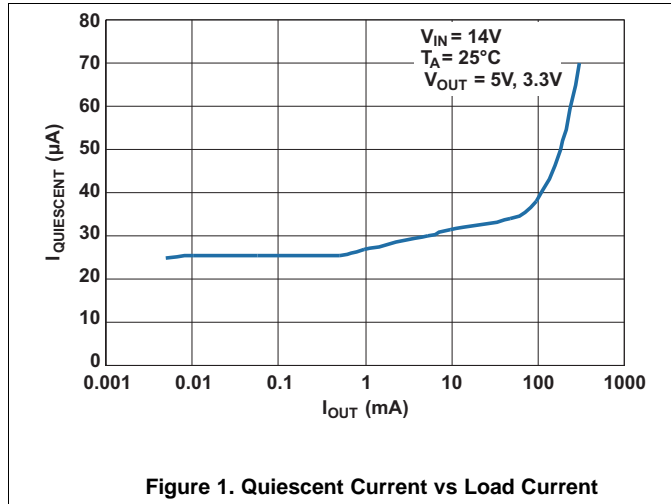

(1) Dropout voltage is measured when the output voltage drops by 100 mV from the regulated output voltage level. (For example, dropout voltage for the TPS7A6050-Q1 is measured when the output voltage drops down to 4.9 V from 5 V.)

Typical Characteristics (continued)

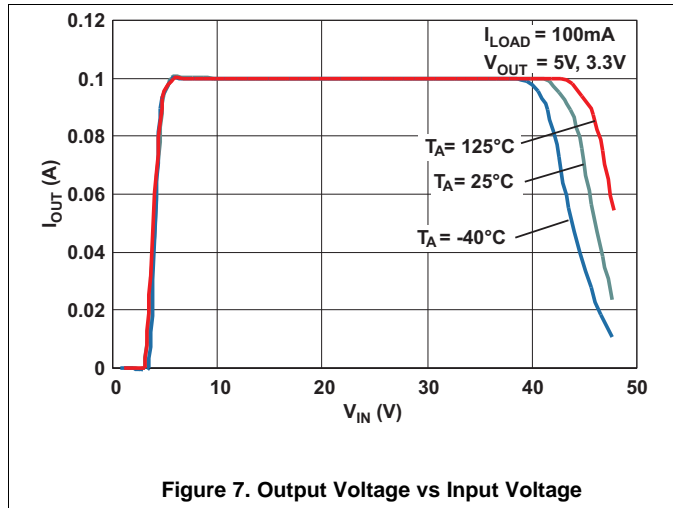

Figure 7. Output Voltage vs Input Voltage

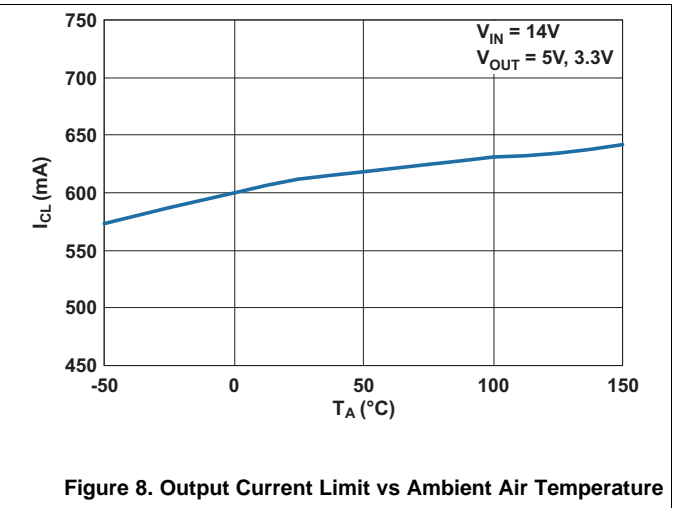

Figure 8. Output Current Limit vs Ambient Air Temperature

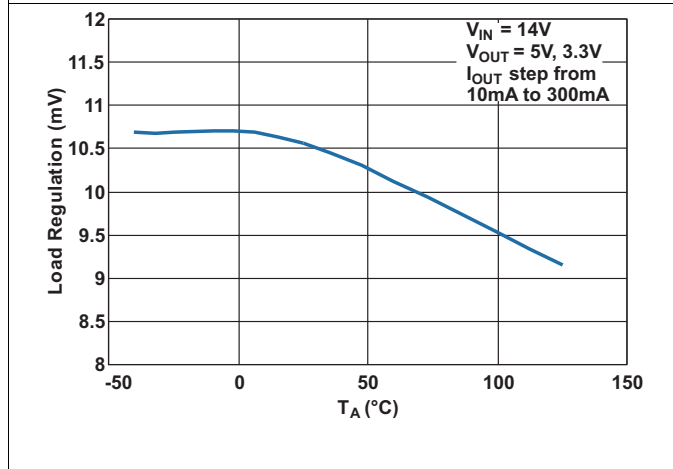

Figure 9. Load Regulation vs Ambient Air Temperature

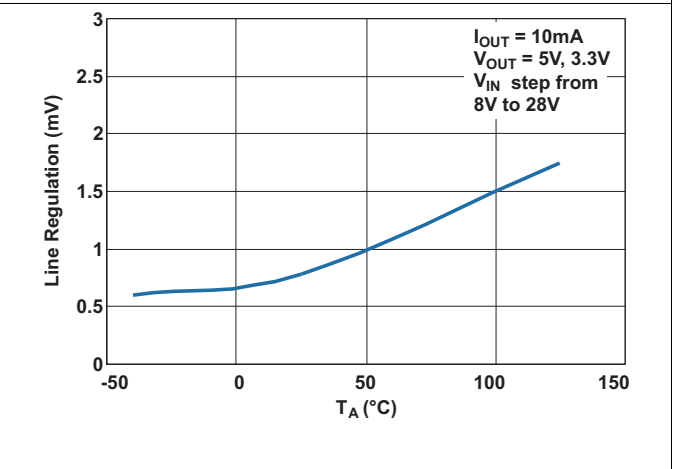

Figure 10. Line Regulation vs Ambient Air Temperature

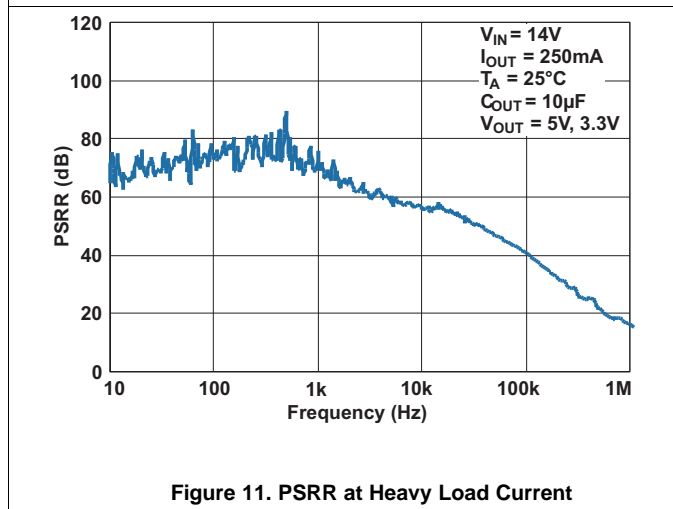

Figure 11. PSRR at Heavy Load Current

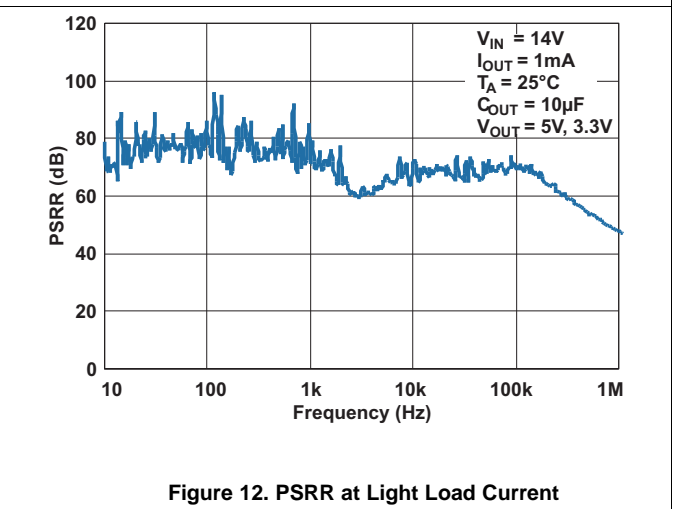
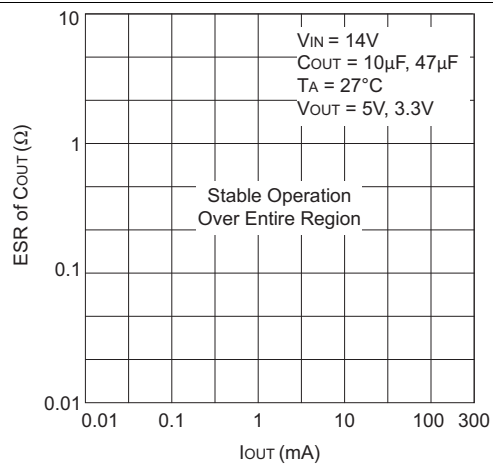

Figure 12. PSRR at Light Load Current

Typical Characteristics (continued)



**Figure 13. ESR Stability vs Load Current
for TPS7A60-Q1 and TPS7A61-Q1**

8 Detailed Description

8.1 Overview

The TPS7A60-Q1 and TPS7A61-Q1 devices comprise a family of monolithic low-dropout linear voltage regulators with integrated reset functionality. These voltage regulators are designed for low power consumption and quiescent current less than 25 μA in light-load applications. These devices are well-suited in power supplies for microprocessors and microcontrollers because of an integrated reset delay, also called power-on-reset delay.

These devices are available in two fixed output-voltage (3.3-V and 5-V) versions as follows:

- Programmable reset delay version (TPS7A60-Q1)
- Enable version (TPS7A61-Q1)

8.2 Functional Block Diagrams

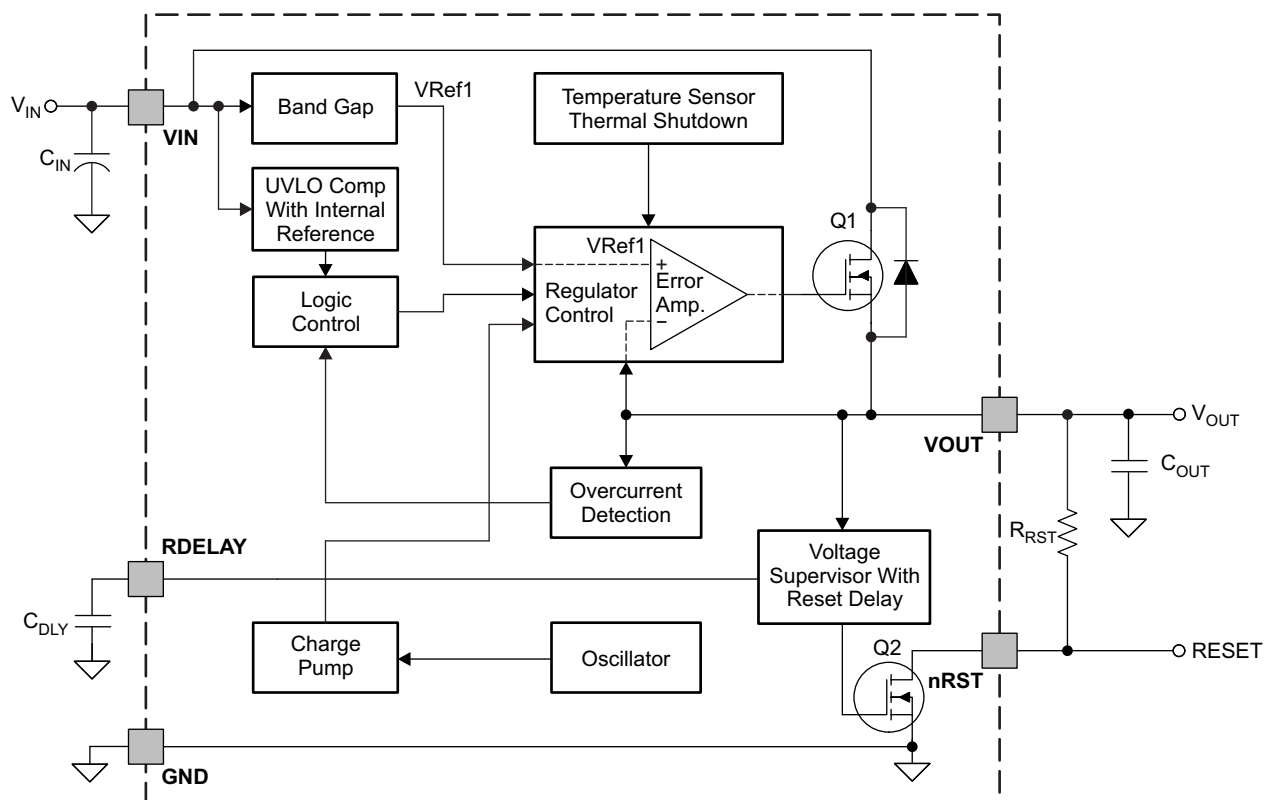
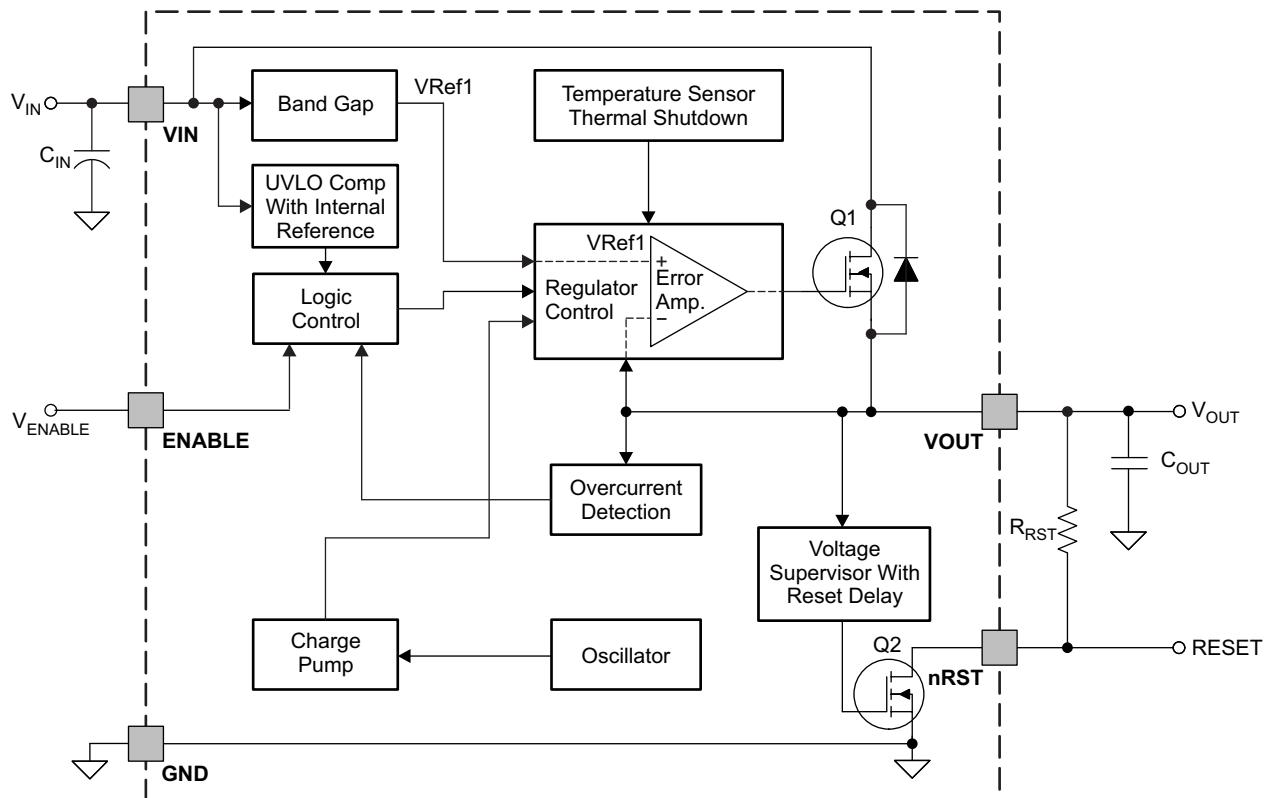

Figure 14. TPS7A60-Q1 Functional Block Diagram

Functional Block Diagrams (continued)

Figure 15. TPS7A61-Q1 Functional Block Diagram

8.3 Feature Description

The following section describes the features of TPS7A60-Q1 and TPS7A61-Q1 voltage regulators in detail.

8.3.1 Reset Delay and Reset Output

Reset delay is implemented when the device starts up to indicate that output voltage is stable and in regulation, and also when the output recovers from a negative voltage spike due to a load step or a dip in the input voltage for a specified duration. The reset-delay timer is initialized when the voltage at the output (V_{OUT}) exceeds 93% of the regulated output voltage (3.3 V or 5 V, as applicable). The reset output (nRST) is asserted high after the power-on-reset delay (t_{POR}) has elapsed. If the regulated output voltage falls below 93% of the set level, nRST is asserted low after a short de-glitch time of approximately 5.5 μ s (typical).

For TPS7A60-Q1 devices, the reset-delay time can be programmed by connecting an external capacitor (C_{DLY}) to the RDELAY pin. The delay time is given by [Equation 1](#):

$$t_{POR} = \frac{C_{DLY} \times 3}{1 \times 10^{-6}}$$

where

- t_{POR} = reset delay time in seconds
 - C_{DLY} = reset delay capacitor value in farads, 100 pF to 100 nF
- (1)

In TPS7A61xx devices, there is no RDELAY pin, and the reset-delay time is preset internally (250 μ s typical).

Feature Description (continued)

During power up, the regulator incorporates a protection scheme to limit the current through the pass element and output capacitor. When the input voltage exceeds a certain threshold ($V_{IN(POWERUP)}$) level, the output voltage begins to ramp as shown in Figure 16 and Figure 17. When the output voltage reaches the power-on-reset threshold ($V_{TH(POR)}$) level, a constant output current charges an external capacitor (C_{DLY}) to an internal threshold ($V_{TH(RDELAY)}$) voltage level. Then, nRST is asserted high and C_{DLY} is discharged through an internal load. This allows C_{DLY} to charge from approximately 0 V during the next power cycle. If no external capacitor is connected, the delay time is preset internally. This is shown in Figure 16.

In TPS7A60-Q1 devices, if the C_{DLY} capacitor is not connected to the RDELAY pin, the reset-delay time is set internally. This is shown in Figure 17.

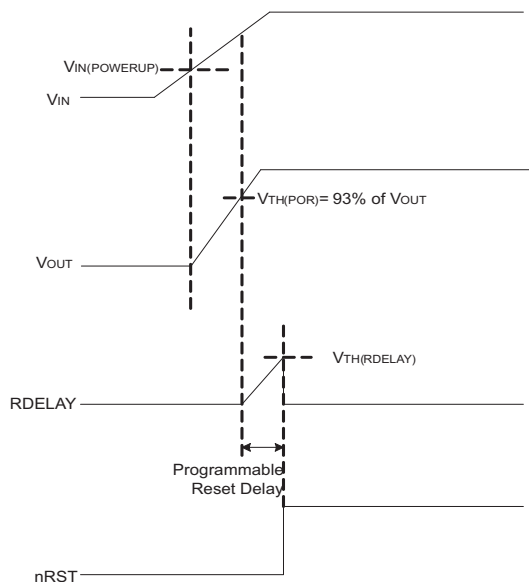

Figure 16. Power Up and Reset-Delay Function With the C_{DLY} Capacitor Connected to the RDELAY Pin for TPS7A60-Q1

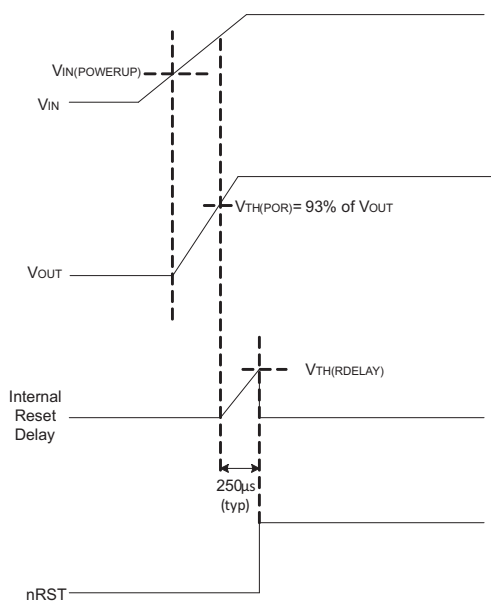

Figure 17. Power Up and Reset Delay Function With the C_{DLY} Capacitor Not Connected or Available in TPS7A60-Q1 and TPS7A61-Q1, Respectively

Feature Description (continued)

In case of negative transients in the input voltage (V_{IN}), the reset signal is asserted low only if the output (V_{OUT}) drops and stays below the reset threshold level ($V_{TH(POR)}$) for more than the de-glitch time ($t_{DEGLITCH}$). This is shown in Figure 18.

While $nRST$ is low, if the input voltage returns to the nominal operating voltage, the normal power-up sequence is followed. $nRST$ is asserted high, only if the output voltage exceeds the reset-threshold voltage ($V_{TH(POR)}$) and the reset-delay time (t_{POR}) has elapsed. This is shown in the shaded region of Figure 18.

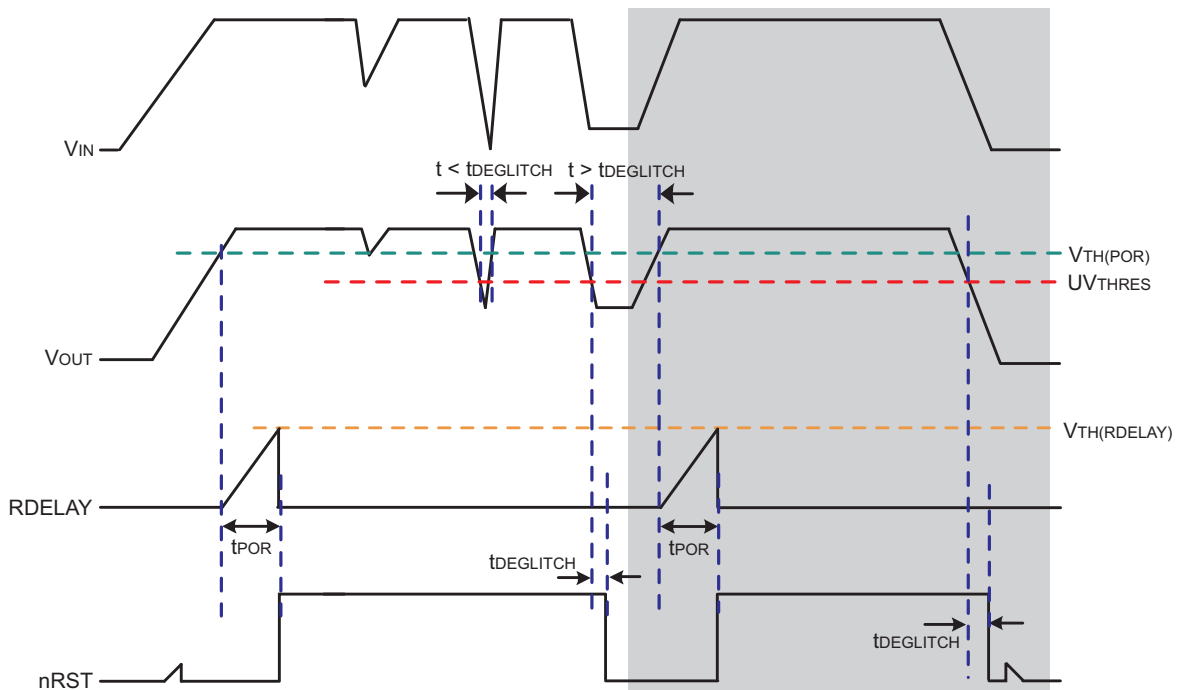

Figure 18. Conditions for Activation of Reset

8.3.2 Charge Pump Operation

These devices have an internal charge pump which turns on or off depending on the input voltage and the output current. The charge-pump switching circuitry does not cause conducted emissions to exceed required thresholds on the input-voltage line. For a given output current, the charge pump stays on at lower input voltages and turns off at higher input voltages. The charge-pump switching thresholds are hysteretic. Figure 19 and Figure 20 show typical switching thresholds for the charge pump at light ($I_{OUT} < \text{approximately } 2 \text{ mA}$) and heavy ($I_{OUT} > \text{approximately } 2 \text{ mA}$) loads, respectively.

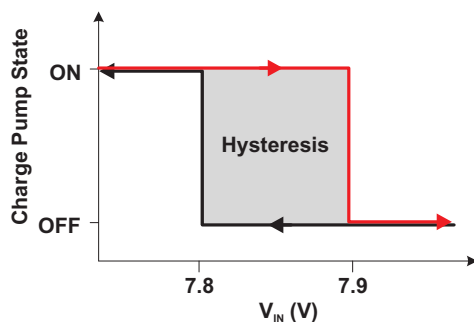

Figure 19. Charge Pump Operation at Light Loads

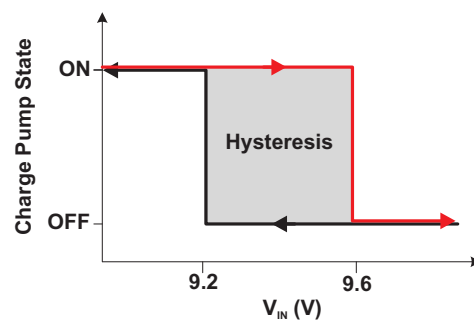

Figure 20. Charge Pump Operation at Heavy Loads

Feature Description (continued)

8.3.3 Undervoltage Shutdown

These devices have an integrated undervoltage lockout (UVLO) circuit to shut down the output if the input voltage (V_{IN}) falls below an internally fixed UVLO threshold level ($V_{IN-UVLO}$). This ensures that the regulator is not latched into an unknown state during low-input-voltage conditions. The regulator powers up when the input voltage exceeds the $V_{IN(POWERUP)}$ level.

8.3.4 Low-Voltage Tracking

At low input voltages, the regulator drops out of regulation, and the output voltage tracks the input minus a voltage based on the load current (I_{OUT}) and switch resistance (R_{SW}). This allows for a smaller input capacitor and can possibly eliminate the need of using a boost converter during cold-crank conditions.

8.3.5 Integrated Fault Protection

These devices feature integrated fault protection to make them ideal for use in automotive applications. In order to keep them in a safe area of operation during certain fault conditions, internal current-limit protection and current-limit foldback are used to limit the maximum output current. This protects them from excessive power dissipation. For example, during a short-circuit condition on the output, current through the pass element is limited to I_{CL} to protect the device from excessive power dissipation.

8.3.6 Thermal Shutdown

These devices incorporate a thermal shutdown (TSD) circuit as a protection from overheating. For continuous normal operation, the junction temperature should not exceed the TSD trip point. If the junction temperature exceeds the TSD trip point, the output is turned off. When the junction temperature falls below the TSD trip point, the output is turned on again. This is shown in [Figure 21](#).

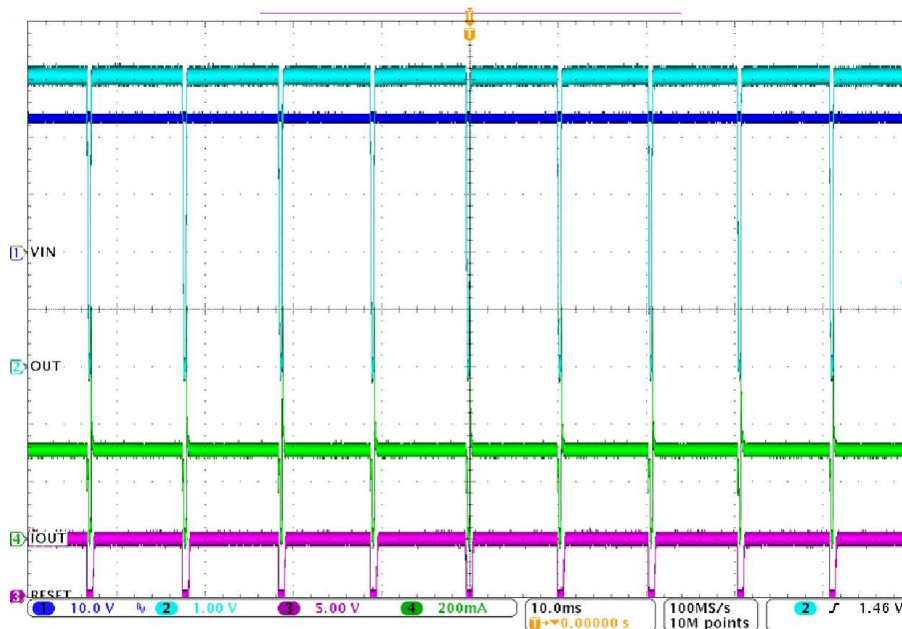

$$V_{IN} = 24 \text{ V}$$

$$I_{OUT} = 300 \text{ mA}$$

$$V_{OUT} = 5 \text{ V}$$

Figure 21. Thermal Cycling Waveform for the TPS7A6150-Q1

8.4 Device Functional Modes

8.4.1 Low-Power Mode

At light loads and high input voltages ($V_{IN} >$ approximately 8 V such that charge pump is off), the device operates in low-power mode and the quiescent current consumption is reduced to 25 μA (typical) as shown in [Table 1](#).

Table 1. Typical Quiescent Current Consumption

I_{OUT}	CHARGE PUMP ON	CHARGE PUMP OFF
$I_{OUT} <$ approximately 2 mA (light load)	250 μA	25 μA (low-power mode)
$I_{OUT} >$ approximately 2 mA (heavy load)	280 μA	70 μA

8.4.2 Sleep Mode (TPS7A61-Q1 Only)

The enable falling edge is 0.8 V (minimum). The device operates in the sleep mode by holding the ENABLE pin below that voltage, and the quiescent current consumption is reduced to 3 μA (maximum) as shown in [Electrical Characteristics](#).

8.4.3 Regulation Mode

When the input voltage is above 11 V, with the ENABLE pin pulled higher than 2.5 V, the device operates in regulation mode and outputs the nominal voltage.

9 Application and Implementation

NOTE

Information in the following applications sections is not part of the TI component specification, and TI does not warrant its accuracy or completeness. TI's customers are responsible for determining suitability of components for their purposes. Customers should validate and test their design implementation to confirm system functionality.

9.1 Application Information

The TPS7A60-Q1 and TPS7A61-Q1 devices are 300-mA low-dropout linear regulators designed for up to 40-V V_{IN} operation with only 25- μ A quiescent current at no load. There are specific EVMs designed for these devices to enable evaluation of all the functions of the devices. Both the EVM and its user guide are available on the product folder as well.

9.2 Typical Applications

Figure 22 and Figure 24 show typical application circuits for the TPS7A60-Q1 and TPS7A61-Q1, respectively. One may use different values of external components, depending on the end application. An application may require a larger output capacitor during fast load steps in order to prevent reset from occurring. TI recommends a low-ESR ceramic capacitor with dielectric of type X5R or X7R.

9.2.1 TPS7A60-Q1 Typical Application

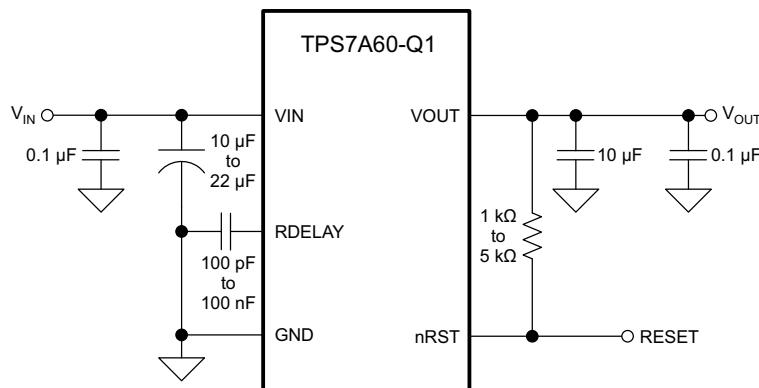

Figure 22. Typical Application Schematic for the TPS7A60-Q1 Device

9.2.1.1 Design Requirements

For this design example, use the parameters listed in Table 2.

Table 2. TPS7A60-Q1 Design Parameters

DESIGN PARAMETER	EXAMPLE VALUE
Input voltage range	11 V to 40 V
Output voltage	3.3 V (for TPS7A6033-Q1) or 5 V (for TPS7A6050-Q1)
Output current rating	300 mA
Output capacitor range	10 μ F to 47 μ F
Output-capacitor ESR range	10 m Ω to 10 Ω
RESET-delay capacitor range	100 pF to 100 nF

9.2.1.2 Detailed Design Procedure

To begin the design process, determine the following:

- Input voltage range
- Output voltage
- Output current rating
- Input capacitor
- Output capacitor

9.2.1.2.1 Input Capacitor

The device requires an input bypass capacitor, the value of which depends on the application. The typical recommended value for the bypass capacitor is 10 μF . The voltage rating must be greater than the maximum input voltage.

9.2.1.2.2 Output Capacitor

The device requires an output capacitor to stabilize the output voltage. TI recommends to selecting a capacitor between 10 μF and 47 μF with ESR range from 10 $\text{m}\Omega$ to 10 Ω .

9.2.1.3 Application Curve

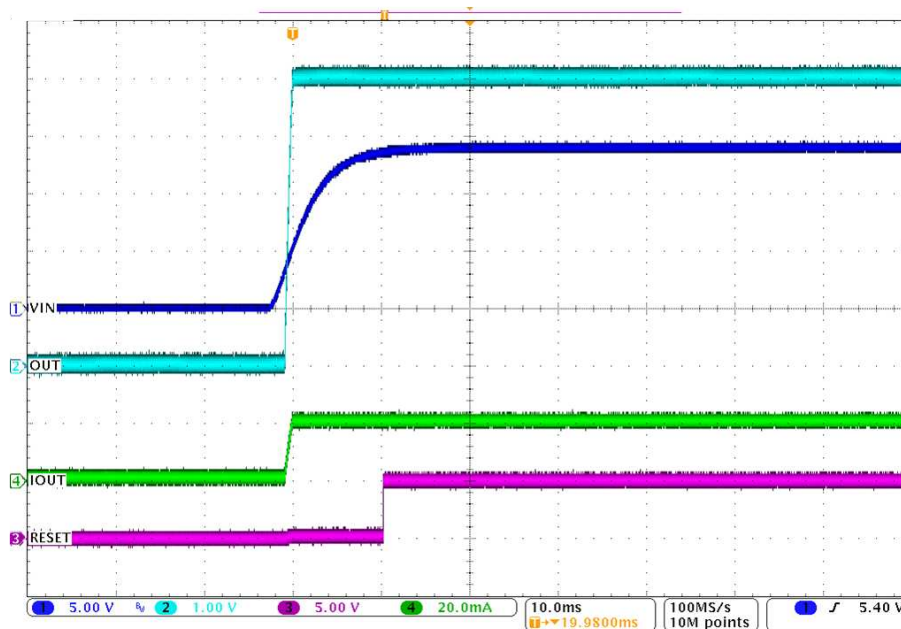

Figure 23. Power Up ($V_{\text{OUT}} = 5\text{ V}$) With 10-ms RESET Delay, 10 ms/div, $I_L = 20\text{ mA}$

9.2.2 TPS7A61-Q1 Typical Application

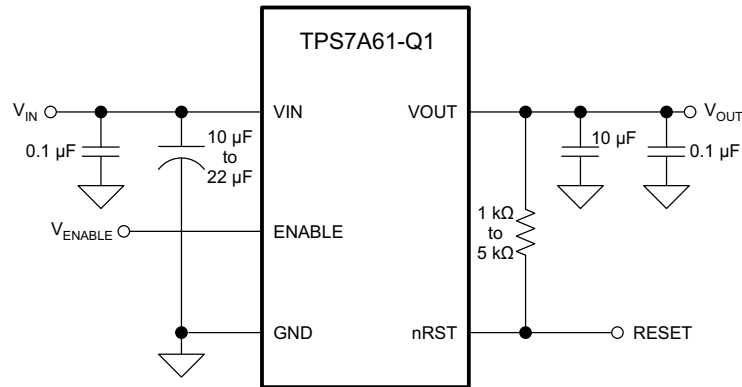

Figure 24. Typical Application Schematic for the TPS7A61-Q1 Device

9.2.2.1 Design Requirements

For this design example, use the parameters listed in [Table 3](#).

Table 3. TPS7A61-Q1 Design Parameters

DESIGN PARAMETER	EXAMPLE VALUE
Input voltage range	11 V to 40 V
Output voltage	3.3 V (for TPS7A6133-Q1) or 5 V (for TPS7A6150-Q1)
Output current rating	300 mA
Output capacitor range	10 µF to 47 µF
Output-capacitor ESR range	10 mΩ to 10 Ω

9.2.2.2 Detailed Design Procedure

To begin the design process, determine the following:

- Input voltage range
- Output voltage
- Output current rating
- Input capacitor
- Output capacitor

9.2.2.3 Application Curve

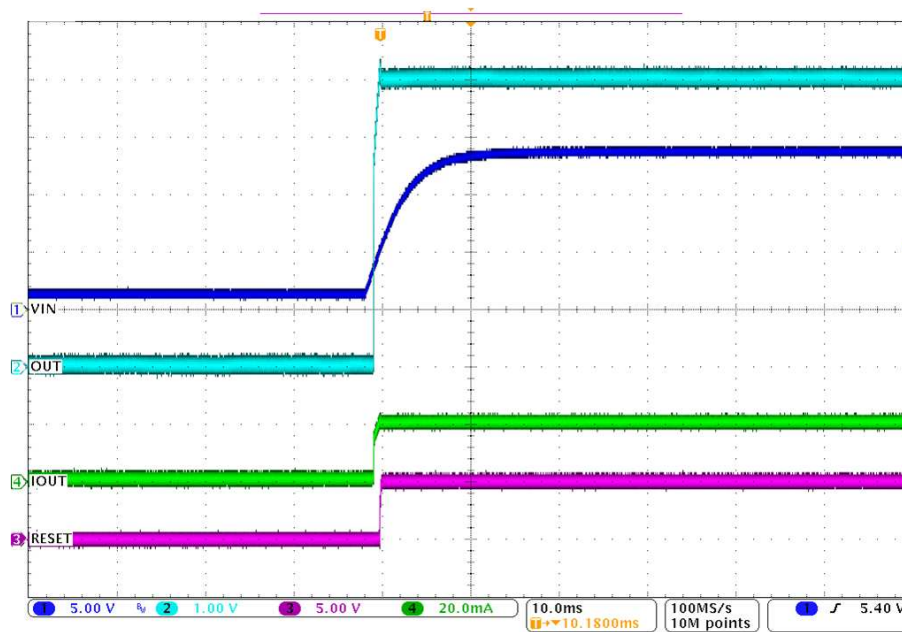

Figure 25. Power Up ($V_{OUT} = 5\text{ V}$), 10 ms/div, $I_L = 20\text{ mA}$

10 Power Supply Recommendations

Design of the device is for operation from an input voltage supply with a range between 4 V and 40 V. This input supply must be well regulated. If the input supply is located more than a few inches from the TPS7A60-Q1 or TPS7A61-Q1 device, TI recommends adding an electrolytic capacitor with a value of 22 μ F and a ceramic bypass capacitor at the input.

11 Layout

11.1 Layout Guidelines

For the LDO power supply, especially these high voltage and large current ones, layout is an important step. If layout is not carefully designed, the regulator could not deliver enough output current because of the thermal limitation. To improve the thermal performance of the device, and maximize the current output at high ambient temperature, it is recommended to spread the thermal pad as large as possible and put enough thermal vias on the thermal pad. [Figure 29](#) and [Figure 30](#) show an example layout.

11.1.1 Power Dissipation and Thermal Considerations

Power dissipated in the device can be calculated using [Equation 2](#).

$$P_D = I_{OUT} \times (V_{IN} - V_{OUT}) + I_{QUIESCENT} \times V_{IN}$$

where

- P_D = continuous power dissipation
- I_{OUT} = output current
- V_{IN} = input voltage
- V_{OUT} = output voltage
- $I_{QUIESCENT}$ = quiescent current

(2)

As $I_{QUIESCENT} \ll I_{OUT}$, therefore, the term $I_{QUIESCENT} \times V_{IN}$ in [Equation 2](#) can be ignored.

For a device under operation at a given ambient air temperature (T_A), the junction temperature (T_J) can be calculated using [Equation 3](#).

$$T_J = T_A + (R_{\theta JA} \times P_D)$$

where

- $R_{\theta JA}$ = junction-to-ambient-air thermal impedance

(3)

Layout Guidelines (continued)

The rise in junction temperature due to power dissipation can be calculated using Equation 4.

$$\Delta T = T_J - T_A = (R_{\theta JA} \times P_D) \tag{4}$$

For a given maximum junction temperature (T_{J-Max}), the maximum ambient air temperature (T_{A-Max}) at which the device can operate can be calculated using Equation 5.

$$T_{A-Max} = T_{J-Max} - (R_{\theta JA} \times P_D) \tag{5}$$

Example:

If $I_{OUT} = 100 \text{ mA}$, $V_{OUT} = 5 \text{ V}$, $V_{IN} = 14 \text{ V}$, $I_{QUIESCENT} = 250 \text{ }\mu\text{A}$ and $R_{\theta JA} = 30^\circ\text{C/W}$, the continuous power dissipated in the device is 0.9 W. The rise in junction temperature due to power dissipation is 27°C. For a maximum junction temperature of 150°C, maximum ambient air temperature at which the device can operate is 123°C.

For adequate heat dissipation, it is recommended to solder the thermal pad (exposed heat sink) to a thermal land pad on the PCB. Doing this provides a heat conduction path from the die to the PCB and reduces overall package thermal resistance. Power derating curves for the TPS7A60-Q1 and TPS7A61-Q1 family of devices in the KTT (TO-263) and KVU (TO-252) packages are shown in Figure 26.

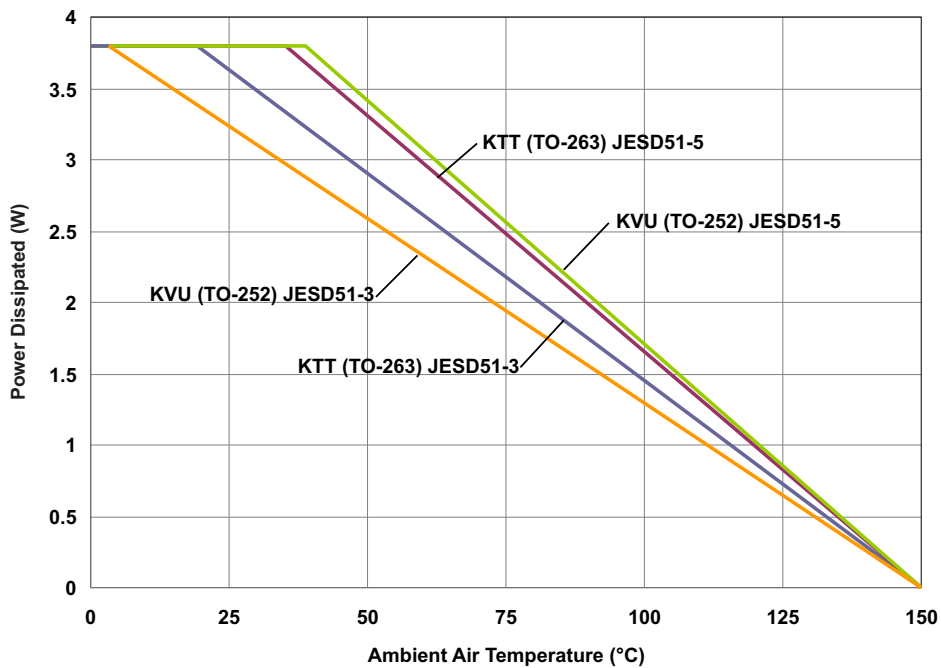

Figure 26. Power Derating Curves

For optimum thermal performance, TI recommends to use a high-K PCB with thermal vias between the ground plane and solder pad or thermal land pad. This is shown in Figure 27 (a) and (b). Further, the heat-spreading capabilities of a PCB can be considerably improved by using a thicker ground plane and a thermal land pad with a larger surface area.

Layout Guidelines (continued)

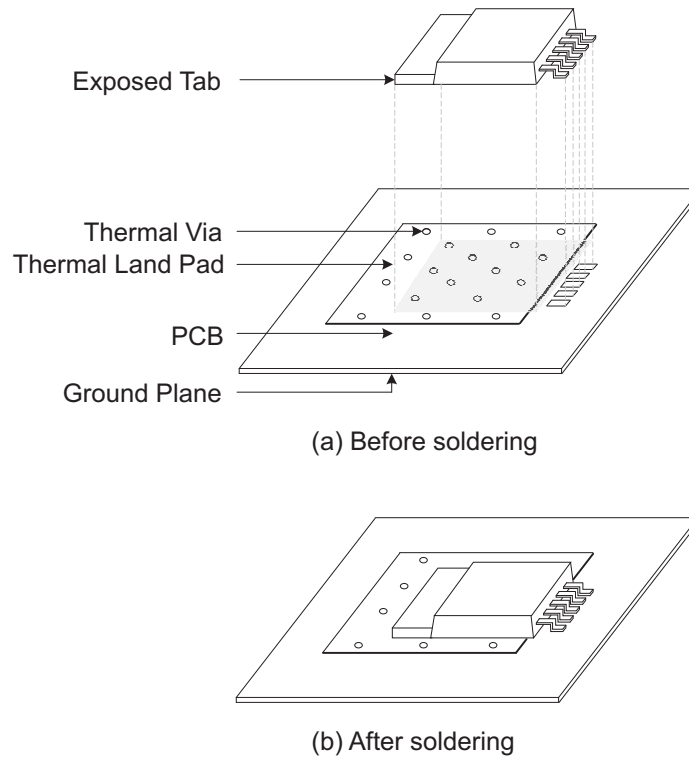

Figure 27. Using Multilayer PCB and Thermal Vias For Adequate Heat Dissipation

Keeping other factors constant, surface area of the thermal land pad contributes to heat dissipation only to a certain extent. Figure 28 shows the variation of $R_{\theta JA}$ with surface area of the thermal land pad (soldered to the exposed pad) for KTT and KVU packages.

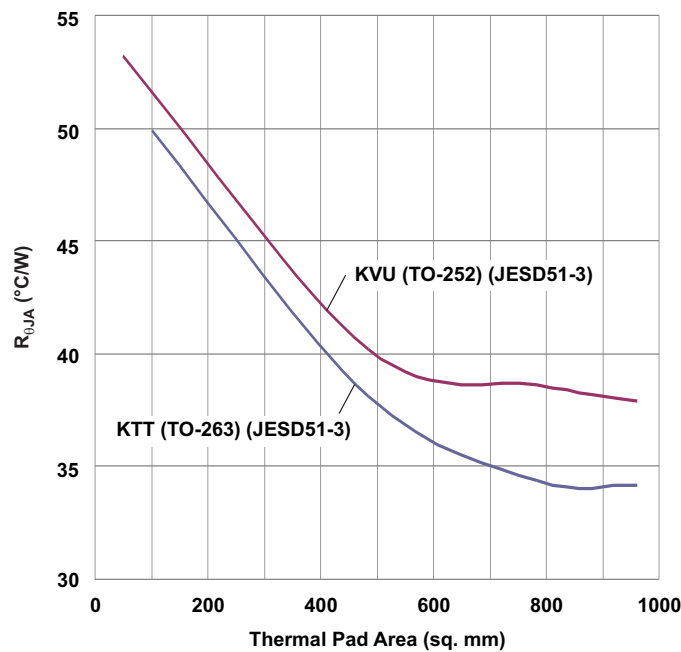

Figure 28. $R_{\theta JA}$ vs Thermal Pad Area

11.2 Layout Examples

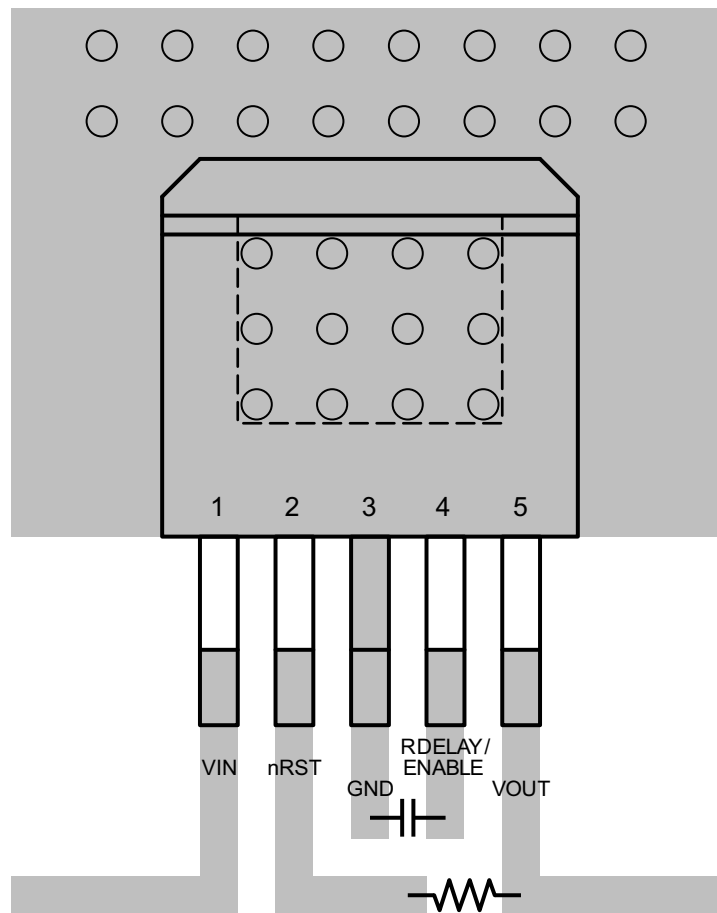

Figure 29. Layout Recommendation for 5-Pin KTT Package

Layout Examples (continued)

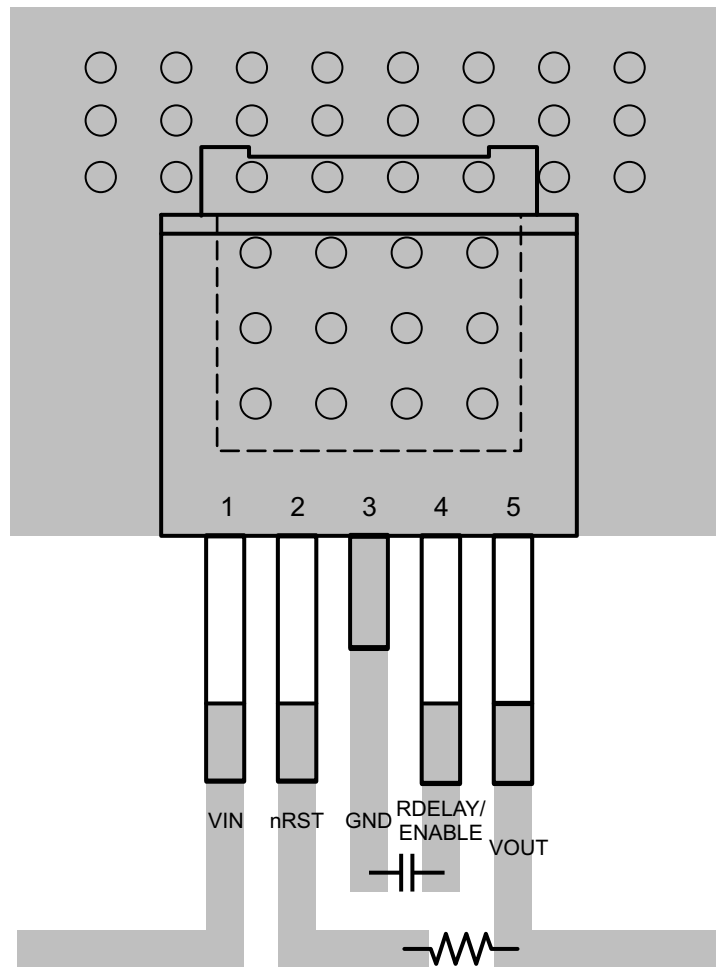

Figure 30. Layout Recommendation for 5-pin KVV package

12 Device and Documentation Support

12.1 Related Links

The table below lists quick access links. Categories include technical documents, support and community resources, tools and software, and quick access to order now.

Table 4. Related Links

PARTS	PRODUCT FOLDER	ORDER NOW	TECHNICAL DOCUMENTS	TOOLS & SOFTWARE	SUPPORT & COMMUNITY
TPS7A60-Q1	Click here	Click here	Click here	Click here	Click here
TPS7A61-Q1	Click here	Click here	Click here	Click here	Click here

12.2 Receiving Notification of Documentation Updates

To receive notification of documentation updates, navigate to the device product folder on ti.com. In the upper right corner, click on *Alert me* to register and receive a weekly digest of any product information that has changed. For change details, review the revision history included in any revised document.

12.3 Community Resources

The following links connect to TI community resources. Linked contents are provided "AS IS" by the respective contributors. They do not constitute TI specifications and do not necessarily reflect TI's views; see TI's [Terms of Use](#).

TI E2E™ Online Community *TI's Engineer-to-Engineer (E2E) Community*. Created to foster collaboration among engineers. At e2e.ti.com, you can ask questions, share knowledge, explore ideas and help solve problems with fellow engineers.

Design Support *TI's Design Support* Quickly find helpful E2E forums along with design support tools and contact information for technical support.

12.4 Trademarks

E2E is a trademark of Texas Instruments.
All other trademarks are the property of their respective owners.

12.5 Electrostatic Discharge Caution



This integrated circuit can be damaged by ESD. Texas Instruments recommends that all integrated circuits be handled with appropriate precautions. Failure to observe proper handling and installation procedures can cause damage.

ESD damage can range from subtle performance degradation to complete device failure. Precision integrated circuits may be more susceptible to damage because very small parametric changes could cause the device not to meet its published specifications.

12.6 Glossary

[SLYZ022](#) — *TI Glossary*.

This glossary lists and explains terms, acronyms, and definitions.

13 Mechanical, Packaging, and Orderable Information

The following pages include mechanical, packaging, and orderable information. This information is the most-current data available for the designated devices. This data is subject to change without notice and without revision of this document. For browser-based versions of this data sheet, see the left-hand navigation pane.

PACKAGING INFORMATION

Orderable Device	Status (1)	Package Type	Package Drawing	Pins	Package Qty	Eco Plan (2)	Lead/Ball Finish (6)	MSL Peak Temp (3)	Op Temp (°C)	Device Marking (4/5)	Samples
TPS7A6033QKTTRQ1	ACTIVE	DDPAK/ TO-263	KTT	5	500	Green (RoHS & no Sb/Br)	CU SN	Level-3-245C-168 HR	-40 to 125	7A6033Q1	Samples
TPS7A6033QKVURQ1	ACTIVE	TO-252	KVU	5	2500	Green (RoHS & no Sb/Br)	CU SN	Level-3-260C-168 HR	-40 to 125	7A6033Q1	Samples
TPS7A6050QKTTRQ1	ACTIVE	DDPAK/ TO-263	KTT	5	500	Green (RoHS & no Sb/Br)	CU SN	Level-3-245C-168 HR	-40 to 125	7A6050Q1	Samples
TPS7A6050QKVURQ1	ACTIVE	TO-252	KVU	5	2500	Green (RoHS & no Sb/Br)	CU SN	Level-3-260C-168 HR	-40 to 125	7A6050Q1	Samples
TPS7A6133QKVURQ1	ACTIVE	TO-252	KVU	5	2500	Green (RoHS & no Sb/Br)	CU SN	Level-3-260C-168 HR	-40 to 125	7A6133Q1	Samples
TPS7A6150QKVURQ1	ACTIVE	TO-252	KVU	5	2500	Green (RoHS & no Sb/Br)	CU SN	Level-3-260C-168 HR	-40 to 125	7A6150Q1	Samples

(1) The marketing status values are defined as follows:

ACTIVE: Product device recommended for new designs.

LIFEBUY: TI has announced that the device will be discontinued, and a lifetime-buy period is in effect.

NRND: Not recommended for new designs. Device is in production to support existing customers, but TI does not recommend using this part in a new design.

PREVIEW: Device has been announced but is not in production. Samples may or may not be available.

OBSOLETE: TI has discontinued the production of the device.

(2) **RoHS:** TI defines "RoHS" to mean semiconductor products that are compliant with the current EU RoHS requirements for all 10 RoHS substances, including the requirement that RoHS substance do not exceed 0.1% by weight in homogeneous materials. Where designed to be soldered at high temperatures, "RoHS" products are suitable for use in specified lead-free processes. TI may reference these types of products as "Pb-Free".

RoHS Exempt: TI defines "RoHS Exempt" to mean products that contain lead but are compliant with EU RoHS pursuant to a specific EU RoHS exemption.

Green: TI defines "Green" to mean the content of Chlorine (Cl) and Bromine (Br) based flame retardants meet JS709B low halogen requirements of <=1000ppm threshold. Antimony trioxide based flame retardants must also meet the <=1000ppm threshold requirement.

(3) MSL, Peak Temp. - The Moisture Sensitivity Level rating according to the JEDEC industry standard classifications, and peak solder temperature.

(4) There may be additional marking, which relates to the logo, the lot trace code information, or the environmental category on the device.

(5) Multiple Device Markings will be inside parentheses. Only one Device Marking contained in parentheses and separated by a "-" will appear on a device. If a line is indented then it is a continuation of the previous line and the two combined represent the entire Device Marking for that device.

⁽⁶⁾ Lead/Ball Finish - Orderable Devices may have multiple material finish options. Finish options are separated by a vertical ruled line. Lead/Ball Finish values may wrap to two lines if the finish value exceeds the maximum column width.

Important Information and Disclaimer:The information provided on this page represents TI's knowledge and belief as of the date that it is provided. TI bases its knowledge and belief on information provided by third parties, and makes no representation or warranty as to the accuracy of such information. Efforts are underway to better integrate information from third parties. TI has taken and continues to take reasonable steps to provide representative and accurate information but may not have conducted destructive testing or chemical analysis on incoming materials and chemicals. TI and TI suppliers consider certain information to be proprietary, and thus CAS numbers and other limited information may not be available for release.

In no event shall TI's liability arising out of such information exceed the total purchase price of the TI part(s) at issue in this document sold by TI to Customer on an annual basis.

TAPE AND REEL INFORMATION

QUADRANT ASSIGNMENTS FOR PIN 1 ORIENTATION IN TAPE

*All dimensions are nominal

Device	Package Type	Package Drawing	Pins	SPQ	Reel Diameter (mm)	Reel Width W1 (mm)	A0 (mm)	B0 (mm)	K0 (mm)	P1 (mm)	W (mm)	Pin1 Quadrant
TPS7A6033QKTTRQ1	DDPAK/TO-263	KTT	5	500	330.0	24.4	10.6	15.8	4.9	16.0	24.0	Q2
TPS7A6033QKVURQ1	TO-252	KVU	5	2500	330.0	16.4	6.9	10.5	2.7	8.0	16.0	Q2
TPS7A6050QKTTRQ1	DDPAK/TO-263	KTT	5	500	330.0	24.4	10.6	15.8	4.9	16.0	24.0	Q2
TPS7A6050QKVURQ1	TO-252	KVU	5	2500	330.0	16.4	6.9	10.5	2.7	8.0	16.0	Q2
TPS7A6133QKVURQ1	TO-252	KVU	5	2500	330.0	16.4	6.9	10.5	2.7	8.0	16.0	Q2
TPS7A6150QKVURQ1	TO-252	KVU	5	2500	330.0	16.4	6.9	10.5	2.7	8.0	16.0	Q2

TAPE AND REEL BOX DIMENSIONS



*All dimensions are nominal

Device	Package Type	Package Drawing	Pins	SPQ	Length (mm)	Width (mm)	Height (mm)
TPS7A6033QKTTRQ1	DDPAK/TO-263	KTT	5	500	340.0	340.0	38.0
TPS7A6033QKVURQ1	TO-252	KVU	5	2500	340.0	340.0	38.0
TPS7A6050QKTTRQ1	DDPAK/TO-263	KTT	5	500	340.0	340.0	38.0
TPS7A6050QKVURQ1	TO-252	KVU	5	2500	340.0	340.0	38.0
TPS7A6133QKVURQ1	TO-252	KVU	5	2500	340.0	340.0	38.0
TPS7A6150QKVURQ1	TO-252	KVU	5	2500	340.0	340.0	38.0

MECHANICAL DATA

KVU (R-PSFM-G5)

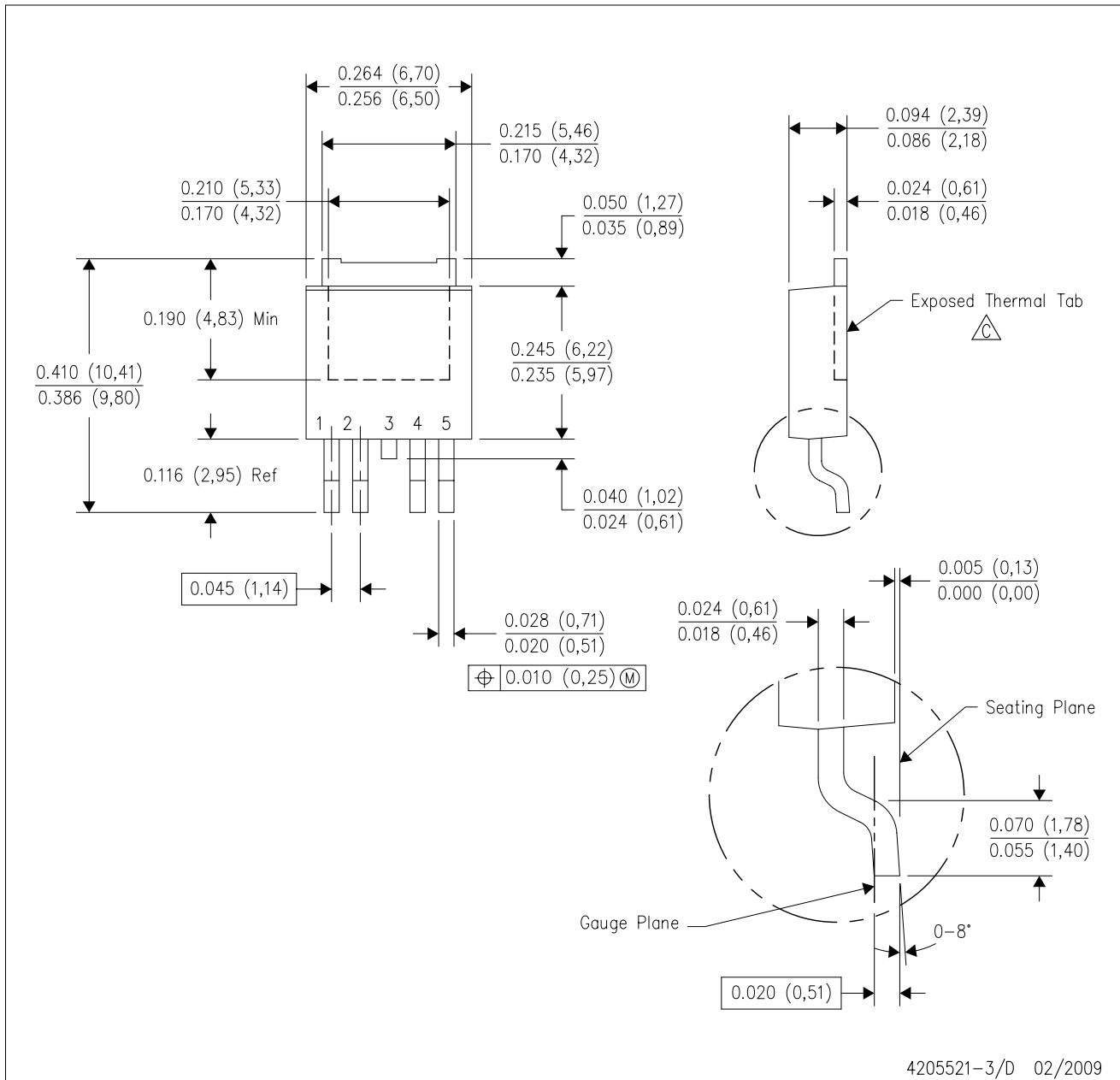
PLASTIC FLANGE-MOUNT PACKAGE



- NOTES:
- A. All linear dimensions are in inches (millimeters).
 - B. This drawing is subject to change without notice.
 - $\triangle C$ The center lead is in electrical contact with the exposed thermal tab.
 - D. Body Dimensions do not include mold flash or protrusions. Mold flash and protrusion shall not exceed 0.006 (0,15) per side.
 - E. Falls within JEDEC TO-252 variation AD.

KVU (R-PSFM-G5)

PLASTIC FLANGE MOUNT PACKAGE

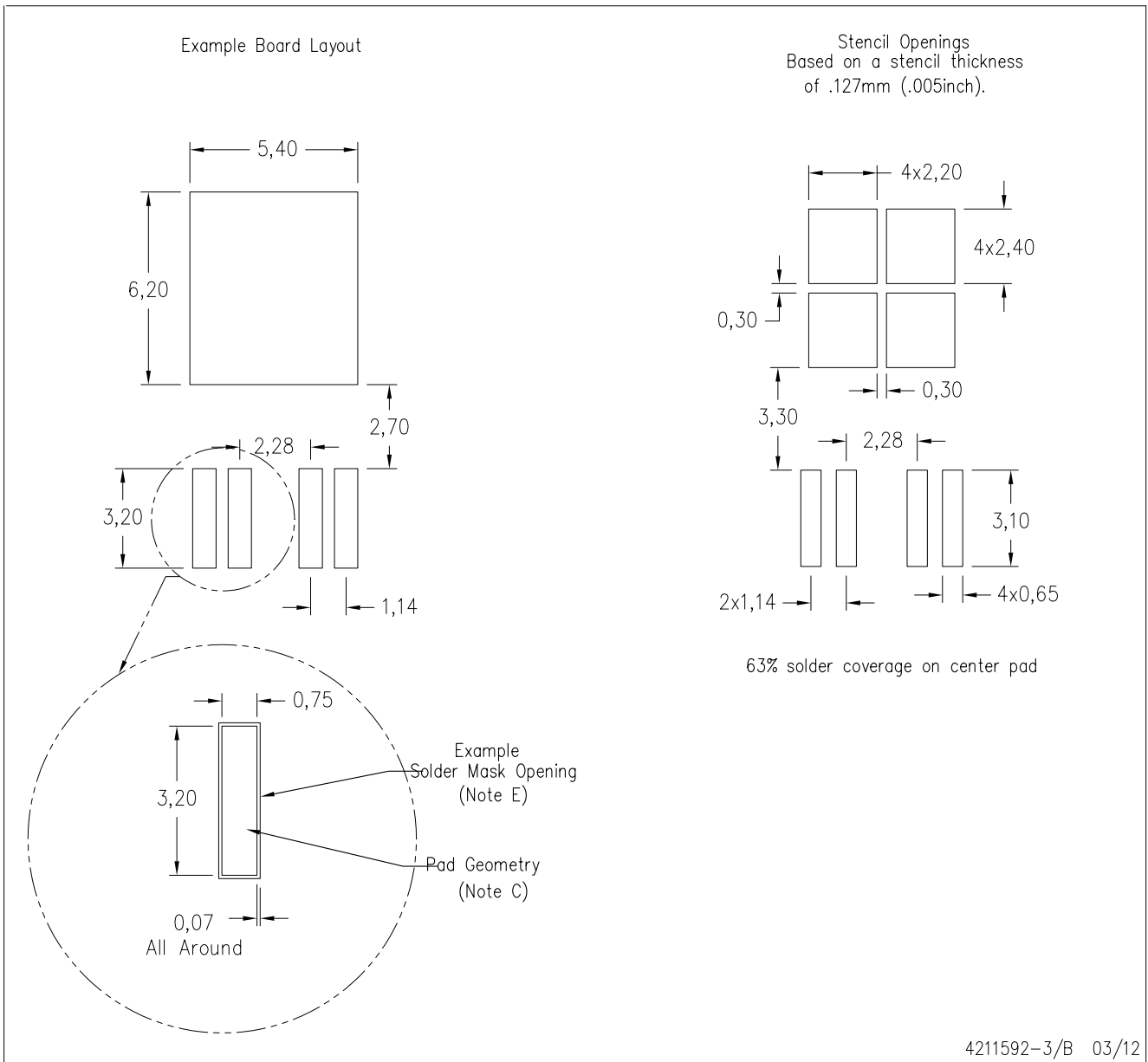

- NOTES:
- A. All linear dimensions are in millimeters.
 - B. This drawing is subject to change without notice.
 - C. Publication IPC-SM-782 is an alternate information source for PCB land pattern designs.
 - D. Laser cutting apertures with trapezoidal walls and also rounding corners will offer better paste release. Customers should contact their board assembly site for stencil design recommendations. Refer to IPC-7525 for other stencil recommendations.
 - E. Customers should contact their board fabrication site for recommended solder mask tolerances and via tenting recommendations for vias placed in thermal pad.

KTT (R-PSFM-G5)

PLASTIC FLANGE-MOUNT PACKAGE

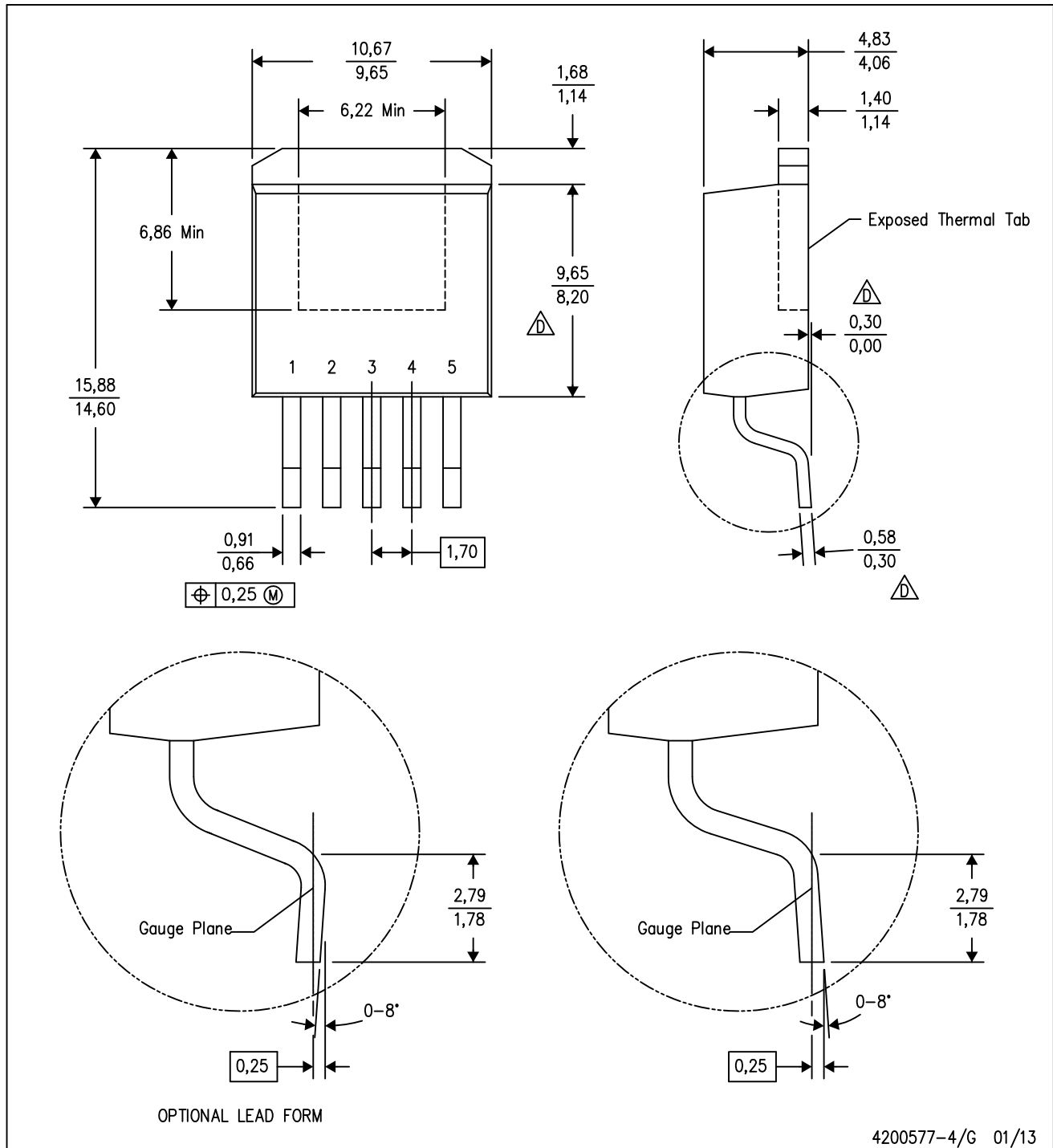

4200577-4/G 01/13

- NOTES:
- A. All linear dimensions are in millimeters.
 - B. This drawing is subject to change without notice.
 - C. Body dimensions do not include mold flash or protrusion. Mold flash or protrusion not to exceed 0.005 (0,13) per side.
- \triangle Falls within JEDEC TO-263 variation BA, except minimum lead thickness, maximum seating height, and minimum body length.

KTT (R-PSFM-G5)

PLASTIC FLANGE-MOUNT PACKAGE

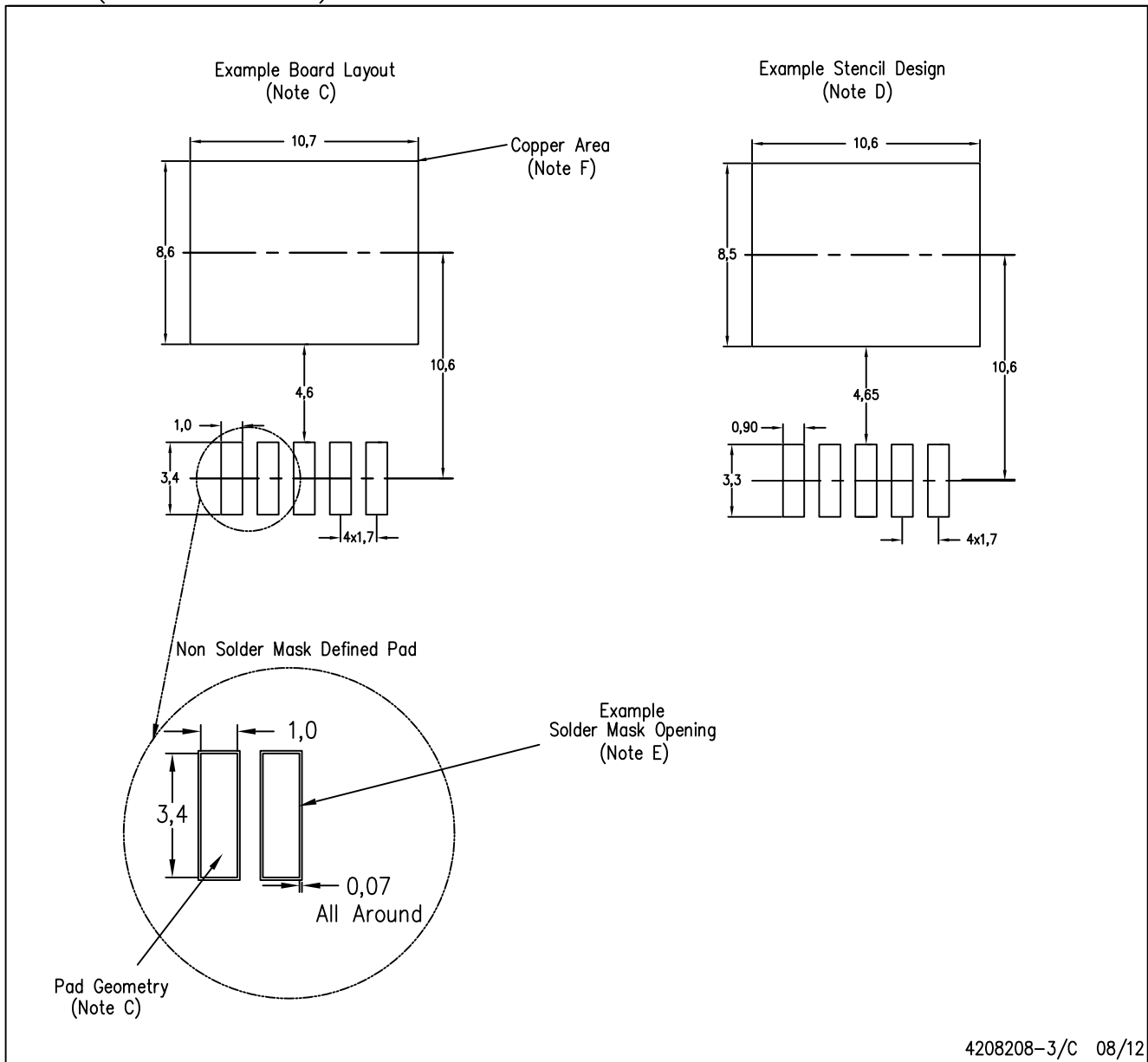

- NOTES:
- All linear dimensions are in millimeters.
 - This drawing is subject to change without notice.
 - Publication IPC-SM-782 is recommended for alternate designs.
 - Laser cutting apertures with trapezoidal walls and also rounding corners will offer better paste release. Customers should contact their board assembly site for stencil design recommendations. Refer to IPC-7525.
 - Customers should contact their board fabrication site for solder mask tolerances between and around signal pads.
 - This package is designed to be soldered to a thermal pad on the board. Refer to the Product Datasheet for specific thermal information, via requirements, and recommended thermal pad size. For thermal pad sizes larger than shown a solder mask defined pad is recommended in order to maintain the solderable pad geometry while increasing copper area.

IMPORTANT NOTICE AND DISCLAIMER

TI PROVIDES TECHNICAL AND RELIABILITY DATA (INCLUDING DATASHEETS), DESIGN RESOURCES (INCLUDING REFERENCE DESIGNS), APPLICATION OR OTHER DESIGN ADVICE, WEB TOOLS, SAFETY INFORMATION, AND OTHER RESOURCES "AS IS" AND WITH ALL FAULTS, AND DISCLAIMS ALL WARRANTIES, EXPRESS AND IMPLIED, INCLUDING WITHOUT LIMITATION ANY IMPLIED WARRANTIES OF MERCHANTABILITY, FITNESS FOR A PARTICULAR PURPOSE OR NON-INFRINGEMENT OF THIRD PARTY INTELLECTUAL PROPERTY RIGHTS.

These resources are intended for skilled developers designing with TI products. You are solely responsible for (1) selecting the appropriate TI products for your application, (2) designing, validating and testing your application, and (3) ensuring your application meets applicable standards, and any other safety, security, or other requirements. These resources are subject to change without notice. TI grants you permission to use these resources only for development of an application that uses the TI products described in the resource. Other reproduction and display of these resources is prohibited. No license is granted to any other TI intellectual property right or to any third party intellectual property right. TI disclaims responsibility for, and you will fully indemnify TI and its representatives against, any claims, damages, costs, losses, and liabilities arising out of your use of these resources.

TI's products are provided subject to TI's Terms of Sale (www.ti.com/legal/termsofsale.html) or other applicable terms available either on ti.com or provided in conjunction with such TI products. TI's provision of these resources does not expand or otherwise alter TI's applicable warranties or warranty disclaimers for TI products.

Mailing Address: Texas Instruments, Post Office Box 655303, Dallas, Texas 75265
Copyright © 2019, Texas Instruments Incorporated

Looking for pricing, stock, or lifecycle information?

Click below to explore more details on WIN SOURCE:

 [View TPS7A6050QKVURQ1 on WIN SOURCE](#)

 [Texas Instruments](#) Information

Optimize Your Supply Chain with WIN SOURCE Solutions

-  Global Sourcing Solution
-  Obsolete Management
-  Cost Control Management
-  Shortage Management
-  Alternative Solution
-  Excess Inventory Management