



**THE DATASHEET OF
SY898531LTZ-TR**





SY898531L

Precision Differential 3.3V Low-Skew LVPECL 1:9 Fanout Buffer

Precision Edge®

General Description

The SY898531L is a 3.3V, low-skew, 1:9 LVPECL fanout buffer with two selectable clock input pairs. Most standard differential input levels can be applied to the CLK, /CLK pair while LVPECL, CML, or SSTL input levels can be applied to the PCLK, /PCLK pair. To eliminate runt pulses on the outputs during asynchronous assertion/de-assertion of the clock enable pin, the clock enable is synchronized with the input signal.

The SY898531L operates from a 3.3V $\pm 5\%$ supply and is guaranteed over the full industrial temperature range of 0°C to +70°C. The SY898531L is part of Micrel's high-speed, Precision Edge® product line.

Datasheets and support documentation are available on Micrel's web site at: www.micrel.com.

Functional Block Diagram

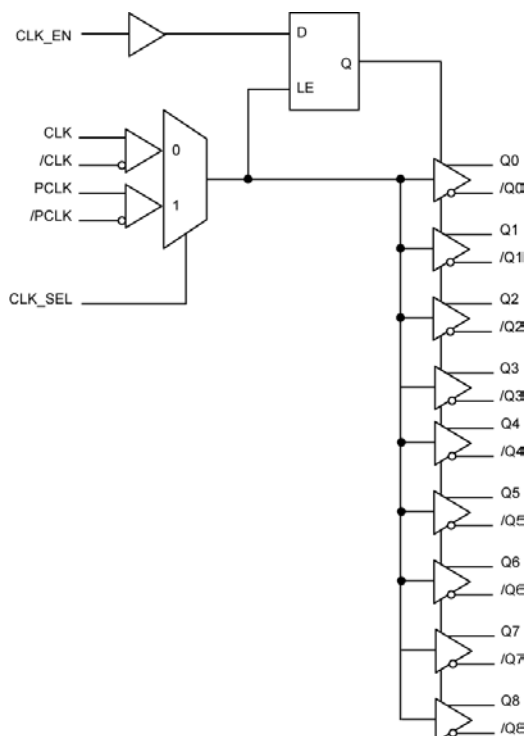

Precision Edge®

Features

- Provides nine differential 3.3V LVPECL copies
- Selects between differential CLK, /CLK or LVPECL clock inputs
- CLK, /CLK pair accepts LVDS, LVPECL, LVHSTL, SSTL, HCSL input levels
- PCLK, /PCLK pair accepts LVPECL, CML, SSTL input levels
- Guaranteed AC performance over temperature and supply voltage:
 - 500MHz maximum output frequency
 - < 2ns propagation delay (In-to-Q)
 - < 50ps output skew
 - < 250ps part-to-part skew
- Additive phase jitter, RMS: 0.17ps (typical)
- 3.3V $\pm 5\%$ supply voltage
- 0°C to +70°C temperature operating range
- Available in a 32-pin TQFP package

Applications

- SONET clock distribution
- Backplane distribution

Markets

- LAN/WAN
- Enterprise servers
- ATE
- Test and measurement

Precision Edge is a registered trademark of Micrel, Inc.

Micrel Inc. • 2180 Fortune Drive • San Jose, CA 95131 • USA • tel +1 (408) 944-0800 • fax + 1 (408) 474-1000 • <http://www.micrel.com>

June 25, 2013

Revision 2.0

hbwhelp@micrel.com or (408) 955-1690

Ordering Information

Part Number	Package Type	Operating Range ⁽¹⁾	Package Marking	Lead Finish
SY898531LTZ	T32-1	Commercial	SY898531LTZ with Pb-Free Bar-Line Indicator	Matte-Tin, Pb-Free
SY898531LTZTR ⁽²⁾	T32-1	Commercial	SY898531LTZ with Pb-Free Bar-Line Indicator	Matte-Tin, Pb-Free

Notes:

1. Contact factory for die availability. Dice are guaranteed at T_A = 25°C, DC electricals only.
2. Tape and Reel.

Pin Configuration

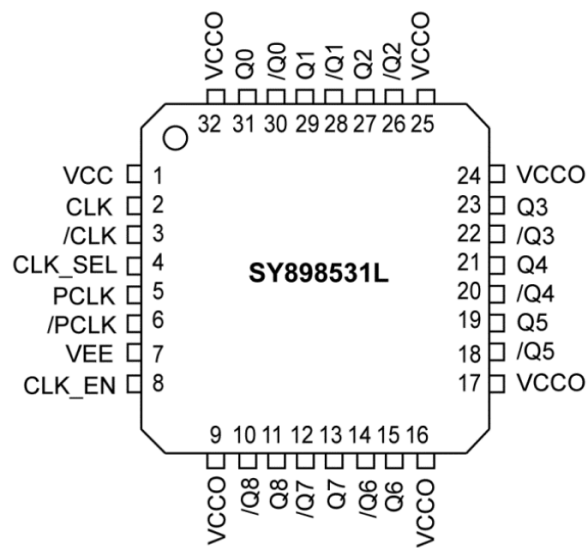

32-Pin 7mm x 7mm TQFP (T32-1)

Pin Description

Pin Number	Pin Name	Pin Function
7	V _{EE}	Ground.
8	CLK_EN	Single-Ended Input: This TTL/CMOS input disables and enables the Q0 – Q8 outputs. It is internally connected to a 50kΩ pull-up resistor and will default to a logic HIGH state if left open. When disabled, Q goes LOW and /Q goes HIGH. Since CLK_EN is synchronous with the input clock, the outputs will be enabled/disabled following a rising and a falling edge of the input clock. V _{TH} = is approximately 1.5V.
4	CLK_SEL	Single-Ended Input: This single-ended TTL/CMOS-compatible input selects the input to the multiplexer. Note that this input is internally connected to a 50kΩ pull-down resistor and will default to logic LOW state if left open. V _{TH} = is approximately 1.5V.
2, 3	CLK, /CLK	Differential Input: This input pair is a differential signal input to the device. This input accepts AC- or DC-coupled signals. CLK is internally connected to a 28kΩ pull-down resistor and will default to a logic LOW state if left open while /CLK is connected to a 50kΩ pull-up resistor and will default to a logic HIGH state if left open. This input pair is selected when CLK_SEL is set to logic LOW.
5, 6	PCLK, /PCLK	Differential Input: This input pair is a differential signal input to the device. This input accepts AC- or DC-coupled signals. PCLK is internally connected to a 50kΩ pull-down resistor and will default to a logic LOW state if left open while /PCLK is connected to a 50kΩ pull-up resistor and will default to a logic HIGH state if left open. This input pair is selected when CLK_SEL is set to logic HIGH.
1	V _{CC}	Positive Power Supply Pin: Bypass with 0.1μF 0.01μF low-ESR capacitor as close to the V _{CC} pin as possible.
9, 16, 17, 24, 25, 32	V _{CC0}	Output Positive Power Supply Pins: Bypass with 0.1μF 0.01μF low-ESR capacitors as close to the V _{CC0} pins as possible.
30, 31 28, 29 26, 27 22, 23 20, 21 18, 19 14, 15 12, 13 10, 11	Q0, /Q0 Q1, /Q1 Q2, /Q2 Q3, /Q3 Q4, /Q4 Q5, /Q5 Q6, /Q6 Q7, /Q7 Q8, /Q8	LVPECL Differential Output Pairs: Differential buffered output copies of the selected input signal. The output swing is typically 800mV. Unused output pairs may be left floating with no impact on jitter. These differential LVPECL outputs are a logic function of the CLK, /CLK and PCLK, /PCLK, and CLK_SEL inputs (see Truth Table).

Truth Table

Inputs			Outputs	
CLK_EN	CLK_SEL	Selected Source	Q0 :Q8	/Q0:/Q8
0	0	CLK, /CLK	Disabled : LOW	Disabled : HIGH
0	1	PCLK, /PCLK	Disabled : LOW	Disabled : HIGH
1	0	CLK, /CLK	CLK	/CLK
1	1	PCLK, /PCLK	PCLK	/PCLK

Absolute Maximum Ratings⁽³⁾

Supply Voltage (V_{CC}) -0.5V to +4.6V
 Input Voltage (V_{IN}) -0.5V to $V_{CC} + 0.5V$
 LVPECL Output Current (I_{OUT})
 Continuous 50mA
 Surge 100mA
 Lead Temperature (soldering, 20s) +260°C
 Storage Temperature (T_s) -65°C to 150°C

Operating Ratings⁽⁴⁾

Supply Voltage (V_{CC}) +3.135V to +3.465V
 Ambient Temperature (T_A) 0°C to +70°C
 Package Thermal Resistance⁽⁵⁾
 TSSOP (θ_{JA})
 Still-Air 50°C/W

Power Supply DC Electrical Characteristics⁽⁶⁾

$V_{CC} = V_{CCO} = 3.3V \pm 5\%$; $T_A = 0^\circ C$ to +70°C, unless otherwise stated.

Symbol	Parameter	Condition	Min.	Typ.	Max.	Units
V_{CC}	Power Supply		3.135	3.3	3.465	V
V_{CCO}	Output Power Supply		3.135	3.3	3.465	V
I_{EE}	Power Supply Current	No load, maximum V_{CC}			80	mA

LVC MOS/LVTTL DC Electrical Characteristics⁽⁶⁾

$V_{CC} = V_{CCO} = 3.3V \pm 5\%$; $T_A = 0^\circ C$ to +70°C, unless otherwise stated.

Symbol	Parameter	Condition	Min.	Typ.	Max.	Units
V_{IH}	Input High Voltage		2		$V_{CC} + 0.3$	V
V_{IL}	Input Low Voltage		-0.3		0.8	V
I_{IH}	Input High Current	CLK_EN $V_{IN} = V_{CC} = 3.465V$			5	μA
		CLK_SEL $V_{IN} = V_{CC} = 3.465V$			150	
I_{IL}	Input Low Current	CLK_EN $V_{IN} = 0V, V_{CC} = 3.465V$	-150			μA
		CLK_SEL $V_{IN} = 0V, V_{CC} = 3.465V$	-5			

Notes:

- Permanent device damage may occur if absolute maximum ratings are exceeded. This is a stress rating only and functional operation is not implied at conditions other than those detailed in the operational sections of this data sheet. Exposure to absolute maximum rating conditions for extended periods may affect device reliability.
- The data sheet limits are not guaranteed if the device is operated beyond the operating ratings.
- θ_{JA} value is determined for a 4-layer board in still air unless otherwise stated.
- The circuit is designed to meet the DC specifications shown in the above table after thermal equilibrium has been established.

Differential DC Electrical Characteristics⁽⁶⁾

$V_{CC} = V_{CCO} = 3.3V \pm 5\%$; $T_A = 0^\circ C$ to $+70^\circ C$, unless otherwise stated.

Symbol	Parameter	Condition	Min.	Typ.	Max.	Units
I_{IH}	Input High Current	CLK $V_{IN} = V_{CC} = 3.465V$			150	μA
		/CLK $V_{IN} = V_{CC} = 3.465V$			5	
I_{IL}	Input Low Current	CLK $V_{IN} = 0.5V, V_{CC} = 3.465V$	-5			μA
		/CLK $V_{IN} = 0.5V, V_{CC} = 3.465V$	-150			
V_{PP}	Peak-to-Peak Input Voltage		0.15		1.3	V
V_{CMR}	Common Mode Input Voltage ^(7, 8)		$V_{EE} + 0.5$		$V_{CC} - 0.85$	V

LVPECL DC Electrical Characteristics⁽⁹⁾

$V_{CC} = V_{CCO} = 3.3V \pm 5\%$; $T_A = 0^\circ C$ to $+70^\circ C$, unless otherwise stated

Symbol	Parameter	Condition	Min.	Typ.	Max.	Units
I_{IH}	Input High Current	PCLK $V_{IN} = V_{CC} = 3.465V$			150	μA
		/PCLK $V_{IN} = V_{CC} = 3.465V$			5	
I_{IL}	Input Low Current	PCLK $V_{IN} = 0V, V_{CC} = 3.465V$	-5			μA
		/PCLK $V_{IN} = 0V, V_{CC} = 3.465V$	-150			
V_{PP}	Peak-to-Peak Input Voltage		0.3		1	V
V_{CMR}	Common Mode Input Voltage ^(10, 11)		$V_{EE} + 1.5$		V_{CC}	V
V_{OH}	Output High Voltage ⁽¹²⁾		$V_{CC} - 1.4$		$V_{CC} - 1.0$	V
V_{OL}	Output Low Voltage ⁽¹²⁾		$V_{CC} - 2.0$		$V_{CC} - 1.7$	V
V_{SWING}	Peak-to-Peak Output Voltage Swing		0.6		1.0	V

Notes:

7. Maximum input voltage for CLK and /CLK is $V_{CC} + 0.3V$ for single-ended applications.
8. V_{IH} is defined as the common-mode voltage.
9. The circuit is designed to meet the DC specifications shown in the above table after thermal equilibrium has been established.
10. Maximum input voltage for PCLK and /PCLK is $V_{CC} + 0.3V$ for single-ended applications.
11. V_{IH} is defined as the common-mode voltage.
12. 50Ω to $V_{CCO} - 2V$ terminated outputs.

AC Electrical Characteristics⁽¹³⁾

$V_{CC} = V_{CC0} = 3.3V \pm 5\%$; $R_L = 50\Omega$ to $V_{CC0} - 2V$; $T_A = 0^\circ C$ to $+70^\circ C$, unless otherwise stated.

Symbol	Parameter	Condition	Min.	Typ.	Max.	Units
f_{MAX}	Maximum Operating Frequency		500			MHz
t_{PD}	Differential Propagation Delay CLK-to-Q, PCLK-to-Q	$f \leq 250MHz$	1		2	ns
t_{SKEW}	Output-to-Output Skew ⁽¹⁴⁾				50	ps
	Part-to-Part Skew ⁽¹⁵⁾				250	ps
t_{JITTER}	Additive Phase Jitter ⁽¹⁶⁾	155.52MHz, (12KHz to 20MHz)		0.17		psRMS
t_r, t_f	Output Rise/Fall Time	20% to 80% @ 50MHz	300		700	ps
odc	Output Duty Cycle		48	50	52	%

Note:

13. High-frequency AC-parameters are guaranteed by design and characterization.
14. Output-to-output skew is measured between two different outputs under identical transitions.
15. Part-to-part skew is defined for two parts with identical power supply voltages at the same temperature and with no skew of the edges at the respective inputs. This parameter is defined in accordance with JEDEC Standard 65.
16. Driving only one input clock.

Timing Diagrams

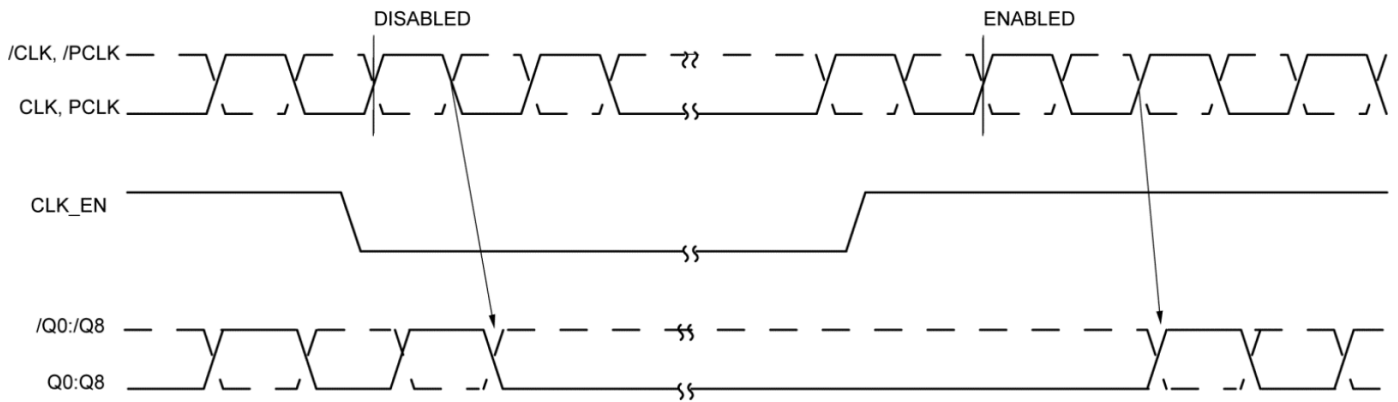

Figure 1. CLK_EN Timing Diagram

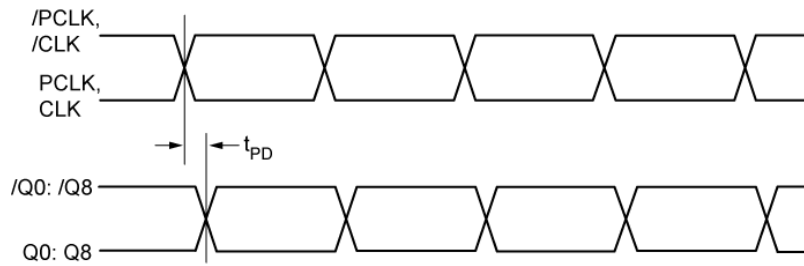

Figure 2. Propagation Delay

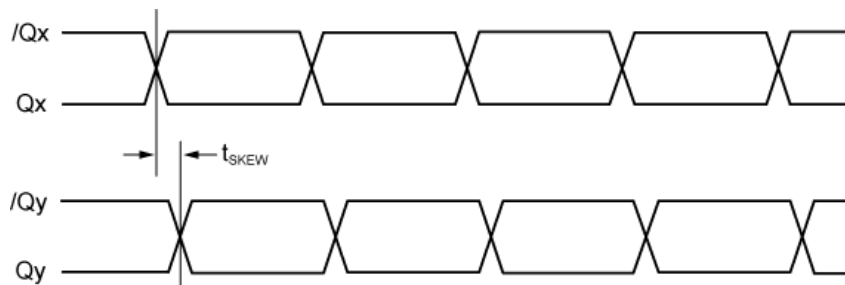
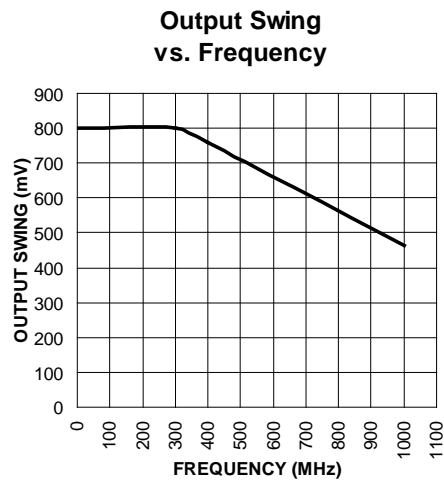

Figure 3. Output-to-Output Skew

Typical Operating Characteristics

$V_{CC} = 3.3V$, $V_{EE} = 0V$, $V_{IN} = 800mV$, $R_L = 50\Omega$ to $V_{CC} - 2V$; $T_A = 25^\circ C$, unless otherwise stated.



Functional Characteristics

$V_{CC} = 3.3V$, $V_{EE} = 0V$, $V_{IN} = 800mV$, $R_L = 50\Omega$ to $V_{CC} - 2V$; $T_A = 25^\circ C$, unless otherwise stated.

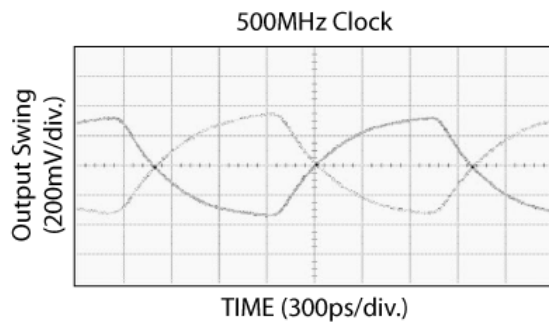
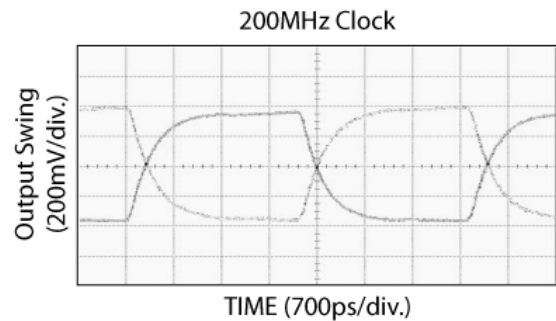
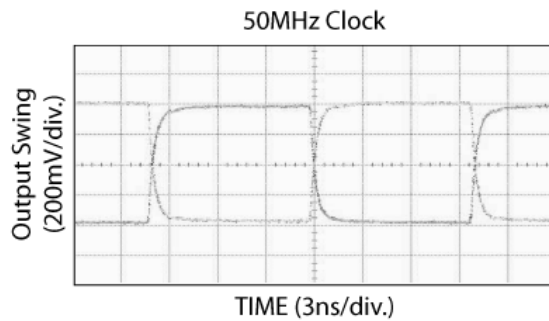

CLK, /CLK Input Interface Applications

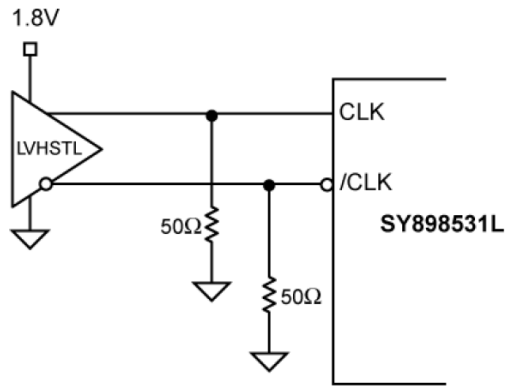

Figure 4. LVHSTL Interface (DC-Coupled)

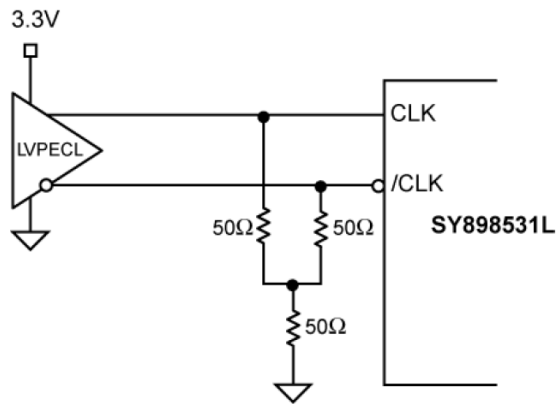

Figure 5. LVPECL Interface (DC-Coupled)

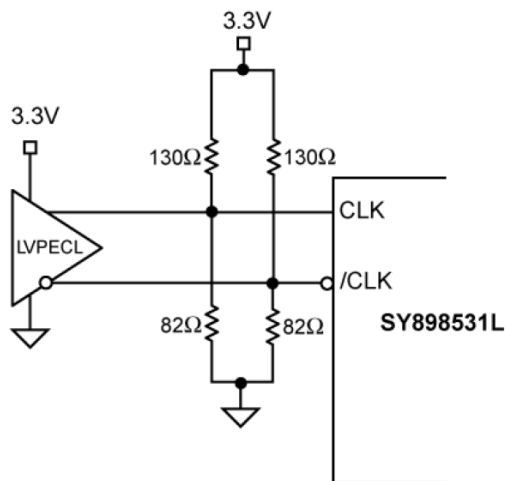

Figure 6. LVPECL Interface (DC-Coupled)

CLK, /CLK Input Interface Applications (Continued)

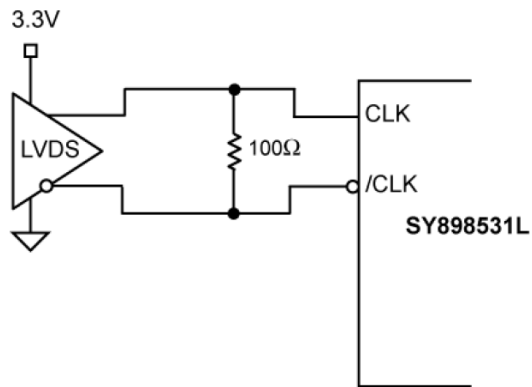

Figure 7. LVDS Interface (DC-Coupled)

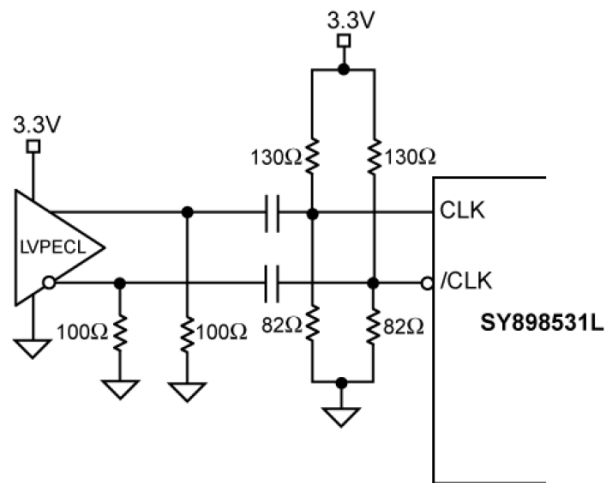

Figure 8. LVPECL Interface (AC-Coupled)

PCLK, /PCLK Input Interface Applications

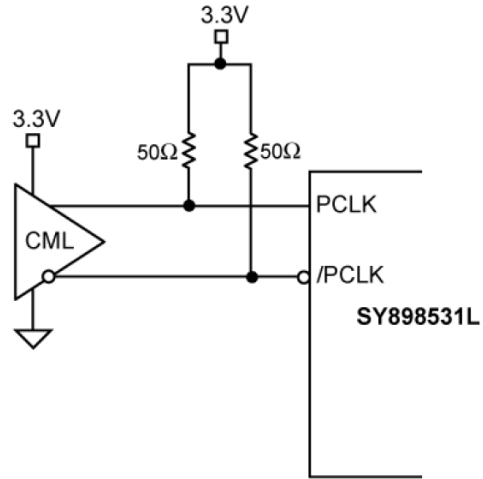

Figure 9. CML Open Collector Interface (DC-Coupled)

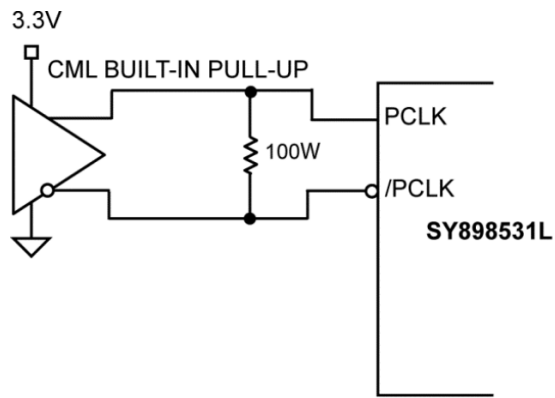

Figure 10. CML Built-In Pull-Up Interface (DC-Coupled)

PCLK, /PCLK Input Interface Applications (Continued)

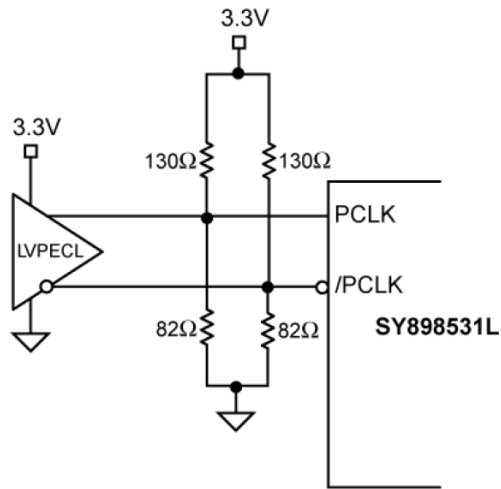

Figure 11. LVPECL Interface (DC-Coupled)

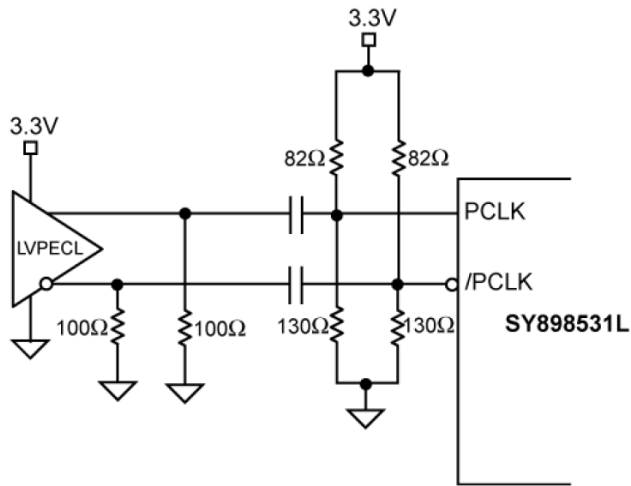

Figure 12. LVPECL Interface (AC-Coupled)

PCLK, /PCLK Input Interface Applications (Continued)

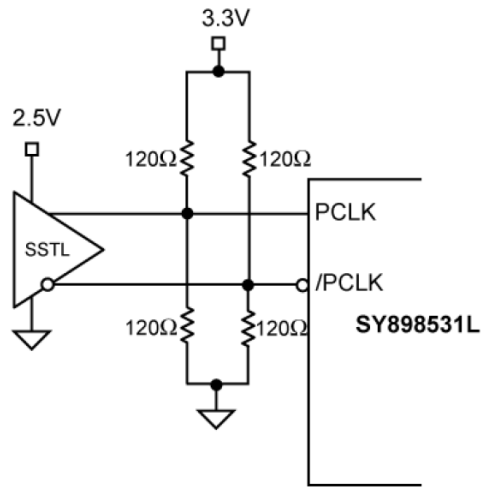

Figure 13. SSTL Interface (DC-Coupled)

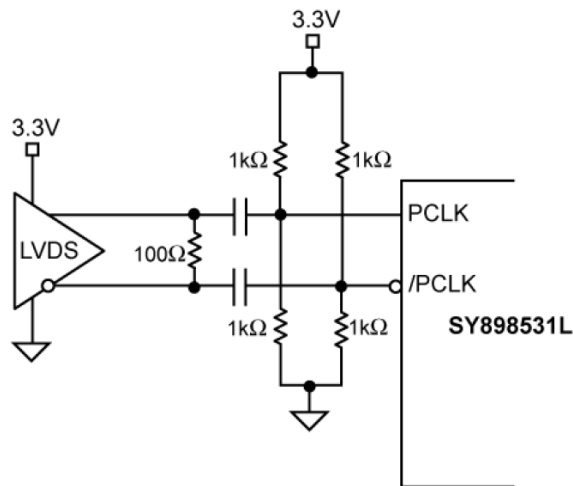
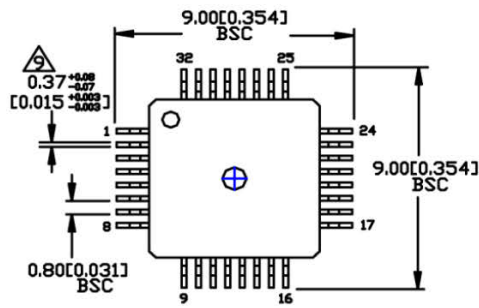
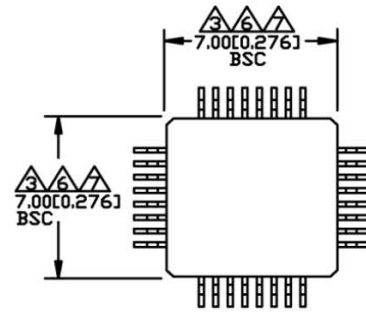

Figure 14. LVDS Interface (AC-Coupled)

Package Information⁽¹⁷⁾



TOP VIEW



BOTTOM VIEW

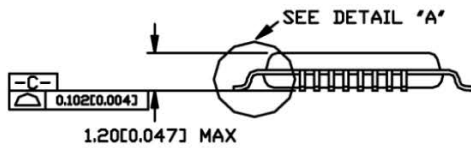

SIDE VIEW

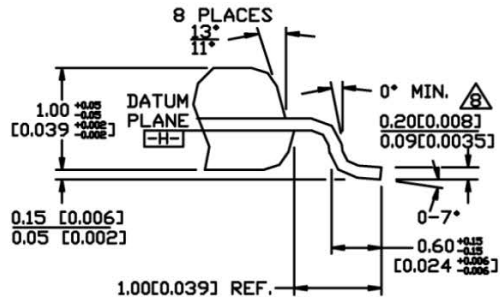

DETAIL "A"

- NOTES:**
1. DIMENSIONS ARE IN MM(INCHES).
 2. CONTROLLING DIMENSION: MM.
 3. DIMENSION DOES NOT INCLUDE MOLD FLASH OR PROTRUSIONS, EITHER OF WHICH SHALL NOT EXCEED 0.254 [0.010].
 4. LEAD DIMENSION DOES NOT INCLUDE DAMBAR PROTRUSION.
 5. MAXIMUM AND MINIMUM SPECIFICATIONS ARE INDICATED AS FOLLOWS: MAX/MIN.
- △ THESE DIMENSIONS TO BE DETERMINED AT DATUM PLANE
- △ PACKAGE TOP DIMENSIONS ARE SMALLER THAN BOTTOM DIMENSIONS AND TOP OF PACKAGE WILL NOT OVERHANG BOTTOM OF PACKAGE.
- △ DIMENSION INCLUDES LEAD FINISH.

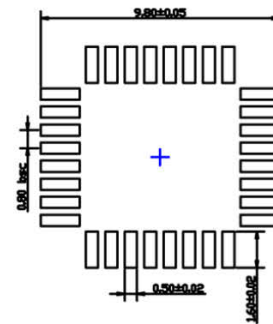

RECOMMENDED LAND PATTERN

32-Pin 7mm x 7mm TQFP (T32-1)

Note:

17. Package information is correct as of the publication date. For updates and most current information, go to www.micrel.com.

MICREL, INC. 2180 FORTUNE DRIVE SAN JOSE, CA 95131 USA
TEL +1 (408) 944-0800 FAX +1 (408) 474-1000 WEB <http://www.micrel.com>

Micrel makes no representations or warranties with respect to the accuracy or completeness of the information furnished in this data sheet. This information is not intended as a warranty and Micrel does not assume responsibility for its use. Micrel reserves the right to change circuitry, specifications and descriptions at any time without notice. No license, whether express, implied, arising by estoppel or otherwise, to any intellectual property rights is granted by this document. Except as provided in Micrel's terms and conditions of sale for such products, Micrel assumes no liability whatsoever, and Micrel disclaims any express or implied warranty relating to the sale and/or use of Micrel products including liability or warranties relating to fitness for a particular purpose, merchantability, or infringement of any patent, copyright or other intellectual property right.

Micrel Products are not designed or authorized for use as components in life support appliances, devices or systems where malfunction of a product can reasonably be expected to result in personal injury. Life support devices or systems are devices or systems that (a) are intended for surgical implant into the body or (b) support or sustain life, and whose failure to perform can be reasonably expected to result in a significant injury to the user. A Purchaser's use or sale of Micrel Products for use in life support appliances, devices or systems is a Purchaser's own risk and Purchaser agrees to fully indemnify Micrel for any damages resulting from such use or sale.

© 2009 Micrel, Incorporated.

Looking for pricing, stock, or lifecycle information?

Click below to explore more details on WIN SOURCE:

- ⊖ [View SY898531LTZ-TR on WIN SOURCE](#)
- ⊖ [Microchip Technology](#) Information

Optimize Your Supply Chain with WIN SOURCE Solutions

- ✓ Global Sourcing Solution
- ✓ Obsolete Management
- ✓ Cost Control Management
- ✓ Shortage Management
- ✓ Alternative Solution
- ✓ Excess Inventory Management