

**VIN = 5 to 25 V, 1-channel DC-DC Step down Regulator
integrated N-channel Power MOSFET for USB**

FEATURES

- 1-channel DC-DC Step Down Regulator Circuit that employs Voltage Mode Switching Control System
- Current Feedback Function compensates output voltage drop due to external USB cable loss
- Internal reference voltage is within $\pm 1.5\%$ accuracy
- Input Voltage Range : PVCC , VCC: 5 V ~ 25 V
- Adjustable Switching Frequency with external Resistor : 200 kHz ~ 1 MHz
- Adjustable Output Voltage Range with external Resistor : 1.2 V ~ 9 V
- Standby mode consumes less than 1 μ A current
- Output over voltage protection function
- Output ground short protection function
- Over current protection with adjustable threshold.
- Thermal Shut Down (TSD)
- Under voltage lockout function (UVLO)
- Thermal Shut Down function
- Adjustable soft-start function
- SSOP024-P-0300F
(Size : 8.1 mm X 7.8 mm, 0.65 mm pitch),
24pin Plastic Shrink Small Outline Package (SSOP Type)

DESCRIPTION

AN33014UA is 1-channel DC-DC Step down Regulator integrated N-channel Power MOSFET and employs the voltage mode switching control system.

This IC can be operated with wide input voltage range and is build in several protection functions, so this IC can provide high reliability power supply system.

Since it is possible to use up to 1 MHz switching frequency and it is unnecessary to add external parts for High Side Switch, this IC realizes downsizing of set and reducing in the number of external parts.

For USB applications, this IC can controlled USB supplied voltage level with external resistor for USB load current monitor (Current Feedback Function), and it can provide suitable power supply system for external USB with no voltage drop due to USB cable loss.

Maximum current is 1.5 A.

APPLICATIONS

- High Input Voltage Power Systems for USB such as
- Car-Audio system
 - Car-Navigation system
 - OA Equipment
 - Home Appliances etc.

SIMPLIFIED APPLICATION

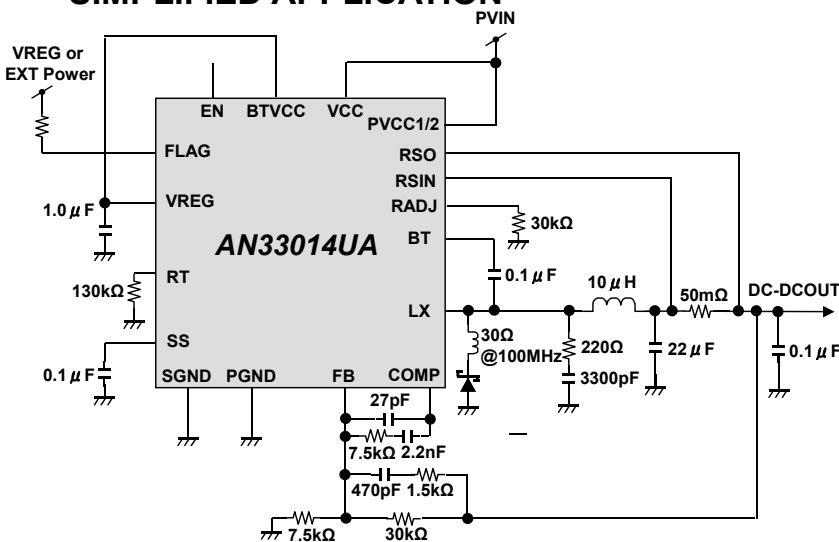

Notes) This application circuit is an example. The operation of mass production set is not guaranteed. You should perform enough evaluation and verification on the design of mass production set. You are fully responsible for the incorporation of the above application circuit and information in the design of your equipment.

EFFICIENCY CURVE

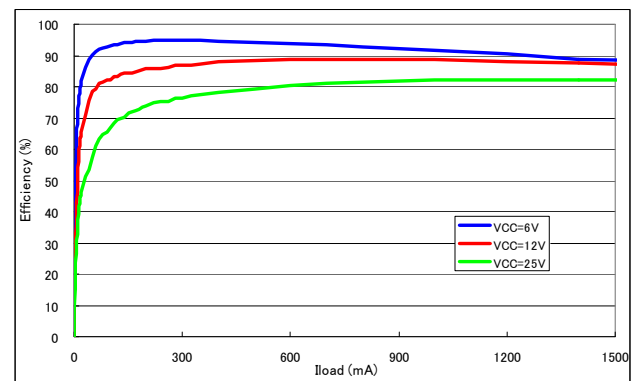

Condition)
Vin = 6 , 12 , 25 V, Vout = 5 V,
Lo = 10 μ H, Co = 22 μ F, Frequency = 490 kHz
RSENSE=50m Ω

ABSOLUTE MAXIMUM RATINGS

Parameter	Symbol	Rating	Unit	Notes
Supply voltage	V _{CC}	40	V	*1
Operating free-air temperature	T _{opr}	- 40 to + 85	°C	*2
Operating junction temperature	T _j	- 40 to + 150	°C	*2
Storage temperature	T _{stg}	- 55 to + 150	°C	*2
Input Voltage Range	V _{BT}	-0.3 to (V _{CC} +V _{REG})	V	*1 *3
	V _{RSIN} , V _{RSO}	-0.3 to 10	V	*1
	V _{EN}	-0.3 to (V _{CC} +0.3)	V	*1 *4
	V _{FB} , V _{BTVCC} , V _{SYNC}	-0.3 to 5.5	V	*1
Output Voltage Range	V _{FLAG}	-0.3 to 5.5	V	*1
	V _{LX}	- 0.3 to (V _{CC} + 0.3)	V	*1 *4
ESD	V _{HBM} (Human Body Model)	2	kV	—
	V _{MM} (Machine Model)	200	V	—

Notes) Do not apply external currents and voltages to any pin not specifically mentioned.

This product may sustain permanent damage if subjected to conditions higher than the above stated absolute maximum rating. This rating is the maximum rating and device operating at this range is not guaranteeable as it is higher than our stated recommended operating range. When subjected under the absolute maximum rating for a long time, the reliability of the product may be affected.

V_{CC} is voltage for V_{CC}, PV_{CC1} and PV_{CC2}. V_{CC} = PV_{CC1} = PV_{CC2}.

*1:The values under the condition not exceeding the above absolute maximum ratings and the power dissipation.

*2:Except for the power dissipation, operating ambient temperature, and storage temperature, all ratings are for Ta = 25 °C.

*3:(V_{CC} + V_{REG}) V must not be exceeded 40 V

*4:(V_{CC} + 0.3) V must not be exceeded 40 V

POWER DISSIPATION RATING

PACKAGE	θ _{j-a}	θ _{j-C}	PD (Ta = 25 °C)	PD (Ta = 85 °C)	Notes
24 Pin Plastic Shrink Small Outline Package (SSOP Type)	135.1 °C / W	11.8 °C / W	0.925 W	0.481 W	*1

Note). For the actual usage, please refer to the PD-Ta characteristics diagram in the package specification, follow the power supply voltage, load and ambient temperature conditions to ensure that there is enough margin and the thermal design does not exceed the allowable value.

*1:Glass Epoxy Substrate(4 Layers) [Glass-Epoxy: 50 X 50 X 0.8t(mm)]



CAUTION

Although this has limited built-in ESD protection circuit, but permanent damage may occur on it. Therefore, proper ESD precautions are recommended to avoid electrostatic damage to the MOS gates

RECOMMENDED OPERATING CONDITIONS

Parameter	Pin Name	Min.	Typ.	Max.	Unit	Notes
Supply voltage range	V_{CC}	5	12	25	V	*1
	PV_{CC1}					
	PV_{CC2}					
Input Voltage Range	V_{BT}	-0.3	—	$V_{CC} + V_{REG}$	V	*1 *2
	V_{RSIN}	-0.3	—	10	V	*1
	V_{RSO}					
	V_{EN}	-0.3	—	$V_{CC} + 0.3$	V	*1 *3
	V_{FB}	-0.3	—	5.5	V	*1
	V_{BTVCC}					
	V_{SYNC}					
Output Voltage Range	V_{LX}	-0.3	—	$V_{CC} + 0.3$	V	*1 *3
	V_{FLAG}	-0.3	—	5.5	V	*1

Note) Do not apply external currents and voltages to any pin not specifically mentioned.

Voltage values, unless otherwise specified, are with respect to GND. GND is voltage for SGND, PGND. SGND = PGND
 V_{CC} is voltage for V_{CC} , PV_{CC1} and PV_{CC2} . $V_{CC} = PV_{CC1} = PV_{CC2}$.

*1 : The values under the condition not exceeding the above absolute maximum ratings and the power dissipation.

*2 : ($V_{CC} + V_{REG}$) V must not be exceeded 40 V

*3 : ($V_{CC} + 0.3$) V must not be exceeded 40 V

ELECTRICAL CHARACTERISTICS

Co = 22 μF, Lo = 10 μH, VOUT Setting = 5.0 V, VCC = 12 V, RT = 130 kΩ, RADJ = 30 kΩ, Rsense = 50 mΩ,
RS2 : MPZ1608S300A, Ta = 25 °C ± 2 °C unless otherwise noted.

Parameter	Symbol	Condition	Limits			Unit	Note
			Min	Typ	Max		
Current Consumption							
Quiescent current	ICQ	No switching FB = 1.1 V EN = High (3.3 V)	—	1.0	1.7	mA	—
Standby current	I _{STBY}	EN = Low	—	0.01	1	μA	—
BGR							
Feedback voltage	V _{REF}	FB connected to COMP with gain of 1.5 times	0.985	1.0	1.015	V	—
Enable (EN)							
Low input threshold	V _{IL1}	—	—	—	0.4	V	—
High input threshold	V _{IH1}	—	2.0	—	—	V	—
EN terminal input current	V _{IC1}	EN = 3.3 V	—	33	70	μA	—
SYNCHRONIZATION (SYNC)							
Low input threshold	V _{IL2}	—	—	—	0.4	V	—
High input threshold	V _{IH2}	—	2.0	—	—	V	—
Oscillator							
Oscillator frequency	F _{OUT1}	RT = 130 kΩ	440	490	540	kHz	—
Oscillator frequency range	F _{OUT2}		200	—	1000	kHz	—
External sync frequency range	F _{SYNC}	RT = 130 kΩ F _{OUT1} = 490 kHz	545	—	730	kHz	—
Over-current protection							
Over-current threshold voltage	V _{OCV}	(VCC_S-VRS)	72	90	108	mV	*1
Over-voltage protection							
Over-voltage threshold voltage for VFB	V _{OV1}	For FB	1.14	1.22	1.30	V	—
Over-voltage threshold voltage for VCC	V _{OV2}	For VCC	30	34	38	V	—
Internal regulator							
Internal regulator output voltage	V _{REG}	C _{REG} = 1 μF	4.5	5.0	5.3	V	—
GND short protection							
Short detection voltage	V _{SCP}	monitor FB	0.15	0.3	0.45	V	—

Note) *1 : This parameter is tested with DC measurement.

ELECTRICAL CHARACTERISTICS (Continued)

Co = 22 μF, Lo = 10 μH, VOUT Setting = 5.0 V, VCC = 12 V, RT = 130 kΩ, RADJ = 30 kΩ, Rsense = 50 mΩ,
Ta = 25 °C ± 2 °C unless otherwise noted.

Parameter	Symbol	Condition	Limits			Unit	Note
			Min	Typ	Max		
Current Feedback							
Current feedback output voltage 1	V _{CFB1}	Monitor RADJ At RSIN-RSO = 32.5 mV No switching	75	130	185	mV	*1
Current feedback output voltage 2	V _{CFB2}	Monitor RADJ At RSIN-RSO = 65 mV No switching	205	260	315	mV	*1
Current feedback factor	V _{CFBF}	Calculation item (V _{CFB2} - V _{CFB1}) / {4 x (65 mV - 32.5 mV)}	0.96	1	1.04	—	—
Under voltage Lock out							
Under Voltage Lock Out threshold voltage	V _{UVLO}	Monitor VCC No switching	3.5	3.9	4.3	V	—

Note) *1 : This parameter is tested with DC measurement.

PIN CONFIGURATION

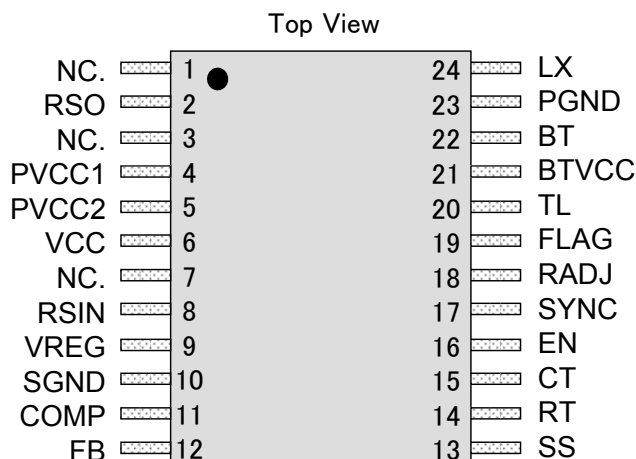

PIN FUNCTIONS

Pin No.	Pin name	Type	Description
1	N.C.	—	No connection
2	RSO	Input	Connection to current sensing port
3	N.C.	—	No connection
4	PVCC1	Power Supply	Power supply pin for internal driver
5	PVCC2	Power Supply	Power supply pin for internal driver
6	VCC	Power Supply	Power supply pin
7	N.C.	—	No connection
8	RSIN	Input	Connection to current sensing port
9	VREG	Output	Connect to an external capacitor for internal regulator
10	SGND	Ground	Ground pin
11	COMP	Output	Error amplifier output
12	FB	Input	Error amplifier negative input
13	SS	Output	Soft-start capacitor connection pin
14	RT	Output	Connect to an external resistor for adjustment of oscillation frequency
15	CT	Output	Low Pass filter function pin for PLL
16	EN	Input	Enable pin
17	SYNC	Input	External clock input for adjustment of oscillation frequency
18	RADJ	Output	Connect to an external resistor for adjustment of current feedback
19	FLAG	Output	Error flag output pin
20	TL	Output	Connect to an external capacitor for adjustment of over-current detection time
21	BTVCC	Input	Boot strap input pin
22	BT	Input	Connect to an external capacitor for Boot strap
23	PGND	Ground	Power ground pin
24	LX	Output	Connect to an external inductor and schottky diode

Notes) Concerning detail about pin description, please refer to OPERATION and APPLICATION INFORMATION section.

FUNCTIONAL BLOCK DIAGRAM

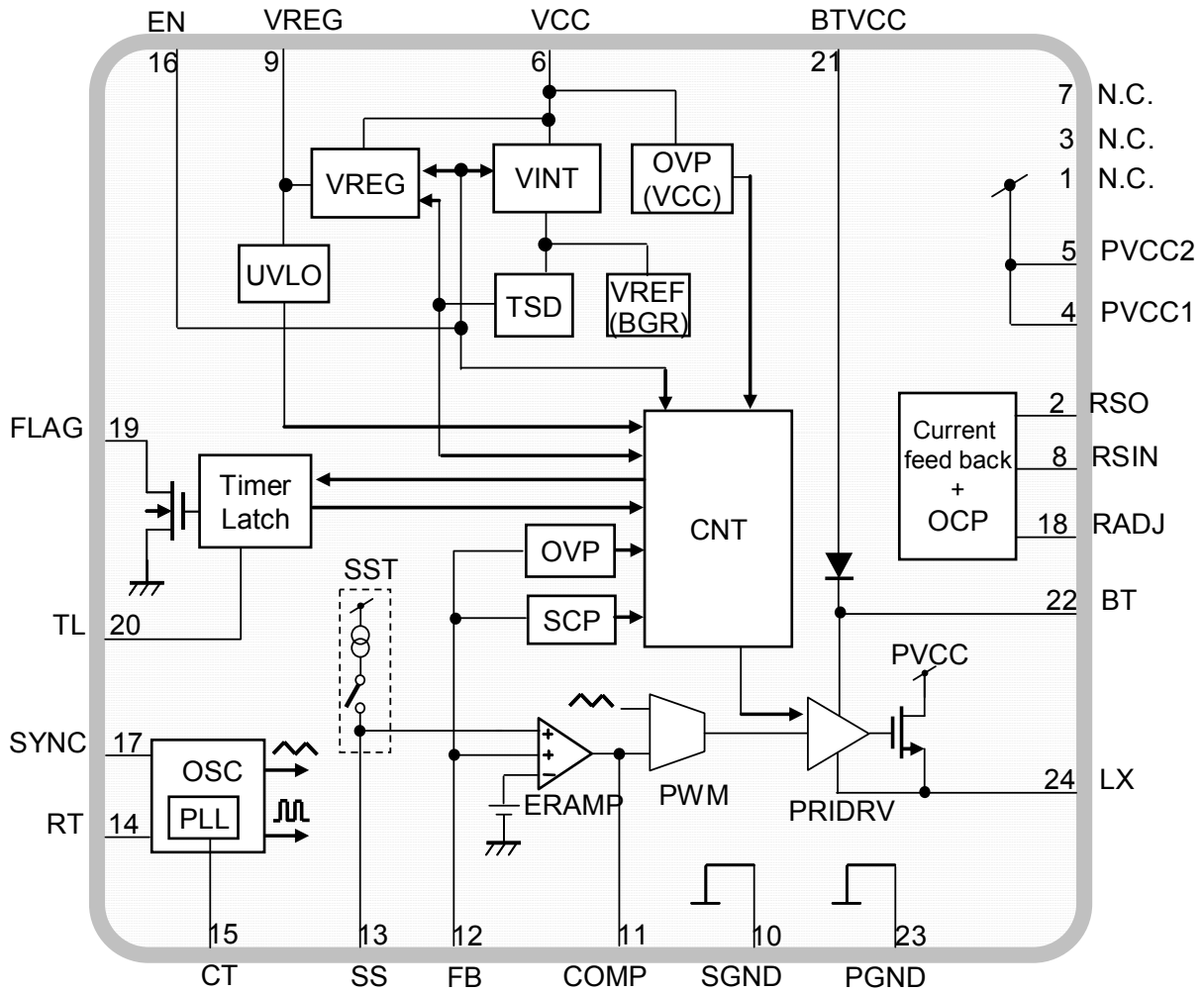

Notes) This block diagram is for explaining functions. Part of the block diagram may be omitted, or it may be simplified.

OPERATION

1. Power ON/OFF sequence

Note) The characteristics listed below are reference values derived from the design of the IC and are not guaranteed.

AN33014UA consists of one channel and it can be turned ON and OFF by using the EN pin.

EN > 2.0 V : Enabled
EN < 0.4 V : Disabled

1) Power ON Sequence :

- VCC rises to a desired voltage level.
(A 10 μ s rise time or more is recommended to control and limit any abnormal current flow via the power transistor when VCC is rising.)
- Apply a voltage level of 2.0 V or higher at EN pin after VCC is steady, and the DC-DC will begin to operate. (It is possible to connect the EN pin to VCC through a resistor, and, in that case, when VCC rises, DC-DC will begin to operate.)
- When VREG voltage reaches 4.3 V and above, and after a delay time (charging time of the soft start capacitor) decided by an external capacitor, the DC-DC will start to operate.

2) Power OFF Sequence :

- To turn OFF the DC-DC output, apply a voltage of 0.4 V or lower to EN pin.
- VOUT will drop after EN pin becomes Low.
(The discharge time is dependent on the applied load current and the feedback resistance connected at the output.)
- The DC-DC will turn OFF if the VCC level becomes low even before EN pin becomes low.
The above scenario occurs when the VREG voltage decreases to 4.0 V or less.
(However, the DC-DC output voltage will also decrease with VCC when the VCC level drops below a certain minimum level required to maintain the output voltage level.)

3) Points to take note of when re-starting the DC-DC :

- Please allow a waiting time of 10 ms or more for the discharge time of the soft start capacitor when starting up the DC-DC again after turning it OFF.
The output voltage might overshoot without the soft start function working properly if the DC-DC is re-started immediately after it is turned OFF.

4) Points to take note of when shut down :

- Please turn OFF the DC-DC by applying a Low voltage of EN pin.

5) Points to take note of pin connection :

- VREG is utilized for internal circuits. do not use it as power supply for other device.
- Please take note on the placement of external parts of RT pin and CT pin as these are sensitive pin that are susceptible to noise effect such as LX pin.

OPERATION (Continued)

2. Start / Stop Control Timing Chart

Note) The characteristics listed below are reference values derived from the design of the IC and are not guaranteed.

- ON/OFF operation sequence by EN pin control.

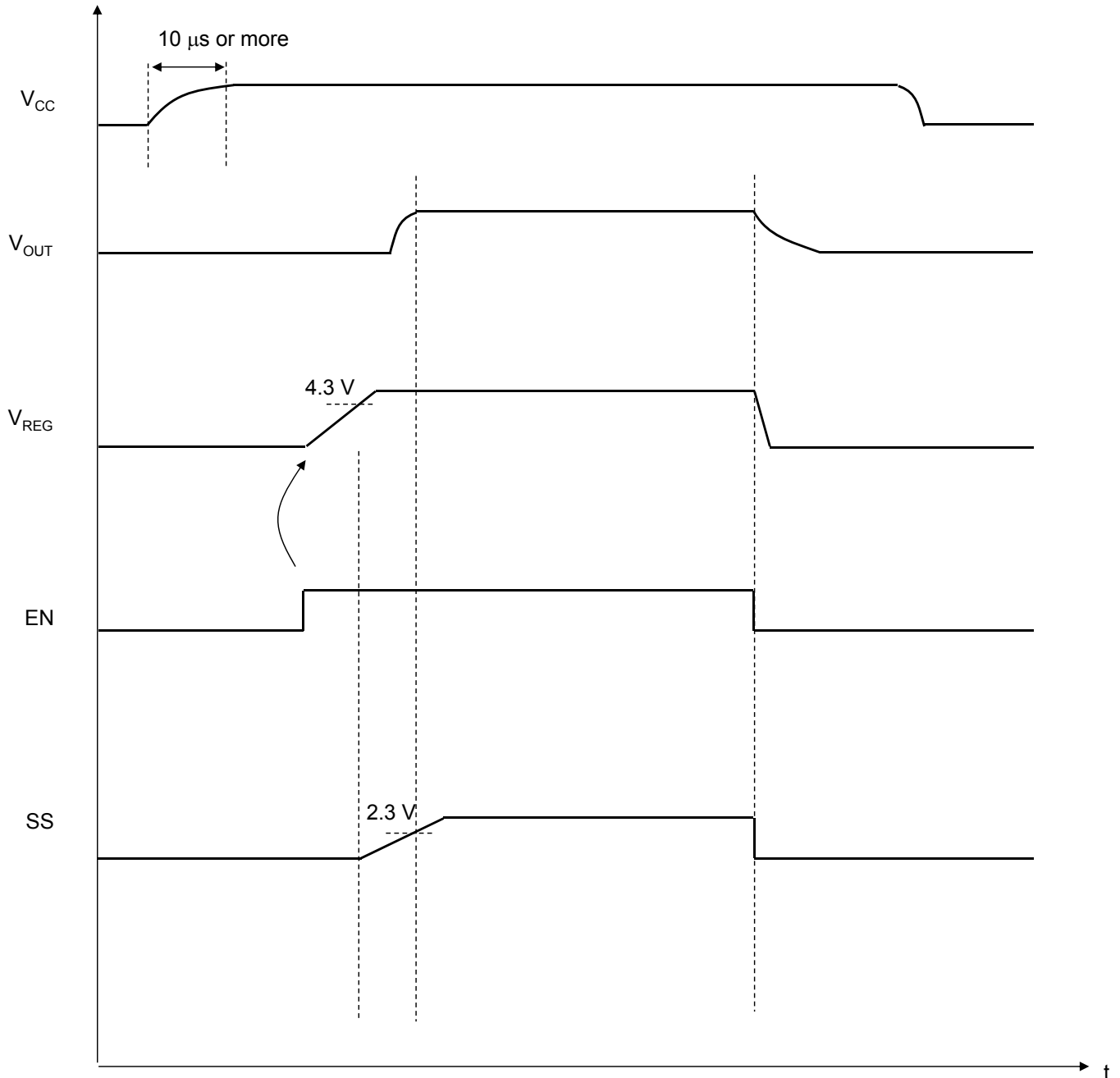

Figure : Power ON/OFF sequence by EN

Note) All values given in the above figure are typical values.

OPERATION (Continued)

2. Start / Stop Control Timing Chart

Note) The characteristics listed below are reference values derived from the design of the IC and are not guaranteed.

- ON/OFF operation sequence by VCC pin control (EN pin is connected to VCC).

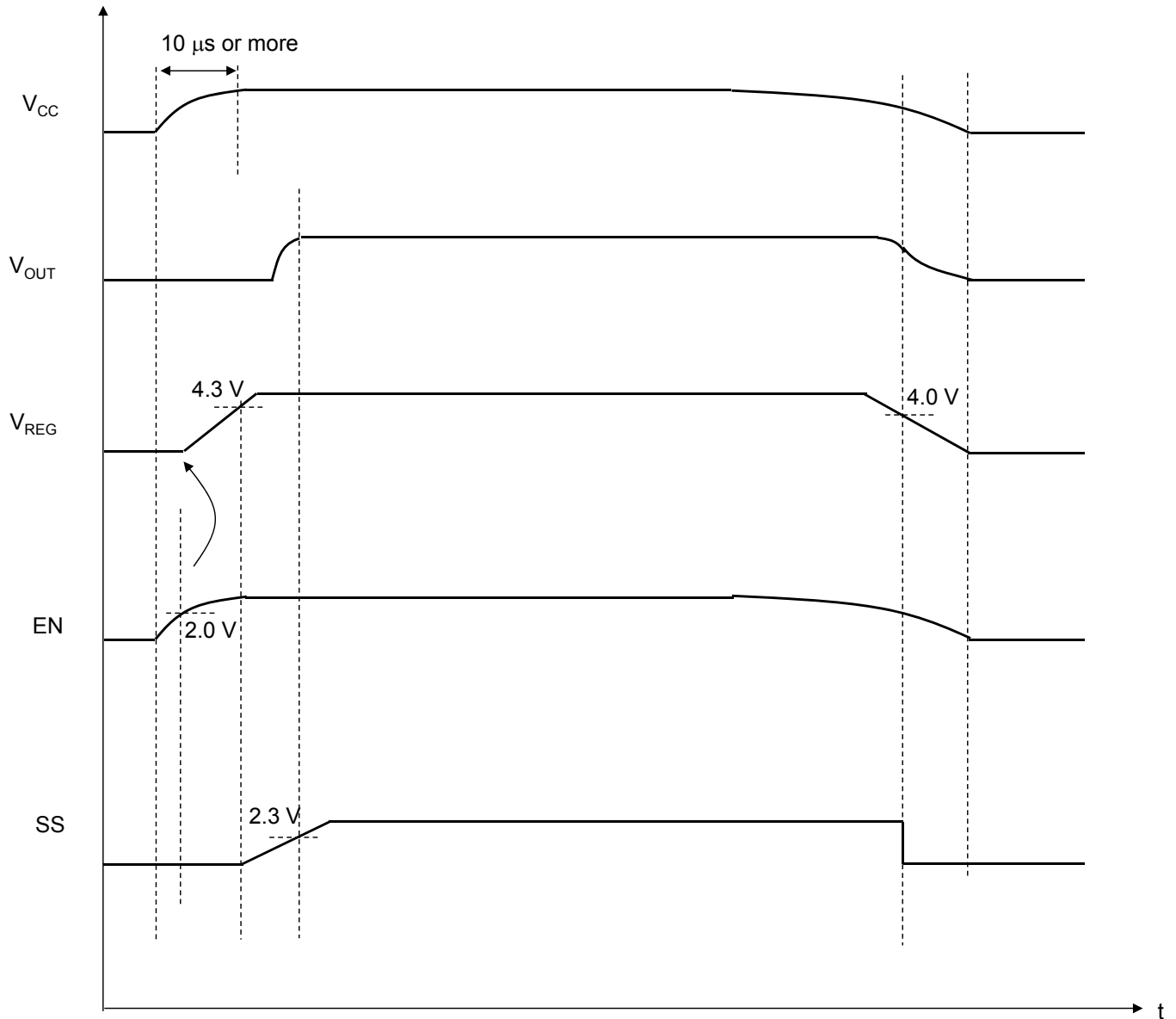

Figure : Power ON/OFF sequence by VCC/EN

Note) All values given in the above figure are typical values.

OPERATION (Continued)

3. Output voltage setting

Note) The characteristics listed below are reference values derived from the design of the IC and are not guaranteed.

The output voltage of AN33014UA is set with the external feedback resistance divider arranged between the terminal FB and GND between the DC-DC output and the terminal FB. The output voltage is decided depending on the following equation.

$$V_{out} = 1.0 \times \left[1 + \frac{R_a}{R_b} \right]$$

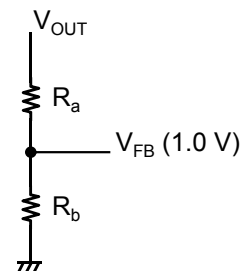

4. Min/Max Duty Operation

Note) The characteristics listed below are reference values derived from the design of the IC and are not guaranteed.

MinDuty is decided by the minimum ON time. The minimum ON time, $T_{on}(\min)$, is the time that this IC can turn on the high side switch. This is decided by the gate capacitance of the high side switch and the internal timing delay. The following attention is necessary because in applications where the Input/Output voltage difference is great, and the switching frequency is high, there is a possibility to reach the limiting value of the minimum ON time. The minimum ON time, $T_{on}(\min)$, is about 200ns (max).

This IC has the function of MaxDuty, which will not exceed a certain definite value for safety reasons in case of abnormal circumstances. The following attention is necessary because in applications where the Input/Output voltage difference is close, and the switching frequency is high, there is a possibility to reach the limiting value of the minimum OFF time. The minimum OFF time, $T_{off}(\min)$, is about 200ns (max).

$$T_{on}(\min) < \frac{V_{out}}{V_{in}} \times \frac{1}{F}$$

$$T_{off}(\min) < \left(1 - \frac{V_{out}}{V_{in}} \right) \times \frac{1}{F}$$

*) F : Switching frequency

When operating near the Min/Max limited duty, the ripple voltage and the inductor current ripple increases even if the output voltage is stabilized. It is recommended to use on the condition when the turn on switching time and turn off switching time are 200ns or more.

*) Please take note of the output voltage setting when the switching frequency is high.

OPERATION (Continued)

5. Oscillation Frequency

Note) The characteristics listed below are reference values derived from the design of the IC and are not guaranteed.

The switching frequency of the built-in oscillator circuit can be set from 200 kHz to 1000 kHz, determined by the resistance of the terminal RT, set by external resistance. The setting accuracy of the frequency is approximately $\pm 10\%$. The equation and the corresponding table are described as follows.

RT [kΩ]	OSC Frequency (kHz)	RT [kΩ]	OSC Frequency (kHz)
56	1015	150	430
62	934	160	406
68	864	180	364
75	796	200	330
82	738	220	302
91	674	240	278
100	620	270	249
110	569	300	225
120	527	330	206
130	490	360	190

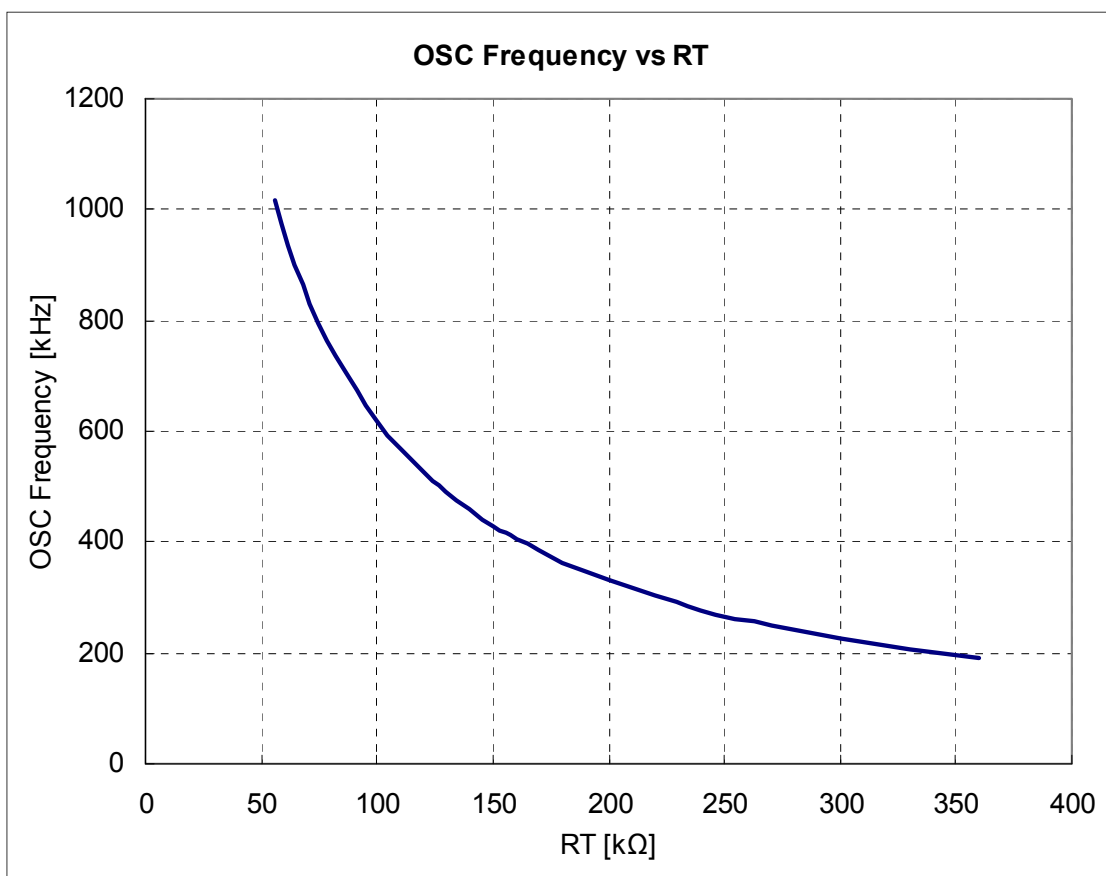

Figure : switching frequency vs external resistance

OPERATION (Continued)

6. Over-Current Protection

Note) The characteristics listed below are reference values derived from the design of the IC and are not guaranteed.

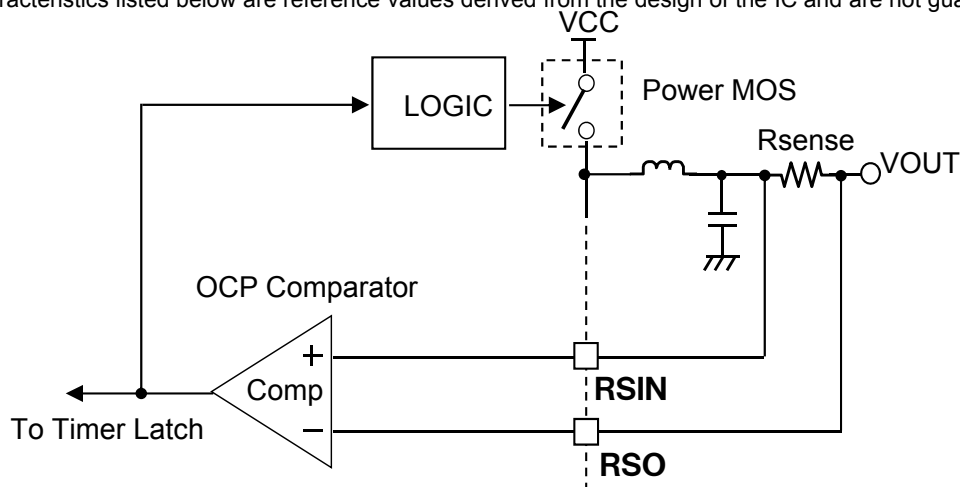

Figure : Over-Current Protection circuit block diagram

Over-current protection function (OCP) restrain output current level when IC detect that DC-DC output current is higher than setting level. It turns off the Power MOS in IC when the voltage difference of external resistance R_{sense} exceeds 90mV(Typ.) so as to stop the supply to DC-DC output. Detection current I_{sense} can be calculated as:

$$I_{sense} = 90mV / R_{sense}$$

For safety reason, OCP function is necessary. Please placed sense resistor ($\geq 39m\Omega$) between $RSIN$ and RSO as indicated in above figure.

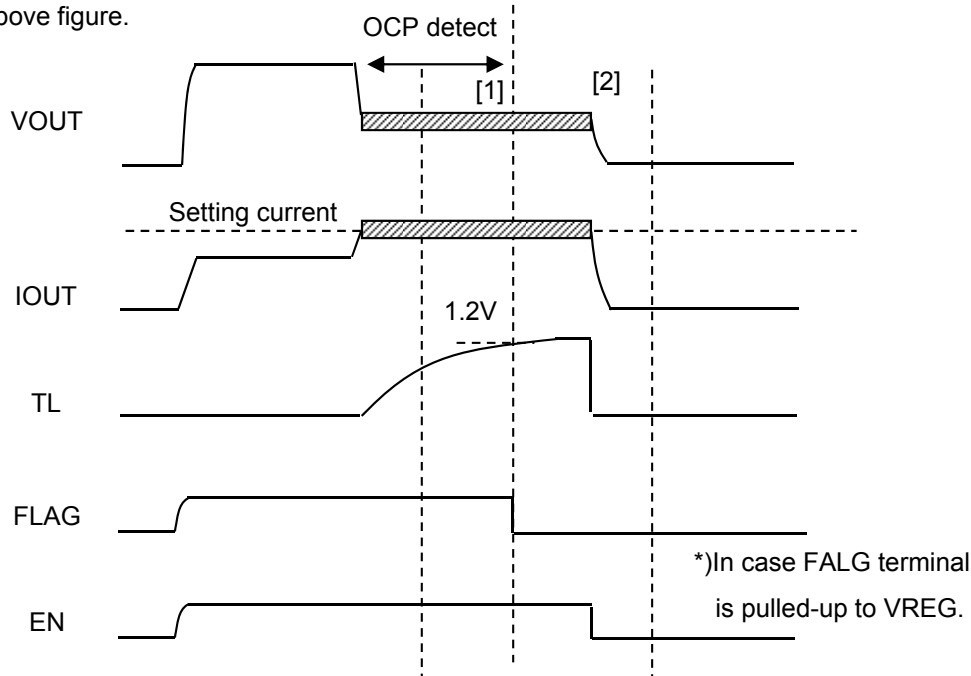

Figure : Method of detection of Over-Current Protection function

[1].DC-DC continue to ON and OFF when OCP detect. It restrain average level of DC-DC output voltage and DC-DC output current.

[2].FLAG output become low when you keep abnormal condition longer than setting time of Timer Latch function.

For safety reason, please disable DC-DC by EN control when FLAG output become low.

OPERATION (Continued)

7. Current Feedback function

Note) The characteristics listed below are reference values derived from the design of the IC and are not guaranteed.

The following expression shows the relation between Current Feedback Adjustment Resistance RRADJ and Sense Resistance RSENSE and Impedance R_{cable} (ex. External connection cables).

$$R_{RADJ} = Ra \frac{4 \times RSENSE}{Rcable} [\Omega]$$

The following expression shows the relation between Voltage V_{USB} and RRADJ.

$$V_USB = \left\{ 1 + Ra \times \left(\frac{1}{Rb} + \frac{4 \times RSENSE \times IOOUT}{RRADJ \times 1.0} \right) \right\} \times 1.0 - Rcable \times IOOUT [V]$$

With respect to above equations,

- 1) IOOUT is current flowing through RSENSE.
- 2) 1.0 [V] is the internal reference voltage (VREF) of IC.

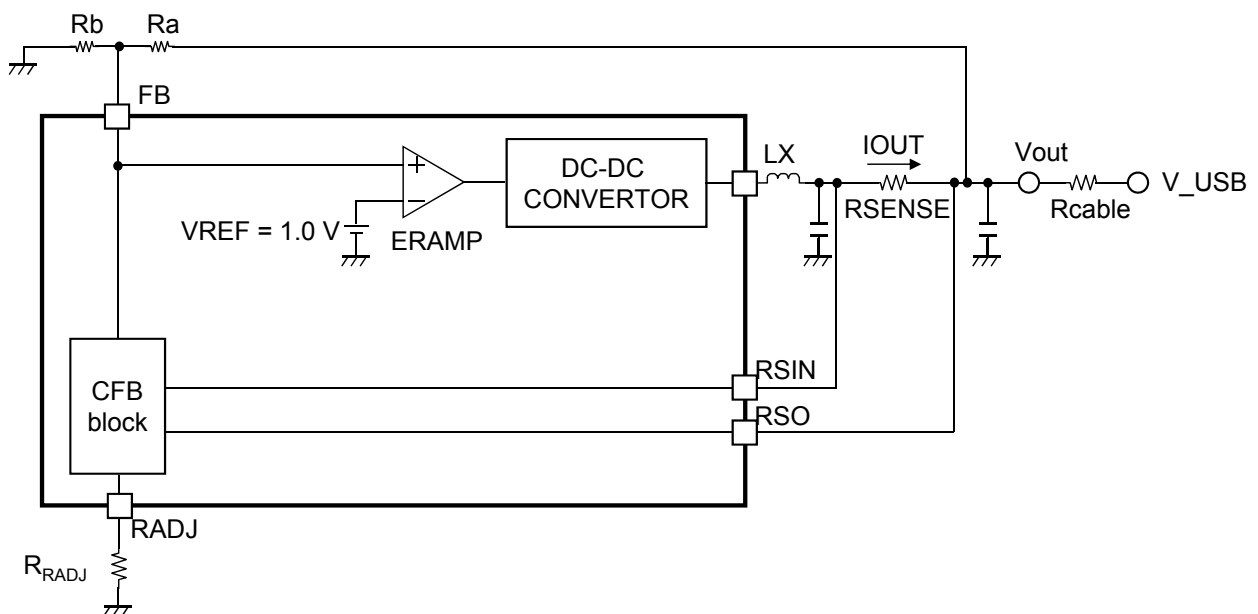

Figure : The diagram of current feed back function

※ This function is suitable at below conditions: output voltage range from 3 V to 7 V, R_{cable} resistance is equal or less than 1.0 Ω .

The voltage of RSIN pin and RSO pin might be higher than its absolute voltage when R_{cable} is over than 1.0Ω. In case there is a change of R_{cable}'s impedance to more than 1.0 Ω by external factor such as a heat, drop in V_{USB} voltage is to be expected. Referring to formula V_{USB}* above, when R_{cable} increased and Radj remain constant, V_{USB} will drop.

As a safety measure, a sensing resistor must be inserted between RSIN pin & RSO pin to enable the over-current protection function. Sensing resistor value of more than 39 mΩ is recommended.

OPERATION (Continued)

7. Current Feedback function (continued)

Note) The characteristics listed below are reference values derived from the design of the IC and are not guaranteed.

The following expression shows the relation between IO_{UT} and voltage drop ΔV of Impedance R_{cable} (ex. External connection cables).

$$\Delta V = R_{cable} \times IO_{UT}$$

The following expression shows the relation between above formula and Voltage V_{_USB} and R_{RADJ}.

$$\Delta V = 1 + Ra \times \left(\frac{1}{Rb} + \frac{4 \times RSENSE \times IO_{UT}}{R_{RADJ} \times 1.0} \right) \times 1.0V - V_{_USB} [V]$$

At this point,

$$V_{out} = 1 + Ra \times \left(\frac{1}{Rb} + \frac{4 \times RSENSE \times IO_{UT}}{R_{RADJ} \times 1.0} \right) \times 1.0V [V]$$

The following graph shows the expression of ΔV = V_{out} – V_{_USB} against IO_{UT}.

The condition is Ra = 31.2 kΩ, Rb = 7.5 kΩ, RSENSE = 56 mΩ.

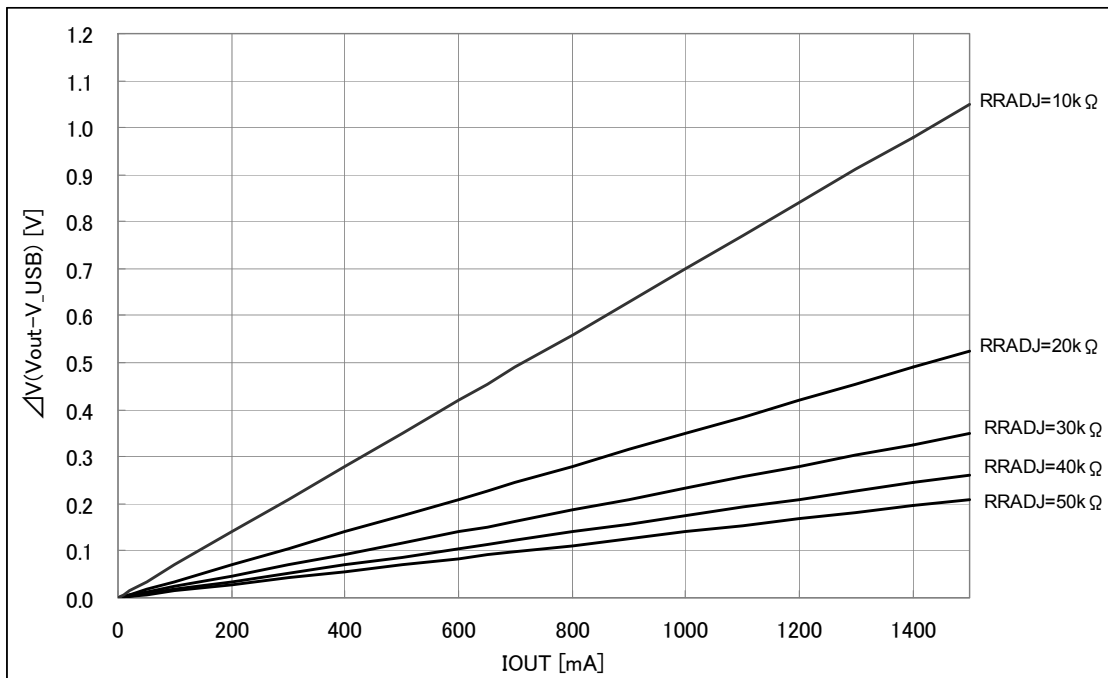

Figure : Δ= V_{out} – V_{_USB} vs IO_{UT}

OPERATION (Continued)

8. Over current protection setting

Note) The characteristics listed below are reference values derived from the design of the IC and are not guaranteed.

As a safety measure, a sensing resistor must be inserted between RSIN pin & RSO pin to enable the over-current protection function. Sensing resistor value of more than 39 m Ω is recommended.

If sensing resistor is set at less than 39 m Ω , the capacitor at TL pin should be as small as possible or open to minimize reaction time of Timer Latch block. Please consider the implementation of full evaluation and verification for this setting. Take notice the power dissipation of Sensing resistor.

If the impedance of ferrite beads is 30 Ω (at 100MHz), over current detection level (ISENSE) is shown below.

$$ISENSE(yp)=90mV/RSENSE (90mV : detection level of OCP (typ))$$

If the impedance of ferrite beads is not 30 Ω (at 100MHz), over current detection level (ISENSE) is shown below.

$$ISENSE(yp) = (0.0042R - 0.0272)x^2 + (-0.0004R + 0.8797)x$$

R : Impedance of ferrite beads (Ω at 100MHz) x : 90mV/RSENSE

If the impedance of ferrite beads is not 30 Ω (at 100MHz), please adjust RSENSE for setting to desired ISENSE by above formula.

9. FLAG function after Over current / Short current detection

Note) The characteristics listed below are reference values derived from the design of the IC and are not guaranteed.

Stop this product by forcing EN pin to Low when detect OCP or SCP condition by FLAG pin.
In situation when RSIN RSO are less than 1.1V, do note that only SCP detection is active.

When FB is equal or lower than 0.3 V, short current detection is triggered, FLAG pin will be pull to Low state. The response timing is determined by TL pin capacitor value CTL (The response timing = CTL / 2 μ A \times 1.2V).
Note that the pull down current drivability of FLAG pin is 1.2 mA.

Adjusting of FLAG response time in event of "over current" or "short current" condition is make possible by changing the capacitance of TL pin.

In the event of over current detection, FLAG pin will be pull to Low state. Once FLAG is pull to Low state, it will remained at Low state until IC is reset through EN pin.

10. Thermal Shut Down (TSD)

Note) The characteristics listed below are reference values derived from the design of the IC and are not guaranteed.

When the LSI internal temperature becomes more than about 165 $^{\circ}$ C, TSD operates and DC-DC turns off.

OPERATION (Continued)

11. Soft Start Timing and Setting

Note) The characteristics listed below are reference values derived from the design of the IC and are not guaranteed.

This IC includes a soft start function whereby start-up time can be set to desired timing by adjusting the SS terminal capacitor (C_{SS}). By adjusting the soft-start time, rush current from the Power supply terminal can be limited and the start-up timing of the output voltage can be changed. The timing chart and the method of selecting the external capacitor value is shown in below.

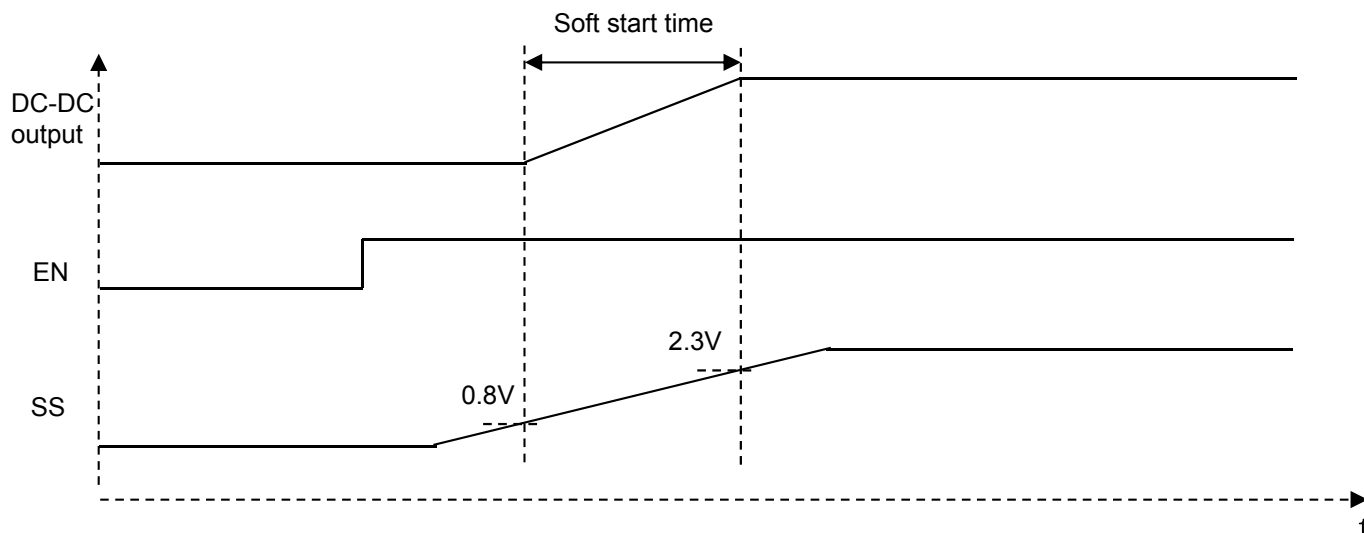

Figure : Soft start operation timing chart

Equation to set soft start time by C_{SS} : Soft - Start Time (s) $\approx \frac{1.5}{2.2 \mu} \cdot C_{SS}$

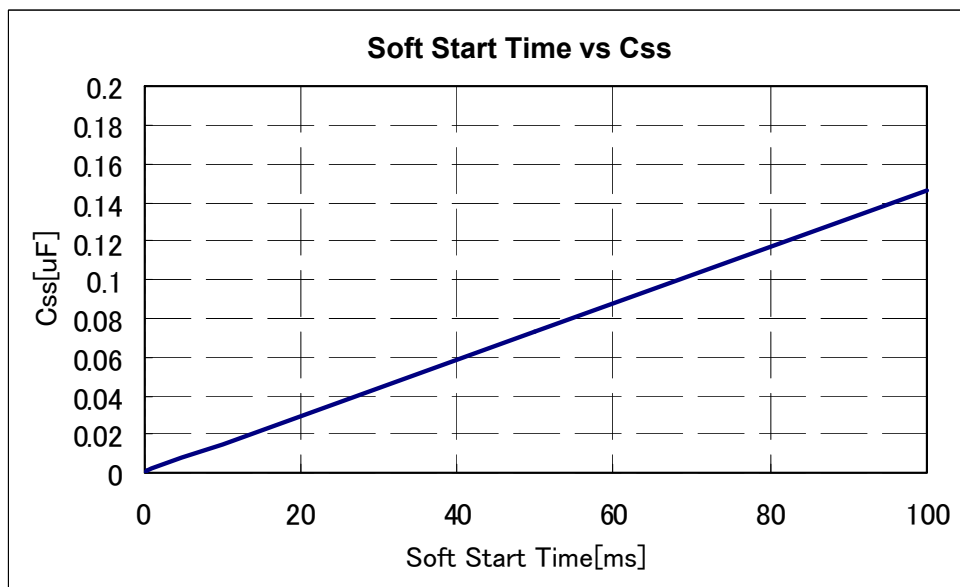

Figure : Soft Start Time vs C_{SS} Value (External Capacitor)

When this IC is used for power supply of communication with external equipment, the communication may not possible during the soft-start period. Depending on the type of external equipment connected, in some cases, when the DC-DC is turned on, even though the soft start maybe halfway through, the voltage level is high enough to enable the communication to start. In such cases, the micro-controller may not recognize the equipment normally and therefore it is required to set the micro-controller to access all possible equipment after the above soft-start setting time.

APPLICATIONS INFORMATION

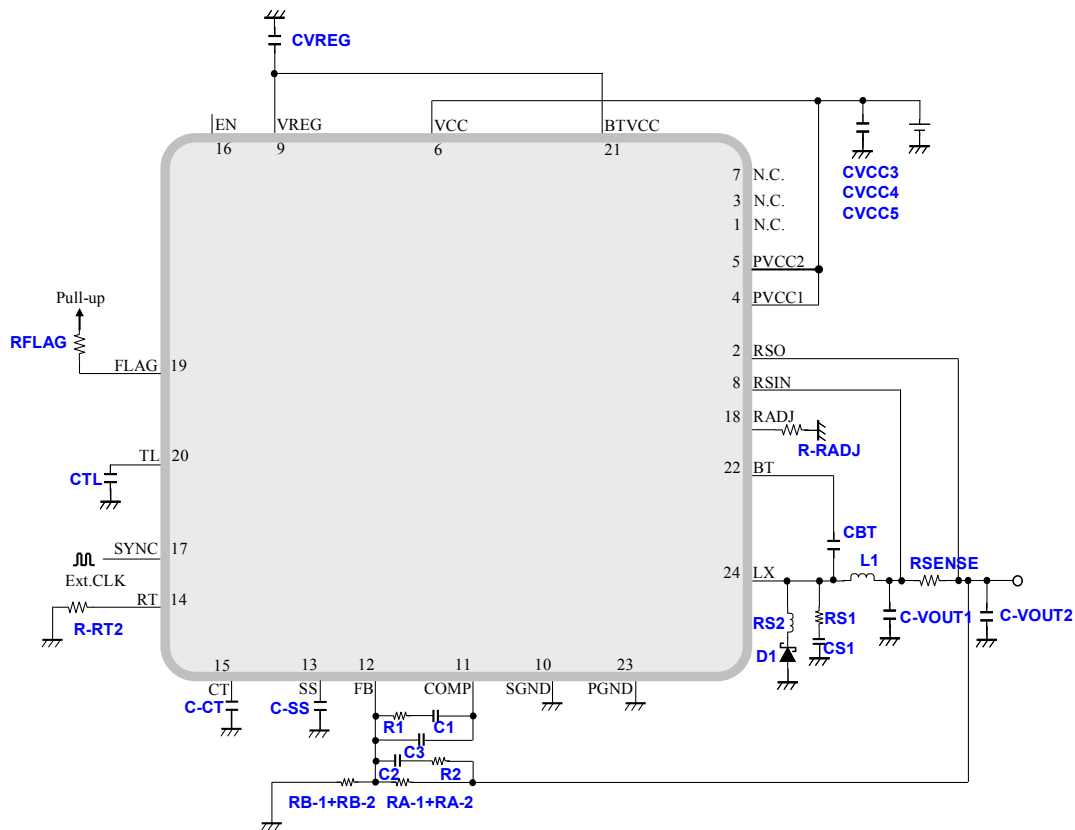

Figure : Application circuit

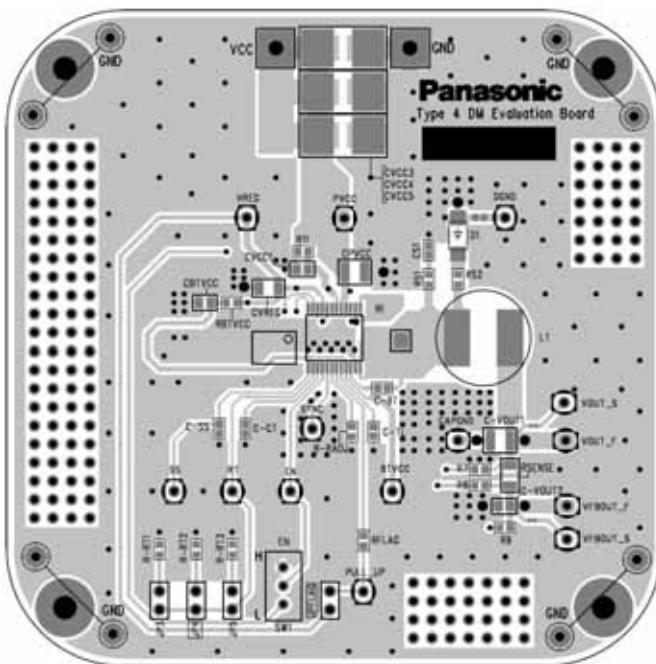

Figure : Top Layer with silk screen
 (Top View) with Evaluation board

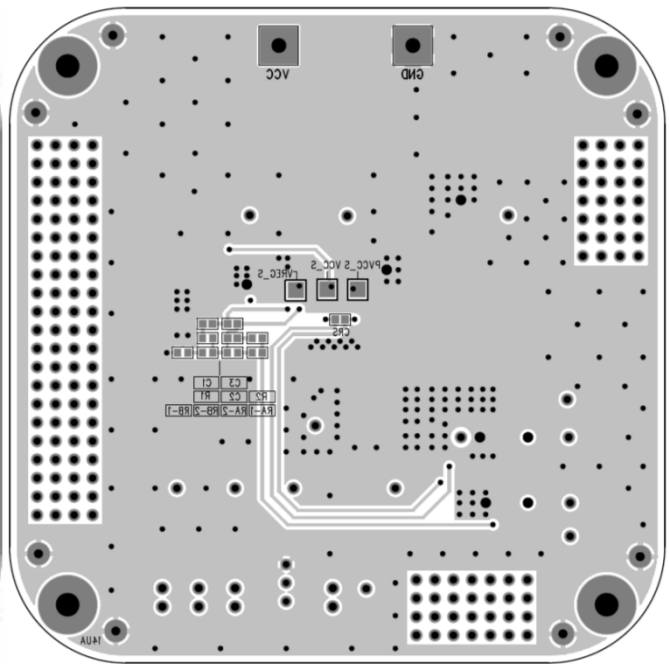

Figure : Bottom Layer with silk screen
 (Bottom View) with Evaluation board

Notes) This application circuit and layout is an example. The operation of mass production set is not guaranteed. You should perform enough evaluation and verification on the design of mass production set. You are fully responsible for the incorporation of the above application circuit and information in the design of your equipment.

APPLICATIONS INFORMATION (Continued)

Reference	Part Name	Value	Maker	Description
C-BT,C-CT, C-SS,C-TL	GCM188R11C104KA01J	0.1 μ F	Murata	Setting Capacitor
C1	GCM1882C1H222JA01J	2.2nF	Murata	Compensation Capacitor
C2	GCM1882C1H471JA01J	470pF	Murata	Compensation Capacitor
C3	GCM1882C1H270JA01J	27pF	Murata	Compensation Capacitor
CVREG	GCM188R71C105KA49J	1 μ F	Murata	VREG Capacitor
CVCC3,CVCC4, CVCC5	CKG57NX7R1H226MT	22 μ F	TDK	Input Capacitor
C-VOUT1	TMK325C7226MM-T	22 μ F	TAIYO,YUDEN	Output Capacitor
C-VOUT2	GCM188R11C104KA01J	0.1 μ F	Murata	Output Capacitor
L1	CDRH8D43-100NC	10 μ H	SUMIDA	Inductor
D1	DB24416	-	Panasonic	Schottky Diode
R1	ERA3AEB752V	R=7.5k	Panasonic	Compensation & Feedback Resistor
R2	ERA3AEB152V	R=1.5k	Panasonic	Compensation & Feedback Resistor
RA-1	ERA3AEB303V	R=30k	Panasonic	Compensation & Feedback Resistor
RB-1	ERA3AEB752V	R=7.5k	Panasonic	Compensation & Feedback Resistor
R-RADJ	ERA3AEB303V	R=30k	Panasonic	Current Feedback Adjustment Resistor
RFLAG	ERA3AEB204V	R=200k	Panasonic	Pull-up Resistor
R-RT2	ERA3AEB134V	R=130k	Panasonic	OSC Setting Resistor (Fsw=490kHz)
RSENSE	ERJ6BWFR050V	R=50m	Panasonic	Output Current Sense Resistor
RA-2,RB-2,R7, R8,R9,RBTVCC	ERJ3GEY0R00V	R=0	Panasonic	-
CS1	GCM1882C1H332JA01J	3300pF	Murata	Snubber Circuit
RS1	ERA3AEB221V	R=220	Panasonic	Snubber Circuit
RS2	MPZ1608S300A	-	TDK	Ferrite Beads

Figure : Recommended component

PACKAGE INFORMATION (Reference Data)

Outline Drawing

Package Code : SSOP024-P-0300F

Unit : mm

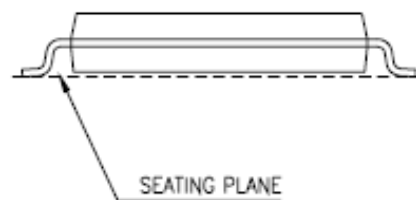
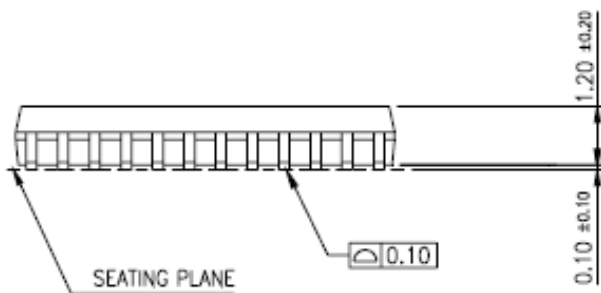
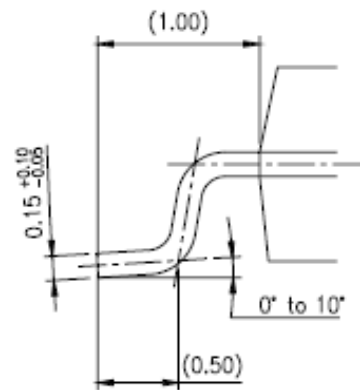
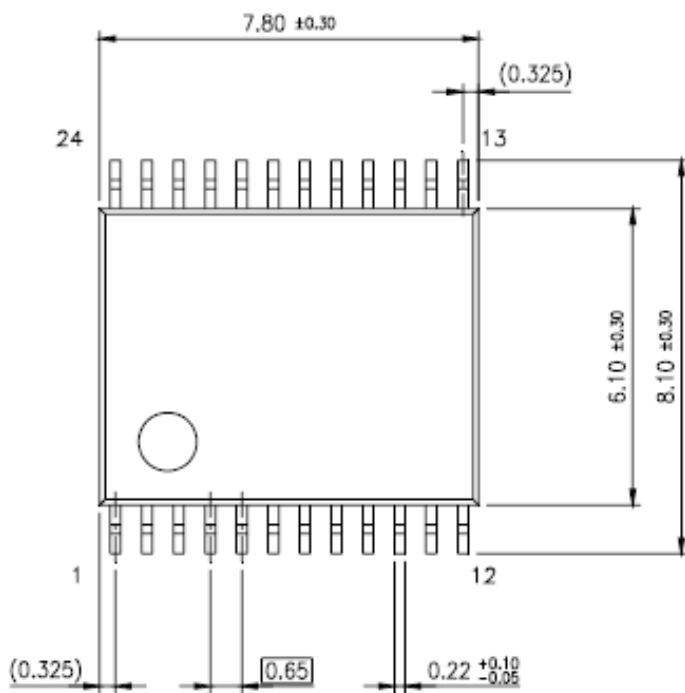

Body Material : Br/Sb Free Epoxy resin
Lead Material : Cu Alloy
Lead Finish Method : SnBi Plating

IMPORTANT NOTICE

1. When using the LSI for new models, verify the safety including the long-term reliability for each product.
2. When the application system is designed by using this LSI, please confirm the notes in this book.
Please read the notes to descriptions and the usage notes in the book.
3. This LSI is intended to be used for general electronic equipment.
Consult our sales staff in advance for information on the following applications: Special applications in which exceptional quality and reliability are required, or if the failure or malfunction of this LSI may directly jeopardize life or harm the human body.
Any applications other than the standard applications intended.
 - (1) Space appliance (such as artificial satellite, and rocket)
 - (2) Traffic control equipment (such as for airplane, train, and ship)
 - (3) Medical equipment for life support
 - (4) Submarine transponder
 - (5) Control equipment for power plant
 - (6) Disaster prevention and security device
 - (7) Weapon
 - (8) Others : Applications of which reliability equivalent to (1) to (7) is requiredOur company shall not be held responsible for any damage incurred as a result of or in connection with the LSI being used for any special application, unless our company agrees to the use of such special application.
4. Please use this product in compliance with all applicable laws and regulations that regulate the inclusion or use of controlled substances, including without limitation, the EU RoHS Directive. Our company shall not be held responsible for any damage incurred as a result of our LSI being used by our customers, not complying with the applicable laws and regulations.
5. Pay attention to the direction of LSI. When mounting it in the wrong direction onto the PCB (printed-circuit-board), it might emit smoke or ignite.
6. Pay attention in the PCB (printed-circuit-board) pattern layout in order to prevent damage due to short circuit between pins. In addition, refer to the Pin Description for the pin configuration.
7. Perform a visual inspection on the PCB before applying power, otherwise damage might happen due to problems such as a solder-bridge between the pins of the semiconductor device. Also, perform a full technical verification on the assembly quality, because the same damage possibly can happen due to conductive substances, such as solder ball, that adhere to the LSI during transportation.
8. Take notice in the use of this product that it might be damaged or occasionally emit smoke when an abnormal state occurs such as output pin-VCC short (Power supply fault), output pin-GND short (Ground fault), or output-to-output-pin short (load short). Safety measures such as an installation of fuses are recommended because the extent of the above-mentioned damage and smoke emission will depend on the current capability of the power supply..
9. The protection circuit is for maintaining safety against abnormal operation. Therefore, the protection circuit should not work during normal operation.
Especially for the thermal protection circuit, if the area of safe operation or the absolute maximum rating is momentarily exceeded due to output pin to VCC short (Power supply fault), or output pin to GND short (Ground fault), the LSI might be damaged before the thermal protection circuit could operate.
10. Unless specified in the product specifications, make sure that negative voltage or excessive voltage are not applied to the pins because the device might be damaged, which could happen due to negative voltage or excessive voltage generated during the ON and OFF timing when the inductive load of a motor coil or actuator coils of optical pick-up is being driven.
11. Product which has specified ASO (Area of Safe Operation) should be operated in ASO
12. Verify the risks which might be caused by the malfunctions of external components.

Request for your special attention and precautions in using the technical information and semiconductors described in this book

- (1) If any of the products or technical information described in this book is to be exported or provided to non-residents, the laws and regulations of the exporting country, especially, those with regard to security export control, must be observed.
- (2) The technical information described in this book is intended only to show the main characteristics and application circuit examples of the products. No license is granted in and to any intellectual property right or other right owned by Panasonic Corporation or any other company. Therefore, no responsibility is assumed by our company as to the infringement upon any such right owned by any other company which may arise as a result of the use of technical information de-scribed in this book.
- (3) The products described in this book are intended to be used for general applications (such as office equipment, communications equipment, measuring instruments and household appliances), or for specific applications as expressly stated in this book.
Please consult with our sales staff in advance for information on the following applications, moreover please exchange documents separately on terms of use etc.: Special applications (such as for in-vehicle equipment, airplanes, aerospace, automotive equipment, traffic signaling equipment, combustion equipment, medical equipment and safety devices) in which exceptional quality and reliability are required, or if the failure or malfunction of the products may directly jeopardize life or harm the human body.
Unless exchanging documents on terms of use etc. in advance, it is to be understood that our company shall not be held responsible for any damage incurred as a result of or in connection with your using the products described in this book for any special application.
- (4) The products and product specifications described in this book are subject to change without notice for modification and/or improvement. At the final stage of your design, purchasing, or use of the products, therefore, ask for the most up-to-date Product Standards in advance to make sure that the latest specifications satisfy your requirements.
- (5) When designing your equipment, comply with the range of absolute maximum rating and the guaranteed operating conditions (operating power supply voltage and operating environment etc.). Especially, please be careful not to exceed the range of absolute maximum rating on the transient state, such as power-on, power-off and mode-switching. Otherwise, we will not be liable for any defect which may arise later in your equipment.
Even when the products are used within the guaranteed values, take into the consideration of incidence of break down and failure mode, possible to occur to semiconductor products. Measures on the systems such as redundant design, arresting the spread of fire or preventing glitch are recommended in order to prevent physical injury, fire, social damages, for example, by using the products.
- (6) Comply with the instructions for use in order to prevent breakdown and characteristics change due to external factors (ESD, EOS, thermal stress and mechanical stress) at the time of handling, mounting or at customer's process. We do not guarantee quality for disassembled products or the product re-mounted after removing from the mounting board.
When using products for which damp-proof packing is required, satisfy the conditions, such as shelf life and the elapsed time since first opening the packages.
- (7) When reselling products described in this book to other companies without our permission and receiving any claim of request from the resale destination, please understand that customers will bear the burden.
- (8) This book may be not reprinted or reproduced whether wholly or partially, without the prior written permission of our company.



Looking for pricing, stock, or lifecycle information?

Click below to explore more details on WIN SOURCE:

 [View AN33014UA-VB on WIN SOURCE](#)

 [Panasonic Information](#)

Optimize Your Supply Chain with WIN SOURCE Solutions

-  Global Sourcing Solution
-  Obsolete Management
-  Cost Control Management
-  Shortage Management
-  Alternative Solution
-  Excess Inventory Management