

## 24-bit 192kHz Stereo DAC with 2Vrms Ground Referenced Line Output

### DESCRIPTION

The WM8533 is a stereo DAC with integral charge pump and software control interface. This provides 2Vrms line driver outputs using a 3.3V power supply rail.

The device features ground-referenced outputs and the use of a DC servo to eliminate the need for line driving coupling capacitors and effectively eliminate power on pops and clicks.

The device is controlled and configured either via the I<sup>2</sup>C/SPI compliant serial control interface or a hardware control interface.

The device supports all common audio sampling rates between 8kHz and 192kHz using all common MCLK / fs ratios. Master and slave modes are available and de-emphasis is also supported.

The WM8533 has a 1.8 to 3.3V tolerant digital interface, allowing logic up to 3.3V to be connected.

The device is available in a 1.842 x 1.772mm 20-ball WCSP.

### FEATURES

- High performance stereo DAC with ground referenced line driver
- Audio performance
  - 106dB SNR ('A-weighted')
  - -89dB THD @ -1dBFS
- Digital volume control ranging from -100dB to +12dB
- 120dB mute attenuation
- All common sample rates from 8kHz to 192kHz supported
- I<sup>2</sup>C/SPI compatible and hardware control modes
- Data formats: LJ, RJ, I<sup>2</sup>S, DSP
- De-emphasis supported
- Maximum 1mV DC offset on line outputs
- Pop/click suppressed power up/down sequencer
- AVDD and LINEVDD +3.3V ±10% allowing single supply
- DBVDD supply supports +1.8V or +3.3V digital I/O
- 1.842 x 1.772mm 20-ball WCSP

### APPLICATIONS

- Consumer digital audio applications requiring 2Vrms output
  - Set Top Box
  - Digital TV
  - DVD Players
  - Games Consoles
  - AV Receivers

### BLOCK DIAGRAM

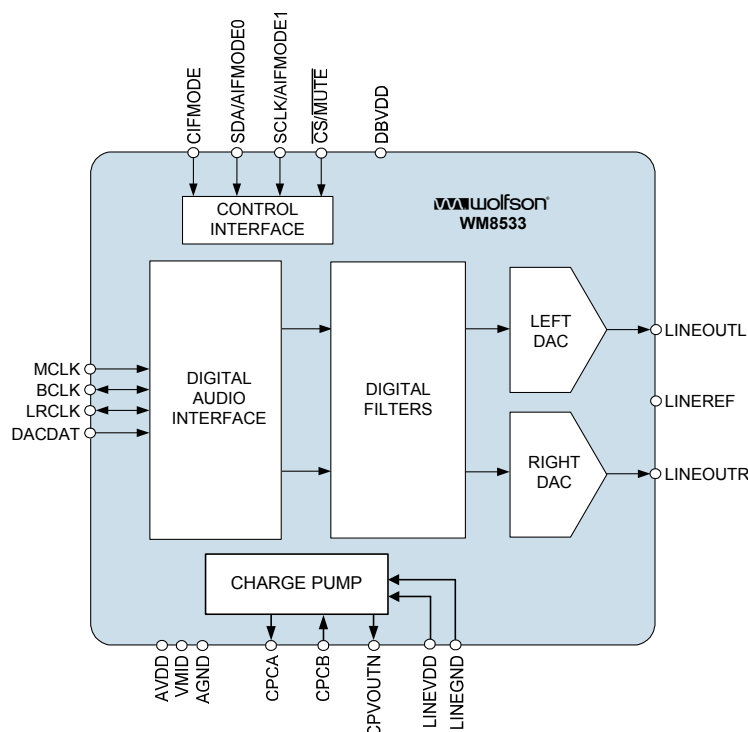

## TABLE OF CONTENTS

<b>DESCRIPTION</b> .....	<b>1</b>
<b>FEATURES</b> .....	<b>1</b>
<b>APPLICATIONS</b> .....	<b>1</b>
<b>BLOCK DIAGRAM</b> .....	<b>1</b>
<b>TABLE OF CONTENTS</b> .....	<b>2</b>
<b>PIN CONFIGURATION</b> .....	<b>3</b>
<b>ORDERING INFORMATION</b> .....	<b>3</b>
<b>PIN DESCRIPTION</b> .....	<b>4</b>
<b>ABSOLUTE MAXIMUM RATINGS</b> .....	<b>5</b>
<b>RECOMMENDED OPERATING CONDITIONS</b> .....	<b>5</b>
<b>ELECTRICAL CHARACTERISTICS</b> .....	<b>6</b>
TERMINOLOGY.....	7
<b>TYPICAL PERFORMANCE</b> .....	<b>7</b>
TYPICAL POWER CONSUMPTION .....	7
<b>SIGNAL TIMING REQUIREMENTS</b> .....	<b>8</b>
SYSTEM CLOCK TIMING.....	8
AUDIO INTERFACE TIMING – MASTER MODE .....	9
AUDIO INTERFACE TIMING – SLAVE MODE.....	10
CONTROL INTERFACE TIMING – I <sup>2</sup> C MODE .....	11
CONTROL INTERFACE TIMING – SPI MODE .....	12
POWER ON RESET .....	13
<b>DEVICE DESCRIPTION</b> .....	<b>15</b>
INTRODUCTION.....	15
SOFTWARE CONTROL INTERFACE .....	15
DIGITAL AUDIO INTERFACE.....	19
DIGITAL AUDIO INTERFACE CONTROL .....	21
DIGITAL AUDIO DATA SAMPLING RATES.....	23
DAC FEATURES.....	24
HARDWARE CONTROL INTERFACE .....	28
<b>REGISTER MAP</b> .....	<b>30</b>
REGISTER BITS BY ADDRESS .....	31
<b>DIGITAL FILTER CHARACTERISTICS</b> .....	<b>35</b>
TERMINOLOGY.....	35
DAC FILTER RESPONSES .....	36
DIGITAL DE-EMPHASIS CHARACTERISTICS.....	37
<b>RECOMMENDED EXTERNAL COMPONENTS</b> .....	<b>38</b>
RECOMMENDED ANALOGUE LOW PASS FILTER .....	39
RELEVANT APPLICATION NOTES .....	39
<b>PACKAGE DIMENSIONS</b> .....	<b>40</b>
<b>IMPORTANT NOTICE</b> .....	<b>41</b>
ADDRESS .....	41

## PIN CONFIGURATION

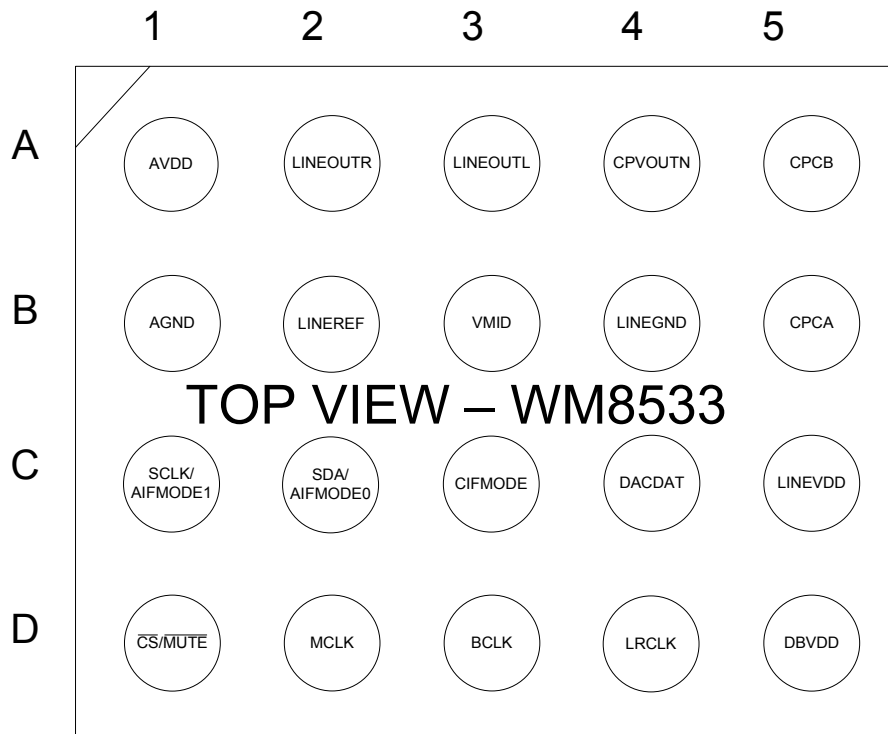

## ORDERING INFORMATION

DEVICE	TEMPERATURE RANGE	PACKAGE	MOISTURE SENSITIVITY LEVEL	PEAK SOLDERING TEMPERATURE
WM8533ECSN/R	-40 to +85°C	20-ball W-CSP (Pb-free, tape and reel)	MSL1	260°C

**Note:**

Reel quantity = 5000

## PIN DESCRIPTION

PIN NO	NAME	TYPE	DESCRIPTION		
A1	AVDD	Supply	Analogue supply		
A2	LINEOUTR	Analogue Out	Right line output		
A3	LINEOUTL	Analogue Out	Left line output		
A4	CPVOUTN	Analogue Out	Charge pump negative rail decoupling pin		
A5	CPCB	Analogue Out	Charge pump fly back capacitor pin		
B1	AGND	Supply	Analogue ground		
B2	LINEREF	Analogue Input	Ground feedback from output jack		
B3	VMID	Analogue Out	Analogue midrail decoupling pin		
B4	LINEGND	Supply	Charge pump ground		
B5	CPCA	Analogue Out	Charge pump fly back capacitor pin		
			<b>I<sup>2</sup>C SOFTWARE MODE</b>	<b>SPI SOFTWARE MODE</b>	<b>HARDWARE MODE</b>
C1	SCLK/ AIFMODE1	Digital I/O	I <sup>2</sup> C control interface clock input pin	SPI control interface clock input pin	<b>AIFMODE [1:0]</b> 00 = 24-bit LJ 01 = 24-bit I2S 10 = 16-bit RJ 11 = 24-bit RJ
C2	SDA/ AIFMODE0	Digital I/O	I <sup>2</sup> C interface data input pin	SPI control interface data input pin	
C3	CIFMODE	Digital In Tri-Level	0 = select I <sup>2</sup> C control interface mode	1 = select SPI control interface mode	Z = select hardware mode
C4	DACDAT	Digital In	Digital audio interface data input		
C5	LINEVDD	Supply	Charge pump supply		
D1	$\overline{CS}$ / MUTE	Digital In	I <sup>2</sup> C address select: 0 = 0x34 1 = 0x36	SPI control interface chip select	0 = Mute enabled 1 = Mute disabled
D2	MCLK	Digital In	Master clock		
D3	BCLK	Digital I/O	Digital audio interface bit clock		
D4	LRCLK	Digital I/O	Digital audio interface left/right clock		
D5	DBVDD	Supply	Digital interface supply (for digital audio and I2C interfaces)		

**Note:** Tri-level pins which require the 'Z' state to be selected should be left floating (open)

## ABSOLUTE MAXIMUM RATINGS

Absolute Maximum Ratings are stress ratings only. Permanent damage to the device may be caused by continuously operating at or beyond these limits. Device functional operating limits and guaranteed performance specifications are given under Electrical Characteristics at the test conditions specified.



ESD Sensitive Device. This device is manufactured on a CMOS process. It is therefore generically susceptible to damage from excessive static voltages. Proper ESD precautions must be taken during handling and storage of this device.

Wolfson tests its package types according to IPC/JEDEC J-STD-020B for Moisture Sensitivity to determine acceptable storage conditions prior to surface mount assembly. These levels are:

MSL1 = unlimited floor life at <math>30^{\circ}\text{C}</math> / 85% Relative Humidity. Not normally stored in moisture barrier bag.

MSL2 = out of bag storage for 1 year at <math>30^{\circ}\text{C}</math> / 60% Relative Humidity. Supplied in moisture barrier bag.

MSL3 = out of bag storage for 168 hours at <math>30^{\circ}\text{C}</math> / 60% Relative Humidity. Supplied in moisture barrier bag.

The Moisture Sensitivity Level for each package type is specified in Ordering Information.

CONDITION	MIN	MAX
AVDD, LINEVDD, DBVDD	-0.3V	+4.5V
Voltage range digital inputs	AGND -0.3V	DBVDD +0.3V
Voltage range analogue inputs	AGND -0.3V	AVDD +0.3V
Temperature range, $T_A$	-40°C	+85°C
Storage temperature after soldering	-65°C	+150°C

## RECOMMENDED OPERATING CONDITIONS

PARAMETER	SYMBOL	TEST CONDITIONS	MIN	TYP	MAX	UNIT
Analogue supply range	AVDD, LINEVDD		2.97	3.3	3.63	V
Digital buffer supply range	DBVDD		1.62		3.63	V
Ground	AGND, LINEGND			0		V

### Notes

- Analogue grounds must always be within 0.3V of each other.
- LINEVDD and AVDD must always be within 0.3V of each other.

## ELECTRICAL CHARACTERISTICS

## Test Conditions

LINEVDD=AVDD=3.3V, DBVDD=1.8V, LINEGND=AGND=0V, T<sub>A</sub>=+25°C,  
Slave Mode, fs=48kHz, MCLK=256fs, 24-bit data, unless otherwise stated.

PARAMETER	SYMBOL	TEST CONDITIONS	MIN	TYP	MAX	UNIT
<b>Analogue Output</b>						
Output Level		0dBFS	1.89	2.1	2.31	V <sub>rms</sub>
Load Impedance			1			kΩ
Load Capacitance		No external RC filter			300	pF
		With filter shown in Figure 36			1	μF
<b>DAC Performance</b>						
Signal to Noise Ratio	SNR	R <sub>L</sub> = 10kΩ A-weighted	100	106		dB
		R <sub>L</sub> = 10kΩ Un-weighted		104		dB
Dynamic Range	DNR	R <sub>L</sub> = 10kΩ A-weighted		106		
Total Harmonic Distortion	THD	R <sub>L</sub> = 10kΩ -1dBFS		-89		dB
		R <sub>L</sub> = 10kΩ 0dBFS		-86	-78	
Power Supply Rejection Ratio (AVDD or LINEVDD)	PSRR	100Hz		54		dB
		1kHz		54		
		20kHz		50		
Channel Separation		1kHz		95		dB
		20Hz to 20kHz		72		
System Absolute Phase		1kHz		0		Degrees
Channel Level Matching					0.1	dB
Hardware Mute Attenuation				120		dB
Digital Soft Mute Attenuation				100		dB
DC Offset at LINEOUTL and LINEOUTR				0	+/-1	mV
LINEREF Rejection		1kHz		55		dB
		20kHz		37		dB
<b>Digital Logic Levels</b>						
Input HIGH Level	V <sub>IH</sub>		0.7× DBVDD			V
Input LOW Level	V <sub>IL</sub>				0.3× DBVDD	V
Output HIGH Level	V <sub>OH</sub>	I <sub>OH</sub> = 1mA	0.9× DBVDD			V
Output LOW Level	V <sub>OL</sub>	I <sub>OL</sub> = -1mA			0.1× DBVDD	V
Input Capacitance				10		pF
Input Leakage				0	+/-0.9	μA

## TERMINOLOGY

1. Signal-to-Noise Ratio (dB) – SNR is a measure of the difference in level between the maximum theoretical full scale output signal and the output with no input signal applied.
2. Total Harmonic Distortion (dB) – THD is the level of the rms value of the sum of harmonic distortion products relative to the amplitude of the measured output signal.
3. All performance measurements carried out with 20kHz low pass filter, and where noted an A-weighted filter. Failure to use such a filter will result in higher THD and lower SNR readings than are found in the Electrical Characteristics. The low pass filter removes out of band noise; although it is not audible it may affect dynamic specification values.
4. Mute Attenuation – This is a measure of the difference in level between the full scale output signal and the output with mute applied.

## TYPICAL PERFORMANCE

### TYPICAL POWER CONSUMPTION

<b>Test Conditions</b> LINEVDD=AVDD=3.3V, DBVDD=1.8V, LINEGND=AGND=0V, T <sub>A</sub> =+25°C, Slave Mode, quiescent (no signal)									
TEST CONDITIONS		I <sub>AVDD</sub>		I <sub>LINEVDD</sub>		I <sub>DBVDD</sub>		TOTAL	
		(mA)	(mW)	(mA)	(mW)	(mA)	(mW)	(mA)	(mW)
Off	No clocks applied SYS_ENA [1:0]=00	0.7	2.31	0.9	2.97	0.05	0.09	1.65	5.37
<b>fs=48kHz, MCLK=256fs</b>									
Standby	SYS_ENA [1:0]=01	0.2	0.66	2.0	6.6	0.1	0.18	2.3	7.44
Playback	SYS_ENA [1:0]=11	4.4	14.52	6.0	19.8	0.1	0.18	10.5	34.5
<b>fs=96kHz, MCLK=256fs</b>									
Standby	SYS_ENA [1:0]=01	0.2	0.66	2.8	9.24	0.1	0.18	3.1	10.08
Playback	SYS_ENA [1:0]=11	4.9	16.17	8.5	28.05	0.1	0.18	13.5	44.4
<b>fs=192kHz, MCLK=128fs</b>									
Standby	SYS_ENA [1:0]=01	0.2	0.66	2.8	9.24	0.1	0.18	3.1	10.08
Playback	SYS_ENA [1:0]=11	4.9	16.17	8.5	28.05	0.1	0.18	13.5	44.4

## SIGNAL TIMING REQUIREMENTS

### SYSTEM CLOCK TIMING

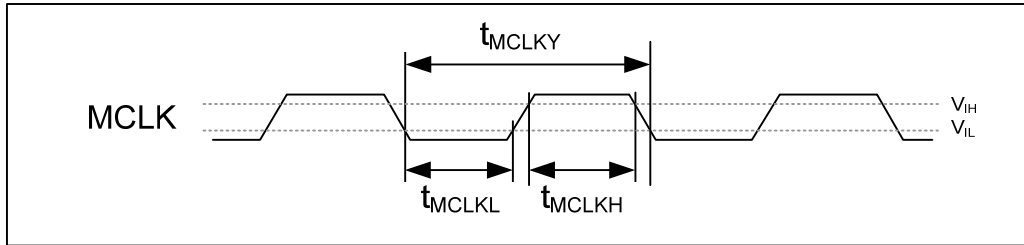

Figure 1 System Clock Timing Requirements

#### Test Conditions

The following timing information is valid across the full range of recommended operating conditions.

PARAMETER	SYMBOL	MIN	TYP	MAX	UNIT
<b>Master Clock Timing Information</b>					
MCLK cycle time	t <sub>MCLKY</sub>	27		500	ns
MCLK high time	t <sub>MCLKH</sub>	11			ns
MCLK low time	t <sub>MCLKL</sub>	11			ns
MCLK duty cycle (t <sub>MCLKH</sub> /t <sub>MCLKL</sub> )		40:60		60:40	%

## AUDIO INTERFACE TIMING – MASTER MODE

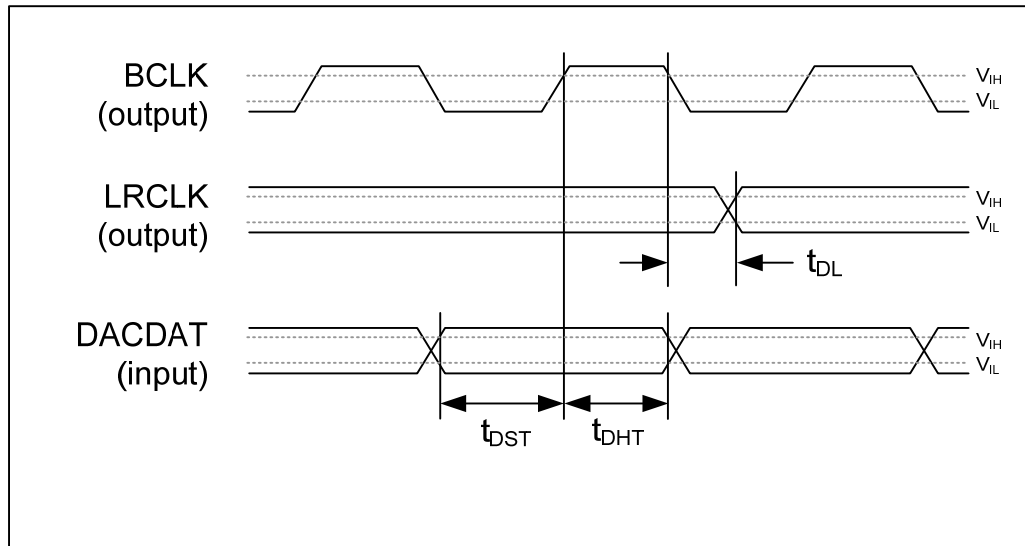

Figure 2 Master Mode Digital Audio Data Timing

## Test Conditions

The following timing information is valid across the full range of recommended operating conditions.

PARAMETER	SYMBOL	MIN	TYP	MAX	UNIT
<b>Audio Data Input Timing Information</b>					
LRCLK propagation delay from BCLK falling edge	$t_{DL}$	4		16	ns
DACDAT setup time to BCLK rising edge	$t_{DST}$	22			ns
DACDAT hold time from BCLK rising edge	$t_{DHT}$	25			ns

Table 1 Master Mode Audio Interface Timing

## AUDIO INTERFACE TIMING – SLAVE MODE

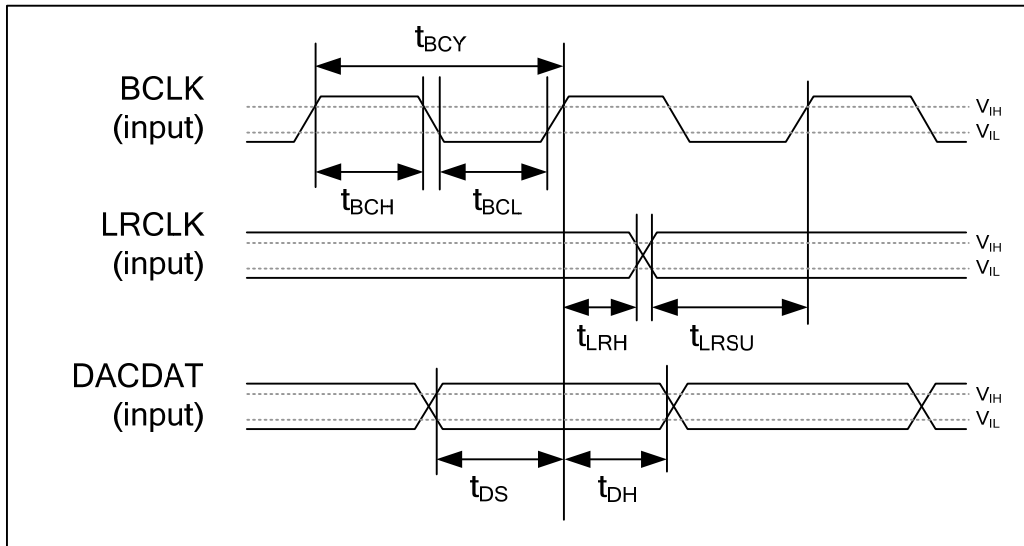

Figure 3 Digital Audio Data Timing – Slave Mode

## Test Conditions

The following timing information is valid across the full range of recommended operating conditions.

PARAMETER	SYMBOL	MIN	TYP	MAX	UNIT
<b>Audio Data Input Timing Information</b>					
BCLK cycle time	$t_{BCY}$	27			ns
BCLK pulse width high	$t_{BCH}$	11			ns
BCLK pulse width low	$t_{BCL}$	11			ns
LRCLK set-up time to BCLK rising edge	$t_{LRSU}$	7			ns
LRCLK hold time from BCLK rising edge	$t_{LRH}$	5			ns
DACDAT hold time from BCLK rising edge	$t_{DH}$	5			ns
DACDAT set-up time to BCLK rising edge	$t_{DS}$	7			ns

Table 2 Slave Mode Audio Interface Timing

**Note:** BCLK period should always be greater than or equal to MCLK period.

## CONTROL INTERFACE TIMING – I<sup>2</sup>C MODE

I<sup>2</sup>C mode is selected by driving the CIFMODE pin low.

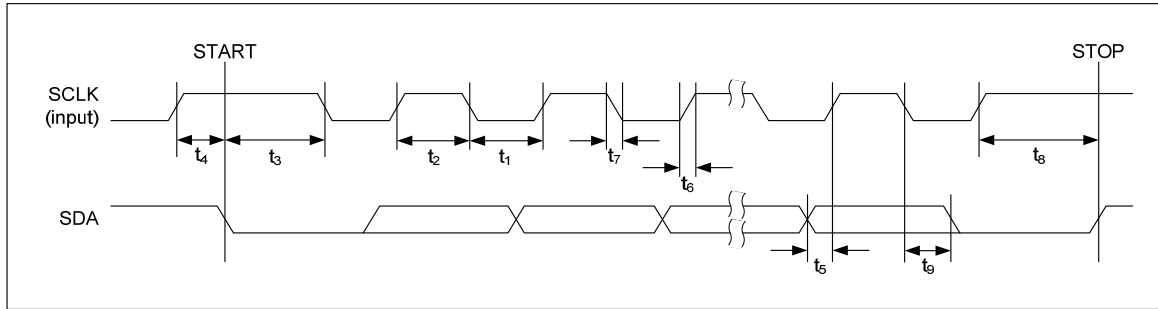

Figure 4 Control Interface Timing – I<sup>2</sup>C Control Mode

### Test Conditions

The following timing information is valid across the full range of recommended operating conditions.

PARAMETER	SYMBOL	MIN	TYP	MAX	UNIT
<b>Program Register Input Information</b>					
SCLK Frequency				400	kHz
SCLK Low Pulse-Width	$t_1$	100			ns
SCLK High Pulse-Width	$t_2$	100			ns
Hold Time (Start Condition)	$t_3$	600			ns
Setup Time (Start Condition)	$t_4$	600			ns
Data Setup Time	$t_5$	100			ns
SDA, SCLK Rise Time (see Note)	$t_6$			300	ns
SDA, SCLK Fall Time	$t_7$			300	ns
Setup Time (Stop Condition)	$t_8$	600			ns
Data Hold Time	$t_9$			900	ns
Pulse width of spikes that will be suppressed		2		8	ns

Table 3 Control Interface Timing – I<sup>2</sup>C Control Mode

Note: When SCLK frequency  $\leq$  100kHz, the maximum rise time for SDA and SCLK is increased to 1000ns.

## CONTROL INTERFACE TIMING – SPI MODE

SPI mode is selected by connecting the CIFMODE pin high.

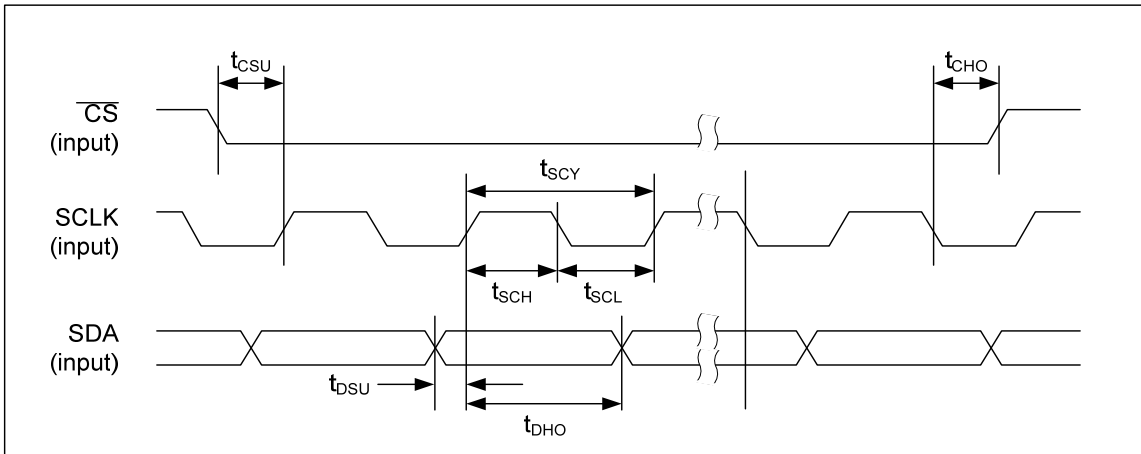

Figure 5 Control Interface Timing – SPI Control Mode

### Test Conditions

The following timing information is valid across the full range of recommended operating conditions.

PARAMETER	SYMBOL	MIN	TYP	MAX	UNIT
<b>Program Register Input Information</b>					
SCLK rising edge to $\overline{CS}$ falling edge	$t_{CSU}$	40			ns
SCLK falling edge to $\overline{CS}$ rising edge	$t_{CHO}$	40			ns
SCLK pulse cycle time	$t_{SCY}$	160			ns
SCLK pulse width low	$t_{SCL}$	64			ns
SCLK pulse width high	$t_{SCH}$	64			ns
SDA to SCLK set-up time	$t_{DSU}$	20			ns
SDA to SCLK hold time	$t_{DHO}$	40			ns
Pulse width of spikes that will be suppressed	$t_{ps}$	2		8	ns

Table 4 Control Interface Timing –SPI Control Mode

**POWER ON RESET**

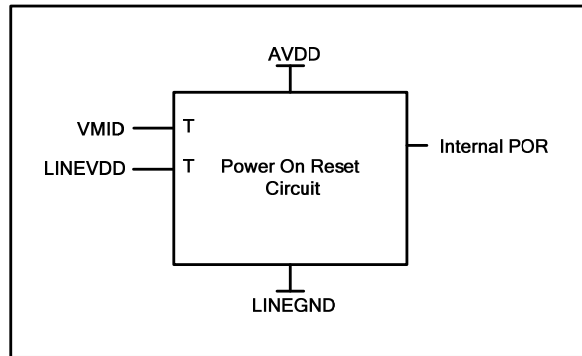

**Figure 6 Internal Power on Reset Circuit Schematic**

The WM8533 includes an internal Power-On-Reset circuit, as shown in Figure 6, which is used to reset the DAC digital logic into a default state after power up. The POR circuit is powered by AVDD and has as its inputs VMID and LINEVDD. It asserts POR low if VMID or LINEVDD are below a minimum threshold.

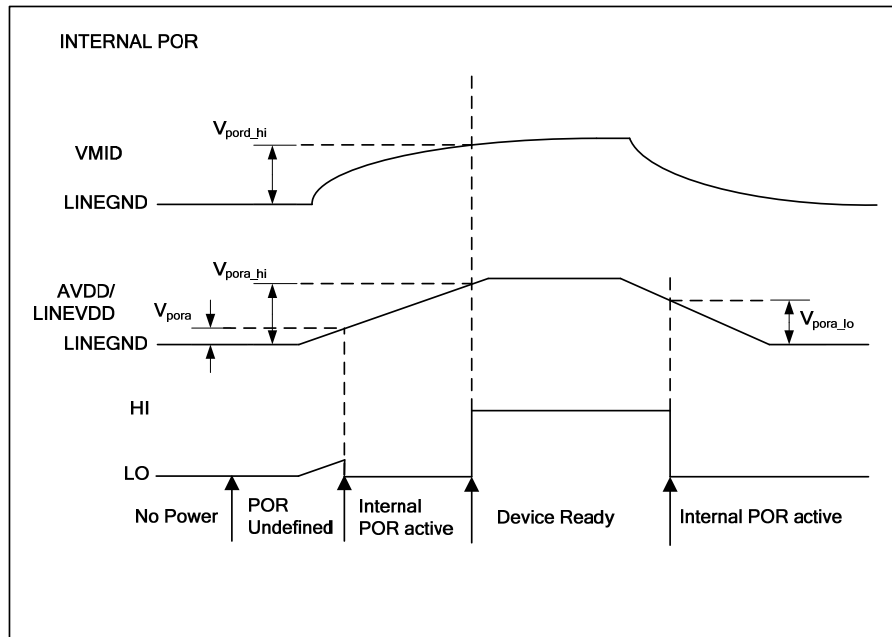

**Figure 7 Typical Power Timing Requirements**

Figure 7 shows a typical power-up sequence where LINEVDD comes up with AVDD. When AVDD goes above the minimum threshold,  $V_{pora}$ , there is enough voltage for the circuit to guarantee POR is asserted low and the chip is held in reset. In this condition, all writes to the control interface are ignored. After VMID rises to  $V_{pord\_hi}$  and AVDD rises to  $V_{pora\_hi}$ , POR is released high and all registers are in their default state and writes to the control interface may take place.

On power down, POR is asserted low whenever LINEVDD or AVDD drop below the minimum threshold  $V_{pora\_low}$ .

**Test Conditions**LINEVDD = AVDD = 3.3V, DBVDD = 1.8V, AGND = LINEGND = 0V, T<sub>A</sub> = +25°C

PARAMETER	SYMBOL	TEST CONDITIONS	MIN	TYP	MAX	UNIT
<b>Power Supply Input Timing Information</b>						
VDD level to POR defined (LINEVDD/AVDD rising)	V <sub>pora</sub>	Measured from LINEGND		158		mV
VDD level to POR rising edge (VMID rising)	V <sub>por_d_hi</sub>	Measured from LINEGND	0.63	0.8	1	V
VDD level to POR rising edge (LINEVDD/AVDD rising)	V <sub>pora_hi</sub>	Measured from LINEGND	1.44	1.8	2.18	V
VDD level to POR falling edge (LINEVDD/AVDD falling)	V <sub>pora_lo</sub>	Measured from LINEGND	0.96	1.46	1.97	V

**Table 5 Power on Reset****Note:** All values are simulated results

## DEVICE DESCRIPTION

### INTRODUCTION

The WM8533 provides high fidelity,  $2V_{rms}$  ground referenced stereo line output from a single supply line with minimal external components. The integrated DC servo eliminates the requirement for external mute circuitry by minimising DC transients at the output during power up/down. The device is well-suited to both stereo and multi-channel systems.

The device supports all common audio sampling rates between 8kHz and 192kHz using common MCLK / fs ratios. Master and slave modes are available.

The WM8533 supports both hardware and software control modes.

In hardware control mode, the digital audio interface format is switchable between 16 to 24bits LJ, RJ and I<sup>2</sup>S, and a mute control pin is also available.

In software control modes, the digital audio interface is fully programmable, with two control interface addresses to allow multiple WM8533 devices to be configured independently.

### SOFTWARE CONTROL INTERFACE

Software control mode is selected by logic 1 or 0 on the CIFMODE pin. The logic level is referenced to the DBVDD power domain. When software mode is selected, the associated multi-function control pins are defined as described in Table 6.

PIN NAME	PIN REF	DESCRIPTION
SDA	C2	Serial Data Input
SCLK	C1	Serial Data Clock
$\overline{CS}$	D1	I <sup>2</sup> C Mode - Device Address SPI Mode - Chip Select
CIFMODE	C3	Control Interface Mode 0 = I <sup>2</sup> C Mode 1 = SPI Mode Z = Hardware Mode

**Table 6 Software Control Pin Configuration**

In software control mode, the WM8533 is controlled by writing to its control registers. Readback is available for all registers, including device ID and power management status bits, in I<sup>2</sup>C control mode only. The control interface can operate as an I<sup>2</sup>C or SPI control interface: register read-back is provided on the bi-directional pin SDA in I<sup>2</sup>C mode. Note that Readback is not available in SPI mode. The WM8533 software control interface is supplied by the DBVDD power domain.

The available software control interface modes are summarised as follows:

- I<sup>2</sup>C mode uses pins SCLK and SDA.
- SPI mode uses pins  $\overline{CS}$ , SCLK and SDA.

I<sup>2</sup>C mode is selected by setting the CIFMODE pin to logic 0.

SPI mode is selected by setting the CIFMODE pin to logic 1.

## I<sup>2</sup>C CONTROL MODE

In I<sup>2</sup>C mode, the WM8533 is a slave device on the control interface; SCLK is a clock input, while SDA is a bi-directional data pin. To allow arbitration of multiple slaves (and/or multiple masters) on the same interface, the WM8533 transmits logic 1 by tri-stating the SDA pin, rather than pulling it high. An external pull-up resistor is required to pull the SDA line high so that the logic 1 can be recognised by the master.

In order to allow many devices to share a single I<sup>2</sup>C control bus, every device on the bus has a unique 8-bit device ID (this is not the same as the 8-bit address of each register in the WM8533). The device ID is determined by the logic level on the  $\overline{CS}$  pin as shown in Table 7. The LSB of the device ID is the R/W bit; this bit is set to logic 1 for "Read" and logic 0 for "Write".

$\overline{CS}$	DEVICE ID
0	0011 0100 (34h)
1	0011 0110 (36h)

**Table 7** Control Interface Device ID Selection

The WM8533 operates as an I<sup>2</sup>C slave device only. The controller indicates the start of data transfer with a high to low transition on SDA while SCLK remains high. This indicates that a device ID, register address and data will follow. The WM8533 responds to the start condition and shift in the next eight bits on SDA (8-bit device ID, including Read/Write bit, MSB first). If the device ID received matches the device address of the WM8533, then the WM8533 responds by pulling SDA low on the next clock pulse (ACK). If the device ID is not recognised or the R/W bit is set incorrectly, the WM8533 returns to the idle condition and waits for a new start condition and valid address.

If the device ID matches the device ID of the WM8533, the data transfer continues as described below. The controller indicates the end of data transfer with a low to high transition on SDA while SCLK remains high. After receiving a complete address and data sequence the WM8533 returns to the idle state and waits for another start condition. If a start or stop condition is detected out of sequence at any point during data transfer (i.e. SDA changes while SCLK is high), the device returns to the idle condition.

The WM8533 supports the following read and write operations:

- Single write
- Single read

The sequence of signals associated with a single register write operation is illustrated in Figure 8.

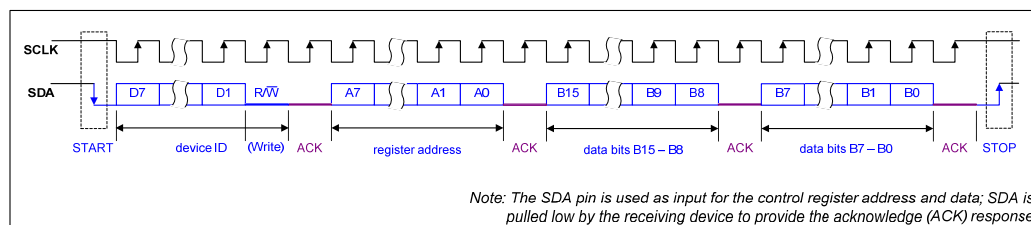

**Figure 8** Control Interface I<sup>2</sup>C Register Write

The sequence of signals associated with a single register read operation is illustrated in Figure 9.

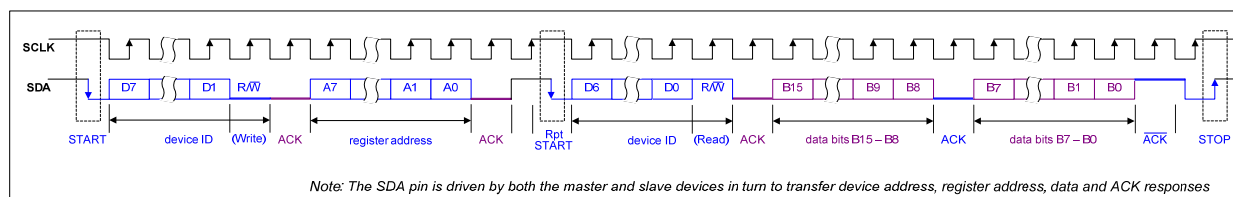

**Figure 9** Control Interface I<sup>2</sup>C Register Read

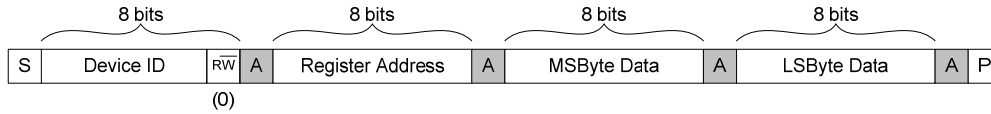

Figure 10 Single Register Write to Specified Address

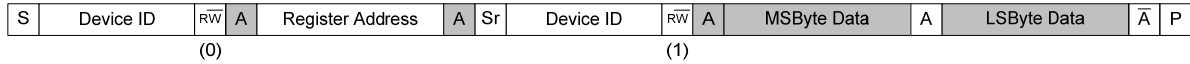

Figure 11 Single Register Read from Specified Address

**SPI CONTROL MODE**

The WM8533 can also be controlled by writing to registers through a SPI control interface. A control word consists of 24 bits. The first bit is the read/write bit ( $R/\overline{W}$ ) which must always be 0, which is followed by 7 address bits ( $A_6$  to  $A_0$ ) that determine which control register is accessed. The remaining 16 bits ( $B_{15}$  to  $B_0$ ) are data bits, corresponding to the 16 bits in each control register.

Volume update registers  $R06h$  and  $R07h$  are unavailable in SPI control mode. To use volume update in software control mode,  $I^2C$  mode must be used.

In SPI mode, every rising edge of SCLK clocks in one data bit from the SDA pin. A rising edge on  $\overline{CS}$  latches in a complete control word consisting of the last 24 bits.

The SPI mode write operation protocol is illustrated in Figure 12.

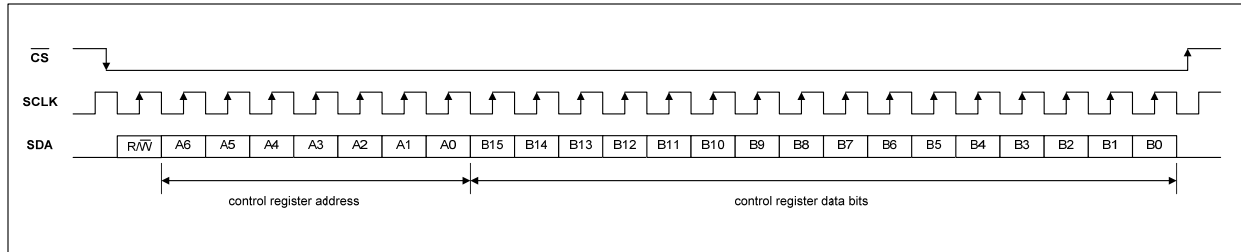

Figure 12 SPI Control Interface – Write operation

In Write operations ( $R/\overline{W}=0$ ), all SDA bits are driven by the controlling device.

**REGISTER RESET**

Any write to register R0 (00h) will reset the WM8533. All register bits are reset to their default values.

**CHIP ID AND REVISION**

Reading from register R0 (00h) returns the Chip ID. Reading from register R1 returns the Chip revision number.

REGISTER ADDRESS	BIT	LABEL	DEFAULT	DESCRIPTION
R0 (00h) DEVICE_ID	15:0	CHIP_ID [15:0]	8523h	<b>Chip ID</b> Writing to this register resets all registers to their default state. Reading from this register will indicate the Chip ID 8523h.
R1 (01h) REVISION	2:0	CHIP_REV [2:0]	001	<b>Chip Revision</b> Indicates the Chip Revision number

**Table 8 Chip ID and Revision Number**

## DIGITAL AUDIO INTERFACE

The digital audio interface is used for inputting audio data to the WM8533. The digital audio interface uses three pins:

- DACDAT: DAC data input
- LRCLK: Left/Right data alignment clock
- BCLK: Bit clock, for synchronisation

### MASTER AND SLAVE MODE OPERATION

The WM8533 digital audio interface can operate as a master or as a slave as shown in Figure 13 and Figure 14.

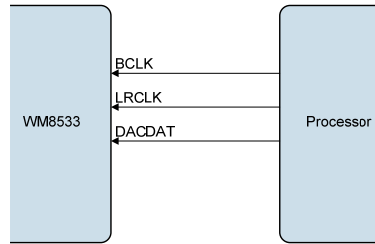

Figure 13 Slave Mode

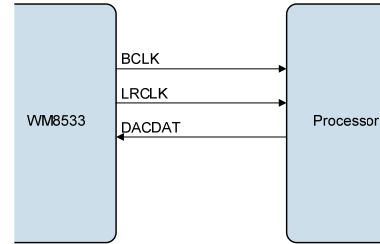

Figure 14 Master Mode

### INTERFACE FORMATS

The WM8533 supports five different audio data formats:

- Left justified
- Right justified
- I2S
- DSP Mode A
- DSP Mode B

PCM operation is supported using the DSP mode. All of these modes are MSB first. They are described in the following sections. Refer to the “Signal Timing Requirements” section for timing information. Refer to Table 10 for interface control format register settings.

### AUDIO DATA FORMATS

In Right Justified mode, the LSB is available on the last rising edge of BCLK before a LRCLK transition. All other bits are transmitted before (MSB first). Depending on word length, BCLK frequency and sample rate, there may be unused BCLK cycles after each LRCLK transition.

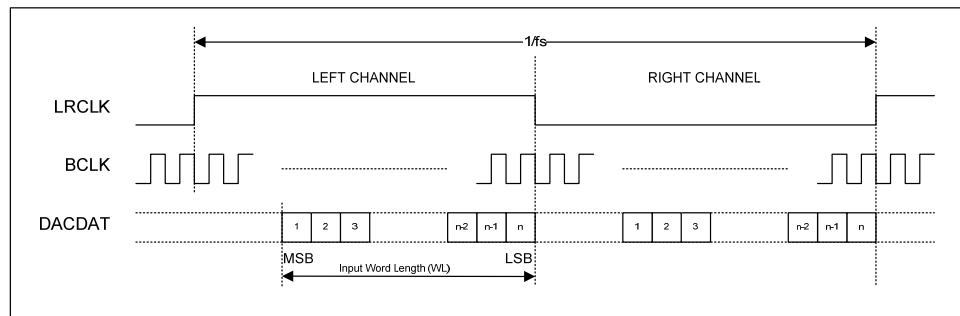

Figure 15 Right Justified Audio Interface (assuming n-bit word length)

In Left Justified mode, the MSB is available on the first rising edge of BCLK following a LRCLK transition. The other bits up to the LSB are then transmitted in order. Depending on word length, BCLK frequency and sample rate, there may be unused BCLK cycles before each LRCLK transition.

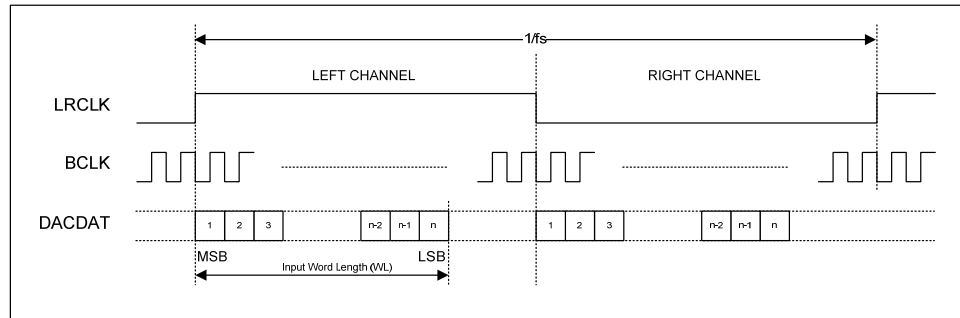

Figure 16 Left Justified Audio Interface (assuming n-bit word length)

In I<sup>2</sup>S mode, the MSB is available on the second rising edge of BCLK following a LRCLK transition. The other bits up to the LSB are then transmitted in order. Depending on word length, BCLK frequency and sample rate, there may be unused BCLK cycles between the LSB of one sample and the MSB of the next.

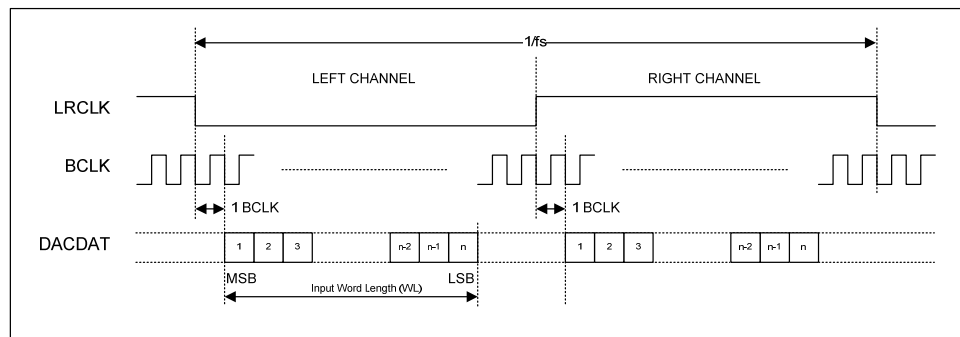

Figure 17 I<sup>2</sup>S Justified Audio Interface (assuming n-bit word length)

In DSP mode, the left channel MSB is available on either the 1<sup>st</sup> (mode B) or 2<sup>nd</sup> (mode A) rising edge of BCLK (selectable by AIF\_LRCLK\_INV) following a rising edge of LRCLK. Right channel data immediately follows left channel data. Depending on word length, BCLK frequency and sample rate, there may be unused BCLK cycles between the LSB of the right channel data and the next sample.

In device master mode, the LRCLK output will resemble the frame pulse shown in Figure 18 and Figure 19. In device slave mode, Figure 20 and Figure 21, it is possible to use any length of frame pulse less than 1/fs, providing the falling edge of the frame pulse occurs greater than one BCLK period before the rising edge of the next frame pulse.

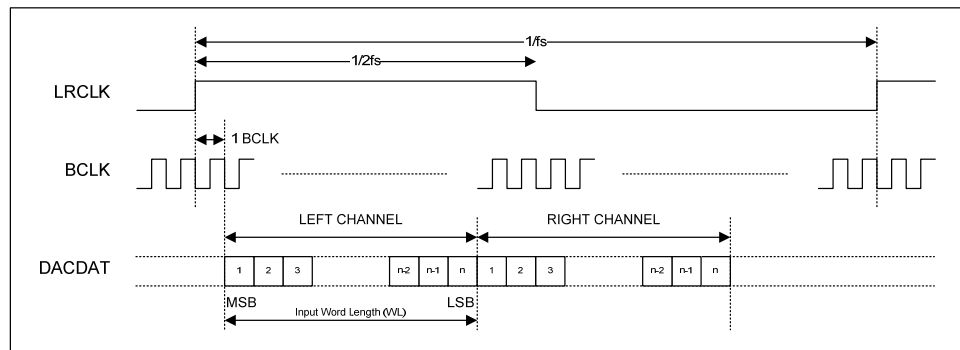

Figure 18 DSP Mode Audio Interface (mode A, AIF\_LRCLK\_INV=0, Master)

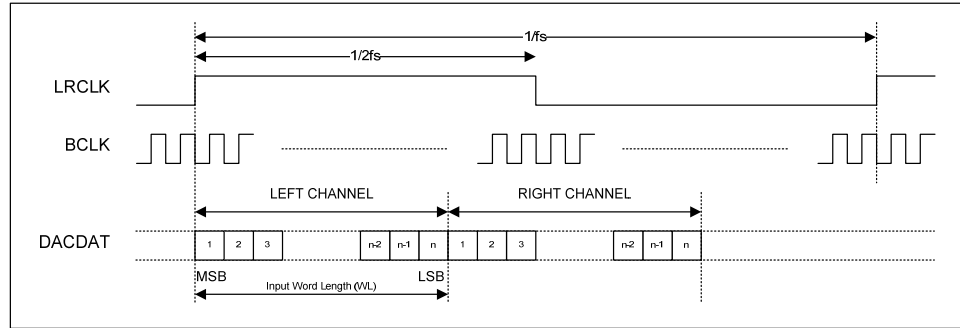

Figure 19 DSP Mode Audio Interface (mode B, AIF\_LRCLK\_INV=1, Master)

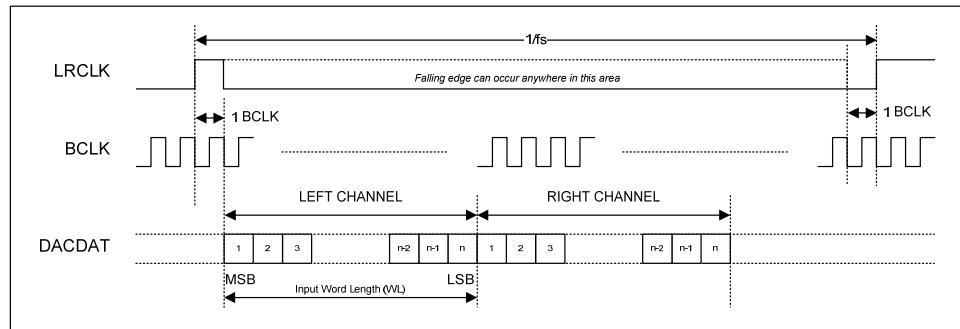

Figure 20 DSP Mode Audio Interface (mode A, AIF\_LRCLK\_INV=0, Slave)

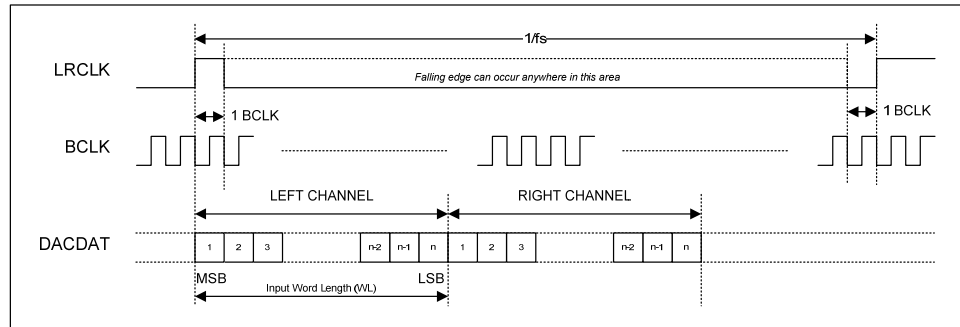

Figure 21 DSP Mode Audio Interface (mode B, AIF\_LRCLK\_INV=1, Slave)

## DIGITAL AUDIO INTERFACE CONTROL

The control of the audio interface in software mode is achieved by register write. Dynamically changing the audio data format may cause erroneous operation and is not recommended.

Digital audio data is transferred to the WM8533 via the digital audio interface. The DAC operates in master or slave mode.

The DAC audio interface requires left/right frame clock (LRCLK) and bit clock (BCLK). These can be supplied externally (slave mode) or they can be generated internally (master mode). Selection of master and slave mode is achieved by setting AIF\_MSTR bit in Register 3.

The frequency of LRCLK in master mode is dependent upon the DAC master clock frequency and the AIF\_SR [2:0] bits. The frequency of BCLK in master mode can be selected by AIF\_BCLKDIV [2:0]. In slave mode, the MCLK to LRCLK ratio can be auto-detected or set manually using the AIF\_SR [2:0] bits.

REGISTER ADDRESS	BIT	LABEL	DEFAULT	DESCRIPTION
R3 (03h) AIF_CTRL1	7	AIF_MSTR	0	<b>Master/Slave Select</b> 0 = Slave 1 = Master
R4 (04h) AIF_CTRL2	5:3	AIF_BCLKD IV [2:0]	000	<b>BCLK Divider Control (Master Mode)</b> 000 = MCLK/4 001 = MCLK/8 010 = 32fs 011 = 64fs 100 = 128fs 101 to 111 = Reserved
	2:0	AIF_SR [2:0]	000	<b>MCLK:LRCLK Ratio</b> 000 = Auto detect 001 = 128fs 010 = 192fs 011 = 256fs 100 = 384fs 101 = 512fs 110 = 768fs 111 = 1152fs

Table 9 DAC Clocking Mode Control

Interface timing is such that the input data and left/right clock are sampled on the rising edge of BCLK. By setting the appropriate BCLK and LRCLK polarity bits, the WM8533 DAC can sample data on the opposite clock edges.

The control of audio interface formats and clock polarities is summarised in Table 10.

REGISTER ADDRESS	BIT	LABEL	DEFAULT	DESCRIPTION
R3 (03h) AIF_CTRL1	6	AIF_LRCLK _INV	0	<b>LRCLK Inversion Control</b> 0 = Normal polarity 1 = Inverted polarity When AIF_FMT [1:0]=11 (DSP Mode): 0 = Mode A (2nd clock) 1 = Mode B (1st clock)
	5	AIF_BCLK_ INV	0	<b>BCLK Inversion Control</b> Slave mode: 0 = use rising edge 1 = use falling edge Master mode: 0 = BCLK normal 1 = BCLK inverted
	4:3	AIF_WL [1:0]	10	<b>Audio Data Word Length</b> 00 = 16 bits 01 = 20 bits 10 = 24 bits 11 = 32 bits
	1:0	AIF_FMT [1:0]	10	<b>Audio Data Interface Format</b> 00 = Right justified 01 = Left justified 10 = I2S format 11 = DSP mode

Table 10 Audio Interface Control

## DIGITAL AUDIO DATA SAMPLING RATES

The external master clock is applied directly to the MCLK input pin. In a system where there are a number of possible sources for the reference clock, it is recommended that the clock source with the lowest jitter be used for the master clock to optimise the performance of the WM8533.

In slave mode the WM8533 has a detection circuit that automatically determines the relationship between the master clock frequency (MCLK) and the sampling rate (LRCLK), to within  $\pm 32$  system clock periods. The MCLK must be synchronised with the LRCLK, although the device is tolerant of phase variations or jitter on the MCLK.

If the device is configured in slave mode using auto-detect or in hardware mode, and during sample rate change the ratio between MCLK and LRCLK varies more than once within 1026 LRCLK periods, then it is recommended that the device be taken into the standby state or the off state before the sample rate change and held in standby until the sample rate change is complete. This will ensure correct operation of the detection circuit on the return to the enabled state. For details on the standby state, please refer to the "Software Control Interface" (software mode, page 15) and "Power Up and Down Control In Hardware Mode" sections of the datasheet (hardware mode, on page 29).

The DAC supports MCLK to LRCLK ratios of 128fs to 1152fs and sampling rates of 8kHz to 192kHz, provided the internal signal processing of the DAC is programmed to operate at the correct rate.

Table 11 shows typical master clock frequencies and sampling rates supported by the WM8533 DAC.

SAMPLE RATE (LRCLK)	MASTER CLOCK (MCLK) FREQUENCY (MHz)						
	128fs	192fs	256fs	384fs	512fs	768fs	1152fs
8kHz	Unavailable	Unavailable	2.048	3.072	4.096	6.144	9.216
32kHz	Unavailable	Unavailable	8.192	12.288	16.384	24.576	36.864
44.1kHz	Unavailable	Unavailable	11.2896	16.9344	22.5792	33.8688	Unavailable
48kHz	Unavailable	Unavailable	12.288	18.432	24.576	36.864	Unavailable
88.2kHz	11.2896	16.9344	22.5792	33.8688	Unavailable	Unavailable	Unavailable
96kHz	12.288	18.432	24.576	36.864	Unavailable	Unavailable	Unavailable
176.4kHz	22.5792	33.8688	Unavailable	Unavailable	Unavailable	Unavailable	Unavailable
192kHz	24.576	36.864	Unavailable	Unavailable	Unavailable	Unavailable	Unavailable

Table 11 MCLK Frequencies and Audio Sample Rates

DAC FEATURES

SYSTEM ENABLE

The WM8533 includes a number of enable and disable mechanisms to allow the device to be powered on and off in a pop-free manner. The SYS\_ENA [1:0] control bits enable the DAC and analogue paths.

REGISTER ADDRESS	BIT	LABEL	DEFAULT	DESCRIPTION
R2 (02h) PSCTRL1	1:0	SYS_ENA [1:0]	00	<b>System Power Control</b> 00 = Off 01 = Power down 10 = Power up (Digital Soft Mute) 11 = Power up (un-muted)

Table 12 System Enable Control

**Note:** MCLK must be present at all times when using the SYS\_ENA [1:0] bits. If MCLK is stopped at any point the device will power down to the 'off' state, but all register settings will remain. Restarting MCLK will start the device internal power sequence and the device will return to the power state set by the SYS\_ENA [1:0] bits.

The power up and power down sequences are summarised in Figure 22. There is no requirement to manually cycle the device through the sequence via register writes, as the device will always automatically step through each stage in the sequence.

Power Up

When SYS\_ENA [1:0]=00, the internal clocks are stopped and all analogue and digital blocks are disabled for maximum power saving. The device starts up in this state in software mode. Setting SYS\_ENA [1:0]=01 enables the internal charge pump and required control circuitry, but the signal path remains powered down. When SYS\_ENA [1:0]=10 all blocks are powered up sequentially and full system configuration is achieved. Once this is complete, the device is ready to pass audio but is muted with a digital soft mute. Setting SYS\_ENA [1:0]=11 releases the digital soft mute and audio playback begins.

Power Down

When SYS\_ENA [1:0]=11 the device is powered up and passing audio. Changing SYS\_ENA [1:0]=10 applies a digital soft mute to the output, with attenuation of 100dB on the input signal. Setting SYS\_ENA [1:0]=01 sequentially powers down all circuit blocks but leaves the charge pump and required control circuitry enabled. This state is equivalent to the Hardware Mode mute state, and will give 120dB attenuation on the input signal. This can be considered the low-power standby state. Finally, setting SYS\_ENA [1:0]=00 will disable all circuit blocks including the charge pump, and full system initialisation will be required to restart the device.

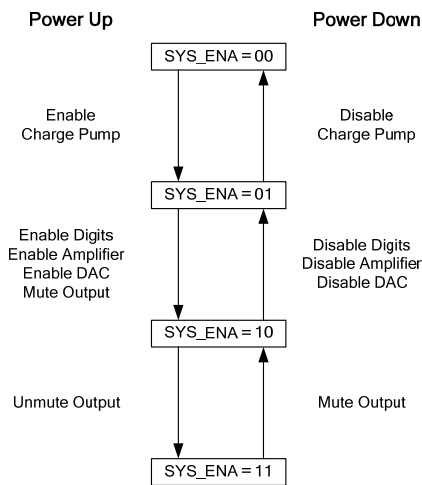

Figure 22 SYS\_ENA [1:0] Power Up and Down Sequences

### DIGITAL VOLUME CONTROL

The WM8533 DAC includes digital volume control, allowing the digital gain to be adjusted between -100dB and +12dB in 0.25dB steps. Volume update bits allow the user to write both left and right channel volume changes before the volume is updated.

Note that digital volume control is only available in I<sup>2</sup>C mode.

REGISTER ADDRESS	BIT	LABEL	DEFAULT	DESCRIPTION
R6 (06h) DAC_GAINL	9	DACL_VU	0	<b>DAC Digital Volume Update</b> 0 = Latch DAC volume setting into Register Map but do not update volume 1 = Latch DAC volume setting into Register Map and update left and right channels simultaneously
R7 (07h) DAC_GAINR	9	DACR_VU	0	
R6 (06h) DAC_GAINL	8:0	DACL_VOL [8:0]	190h	<b>DAC Digital Volume</b> 000h = -100dB 001h = -99.75dB 002h = -99.5dB ...0.25dB steps 190h = 0dB ...0.25dB steps 1BEh = +11.75dB 1BFh to 1FFh = +12dB
R7 (07h) DAC_GAINR	8:0	DACR_VOL [8:0]	190h	

Table 13 DAC Digital Volume Control

### VOLUME CHANGE MODES

Volume can be adjusted by step change (either using zero cross or not) or by soft ramp. The volume change mode is controlled by the DAC\_VOL\_DOWN\_RAMP and DAC\_VOL\_UP\_RAMP bits in R5:

REGISTER ADDRESS	BIT	LABEL	DEFAULT	DESCRIPTION
R5 (05h) DAC_CTRL3	1	DAC_VOL_UP_RAMP	0	<b>DAC Digital Volume Increase Control</b> 0 = Apply volume increases instantly (step) 1 = Ramp volume increases
	0	DAC_VOL_DOWN_RAMP	1	<b>DAC Digital Volume Decrease Control</b> 0 = Apply volume decreases instantly (step) 1 = Ramp volume decreases

Table 14 Volume Ramp Control

The effect of the volume ramp is illustrated in Figure 23.

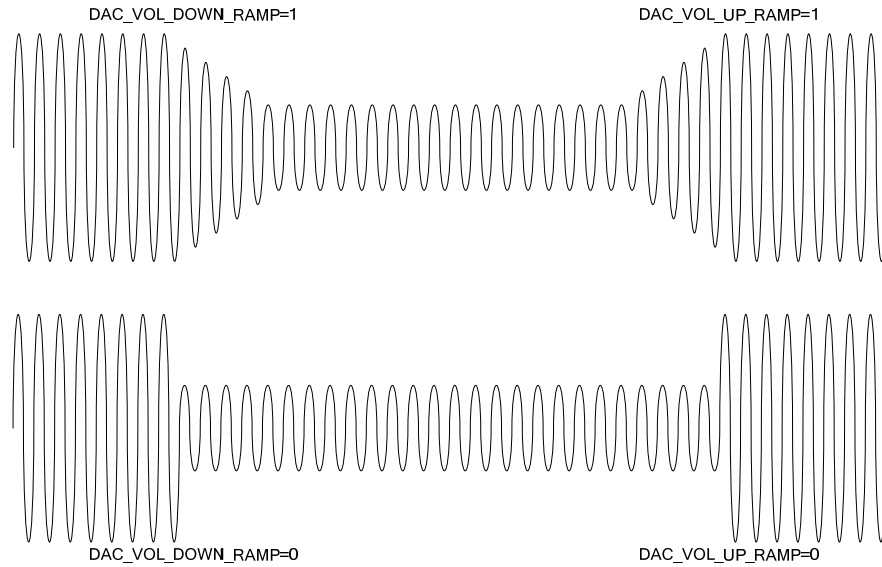

**Figure 23 Volume Ramp Functionality**

**Ramp Volume Changes**

If ramp volume changes are selected, the ramp rate is dependent upon the sampling rate. The ramp rates for common audio sample rates are shown in Table 15.

SAMPLE RATE FOR DAC (kHz)	GAIN RAMP RATE (ms/dB)
8	1
32	0.25
44.1	0.18
48	0.17
88.2	0.1
96	0.08
176.4	0.05
192	0.04

**Table 15 Volume Ramp Rate**

For example, when using a sample rate of 48kHz, the time taken for a volume change from an initial setting of 0dB to -20dB is calculated as follows:

$$\text{Volume Change (dB)} \times \text{Volume Ramp Rate (ms/dB)} = 20 \times 0.17 = 3.4\text{ms}$$

Zero cross is not used when ramping. The volume level in the DAC is set by the user in 0.25dB increments, but during the volume ramp increments of 0.125dB are actually used. This step size is inaudible and means there is no requirement to wait until a zero crossing occurs. Another benefit of not using zero cross when ramping is that predictable ramp times are produced – there is no signal dependency on the ramp time.

### Step Volume Changes and Zero Cross

The step volume control includes optional zero cross functionality. When zero cross is enabled, by setting DAC\_ZC=1, volume changes are not applied until the signal crosses zero so no discontinuity is seen in the output signal. Zero cross helps to prevent pop and click noise when changing volume settings and is therefore recommended if using step volume changes.

The zero cross function includes a timeout which forces volume changes if a zero cross event does not occur. The timeout period is 14400 samples, equivalent to 300ms at 48kHz sample rate.

REGISTER ADDRESS	BIT	LABEL	DEFAULT	DESCRIPTION
R5 (05h) DAC_CTRL3	4	DAC_ZC	0	<b>Zero Cross Enable</b> 0 = Do not use zero cross 1 = Use zero cross

**Table 16 Zero Cross Control**

Table 17 gives a summary of the volume mode settings and their effect.

DAC_VOL_UP_RAMP	DAC_VOL_DOWN_RAMP	DAC_ZC	VOLUME CHANGE UP	VOLUME CHANGE DOWN
0	0	0	Step, no zero cross	Step, no zero cross
0	1	0	Step, no zero cross	Ramp
1	0	0	Ramp	Step, no zero cross
1	1	0	Ramp	Ramp
0	0	1	Step, use zero cross	Step, use zero cross
0	1	1	Step, use zero cross	Ramp
1	0	1	Ramp	Step, use zero cross
1	1	1	Ramp	Ramp

**Table 17 Volume Change Summary**

### MUTE

A digital mute can be applied to left and right channels independently.

REGISTER ADDRESS	BIT	LABEL	DEFAULT	DESCRIPTION
R5 (05h) DAC_CTRL3	3	DACR_MUTE	0	<b>Right DAC Mute</b> 0 = Normal operation 1 = Mute
	2	DACL_MUTE	0	<b>Left DAC Mute</b> 0 = Normal operation 1 = Mute

**Table 18 DAC Mute Control**

The DAC mute function in software mode is controlled by the register settings DAC\_VOL\_UP\_RAMP, DAC\_VOL\_DOWN\_RAMP and DAC\_ZC as described in Table 17.

**DIGITAL MONOMIX CONTROL**

The DAC can be set to output a range of mono and stereo options using DAC\_OP\_MUX [1:0].

REGISTER ADDRESS	BIT	LABEL	DEFAULT	DESCRIPTION
R4 (04h) AIF_CTRL2	7:6	DAC_OP_MUX [1:0]	00	<b>DAC Digital Monomix</b> 00 = Stereo (Normal Operation) 01 = Mono (Left data to DACR) 10 = Mono (Right data to DACL) 11 = Digital Monomix, (L+R)/2

**Table 19 Digital Monomix Control**

**DE-EMPHASIS**

A digital de-emphasis filter may be applied to the DAC output when the sampling frequency is 44.1kHz. Operation at 48kHz and 32kHz is also possible, but with an increase in the error from the ideal response. Details of the de-emphasis filter characteristic for 32kHz, 44.1kHz and 48kHz can be seen in Figure 29 to Figure 34.

REGISTER ADDRESS	BIT	LABEL	DEFAULT	DESCRIPTION
R3 (03h) AIF_CTRL1	8	DAC_DEEMP	0	<b>DAC De-emphasis</b> 0 = No de-emphasis 1 = Apply de-emphasis

**Table 20 De-emphasis Control**

**HARDWARE CONTROL INTERFACE**

The WM8533 can be controlled in hardware mode or in software modes. In hardware mode, the device is configured according to logic levels applied to hardware pins.

Hardware control mode is selected by leaving CIFMODE pin open-circuit (high-impedance). When hardware mode is selected, the associated multi-function control pins are defined as described in Table 21.

PIN NAME	DESCRIPTION															
AIFMODE0 / AIFMODE1	<table border="1"> <thead> <tr> <th>AIFMODE1</th> <th>AIFMODE0</th> <th>FORMAT</th> </tr> </thead> <tbody> <tr> <td>0</td> <td>0</td> <td>24-bit Left Justified</td> </tr> <tr> <td>0</td> <td>1</td> <td>24-bit I<sup>2</sup>S</td> </tr> <tr> <td>1</td> <td>0</td> <td>16-bit Right Justified</td> </tr> <tr> <td>1</td> <td>1</td> <td>24-bit Right Justified</td> </tr> </tbody> </table>	AIFMODE1	AIFMODE0	FORMAT	0	0	24-bit Left Justified	0	1	24-bit I <sup>2</sup> S	1	0	16-bit Right Justified	1	1	24-bit Right Justified
AIFMODE1	AIFMODE0	FORMAT														
0	0	24-bit Left Justified														
0	1	24-bit I <sup>2</sup> S														
1	0	16-bit Right Justified														
1	1	24-bit Right Justified														
MUTE	<b>Mute Control</b> 0 = Mute 1 = Normal operation															
CIFMODE	<b>Control Interface Mode</b> 0 = I <sup>2</sup> C Mode 1 = SPI Mode Z = Hardware Mode															

**Table 21 Hardware Control Pin Configuration**

**MUTE**

In hardware mode, the  $\overline{\text{MUTE}}$  pin controls the DAC mute to both left and right channels. When the mute is asserted a softmute is applied to ramp the signal down, with the ramp rate related to the sample rate as defined in Table 15 on page 26. When the mute is de-asserted the DAC output returns to normal in one step.

### POWER UP AND DOWN CONTROL IN HARDWARE MODE

In hardware mode the MCLK, BCLK and  $\overline{\text{MUTE}}$  pins are monitored to control how the device powers up or down, and this is summarised in Figure 24 below.

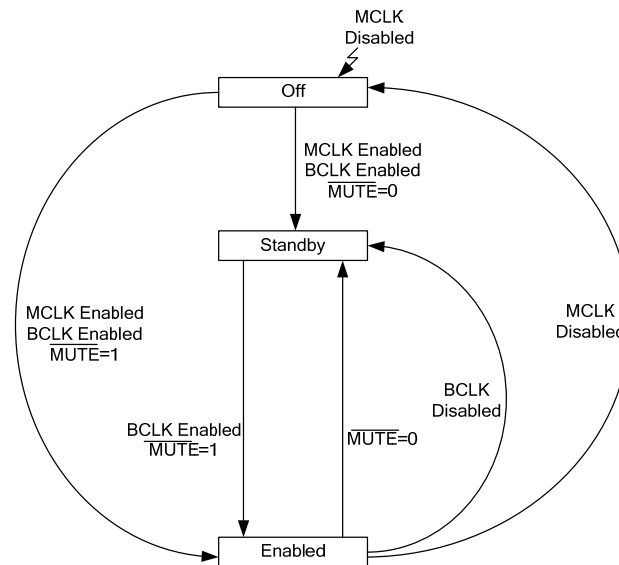

**Figure 24 Hardware Power Sequence Diagram**

#### Off to Enable

To power up the device to enabled, start MCLK and BCLK and set  $\overline{\text{MUTE}} = 1$ .

#### Off to Standby

To power up the device to standby, start MCLK and BCLK and set  $\overline{\text{MUTE}} = 0$ . Once the device is in standby mode, BCLK can be disabled and the device will remain in standby mode.

#### Standby to Enable

To transition from the standby state to the enabled state, set the  $\overline{\text{MUTE}}$  pin to logic 1 and start BCLK.

#### Enable to Standby

To power down to a standby state leaving the charge pump running, either set the  $\overline{\text{MUTE}}$  pin to logic 0 or stop BCLK. MCLK must continue to run in these situations. The device will automatically mute and power down quietly in either case.

Note: It is recommended that the device is placed in standby mode before sample rate change if the sample rate changes more than once in 1026 LRCLK periods, as detailed in "Digital Audio Data Sampling Rates" on page 23.

#### Enable to Off

To power down the device completely, stop MCLK at any time. It is recommended that the device is placed into standby mode as described above before stopping MCLK to allow a quiet shutdown.

For the timing of the off state to enabled state transition (power on to audio out timing), and the enabled state to standby state transition (the shutdown timing), please refer to WTN0302.

**REGISTER MAP**

The complete register map is shown below. The detailed description can be found in the relevant text of the device description. The WM8533 can be configured using the Control Interface. All unused bits should be set to '0' and access to unlisted registers should be avoided.

REG	NAME	15	14	13	12	11	10	9	8	7	6	5	4	3	2	1	0	DEFAULT
R0 (0h)	DEVICE_ID / SW RESET	CHIP_ID [15:0]																8523h
R1 (1h)	REVISION	0	0	0	0	0	0	0	0	0	0	0	0	0	CHIP_REV [2:0]		0001h	
R2 (2h)	PSCTRL1	0	0	0	0	0	0	0	0	0	0	0	0	0	SYS_ENA [1:0]		0000h	
R3 (3h)	AIF_CTRL1	0	0	0	0	0	0	0	DAC_DEEMP	AIF_MSTR	AIF_LRCLK_INV	AIF_BCLK_INV	AIF_WL [1:0]		0	AIF_FMT [1:0]		1812h
R4 (4h)	AIF_CTRL2	0	0	0	0	0	0	0	0	DAC_OP_MUX [1:0]		AIF_BCLKDIV [2:0]		AIF_SR [2:0]			0000h	
R5 (5h)	DAC_CTRL3	0	0	0	0	0	0	0	0	0	0	DAC_ZC	DACR_MUTE	DACL_MUTE	DAC_VOL_UP_RAMP	DAC_VOL_DOWN_RAMP	0001h	
R6 (6h)	DAC_GAINL	0	0	0	0	0	0	DACL_VU	DACL_VOL [8:0]									0190h
R7 (7h)	DAC_GAINR	0	0	0	0	0	0	DACR_VU	DACR_VOL [8:0]									0190h

**Table 22 Register Map**

**REGISTER BITS BY ADDRESS**

REGISTER ADDRESS	BIT	LABEL	DEFAULT	DESCRIPTION	REFER TO
R0 (00h) DEVICE_ID/ SW RESET	15:0	CHIP_ID [15:0]	1000_0101_0010_0011	<b>Chip ID</b> Writing to this register resets all registers to their default state. Reading from this register will indicate the Chip ID 8523h.	Page 18

**Register 00h** DEVICE\_ID / SW RESET

REGISTER ADDRESS	BIT	LABEL	DEFAULT	DESCRIPTION	REFER TO
R1 (01h) REVISION	2:0	CHIP_REV [2:0]	001	<b>Chip Revision</b> Indicates the Chip Revision number	Page 18

**Register 01h** REVISION

REGISTER ADDRESS	BIT	LABEL	DEFAULT	DESCRIPTION	REFER TO
R2 (02h) PSCTRL1	1:0	SYS_ENA [1:0]	00	<b>System Power Control</b> 00 = Off 01 = Power down 10 = Power up (muted) 11 = Power up (unmuted)	Page 24

**Register 02h** PSCTRL1

REGISTER ADDRESS	BIT	LABEL	DEFAULT	DESCRIPTION	REFER TO
R3 (03h) AIF_CTRL1	8	DAC_DEEMP	0	<b>DAC De-emphasis Control</b> 0 = No de-emphasis 1 = De-emphasis enabled	Page 28
	7	AIF_MSTR	0	<b>Master/Slave Select</b> 0 = Slave mode 1 = Master mode	Page 21
	6	AIF_LRCLK_INV	0	<b>LRCLK Inversion Control</b> 0 = Normal polarity 1 = Inverted polarity When AIF_FMT [1:0]=11 (DSP Mode): 0 = Mode A (2nd clock) 1 = Mode B (1st clock)	Page 21
	5	AIF_BCLK_INV	0	<b>BCLK Inversion Control</b> Slave mode: 0 = Use rising edge 1 = Use falling edge Master mode: 0 = BCLK normal 1 = BCLK inverted	Page 21
	4:3	AIF_WL [1:0]	10	<b>Audio Data Word Length</b> 00 = 16 bits 01 = 20 bits 10 = 24 bits 11 = 32 bits	Page 21
	2	Reserved	0	Reserved	
	2:0	AIF_FMT [1:0]	10	<b>Audio Data Interface Format</b> 00 = Right justified 01 = Left justified 10 = I <sup>2</sup> S format 11 = DSP mode	Page 21

Register 03h AIF\_CTRL1

REGISTER ADDRESS	BIT	LABEL	DEFAULT	DESCRIPTION	REFER TO
R4 (04h) AIF_CTRL2	7:6	DAC_OP_MUX [1:0]	00	<b>Digital Monomix Control</b> 00 = Stereo (Normal operation) 01 = Mono (Left data to DACR) 10 = Mono (Right data to DACL) 11 = Digital Monomix, (L+R)/2	Page 28
	5:3	AIF_BCLKDIV [2:0]	000	<b>BCLK Divider Control (Master Mode)</b> 000 = MCLK/4 001 = MCLK/8 010 = 32fs 011 = 64fs 100 = 128fs 101 to 111 = Reserved	Page 21
	2:0	AIF_SR [2:0]	000	<b>MCLK:LRCLK Ratio</b> 000 = Auto detect 001 = 128fs 010 = 192fs 011 = 256fs 100 = 384fs 101 = 512fs 110 = 768fs 111 = 1152fs	Page 21

Register 04h AIF\_CTRL2

REGISTER ADDRESS	BIT	LABEL	DEFAULT	DESCRIPTION	REFER TO
R5 (05h) DAC_CTRL3	4	DAC_ZC	0	<b>Zero Cross Enable</b> 0 = Do not use zero cross 1 = Use zero cross	Page 25
	3	DACR_MUTE	0	<b>Right DAC Mute</b> 0 = Normal operation 1 = Mute	Page 27
	2	DACL_MUTE	0	<b>Left DAC Mute</b> 0 = Normal operation 1 = Mute	Page 27
	1	DAC_VOL_ UP_RAMP	0	<b>DAC Digital Volume Increase Control</b> 0 = Apply volume increases instantly (step) 1 = Ramp volume increases	Page 25
	0	DAC_VOL_ DOWN_RAMP	1	<b>DAC Digital Volume Decrease Control</b> 0 = Apply volume decreases instantly (step) 1 = Ramp volume decreases	Page 25

Register 05h DAC\_CTRL3

REGISTER ADDRESS	BIT	LABEL	DEFAULT	DESCRIPTION	REFER TO
R6 (06h) DAC_GAINL	9	DACL_VU	0	<b>Left DAC Digital Volume Update</b> 0 = Latch Left DAC volume setting into register map but do not update volume 1 = Latch Left DAC volume setting into register map and update left and right channels simultaneously	Page 25
	8:0	DACL_VOL [8:0]	1_1001_0000	<b>Left DAC Digital Volume Control</b> 000h = -100dB 001h = -99.75dB 002h = -99.5dB ...0.25dB steps 190h = 0dB ...0.25dB steps 1BEh = +11.75dB 1BFh to 1FFh = +12dB	Page 25

**Register 06h DAC\_GAINL**

REGISTER ADDRESS	BIT	LABEL	DEFAULT	DESCRIPTION	REFER TO
R7 (07h) DAC_GAINR	9	DACR_VU	0	<b>Right DAC Digital Volume Update</b> 0 = Latch Right DAC volume setting into register map but do not update volume 1 = Latch Right DAC volume setting into register map and update left and right channels simultaneously	Page 25
	8:0	DACR_VOL [8:0]	1_1001_0000	<b>Right DAC Digital Volume Control</b> 000h = -100dB 001h = -99.75dB 002h = -99.5dB ...0.25dB steps 190h = 0dB ...0.25dB steps 1BEh = +11.75dB 1BFh to 1FFh = +12dB	Page 25

**Register 07h DAC\_GAINR**

**DIGITAL FILTER CHARACTERISTICS**

PARAMETER	TEST CONDITIONS	MIN	TYP	MAX	UNIT
<b>DAC Filter – 256fs to 1152fs</b>					
Passband	$\pm 0.1\text{dB}$			0.454fs	
Passband Ripple				0.1	dB
Stopband		0.546fs			
Stopband attenuation	$f > 0.546\text{fs}$	-50			dB
Group Delay			14.5fs		
<b>DAC Filter – 128fs and 192fs</b>					
Passband	$\pm 0.1\text{dB}$			0.247fs	
Passband Ripple				0.1	dB
Stopband		0.753fs			
Stopband attenuation	$f > 0.753\text{fs}$	-50			dB
Group Delay			6.5fs		

**TERMINOLOGY**

1. Stop Band Attenuation (dB) – the degree to which the frequency spectrum is attenuated (outside audio band)
2. Pass-band Ripple – any variation of the frequency response in the pass-band region

**DAC FILTER RESPONSES**

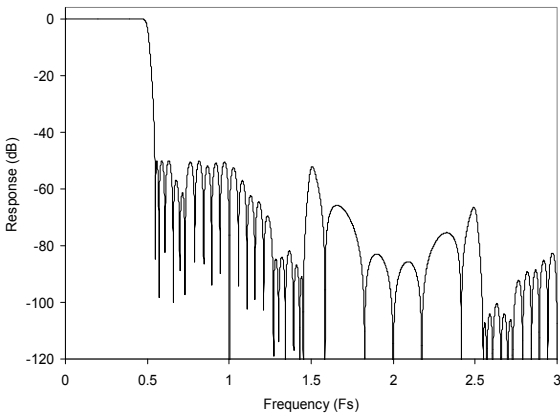

**Figure 25 DAC Digital Filter Frequency Response – 256fs to 1152fs Clock Modes**

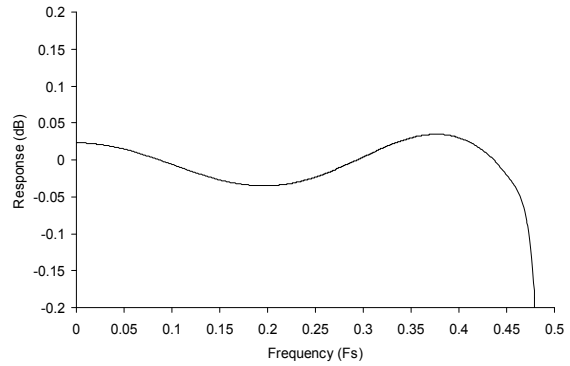

**Figure 26 DAC Digital Filter Ripple – 256fs to 1152fs Clock Modes**

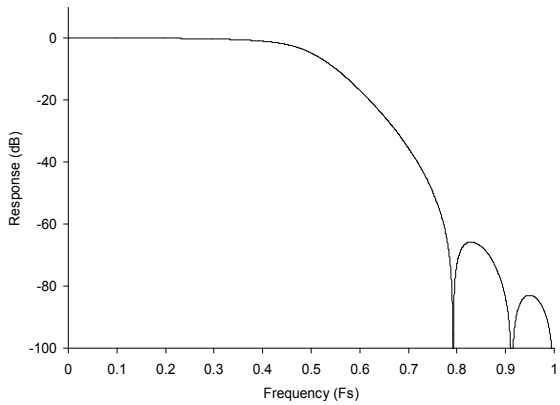

**Figure 27 DAC Digital Filter Frequency Response – 128fs and 192fs Clock Modes**

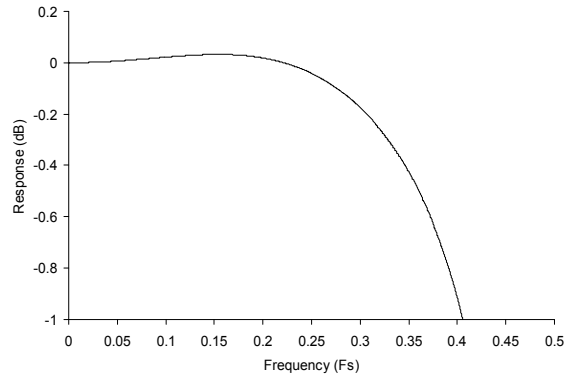

**Figure 28 DAC Digital Filter Ripple – 128fs to 192fs Clock Modes**

### DIGITAL DE-EMPHASIS CHARACTERISTICS

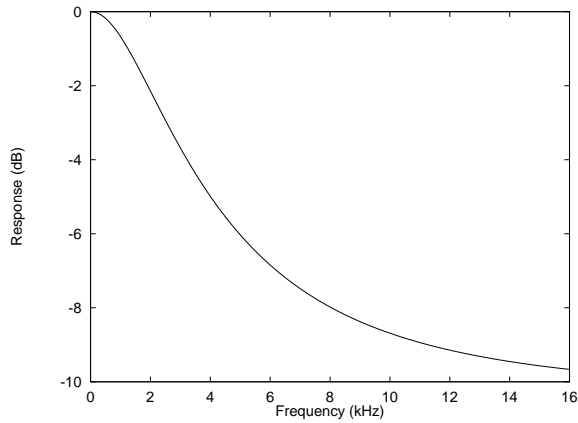

Figure 29 De-Emphasis Frequency Response (32kHz)

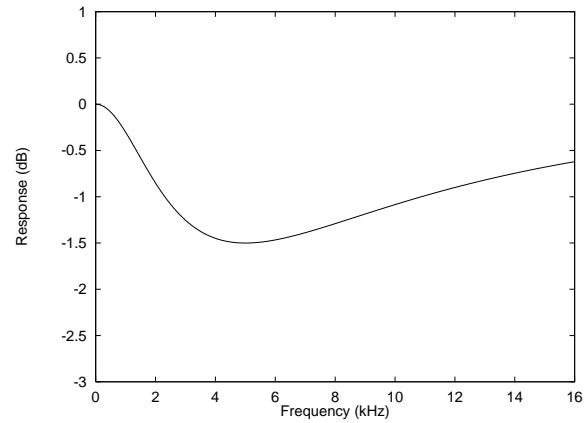

Figure 30 De-Emphasis Error (32kHz)

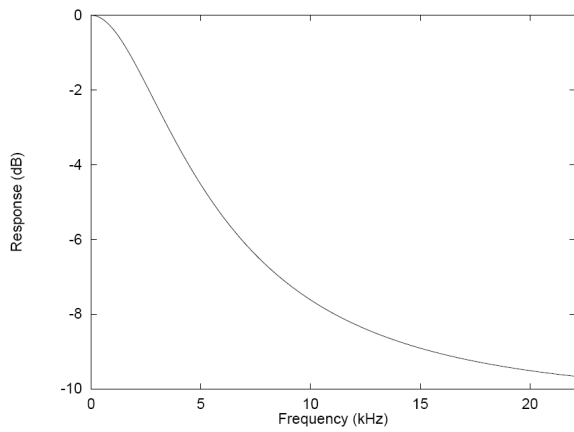

Figure 31 De-Emphasis Frequency Response (44.1kHz)

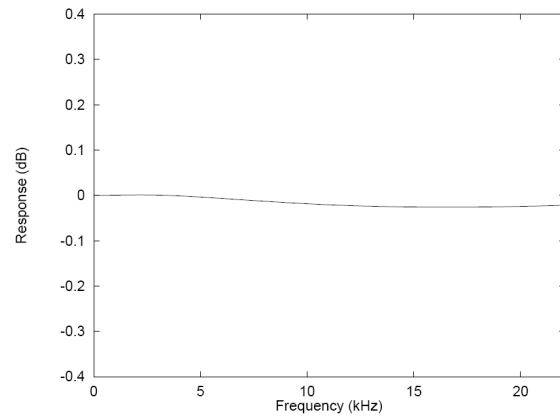

Figure 32 De-Emphasis Error (44.1kHz)

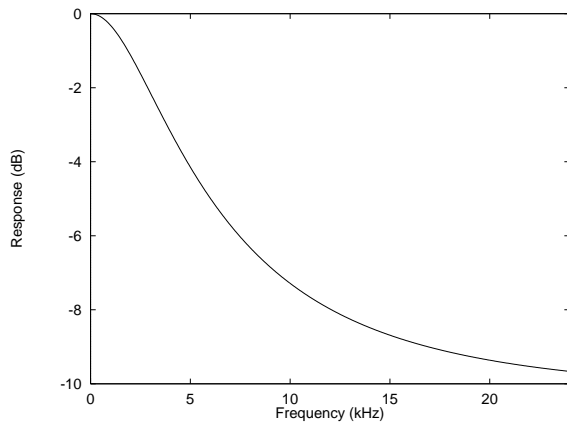

Figure 33 De-Emphasis Frequency Response (48kHz)

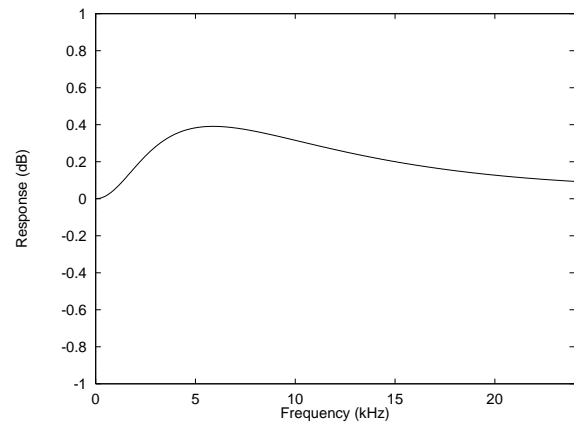

Figure 34 De-Emphasis Error (48kHz)

RECOMMENDED EXTERNAL COMPONENTS

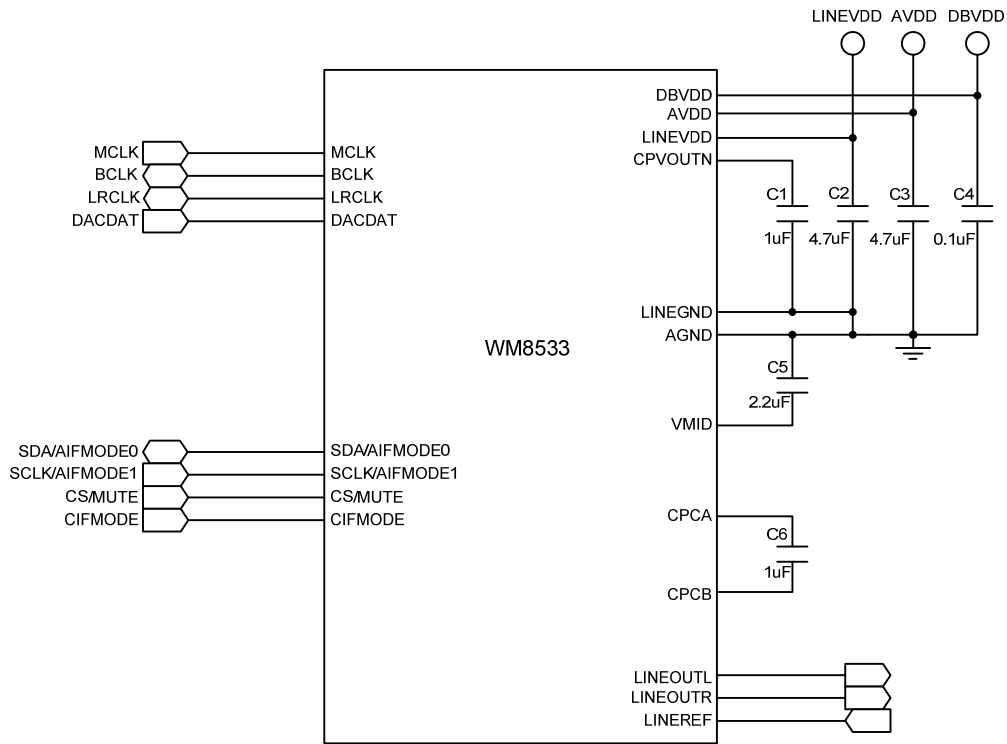
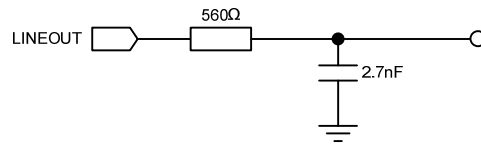

Figure 35 Recommended External Components

Notes:

1. Wolfson recommend using a single, common ground plane. Where this is not possible, care should be taken to optimise split ground configuration for audio performance.
2. Charge Pump fly-back capacitor C5 should be placed as close to WM8533 as possible, followed by Charge Pump decoupling capacitor C1, then LINEVDD and VMID decoupling capacitors.
3. Capacitor types should be chosen carefully. Capacitors with very low ESR are recommended for optimum performance.

## RECOMMENDED ANALOGUE LOW PASS FILTER



**Figure 36 Recommended Analogue Low Pass Filter (one channel shown)**

An external single-pole RC filter is recommended if the device is driving a wideband amplifier. Other filter architectures may provide equally good results.

The filter shown in Figure 36 has a -3dB cut-off at 105.26kHz and a droop of 0.15dB at 20kHz. The typical output from the WM8533 is 2.1Vrms – when a 10kΩ load is placed at the output of this recommended filter the amplitude across this load is 1.99Vrms.

## RELEVANT APPLICATION NOTES

The following application notes, available from [www.wolfsonmicro.com](http://www.wolfsonmicro.com), may provide additional guidance for use of the WM8533.

### DEVICE PERFORMANCE:

WAN0129 – Decoupling and Layout Methodology for Wolfson DACs, ADCs and CODECs

WAN0144 – Using Wolfson Audio DACs and CODECs with Noisy Supplies

WTN0302 - WM8524 Recommended Power Sequence and Timing (for hardware mode)

### GENERAL:

WAN0108 – Moisture Sensitivity Classification and Plastic IC Packaging

WAN0109 – ESD Damage in Integrated Circuits: Causes and Prevention

WAN0158 – Lead-Free Solder Profiles for Lead-Free Components

WAN0161 – Electronic End-Product Design for ESD

PACKAGE DIMENSIONS

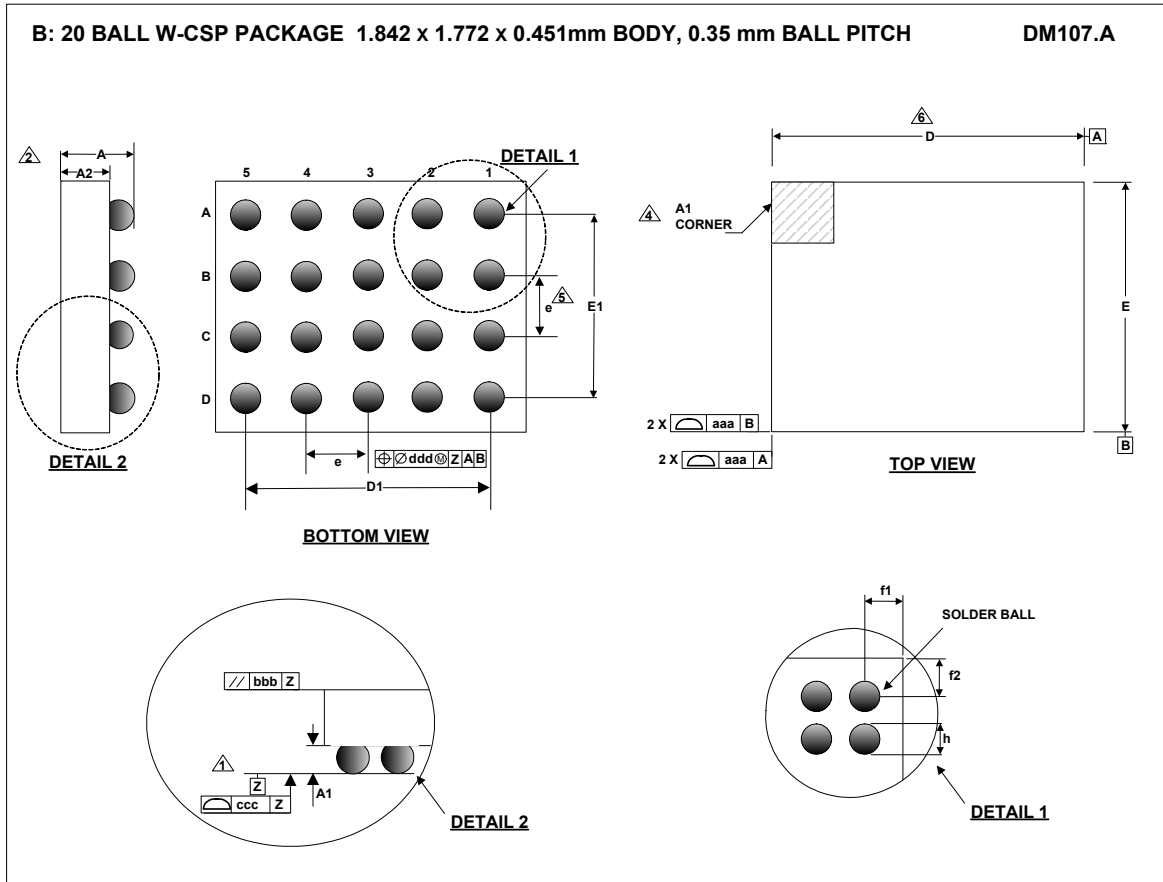

Symbols	Dimensions (mm)			NOTE
	MIN	NOM	MAX	
<b>A</b>	0.421	0.451	0.481	
<b>A1</b>	0.146	0.172	0.198	
<b>A2</b>	0.266	0.279	0.292	
<b>D</b>	1.817	1.842	1.867	
<b>D1</b>		1.400 BSC		
<b>E</b>	1.747	1.772	1.797	
<b>E1</b>		1.050 BSC		
<b>e</b>		0.350 BSC		5
<b>f1</b>	0.2085	0.221		
<b>f2</b>	0.3485	0.361		
<b>h</b>	0.175	0.205	0.235	
<b>aaa</b>		0.025		
<b>bbb</b>		0.060		
<b>ccc</b>		0.030		
<b>ddd</b>		0.015		

- NOTES:
1. PRIMARY DATUM -Z- AND SEATING PLANE ARE DEFINED BY THE SPHERICAL CROWNS OF THE SOLDER BALLS.
  2. THIS DIMENSION INCLUDES STAND-OFF HEIGHT 'A1'.
  3. A1 CORNER IS IDENTIFIED BY INK/LASER MARK ON TOP PACKAGE.
  4. BILATERAL TOLERANCE ZONE IS APPLIED TO EACH SIDE OF THE PACKAGE BODY.
  5. 'e' REPRESENTS THE BASIC SOLDER BALL GRID PITCH.
  6. THIS DRAWING IS SUBJECT TO CHANGE WITHOUT NOTICE.
  7. FOLLOWS JEDEC DESIGN GUIDE MO-211-C.

## IMPORTANT NOTICE

Wolfson Microelectronics plc ("Wolfson") products and services are sold subject to Wolfson's terms and conditions of sale, delivery and payment supplied at the time of order acknowledgement.

Wolfson warrants performance of its products to the specifications in effect at the date of shipment. Wolfson reserves the right to make changes to its products and specifications or to discontinue any product or service without notice. Customers should therefore obtain the latest version of relevant information from Wolfson to verify that the information is current.

Testing and other quality control techniques are utilised to the extent Wolfson deems necessary to support its warranty. Specific testing of all parameters of each device is not necessarily performed unless required by law or regulation.

In order to minimise risks associated with customer applications, the customer must use adequate design and operating safeguards to minimise inherent or procedural hazards. Wolfson is not liable for applications assistance or customer product design. The customer is solely responsible for its selection and use of Wolfson products. Wolfson is not liable for such selection or use nor for use of any circuitry other than circuitry entirely embodied in a Wolfson product.

Wolfson's products are not intended for use in life support systems, appliances, nuclear systems or systems where malfunction can reasonably be expected to result in personal injury, death or severe property or environmental damage. Any use of products by the customer for such purposes is at the customer's own risk.

Wolfson does not grant any licence (express or implied) under any patent right, copyright, mask work right or other intellectual property right of Wolfson covering or relating to any combination, machine, or process in which its products or services might be or are used. Any provision or publication of any third party's products or services does not constitute Wolfson's approval, licence, warranty or endorsement thereof. Any third party trade marks contained in this document belong to the respective third party owner.

Reproduction of information from Wolfson datasheets is permissible only if reproduction is without alteration and is accompanied by all associated copyright, proprietary and other notices (including this notice) and conditions. Wolfson is not liable for any unauthorised alteration of such information or for any reliance placed thereon.

Any representations made, warranties given, and/or liabilities accepted by any person which differ from those contained in this datasheet or in Wolfson's standard terms and conditions of sale, delivery and payment are made, given and/or accepted at that person's own risk. Wolfson is not liable for any such representations, warranties or liabilities or for any reliance placed thereon by any person.

## ADDRESS

Wolfson Microelectronics plc  
Westfield House  
26 Westfield Road  
Edinburgh  
EH11 2QB

Tel :: +44 (0)131 272 7000

Fax :: +44 (0)131 272 7001

Email :: [sales@wolfsonmicro.com](mailto:sales@wolfsonmicro.com)

## Looking for pricing, stock, or lifecycle information?

Click below to explore more details on WIN SOURCE:

 [View WM8533ECSN/R on WIN SOURCE](#)

 [Cirrus Logic Inc. Information](#)

## Optimize Your Supply Chain with WIN SOURCE Solutions

-  Global Sourcing Solution
-  Obsolete Management
-  Cost Control Management
-  Shortage Management
-  Alternative Solution
-  Excess Inventory Management