

74VHC4051, 8-Channel Analog Multiplexer 74VHC4052, Dual 4-Channel Analog Multiplexer 74VHC4053, Triple 2-Channel Analog Multiplexer

Features

- Wide analog input voltage range: $\pm 6V$
- Low "ON" resistance: 50 Typ. ($V_{CC}-V_{EE} = 4.5V$)
- 30 Typ. ($V_{CC}-V_{EE} = 9V$)
- Logic level translation to enable 5V logic with $\pm 5V$ analog signals
- Low quiescent current: 80 μA maximum
- Matched switch characteristic
- Pin and function compatible with the 74HC4051/ 4052/4053

General Description

These multiplexers are digitally controlled analog switches implemented in advanced silicon-gate CMOS technology. These switches have low "ON" resistance and low "OFF" leakages. They are bidirectional switches, thus any analog input may be used as an output and vice-versa. Also these switches contain linearization circuitry which lowers the "ON" resistance and increases switch linearity. These devices allow control of up to $\pm 6V$ (peak) analog signals with digital control signals of 0 to 6V. Three supply pins are provided for V_{CC} , ground, and V_{EE} . This enables the connection of 0–5V logic signals when $V_{CC} = 5V$ and an analog input range of $\pm 5V$ when $V_{EE} = 5V$. All three devices also have an inhibit control which when high will disable all switches to their off state. All analog inputs and outputs and digital inputs are protected from electrostatic damage by diodes to V_{CC} and ground.

VHC4051: This device connects together the outputs of 8 switches, thus achieving an 8 channel Multiplexer. The binary code placed on the A, B, and C select lines determines which one of the eight switches is "ON", and connects one of the eight inputs to the common output.

VHC4052: This device connects together the outputs of 4 switches in two sets, thus achieving a pair of 4-channel multiplexers. The binary code placed on the A, and B select lines determine which switch in each 4 channel section is "ON", connecting one of the four inputs in each section to its common output. This enables the implementation of a 4-channel differential multiplexer.

VHC4053: This device contains 6 switches whose outputs are connected together in pairs, thus implementing a triple 2 channel multiplexer, or the equivalent of 3 single-pole-double throw configurations. Each of the A, B, or C select lines independently controls one pair of switches, selecting one of the two switches to be "ON".

Ordering Information

Order Number	Package Number	Package Description
74VHC4051M	M16A	16-Lead Small Outline Integrated Circuit (SOIC), JEDEC MS-012, 0.150" Narrow
74VHC4051WM	M16B	16-Lead Small Outline Integrated Circuit (SOIC), JEDEC MS-013, 0.300" Wide
74VHC4051MTC	MTC16	16-Lead Thin Shrink Small Outline Package (TSSOP), JEDEC MO-153, 4.4mm Wide
74VHC4051N	N16E	16-Lead Plastic Dual-In-Line Package (PDIP), JEDEC MS-001, 0.300" Wide
74VHC4052M	M16A	16-Lead Small Outline Integrated Circuit (SOIC), JEDEC MS-012, 0.150" Narrow
74VHC4052WM	M16B	16-Lead Small Outline Integrated Circuit (SOIC), JEDEC MS-013, 0.300" Wide
74VHC4052MTC	MTC16	16-Lead Thin Shrink Small Outline Package (TSSOP), JEDEC MO-153, 4.4mm Wide
74VHC4053M	M16A	16-Lead Small Outline Integrated Circuit (SOIC), JEDEC MS-012, 0.150" Narrow
74VHC4053WM	M16B	16-Lead Small Outline Integrated Circuit (SOIC), JEDEC MS-013, 0.300" Wide
74VHC4053MTC	MTC16	16-Lead Thin Shrink Small Outline Package (TSSOP), JEDEC MO-153, 4.4mm Wide

Surface mount packages are also available on Tape and Reel. Specify by appending the suffix letter "X" to the ordering number.

Connection Diagrams

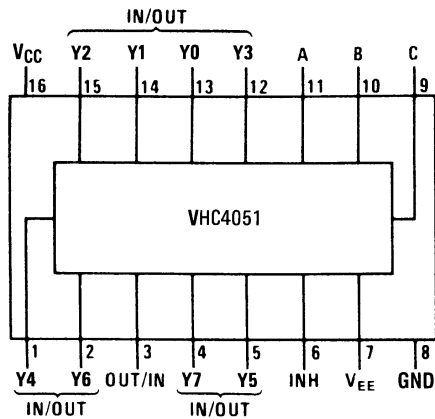

Top View

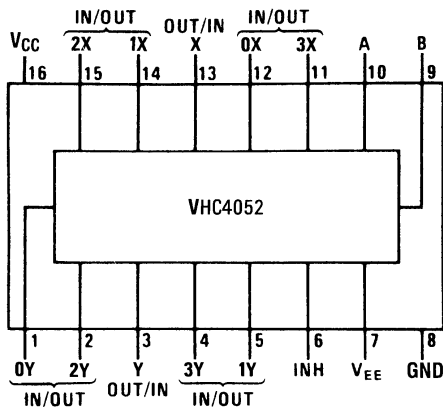

Top View

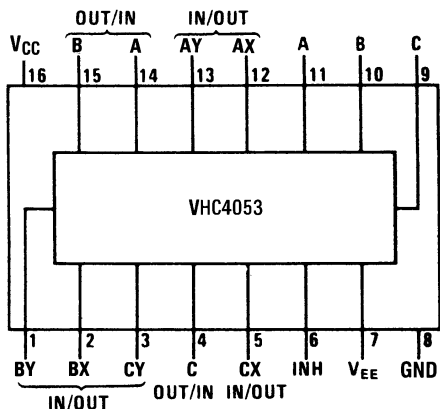

Top View

Truth Tables

74VHC4051

Input				"ON" Channel
INH	C	B	A	
H	X	X	X	None
L	L	L	L	Y0
L	L	L	H	Y1
L	L	H	L	Y2
L	L	H	H	Y3
L	H	L	L	Y4
L	H	L	H	Y5
L	H	H	L	Y6
L	H	H	H	Y7

74VHC4052

Inputs			"ON" Channels	
INH	B	A	X	Y
H	X	X	None	None
L	L	L	0X	0Y
L	L	H	1X	1Y
L	H	L	2X	2Y
L	H	H	3X	3Y

74VHC4053

Input				"ON" Channels		
INH	C	B	A	C	B	A
H	X	X	X	None	None	None
L	L	L	L	CX	BX	AX
L	L	L	H	CX	BX	AY
L	L	H	L	CX	BY	AX
L	L	H	H	CX	BY	AY
L	H	L	L	CY	BX	AX
L	H	L	H	CY	BX	AY
L	H	H	L	CY	BY	AX
L	H	H	H	CY	BY	AY

Logic Diagrams

74VHC4051

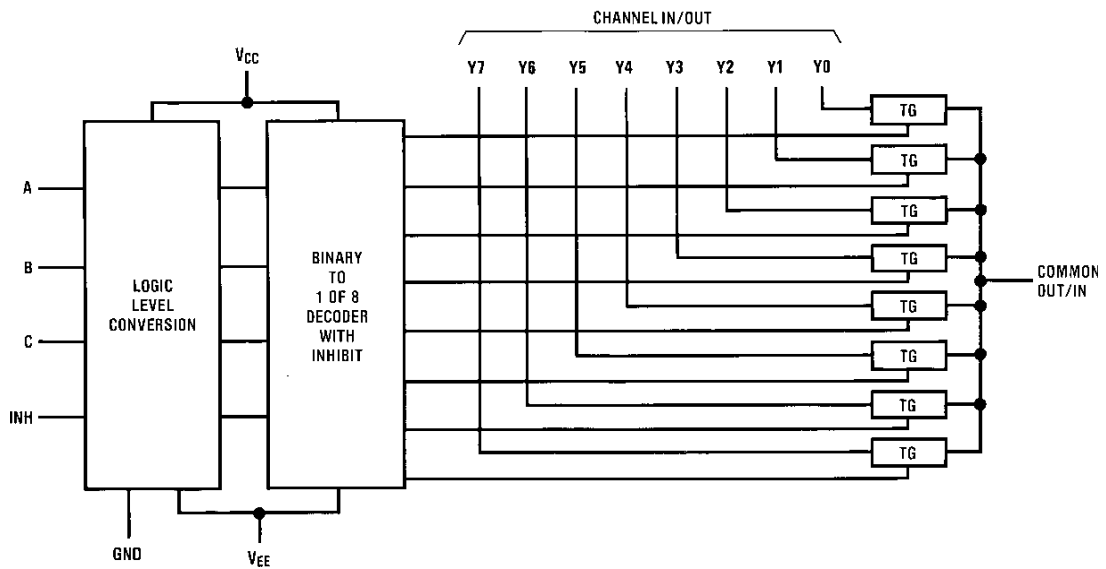

74VHC4052

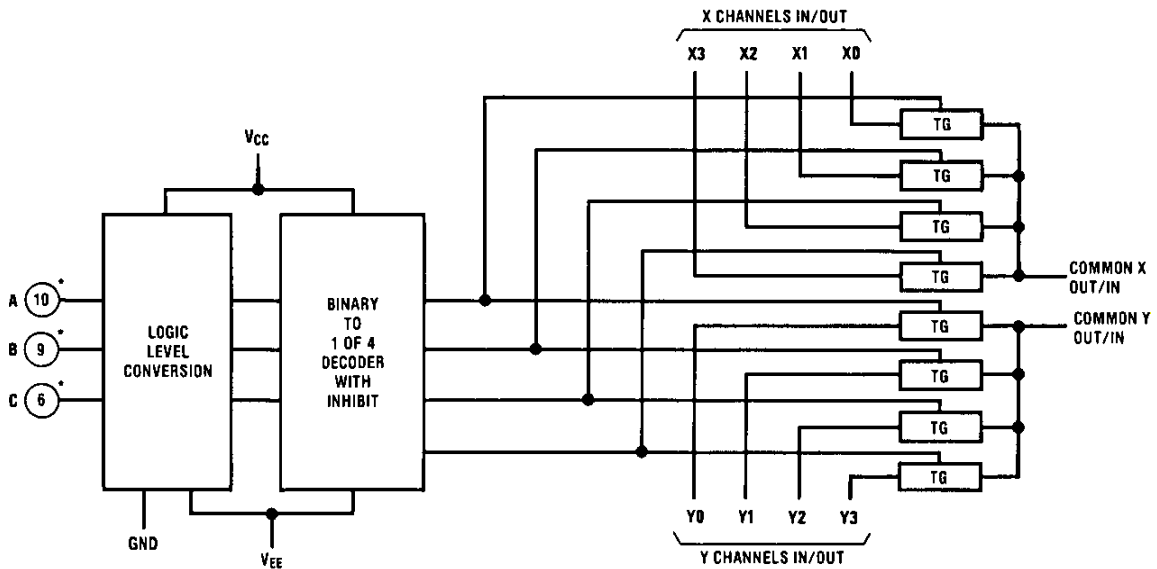

74VHC4051, 8-Channel Analog Multiplexer 74VHC4052, Dual 4-Channel Analog Multiplexer
 74VHC4053, Triple 2-Channel Analog Multiplexer

74VHC4053

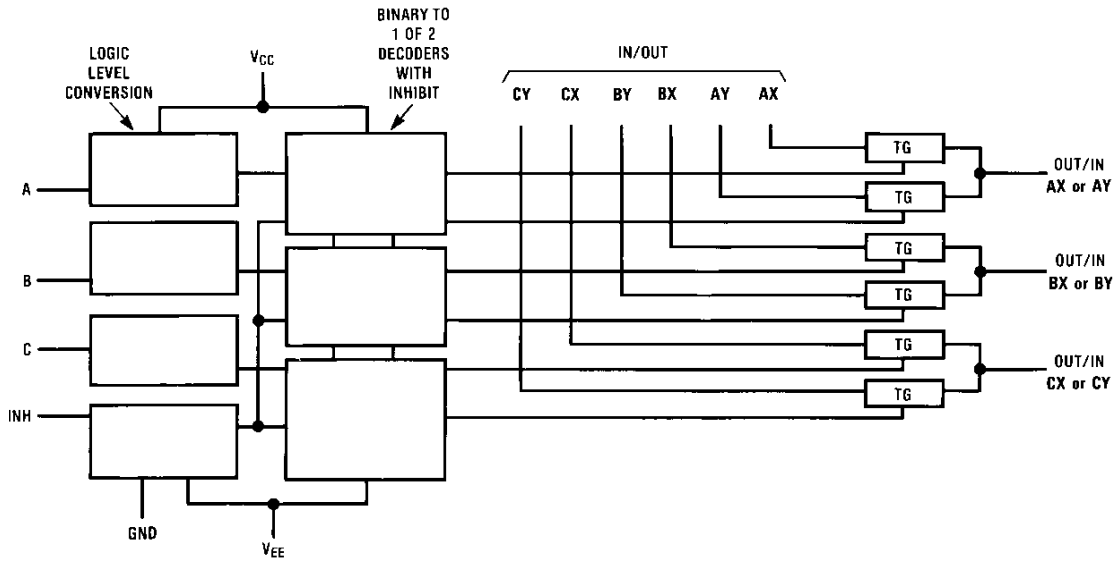

74VHC4051, 8-Channel Analog Multiplexer 74VHC4052, Dual 4-Channel Analog Multiplexer
 74VHC4053, Triple 2-Channel Analog Multiplexer

Absolute Maximum Ratings⁽¹⁾

Stresses exceeding the absolute maximum ratings may damage the device. The device may not function or be operable above the recommended operating conditions and stressing the parts to these levels is not recommended. In addition, extended exposure to stresses above the recommended operating conditions may affect device reliability. The absolute maximum ratings are stress ratings only.

Symbol	Parameter	Rating
V_{CC}	Supply Voltage	-0.5 to +7.5V
V_{EE}	Supply Voltage	+0.5 to -7.5V
V_{IN}	Control Input Voltage	-1.5 to $V_{CC}+1.5V$
V_{IO}	Switch I/O Voltage	$V_{EE}-0.5$ to $V_{CC}+0.5V$
I_{IK}, I_{OK}	Clamp Diode Current	$\pm 20mA$
I_{OUT}	Output Current, per pin	$\pm 25mA$
I_{CC}	V_{CC} or GND Current, per pin	$\pm 50mA$
T_{STG}	Storage Temperature Range	-65°C to +150°C
P_D	Power Dissipation ⁽²⁾	600mW
	S.O. Package only	500mW
T_L	Lead Temperature (Soldering 10 seconds)	260°C

Note:

1. Unless otherwise specified all voltages are referenced to ground.
2. Power Dissipation temperature derating; plastic "N" package: -12mW/°C from 65°C to 85°C.

Recommended Operating Conditions

The Recommended Operating Conditions table defines the conditions for actual device operation. Recommended operating conditions are specified to ensure optimal performance to the datasheet specifications. Fairchild does not recommend exceeding them or designing to absolute maximum ratings.

Symbol	Parameter	Min.	Max.	Units
V_{CC}	Supply Voltage	2	6	V
V_{EE}	Supply Voltage	0	-6	V
V_{IN}, V_{OUT}	DC Input or Output Voltage	0	V_{CC}	V
T_A	Operating Temperature Range	-40	+85	°C
t_r, t_f	Input Rise or Fall Times			
	$V_{CC} = 2.0V$		1000	ns
	$V_{CC} = 4.5V$		500	
	$V_{CC} = 6.0V$		400	

DC Electrical Characteristics⁽³⁾

Symbol	Parameter	Conditions	V _{EE}	V _{CC}	Typ.	T _A = 25°C	T _A = -40 to 85°C	Units	
						Guaranteed Limits			
V _{IH}	Minimum HIGH Level Input Voltage			2.0V		1.5	1.5	V	
				4.5V		3.15	3.15		
				6.0V		4.2	4.2		
V _{IL}	Maximum LOW Level Input Voltage			2.0V		0.5	0.5	V	
				4.5V		1.35	1.35		
				6.0V		1.8	1.8		
R _{ON}	Maximum "ON" Resistance ⁽⁴⁾	V _{INH} = V _{IL} , I _S = 2.0mA, V _{IS} = V _{CC} to V _{EE} (Fig. 1)	GND	4.5V	40	160	200	Ω	
			-4.5V	4.5V	30	120	150		
			-6.0V	6.0V	20	100	125		
		V _{INH} = V _{IL} , I _S = 2.0mA, V _{IS} = V _{CC} or V _{EE} (Fig. 1)	GND	2.0V	100	230	280	Ω	
			GND	4.5V	40	110	140		
			-4.5V	4.5V	20	90	120		
R _{ON}	Maximum "ON" Resistance Matching	V _{INH} = V _{IL} , V _{IS} = V _{CC} to GND	GND	4.5V	10	20	25	Ω	
			-4.5V	4.5V	5	10	15		
			-6.0V	6.0V	5	10	12		
I _N	Maximum Control Input Current	V _{IN} = V _{CC} or GND, V _{CC} = 2 - 6V				±0.05	±0.5	μA	
I _{CC}	Maximum Quiescent Supply Current	V _{IN} = V _{CC} or GND, I _{OUT} = 0μA	GND	6.0V		4	40	μA	
			-6.0V	6.0V		8	80		
I _{IZ}	Maximum Switch "OFF" Leakage Current (Switch Input)	V _{OS} = V _{CC} or V _{EE} , V _{IS} = V _{EE} or V _{CC} , V _{INH} = V _{IH} (Fig. 2)	GND	6.0V		±60	±300	nA	
			-6.0V	6.0V		±100	±500		
I _{IZ}	Maximum Switch "ON" Leakage Current	VHC4051	V _{IS} = V _{CC} to V _{EE} , V _{INH} = V _{IL} (Fig. 3)	GND	6.0V		±0.1	±1.0	μA
				-6.0V	6.0V		±0.2	±2.0	
		VHC4052	V _{IS} = V _{CC} to V _{EE} , V _{INH} = V _{IL} (Fig. 3)	GND	6.0V		±0.050	±0.5	μA
				-6.0V	6.0V		±0.1	±1.0	
		VHC4053	V _{IS} = V _{CC} to V _{EE} , V _{INH} = V _{IL} (Fig. 3)	GND	6.0V		±0.05	±0.5	μA
				-6.0V	6.0V		±0.5	±0.5	
I _{IZ}	Maximum Switch "OFF" Leakage Current (Common Pin)	VHC4051	V _{OS} = V _{CC} or V _{EE} , V _{IS} = V _{EE} or V _{CC} , V _{INH} = V _{IH}	GND	6.0V		±0.1	±1.0	μA
				-6.0V	6.0V		±0.2	±2.0	
		VHC4052	V _{OS} = V _{CC} or V _{EE} , V _{IS} = V _{EE} or V _{CC} , V _{INH} = V _{IH}	GND	6.0V		±0.05	±0.5	μA
				-6.0V	6.0V		±0.1	±1.0	
		VHC4053	V _{OS} = V _{CC} or V _{EE} , V _{IS} = V _{EE} or V _{CC} , V _{INH} = V _{IH}	GND	6.0V		±0.05	±0.5	μA
				-6.0V	6.0V		±0.05	±0.5	

Notes:

- For a power supply of 5V ±10% the worst case on resistances (R_{ON}) occurs for VHC at 4.5V. Thus the 4.5V values should be used when designing with this supply. Worst case V_{IH} and V_{IL} occur at V_{CC} = 5.5V and 4.5V respectively. (The V_{IH} value at 5.5V is 3.85V.) The worst case leakage current occur for CMOS at the higher voltage and so the 5.5V values should be used.
- At supply voltages (V_{CC}-V_{EE}) approaching 2V the analog switch on resistance becomes extremely non-linear. Therefore it is recommended that these devices be used to transmit digital only when using these supply voltages.
- Adjust 0dB for f = 1kHz (Null R1/R_{ON} Attenuation).

AC Electrical Characteristics

$V_{CC} = 2.0V - 6.0V$, $V_{EE} = 0V - 6V$, $C_L = 50pF$ (unless otherwise specified)

Symbol	Parameter	Conditions	V_{EE}	V_{CC}	$T_A = 25^\circ C$		$T_A = -40 \text{ to } 85^\circ C$		Units
					Typ.	Guaranteed Limits			
t_{PHL} , t_{PLH}	Maximum Propagation Delay Switch In to Out		GND	3.3V	25	35	40	ns	
			GND	4.5V	5	12	15		
			-4.5V	4.5V	4	8	12		
			-6.0V	6.0V	3	7	11		
t_{PZL} , t_{PZH}	Maximum Switch Turn "ON" Delay	$R_L = 1k\Omega$	GND	3.3V	92	200	250	ns	
			GND	4.5V		69	87		
			-4.5V	4.5V	16	46	58		
			-6.0V	6.0V	15	41	51		
t_{PHZ} , t_{PLZ}	Maximum Switch Turn "OFF" Delay		GND	3.3V	65	170	210	ns	
			GND	4.5V	28	58	73		
			-4.5V	4.5V	18	37	46		
			-6.0V	6.0V	16	32	41		
f_{MAX}	Minimum Switch Frequency Response $20 \log (V_I/V_O) = 3dB$		GND	4.5V	30			MHz	
			-4.5V	4.5V	35				
	Control to Switch Feedthrough Noise	$R_L = 600\Omega$, $f = 1MHz$, $C_L = 50pF$	$V_{IS} = 4 V_{PP}$	0V	4.5V	1080		mV	
			$V_{IS} = 8 V_{PP}$	-4.5V	4.5V	250			
	Crosstalk Between any Two Switches	$R_L = 600\Omega$, $f = 1 MHz$	$V_{IS} = 4 V_{PP}$	0V	4.5	-52		dB	
			$V_{IS} = 8 V_{PP}$	-4.5V	4.5V	-50			
	Switch OFF Signal Feedthrough Isolation	$R_L = 600\Omega$, $f = 1 MHz$, $V_{CTL} = V_{IL}$	$V_{IS} = 4 V_{PP}$	0V	4.5V	-42		dB	
			$V_{IS} = 8 V_{PP}$	-4.5V	4.5V	-44			
THD	Sinewave Harmonic Distortion	$R_L = 10k\Omega$, $C_L = 50pF$, $f = 1kHz$	$V_{IS} = 4 V_{PP}$	0V	4.5V	0.013		%	
			$V_{IS} = 8 V_{PP}$	-4.5V	4.5V	0.008			
C_{IN}	Maximum Control Input Capacitance				5	10	10	pF	
C_{IN}	Maximum Switch Input Capacitance	Input			15			pF	
		4051 Common			90				
		4052 Common			45				
		4053 Common			30				
C_{IN}	Maximum Feedthrough Capacitance				5			pF	

AC Test Circuits and Switching Time Waveforms

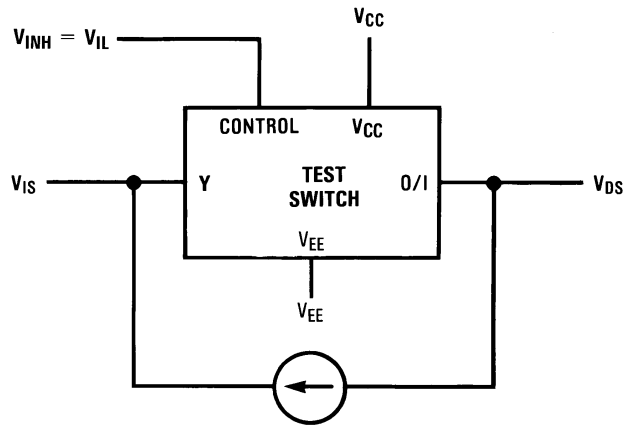

Figure 1. "ON" Resistance

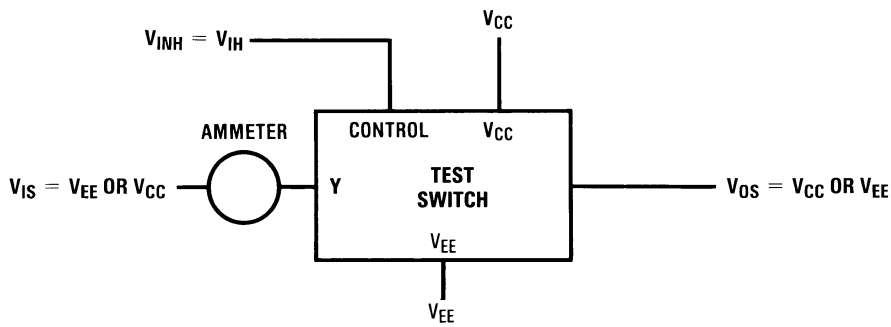

Figure 2. "OFF" Channel Leakage Current

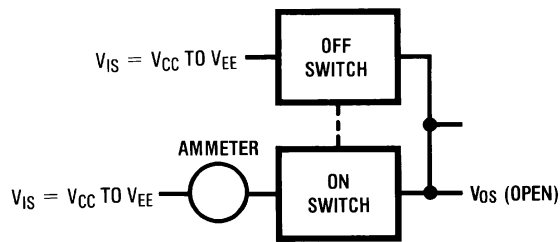

Figure 3. "ON" Channel Leakage Current

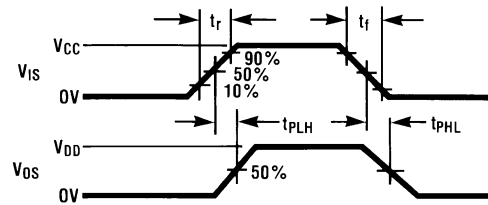
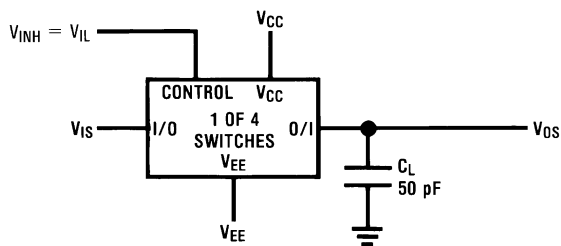

Figure 4. t_{PLH} , t_{PLL} Propagation Delay Time Signal Input to Signal Output

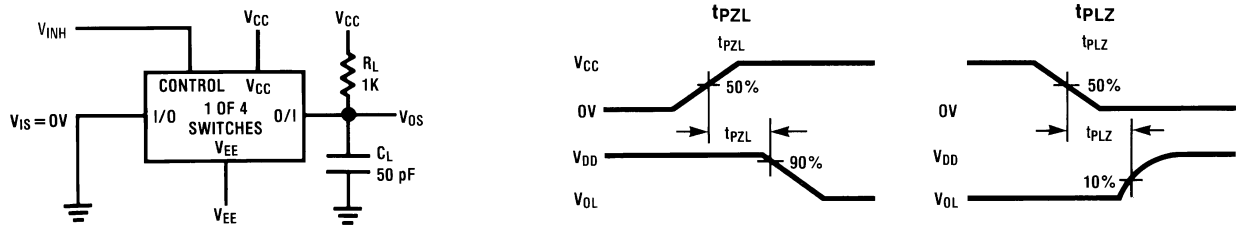

Figure 5. t_{PZL} , t_{PLZ} Propagation Delay Time Control to Signal Output

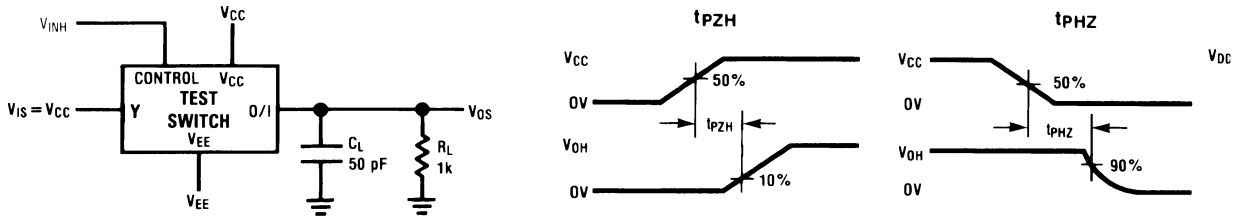

Figure 6. t_{PZH} , t_{PHZ} Propagation Delay Time Control to Signal Output

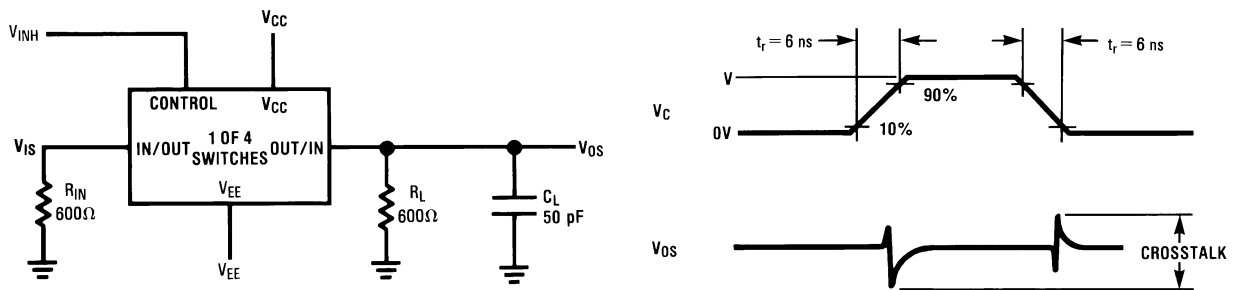

Figure 7. Crosstalk: Control Input to Signal Output

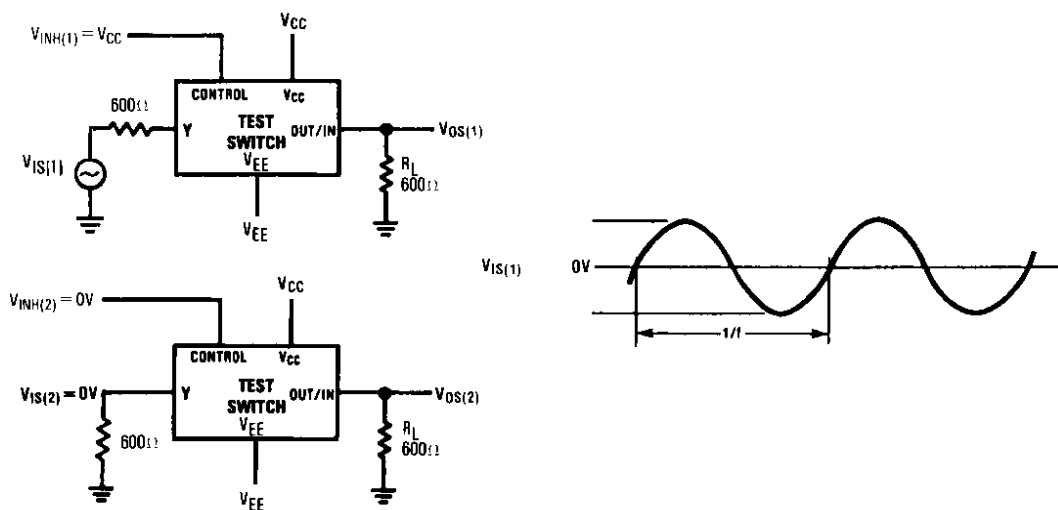
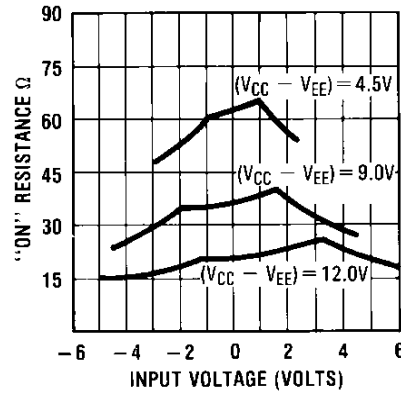

Figure 8. Crosstalk Between Any Two Switches

Typical Performance Characteristics

Typical "On" Resistance vs Input Voltage



$$V_{CC} = -V_{EE}$$

Special Considerations

In certain applications the external load-resistor current may include both V_{CC} and signal line components. To avoid drawing V_{CC} current when switch current flows into the analog switch pins, the voltage drop across the switch must not exceed 1.2V (calculated from the ON resistance).

Physical Dimensions

Dimensions are in millimeters unless otherwise noted.

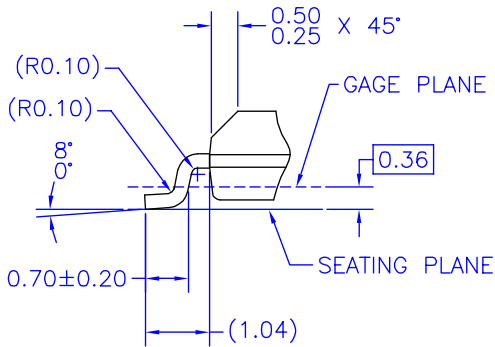
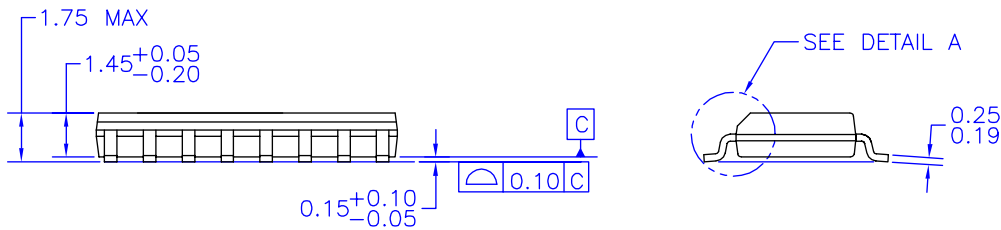
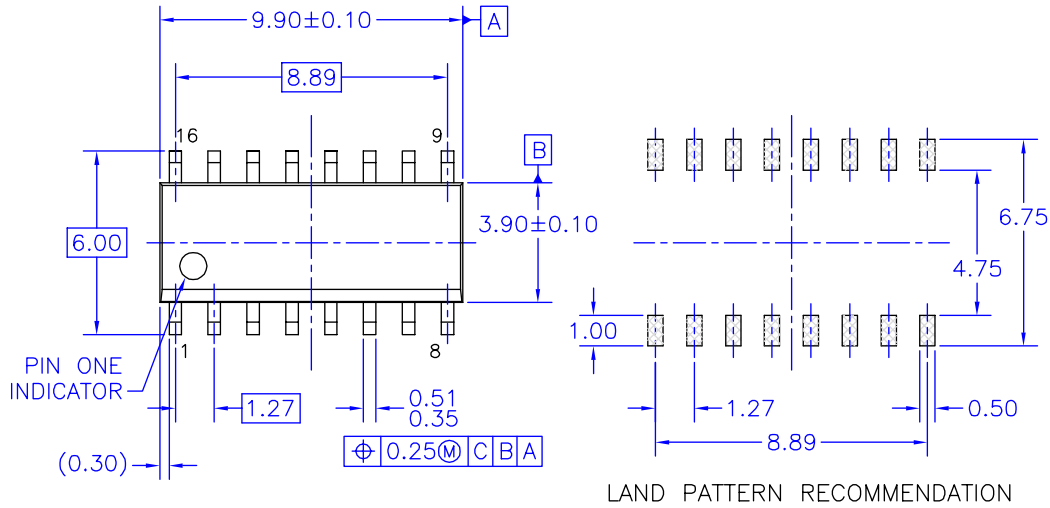

DETAIL A
 SCALE: 2:1

NOTES: UNLESS OTHERWISE SPECIFIED

- A) THIS PACKAGE CONFORMS TO JEDEC MS-012, VARIATION AC, ISSUE C, DATED MAY 1990.
- B) ALL DIMENSIONS ARE IN MILLIMETERS.
- C) DIMENSIONS DO NOT INCLUDE MOLD FLASH OR BURRS.
- D) STANDARD LEAD FINISH:
 200 MICRONS / 5.08 MICRONS MIN.
 LEAD/TIN (SOLDER) ON COPPER.

M16AREVK

Figure 9. 16-Lead Small Outline Integrated Circuit (SOIC), JEDEC MS-012, 0.150" Narrow Package Number M16A

Physical Dimensions (Continued)

Dimensions are in inches (millimeters) unless otherwise noted.

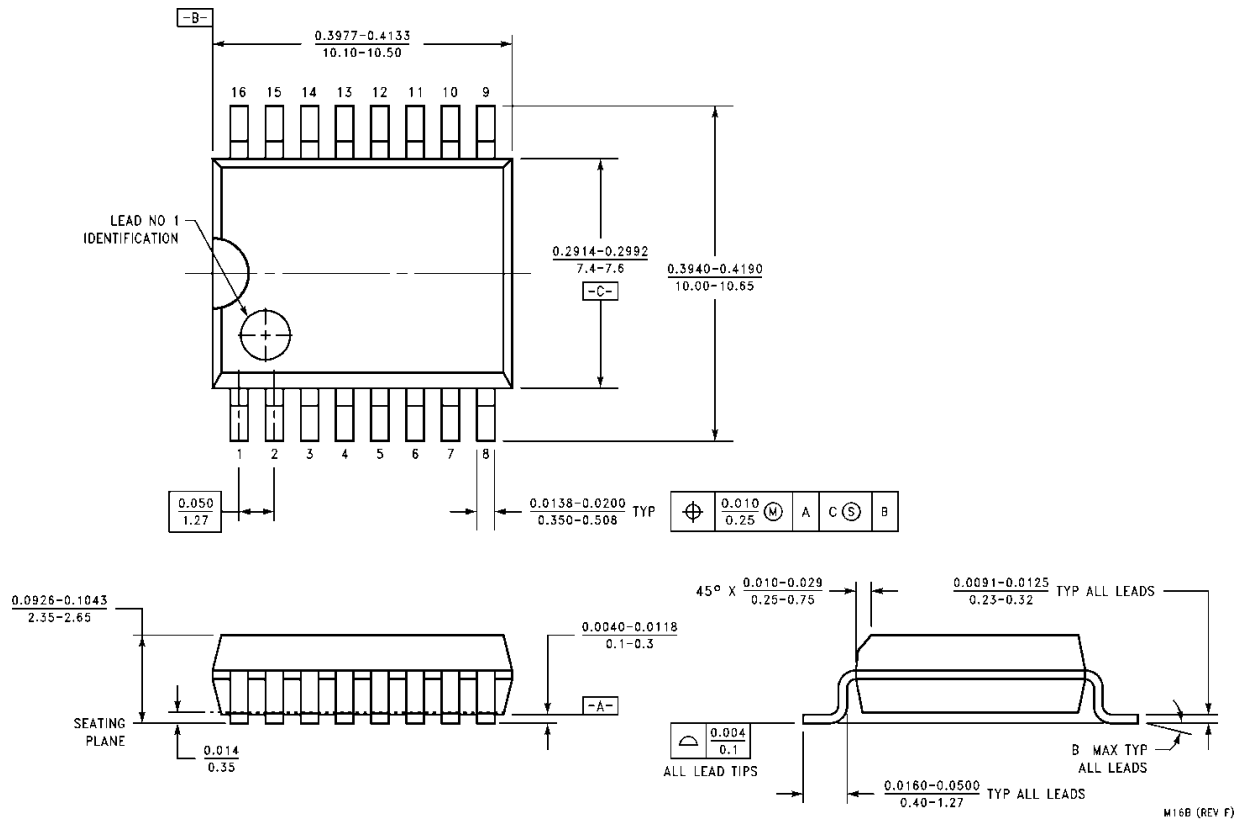
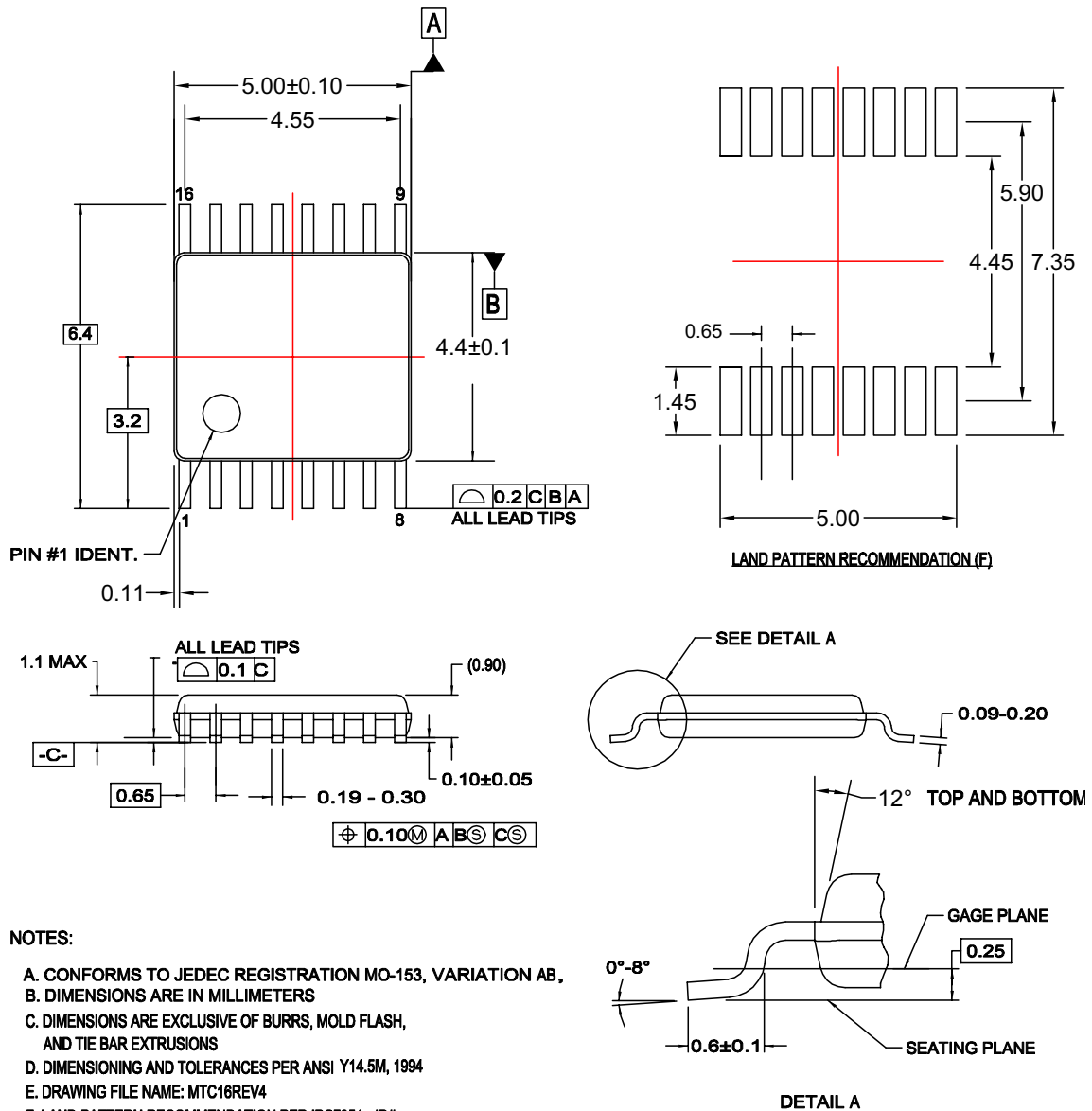

Figure 10. 16-Lead Small Outline Intergrated Circuit (SOIC), JEDEC MS-013, 0.300" Wide
 Package Number M16B

Physical Dimensions (Continued)

Dimensions are in millimeters unless otherwise noted.



MTC16rev4

Figure 11. 16-Lead Thin Shrink Small Outline Package (TSSOP), JEDEC MO-153, 4.4mm Wide Package Number MTC16

Physical Dimensions (Continued)

Dimensions are in inches (millimeters) unless otherwise noted.

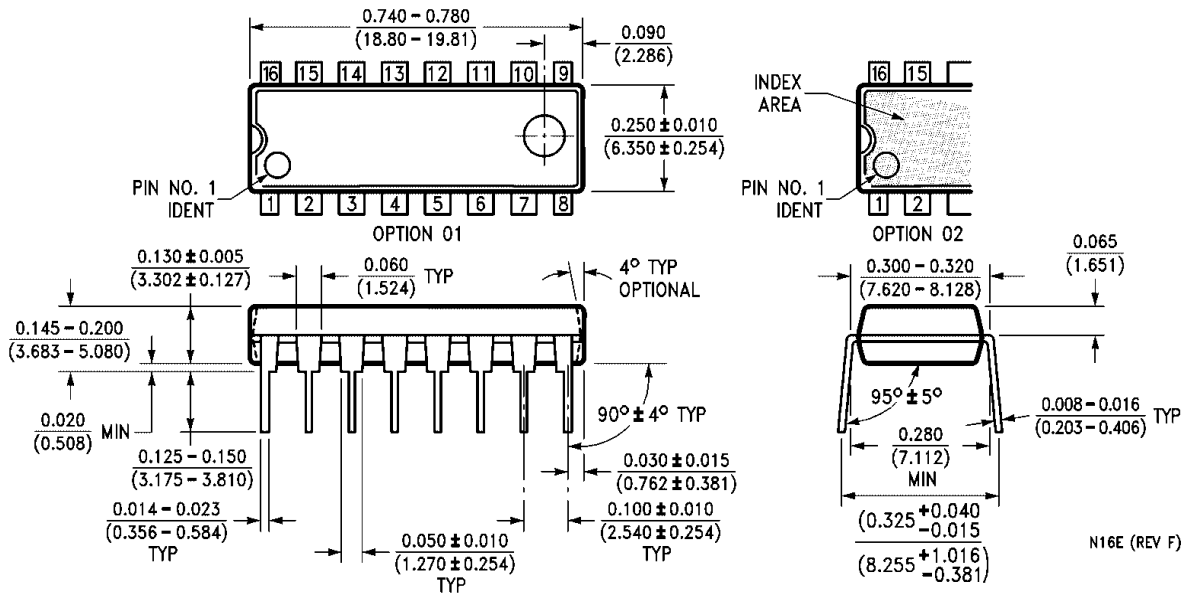



Figure 12. 16-Lead Plastic Dual-In-Line Package (PDIP), JEDEC MS-001, 0.300" Wide Package Number N16E



TRADEMARKS

The following are registered and unregistered trademarks Fairchild Semiconductor owns or is authorized to use and is not intended to be an exhaustive list of all such trademarks.

ACE ^x	HiSeC TM	Power-SPM TM	TinyBuck TM
Across the board. Around the world. TM	<i>i-Lo</i> TM	PowerTrench [®]	TinyLogic [®]
ActiveArray TM	ImpliedDisconnect TM	Programmable Active Droop TM	TINYOPTO TM
Bottomless TM	IntelliMAX TM	QFET [®]	TinyPower TM
Build it Now TM	ISOPLANAR TM	QS TM	TinyWire TM
CoolFET TM	MICROCOUPLER TM	QT Optoelectronics TM	TruTranslation TM
CorePLUS TM	MicroPak TM	Quiet Series TM	μSerDes TM
CROSSVOLT TM	MICROWIRE TM	RapidConfigure TM	UHC [®]
CTL TM	Motion-SPM TM	RapidConnect TM	UniFET TM
Current Transfer Logic TM	MSX TM	ScalarPump TM	VCX TM
DOME TM	MSXPro TM	SMART START TM	Wire TM
E ² C MOS TM	OCX TM	SPM [®]	
EcoSPARK [®]	OCXPro TM	STEALTH TM	
EnSigna TM	OPTOLOGIC [®]	SuperFET TM	
FACT Quiet Series TM	OPTOPLANAR [®]	SuperSOT TM -3	
FACT [®]	PACMAN TM	SuperSOT TM -6	
FAST [®]	PDP-SPM TM	SuperSOT TM -8	
FASTr TM	POP TM	SyncFET TM	
FPS TM	Power220 [®]	TCM TM	
FRFET [®]	Power247 [®]	The Power Franchise [®]	
GlobalOptoisolator TM	PowerEdge TM	 TM	
GTO TM	PowerSaver TM	TinyBoost TM	

DISCLAIMER

FAIRCHILD SEMICONDUCTOR RESERVES THE RIGHT TO MAKE CHANGES WITHOUT FURTHER NOTICE TO ANY PRODUCTS HEREIN TO IMPROVE RELIABILITY, FUNCTION, OR DESIGN. FAIRCHILD DOES NOT ASSUME ANY LIABILITY ARISING OUT OF THE APPLICATION OR USE OF ANY PRODUCT OR CIRCUIT DESCRIBED HEREIN; NEITHER DOES IT CONVEY ANY LICENSE UNDER ITS PATENT RIGHTS, NOR THE RIGHTS OF OTHERS. THESE SPECIFICATIONS DO NOT EXPAND THE TERMS OF FAIRCHILD'S WORLDWIDE TERMS AND CONDITIONS, SPECIFICALLY THE WARRANTY THEREIN, WHICH COVERS THESE PRODUCTS.

LIFE SUPPORT POLICY

FAIRCHILD'S PRODUCTS ARE NOT AUTHORIZED FOR USE AS CRITICAL COMPONENTS IN LIFE SUPPORT DEVICES OR SYSTEMS WITHOUT THE EXPRESS WRITTEN APPROVAL OF FAIRCHILD SEMICONDUCTOR CORPORATION.

As used herein:

- Life support devices or systems are devices or systems which, (a) are intended for surgical implant into the body or (b) support or sustain life, and (c) whose failure to perform when properly used in accordance with instructions for use provided in the labeling, can be reasonably expected to result in a significant injury of the user.
- A critical component in any component of a life support device, or system whose failure to perform can be reasonably expected to cause the failure of the life support device or system, or to affect its safety or effectiveness.

PRODUCT STATUS DEFINITIONS

Definition of Terms

Datasheet Identification	Product Status	Definition
Advance Information	Formative or In Design	This datasheet contains the design specifications for product development. Specifications may change in any manner without notice.
Preliminary	First Production	This datasheet contains preliminary data; supplementary data will be published at a later date. Fairchild Semiconductor reserves the right to make changes at any time without notice to improve design.
No Identification Needed	Full Production	This datasheet contains final specifications. Fairchild Semiconductor reserves the right to make changes at any time without notice to improve design.
Obsolete	Not In Production	This datasheet contains specifications on a product that has been discontinued by Fairchild Semiconductor. The datasheet is printed for reference information only.

Rev. I27

Looking for pricing, stock, or lifecycle information?

Click below to explore more details on WIN SOURCE:

 [View 74VHC4051MX](#) on WIN SOURCE

 [Fairchild/ON Semiconductor](#) Information

Optimize Your Supply Chain with WIN SOURCE Solutions

-  Global Sourcing Solution
-  Obsolete Management
-  Cost Control Management
-  Shortage Management
-  Alternative Solution
-  Excess Inventory Management