



THE DATASHEET OF STP34NM60N



N-channel 600 V, 0.092 Ω , 31.5 A MDmesh™ II Power MOSFETs
in D²PAK and TO-220 packages

Datasheet - production data

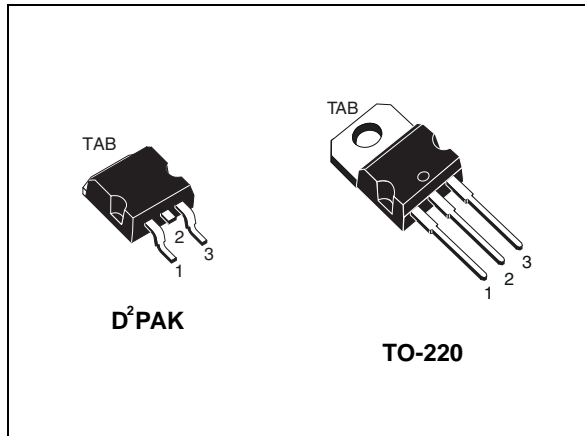
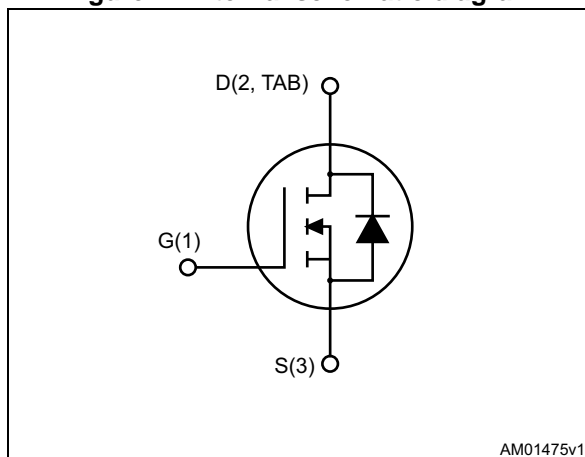

Figure 1. Internal schematic diagram



Features

Order codes	V _{DSS}	R _{DS(on)}	I _D	P _{TOT}
STB34NM60N	600 V	0.105 Ω	31.5 A	250 W
STP34NM60N				

- 100% avalanche tested
- Low input capacitance and gate charge
- Low gate input resistance

Applications

- Switching applications

Description

These devices are N-channel Power MOSFETs developed using the second generation of MDmesh™ technology. This revolutionary Power MOSFET associates a vertical structure to the company's strip layout to yield one of the world's lowest on-resistance and gate charge. It is therefore suitable for the most demanding high efficiency converters.

Table 1. Device summary

Order codes	Marking	Packages	Packaging
STB34NM60N	34NM60N	D ² PAK	Tape and reel
STP34NM60N		TO-220	Tube

Contents

- 1 Electrical ratings 3**
- 2 Electrical characteristics 4**
 - 2.1 Electrical characteristics (curves) 6
- 3 Test circuits 8**
- 4 Package information 9**
 - 4.1 D²PAK package information 9
 - 4.2 TO-220 package information 12
- 5 Packing information 14**
- 6 Revision history 16**

1 Electrical ratings

Table 2. Absolute maximum ratings

Symbol	Parameter	Value	Unit
V_{DS}	Drain-source voltage	600	V
V_{GS}	Gate-source voltage	± 25	V
I_D	Drain current (continuous) at $T_C = 25\text{ }^\circ\text{C}$	31.5	A
I_D	Drain current (continuous) at $T_C = 100\text{ }^\circ\text{C}$	20	A
$I_{DM}^{(1)}$	Drain current (pulsed)	126	A
P_{TOT}	Total dissipation at $T_C = 25\text{ }^\circ\text{C}$	250	W
I_{AR}	Max current during repetitive or single pulse avalanche (pulse width limited by T_{jmax})	7	A
E_{AS}	Single pulse avalanche energy (starting $T_J = 25\text{ }^\circ\text{C}$, $I_D = I_{AS}$, $V_{DD} = 50\text{ V}$)	345	mJ
$dv/dt^{(2)}$	Peak diode recovery voltage slope	15	V/ns
$dv/dt^{(3)}$	MOSFET dv/dt ruggedness	50	V/ns
T_{stg}	Storage temperature	-55 to 150	$^\circ\text{C}$
T_j	Max. operating junction temperature	150	$^\circ\text{C}$

1. Pulse width limited by safe operating area.
2. $I_{SD} \leq 31.5\text{ A}$, $di/dt \leq 400\text{ A}/\mu\text{s}$, $V_{DS\text{ peak}} \leq V_{(BR)DSS}$, $V_{DD} = 80\% V_{(BR)DSS}$
3. $V_{DS} \leq 480\text{ V}$

Table 3. Thermal data

Symbol	Parameter	Value		Unit
		D ² PAK	TO-220	
$R_{thj-case}$	Thermal resistance junction-case max	0.5		$^\circ\text{C}/\text{W}$
$R_{thj-amb}$	Thermal resistance junction-amb max		62.5	
$R_{thj-pcb}^{(1)}$	Thermal resistance junction-pcb max	30		

1. When mounted on 1 inch² FR-4, 2 Oz copper board.

2 Electrical characteristics

($T_{CASE} = 25\text{ °C}$ unless otherwise specified).

Table 4. On/off states

Symbol	Parameter	Test conditions	Min.	Typ.	Max.	Unit
$V_{(BR)DSS}$	Drain-source breakdown voltage ($V_{GS} = 0$)	$I_D = 1\text{ mA}$	600			V
I_{DSS}	Zero gate voltage drain current ($V_{GS} = 0$)	$V_{DS} = 600\text{ V}$ $V_{DS} = 600\text{ V}, T_c = 125\text{ °C}$			1 100	μA μA
I_{GSS}	Gate body leakage current ($V_{DS} = 0$)	$V_{GS} = \pm 25\text{ V}$			± 100	nA
$V_{GS(th)}$	Gate threshold voltage	$V_{DS} = V_{GS}, I_D = 250\text{ }\mu\text{A}$	2	3	4	V
$R_{DS(on)}$	Static drain-source on-resistance	$V_{GS} = 10\text{ V}, I_D = 14.5\text{ A}$		0.092	0.105	Ω

Table 5. Dynamic

Symbol	Parameter	Test conditions	Min.	Typ.	Max.	Unit
C_{iss}	Input capacitance	$V_{DS} = 100\text{ V}, f = 1\text{ MHz}, V_{GS} = 0$	-	2722	-	pF
C_{oss}	Output capacitance		-	173	-	pF
C_{rss}	Reverse transfer capacitance		-	1.75	-	pF
$C_{oss\text{ eq.}}^{(1)}$	Equivalent capacitance time related	$V_{GS} = 0, V_{DS} = 0\text{ to }480\text{ V}$	-	458	-	pF
$t_{d(on)}$	Turn-on delay time	$V_{DD} = 300\text{ V}, I_D = 15.75\text{ A},$ $R_G = 4.7\text{ }\Omega, V_{GS} = 10\text{ V}$ (see Figure 19 and 14)	-	18	-	ns
t_r	Rise time		-	36	-	ns
$t_{d(off)}$	Turn-off delay time		-	104	-	ns
t_f	Fall time		-	73	-	ns
Q_g	Total gate charge	$V_{DD} = 480\text{ V}, I_D = 31.5\text{ A}$ $V_{GS} = 10\text{ V}$ (see Figure 15)	-	84	-	nC
Q_{gs}	Gate-source charge		-	14	-	nC
Q_{gd}	Gate-drain charge		-	45	-	nC
R_G	Intrinsic gate resistance	$f = 1\text{ MHz},$ gate DC Bias=0 test signal level=20 mV open drain	-	2.9	-	Ω

1. $C_{oss\text{ eq.}}$ is defined as a constant equivalent capacitance giving the same charging time as C_{oss} when V_{DS} increases from 0 to 80% V_{DSS}

Table 6. Source drain diode

Symbol	Parameter	Test conditions	Min.	Typ.	Max.	Unit
I_{SD}	Source-drain current		-		31.5	A
$I_{SDM}^{(1)}$	Source-drain current (pulsed)		-		126	A
$V_{SD}^{(2)}$	Forward on voltage	$I_{SD}= 31.5 \text{ A}, V_{GS}=0$	-		1.6	V
t_{rr}	Reverse recovery time	$I_{SD}= 31.5 \text{ A}, V_{DD}= 60 \text{ V}$ $di/dt = 100 \text{ A}/\mu\text{s}$, (see Figure 16)	-	412		ns
Q_{rr}	Reverse recovery charge		-	8		μC
I_{RRM}	Reverse recovery current		-	39		A
t_{rr}	Reverse recovery time	$I_{SD}= 31.5 \text{ A}, V_{DD}= 60 \text{ V}$ $di/dt=100 \text{ A}/\mu\text{s}$, $T_j=150 \text{ }^\circ\text{C}$ (see Figure 16)	-	490		ns
Q_{rr}	Reverse recovery charge		-	10		μC
I_{RRM}	Reverse recovery current		-	43		A

1. Pulse width limited by safe operating area
2. Pulsed: Pulse duration = 300 μs , duty cycle 1.5%.

2.1 Electrical characteristics (curves)

Figure 2. Safe operating area

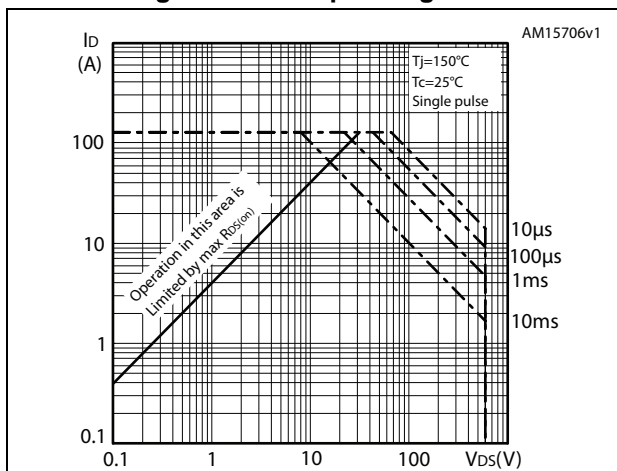

Figure 3. Thermal impedance

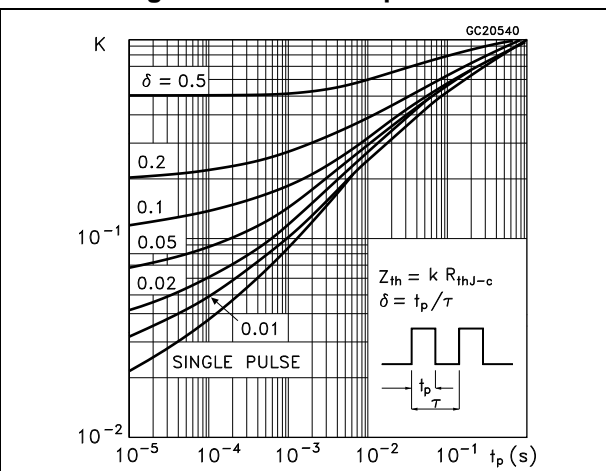

Figure 4. Output characteristics

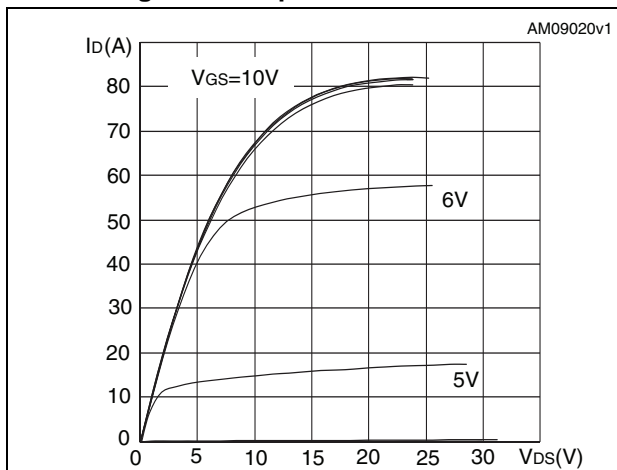

Figure 5. Transfer characteristics

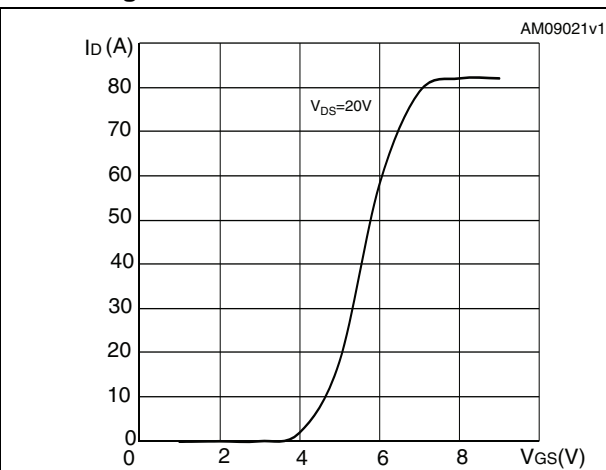

Figure 6. Gate charge vs gate-source voltage

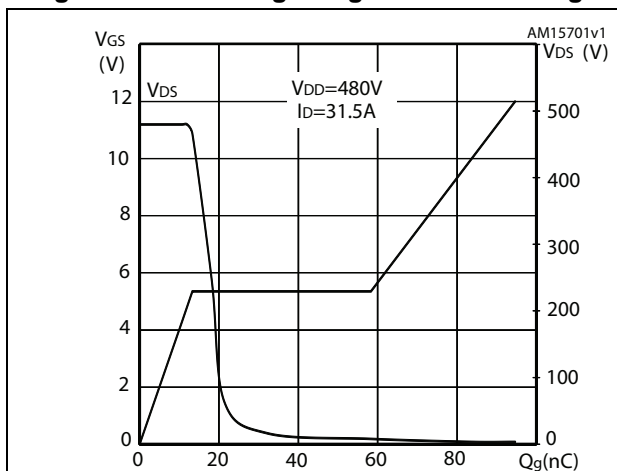

Figure 7. Static drain-source on-resistance

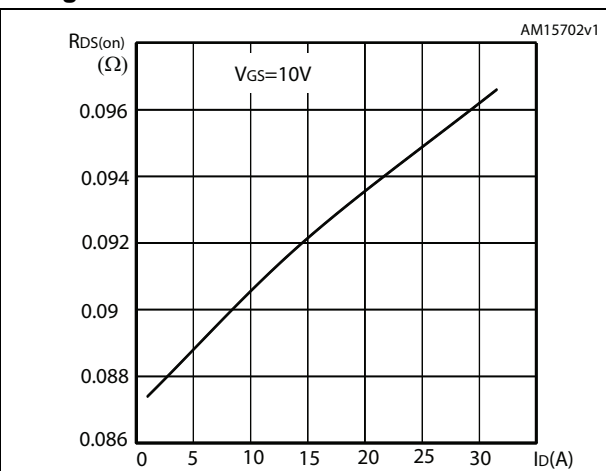

Figure 8. Capacitance variations

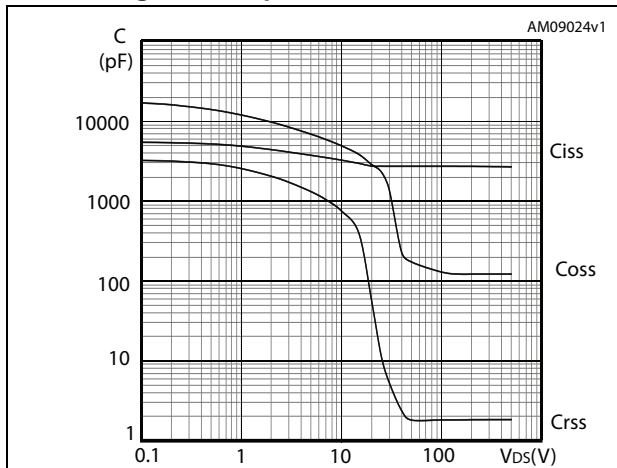

Figure 9. Output capacitance stored energy

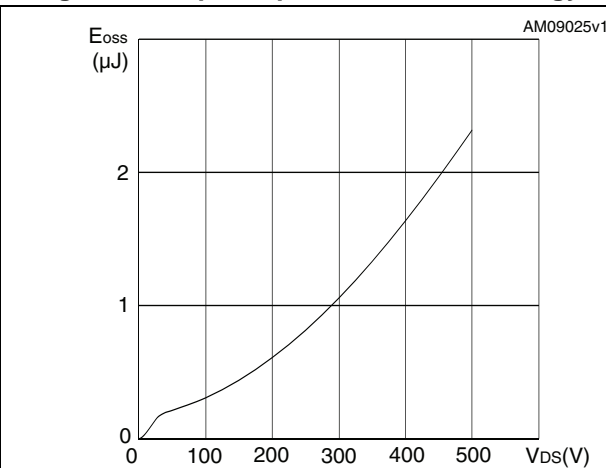

Figure 10. Normalized gate threshold voltage vs temperature

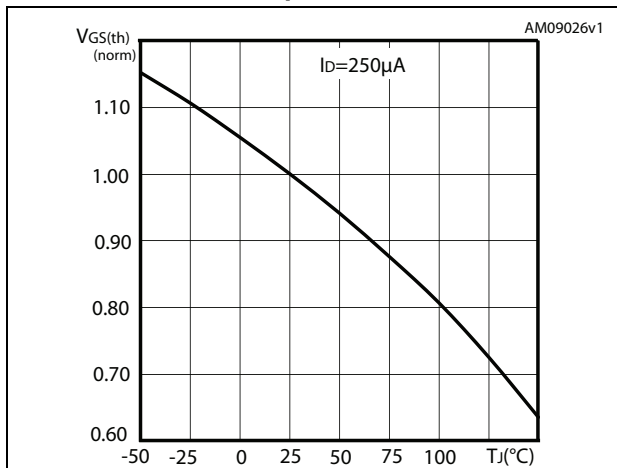

Figure 11. Normalized on-resistance vs temperature

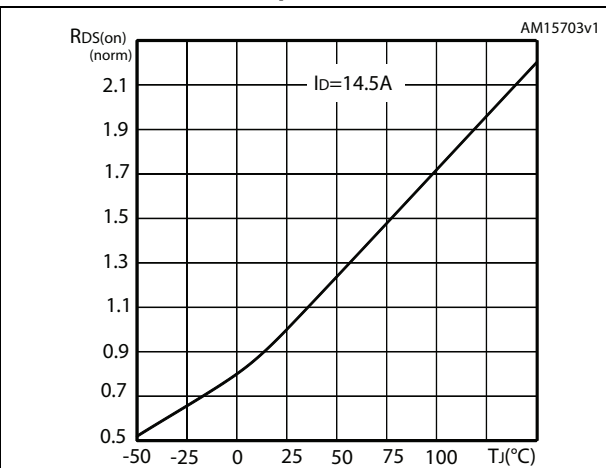

Figure 12. Normalized B_{VDS} vs temperature

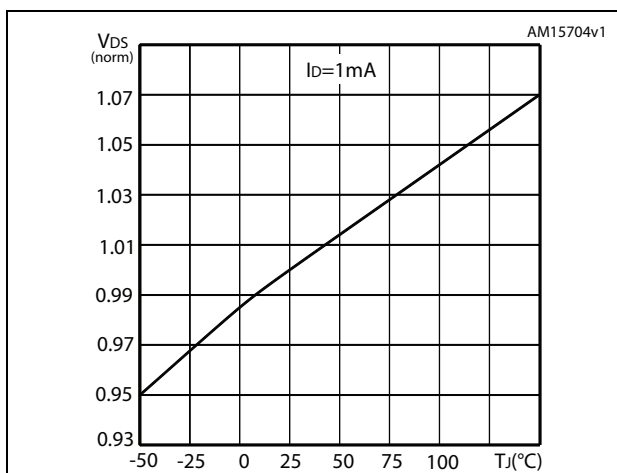
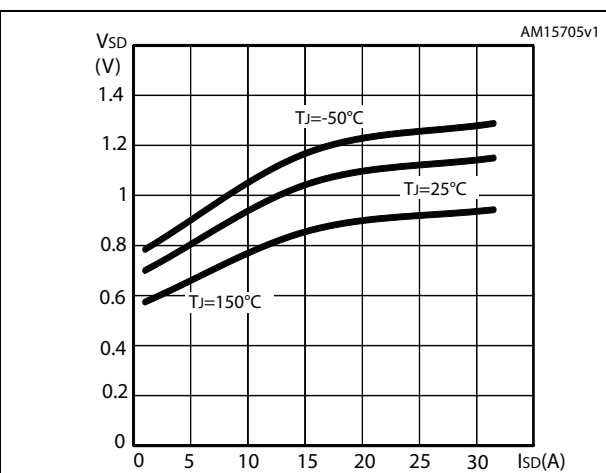
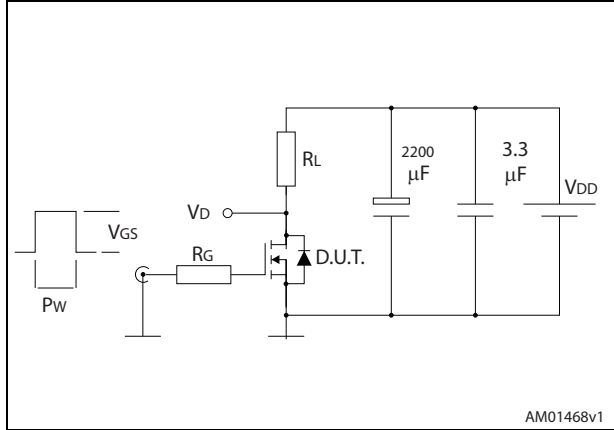

Figure 13. Source-drain diode forward characteristics



3 Test circuits

Figure 14. Switching times test circuit for resistive load



AM01468v1

Figure 15. Gate charge test circuit

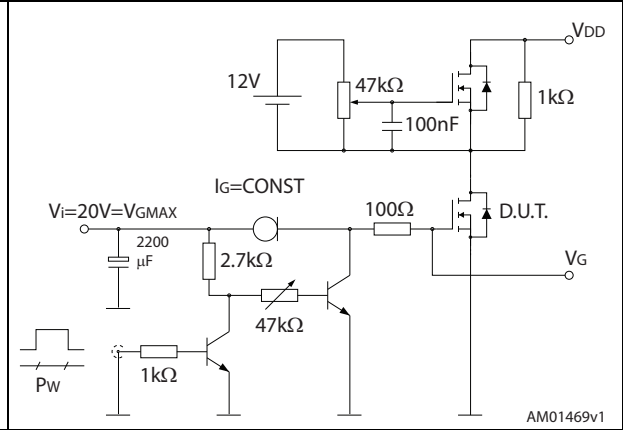

AM01469v1

Figure 16. Test circuit for inductive load switching and diode recovery times

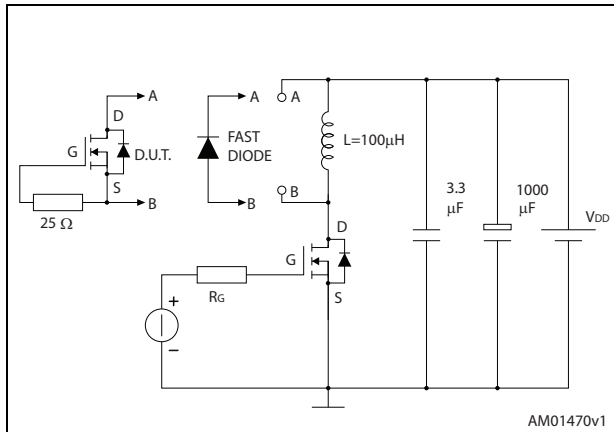

AM01470v1

Figure 17. Unclamped inductive load test circuit

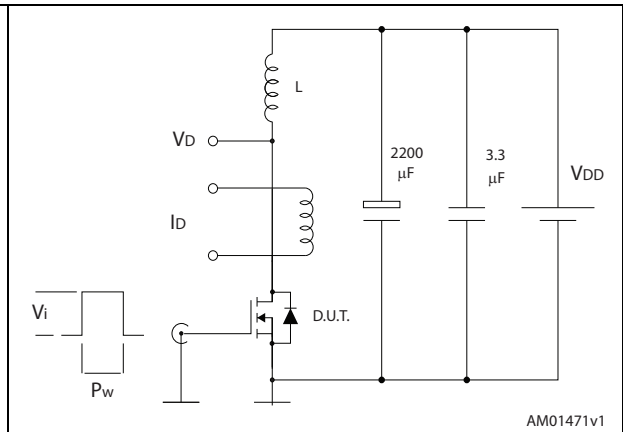

AM01471v1

Figure 18. Unclamped inductive waveform

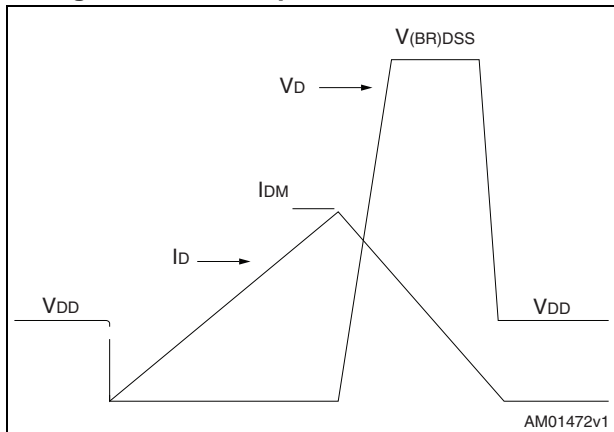

AM01472v1

Figure 19. Switching time waveform

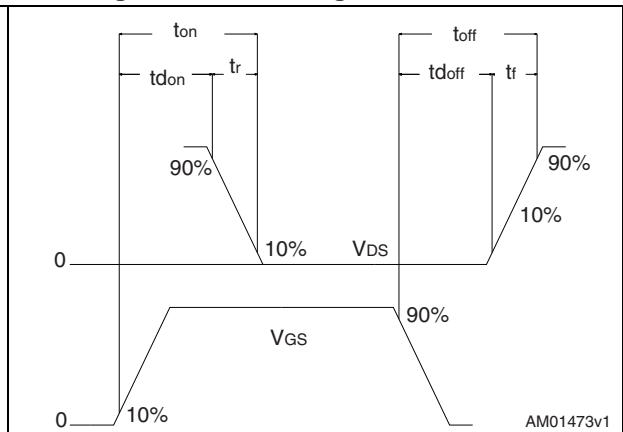

AM01473v1

4 Package information

In order to meet environmental requirements, ST offers these devices in different grades of ECOPACK® packages, depending on their level of environmental compliance. ECOPACK® specifications, grade definitions and product status are available at: www.st.com. ECOPACK® is an ST trademark.

4.1 D²PAK package information

Figure 20. D²PAK (TO-263) outline

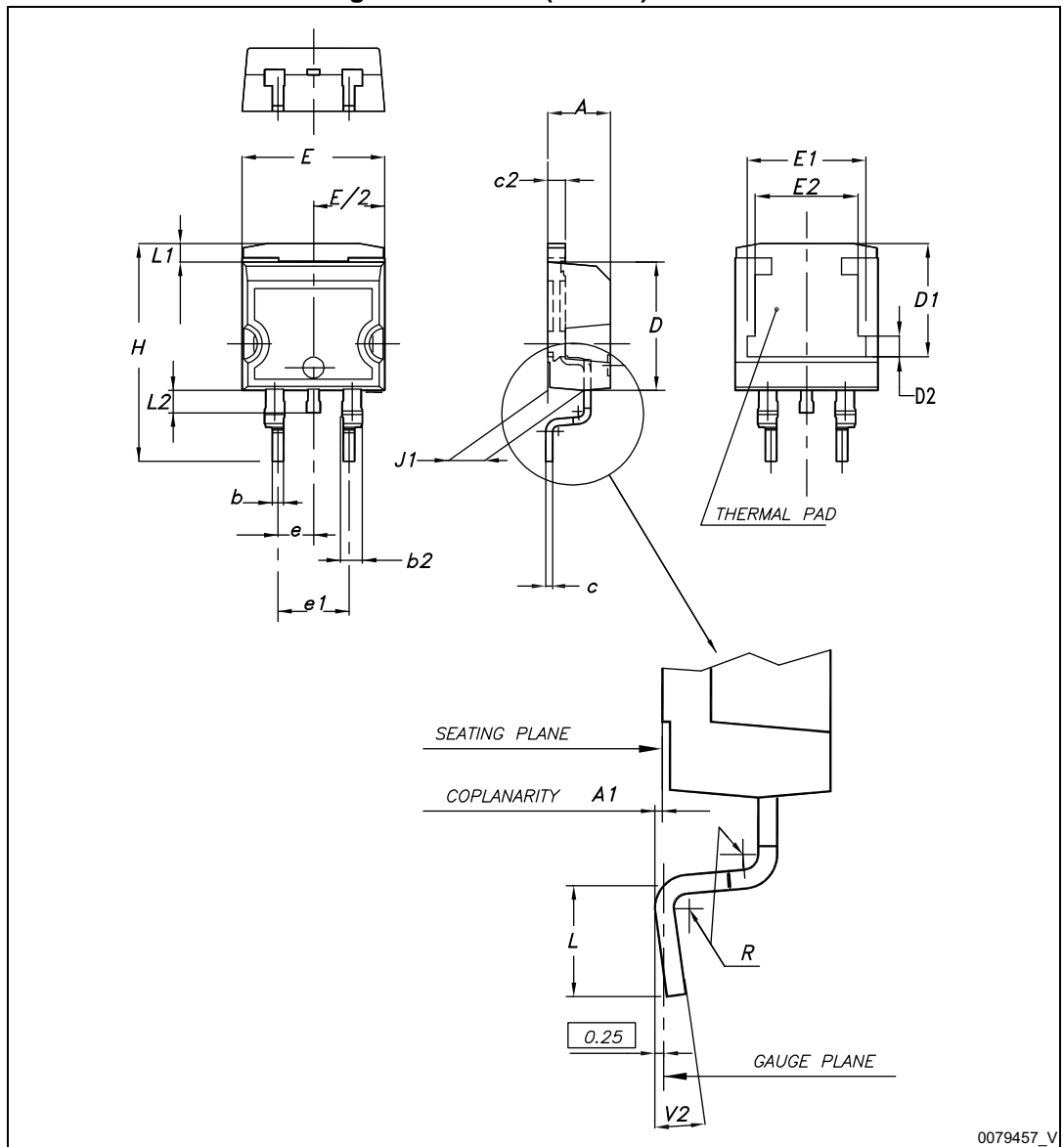
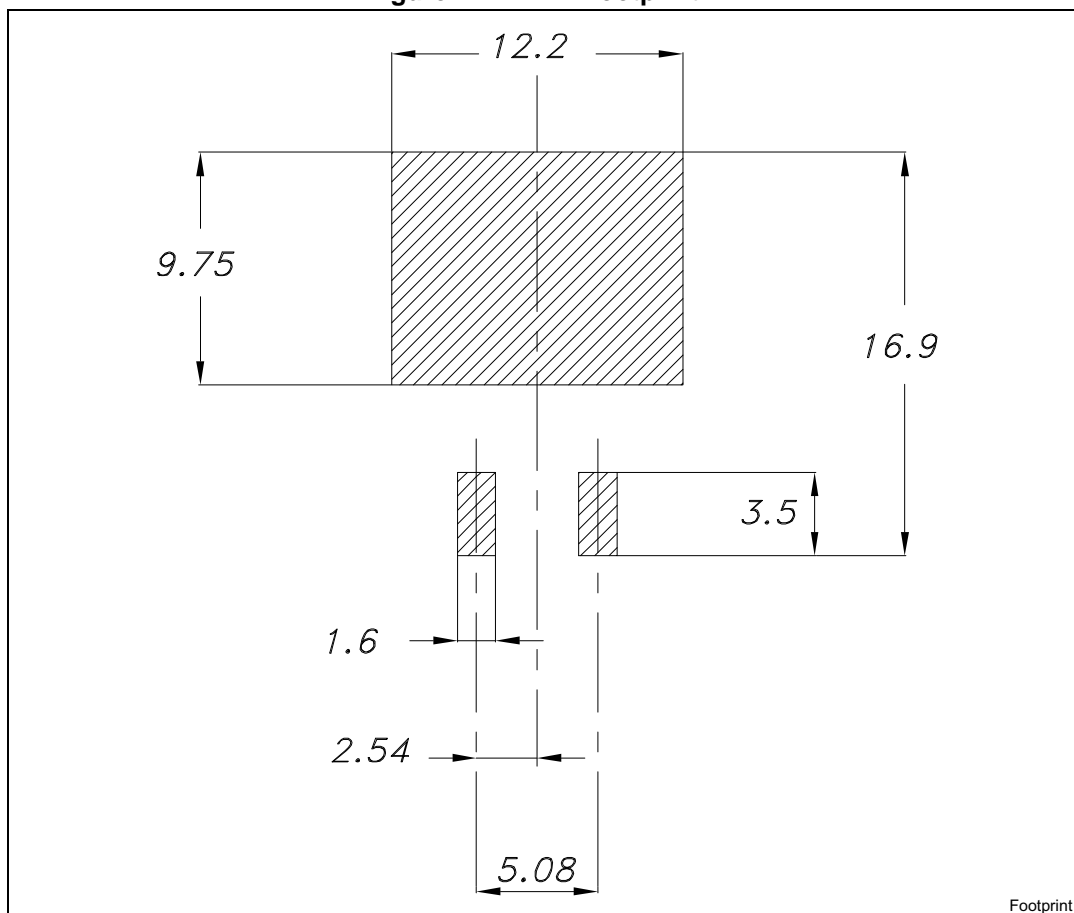

Table 7. D²PAK (TO-263) mechanical data

Dim.	mm		
	Min.	Typ.	Max.
A	4.40		4.60
A1	0.03		0.23
b	0.70		0.93
b2	1.14		1.70
c	0.45		0.60
c2	1.23		1.36
D	8.95		9.35
D1	7.50	7.75	8.00
D2	1.10	1.30	1.50
E	10		10.40
E1	8.50	8.70	8.90
E2	6.85	7.05	7.25
e		2.54	
e1	4.88		5.28
H	15		15.85
J1	2.49		2.69
L	2.29		2.79
L1	1.27		1.40
L2	1.30		1.75
R		0.4	
V2	0°		8°

Figure 21. D²PAK footprint^(a)



a. All dimension are in millimeters

4.2 TO-220 package information

Figure 22. TO-220 type A outline

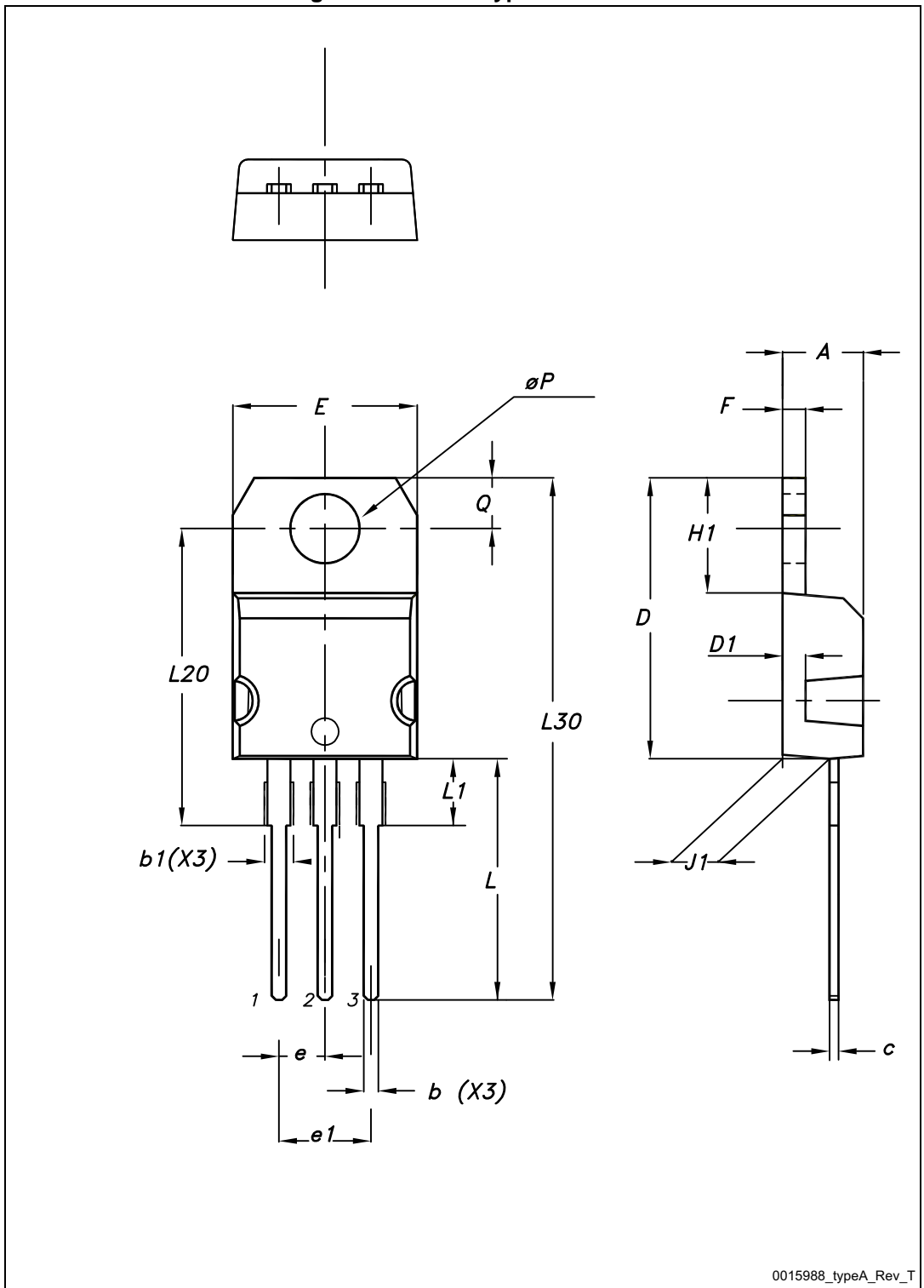

0015988_typeA_Rev_T

Table 8. TO-220 type A mechanical data

Dim.	mm		
	Min.	Typ.	Max.
A	4.40		4.60
b	0.61		0.88
b1	1.14		1.70
c	0.48		0.70
D	15.25		15.75
D1		1.27	
E	10		10.40
e	2.40		2.70
e1	4.95		5.15
F	1.23		1.32
H1	6.20		6.60
J1	2.40		2.72
L	13		14
L1	3.50		3.93
L20		16.40	
L30		28.90	
øP	3.75		3.85
Q	2.65		2.95

5 Packing information

Table 9. D²PAK (TO-263) tape and reel mechanical data

Tape			Reel		
Dim.	mm		Dim.	mm	
	Min.	Max.		Min.	Max.
A0	10.5	10.7	A		330
B0	15.7	15.9	B	1.5	
D	1.5	1.6	C	12.8	13.2
D1	1.59	1.61	D	20.2	
E	1.65	1.85	G	24.4	26.4
F	11.4	11.6	N	100	
K0	4.8	5.0	T		30.4
P0	3.9	4.1			
P1	11.9	12.1	Base qty		1000
P2	1.9	2.1	Bulk qty		1000
R	50				
T	0.25	0.35			
W	23.7	24.3			

Figure 23. Tape

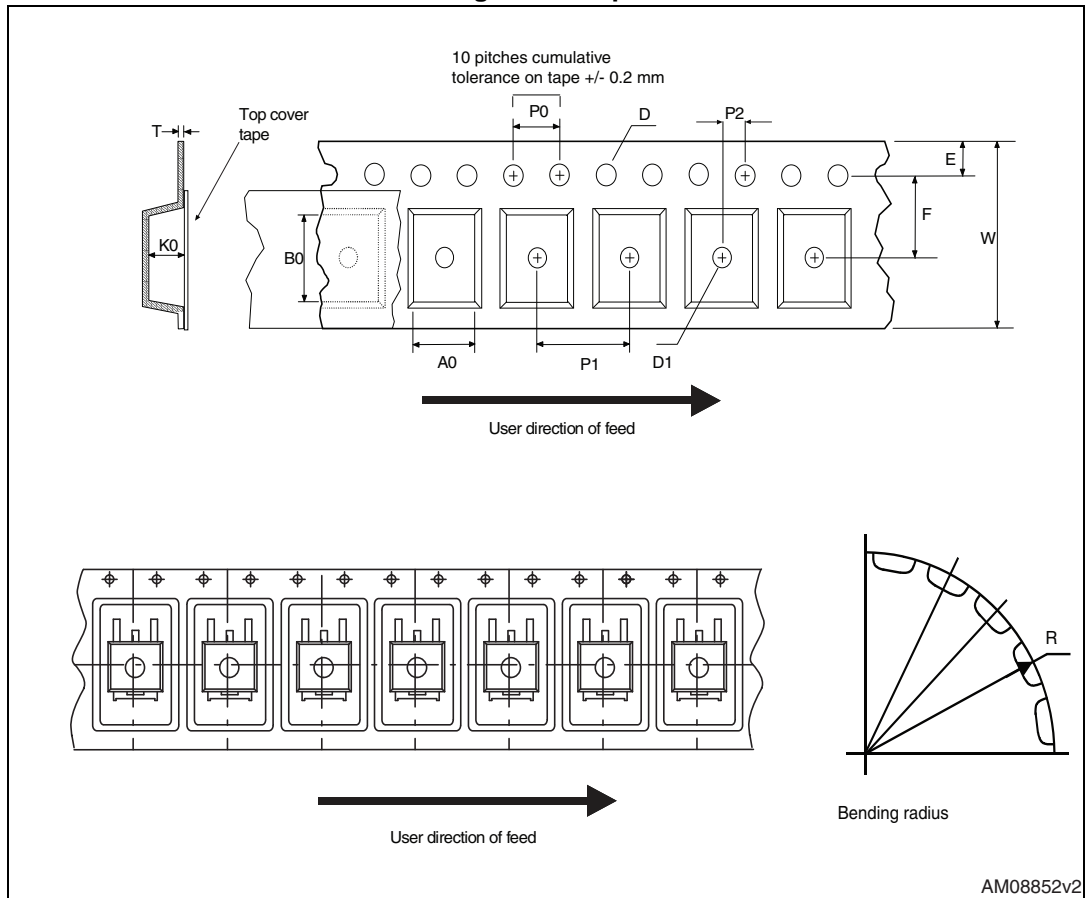
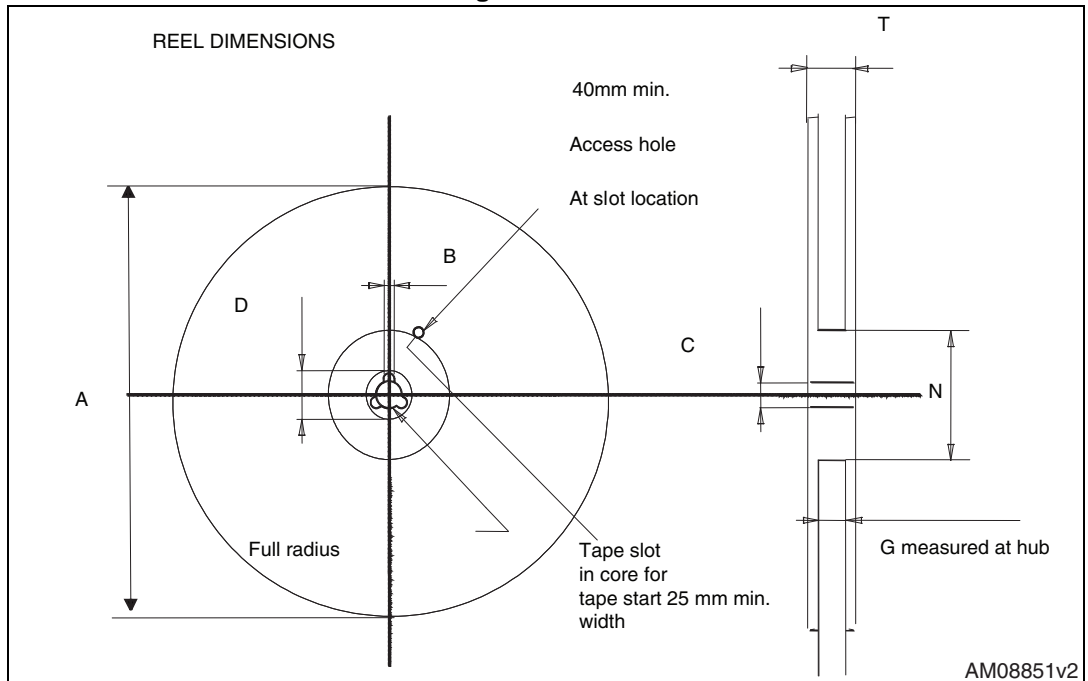

Figure 24. Reel



6 Revision history

Table 10. Document revision history

Date	Revision	Changes
05-Aug-2010	1	Initial release.
02-Sep-2010	2	Updated title on cover page and Table 4: On/off states .
07-Apr-2011	3	Document status promoted from preliminary data to datasheet.
10-Oct-2011	4	Inserted new device in D ² PAK: Updated: Table 2: Absolute maximum ratings , Table 3: Thermal data and Section 4: Package information with the new device. Inserted Section 5: Packing information . Minor text changes.
12-Dec-2011	5	<ul style="list-style-type: none"> – Figure 9: Output capacitance stored energy has been updated. – Figure 10: Normalized gate threshold voltage vs temperature has been updated. – Figure 11: Normalized on-resistance vs temperature has been updated. – Figure 12: Normalized B_{VDSS} vs temperature has been updated.
21-Dec-2011	6	Updated: Table 2: Absolute maximum ratings (V_{ISO} value for TO-220FP)
10-May-2012	7	Figure 6: Gate charge vs gate-source voltage has been updated.
01-Jul-2013	8	<ul style="list-style-type: none"> – The part number STP34NM60N has been moved to a separate datasheet. – Added: MOSFET ruggedness parameter and 3 on Table 2 – Modified: I_D value on Table 5 and typical values for $t_{d(on)}$, t_r, $t_{d(off)}$ and t_f, max values for I_{SD} and I_{SDM}, I_{SD} for V_{SD}, typical value and I_{SD} for t_{rr} – Modified: Figure 6, 7, 12 and 13 – Minor text changes
20-Mar-2015	9	<ul style="list-style-type: none"> – The part number STW34NM60N has been moved to a separate datasheet. – Updated Section 4: Package information. – Minor text changes.

IMPORTANT NOTICE – PLEASE READ CAREFULLY

STMicroelectronics NV and its subsidiaries ("ST") reserve the right to make changes, corrections, enhancements, modifications, and improvements to ST products and/or to this document at any time without notice. Purchasers should obtain the latest relevant information on ST products before placing orders. ST products are sold pursuant to ST's terms and conditions of sale in place at the time of order acknowledgement.

Purchasers are solely responsible for the choice, selection, and use of ST products and ST assumes no liability for application assistance or the design of Purchasers' products.

No license, express or implied, to any intellectual property right is granted by ST herein.

Resale of ST products with provisions different from the information set forth herein shall void any warranty granted by ST for such product.



ST and the ST logo are trademarks of ST. All other product or service names are the property of their respective owners.

Information in this document supersedes and replaces information previously supplied in any prior versions of this document.

© 2015 STMicroelectronics – All rights reserved

Looking for pricing, stock, or lifecycle information?

Click below to explore more details on WIN SOURCE:

-  [View STP34NM60N on WIN SOURCE](#)
-  [STMicroelectronics Information](#)

Optimize Your Supply Chain with WIN SOURCE Solutions

-  Global Sourcing Solution
-  Obsolete Management
-  Cost Control Management
-  Shortage Management
-  Alternative Solution
-  Excess Inventory Management