



**THE DATASHEET OF  
ADNS-2120-001**



# ADNS-2120

## Solid-State Optical Mouse Lens



## Data Sheet

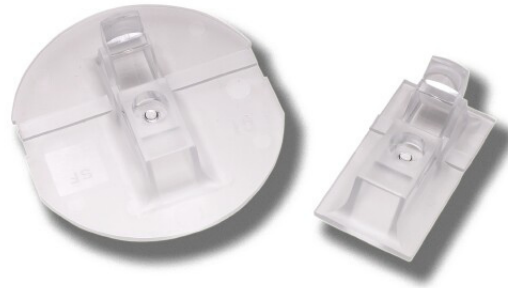

### Description

The ADNS-2120 and ADNS-2120-001 Solid-State Optical Mouse Lens is designed for use with Avago Optical Mouse Sensors and the illumination subsystem provided by the ADNS-2220-001 LED Assembly Clip and the HLMP-ED80-XX000 LED. Together with the LED, the ADNS-2120 and ADNS-2120-001 provide the directed illumination and optical imaging necessary for proper operation of the Optical Mouse Sensor. The lens is a precision molded optical component and should be handled with care to avoid scratching of the optical surfaces.

### Ordering Information

Specify Part Number as follows:

| Flange | Part Number   | Material      |
|--------|---------------|---------------|
| Round  | ADNS-2120     | Polycarbonate |
| Trim   | ADNS-2120-001 | Polycarbonate |

Outline Drawings  
ADNS-2120

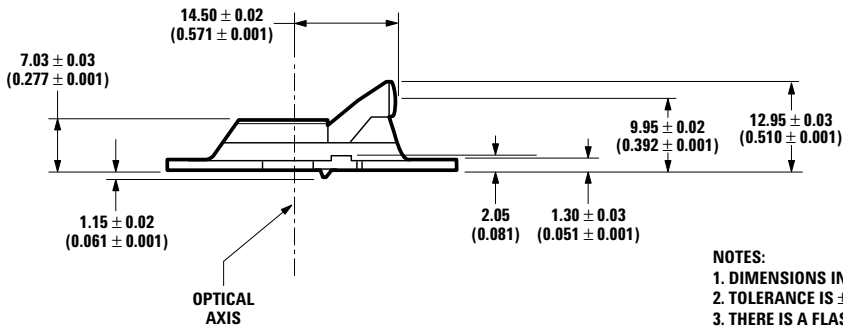
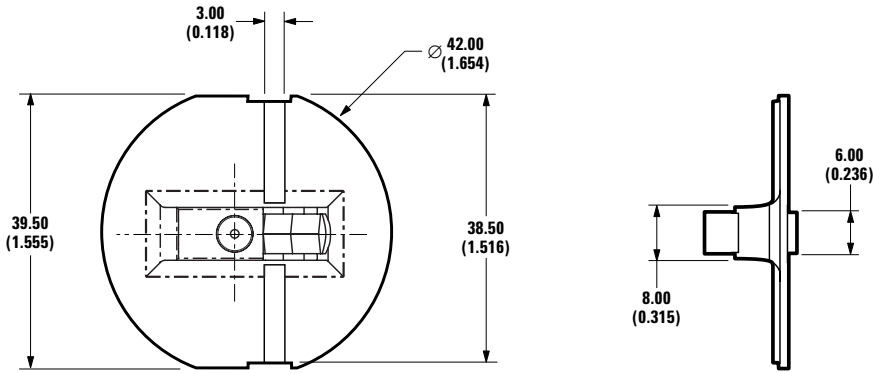

- NOTES:  
1. DIMENSIONS IN MILLIMETERS (INCHES).  
2. TOLERANCE IS ±0.2 mm (±0.79 INCHES) EXCEPT WHERE NOTED.  
3. THERE IS A FLASH TOLERANCE OF 0.2 mm MAX. ON THE FLANGE.

ADNS-2120-001

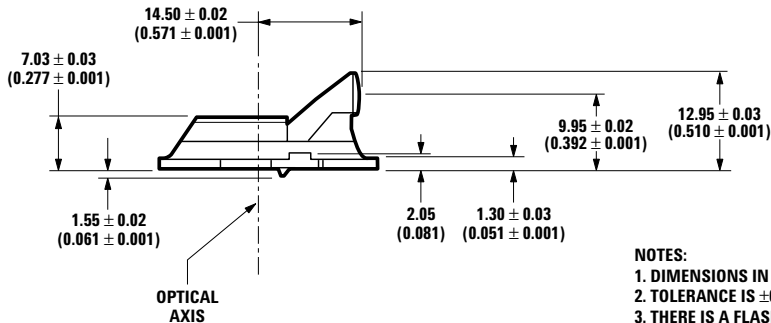
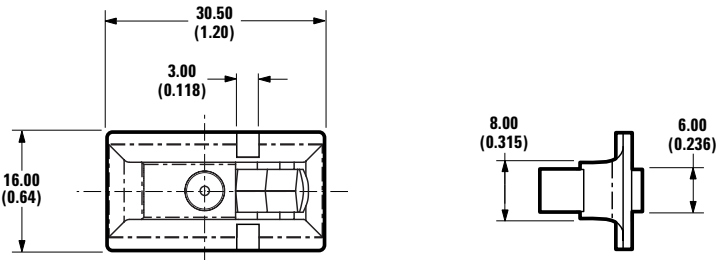

- NOTES:  
1. DIMENSIONS IN MILLIMETERS (INCHES).  
2. TOLERANCE IS ±0.2 mm (±0.79 INCHES) EXCEPT WHERE NOTED.  
3. THERE IS A FLASH TOLERANCE OF 0.2 mm MAX. ON THE FLANGE.

### Mechanical Assemble Requirements

All specifications reference Figure 1, Optical System Assembly Diagram.

| Parameter  | Symbol | Min. | Typical | Max. | Units | Conditions  |
|--|--------|------|---------|------|-------|---|
| Distance from Object Surface to Lens Reference Plane                           | A      | 2.3  | 2.4     | 2.5  | mm    |   |
| Distance from Mouse Sensor Lid Lid contact with lens Surface to Object Surface | B      |      | 9.43    |      | mm    | Sensor lid must be in contact with lens housing surface |

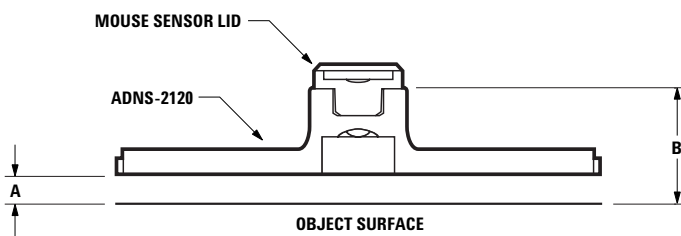
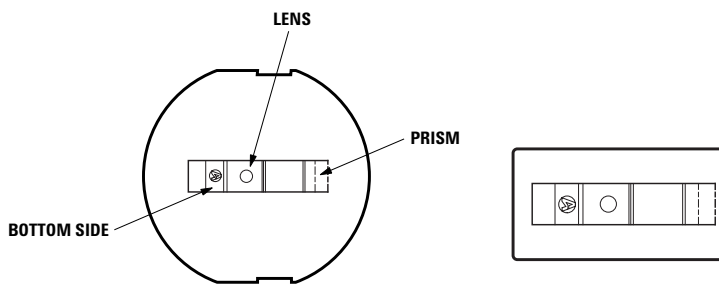

Figure 1. Optical system assembly diagram.



- NOTES:**
1. TOPSIDE LOGO EXTENDS 0.2 mm ABOVE THE FLANGE SURFACE.
  2. BOTTOMSIDE LOGO EXTENDS 0.1 mm BELOW THE SURFACE.
  3. BOTTOMSIDE LOGO IS EITHER LEFT SIDE, AS SHOWN AS ABOVE, OR PRISM SIDE OF THE LENS.

Figure 2. Logo locations.

### Lens Design Optical Performance Specifications

All specifications are based on the Mechanical Assembly Requirements.

| Parameter                         | Symbol    | Min.  | Typical   | Max.   | Units | Conditions                 |
|-----------------------------------|-----------|-------|-----------|--------|-------|----------------------------|
| Numerical Aperture                | NA        | 0.1   | 0.13      | 0.16   |       |                            |
| Magnification                     |           | 0.85  | 1.00      | 1.15   |       | Image at nominal location  |
| Design Wavelength                 | $\lambda$ |       | 639       |        | nm    |                            |
| Object to Image Distance          |           |       | 10.85     |        | mm    |                            |
| Lens Material*Index of Refraction | N         | 1.580 | 1.5818    | 1.5840 |       | $\lambda = 639 \text{ nm}$ |
| Depth of Field                    | DOF       |       | $\pm 0.5$ |        | mm    |                            |
| Field Coverage Radius             |           |       | 1.8       |        | mm    |                            |

\*Lens material is polycarbonate. Cyanoacrylate based adhesives should not be used as they will cause lens material deformation.

### Mounting Instructions for the ADNS-2120 Lens to the Base Plate

An IGES format drawing file with design specifications for mouse base plate features is available.

These features are useful in maintaining proper positioning and alignment of the ADNS-2120 when used with the Avago Optical Mouse Sensor. This file can be obtained by contacting your local Avago sales representative.

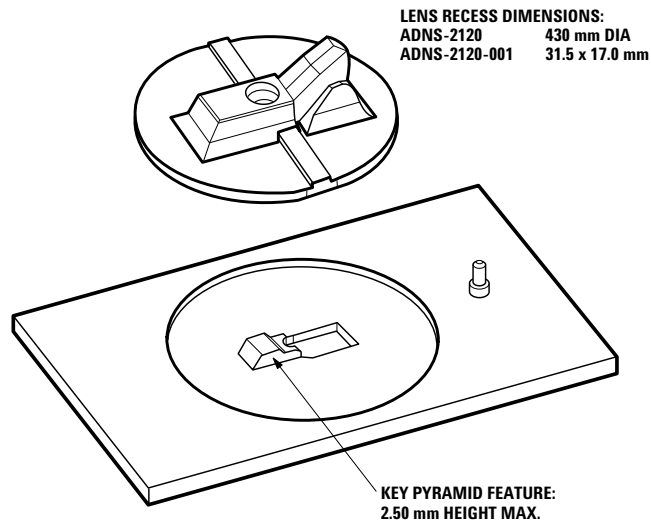

Figure 3. Illustration of base plate mounting features.

**Note:**

ADNS-2120 lens has a large round flange to provide a long creepage path for any ESD events that occur at the opening of the base plate. For improved ESD performance, the lens flange can be sealed (i.e., glued) to the base plate. Note that the lense material is polycarbonate and therefore, cyanoacrylate based adhesives or other adhesives that may damage the lens should NOT be used.

For product information and a complete list of distributors, please go to our website: [www.avagotech.com](http://www.avagotech.com)

Avago, Avago Technologies, and the A logo are trademarks of Avago Technologies Limited in the United States and other countries. Data subject to change. Copyright © 2005-2008 Avago Technologies Limited. All rights reserved. Obsoletes 5989-1238EN AV02-1256EN - May 13, 2008



## Looking for pricing, stock, or lifecycle information?

Click below to explore more details on WIN SOURCE:

 [View ADNS-2120-001 on WIN SOURCE](#)

 [Broadcom Limited](#) Information

## Optimize Your Supply Chain with WIN SOURCE Solutions

-  Global Sourcing Solution
-  Obsolete Management
-  Cost Control Management
-  Shortage Management
-  Alternative Solution
-  Excess Inventory Management