



**THE DATASHEET OF
DLPA3000DPFDR**



DLPA3000 PMIC and High-Current LED Driver IC

1 Features

- High-efficiency, high-current RGB LED driver
- Integrated buck converter enables up to 6-A LED driver current
- RGB MOSFET switches for channel selection with very low on-resistance
- 10-bit programmable current per channel
- Inputs for selecting color-sequential RGB LEDs
- Generation of DMD high-voltage supplies
- Two high-efficiency buck converters to generate the DLPC343x and DMD supply
- One high-efficiency, 8-bit programmable buck converter for FAN driver application or general power supply. General purpose buck2 (PWR6) is currently supported.
- Two LDOs supplying auxiliary voltages
- Analog MUX for measuring internal and external nodes such as a thermistor and reference levels
- Monitoring/protections: thermal shutdown, hot die, low-battery, and undervoltage lockout (UVLO)

2 Applications

- [Portable DLP®Pico™ projectors](#)

3 Description

The DLPA3000 is a highly integrated power management IC optimized for DLP® Pico Projector systems. The device is targeting accessory applications up to several hundreds of lumens.

The DLPA3000 supports LED projectors up to 6 A per LED, enabled by an integrated high efficiency buck converter. Additionally, the low-ohmic RGB switches support the sequencing of red, green, and blue LEDs. The DLPA3000 contains five buck converters with two dedicated for DLPC low-voltage supplies. Another dedicated regulating supply generates the three timing-critical DC supplies for the DMD: V_{BIAS} , V_{RST} , and V_{OFS} .

The DLPA3000 contains several auxiliary blocks that can be used in a flexible way. This enables a tailor-made Pico projector system. One 8-bit programmable buck converter can be used, for example, to drive the projector FAN or to make auxiliary supply lines. General purpose buck2 (PWR6) is currently supported. Two LDOs can be used for a lower-current supply of up to 200 mA. These LDOs are predefined to 2.5 V and 3.3 V.

Device Information

PART NUMBER	PACKAGE ⁽¹⁾	PACKAGE SIZE (NOM)
DLPA3000	HTQFP (100)	14.00 mm × 14.00 mm

(1) For all available packages, see the orderable addendum at the end of the data sheet.

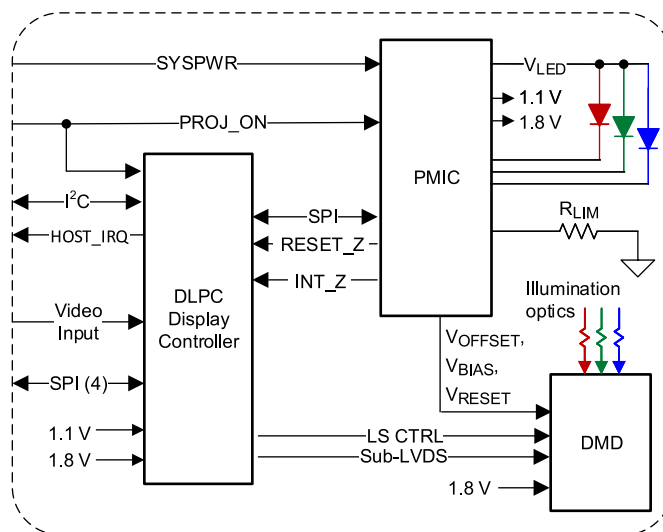

Typical, Simplified System



Table of Contents

1 Features	1	9.2 Typical Applications.....	46
2 Applications	1	10 Power Supply Recommendations	49
3 Description	1	11 Layout	50
4 Revision History	2	11.1 Layout Guidelines.....	50
5 Description (cont.)	4	11.2 Layout Example.....	50
6 Pin Configuration and Functions	4	11.3 SPI Connections.....	51
7 Specifications	8	11.4 R _{LIM} Routing.....	52
7.1 Absolute Maximum Ratings.....	8	11.5 LED Connection.....	52
7.2 ESD Ratings.....	9	11.6 Thermal Considerations.....	53
7.3 Recommended Operating Conditions.....	9	12 Device and Documentation Support	56
7.4 Thermal Information.....	9	12.1 Third-Party Products Disclaimer.....	56
7.5 Electrical Characteristics.....	10	12.2 Device Support.....	56
7.6 SPI Timing Parameters.....	16	12.3 Related Links.....	56
8 Detailed Description	17	12.4 Receiving Notification of Documentation Updates.....	56
8.1 Overview.....	17	12.5 Support Resources.....	56
8.2 Functional Block Diagram.....	17	12.6 Trademarks.....	57
8.3 Feature Description.....	17	12.7 Support Resources.....	57
8.4 Device Functional Modes.....	40	12.8 Electrostatic Discharge Caution.....	57
8.5 Register Maps.....	42	12.9 Glossary.....	57
9 Application and Implementation	46	13 Mechanical, Packaging, and Orderable Information	58
9.1 Application Information.....	46		

4 Revision History

NOTE: Page numbers for previous revisions may differ from page numbers in the current version.

Changes from Revision * (October 2015) to Revision A (September 2023)	Page
• Removed unsupported General Purpose Buck Converters in Features	1
• Updated this data sheet per the latest industry and Texas Instruments standards.....	1
• Removed unsupported buck converters, and updated System Block Diagram in Description	1
• Updated Pin Configuration and Functions	4
• Updated Section 7.3	9
• Updated Electrical Characteristics	10
• Removed unsupported general purpose buck converters in Overview	17
• Updated Functional Block Diagram	17
• Removed unsupported general purpose buck converters in Supply	17
• Updated register names in Monitoring	19
• Updated Block Faults	20
• Updated register names in Low Battery and UVLO	20
• Updated LDO Illum	22
• Updated Break Before Make (BBM)	25
• Updated LDO DMD	28
• Removed unsupported general purpose buck converters 1 and 3 in Buck Converters	34
• Removed unsupported general purpose buck converters in LDO Bucks	34
• Removed unsupported general purpose buck converters 1 and 3 in General Purpose Buck Converters	34
• Removed unsupported General Purpose Buck Converters 1 and 3 in Buck Converter Monitoring	36
• Removed unsupported General Purpose Buck Converters 1 and 3 in Power Good	36
• Updated Overvoltage Fault	36
• Removed light sensor use-case in Measurement System	37
• Added the SPI Timing Diagram in SPI	38
• Removed unsupported general purpose buck converters in Interrupt	38
• Updated Register Maps	42
• Updated the System Block Diagram in Typical Application Setup Using DLPA3000	46
• Updated Typical Application with DLPA3000 Internal Block Diagram	48

• Updated Layout Guidelines	50
• Updated Layout Example	50
• Removed unsupported general purpose buck converter in SPI Connections	51
• Updated R_{LIM} Routing	52
• Updated Section 11.5	52
• Updated Thermal Considerations	53

5 Description (cont.)

Through the SPI, all blocks of the DLPA3000 can be addressed. Features included are the generation of the system reset, power sequencing, input signals for sequentially selecting the active LED, IC self-protections, and an analog MUX for routing analog information to an external ADC.

6 Pin Configuration and Functions

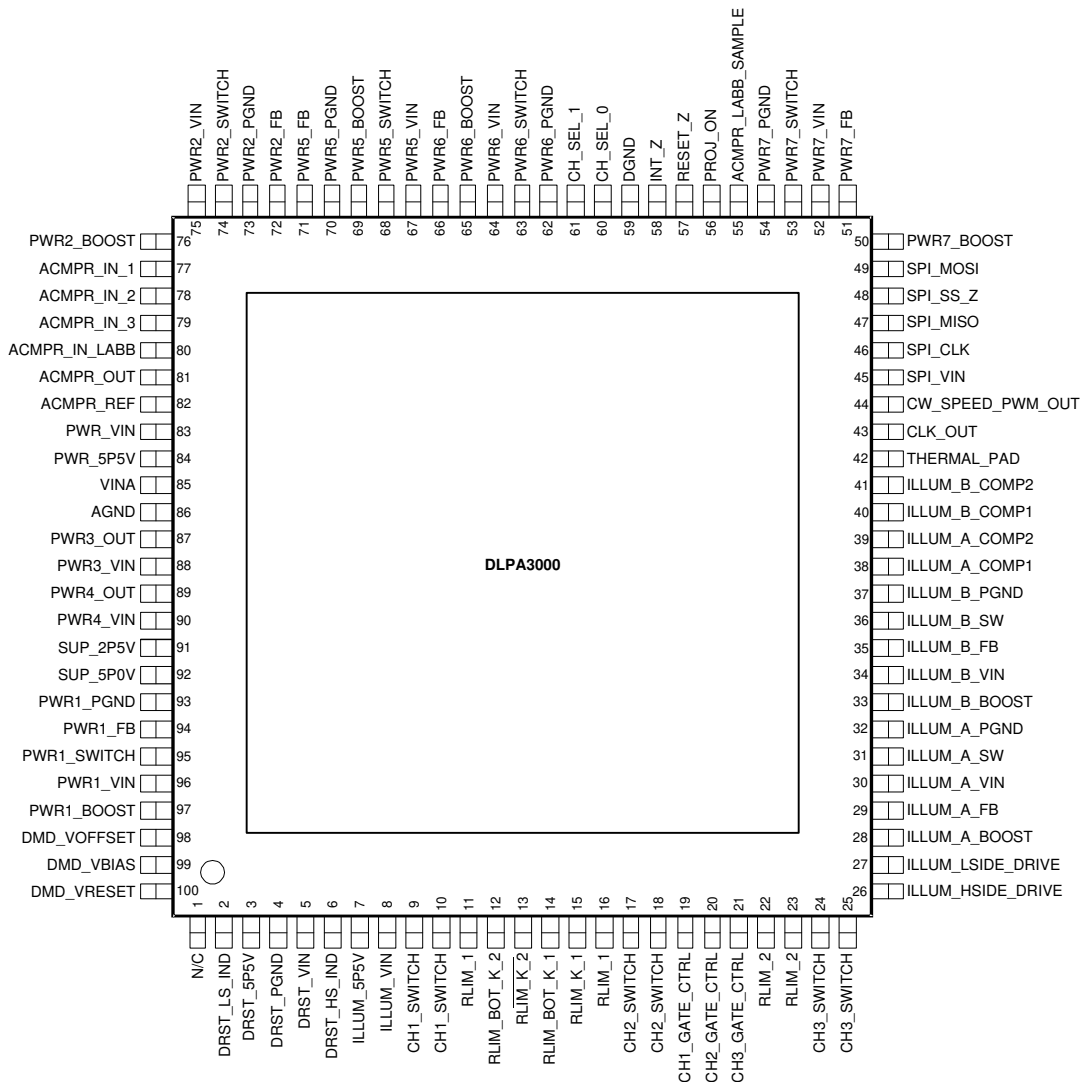

Figure 6-1. PFD Package 100-Pin HTQFP Top View

Table 6-1. Pin Functions

PIN		I/O	DESCRIPTION
NAME	NO.		
N/C	1	—	No connect
DRST_LS_IND	2	I/O	Connection for the DMD SMPS-inductor (low-side switch)
DRST_5P5V	3	O	Filter pin for LDO DMD. Power supply for internal DMD reset regulator, typical 5.5 V
DRST_PGND	4	GND	Power ground for DMD SMPS. Connect to ground plane.
DRST_VIN	5	POWER	Power supply input for LDO DMD. Connect to system power.
DRST_HS_IND	6	I/O	Connection for the DMD SMPS-inductor (high-side switch)
ILLUM_5P5 V	7	O	Filter pin for LDO ILLUM. Power supply for internal ILLUM block, typical 5.5 V

Table 6-1. Pin Functions (continued)

PIN		I/O	DESCRIPTION
NAME	NO.		
ILLUM_VIN	8	POWER	Supply input of LDO ILLUM. Connect to system power.
CH1_SWITCH	9	I	Low-side MOSFET switch for LED Cathode. Connect to RGB LED assembly.
CH1_SWITCH	10	I	Low-side MOSFET switch for LED Cathode. Connect to RGB LED assembly.
RLIM_1	11	O	Connection to LED current sense resistor for CH1 and CH2
RLIM_BOT_K_2	12	I	Kelvin sense connection to ground side of LED current sense resistor
RLIM_K_2	13	I	Kelvin sense connection to top side of current sense resistor
RLIM_BOT_K_1	14	I	Kelvin sense connection to ground side of LED current sense resistor
RLIM_K_1	15	I	Kelvin sense connection to top side of current sense resistor
RLIM_1	16	O	Connection to LED current sense resistor for CH1 and CH2
CH2_SWITCH	17	I	Low-side MOSFET switch for LED cathode. Connect to RGB LED assembly.
CH2_SWITCH	18	I	Low-side MOSFET switch for LED cathode. Connect to RGB LED assembly.
CH1_GATE_CTRL	19	O	Gate control of CH1 external MOSFET switch for LED cathode
CH2_GATE_CTRL	20	O	Gate control of CH2 external MOSFET switch for LED cathode
CH3_GATE_CTRL	21	O	Gate control of CH3 external MOSFET switch for LED cathode
RLIM_2	22	O	Connection to LED current sense resistor for CH3
RLIM_2	23	O	Connection to LED current sense resistor for CH3
CH3_SWITCH	24	I	Low-side MOSFET switch for LED Cathode. Connect to RGB LED assembly.
CH3_SWITCH	25	I	Low-side MOSFET switch for LED Cathode. Connect to RGB LED assembly.
ILLUM_HSIDE_DRIVE	26	O	Gate control for external high-side MOSFET for ILLUM Buck converter
ILLUM_LSIDE_DRIVE	27	O	Gate control for external low-side MOSFET for ILLUM Buck converter
ILLUM_A_BOOST	28	I	Supply voltage for high-side N-channel MOSFET gate driver. A-100 nF capacitor (typical) must be connected between this pin and ILLUM_A_SW.
ILLUM_A_FB	29	I	Input to the buck converter loop controlling I_{LED}
ILLUM_A_VIN	30	POWER	Power input to the ILLUM Driver A
ILLUM_A_SW	31	I/O	Switch node connection between high-side NFET and low-side NFET. Serves as common connection for the flying high side FET driver
ILLUM_A_PGND	32	GND	Ground connection to the ILLUM Driver A
ILLUM_B_BOOST	33	I	Supply voltage for high-side N-channel MOSFET gate driver
ILLUM_B_VIN	34	POWER	Power input to the ILLUM driver B
ILLUM_B_FB	35	I	Input to the buck converter loop controlling I_{LED}
ILLUM_B_SW	36	I/O	Switch node connection between high-side NFET and low-side NFET
ILLUM_B_PGND	37	GND	Ground connection to the ILLUM driver B
ILLUM_A_COMP1	38	I/O	Connection node for feedback loop components
ILLUM_A_COMP2	39	I/O	Connection node for feedback loop components
ILLUM_B_COMP1	40	I/O	Connection node for feedback loop components
ILLUM_B_COMP2	41	I/O	Connection node for feedback loop components
THERMAL_PAD	42	GND	Thermal pad. Connect to clean system ground.
CLK_OUT	43	O	No connect. Reserved for color wheel clock output
CW_SPEED_PWM_OUT	44	O	No connect. Reserved for color wheel PWM output
SPI_VIN	45	I	Supply for SPI interface
SPI_CLK	46	I	SPI clock input
SPI_MISO	47	O	SPI data output
SPI_SS_Z	48	I	SPI chip select (active low)
SPI_MOSI	49	I	SPI data input

Table 6-1. Pin Functions (continued)

PIN		I/O	DESCRIPTION
NAME	NO.		
PWR7_BOOST	50	I	Reserved for general purpose buck converter. Charge-pump-supply input for the high-side FET gate drive circuit. Connect a 100 nF-capacitor between PWR7_BOOST and PWR7_SWITCH pins.
PWR7_FB	51	I	Reserved for general purpose buck converter. Converter feedback input. Connect to converter output voltage.
PWR7_VIN	52	POWER	Reserved for general purpose buck converter. Power supply input for converter
PWR7_SWITCH	53	I/O	Reserved for general purpose buck converter. Switch node connection between high-side NFET and low-side NFET
PWR7_PGND	54	GND	Reserved for general purpose buck converter. Ground pin. Power ground return for switching circuit
ACMPR_LABB_SAMPLE	55	I	Control signal to sample voltage at ACMPR_IN_LABB
PROJ_ON	56	I	Input signal to enable/disable the IC and DLP projector
RESET_Z	57	O	Reset output to the DLP system (active low). Pin is held low to reset DLP system.
INT_Z	58	O	Interrupt output signal (open drain, active low). Connect to pullup resistor.
DGND	59	GND	Digital ground. Connect to ground plane.
CH_SEL_0	60	I	Control signal to enable either of CH1,2,3
CH_SEL_1	61	I	Control signal to enable either of CH1,2,3
PWR6_PGND	62	GND	Ground pin. Power ground return for switching circuit
PWR6_SWITCH	63	I/O	Switch node connection between high-side NFET and low-side NFET
PWR6_VIN	64	POWER	Power supply input for converter
PWR6_BOOST	65	I	Charge-pump-supply input for the high-side FET gate drive circuit. Connect 100-nF capacitor between PWR6_BOOST and PWR6_SWITCH pins.
PWR6_FB	66	I	Converter feedback input. Connect to output voltage.
PWR5_VIN	67	POWER	Reserved for general purpose buck converter. Power supply input for converter
PWR5_SWITCH	68	I/O	Reserved for general purpose buck converter. Switch node connection between high-side NFET and low-side NFET
PWR5_BOOST	69	I	Reserved for general purpose buck converter. Charge-pump-supply input for the high-side FET gate drive circuit. Connect 100-nF capacitor between PWR5_BOOST and PWR5_SWITCH pins.
PWR5_PGND	70	GND	Reserved for general purpose buck converter. Ground pin. Power ground return for switching circuit
PWR5_FB	71	I	Reserved for general purpose buck converter. Converter feedback input. Connect to output voltage.
PWR2_FB	72	I	Converter feedback input. Connect to output voltage.
PWR2_PGND	73	GND	Ground pin. Power ground return for switching circuit
PWR2_SWITCH	74	I/O	Switch node connection between high-side NFET and low-side NFET
PWR2_VIN	75	POWER	Power supply input for converter
PWR2_BOOST	76	I	Charge-pump-supply input for the high-side FET gate drive circuit. Connect 100-nF capacitor between PWR2_BOOST and PWR2_SWITCH pins.
ACMPR_IN_1	77	I	Reserved. Input for analog sensor signal
ACMPR_IN_2	78	I	Input for analog sensor signal
ACMPR_IN_3	79	I	Input for analog sensor signal
ACMPR_IN_LABB	80	I	Input for ambient light sensor, sampled input
ACMPR_OUT	81	O	Analog comparator out
ACMPR_REF	82	I	Reference voltage input for analog comparator
PWR_VIN	83	POWER	Power supply input for LDO_Bucks. Connect to system power.
PWR_5P5V	84	O	Filter pin for LDO_BUCKS. Internal analog supply for buck converters, typical 5.5 V
VINA	85	POWER	Input voltage supply pin for reference system

Table 6-1. Pin Functions (continued)

PIN		I/O	DESCRIPTION
NAME	NO.		
AGND	86	GND	Analog ground pin
PWR3_OUT	87	O	Filter pin for LDO_2 DMD/DLPC/AUX, typical 2.5 V
PWR3_VIN	88	POWER	Power supply input for LDO_2. Connect to system power.
PWR4_OUT	89	O	Filter pin for LDO_1 DMD/DLPC/AUX, typical 3.3 V
PWR4_VIN	90	POWER	Power supply input for LDO_1. Connect to system power.
SUP_2P5V	91	O	Filter pin for LDO_V2V5. Internal supply voltage, typical 2.5 V
SUP_5P0V	92	O	Filter pin for LDO_V5V. Internal supply voltage, typical 5 V
PWR1_PGND	93	GND	Ground pin. Power ground return for switching circuit
PWR1_FB	94	I	Converter feedback input. Connect to output voltage.
PWR1_SWITCH	95	I/O	Switch node connection between high-side NFET and low-side NFET
PWR1_VIN	96	POWER	Power supply input for converter
PWR1_BOOST	97	I	Charge-pump-supply input for the high-side FET gate drive circuit. Connect 100-nF capacitor between PWR1_BOOST and PWR1_SWITCH pins.
DMD_VOFFSET	98	O	VOFS output rail. Connect to ceramic capacitor.
DMD_VBIAS	99	O	VBIAS output rail. Connect to ceramic capacitor.
DMD_VRESET	100	O	VRESET output rail. Connect to ceramic capacitor.

7 Specifications

7.1 Absolute Maximum Ratings

over operating free-air temperature (unless otherwise noted) ⁽¹⁾

		MIN	MAX	UNIT
Voltage	ILLUM_A,B_BOOST	-0.3	28	V
	ILLUM_A,B_BOOST (10 ns transient)	-0.3	30	
	ILLUM_A,B_BOOST vs ILLUM_A,B_SWITCH	-0.3	7	
	ILLUM_LSIDE_DRIVE	-0.3	7	
	ILLUM_HSIDE_DRIVE	-2	28	
	ILLUM_A_BOOST vs ILLUM_HSIDE_DRIVE	-0.3	7	
	ILLUM_A,B_SW	-2	22	
	ILLUM_A,B_SW (10 ns transient)	-3	27	
	PWR_VIN, PWR1,2,3,4,5,6,7_VIN, VINA, ILLUM_VIN, ILLUM_A,B_VIN, DRST_VIN	-0.3	22	
	PWR1,2,5,6,7_BOOST	-0.3	28	
	PWR1,2,5,6,7_BOOST (10 ns transient)	-0.3	30	
	PWR1,2,5,6,7_SWITCH	-2	22	
	PWR1,2,5,6,7_SWITCH (10 ns transient)	-3	27	
	PWR1,2,5,6,7_FB	-0.3	6.5	
	PWR1,2,5,6,7_BOOST vs PWR1,2,5,6,7_SWITCH	-0.3	6.5	
	CH1,2,3_SWITCH, DRST_LS_IND, ILLUM_A,B_FB	-0.3	20	
	ILLUM_A,B_COMP1,2, INT_Z, PROJ_ON	-0.3	7	
	DRST_HS_IND	-18	7	
	ACMPR_IN_1,2,3, ACMPR_REF, ACMPR_IN_LABB, ACMPR_LABB_SAMPLE, ACMPR_OUT	-0.3	3.6	
	SPI_VIN, SPI_CLK, SPI_MOSI, SPI_SS_Z, SPI_MISO, CH_SEL_0,1, RESET_Z	-0.3	3.6	
	RLIM_K_1,2, RLIM_1,2	-0.3	3.6	
	DGND, AGND, DRST_PGND, ILLUM_A,B_PGND, PWR1,2,5,6,7_PGND, RLIM_BOT_K_1,2	-0.3	0.3	
	DRST_5P5V, ILLUM_5P5V, PWR_5P5, PWR3,4_OUT, SUP_5P0V	-0.3	7	
	CH1,2,3_GATE_CTRL	-0.3	7	
	CLK_OUT	-0.3	3.6	
	CW_SPEED_PWM	-0.3	7	
	SUP_2P5V	-0.3	3.6	
DMD_VOFFSET	-0.3	12		
DMD_VBIAS	-0.3	20		
DMD_VRESET	-18	7		
Source current	RESET_Z, ACMPR_OUT		1	mA
	SPI_DOUT		5.5	
Sink current	RESET_Z, ACMPR_OUT		1	mA
	SPI_DOUT, INT_Z		5.5	
T _{stg}	Storage temperature	-65	150	°C

- (1) Operation outside the Absolute Maximum Ratings may cause permanent device damage. Absolute Maximum Ratings do not imply functional operation of the device at these or any other conditions beyond those listed under Recommended Operating Conditions. If outside the Recommended Operating Conditions but within the Absolute Maximum Ratings, the device may not be fully functional, and this may affect device reliability, functionality, performance, and shorten the device lifetime.

7.2 ESD Ratings

		VALUE	UNIT
$V_{(ESD)}$ (1)	Electrostatic discharge	Human-body model (HBM), per ANSI/ESDA/JEDEC JS-001, all pins(2)	±2000
		Charged-device model (CDM), per JEDEC specification JESD22-C101, all pins(3)	±500

- (1) Electrostatic discharge (ESD) to measure device sensitivity and immunity to damage caused by assembly line electrostatic discharges in to the device.
(2) JEDEC document JEP155 states that 500 V HBM allows safe manufacturing with a standard ESD control process.
(3) JEDEC document JEP157 states that 250 V CDM allows safe manufacturing with a standard ESD control process.

7.3 Recommended Operating Conditions

over operating free-air temperature range (unless otherwise noted)

		MIN	MAX	UNIT	
V_i	Input voltage	PWR_VIN, PWR1,2,3,4,5,6,7_VIN, VINA, ILLUM_VIN, ILLUM_A,B_VIN, DRST_VIN	6	20	V
		CH1,2,3_SWITCH, ILLUM_A,B_FB,	-0.1	20	
		PROJ_ON	-0.1	6	
		PWR1,2,5,6,7_FB	-0.1	5	
		ACMPR_REF, CH_SEL_0,1, SPI_CLK, SPI_MOSI, SPI_SS_Z	-0.1	3.6	
		RLIM_BOT_K_1,2	-0.1	0.1	
		ACMPR_IN_1,2,3, LABB_IN_LABB	-0.1	1.5	
		SPI_VIN	1.7	3.6	
		RLIM_K_1,2	-0.1	0.25	
	ILLUM_A,B_COMP1,2	-0.1	5.7		
T_A	Ambient temperature	0	70	°C	
T_J	Operating junction temperature	0	120	°C	

7.4 Thermal Information

THERMAL METRIC(1)		DLPA3000	UNIT
		HTQFP (PFD)	
		100 PINS	
$R_{\theta JA}$	Junction-to-ambient thermal resistance (2)	7.0	°C/W
$R_{\theta JC(top)}$	Junction-to-case (top) thermal resistance (3)	0.7	°C/W
ψ_{JT}	Junction-to-top characterization parameter (4)	0.6	°C/W
ψ_{JB}	Junction-to-board characterization parameter (5)	3.4	°C/W

- (1) For more information about traditional and new thermal metrics, see the *Semiconductor and IC Package Thermal Metrics* application report (SPRA953).
(2) The junction-to-ambient thermal resistance under natural convection is obtained in a simulation on a JEDEC-standard, high-K board, but since the device is intended to be cooled with a heatsink from the top case of the package, the simulation includes a fan and heatsink attached to the DLPA3000. The heatsink is a 22 mm × 22 mm × 12 mm aluminum pin fin heatsink with a 12 × 12 × 3 mm stud. Base thickness is 2 mm and pin diameter is 1.5 mm with an array of 6 × 6 pins. The heatsink is attached to the DLPA3000 with 100 um thick thermal grease with 3 W/m-K thermal conductivity. The fan is 20 × 20 × 8 mm with 1.6 cfm open volume flow rate and 0.22 in. water pressure at stagnation.
(3) The junction-to-case (top) thermal resistance is obtained by simulating a cold plate test on the package top. No specific JEDEC standard test exists, but a close description can be found in the ANSI SEMI standard G30-88.
(4) The junction-to-top characterization parameter, ψ_{JT} , estimates the junction temperature of a device in a real system and is extracted from the simulation data for obtaining $R_{\theta JA}$, using a procedure described in JESD51-2a (sections 6 and 7), but modified to include the fan and heatsink described in note 2.
(5) The junction-to-board characterization parameter, ψ_{JB} , estimates the junction temperature of a device in a real system and is extracted from the simulation data for obtaining $R_{\theta JA}$, using a procedure described in JESD51-2a (sections 6 and 7), but modified to include the fan and heatsink described in note 2.

7.5 Electrical Characteristics

over operating free-air temperature range. $V_{IN} = 12\text{ V}$, $T_A = 0$ to $+70^\circ\text{C}$, typical values are at $T_A = 25^\circ\text{C}$, configuration according to *Typical Applications* ($V_{IN} = 12\text{ V}$, $I_{OUT} = 6\text{ A}$, LED, internal FETs) (unless otherwise noted).

PARAMETER		TEST CONDITIONS	MIN	TYP	MAX	UNIT
SUPPLIES						
INPUT VOLTAGE						
V_{IN}	Input voltage range	VINA – pin	6 ⁽⁵⁾	12	20	V
V_{LOW_BAT}	Low battery warning threshold	VINA falling (through a 5-bit trim function)	3.9		18.4	V
	Hysteresis	VINA rising		90		mV
V_{UVLO} ⁽⁶⁾	UVLO threshold	VINA falling (through a 5-bit trim function)	3.9	6.22	18.4	V
	Hysteresis	VINA rising		90		mV
$V_{STARTUP}$	Startup voltage	DMD_VBIAS, DMD_VOFFSET, DMD_VRESET loaded with 10 mA	6			V
INPUT CURRENT						
I_{IDLE}	Idle current	IDLE mode, all VIN pins combined		15		μA
I_{STD}	Standby current	STANDBY mode, analog, internal supplies and LDOs enabled, DMD, ILLUMINATION and BUCK CONVERTERS disabled		3.7		mA
I_{Q_DMD}	Quiescent current (DMD)	Quiescent current DMD block (in addition to I_{STD}), VINA + DRST_VIN		0.49		mA
I_{Q_ILLUM}	Quiescent current (ILLUM)	Quiescent current ILLUM block (in addition to I_{STD}) in 6 A LED configuration, internal FETs, $V_{openloop} = 3\text{ V}$ (, VINA + ILLUM_VIN + ILLUM_A_VIN + ILLUM_B_VIN		21		mA
I_{Q_BUCK}	Quiescent current (per BUCK)	Quiescent current per BUCK converter (in addition to I_{STD}), Normal mode, VINA + PWR_VIN + PWR1,2,5,6,7_VIN, PWR1,2,5,6,7_VOUT = 1 V		4.3		mA
		Quiescent current per BUCK converter (in addition to I_{STD}), Normal mode, VINA + PWR_VIN + PWR1,2,5,6,7_VIN, PWR1,2,5,6,7_VOUT = 5 V		15		
		Quiescent current per BUCK converter (in addition to I_{STD}), Cycle-skipping mode, VINA + PWR_VIN + PWR1,2,5,6,7_VIN = 1 V		0.41		
		Quiescent current per BUCK converter (in addition to I_{STD}), Cycle-skipping mode, VINA + PWR_VIN + PWR1,2,5,6,7_VIN = 5 V		0.46		
I_{Q_TOTAL}	Quiescent current (Total)	Typical Application: 6 A LED, Internal FETs, DMD. ACTIVE mode, all VIN pins combined, DMD, ILLUMINATION and PWR1,2 enabled, PWR3,4,5,6,7 disabled		38		mA
INTERNAL SUPPLIES						
V_{SUP_5P0V}	Internal supply, analog			5		V
V_{SUP_2P5V}	Internal supply, logic			2.5		V

7.5 Electrical Characteristics (continued)

over operating free-air temperature range. $V_{IN} = 12\text{ V}$, $T_A = 0\text{ to }+70^\circ\text{C}$, typical values are at $T_A = 25^\circ\text{C}$, configuration according to *Typical Applications* ($V_{IN} = 12\text{ V}$, $I_{OUT} = 6\text{ A}$, LED, internal FETs) (unless otherwise noted).

PARAMETER		TEST CONDITIONS	MIN	TYP	MAX	UNIT
DMD—LDO DMD						
V_{DRST_VIN}			6	12	20	V
V_{DRST_5P5V}				5.5		V
PGOOD	Power good DRST_5P5V	Rising		80%		
		Falling		60%		
OVP	Overvoltage protection DRST_5P5V			7.2		V
	Regulator dropout	At 25 mA, $V_{DRST_VIN} = 5.5\text{ V}$		56		mV
	Regulator current limit ⁽¹⁾		300	340	400	mA
DMD—REGULATOR						
$R_{DS(ON)}$	MOSFET ON-resistance	Switch A (from DRST_5P5V to DRST_HS_IND)		920		mΩ
		Switch B (from DRST_LS_IND to DRST_PGND)		450		
V_{FW}	Forward voltage drop	Switch C (from DRST_LS_IND to DRST_VBIAS ⁽¹⁾), $V_{DRST_LS_IND} = 2\text{ V}$, $I_F = 100\text{ mA}$		1.21		V
		Switch D (from DRST_LS_IND to DRST_VOFFSET ⁽¹⁾), $V_{DRST_LS_IND} = 2\text{ V}$, $I_F = 100\text{ mA}$		1.22		
t_{DIS}	Rail Discharge time	$C_{OUT} = 1\text{ }\mu\text{F}$			40	μs
t_{PG}	Power-good timeout	Not tested in production		15		ms
I_{LIMIT}	Switch current limit			610		mA
VOFFSET REGULATOR						
V_{OFFSET}	Output voltage			10		V
	DC output voltage accuracy	$I_{OUT} = 10\text{ mA}$	-0.3		0.3	V
	DC Load regulation	$I_{OUT} = 0\text{ mA to }10\text{ mA}$		-10		V/A
	DC Line regulation	$I_{OUT} = 10\text{ mA}$, $DRST_VIN = 8\text{ V to }20\text{ V}$		-5		mV/V
V_{RIPPLE}	Output ripple	$I_{OUT} = 10\text{ mA}$, $C_{OUT} = 1\text{ }\mu\text{F}$		200		mVpp
I_{OUT}	Output current		0.1		10	mA
PGOOD	Power-good threshold (fraction of nominal output voltage)	VOFFSET rising		86%		
		VOFFSET falling		66%		
C	Output capacitor	Recommended value ⁽⁴⁾ (use same value as output capacitor on VRESET)	1			μF
		$t_{DISCHARGE} < 40\text{ }\mu\text{s}$ at $V_{IN} = 8\text{ V}$			1	
VBIAS REGULATOR						
V_{BIAS}	Output voltage			18		V
	DC output voltage accuracy	$I_{OUT} = 10\text{ mA}$	-0.3		0.3	V
	DC Load regulation	$I_{OUT} = 0\text{ mA to }10\text{ mA}$		-18		V/A
	DC Line regulation	$I_{OUT} = 10\text{ mA}$, $DRST_VIN = 8\text{ V to }20\text{ V}$		-3		mV/V
V_{RIPPLE}	Output ripple	$I_{OUT} = 10\text{ mA}$, $C_{OUT} = 470\text{ nF}$		200		mVpp
I_{OUT}	Output current		0.1		10	mA
PGOOD	Power-good threshold (fraction of nominal output voltage)	VBIAS rising		86%		
		VBIAS falling		66%		

7.5 Electrical Characteristics (continued)

over operating free-air temperature range. $V_{IN} = 12\text{ V}$, $T_A = 0\text{ to }+70^\circ\text{C}$, typical values are at $T_A = 25^\circ\text{C}$, configuration according to *Typical Applications* ($V_{IN} = 12\text{ V}$, $I_{OUT} = 6\text{ A}$, LED, internal FETs) (unless otherwise noted).

PARAMETER		TEST CONDITIONS	MIN	TYP	MAX	UNIT
C	Output capacitor	Recommended value (use same or smaller value as output capacitors VOFFSET / VRESET)	470			nF
		$t_{DISCHARGE} < 40\ \mu\text{s}$ at $V_{IN} = 8\text{ V}$	470			
VRESET REGULATOR						
V_{RST}	Output voltage			-14		V
	DC output voltage accuracy	$I_{OUT} = 10\text{ mA}$	-0.3		0.3	V
	DC Load regulation	$I_{OUT} = 0\text{ mA to }10\text{ mA}$		-4		V/A
	DC Line regulation	$I_{OUT} = 10\text{ mA}$, $DRST_VIN = 8\text{ V to }20\text{ V}$		-2		mV/V
V_{RIPPLE}	Output ripple	$I_{OUT} = 10\text{ mA}$, $C_{OUT} = 1\ \mu\text{F}$		120		mVpp
I_{OUT}	Output current		0.1		10	mA
PGOOD	Power-good threshold			90%		
C	Output capacitor	Recommended value ⁽⁴⁾ (use same value as output capacitor on VOFFSET)	1			μF
		$t_{DISCHARGE} < 40\ \mu\text{s}$ at $V_{IN} = 8\text{ V}$	1			
DMD—BUCK CONVERTERS						
OUTPUT VOLTAGE						
$V_{PWR_1_VOUT}$	Output Voltage			1.1		V
$V_{PWR_2_VOUT}$	Output Voltage			1.8		V
	DC output voltage accuracy	$I_{OUT} = 0\text{ mA}$	-3%		3%	
MOSFET						
$R_{ON,H}$	High side switch resistance	25°C , $V_{PWR_1,2_Boost} - V_{PWR1,2_SWITCH} = 5.5\text{ V}$		150		m Ω
$R_{ON,L}$	Low side switch resistance ⁽¹⁾	25°C		85		m Ω
LOAD CURRENT						
	Allowed load current ⁽²⁾				3	A
I_{OCL}	Current limit ⁽¹⁾	$L_{OUT} = 3.3\ \mu\text{H}$	3.2	3.6	4.2	A
ON-TIME TIMER CONTROL						
t_{ON}	On time	$V_{IN} = 12\text{ V}$, $V_O = 5\text{ V}$		120		ns
$t_{OFF(MIN)}$	Minimum off time ⁽¹⁾	$T_A = 25^\circ\text{C}$, $V_{FB} = 0\text{ V}$		270		ns
START-UP						
	Soft start		1	2.5	4	ms
PGOOD						
Ratio _{OV}	Overvoltage protection			120%		
Ratio _{PG}	Relative power good level	Low to high		72%		
ILLUMINATION—LDO ILLUM						
V_{ILLUM_VIN}			6	12	20	V
V_{ILLUM_5P5V}				5.5		V
PGOOD	Power good ILLUM_5P5V	Rising		80%		
		Falling		60%		
OVP	Overvoltage protection ILLUM_5P5V			7.2		V
	Regulator dropout	At 25 mA, $V_{ILLUM_VIN} = 5.5\text{ V}$		53		mV
	Regulator current limit ⁽¹⁾		300	340	400	mA

7.5 Electrical Characteristics (continued)

over operating free-air temperature range. $V_{IN} = 12\text{ V}$, $T_A = 0\text{ to }+70^\circ\text{C}$, typical values are at $T_A = 25^\circ\text{C}$, configuration according to *Typical Applications* ($V_{IN} = 12\text{ V}$, $I_{OUT} = 6\text{ A}$, LED, internal FETs) (unless otherwise noted).

PARAMETER		TEST CONDITIONS	MIN	TYP	MAX	UNIT
ILLUMINATION—DRIVER A,B						
V_{ILLUM_A,B_IN}	Input supply voltage range		6	12	20	V
PWM						
f_{SW}	Oscillator frequency	$3\text{ V} < V_{IN} < 20\text{ V}$		600		kHz
t_{DEAD}	Output driver dead time	HDRV off to LDRV on, TRDLY = 0		28		ns
		HDRV off to LDRV on, TRDLY = 1		40		
		LDRV off to HDRV on, TRDLY = 0		35		
MAXIMUM CURRENTS						
HSD OC	High-side drive over current	Internal switches, I_{DS} threshold, single buck (6 A use case)		9.5		A
LSD MC	Low-side drive maximum allowed current	Both directions In or Out. Internal switches, I_{DS} threshold, single buck (6 A use case)		9.5		A
BOOT DIODE						
V_{DFWD}	Bootstrap diode forward voltage	$I_{BOOT} = 5\text{ mA}$		0.75		V
PGOOD						
RatioUV	Undervoltage protection			89%		
POWER FETs						
R_{ON}	Power FETs	High-Side, $T_A = 25^\circ\text{C}$, $V_{ILLUM_A,B_BOOST} - I_{ILLUM_A,B_SW} = 5.5\text{ V}$		150		m Ω
		Low-side, $T_A = 25^\circ\text{C}$		85		
LED CURRENT CONTROL						
V_{LED_ANODE}	LED anode voltage ⁽¹⁾	Ratio with respect to V_{ILLUM_A,B_VIN} (Duty cycle limitation)	0.85x			V
					7.2	
I_{LED}	LED currents	$V_{ILLUM_A,B_VIN} \geq 8\text{ V}$. See register SWx_IDAC[9:0] (Register Maps) for settings.	300		6000	mA
	DC current offset, CH1,2,3_SWITCH	$R_{LIM} = 25\text{ m}\Omega$	-75	0	75	mA
	Transient LED current limit range (programmable)	20% higher than I_{LED} . Min-setting, $R_{LIM} = 25\text{ m}\Omega$		0.67		A
		20% higher than I_{LED} . Max-setting, $R_{LIM} = 25\text{ m}\Omega$		8		
t_{RISE}	Current rise time	I_{LED} from 5% to 95%, $I_{LED} = 300\text{ mA}$, transient current limit disabled ⁽¹⁾			50	μs
BUCK CONVERTERS—LDO_BUCKS						
V_{PWR_VIN}	Input voltage range PWR1,2,5,6,7_VIN		6	12	20	V
V_{PWR_5P5V}	PWR_5P5V			5.5		V
PGOOD	Power good PWR_5P5V	Rising		80%		
		Falling		60%		
OVP	Overvoltage Protection PWR_5P5V			7.2		V
	Regulator dropout	At 25 mA, $V_{PWR_VIN} = 5.5\text{ V}$		41		mV
	Regulator current limit ⁽¹⁾		300	340	400	mA
BUCK CONVERTER—GENERAL PURPOSE BUCK CONVERTER ⁽⁷⁾						
OUTPUT VOLTAGE						

7.5 Electrical Characteristics (continued)

over operating free-air temperature range. $V_{IN} = 12\text{ V}$, $T_A = 0\text{ to }+70^\circ\text{C}$, typical values are at $T_A = 25^\circ\text{C}$, configuration according to *Typical Applications* ($V_{IN} = 12\text{ V}$, $I_{OUT} = 6\text{ A}$, LED, internal FETs) (unless otherwise noted).

PARAMETER		TEST CONDITIONS	MIN	TYP	MAX	UNIT
V_{PWR6_VOUT}	Output voltage (General purpose buck2)	8-bit programmable	1		5	V
	DC output voltage accuracy	$I_{OUT} = 0\text{ mA}$	-3.5%		3.5%	
MOSFET						
$R_{ON,H}$	High side switch resistance	25°C , $V_{PWR6_Boost} - V_{PWR6_SWITCH} = 5.5\text{ V}$		150		m Ω
$R_{ON,L}$	Low side switch resistance ⁽¹⁾	25°C		85		m Ω
LOAD CURRENT						
	Allowed load current PWR6 ⁽²⁾			2		A
I_{OCL}	Current limit ^{(1) (2)}	$L_{OUT} = 3.3\text{ }\mu\text{H}$	3.2	3.6	4.2	A
ON-TIME TIMER CONTROL						
t_{ON}	On time	$V_{IN} = 12\text{ V}$, $V_O = 5\text{ V}$		120		ns
$t_{OFF(MIN)}$	Minimum off time ⁽¹⁾	$T_A = 25^\circ\text{C}$, $V_{FB} = 0\text{ V}$		270	310	ns
START-UP						
	Soft start		1	2.5	4	ms
PGOOD						
Ratio _{OV}	Overvoltage protection			120%		
Ratio _{PG}	Relative power good level	Low to high		72%		
AUXILIARY LDOs						
$V_{PWR3,4_VIN}$	Input voltage range	LDO1 (PWR4), LDO2 (PWR3)	3.3	12	20	V
PGOOD	Power good PWR3,4_VOUT	PWR3,4_VOUT rising		80%		
		PWR3,4_VOUT falling		60%		
OVP	Overvoltage protection PWR3,4_VOUT			7		V
	DC output voltage accuracy PWR3,4_VOUT	$I_{OUT} = 0\text{ mA}$	-3%		3%	
	Regulator current limit ⁽¹⁾		300	340	400	mA
t_{ON}	Turn-on time	to 80% of $V_{OUT} = \text{PWR3 and PWR4}$, $C = 1\text{ }\mu\text{F}$		40		μs
LDO2 (PWR3)						
V_{PWR3_VOUT}	Output voltage PWR3_VOUT			2.5		V
	Load current capability			200		mA
	DC load regulation PWR3_VOUT	$V_{OUT} = 2.5\text{ V}$, $I_{OUT} = 5\text{ mA to }200\text{ mA}$		-70		mV/A
	DC line regulation PWR3_VOUT	$V_{OUT} = 2.5\text{ V}$, $I_{OUT} = 5\text{ mA}$, $PWR3_VIN = 3.3\text{ to }20\text{ V}$		30		$\mu\text{V/V}$
LDO1 (PWR4)						
V_{PWR4_VOUT}	Output voltage PWR4_VOUT			3.3		V
	Load current capability			200		mA
	DC load regulation PWR4_VOUT	$V_{OUT} = 3.3\text{ V}$, $I_{OUT} = 5\text{ mA to }200\text{ mA}$		-70		mV/A
	DC line regulation PWR4_VOUT	$V_{OUT} = 3.3\text{ V}$, $I_{OUT} = 5\text{ mA}$, $PWR4_VIN = 4\text{ to }20\text{ V}$		30		$\mu\text{V/V}$
	Regulator dropout	At 25 mA, $V_{OUT} = 3.3\text{ V}$, $V_{PWR4_VIN} = 3.3\text{ V}$		48		mV
MEASUREMENT SYSTEM						
LABB						

7.5 Electrical Characteristics (continued)

over operating free-air temperature range. $V_{IN} = 12\text{ V}$, $T_A = 0\text{ to }+70^\circ\text{C}$, typical values are at $T_A = 25^\circ\text{C}$, configuration according to *Typical Applications* ($V_{IN} = 12\text{ V}$, $I_{OUT} = 6\text{ A}$, LED, internal FETs) (unless otherwise noted).

PARAMETER		TEST CONDITIONS	MIN	TYP	MAX	UNIT
T _{RC}	Settling time	To 1% of final value ⁽¹⁾		4.6	6.6	μs
		To 0.1% of final value ⁽¹⁾		7	10	
V _{ACMPR_IN_LABB}	Input voltage range ACMPR_IN_LABB		0		1.5	V
	Sampling window ACMPR_IN_LABB	Programmable per 7 μs	7		28	μs
DIGITAL CONTROL - LOGIC LEVELS AND TIMING CHARACTERISTICS						
V _{SPI_VIN}	SPI supply voltage range	SPI_VIN	1.7		3.6	V
V _{OL}	Output low-level	RESET_Z, ACMPR_OUT, CLK_OUT. I _O = 0.3 mA sink current	0		0.3	V
		SPI_DOUT. I _O = 5 mA sink current	0		0.3 × V _{SPI_VIN}	
		INT_Z. I _O = 1.5 mA sink current	0		0.3 × V _{SPI_VIN}	
V _{OH}	Output high-level	RESET_Z, ACMPR_OUT, CLK_OUT. I _O = 0.3 mA source current	1.3		2.5	V
		SPI_DOUT. I _O = 5 mA source current	0.7 × V _{SPI_VIN}		V _{SPI_VIN}	
V _{IL}	Input low-level	PROJ_ON, CH_SEL_0, CH_SEL_1	0		0.4	V
		SPI_CSZ, SPI_CLK, SPI_DIN	0		0.3 × V _{SPI_VIN}	
V _{IH}	Input high-level	PROJ_ON, CH_SEL_0, CH_SEL_1	1.2			V
		SPI_CSZ, SPI_CLK, SPI_DIN	0.7 × V _{SPI_VIN}		V _{SPI_VIN}	
I _{BIAS}	Input bias current	V _{IO} = 3.3 V, any digital input pin			0.1	μA
SPI_CLK	SPI clock frequency ⁽³⁾	Normal SPI mode, DIG_SPI_FAST_SEL = 0, f _{OSC} = 9 MHz	0		36	MHz
		Fast SPI mode, DIG_SPI_FAST_SEL = 1, V _{SPI_VIN} > 2.3 V, f _{OSC} = 9 MHz	20		40	
t _{DEGLITCH}	Deglitch time	CH_SEL_0, CH_SEL_1 ⁽⁴⁾		300		ns
INTERNAL OSCILLATOR						
f _{OSC}	Oscillator frequency			9		MHz
	Frequency accuracy	T _A = 0 to 70°C	-5%		5%	
THERMAL SHUTDOWN						
T _{WARN}	Thermal warning (HOT threshold)			120		°C
	Hysteresis			10		
T _{SHTDWN}	Thermal shutdown (TSD threshold)			150		°C
	Hysteresis			15		

(1) Not production tested

(2) Take care to not exceed the max power dissipation. Refer to [Section 11.6](#).

(3) Maximum depends linearly on oscillator frequency f_{OSC}.

(4) Take care that the capacitor has the specified capacitance at the related voltage, that is, V_{OFFSET}, V_{BIAS}, or V_{RESET}.

(5) V_{IN} must be higher than the UVLO voltage setting, including after accounting for AC noise on V_{IN}, for the DLPA3000 to fully operate. While 6.0 V is the min V_{IN} voltage supported, TI recommends that the UVLO is never set below 6.21 V for fault fast power down. 6.21 V gives margin above 6.0 V to protect against the case where someone suddenly removes V_{IN}'s power supply, which causes the V_{IN} voltage to drop rapidly. Failure to keep V_{IN} above 6.0V before the mirrors are parked and VOFS, VRST, and VBIAS supplies are properly shut down can result in permanent damage to the DMD. Since 6.21 V is .21 V above 6.0 V, when UVLO trips there is time for the DLPA3000 and DLPC343x to park the DMD mirrors and do a fast shut down of supplies VOFS, VRST, and VBIAS. For

whatever UVLO setting is used, if VIN's power supply is suddenly removed enough bulk capacitance should be included on VIN inside the projector to keep VIN above 6.0 V for at least 100 μ s after UVLO trips.

- (6) UVLO should not be used for normal power down operation, it is meant as a protection from power loss.
- (7) General purpose buck2 (PWR6) is currently supported.

7.6 SPI Timing Parameters

SPI_VIN = 3.6 V, T_A = 0 to 70°C, C_L = 10 pF (unless otherwise noted).

PARAMETER		MIN	MAX	UNIT
f_{CLK}	Serial clock frequency	0	40	MHz
t_{CLKL}	Pulse width low, SPI_CLK, 50% level	10		ns
t_{CLKH}	Pulse width high, SPI_CLK, 50% level	10		ns
t_t	Transition time, 20% to 80% level, all signals	0.2	4	ns
t_{CSCR}	SPI_SS_Z falling to SPI_CLK rising, 50% level	8		ns
t_{CFCS}	SPI_CLK falling to SPI_CSZ rising, 50% level		1	ns
t_{CDS}	SPI_MOSI data setup time, 50% level	7		ns
t_{CDH}	SPI_MOSI data hold time, 50% level	6		ns
t_{iS}	SPI_MISO data setup time, 50% level	10		ns
t_{iH}	SPI_MISO data hold time, 50% level	0		ns
t_{CFDO}	SPI_CLK falling to SPI_MISO data valid, 50% level		13	ns
t_{CSZ}	SPI_CSZ rising to SPI_MISO HiZ		6	ns

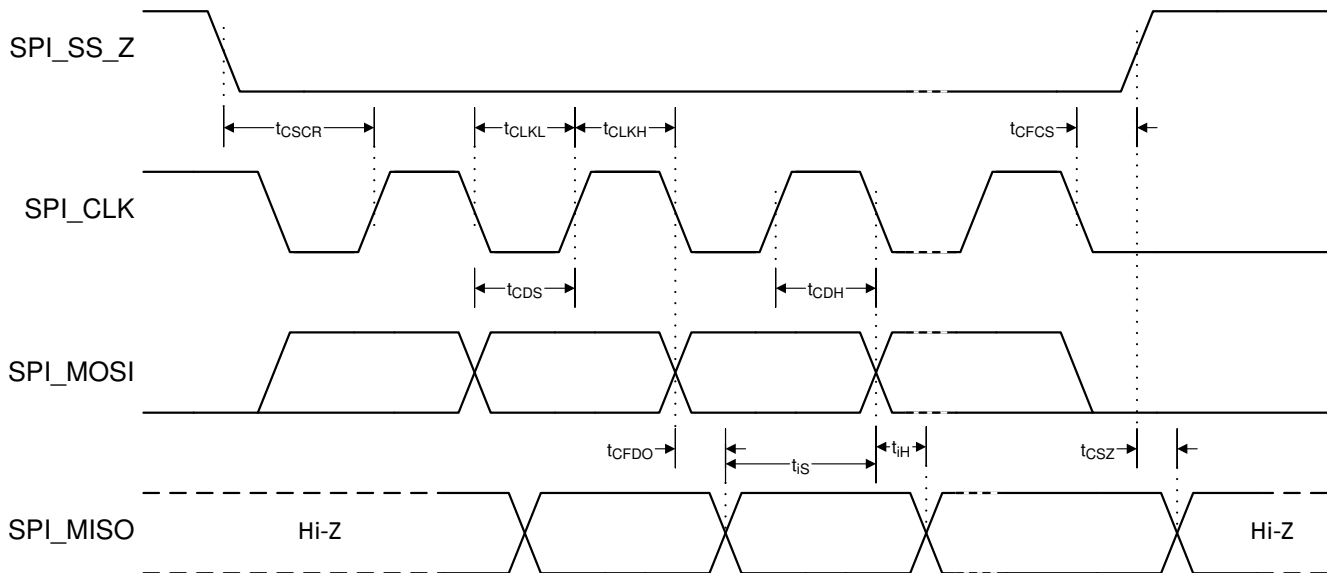

Figure 7-1. SPI Timing Diagram

8 Detailed Description

8.1 Overview

The DLPA3000 is a highly integrated power management IC optimized for DLP Pico Projector systems. It is targeting accessory applications up to several hundreds of lumen and is designed to support a wide variety of high-current LEDs. *Functional Block Diagram* shows a typical DLP Pico Projector implementation using the DLPA3000.

Part of the projector is the projector module which is an optimized combination of components consisting of for instance DLPA3000, LEDs, DMD, DLPC chip, memory and optional sensors/fan. The front-end chip controls the projector module. More information about the system and projector module configuration can be found in a separate application note.

Within the DLPA3000 several blocks can be distinguished. The blocks are listed below and subsequently discussed in detail:

1. Supply and monitoring: Creates internal supply and reference voltages and has functions such as thermal protection and low battery warning
2. Illumination: Block to control the light. Contains drivers, strobe decoder for the LEDs and power conversion
3. DMD: Generates voltages and their specific timing for the DMD. Contains regulators and DMD/DLPC buck converters
4. Buck converter: General purpose buck converter.
5. Auxiliary LDOs: Fixed voltage LDOs for customer usage
6. Measurement system: Analog front end to measure internal and external signals
7. Digital control: SPI, digital control

8.2 Functional Block Diagram

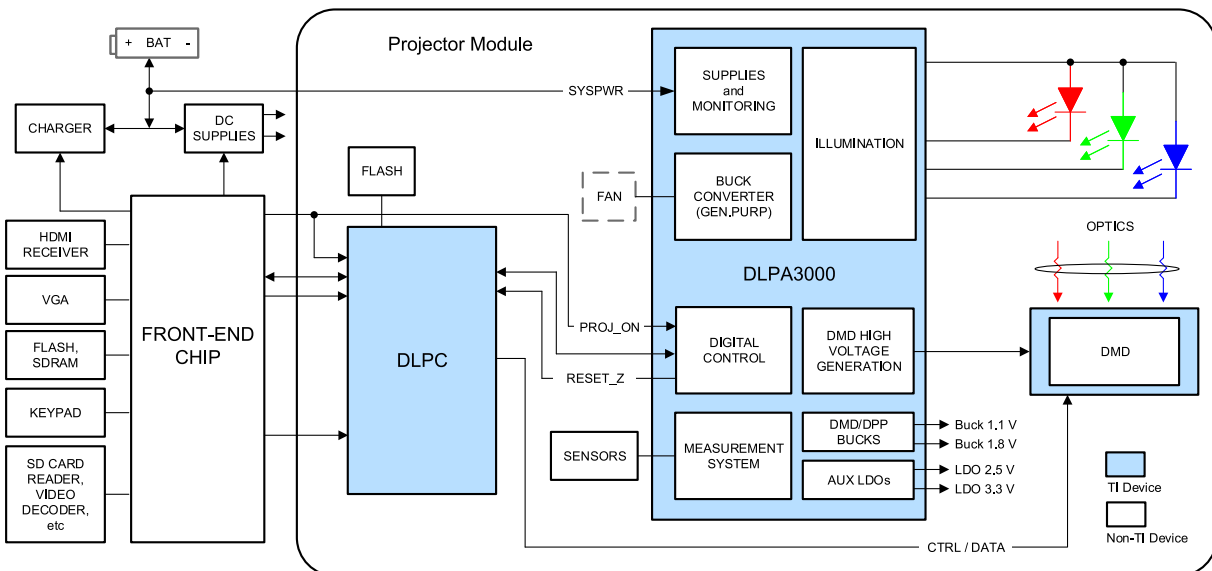

8.3 Feature Description

8.3.1 Supply and Monitoring

This block takes care of creating several internal supply voltages and monitors correct behavior of the device.

8.3.1.1 Supply

SYSPWR is the main supply of the DLPA3000. It can range from 6 V to 20 V, where the typical is 12 V. At power-up, several (internal) power supplies are started one after the other to make the system work correctly (Figure 8-1). A sequential startup provides that all the different blocks start in a certain order and prevent excessive startup currents. The main control to start the DLPA3000 is the control pin PROJ_ON. Once set high, the *basic* analog circuitry is started, which is needed to operate the digital and SPI interface. This circuitry

DLPA3000

DLPS052A – OCTOBER 2015 – REVISED SEPTEMBER 2023

is supplied by two LDO regulators that generate 2.5 V (SUP_2P5V) and 5 V (SUP_5P0V). These regulator voltages are for internal use only and not loaded by an external application. The output capacitors of those LDOs must be 2.2 μ F for the 2.5 V LDO and 4.7 μ F for the 5 V LDO, pin 91 and 92, respectively. Once these are up the digital core is started, and the DLPA3000 Digital State Machine (DSM) takes over.

Subsequently, the 5.5 V LDOs for various blocks are started: PWR_5V5V, DRST_5P5V and ILLUM_5P5V. Next, the buck converters and DMD LDOs are started (PWR_1 to PWR_4). The DLPA3000 is now awake and ready to be controlled by the DLPC (indicated by RESET_Z going high).

Lastly, the general purpose buck converters (PWR_6) can be started (if used) as well as the regulator that supplies the DMD. The DMD regulator generates the timing critical VOFFSET, VBIAS, and VRESET supplies.

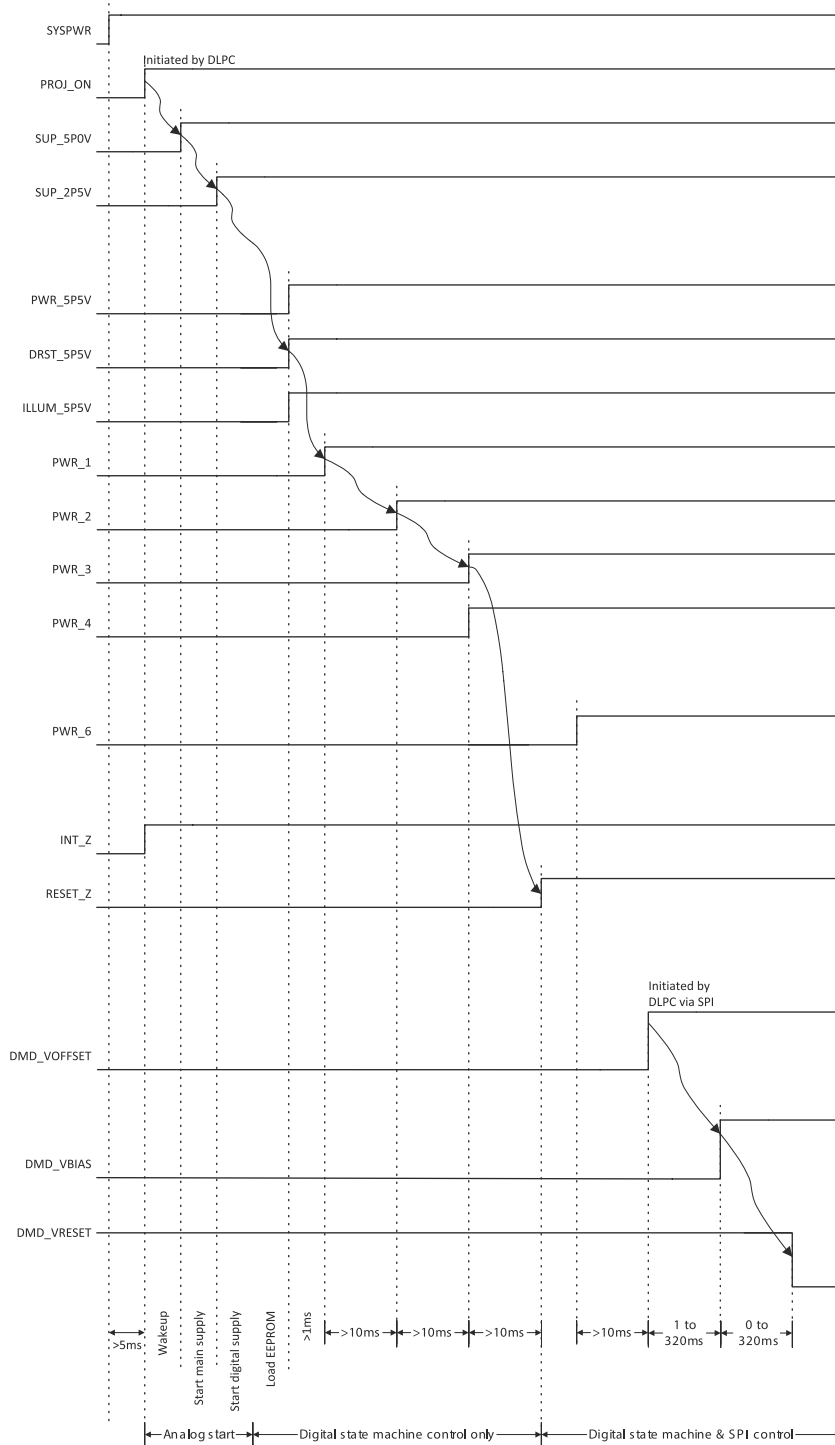

1. Arrows indicate sequence of events automatically controlled by digital state machine. Other events are initiated under SPI control.
2. SUP_5P0V and SUP_2P5V rise to a precharge level with SYSPWR, and reach the full level potential after PROJ_ON is pulled high.

Figure 8-1. Powerup Timing

8.3.1.2 Monitoring

Several possible faults are monitored by the DLPA3000. If a fault has occurred and the type of the fault can be read in the [Main Status register \(0x0C\)](#). Subsequently, an interrupt can be generated if a fault occurs. The fault conditions that generate an interrupt can be configured in the [Interrupt Mask register \(0x0D\)](#).

8.3.1.2.1 Block Faults

Fault conditions for several supplies (see [Table 8-5](#)) can be observed such as the low voltage supplies [SUPPLY_FAULT](#) (0x0C, bit 7). [ILLUM_FAULT](#) (0x0C, bit 6) monitors correct supply and voltage levels in the illumination block and [DMD_FAULT](#) (0x0C, bit 4) monitors a correct function of DMD block. The [PROJ_ON_INT](#) (0x0C, bit 5) indicates if PROJ_ON was asserted.

8.3.1.2.2 Low Battery and UVLO

The low battery warning register [BAT_LOW_WARN](#)(0x0C, bit 2) and battery low shutdown register [BAT_LOW_SHUT](#)(0x0C, bit 3) (see [Figure 8-2](#)) also monitor the battery voltage (input supply). They warn for a low V_{IN} supply voltage or automatically shut down the DLPA3000 when the V_{IN} supply drops below a predefined level, respectively. The threshold levels for these fault conditions have hysteresis. This hysteresis depends on the selected threshold voltage and is depicted in [Figure 8-3](#). It is recommended to set the low battery voltage higher than the undervoltage lock out such that a warning is generated before the device goes into shutdown.

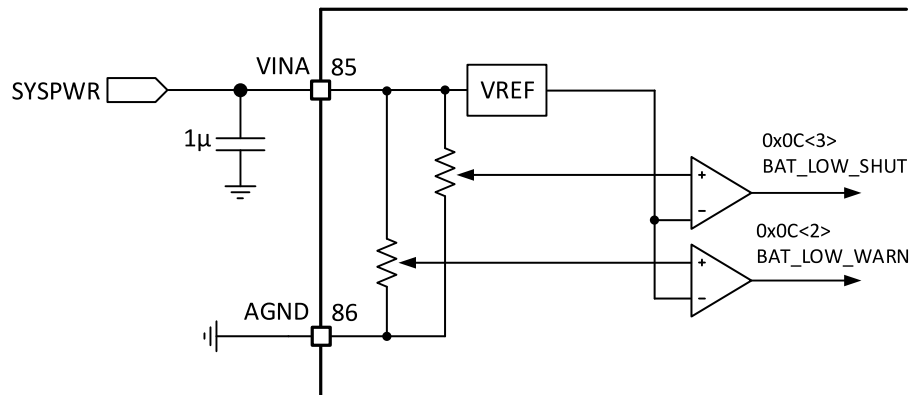

Figure 8-2. Battery Voltage Monitoring

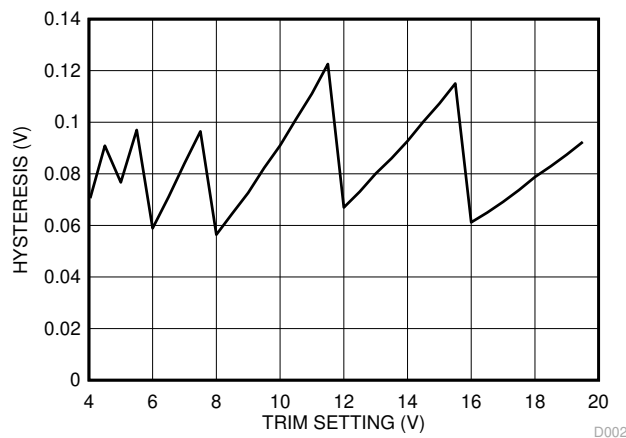

Figure 8-3. Hysteresis on V_{LOW_BAT} and V_{UVLO}

8.3.1.2.3 Auto LED Turn Off Functionality

The DLPA3000 can be supplied from either a battery pack or an adapter. The DLPA3000 uses several warning and detection levels to prevent system damage when the supply voltage drops below the predefined level or an interruption occurs.

For example, interruption of the supply voltage occurs when the adapter switches to another main outlet. If a battery pack is installed, the system power control should switch to the battery pack. A change of supply voltage from, for instance, 20 V to 8 V can occur, and thus the OVP level (which is ratio-metric; see [Ratio Metric Overvoltage Protection](#)) could become lower than V_{LED} . An OVP fault will be triggered and the system will switch off.

The `ILLUM_LED_AUTO_OFF_EN` (0x01, bit 2) function can be used to prevent the system from turning off in these circumstances. This function disables the LEDs when the supply voltage drops below LED auto off level. Keep the LED auto off level the same as the `BAT_LOW_WARN` (0x0C, bit 2) level. When the `ILLUM_LED_AUTO_OFF_EN` (0x01, bit 2) function is enabled, once a supply voltage drop is detected to below LED auto off level, the LEDs switch off and the system starts sending lower current levels to have a lower V_{LED} . After using lower currents, the LEDs can be switched on again by disabling the `ILLUM_LED_AUTO_OFF_EN` (0x01, bit 2) function. As a result, the system can continue working at the lower supply voltage using a lower intensity. The system monitors the `BAT_LOW_WARN` (0x0C, bit2) status, and once the main adapter is plugged in again (seen by `BAT_LOW_WARN` (0x0C, bit2) being low), the `ILLUM_LED_AUTO_OFF_EN` (0x01, bit 2) function can be enabled again. The LED currents can be restored to their original levels from before the supply voltage drop.

8.3.1.2.4 Thermal Protection

The chip temperature is constantly monitored to prevent overheating of the device. There are two levels of a fault condition. The first is `TS_WARN` (0x0C, bit 0) to warn for overheating. This is an indication that the chip temperature raises to a critical temperature. The next level of warning is `TS_SHUT` (0x0C, bit 1). This occurs at a higher temperature than `TS_WARN` (0x0C, bit 0) and shuts down the chip to prevent permanent damage. Both temperature faults have hysteresis on their levels to prevent rapid switching around the temperature threshold.

8.3.2 Illumination

The illumination function includes all blocks needed to generate light for the DLP system. To set the current through the LEDs accurately, use a control loop (Figure 8-4). The intended LED current is set through `IDAC[9:0]`. The Illumination driver controls the LED anode voltage V_{LED} and as a result a current flows through one of the LEDs. The LED current is measured from the voltage across sense resistor R_{LIM} . Based on the difference between the actual and intended current, the loop controls the output of the buck converter (V_{LED}) higher or lower. Which LED conducts the current is controlled by switches P, Q, and R. The *Openloop feedback circuitry* ensures that the control loop can be closed for cases when there is no path through the LED; for example, when $I_{LED} = 0$.

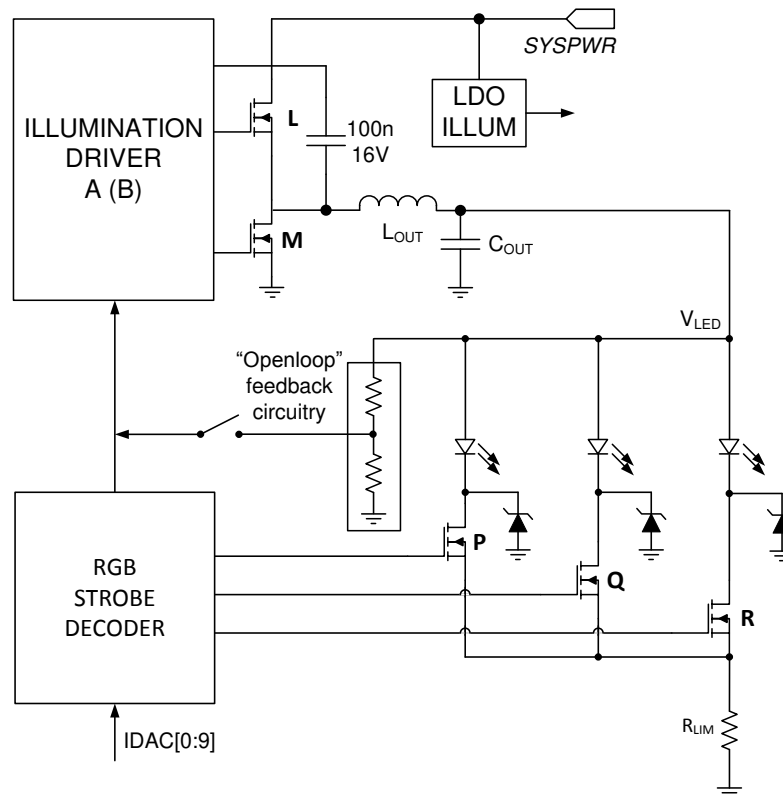

Figure 8-4. Illumination Control Loop

Within the illumination block, the following blocks can be distinguished:

- Programmable gain block
- LDO ILLUM: analog supply voltage for internal illumination blocks
- Illumination driver A: primary driver using internal FETs
- Illumination driver B: secondary driver – for future purpose; will not be discussed
- RGB stobe decoder: driver for external switches to control the on-off rhythm of the LEDs and measures the LED current

8.3.2.1 Programmable Gain Block

The current through the LEDs is determined by a digital number stored in the respective `SWx_IDAC(x)` registers (0x03 to 0x08). These registers determine the LED current which is measured through the sense resistor R_{LIM} . The voltage across R_{LIM} is compared with the current setting from the `SWx_IDAC(x)` registers (0x03 to 0x08) and the loop regulates the current to its set value.

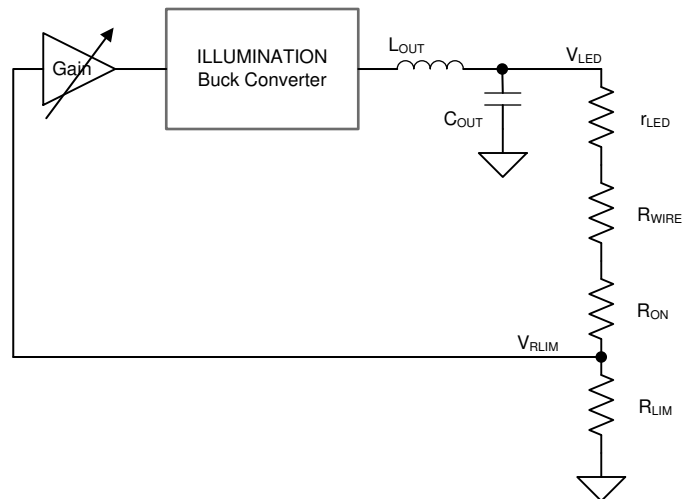

Figure 8-5. Programmable Gain Block in the Illumination Control Loop

When current is flowing through an LED, a forward voltage is built up over the LED. The LED also represents a (low) differential resistance, which is part of the load circuit for V_{LED} . Together with the wire resistance (R_{WIRE}) and the R_{ON} resistance of the FET switch, a voltage divider is created with R_{LIM} that is a factor in the loop gain of the ILED control. Under normal conditions, the loop is able to produce a well-regulated LED current of up to 6 A.

Since this voltage divider is part of the control loop, care must be taken while designing the system.

For instance, when two LEDs are connected in series, or when a relatively high wiring resistance is present in the loop, the loop gain will reduce due to the extra attenuation caused by the increased series resistances of $r_{LED} + R_{WIRE} + R_{ON}$. As a result, the loop response time is shortened. The loop gain is set to a default value which achieves good performance and no further adjustments are necessary.

As discussed previously, wiring resistance also impacts the control-loop performance. It is advisable to prevent unnecessary large-wire length in the loop. Keeping wiring resistance as low as possible is good for efficiency reasons. In case wiring resistance still impacts the response time of the loop, an appropriate setting of the gain block can be selected. The same goes for connector resistance and PCB tracks. Note that every milliohm (m Ω) counts. These precautions help to maintain the proper functioning of the I_{LED} current loop.

8.3.2.2 LDO Illum

This regulator is dedicated to the illumination block and provides an analog supply of 5.5 V to the internal circuitry. It is recommended to use a 1- μ F capacitor on the input and a 10- μ F capacitor on the output of the LDO.

8.3.2.3 Illumination Driver A

The illumination driver of the DLPA3000 is a buck converter with two internal low-ohmic N-channel FETs (see Figure 8-6). The theory of operation of a buck converter is explained in [Understanding Buck Power Stages in Switchmode Power Supplies](#). For proper operation, selection of the external components is very important, especially the inductor L_{OUT} and the output capacitor C_{OUT} . For best efficiency and ripple performance, an inductor and capacitor should be chosen with low equivalent series resistance (ESR). Set the voltage rating of the capacitor equal or greater than two times of the applied voltage across the capacitor in the application.

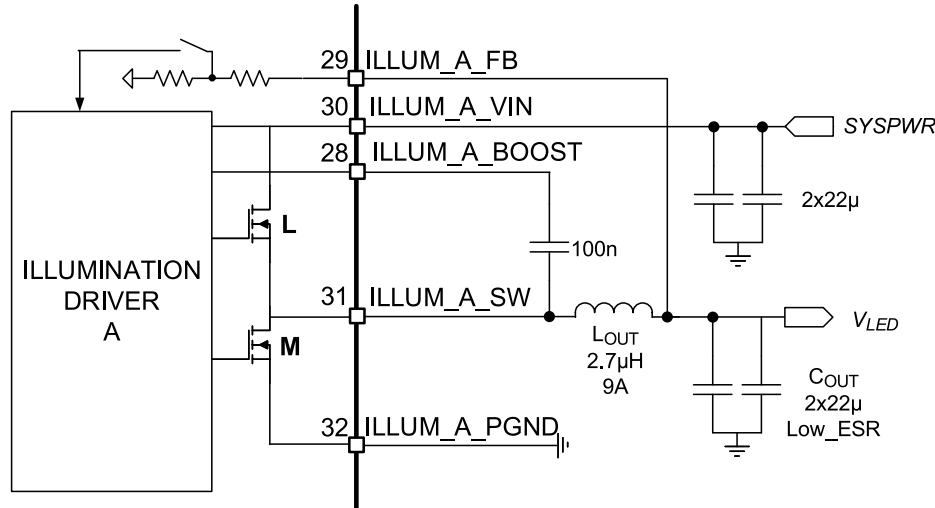

Figure 8-6. Typical Illumination Driver Configuration

Several factors determine the component selection of the buck converter, such as input voltage ($SYSPWR$), desired output voltage (V_{LED}) and the allowed output current ripple. Configuration starts with selecting the inductor L_{OUT} .

The value of the inductance of a buck power stage is selected such that the peak-to-peak ripple current flowing in the inductor stays within a certain range. Here, the target is set to have an inductor current ripple, k_{I_RIPPLE} , less than 0.3 (30%). The minimum inductor value can be calculated given the input and output voltage, output current, switching frequency of the buck converter ($f_{SWITCH} = 600$ kHz) and inductor ripple of 0.3 (30%):

$$L_{OUT} = \frac{V_{OUT} \cdot (V_{IN} - V_{OUT})}{k_{I_RIPPLE} \cdot I_{OUT} \cdot f_{SWITCH}} \quad (1)$$

Example: $V_{IN} = 12$ V, $V_{OUT} = 4.3$ V, $I_{OUT} = 6$ A results in an inductor value of $L_{OUT} = 2.7$ μ H

Once the inductor is selected, the output capacitor C_{OUT} can be determined. The value is calculated using the fact that the frequency compensation of the illumination loop has been designed for an LC-tank resonance frequency of 15 kHz:

$$f_{RES} = \frac{1}{2 \cdot \pi \cdot \sqrt{L_{OUT} \cdot C_{OUT}}} = 15\text{kHz} \quad (2)$$

Example: $C_{OUT} = 41.7$ μ F given that $L_{OUT} = 2.7$ μ H. A practical value is 2×22 μ F. Here a parallel connection of two capacitors is chosen to lower the ESR even further.

The selected inductor and capacitor determine the output voltage ripple. The resulting output voltage ripple V_{LED_RIPPLE} is a function of the inductor ripple k_{I_RIPPLE} , output current I_{OUT} , switching frequency f_{SWITCH} and the capacitor value C_{OUT} :

$$V_{LED_RIPPLE} = \frac{k_{I_RIPPLE} \cdot I_{OUT}}{8 \cdot f_{SWITCH} \cdot C_{OUT}} \quad (3)$$

Example: $k_{I_RIPPLE} = 0.3$, $I_{OUT} = 6$ A, $f_{SWITCH} = 600$ kHz and $C_{OUT} = 44$ μ F results in an output voltage ripple of $V_{LED_RIPPLE} = 8.5$ mVpp

As can be seen, this is a relative small ripple.

It is strongly advised to keep the capacitance value low. The larger the capacitor value the more energy is stored. In case of a V_{LED} going down, stored energy needs to be dissipated. This might result in a large discharge current. For a V_{LED} step down from V_1 to V_2 , while the LED current was I_1 . The theoretical peak reverse current is:

$$I_{2,MAX} = \sqrt{\frac{C_{OUT}}{L_{OUT}} \times (V_1^2 - V_2^2) + I_1^2} \quad (4)$$

For the single-LED case, it is advised to keep C_{OUT} at maximum 44 μ F.

Two other components need to be selected in the buck converter. The value of the input-capacitor (pin ILLUM_A_VIN) should be equal to or greater than the selected output capacitance C_{OUT} , in this case >44 μ F. The capacitor between ILLUM_A_SWITCH and ILLUM_A_BOOST is a charge pump capacitor to drive the high side FET. The recommended value is 100 nF.

8.3.2.4 RGB Strobe Decoder

The DLPA3000 contains circuitry to sequentially control the three color-LEDs (red, green and blue). This circuitry consists of three NMOS switches, the actual strobe decoder, and the LED current control (Figure 8-7). The NMOS switches are connected to the cathode terminals of the external LED package and turn on and off the currents through the LEDs.

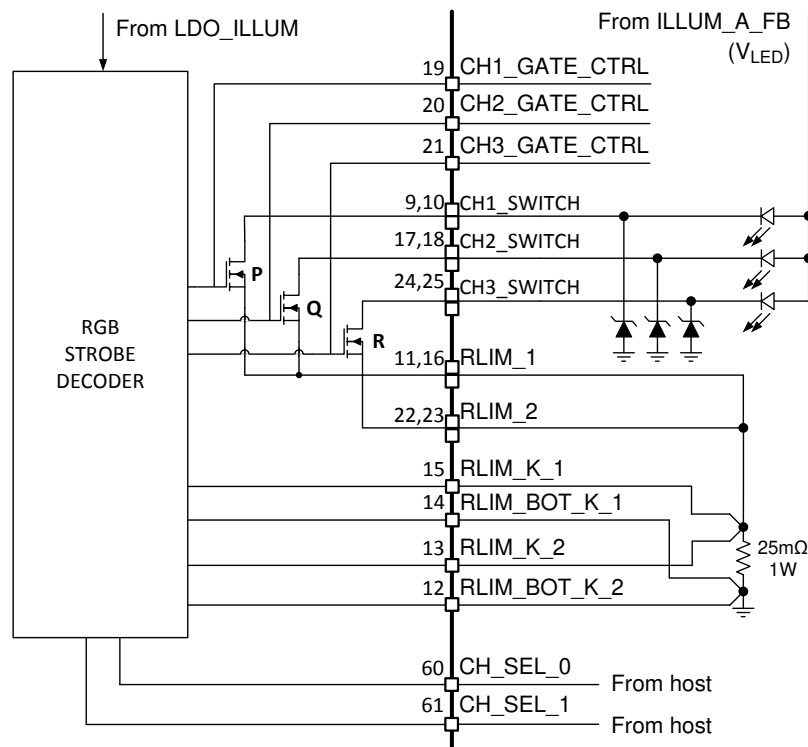

Figure 8-7. Switch Connection for a Common-Anode LED assembly

The NMOS FETs P, Q, and R are controlled by the CH_SEL_0 and CH_SEL_1 pins. CH_SEL[1:0] typically receive a rotating code switching from RED to GREEN to BLUE and then back to RED. The relation between CH_SEL[0:1] and which switch is closed is indicated in Table 8-1.

Table 8-1. Switch Positions for Common Anode RGB LEDs

PINS CH_SEL[1:0]	SWITCH			IDAC REGISTER
	P	Q	R	
00	Open	Open	Open	N/A
01	Closed	Open	Open	SW1_IDAC[9:0]
10	Open	Closed	Open	SW2_IDAC[9:0]
11	Open	Open	Closed	SW3_IDAC[9:0]

Besides enabling one of the switches, CH_SEL[1:0] also selects a 10-bit current setting for the control IDAC that is used as the set current for the LED. This set current together with the measured current through R_{LIM} is used to control the illumination driver to the appropriate V_{LED}. The current through the 3 LEDs can be set independently by registers SW1_IDAC to SW3_IDAC, 0x03 to 0x08 (Table 8-1).

Each current level can be set from off to 150mV/R_{LIM} in 1023 steps:

$$\text{Led current(A)} = 0 \text{ for bit value} = 0$$

$$\text{Led current(A)} = \frac{\text{Bit value} + 1}{1024} \cdot \frac{150\text{mV}}{R_{LIM}} \text{ for bit value} = 1 \text{ to } 1023 \quad (5)$$

The maximum current for R_{LIM}= 25 mΩ is thus 6 A.

8.3.2.4.1 Break Before Make (BBM)

The switching of the three LED NMOS switches (P, Q, and R) is controlled such that a switch is returned to the OPEN position first before the subsequent switch is set to the CLOSED position (BBM) (See Figure 8-8). There is delay time between opening and closing switches. Switches that already are in the CLOSED position and are to remain in the CLOSED state are not opened during the BBM delay time.

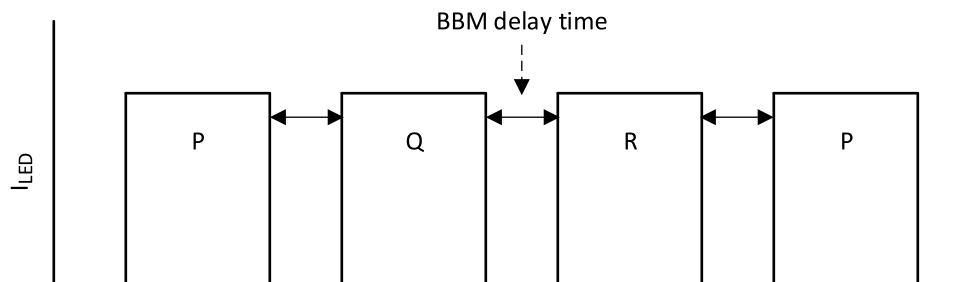

Figure 8-8. BBM Timing

8.3.2.4.2 Openloop Voltage

Several situations exist in which the control loop for the buck converter via the LED is not present. To prevent the output voltage of the buck converter to "run-away," the loop is closed by means of an internal resistive divider (see Figure 8-4—Openloop feedback circuitry). Situations in which the openloop voltage control is active:

- During the BBM period. Transitions from one LED to another implies that during the BBM time all LEDs are off.
- Current setting for all three LEDs is 0.

8.3.2.4.3 Transient Current Limit

Typically the forward voltages of the GREEN and BLUE diodes are close to each other (about 3 V to 5 V) however the forward voltage of the red diode is significantly lower (2 V to 4 V). This can lead to a current spike

in the RED diode when the strobe controller switches from green or blue to red. This happens because V_{LED} is initially at a higher voltage than required to drive the red diode. DLPA3000 provides transient current limiting for each switch to limit the current in the LEDs during the transition. The transient current limit value is controlled through register [ILLUM_ILIM](#) (0x02, bit [6:3]). In a typical application it is required only for the RED diode. The value for [ILLUM_ILIM](#) (0x02, bit [6:3]) should be set at least 20% higher than the DC regulation current. Register [ILLUM_SW_ILIM_EN](#) (0x02, bit [2:0]) contains three bits to select which switch employs the transient current limiting feature. The effect of the transient current limit on the LED current is shown in [Figure 8-9](#).

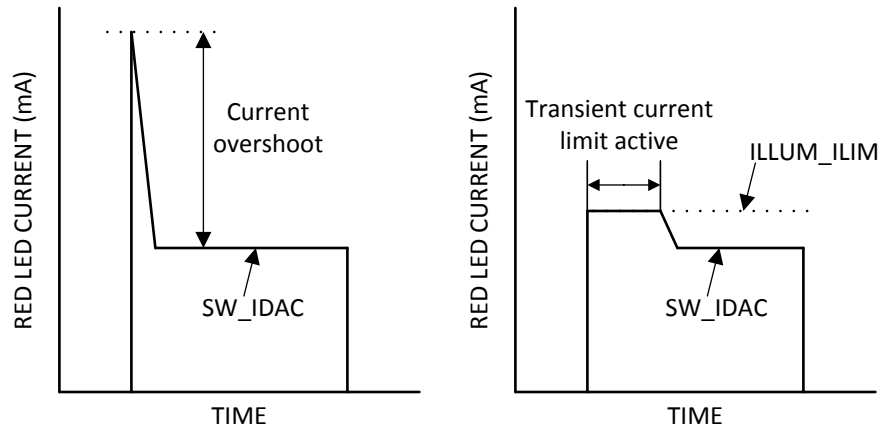

Figure 8-9. LED Current Without (Left) and With (Right) Transient Current Limit

8.3.2.5 Illumination Monitoring

The illumination block is continuously monitored for system failures to prevent damage to the DLPA3000 and LEDs. Several possible failures are monitored, such as a broken control loop and a too high or too low output voltage V_{LED} . The overall illumination fault bit is in [Main Status register \(0x0C\)](#) (ILLUM_FAULT). If any of the below failures occur, the ILLUM_FAULT bit may be set high:

- [ILLUM_BC1_PG_FAULT](#)
- [ILLUM_BC1_OV_FAULT](#)

Where PG is power good and OV is overvoltage.

8.3.2.5.1 Power Good

Both the Illumination drivers have a power good indication. The power good for the driver indicates if the output voltage (V_{LED}) is within a defined window indicating that the LED current has reached the set point. If the LED current cannot be controlled to the intended value, this fault occurs. Subsequently, bit ILLUM_BC1_PG_FAULT/ILLUM_BC2_PG_FAULT in the [Detailed status register1 \(0x27\)](#) is set high.

8.3.2.5.2 Ratio Metric Overvoltage Protection

The DLPA3000 illumination driver LED outputs are protected against open circuit use. In case no LED is connected and the DLPA3000 device is instructed to set the LED current to a specific level, the LED voltage (ILLUM_A_FB) will quickly rise and potentially rail to V_{IN} . This should be prevented. The OVP protection circuit triggers once V_{LED} crosses a predefined level. As a result the DLPA3000 is switched off.

The same protection circuit is triggered in case the supply voltage (V_{INA}) will become too low to have the DLPA3000 work properly given the V_{LED} level. This protection circuit is constructed around a comparator that will sense both the LED voltage and the V_{INA} supply voltage. The fraction of the V_{INA} is connected to the minus input of the comparator while the fraction of the V_{LED} voltage is connected to the plus input. Triggering occurs when the plus input rises above the minus input and an OVP fault is set. The fraction of the V_{INA} must be set between 1 V and 4 V to ensure proper operation of the comparator.

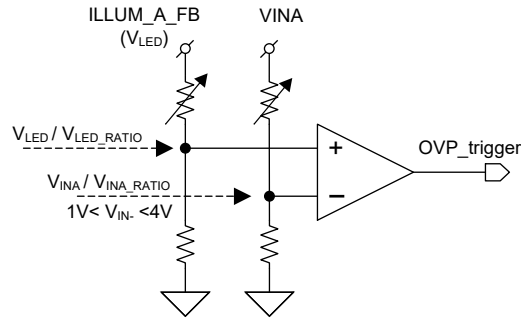

Figure 8-10. Ratio Metric OVP

In general an OVP fault is set when

$$V_{LED}/V_{LED_RATIO} \geq V_{INA}/V_{INA_RATIO}$$

thus when:

$$V_{LED} \geq V_{INA} \times V_{LED_RATIO}/V_{INA_RATIO}$$

8.3.2.6 Load Current and Supply Voltage

The DLPA3000 is designed to be able to deliver a current up to 6 Amps to a LED light source. This maximum current depends on the V_{LED} that is built up over the LED including all series resistances like R_{ON} , R_{WIRE} and R_{LIM} (see Figure 8-5). The Illum Buck Converter needs some headroom to work properly. This paragraph shows two typical situations for a fixed LED voltage and the accompanying supply voltage range for which a current of 4A or 6A can be delivered. Figure 8-11 shows the relation between the LED current and the supply voltage for a fixed LED voltage of 5 V, while Figure 8-12 shows this relation for a LED voltage of 6.3 V. While varying the Supply Voltage the curve shows a constant load current for a given LED voltage above the point where the control loop can maintain a constant current, but the load current drops below the point where the loop is no longer able to keep the current on its value set by the register. This knee-point shifts to higher supply voltage with rising temperature.

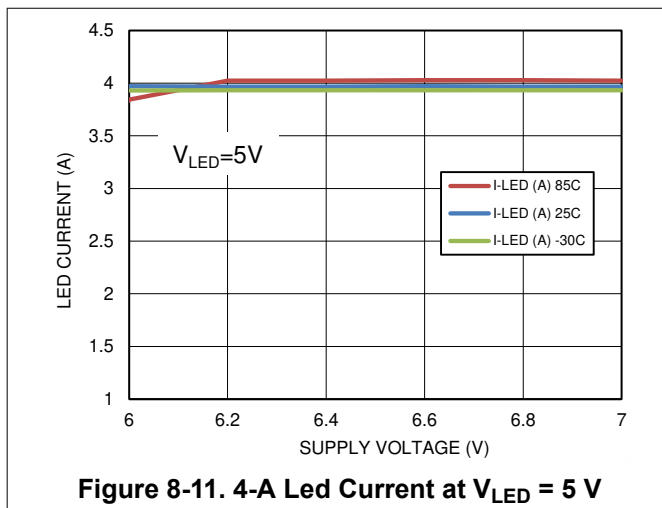

Figure 8-11. 4-A Led Current at $V_{LED} = 5\text{ V}$

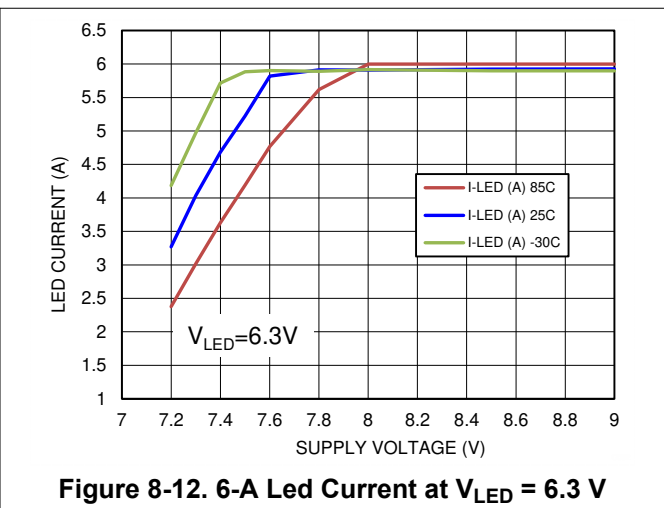
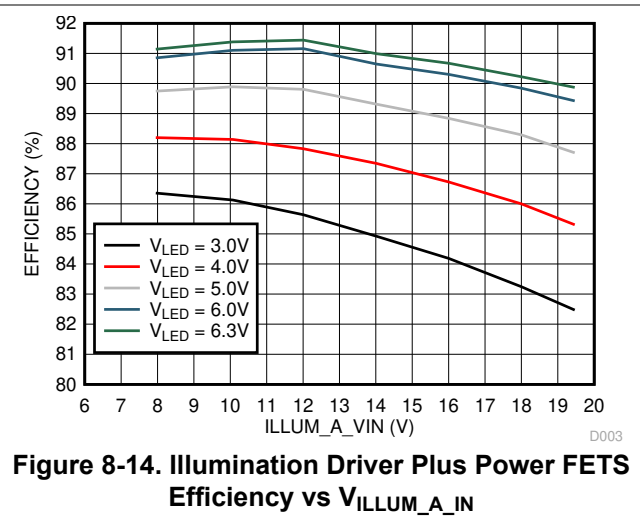
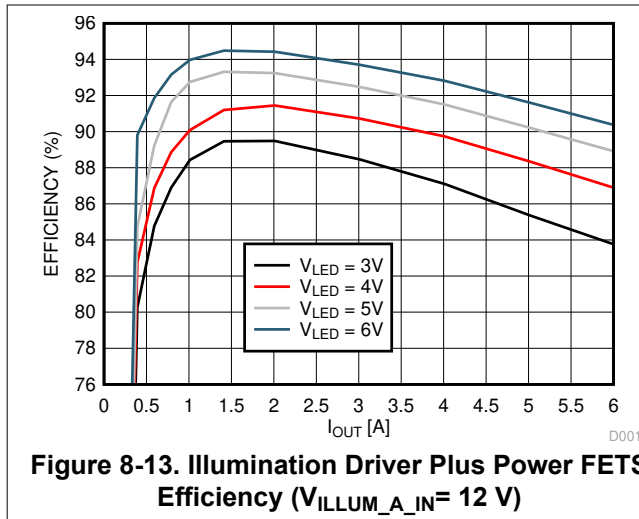

Figure 8-12. 6-A Led Current at $V_{LED} = 6.3\text{ V}$

8.3.2.7 Illumination Driver Plus Power FETS Efficiency

Figure 8-13 is an overview of the efficiency of the illumination driver plus power FETS for an input voltage of 12 V. The efficiency is shown for several output voltage levels (V_{LED}) where the load current is swept.

Figure 8-14 displays the efficiency versus input voltage ($V_{ILLUM_A_VIN}$) at various output voltage levels (V_{LED}).



8.3.3 DMD Supplies

This block contains all the supplies needed for the DMD and DLPC (see Figure 8-15). The block comprises:

- LDO_DMD: for internal supply
- DMD_HV: regulator generates high voltage supplies
- Two buck converters: for DLPC/DMD voltages

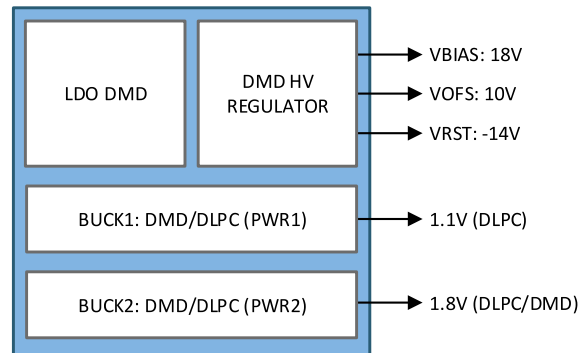

Figure 8-15. DMD Supplies Blocks

The DMD supplies block is designed to work with the DMD and the related DLPC. The DMD has its own set of supply voltage requirements. Besides the three high voltages, two supplies are needed for the DMD and the related DLPC (DLPC343x-family for instance). These supplies are made by two buck converters.

8.3.3.1 LDO DMD

This regulator is dedicated to the DMD supplies block and provides an analog supply voltage of 5.5 V to the internal circuitry. It is recommended to use a 1- μF capacitor in parallel with a 10- μF capacitor on the input and a 10- μF capacitor on the output of the LDO. Make the voltage rating of the capacitor equal or greater than two times of the applied voltage across the capacitor in the application.

8.3.3.2 DMD HV Regulator

The DMD HV regulator generates three high voltage supplies: DMD_VRESET, DMD_VBIAS and DMD_VOFFSET (see Figure 8-16). The DMD HV regulator uses a switching regulator (switch A-D), where the inductor is time shared between all three supplies. The inductor is charged up to a certain current value (current limit) and then discharged into one of the three supplies. If not all supplies need charging, the time available will be equally shared between those that do need charging. The recommended value for the capacitors is 1 μF for V_{RST} and V_{OFS} , and 470 nF for V_{BIAS} . The inductor value is 10 μH .

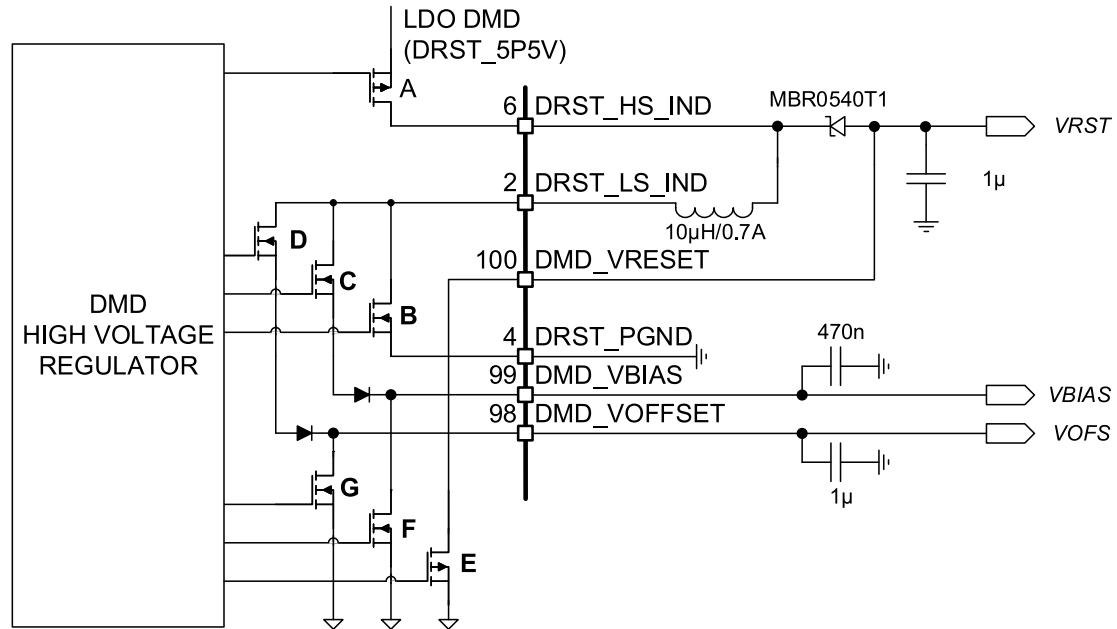

Figure 8-16. DMD High Voltage Regulator

8.3.3.2.1 Power-Up and Power-Down Timing

The power-up and power-down sequence is important to ensure a correct operation of the DLPA3000 and to prevent damage to the DMD. The DLPA3000 controls the correct sequencing of the DMD_VRESET, DMD_VBIAS and DMD_VOFFSET to ensure a reliable operation of the DMD.

The general startup sequence of the supplies was described previously in [Supply and Monitoring](#). The power-up sequence of the high-voltage DMD lines is especially important to prevent damaging the DMD. Damage could include, for example, that DMD mirrors get stuck or collide. A too-large delta voltage between DMD_VBIAS and DMD_VOFFSET could cause the damage and should therefore be prevented.

After PROJ_ON is pulled high, the DMD buck converters and LDOs are powered (PWR1-4) the DMD high voltage lines (HV) are sequentially enabled. First, DMD_VOFFSET is enabled. After a delay, DMD_VBIAS is enabled. Finally, after another delay, DMD_VRESET is enabled. The DLPA3000 is now fully powered and ready for starting projection.

For power down, there are two sequences: normal power down ([Figure 8-17](#)) and a fault fast power-down used in case a fault occurs ([Figure 8-18](#)).

In normal power-down mode, the power down is initiated after pulling PROJ_ON pin low. 25 ms after PROJ_ON is pulled low, DMD_VBIAS and DMD_VRESET will stop regulating. 10 ms later, DMD_VOFFSET will stop regulating. When DMD_VOFFSET stops regulating, RESET_Z is pulled low. 1 ms after the DMD_VOFFSET stops regulating, all other supplies are turned off. INT_Z remains high during the power-down sequence since no fault occurred. During power down, it is guaranteed that the HV levels do not violate the DMD specifications on these three lines. For this, it is important to select the capacitors such that $C_{V\text{OFFSET}} = C_{V\text{RESET}}$ and $C_{V\text{BIAS}} \leq C_{V\text{OFFSET}}$.

The fast power-down mode ([Figure 8-18](#)) is started in case a fault occurs (INT_Z will be pulled low), for instance due to overheating. The fast power-down mode can be enabled or disabled through register [FAST_SHUTDOWN_EN](#) (0x01, bit 7). The mode is enabled by default. After the fault occurs, regulation of DMD_VBIAS and DMD_VRESET is stopped. There is 540 µs default delay time between fault and stop of regulation. After the regulation stopped, there is 4 µs default delay time before all three DMD_VRESET, DMD_VBIAS and DMD_VOFFSET high voltages lines are discharged and RESET_Z is pulled low.

The DLPA3000 is now in a standby state. It remains in standby state until the fault resolves. In case the fault resolves, a restart is initiated. It starts then by powering up PWR_3 and follows the regular power up as depicted

in Figure 8-18. For proper discharge timing and levels, the capacitors such that $C_{V\text{OFFSET}}$ is equal to $C_{V\text{RESET}}$ and $C_{V\text{BIAS}}$ is $\leq C_{V\text{OFFSET}}$, $C_{V\text{RESET}}$.

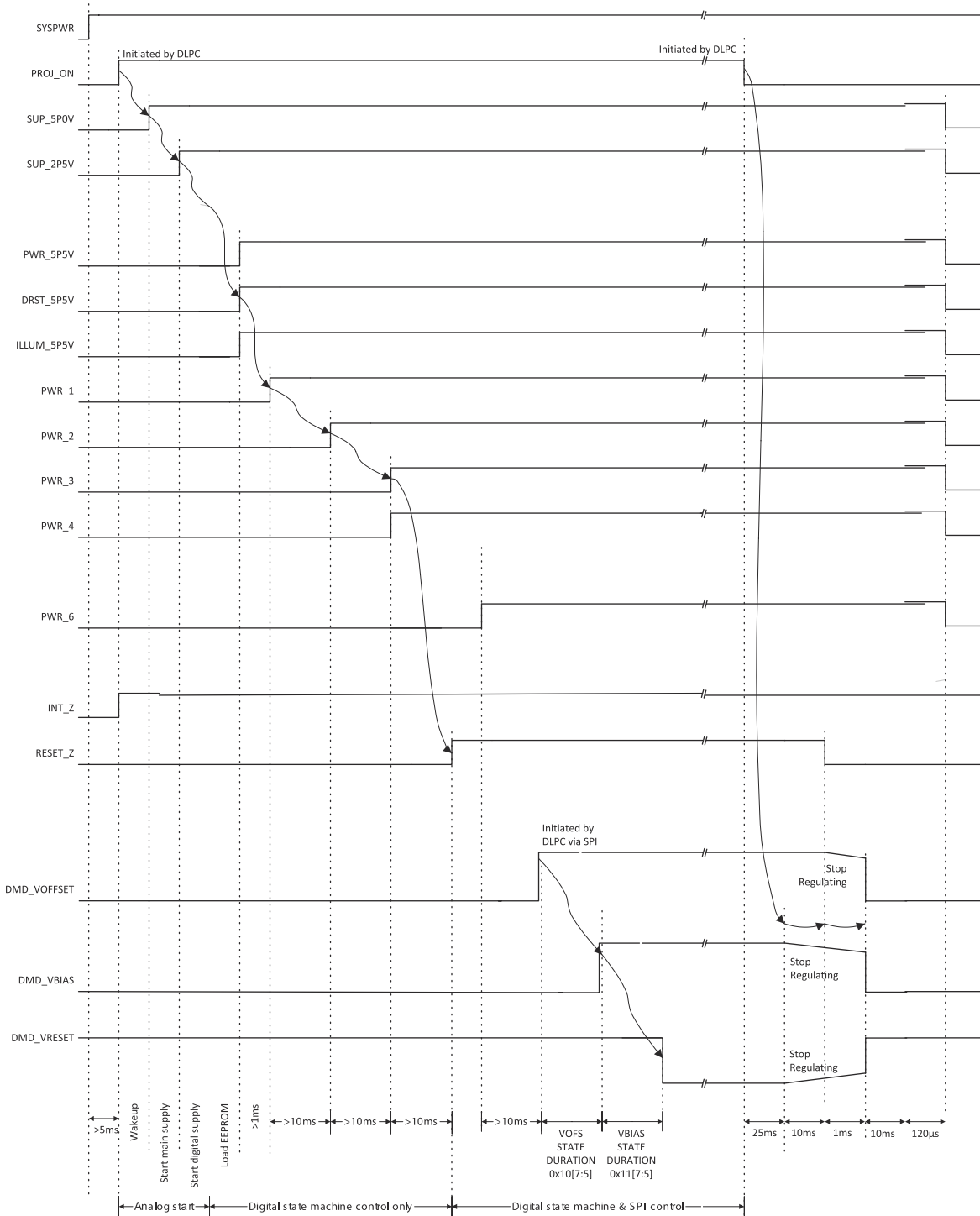

1. Arrows indicate sequence of events automatically controlled by digital state machine. Other events are initiated under SPI control.
2. SUP_5POV and SUP_2P5V rise to a precharge level with SYS_PWR, and reach the full level potential after PROJ_ON is pulled high.

Figure 8-17. Power Sequence Normal Shutdown Mode

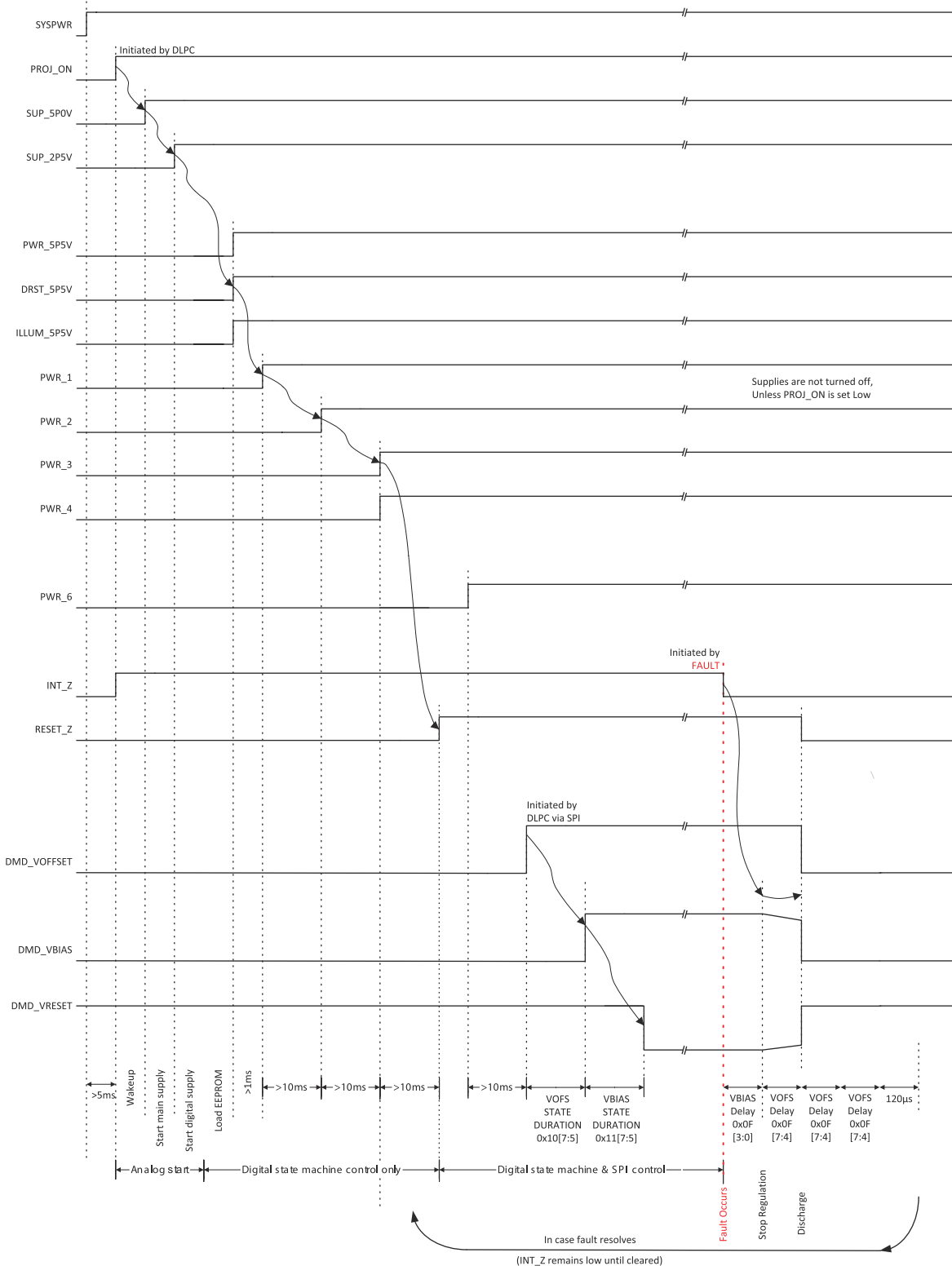

- Arrows indicate sequence of events automatically controlled by digital state machine. Other events are initiated under SPI control.
- SUP_5P0V and SUP_2P5V rise to a precharge level with SYS_PWR, and reach the full level potential after PROJ_ON is pulled high.

Figure 8-18. Power Sequence Fault Fast Shutdown Mode

8.3.3.3 DMD/DLPC Buck Converters

Each of the two DMD buck converters creates a supply voltage for the DMD and/or the DLPC. The values of the voltages for the DMD and DLPC used, for instance:

- DMD+DLPC3438: 1.1 V (DLPC) and 1.8 V (DLPC/DMD)

The topology of the buck converters is the same as the general purpose buck converters discussed later in this document. To configure the inductor and capacitor, see [Buck Converters](#).

A typical configuration is 3.3 μH for the inductor and $2 \times 22 \mu\text{F}$ for the output capacitor. The voltage rating of the capacitor is recommended to be equal or greater than two times of the applied voltage across the capacitor in the application.

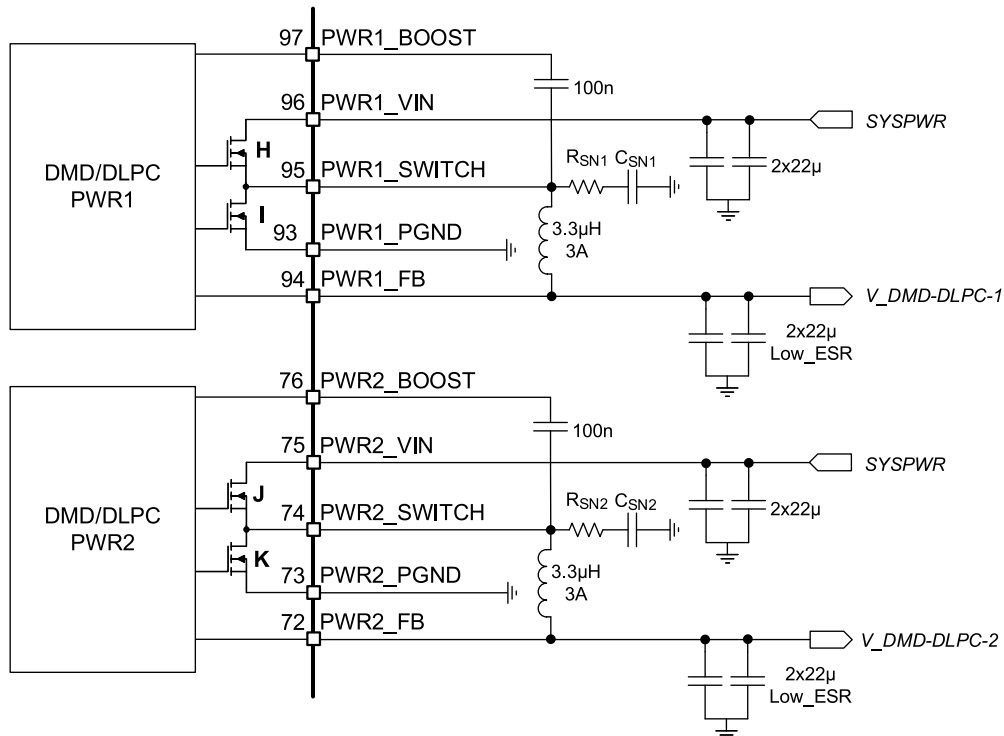

Figure 8-19. DMD/DLPC Buck Converters

8.3.3.4 DMD Monitoring

The DMD block is continuously monitored for failures to prevent damage to the DLPA3000 and/or the DMD. Several possible failures are monitored such that the DMD voltages can be guaranteed. Failures could be, for instance, a broken control loop or a too-high or too-low converter output voltage. The overall DMD fault bit is in [Main Status register \(0x0C\)](#) , DMD_FAULT. If any of the failures in [Table 8-2](#) occur, the DMD_FAULT bit will be set high.

Table 8-2. DMD FAULT Indication

POWER GOOD		
BLOCK	REGISTER BIT	THRESHOLD
HV Regulator	DMD_PG_FAULT	DMD_VRESET: 90%, DMD_VOFFSET and DMD_VBIAS: 86% rising, 66% falling
PWR1	BUCK_DMD1_PG_FAULT	Ratio: 72%
PWR2	BUCK_DMD2_PG_FAULT	Ratio: 72%
PWR3 (LDO_2)	LDO_GP2_PG_FAULT / LDO_DMD1_PG_FAULT	80% rising, 60% falling
PWR4 (LDO_1)	LDO_GP1_PG_FAULT / LDO_DMD1_PG_FAULT	80% rising, 60% falling
OVERVOLTAGE		
BLOCK	REGISTER BIT	THRESHOLD (V)
PWR1	BUCK_DMD1_OV_FAULT	Ratio: 120%
PWR2	BUCK_DMD2_OV_FAULT	Ratio: 120%
PWR3 (LDO_2)	LDO_GP2_OV_FAULT / LDO_DMD1_OV_FAULT	7
PWR4 (LDO_1)	LDO_GP1_OV_FAULT / LDO_DMD1_OV_FAULT	7

8.3.3.4.1 Power Good

The DMD HV regulator, DMD buck converters, auxiliary LDOS and the LDO DMD that supports the HV regulator have a power good indication.

The DMD HV regulator is continuously monitored to check if the output rails DMD_VRESET, DMD_VOFFSET and DMD_VBIAS are in regulation. If either one of the output rails drops out of regulation (for example, due to a shorted output or overloading), the DMD_PG_FAULT bit in [Detailed Status Register3 \(0x29\)](#) is set. The threshold for DMD_VRESET is 90% and the thresholds for DMD_VOFFSET and DMD_VBIAS are 86% (rising edge) and 66% (falling edge).

The power good signal for the two DMD buck converters indicate if their output voltage (PWR1_FB and PWR2_FB) are within a defined window. The relative power good ratio is 72%. This means that if the output voltage is below 72% of the set output voltage, the power good bit is asserted. The power good bits are in [Detailed Status Register3 \(0x29\)](#), bits BUCK_DMD1_PG_FAULT and BUCK_DMD2_PG_FAULT.

LDO_1 and LDO_2 output voltages are also monitored. When the power good fault of the LDO is asserted, it implies that the LDO voltage is below 80% (rising edge) or 60% (falling edge) of its intended value. The power good indication for the LDOs is in [Detailed Status Register3 \(0x29\)](#) , bits LDO_GP1_PG_FAULT / LDO_DMD1_PG_FAULT and LDO_GP2_PG_FAULT / LDO_DMD2_PG_FAULT.

8.3.3.4.2 Overvoltage Fault

An overvoltage fault occurs when an output voltage rises above a predefined threshold. Overvoltage faults are indicated for the DMD buck converters, auxiliary LDOS and the LDO DMD supporting the DMD HV regulator. The overvoltage fault of LDO_1 and LDO_2 are not incorporated in the overall DMD_FAULT when the LDOs are used as general purpose LDOs. [Table 8-2](#) provides an overview of the possible DMD overvoltage faults and their threshold levels.

8.3.4 Buck Converters

The DLPA3000 contains one general purpose buck converter and a supporting LDO (LDO_BUCKS). The programmable 8-bit buck converter can generate a voltage between 1 V and 5 V and have an output current limit of 3 A. General purpose buck2 (PWR6) is currently supported. One buck converter and the LDO_BUCKS is depicted in [Figure 8-20](#).

The two DMD/DLPC buck converters discussed earlier in the DMD section have the same architecture as these three buck converters and can be configured in the same way.

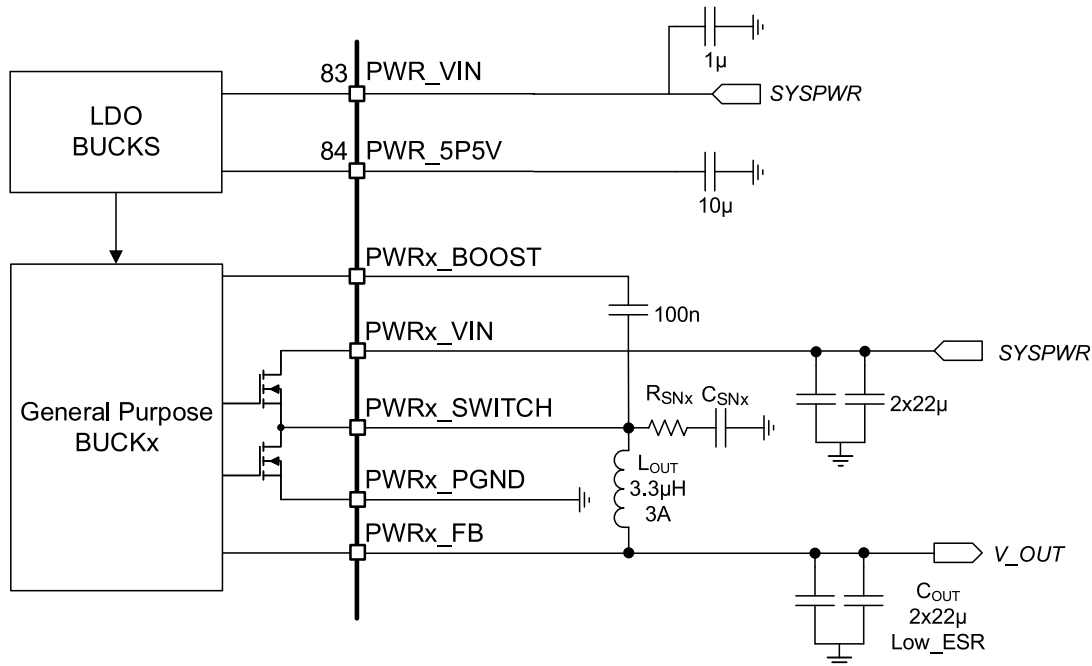

Figure 8-20. Buck Converter

8.3.4.1 LDO Bucks

This regulator supports the general purpose buck converter and the two DMD/DLPC buck converters and provides an analog voltage of 5.5 V to the internal circuitry. Use a 1 μF capacitor on the input and a 10 μF capacitor on the output of the LDO.

8.3.4.2 General Purpose Buck Converters

The buck converter is for general purpose use ([Figure 8-20](#)). The converter can be enabled or disabled through the [Enable Register \(0x01\): BUCK_GP2_EN](#).

General purpose buck2 (PWR6) has a current capability of 2 A.

The buck converter can operate in two switching modes: normal (600-kHz switching frequency) mode and the skip mode. The skip mode is designed to increase light load efficiency. As the output current decreases from heavy load condition, the inductor current is also reduced and eventually comes to point that its rippled valley touches zero level, which is the boundary between continuous conduction and discontinuous conduction modes. The rectifying MOSFET is turned off when its zero inductor current is detected. As the load current further decreases, the converter runs into discontinuous conduction mode. The on-time is kept almost the same as it was in the continuous conduction mode so that it takes longer time to discharge the output capacitor with smaller load current to the level of the reference voltage.

The theory of operation of a buck converter is explained in [Understanding Buck Power Stages in Switchmode Power Supplies](#). This section will therefore be limited to the component selection. For proper operation, selection of the external components is very important, especially the inductor L_{OUT} and the output capacitor C_{OUT} . For

best efficiency and ripple performance, an inductor and capacitor should be chosen with low equivalent series resistance (ESR).

The component selection of the buck converter is mainly determined by the output voltage. [Table 8-3](#) shows the recommended value for inductor L_{OUT} and capacitor C_{OUT} for a given output voltage.

Table 8-3. Recommended Buck Converter L_{OUT} and C_{OUT}

V_{OUT} (V)	L_{OUT} (μ H)			C_{OUT} (μ F)	
	MIN	TYP	MAX	MIN	MAX
1 – 1.5	1.0	2.2	4.7	10	132
1.5 – 3.3	2.2	3.3	4.7	22	68
3.3 – 5	3.3		4.7	22	68

The inductor peak-to-peak ripple current, peak current, and RMS current can be calculated using [Equation 6](#), [Equation 7](#), and [Equation 8](#), respectively. The inductor saturation current rating must be greater than the calculated peak current. Likewise, the RMS or heating current rating of the inductor must be greater than the calculated RMS current. The switching frequency of the buck converter is approximately 600 kHz (f_{SWITCH}).

$$I_{L_OUT_RIPPLE_P-P} = \frac{V_{OUT}}{V_{IN_MAX}} \cdot (V_{IN_MAX} - V_{OUT})$$

$$L_{OUT} \cdot f_{SWITCH} \tag{6}$$

$$I_{L_OUT_PEAK} = I_{L_OUT} + \frac{I_{L_OUT_RIPPLE_P-P}}{2} \tag{7}$$

$$I_{L_OUT(RMS)} = \sqrt{I_{L_OUT}^2 + \frac{1}{12} \cdot I_{L_OUT_RIPPLE_P-P}^2} \tag{8}$$

The capacitor value and ESR determines the level of output voltage ripple. The buck converter is intended for use with ceramic or other low ESR capacitors. Recommended values range from 22 μ F to 68 μ F. [Equation 9](#) can be used to determine the required RMS current rating for the output capacitor.

$$I_{C_OUT(RMS)} = \frac{V_{OUT} \cdot (V_{IN} - V_{OUT})}{\sqrt{12} \cdot V_{IN} \cdot L_{OUT} \cdot f_{SWITCH}} \tag{9}$$

Two other components need to be selected in the buck converter configuration. The value of the input-capacitor (pin PWRx_VIN) should be equal or greater than half the selected output capacitance C_{OUT} . In this case C_{IN} $2 \times 10 \mu$ F is sufficient. The capacitor between PWRx_SWITCH and PWRx_BOOST is a charge pump capacitor to drive the high side FET. The recommended value is 100 nF.

Since the switching edges of the buck converter are relatively fast, voltage overshoot and ringing can become a problem. To overcome this problem a snubber network is used. The snubber circuit consists of a resistor and capacitor that are connected in series from the switch node to ground. The snubber circuit is used to damp the parasitic inductances and capacitances during the switching transitions. This circuit reduces the ringing voltage and also reduces the number of ringing cycles. The snubber network is formed by RSNx and CSNx. More information on controlling switch-node ringing in synchronous buck converters and configuring the snubber can be found in [Analog Application Journal 2Q 2012](#).

8.3.4.3 Buck Converter Monitoring

The buck converter block is continuously monitored for system failures to prevent damage to the DLPA3000 and peripherals. Several possible failures are monitored such as a too-high or too-low output voltage. The possible faults are summarized in [Table 8-4](#).

Table 8-4. Buck Converter Fault Indication

POWER GOOD		
BLOCK	REGISTER BIT	THRESHOLD (RISING EDGE)
Gen.Buck2 (PWR6)	BUCK_GP2_PG_FAULT	Ratio 72%
OVERVOLTAGE		
Gen.Buck2 (PWR6)	BUCK_GP2_OV_FAULT	Ratio 120%

8.3.4.3.1 Power Good

The buck converter as well as the supporting LDO_BUCK have a power good indication. The buck converter has a separate indication.

The power good for the buck converter indicates if their output voltage (PWR6_FB) is within a defined window. The relative power good ratio is 72%. This means that if the output voltage is below 72% of the set voltage the PG_fault bit is set high. The power good bit of the buck converter is in the [Detailed Status Register1 \(0x27\)](#) bit:

- BUCK_GP2_PG_FAULT for BUCK2 (PWR6)

8.3.4.3.2 Overvoltage Fault

An overvoltage fault occurs when an output voltage rises above a predefined threshold. Overvoltage faults are indicated for the buck converters, and LDO_BUCKS. The overvoltage fault of the LDO_BUCKS is asserted if the LDO voltage is above 7.2 V. The overvoltage of the general purpose buck converter is 120% of the set value (the default value is 1 V) and can be read through register [Detailed status register2 \(0x28\)](#) BUCK_GP2_OV_FAULT.

8.3.4.4 Buck Converter Efficiency

An overview of the efficiency of the buck converter for an input voltage of 12 V is provided in [Figure 8-21](#). The efficiency is shown for several output voltage levels where the load current is swept.

[Figure 8-22](#) depicts the buck converter efficiency versus input voltage (V_{IN}) for a load current (I_{OUT}) of 1 A for various output voltage levels (V_{OUT}).

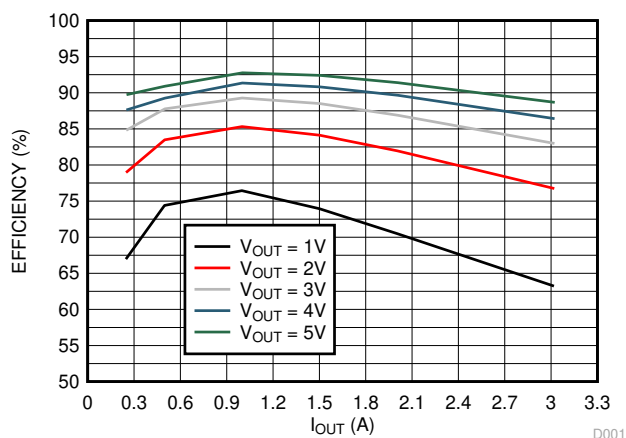

Figure 8-21. Buck Converter Efficiency vs I_{OUT} ($V_{IN} = 12 V$)

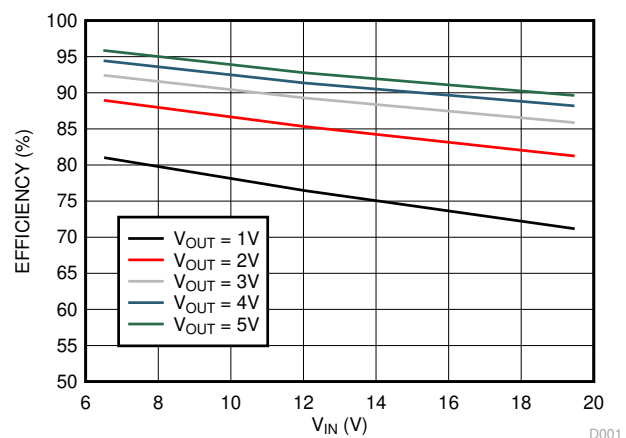

Figure 8-22. Buck Converter Efficiency vs V_{IN} ($I_{OUT} = 1 A$)

8.3.5 Auxiliary LDOs

An additional external application can use two auxiliary LDOs: LDO_1 and LDO_2. All other LDOs are for internal use only and should not be loaded. LDO_1 (PWR4) is a fixed voltage of 3.3 V, while LDO_2 (PWR3) is a fixed voltage of 2.5 V. Both LDOs are capable to deliver 200 mA.

8.3.6 Measurement System

The measurement system (Figure 8-23) is designed to sense internal and external nodes and convert them to digital by the implemented AFE comparator. The reference signal for this comparator, ACMPR_REF, is a low pass filtered PWM signal coming from the DLPC. To be able to cover a wide range of input signals, a variable gain amplifier (VGA) is added with three gain settings (1x, 9.5x, and 18x). The maximum input voltage of the VGA is 1.5 V. However, some of the internal voltages are too large to be handled by the VGA and are divided down first.

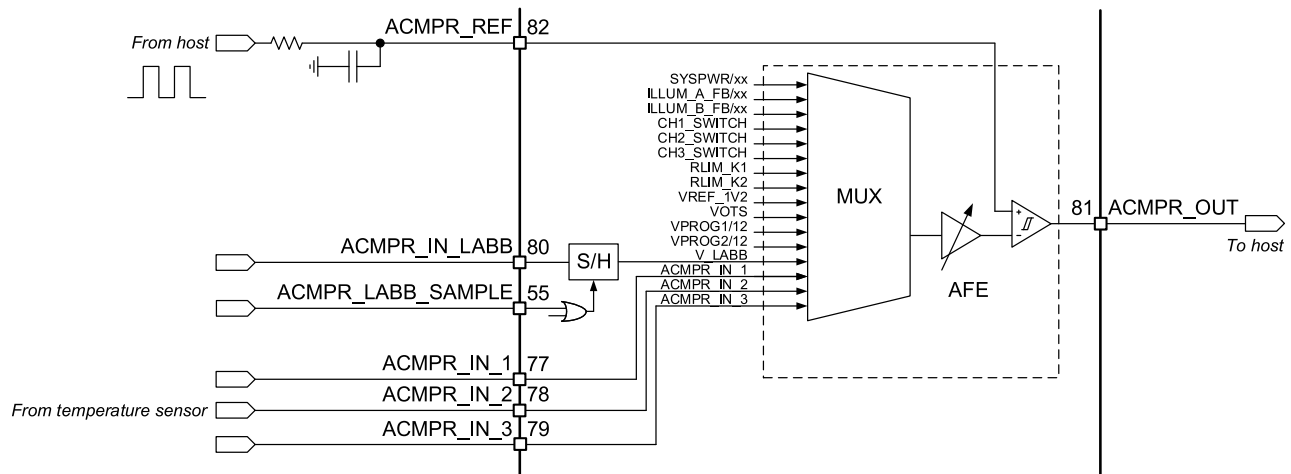

Figure 8-23. Measurement System

The system input voltage SYSPWR can be measured by selecting the SYSPWR/xx input of the MUX. Before the system input voltage is supplied to the MUX, the voltage needs to be divided. This is because the variable gain amplifier (VGA) can handle voltages up to 1.5 V, whereas the system voltage can be as high as 20 V. The division is done internally in the DLPA3000. The division factor selection (V_{IN} division factor) is combined with the AUTO_LED_TURN_OFF functionality of the illumination driver.

The LED voltages can be monitored by measuring both the common anode of the LEDs as well as the cathode of each LED individually. The LED anode voltage (V_{LED}) is measured by sensing the feedback pin of the illumination driver (ILLUM_A_FB). Like the SYSPWR, the LED anode voltage needs to be divided before feeding it to the MUX. The division factor is combined with the overvoltage fault level of the illumination driver. The cathode voltages CH1,2,3_SWITCH are fed directly to the MUX without division factor.

The LED current can be determined by knowing the value of sense resistor R_{LIM} and the voltage across the resistor. The voltage at the top-side of the sense resistor can be measured by selecting MUX-input RLIM_K1. The bottom-side of the resistor is connected to GND.

VOTS is connected to an on-chip temperature sensor. The voltage is a measure for the junction temperature of the chip: $Temperature (^{\circ}C) = 300 \times VOTS (V) - 270$,

LABB is a feature that is Local Area Brightness Boost. LABB increases the brightness locally while maintaining good contrast and saturation. The sensor needed for this feature should be connected to pin ACMPR_IN_LABB.

ACMPR_IN_1,2,3 can measure external signals from for instance a temperature sensor. It should be ensured that the voltage on the input does not exceed 1.5 V.

8.3.7 Digital Control

This section discusses the serial protocol interface (SPI) of the DLPA3000, as well as the interrupt handling, device shutdown, and register protection.

8.3.7.1 SPI

The DLPA3000 provides a 4-wire SPI port that supports two SPI clock frequency modes: 0 MHz to 36 MHz, and 20 MHz to 40 MHz. The interface supports both read and write operations. The SPI_SS_Z input serves as the active low chip select for the SPI port. The SPI_SS_Z input must be forced low for writing to or reading from registers. When SPI_SS_Z is forced high, the data at the SPI_MOSI input is ignored, and the SPI_MISO output is forced to a high-impedance state. The SPI_MOSI input serves as the serial data input for the port; the SPI_MISO output serves as the serial data output. The SPI_CLK input serves as the serial data clock for both the input and output data. Data at the SPI_MOSI input is latched on the rising edge of SPI_CLK, while data is clocked out of the SPI_MISO output on the falling edge of SPI_CLK. Figure 8-24 illustrates the SPI port protocol. Byte 0 is referred to as the command byte, where the most significant bit is the write/not-read bit. For the W/nR bit, a 1 indicates a write operation, while a 0 indicates a read operation. The remaining seven bits of the command byte are the register address targeted by the write or read operation. The SPI port supports write and read operations for multiple sequential register addresses through the implementation of an auto-increment mode. As shown in Figure 8-24, the auto-increment mode is invoked by simply holding the SPI_SS_Z input low for multiple data bytes. The register address is automatically incremented after each data byte transferred, starting with the address specified by the command byte. After reaching address 0x7Fh, the address pointer jumps back to 0x00h.

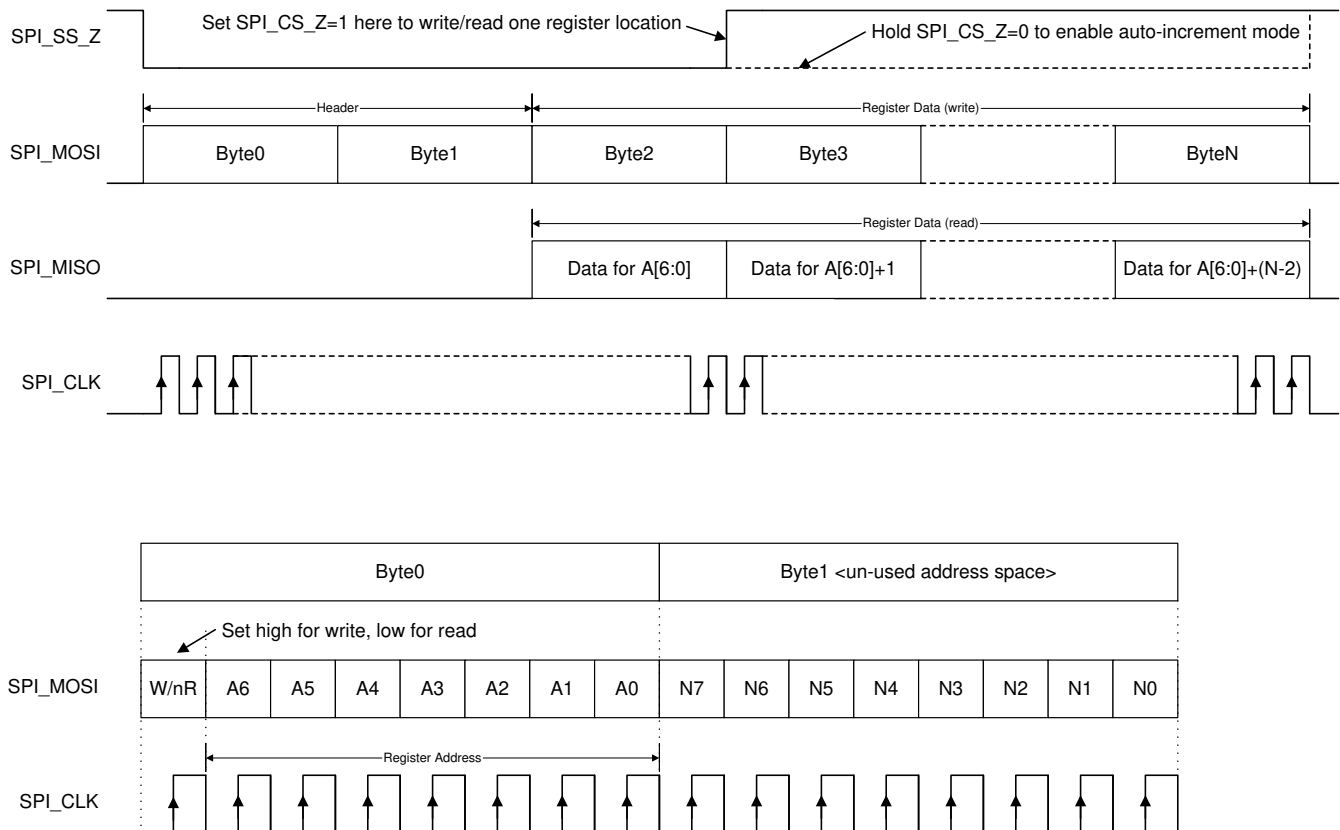

Figure 8-24. SPI Protocol

8.3.7.2 Interrupt

The DLPA3000 power management IC has the capability to flag several faults in the system, such as overheating, low battery, power good, and overvoltage faults. If a certain fault condition occurs, one or more bits in the Table 8-5 are set. Setting a bit in the Main Status register (0x0C) triggers an interrupt event, which

pulls down the INT_Z pin. Interrupts can be masked by setting the respective MASK bits in the [Interrupt Mask register \(0x0D\)](#). Setting a MASK bit prevents the INT_Z from being pulled low for the particular fault condition. The high-level faults can be read in the [Main Status register \(0x0C\)](#), while the lower-level faults can be read in the [Detailed status register1 \(0x27\)](#) through [Detailed status register4 \(0x2A\)](#). [Table 8-5](#) provides an overview of the faults and how they are related.

Table 8-5. Interrupt Registers

HIGH-LEVEL	MID-LEVEL	LOW-LEVEL
SUPPLY_FAULT	DMD_FAULT	DMD_PG_FAULT
		BUCK_DMD1_PG_FAULT
		BUCK_DMD1_OV_FAULT
		BUCK_DMD2_PG_FAULT
		BUCK_DMD2_OV_FAULT
		LDO_GP1_PG_FAULT / LDO_DMD1_PG_FAULT
		LDO_GP1_OV_FAULT / LDO_DMD1_OV_FAULT
		LDO_GP2_PG_FAULT / LDO_DMD2_PG_FAULT
		LDO_GP2_OV_FAULT / LDO_DMD2_OV_FAULT
		BUCK_GP2_PG_FAULT
BUCK_GP2_OV_FAULT		
ILLUM_FAULT		ILLUM_BC1_PG_FAULT
		ILLUM_BC1_OV_FAULT
		ILLUM_BC2_PG_FAULT
		ILLUM_BC2_OV_FAULT
PROJ_ON_INT		
BAT_LOW_SHUT		
BAT_LOW_WARN		
TS_SHUT		
TS_WARN		

8.3.7.3 Fast-Shutdown in Case of Fault

The DLPA3000 has two shutdown modes: a normal shutdown initiated after pulling PROJ_ON level low, and a fast power-down mode. The fast power-down feature can be enabled or disabled through register [FAST_SHUTDOWN_EN](#) (0x01, bit 7). By default, the mode is enabled.

When the fast power-down feature is enabled, a fast shutdown is initiated for specific faults. This shutdown happens autonomously from the DLPC. The DLPA3000 enters the fast shutdown mode only for specific faults, thus not for all the faults flagged by the DLPA3000. The faults for which the DLPA3000 goes into fast-shutdown are listed in [Table 8-6](#).

Table 8-6. Faults that Trigger a Fast-Shutdown

HIGH-LEVEL	LOW-LEVEL
BAT_LOW_SHUT	
TS_SHUT	
DMD_FAULT	DMD_PG_FAULT
	BUCK_DMD1_PG_FAULT
	BUCK_DMD1_OV_FAULT
	BUCK_DMD2_PG_FAULT
	BUCK_DMD2_OV_FAULT
	LDO_GP1_PG_FAULT / LDO_DMD1_PG_FAULT
	LDO_GP1_OV_FAULT / LDO_DMD1_OV_FAULT
	LDO_GP2_PG_FAULT / LDO_DMD2_PG_FAULT
	LDO_GP2_OV_FAULT / LDO_DMD2_OV_FAULT
ILLUM_FAULT	ILLUM_BC1_OV_FAULT
	ILLUM_BC2_OV_FAULT

8.4 Device Functional Modes

Table 8-7. Modes of Operation

MODE	DESCRIPTION
OFF	This is the lowest-power mode of operation. All power functions are turned off, registers are reset to their default values, and the IC does not respond to SPI commands. RESET_Z pin is pulled low. The IC will enter OFF mode whenever the PROJ_ON pin is low.
WAIT	The DMD regulators and LED power (V_{LED}) are turned off, but the IC does respond to the SPI. The device enters WAIT mode whenever PROJ_ON is set high, DMD_EN ⁽¹⁾ bit is set to 0 or a FAULT is resolved.
STANDBY	The device also enters STANDBY mode when a fault condition is detected. ⁽²⁾ (See <i>Interrupt</i>). Once the fault condition is resolved, WAIT mode is entered.
ACTIVE1	The DMD supplies are enabled but LED power (V_{LED}) is disabled. PROJ_ON pin must be high, DMD_EN bit must be set to 1, and ILLUM_EN ⁽³⁾ bit is set to 0.
ACTIVE2	DMD supplies and LED power are enabled. PROJ_ON pin must be high and DMD_EN and ILLUM_EN bits must both be set to 1.

- (1) Settings can be done through [Enable register](#), bit is named DMD_EN
(2) Power-good faults, overvoltage, overtemperature shutdown, and undervoltage lockout
(3) Settings can be done through register [Enable register](#), bit is named ILLUM_EN

Table 8-8. Device State as a Function of Control-Pin Status

PROJ_ON Pin	STATE
LOW	OFF
HIGH	WAIT STANDBY ACTIVE1 ACTIVE2 (Device state depends on DMD_EN and ILLUM_EN bits and whether there are any fault conditions.)

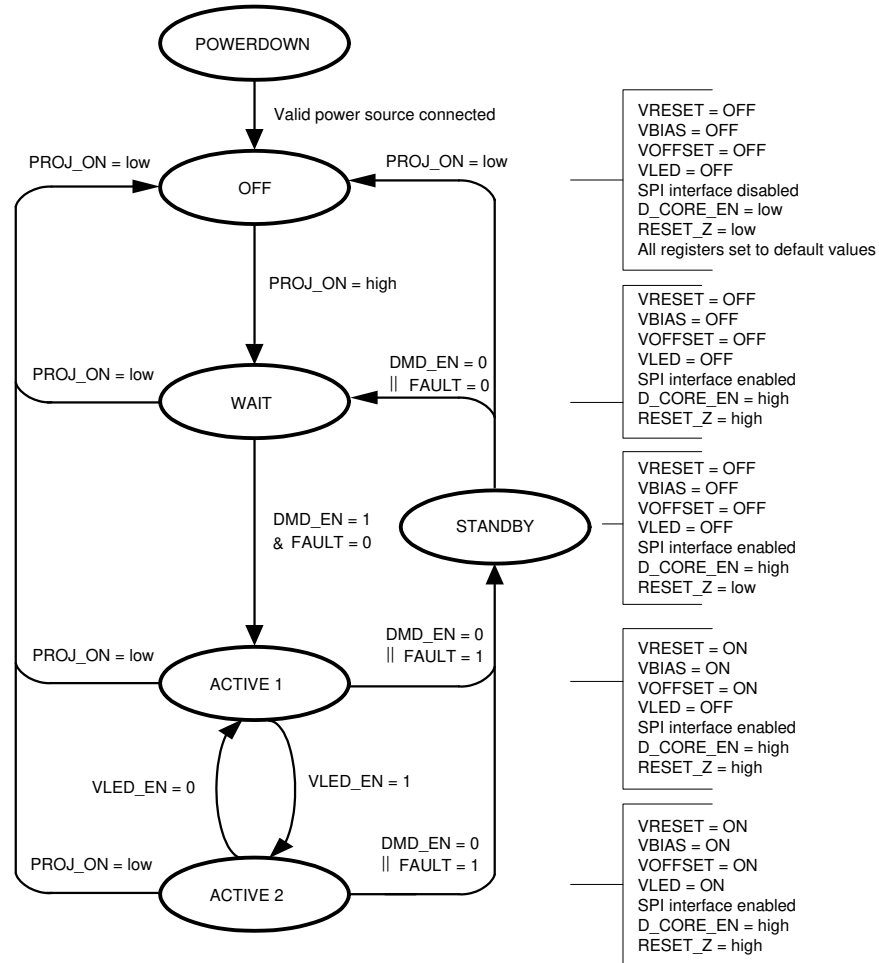

- A. || = OR, & = AND
- B. FAULT = undervoltage on any supply, thermal shutdown, or UVLO detection
- C. UVLO detection, per the diagram, causes the DLPA3000 to go into the standby state. This is not the lowest power state. If lower power is desired, PROJ_ON should be set low.
- D. DMD_EN register bit can be reset or set by SPI writes. DMD_EN defaults to 0 when PROJ_ON goes from low to high and then the DPP ASIC software automatically sets it to 1. Also, FAULT = 1 causes the DMD_EN register bit to be reset.
- E. D_CORE_EN is a signal internal to the DLPA3000. This signal turns on the VCORE regulator.

Figure 8-25. State Diagram

8.5 Register Maps

Register Address, Default, R/W, Register name. **Boldface** settings are the hardwired defaults.

Table 8-9. Register Map

NAME	BITS	DESCRIPTION
0x00, D3, R/W, Chip Identification		
CHIPID	[7:4]	Chip identification number: D (hex)
REVID	[3:0]	Revision number, 3 (hex)
0x01, 82, R/W, Enable Register		
FAST_SHUTDOWN_EN	[7]	0: Fast shutdown disabled 1: Fast shutdown enabled
CW_EN	[6]	Reserved, value default as 0
BUCK_GP3_EN	[5]	Reserved, value default as 0
BUCK_GP2_EN	[4]	0: General purpose buck2 disabled 1: General purpose buck2 enabled
BUCK_GP1_EN	[3]	Reserved, value default as 0
ILLUM_LED_AUTO_OFF_EN	[2]	0: Illum_led_auto_off_en disabled 1: Illum_led_auto_off_en enabled
ILLUM_EN	[1]	0: Illum regulators disabled 1: Illum regulators enabled
DMD_EN	[0]	0: DMD regulators disabled 1: DMD regulators enabled
0x02, 70, R/W, IREG Switch Control		
TBD	[7]	Reserved, value does not matter.
ILLUM_ILIM	[6:3]	Rlim voltage top-side (mV). Illum current limit = Rlim voltage / Rlim
		0000: 17 1000: 73
		0001: 20 1001: 88
		0010: 23 1010: 102
		0011: 25 1011: 117
		0100: 29 1100: 133
		0101: 37 1101: 154
		0110: 44 1110: 176
0111: 59 1111: 197		
ILLUM_SW_ILIM_EN	[2:0]	Bit2: CH3, MOSFET R transient current limit (0:disabled , 1:enabled) Bit1: CH2, MOSFET Q transient current limit (0:disabled , 1:enabled) Bit0: CH1, MOSFET P transient current limit (0:disabled , 1:enabled)
0x03, 00, R/W, SW1_IDAC(1)		
TBD	[7:2]	Reserved, value does not matter.
SW1_IDAC<9:8>	[1:0]	Led current of CH1(A) = ((Bit value + 1)/1024) × (150 mV / Rlim), Most significant bits of 10 bits register (register 0x03 and 0x04). 00 0000 0000 [OFF] 00 0011 0011 [(52/1024) × (150mV/Rlim)], Minimum code. 11 1111 1111 [150mV/Rlim]
0x04, 00, R/W, SW1_IDAC(2)		
SW1_IDAC<7:0>	[7:0]	Led current of CH1(A) = ((Bit value + 1)/1024) × (150 mV / Rlim), Least significant bits of 10 bits register (register 0x03 and 0x04). 00 0000 0000 [OFF] 00 0011 0011 [(52/1024) × (150mV/Rlim)], Minimum code. 11 1111 1111 [150mV/Rlim]

Table 8-9. Register Map (continued)

NAME	BITS	DESCRIPTION
0x05, 00, R/W, SW2_IDAC(1)		
TBD	[7:2]	Reserved, value does not matter.
SW2_IDAC<9:8>	[1:0]	Led current of CH2(A) = ((Bit value + 1)/1024) × (150 mV / Rlim), Most significant bits of 10 bits register (register 0x05 and 0x06). 00 0000 0000 [OFF] 00 0011 0011 [(52/1024) × (150mV/Rlim)], Minimum code. 11 1111 1111 [150mV/Rlim]
0x06, 00, R/W, SW2_IDAC(2)		
SW2_IDAC<7:0>	[7:0]	Led current of CH2(A) = ((Bit value + 1)/1024) × (150 mV / Rlim), Least significant bits of 10 bits register (register 0x05 and 0x06). 00 0000 0000 [OFF] 00 0011 0011 [(52/1024) × (150mV/Rlim)], Minimum code. 11 1111 1111 [150mV/Rlim]
0x07, 00, R/W, SW3_IDAC(1)		
TBD	[7:2]	Reserved, value does not matter.
SW3_IDAC<9:8>	[1:0]	Led current of CH3(A) = ((Bit value + 1)/1024) × (150 mV / Rlim), Most significant bits of 10 bits register (register 0x07 and 0x08). 00 0000 0000 [OFF] 00 0011 0011 [(52/1024) × (150mV/Rlim)], Minimum code. 11 1111 1111 [150mV/Rlim]
0x08, 00, R/W, SW3_IDAC(2)		
SW3_IDAC<7:0>	[7:0]	Led current of CH3(A) = ((Bit value + 1)/1024) × (150 mV / Rlim), Least significant bits of 10 bits register (register 0x07 and 0x08). 00 0000 0000 [OFF] 00 0011 0011 [(52/1024) × (150mV/Rlim)], Minimum code. 11 1111 1111 [150mV/Rlim]
0x0C, 00, R, Main Status Register		
SUPPLY_FAULT	[7]	0: No PG or OV failures for any of the LV Supplies 1: PG failures for a LV Supplies
ILLUM_FAULT	[6]	0: ILLUM_FAULT = LOW 1: ILLUM_FAULT = HIGH
PROJ_ON_INT	[5]	0: PROJ_ON = HIGH 1: PROJ_ON = LOW
DMD_FAULT	[4]	0: DMD_FAULT = LOW 1: DMD_FAULT = HIGH
BAT_LOW_SHUT	[3]	0: VIN > UVLO_SEL<4:0> 1: VIN < UVLO_SEL<4:0>
BAT_LOW_WARN	[2]	0: VIN > LOWBATT_SEL<4:0> 1: VIN < LOWBATT_SEL<4:0>
TS_SHUT	[1]	0: Chip temperature < 132.5°C and no violation in V5V0 1: Chip temperature > 156.5°C, or violation in V5V0
TS_WARN	[0]	0: Chip temperature < 121.4°C 1: Chip temperature > 123.4°C

Table 8-9. Register Map (continued)

NAME	BITS	DESCRIPTION
0x0D, F5, Interrupt Mask Register		
SUPPLY_FAULT_MASK	[7]	0: Not masked for SUPPLY_FAULT interrupt 1: Masked for SUPPLY_FAULT interrupt
ILLUM_FAULT_MASK	[6]	0: Not masked for ILLUM_FAULT interrupt 1: Masked for ILLUM_FAULT interrupt
PROJ_ON_INT_MASK	[5]	0: Not masked for PROJ_ON_INT interrupt 1: Masked for PROJ_ON_INT interrupt
DMD_FAULT_MASK	[4]	0: Not masked for DMD_FAULT interrupt 1: Masked for DMD_FAULT interrupt
BAT_LOW_SHUT_MASK	[3]	0: Not masked for BAT_LOW_SHUT interrupt 1: Masked for BAT_LOW_SHUT interrupt
BAT_LOW_WARN_MASK	[2]	0: Not masked for BAT_LOW_WARN interrupt 1: Masked for BAT_LOW_WARN interrupt
TS_SHUT_MASK	[1]	0: Not masked for TS_SHUT interrupt 1: Masked for TS_SHUT interrupt
TS_WARN_MASK	[0]	0: Not masked for TS_WARN interrupt 1: Masked for TS_WARN interrupt
0x27, 00, R, Detailed status register1 (Power good failures for general purpose and illumination blocks)		
BUCK_GP3_PG_FAULT	[7]	Reserved, value default as 0
BUCK_GP1_PG_FAULT	[6]	Reserved, value default as 0
BUCK_GP2_PG_FAULT	[5]	0: No fault 1: General purpose buck2 power good failure. Does not initiate a fast shutdown.
Reserved	[4]	
ILLUM_BC1_PG_FAULT	[3]	0: No fault 1: Illum buck converter1 power good failure. Does not initiate a fast shutdown.
ILLUM_BC2_PG_FAULT	[2]	0: No fault 1: Illum buck converter2 power good failure. Does not initiate a fast shutdown.
TBD	[1]	Reserved, value always 0
TBD	[0]	Reserved, value always 0
0x28, 00, R, Detailed status register2 (Overvoltage failures for general purpose and illum blocks)		
BUCK_GP3_OV_FAULT	[7]	Reserved, value default as 0
BUCK_GP1_OV_FAULT	[6]	Reserved, value default as 0
BUCK_GP2_OV_FAULT	[5]	0: No fault 1: General purpose buck2 overvoltage failure. Does not initiate a fast shutdown.
TBD	[4]	Reserved, value always 0
ILLUM_BC1_OV_FAULT	[3]	0: No fault 1: Illum buck converter1 overvoltage failure. Does not initiate a fast shutdown.
ILLUM_BC2_OV_FAULT	[2]	0: No fault 1: Illum buck converter2 overvoltage failure. Does not initiate a fast shutdown.
TBD	[1]	Reserved, value always 0
TBD	[0]	Reserved, value always 0
0x29, 00, R, Detailed status register3 (Power good failure for DMD related blocks)		
TBD	[7]	Reserved, value always 0
DMD_PG_FAULT	[6]	0: No fault 1: VBIAS, VOFS and/or VRST power good failure. Initiates a fast shutdown.
BUCK_DMD1_PG_FAULT	[5]	0: No fault 1: Buck1 (used to create DMD voltages) power good failure. Initiates a fast shutdown.
BUCK_DMD2_PG_FAULT	[4]	0: No fault 1: Buck2 (used to create DMD voltages) power good failure. Initiates a fast shutdown.
TBD	[3]	Reserved, value always 0
TBD	[2]	Reserved, value always 0

Table 8-9. Register Map (continued)

NAME	BITS	DESCRIPTION
LDO_GP1_PG_FAULT / LDO_DMD1_PG_FAULT	[1]	0: No fault 1: LDO1 (used as general purpose or DMD specific LDO) power good failure. Initiates a fast shutdown.
LDO_GP2_PG_FAULT / LDO_DMD2_PG_FAULT	[0]	0: No fault 1: LDO2 (used as general purpose or DMD specific LDO) power good failure. Initiates a fast shutdown.
0x2A, 00, R, Detailed status register4 (Overvoltage failures for DMD related blocks and Color Wheel)		
TBD	[7]	Reserved, value always 0
TBD	[6]	Reserved, value always 0
BUCK_DMD1_OV_FAULT	[5]	0: No fault 1: Buck1 (used to create DMD voltage) overvoltage failure
BUCK_DMD2_OV_FAULT	[4]	0: No fault 1: Buck2 (used to create DMD voltage) overvoltage failure
TBD	[3]	Reserved, value always 0
TBD	[2]	Reserved, value always 0
LDO_GP1_OV_FAULT / LDO_DMD1_OV_FAULT	[1]	0: No fault 1: LDO1 (used as general purpose or DMD specific LDO) overvoltage failure
LDO_GP2_OV_FAULT / LDO_DMD2_OV_FAULT	[0]	0: No fault 1: LDO2 (used as general purpose or DMD specific LDO) overvoltage failure

9 Application and Implementation

Note

Information in the following applications sections is not part of the TI component specification, and TI does not warrant its accuracy or completeness. TI's customers are responsible for determining suitability of components for their purposes, as well as validating and testing their design implementation to confirm system functionality.

9.1 Application Information

In display applications, using the DLPA3000 provides all needed analog functions including all analog power supplies and the RGB LED driver (up to 6 A per LED) to provide a robust and efficient display product. Each DLP application is derived primarily from the optical architecture of the system and the format of the data coming into the DLPC343x DLP controller chip.

9.2 Typical Applications

9.2.1 Typical Application Setup Using DLPA3000

A common application when using DLPA3000 is to use it with a DLP3010 DMD and DLPC3433/DLPC3438 controller for creating a small, ultra-portable projector. The DLPC3433/DLPC3438 in the projector typically receives images from a PC or video player using HDMI or VGA analog, as shown in Figure 9-1. Card readers and Wi-Fi can also be used to receive images if the appropriate peripheral chips are added. The DLPA3000 provides power supply sequencing and control of the RGB LED currents as required by the application.

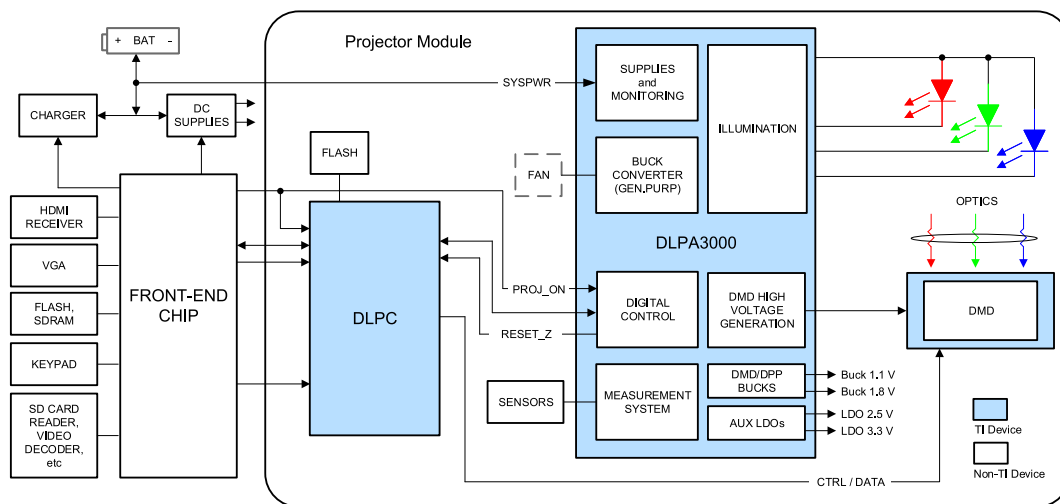

Figure 9-1. Typical Setup Using DLPA3000

9.2.1.1 Design Requirements

An ultra-portable projector can be created by using a DLP chip set comprised of a DLP3010 (.3 720) DMD, a DLPC3433 or DLPC3438 controller, and the DLPA3000 PMIC/LED Driver. The DLPC3433 or DLPC3438 does the digital image processing, the DLPA3000 provides the needed analog functions for the projector, and DMD is the display device for producing the projected image. In addition to the three DLP chips in the chipset, other chips may be needed. At a minimum, a Flash part is needed to store the software and firmware to control the DLPC3433 or DLPC3438. The illumination light that is applied to the DMD is typically from red, green, and blue LEDs. These are often contained in three separate packages, but sometimes more than one color of LED die may be in the same package to reduce the overall size of the projector. For connecting the DLPC3433 or DLPC3438 to the front-end chip for receiving images, the parallel interface is typically used. While using the parallel interface, I²C should be connected to the front-end chip for inputting commands to the DLPC3433 or DLPC3438.

The DLPA3000 has five built-in buck switching regulators to serve as projector system power supplies. Two of the regulators are fixed to 1.1 V and 1.8 V for powering the DLP chipset. The remaining three buck regulators are available for general purpose use and their voltages are programmable. These three programmable regulators can be used to drive variable-speed fans or to power other projector chips, such as the front-end chip. The only power supply needed at the DLPA3000 input is SYSPWR from an external DC power supply or internal battery. The entire projector can be turned on and off by using a single signal called PROJ_ON. When PROJ_ON is high, the projector turns on and begins displaying images. When PROJ_ON is set low, the projector turns off and draws just microamps of current on SYSPWR.

9.2.1.2 Detailed Design Procedure

For connecting the DLP3010, DLPC3433 or DLPC3438 and DLPA3000 together, see the reference design schematic. When a circuit board layout is created from this schematic, a very small circuit board is possible. An example small-board layout is included in the reference design database. Layout guidelines should be followed to achieve reliable projector operation. The optical engine that has the LED packages and the DMD mounted to it is typically supplied by an optical OEM who specializes in designing optics for DLP projectors.

9.2.1.3 Application Curve

As the LED currents that are driven time-sequentially through the red, green, and blue LEDs are increased, the brightness of the projector increases. This increase is somewhat non-linear, and the curve for typical white-screen lumens changes with LED currents, as shown in Figure 9-2. For the LED currents shown, it is assumed that the same current amplitude is applied to the red, green, and blue LEDs. The thermal solution used to heatsink the red, green, and blue LEDs can significantly alter the curve shape shown.

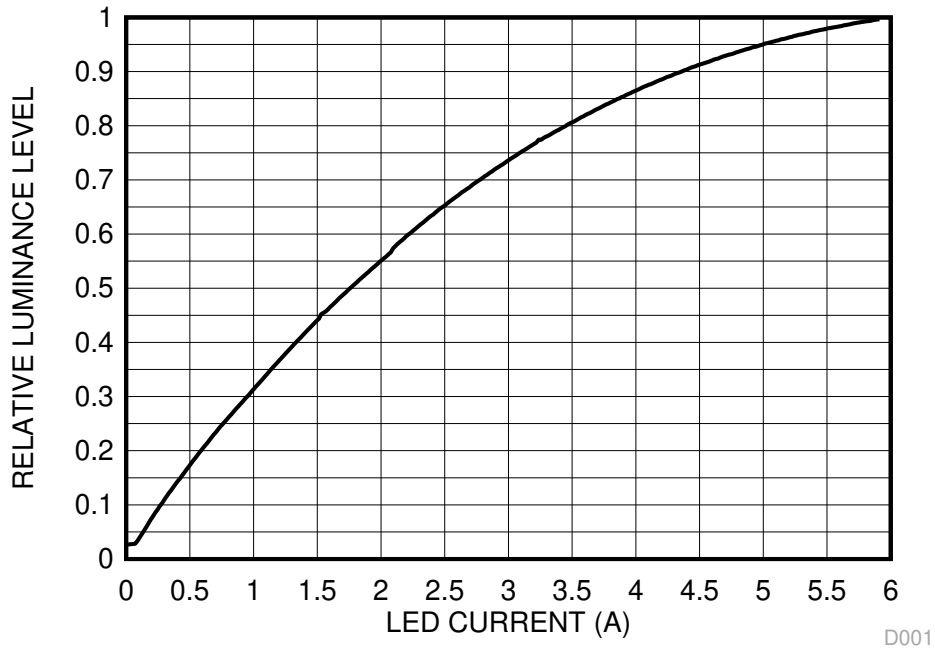

Figure 9-2. Luminance vs LED Current

9.2.2 Typical Application with DLPA3000 Internal Block Diagram

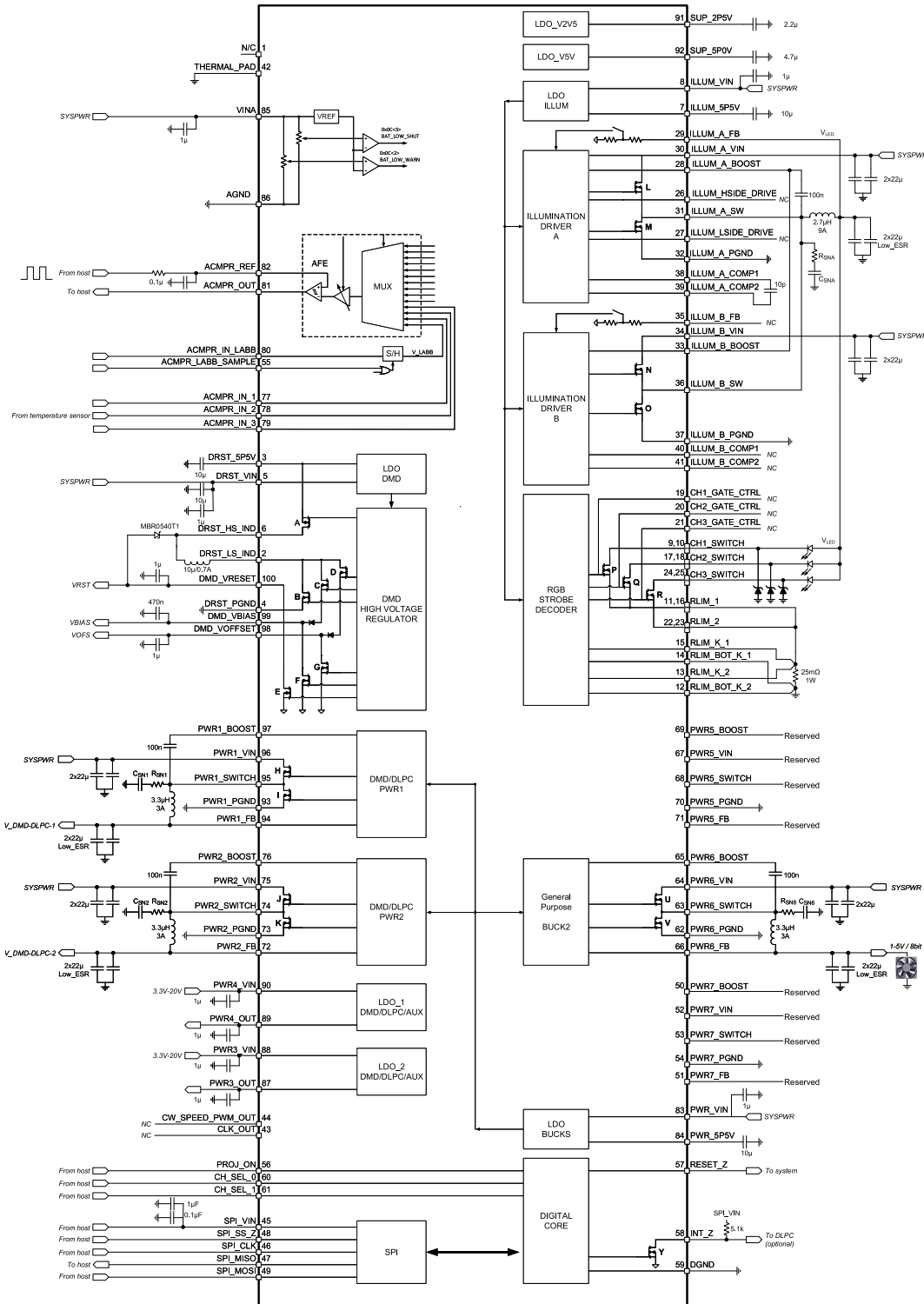

Figure 9-3. Typical Application: VIN = 12 V, IOU = 6 A, LED

Note

The voltage rating of the capacitor must be equal or greater than two times the applied voltage across the capacitor in the application.

10 Power Supply Recommendations

The DLPA3000 is designed to operate from a 6 V to 20 V input voltage supply or battery. To avoid insufficient supply current due to line drop, ringing due to trace inductance at the VIN terminals, or supply peak current limitations, additional bulk capacitance may be required. In the case of ringing that is caused by the interaction with the ceramic input capacitors, an electrolytic or tantalum type capacitor may be needed for damping.

The amount of bulk capacitance required should be evaluated such that the input voltage can remain in spec long enough for a proper fast shutdown to occur for the V_{OFFSET} , V_{RESET} , and V_{BIAS} supplies. The shutdown begins when the input voltage drops below the programmable UVLO threshold, such as when the external power supply or battery supply is suddenly removed from the system.

11 Layout

11.1 Layout Guidelines

For switching power supplies, the layout is an important step in the design process, especially when it concerns high-peak currents and high-switching frequencies. If the layout is not carefully done, the regulator could show stability issues and/or EMI problems. Therefore, it is recommended to use wide- and short-traces for high-current paths and for their return power ground paths. The input capacitor, output capacitor, and inductor should be placed as near as possible to the IC. In order to minimize ground noise coupling between different buck converters, it is advised to separate their grounds and connect them at a central point under the part.

The high currents of the buck converters concentrate around pins V_{IN} , SWITCH and P_{GND} (Figure 11-1). The voltage at the pins V_{IN} , P_{GND} , and FB are DC voltages while the pin SWITCH has a switching voltage between V_{IN} and P_{GND} . In case the FET between pins 63 and 64 is closed, the red line indicates the current flow while the blue line indicates the current flow when the FET between pins 62 and 63 is closed. These paths carry the highest currents and must be kept as short as possible.

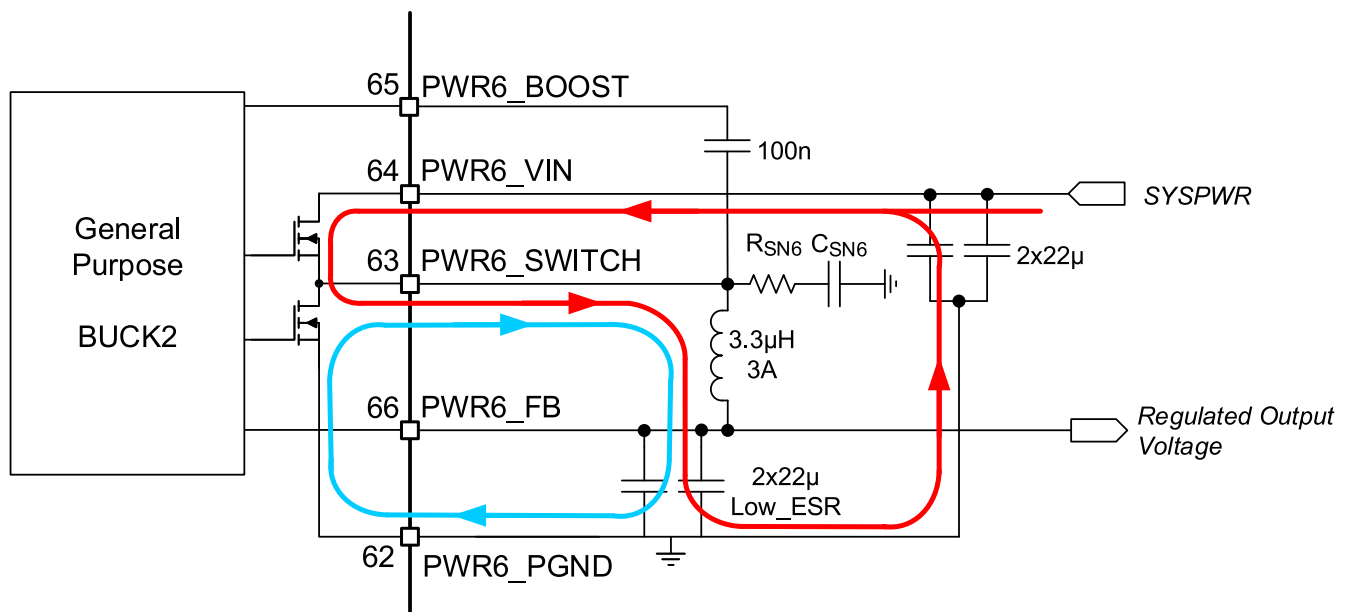

Figure 11-1. High AC Current Paths in a Buck Converter

The trace to the V_{IN} pin carries high AC currents. Therefore, the trace should be low-resistive to prevent voltage drop across the trace. Additionally, the decoupling capacitors should be placed as near to the V_{IN} pin as possible.

The SWITCH pin is connected alternately to the V_{IN} or GND. This means a square wave voltage is present on the SWITCH pin with an amplitude of V_{IN} and containing high frequencies. This can lead to EMI problems if not properly handled. To reduce EMI problems a snubber network (R_{SN6} and C_{SN6}) is placed at the SWITCH pin to prevent and/or suppress unwanted high-frequency ringing at the moment of switching.

The P_{GND} pin sinks high current and should be connected to a star ground point such that it does not interfere with other ground connections.

The FB pin is the sense connection for the regulated output voltage, which is a DC voltage; no current is flowing through this pin. The voltage on the FB pin is compared with the internal reference voltage in order to control the loop. The FB connection should be made at the load such that $I \cdot R$ drop is not affecting the sensed voltage.

11.2 Layout Example

Figure 11-2 shows a layout example of a buck converter, illustrating the optimal routing and placement of components around the DLPA3000. Use this as a reference for a general purpose buck2 (PWR6). The layout

example illustrates the inductor and its accompanying capacitors are as close as possible to their corresponding pins, using the thickest possible traces. The capacitors use multiple vias to the ground layer to maintain a low resistance path and minimize the distance between the ground connections of the output capacitors and the ground connections of the buck converter.

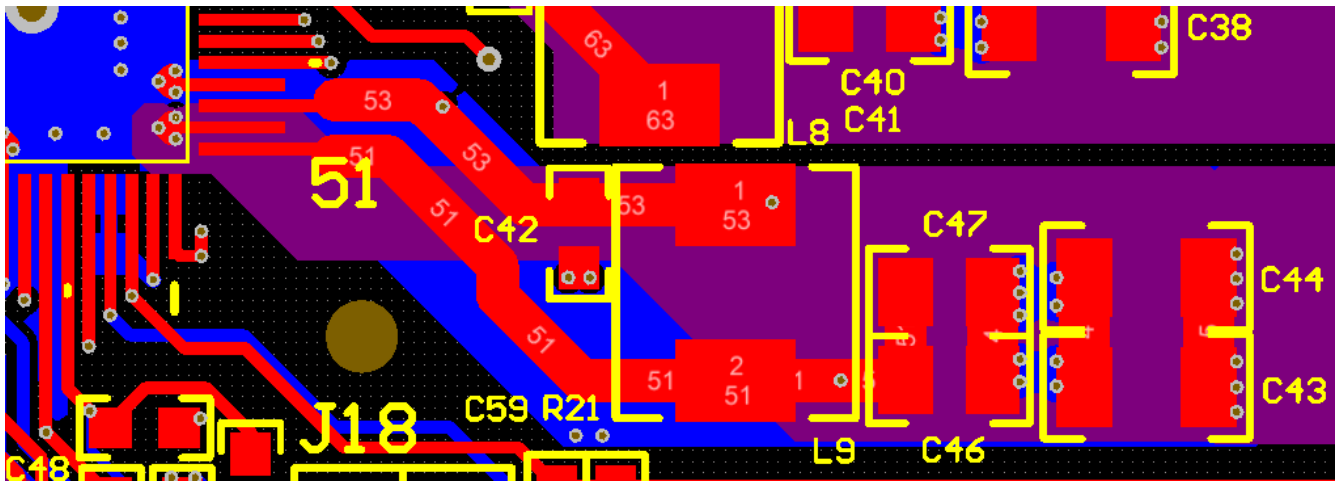

Figure 11-2. Practical Layout

A proper layout requires short traces and separate power grounds to avoid losses from trace resistance and to avoid ground shifting. Use high quality capacitors with low ESR to keep capacitor losses minimal and to maintain an acceptable voltage ripple at the output.

Use a RC snubber network to avoid EMI that can occur when switching high currents at high frequencies. The EMI may have a higher amplitude and frequency than the switching voltage.

11.3 SPI Connections

The SPI interface consists of several digital lines and the SPI supply. If routing of the interface lines is not done properly, communication errors can occur. It should be prevented that SPI lines can pickup noise and possible interfering sources should be kept away from the interface.

Pickup of noise can be prevented by ensuring that the SPI ground line is routed together with the digital lines as much as possible to the respective pins. The SPI interface should be connected by a separate own ground connection to the DGND of the DLPA3000 (Figure 11-3). This prevents ground noise between SPI ground references of DLPA3000 and DLPC due to the high current in the system.

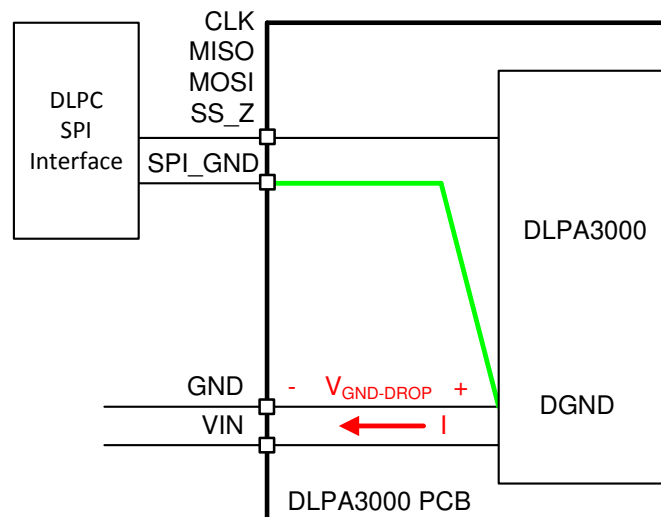

Figure 11-3. SPI Connections

Interfering sources should be kept away from the interface lines as much as possible. If any power lines are routed too close to the SPI_CLK, it is possible it will lead to false clock pulses and, thus, communication errors.

11.4 R_{LIM} Routing

R_{LIM} senses the LED current. To accurately measure the LED current, connect the RLIM_K_1,2 lines close to the top-side of measurement resistor R_{LIM}, while RLIM_BOT_K_1,2 should be connected close to the bottom-side of R_{LIM}. RLIM_K_1,2 and RLIM_BOT_K_1,2 should all have separate traces from their IC pins to their RLIM connection point.

The switched LED current is running through R_{LIM}. Therefore, a low-ohmic ground connection for R_{LIM} is strongly advised.

11.5 LED Connection

High switching currents run through the wiring connecting the external RGB switches and the LEDs. Therefore, special attention needs to be paid here. Two perspectives apply to the LED-to-RGB wiring:

1. The resistance of the wiring, R_{series}
2. The inductance of the wiring, L_{series}

The location of the parasitic series impedances IS depicted in [Figure 11-4](#).

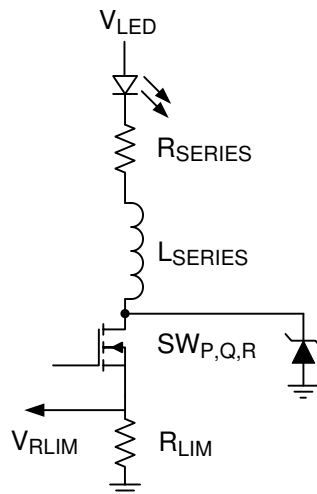

Figure 11-4. Parasitic Inductance (L_{series}) and Resistance (R_{series}) in Series with LED

Currents up to 6 A can run through the wires connecting the LEDs to the DLPA3000. Some noticeable dissipation can easily be caused. Every 10 mΩ of series resistances implies for 6 A average LED current a parasitic power dissipation of 0.36 W. This might cause PCB heating, but more importantly, the overall system efficiency is deteriorated.

Additionally, the resistance of the wiring might impact the control dynamics of the LED current. It should be noted that the routing resistance is part of the LED current control loop. The LED current is controlled by V_{LED}. For a small change in V_{LED} (ΔV_{LED}) the resulting LED current variation (ΔI_{LED}) is given by the total differential resistance in that path:

$$\Delta I_{LED} = \frac{\Delta V_{LED}}{r_{LED} + R_{series} + R_{on_SW_P,Q,R} + R_{LIM}} \quad (10)$$

in which r_{LED} is the differential resistance of the LED and R_{on_SW_P,Q,R} the on resistance of the strobe decoder switch. In this expression, L_{series} is ignored since realistic values are usually sufficiently low to cause any noticeable impact on the dynamics.

All the comprising differential resistances are in the range of 25 mΩ to several 100s mΩ. Without paying special attention, a series resistance of 100 mΩ can easily be obtained. It is advised to keep this series resistance sufficiently low, that is, <50 mΩ.

The series inductance plays an important role when considering the switched nature of the LED current. While cycling through R, G, and B LEDs, the current through these branches is turned-on and turned-off in short-time duration. Specifically, turning-off is fast. A current of 6 A goes to 0 A in a matter of 50 ns. This implies a voltage spike of about 1 V for every 10 nH of parasitic inductance. It is recommended to minimize the series inductance of the LED wiring by:

- Short wires
- Thick wires / multiple parallel wires
- Small enclosed area of the forward and return current path

If the inductance cannot be made sufficiently low, a Zener diode needs to be used to clamp the drain voltage of the RGB switch, such it does not surpass the absolute maximum rating. The clamping voltage needs to be chosen between the maximum expected V_{LED} and the absolute maximum rating. Take care of sufficient margin of the clamping voltage relative to the mentioned minimum and maximum voltage.

11.6 Thermal Considerations

Power dissipation must be considered when implementing integrated circuits in low-profile and fine-pitch surface-mount packages. Many system related issues may affect power dissipation: thermal coupling, airflow, adding heat sinks and convection surfaces, and the presence of other heat-generating components. In general, there are three basic methods that can be used to improve thermal performance:

- Improving the heat sinking capability of the PCB
- Reducing thermal resistance to the environment of the chip by adding or increasing heat sink capability on top of the package
- Adding or increasing airflow in the system

Power delivered to the LEDs can be greater than 30 W and the power dissipated by the DLPA3000 can be considerable. For proper DLPA3000 operation, the details below outline thermal considerations for a DLPA3000 application.

The recommended junction temperature for the DLPA3000 is below 120°C during operation. The equation that relates junction temperature, $T_{junction}$, is given by:

$$T_{junction} = T_{ambient} + P_{diss} \cdot R_{\theta JA} \quad (11)$$

where $T_{ambient}$ is the ambient temperature, P_{diss} is the total power dissipation, and $R_{\theta JA}$ is the thermal resistance from junction to ambient.

The total power dissipation may vary depending on the application of the DLPA3000. The main contributors in the DLPA3000 are typically:

- Buck converters
- RGB strobe decoder switches
- LDOs

For the buck converter, the dissipated power is given by:

$$P_{diss_buck} = P_{in} - P_{out} = P_{out} \left(\frac{1}{\eta_{buck}} - 1 \right) \quad (12)$$

where η_{buck} is the efficiency of the buck converter, P_{in} is the power delivered at the input of the buck converter, and P_{out} is the power delivered to the load of the buck converter. For the buck converter PWR1,2,6, the efficiency can be determined using the curves in [Figure 7-22](#).

Similarly, for the buck converter in the illumination block, the dissipated power $P_{\text{diss_illum_buck}}$ can be calculated using the expression for $P_{\text{diss_buck}}$. For the illumination block, an extra term needs to be added to the dissipation; that is, the dissipation of the LED switch. So, the dissipation for the illumination block, $P_{\text{diss_illum}}$, can be described by:

$$P_{\text{diss_illum}} = P_{\text{out_LEDs}} \left(\frac{1}{\eta_{\text{illum_buck}}} - 1 \right) + I_{\text{LED_avg}}^2 \cdot R_{\text{sw_PQR}} \quad (13)$$

where $P_{\text{out-LEDs}}$ represents the total power supplied to the LEDs, $I_{\text{LED_avg}}$ is the average LED current, and $R_{\text{sw_PQR}}$ is the on-resistance of the RGB strobe controller switches. It should be noted here that the sense resistor, R_{LIM} , also carries the average LED current, but it is not added to the equation of the dissipation for the illumination block. The R_{LIM} is external to the DLPA3000 and it does not contribute the heat directly to the DLPA3000. For the total system dissipation, R_{LIM} should be included.

For the LDO, the power dissipation is given by:

$$P_{\text{diss_LDO}} = (V_{\text{in}} - V_{\text{out}}) \cdot I_{\text{load}} \quad (14)$$

where V_{in} is the input supply voltage, V_{out} is the output voltage of the LDO, and I_{load} is the load current of the LDO.

The voltage drops over the LDO ($V_{\text{in}} - V_{\text{out}}$) can be relatively large; a small load current can result in significant power dissipation. For this situation, a general purpose buck converter can be a more efficient solution.

The LDO DMD provides power to the boost converter, and the boost converter provides high voltages for the DMD; that is, V_{BIAS} , V_{OFS} , V_{RST} . The current load on these lines can increase up to $I_{\text{load,max}} = 10$ mA. Assuming the efficiency of the boost converter, η_{boost} , is 80%, the maximum boost converter power dissipation, $P_{\text{diss_DMD_boost,max}}$, can be calculated as:

$$P_{\text{diss_DMD_boost,max}} = I_{\text{load,max}} (V_{\text{BIAS}} + V_{\text{OFS}} + |V_{\text{RST}}|) \cdot \left(\frac{1}{\eta_{\text{boost}}} - 1 \right) \approx 0.1\text{W} \quad (15)$$

Compared to the power dissipation of the illumination buck converter, the power dissipation of the boost converter is negligible. However, the power dissipation of the LDO DMD, $P_{\text{diss_LDO_DMD}}$ should be given consideration in the case of a high supply voltage. The worst-case load current for the LDO is given by:

$$I_{\text{load_LDO,max}} = \frac{1}{\eta_{\text{boost}}} \frac{(V_{\text{BIAS}} + V_{\text{OFS}} + |V_{\text{RST}}|)}{V_{\text{DRST_5P5V}}} I_{\text{load,max}} \approx 100\text{mA} \quad (16)$$

where the output voltage of the LDO is $V_{\text{DRST_5P5V}} = 5.5$ V.

The worst-case power dissipation of the LDO DMD is approximately 1.5 W when the input supply voltage is 19.5 V. For your specific application, it is recommended to check the LDO current level. Therefore, the total power dissipation of the DLPA3000 can be described as:

$$P_{\text{diss_DLPA_3000}} = \sum P_{\text{buck_converters}} + \sum P_{\text{illumination}} + \sum P_{\text{LDOs}} \quad (17)$$

The following examples calculate of the maximum ambient temperature and the junction temperature based on known information.

If it is assumed that the total dissipation $P_{\text{diss_DLPA3000}} = 7.5$ W, $T_{\text{junction,max}} = 120$ °C, $R_{\theta\text{JA}} = 7$ °C/W (refer to [Thermal Information](#)), then the maximum ambient temperature can be calculated using [Equation 11](#):

$$T_{\text{ambient,max}} = T_{\text{junction,max}} - P_{\text{diss}} \cdot R_{\theta\text{JA}} = 120^{\circ}\text{C} - 7.5\text{W} \cdot 7^{\circ}\text{C}/\text{W} = 67.5^{\circ}\text{C} \quad (18)$$

If the total power dissipation and the ambient temperature are known as:

$$T_{\text{ambient}} = 50^{\circ}\text{C}, R_{\theta\text{JA}} = 7^{\circ}\text{C}/\text{W}, P_{\text{diss_DLPA3000}} = 7.5\text{W}.$$

the junction temperature can be calculated:

$$T_{\text{junction}} = T_{\text{ambient}} + P_{\text{diss}} \cdot R_{\theta\text{JA}} = 50^{\circ}\text{C} + 7.5\text{W} \cdot 7^{\circ}\text{C}/\text{W} = 102.5^{\circ}\text{C} \quad (19)$$

If the combination of ambient temperature and the total power dissipation of the DLPA3000 does not produce an acceptable junction temperature, that is, $<120^{\circ}\text{C}$, there are two approaches:

1. Using larger heat sink or more airflow to reduce $R_{\theta\text{JA}}$
2. Reduce power dissipation in DLPA3000:
 - Use an external buck converter instead of an internal general purpose buck converter.
 - Reduce load current for the buck converter.

The following example shows how to calculate the maximum I_{LED} at 6A when the junction temperature exceeds the maximum allowed temperature.. If it is assumed that $P_{\text{buck_converters}} = 1\text{W}$, $P_{\text{LDOs}} = 0.5\text{W}$, $T_{\text{ambient}} = 75^{\circ}\text{C}$, $R_{\theta\text{JA}} = 7^{\circ}\text{C}/\text{W}$, $V_{\text{LED}} = 3.5\text{V}$ and $T_{\text{junction,max}} = 120^{\circ}\text{C}$, then the total maximum allowed dissipation for the DLPA3000 can be calculated:

$$P_{\text{diss,max}} = \frac{T_{\text{junction,max}} - T_{\text{ambient}}}{R_{\theta\text{JA}}} = \frac{120^{\circ}\text{C} - 75^{\circ}\text{C}}{7^{\circ}\text{C}/\text{W}} = 6.4\text{W} \quad (20)$$

The total dissipation for the buck converters and LDOs is 1.5W, so the maximum dissipation for the illumination block is 4.9W.

The efficiency of the converter can be determined from [Figure 8-13](#). For $V_{\text{LED}} = 3.5\text{V}$ and I_{LED} is between 4 A and 6 A, the average efficiency is about 80%. The typically value of the on resistance of switch P,Q,R is 30 mOhm. Assuming V_{LED} is independent of I_{LED} , the I_{LED} can be calculated using [Equation 13](#):

$$P_{\text{diss_illum}} = V_{\text{LED}} \cdot I_{\text{LED}} \cdot \left(\frac{1}{\eta_{\text{illum_buck}}} - 1 \right) + I_{\text{LED}}^2 \cdot R_{\text{on_sw_PQR}} \quad (21)$$

$$I_{\text{LED}} = \sqrt{\frac{V_{\text{LED}}^2 \left(\frac{1}{\eta_{\text{illum_buck}}} - 1 \right)^2}{4R_{\text{on_sw_PQR}}^2} + \frac{P_{\text{diss_illum}}}{R_{\text{on_sw_PQR}}} - \frac{V_{\text{LED}} \left(\frac{1}{\eta_{\text{illum_buck}}} - 1 \right)}{2R_{\text{on_sw_PQR}}} = 4.8\text{A} \quad (22)$$

12 Device and Documentation Support

12.1 Third-Party Products Disclaimer

TI'S PUBLICATION OF INFORMATION REGARDING THIRD-PARTY PRODUCTS OR SERVICES DOES NOT CONSTITUTE AN ENDORSEMENT REGARDING THE SUITABILITY OF SUCH PRODUCTS OR SERVICES OR A WARRANTY, REPRESENTATION OR ENDORSEMENT OF SUCH PRODUCTS OR SERVICES, EITHER ALONE OR IN COMBINATION WITH ANY TI PRODUCT OR SERVICE.

12.2 Device Support

12.2.1 Device Nomenclature

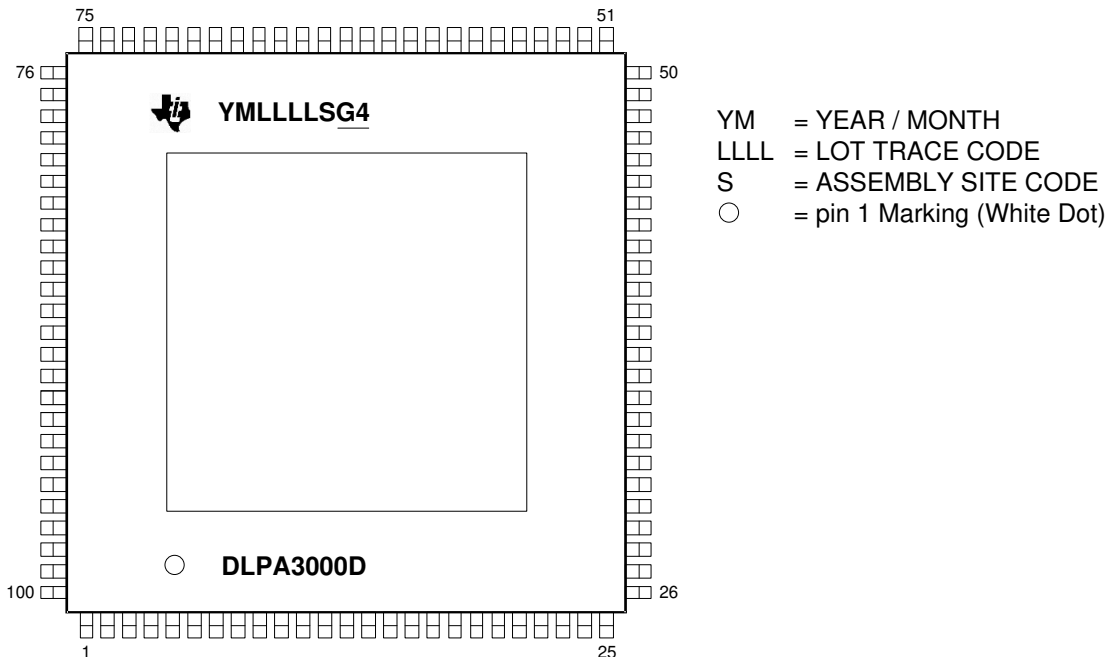

Figure 12-1. Package Marking DLPA3000 (Top View)

12.3 Related Links

The table below lists quick access links. Categories include technical documents, support and community resources, tools and software, and quick access to sample or buy.

Table 12-1. Related Links

PARTS	PRODUCT FOLDER	SAMPLE & BUY	TECHNICAL DOCUMENTS	TOOLS & SOFTWARE	SUPPORT & COMMUNITY
DLPA3000	Click here	Click here	Click here	Click here	Click here
DLPC3433	Click here	Click here	Click here	Click here	Click here
DLPC3438	Click here	Click here	Click here	Click here	Click here

12.4 Receiving Notification of Documentation Updates

To receive notification of documentation updates, navigate to the device product folder on ti.com. Click on *Subscribe to updates* to register and receive a weekly digest of any product information that has changed. For change details, review the revision history included in any revised document.

12.5 Support Resources

[TI E2E™ support forums](#) are an engineer's go-to source for fast, verified answers and design help — straight from the experts. Search existing answers or ask your own question to get the quick design help you need.

Linked content is provided "AS IS" by the respective contributors. They do not constitute TI specifications and do not necessarily reflect TI's views; see TI's [Terms of Use](#).

12.6 Trademarks

Pico™ is a trademark of Texas Instruments.
TI E2E™ is a trademark of Texas Instruments.
DLP® is a registered trademark of Texas Instruments.
is a registered trademark of Texas Instruments.
All trademarks are the property of their respective owners.

12.7 Support Resources

[TI E2E™ support forums](#) are an engineer's go-to source for fast, verified answers and design help — straight from the experts. Search existing answers or ask your own question to get the quick design help you need.

Linked content is provided "AS IS" by the respective contributors. They do not constitute TI specifications and do not necessarily reflect TI's views; see TI's [Terms of Use](#).

12.8 Electrostatic Discharge Caution



This integrated circuit can be damaged by ESD. Texas Instruments recommends that all integrated circuits be handled with appropriate precautions. Failure to observe proper handling and installation procedures can cause damage.

ESD damage can range from subtle performance degradation to complete device failure. Precision integrated circuits may be more susceptible to damage because very small parametric changes could cause the device not to meet its published specifications.

12.9 Glossary

[TI Glossary](#) This glossary lists and explains terms, acronyms, and definitions.

13 Mechanical, Packaging, and Orderable Information

The following pages include mechanical, packaging, and orderable information. This information is the most current data available for the designated devices. This data is subject to change without notice and revision of this document. For browser-based versions of this data sheet, refer to the left-hand navigation.

PACKAGING INFORMATION

Orderable Device	Status (1)	Package Type	Package Drawing	Pins	Package Qty	Eco Plan (2)	Lead finish/ Ball material (6)	MSL Peak Temp (3)	Op Temp (°C)	Device Marking (4/5)	Samples
DLPA3000DPFD	ACTIVE	HTQFP	PFD	100	90	RoHS & Green	NIPDAU	Level-2-260C-1 YEAR	0 to 70	DLPA3000D	Samples
DLPA3000DPFDR	ACTIVE	HTQFP	PFD	100	1000	RoHS & Green	NIPDAU	Level-2-260C-1 YEAR	0 to 70	DLPA3000D	Samples

(1) The marketing status values are defined as follows:

ACTIVE: Product device recommended for new designs.

LIFEBUY: TI has announced that the device will be discontinued, and a lifetime-buy period is in effect.

NRND: Not recommended for new designs. Device is in production to support existing customers, but TI does not recommend using this part in a new design.

PREVIEW: Device has been announced but is not in production. Samples may or may not be available.

OBsolete: TI has discontinued the production of the device.

(2) **RoHS:** TI defines "RoHS" to mean semiconductor products that are compliant with the current EU RoHS requirements for all 10 RoHS substances, including the requirement that RoHS substance do not exceed 0.1% by weight in homogeneous materials. Where designed to be soldered at high temperatures, "RoHS" products are suitable for use in specified lead-free processes. TI may reference these types of products as "Pb-Free".

RoHS Exempt: TI defines "RoHS Exempt" to mean products that contain lead but are compliant with EU RoHS pursuant to a specific EU RoHS exemption.

Green: TI defines "Green" to mean the content of Chlorine (Cl) and Bromine (Br) based flame retardants meet JS709B low halogen requirements of <=1000ppm threshold. Antimony trioxide based flame retardants must also meet the <=1000ppm threshold requirement.

(3) MSL, Peak Temp. - The Moisture Sensitivity Level rating according to the JEDEC industry standard classifications, and peak solder temperature.

(4) There may be additional marking, which relates to the logo, the lot trace code information, or the environmental category on the device.

(5) Multiple Device Markings will be inside parentheses. Only one Device Marking contained in parentheses and separated by a "~" will appear on a device. If a line is indented then it is a continuation of the previous line and the two combined represent the entire Device Marking for that device.

(6) Lead finish/Ball material - Orderable Devices may have multiple material finish options. Finish options are separated by a vertical ruled line. Lead finish/Ball material values may wrap to two lines if the finish value exceeds the maximum column width.

Important Information and Disclaimer:The information provided on this page represents TI's knowledge and belief as of the date that it is provided. TI bases its knowledge and belief on information provided by third parties, and makes no representation or warranty as to the accuracy of such information. Efforts are underway to better integrate information from third parties. TI has taken and continues to take reasonable steps to provide representative and accurate information but may not have conducted destructive testing or chemical analysis on incoming materials and chemicals. TI and TI suppliers consider certain information to be proprietary, and thus CAS numbers and other limited information may not be available for release.

In no event shall TI's liability arising out of such information exceed the total purchase price of the TI part(s) at issue in this document sold by TI to Customer on an annual basis.

THERMAL PAD MECHANICAL DATA

PFD (S-PQFP-G100)

PowerPAD™ PLASTIC QUAD FLATPACK

THERMAL INFORMATION

This PowerPAD™ package incorporates an exposed thermal pad that is designed to be attached directly to an external heatsink. This design optimizes the heat transfer from the integrated circuit (IC).

For additional information on the PowerPAD package and how to take advantage of its heat dissipating abilities, refer to Technical Brief, PowerPAD Thermally Enhanced Package, Texas Instruments Literature No. SLMA002 and Application Brief, PowerPAD Made Easy, Texas Instruments Literature No. SLMA004. Both documents are available at www.ti.com.

The exposed thermal pad dimensions for this package are shown in the following illustration.

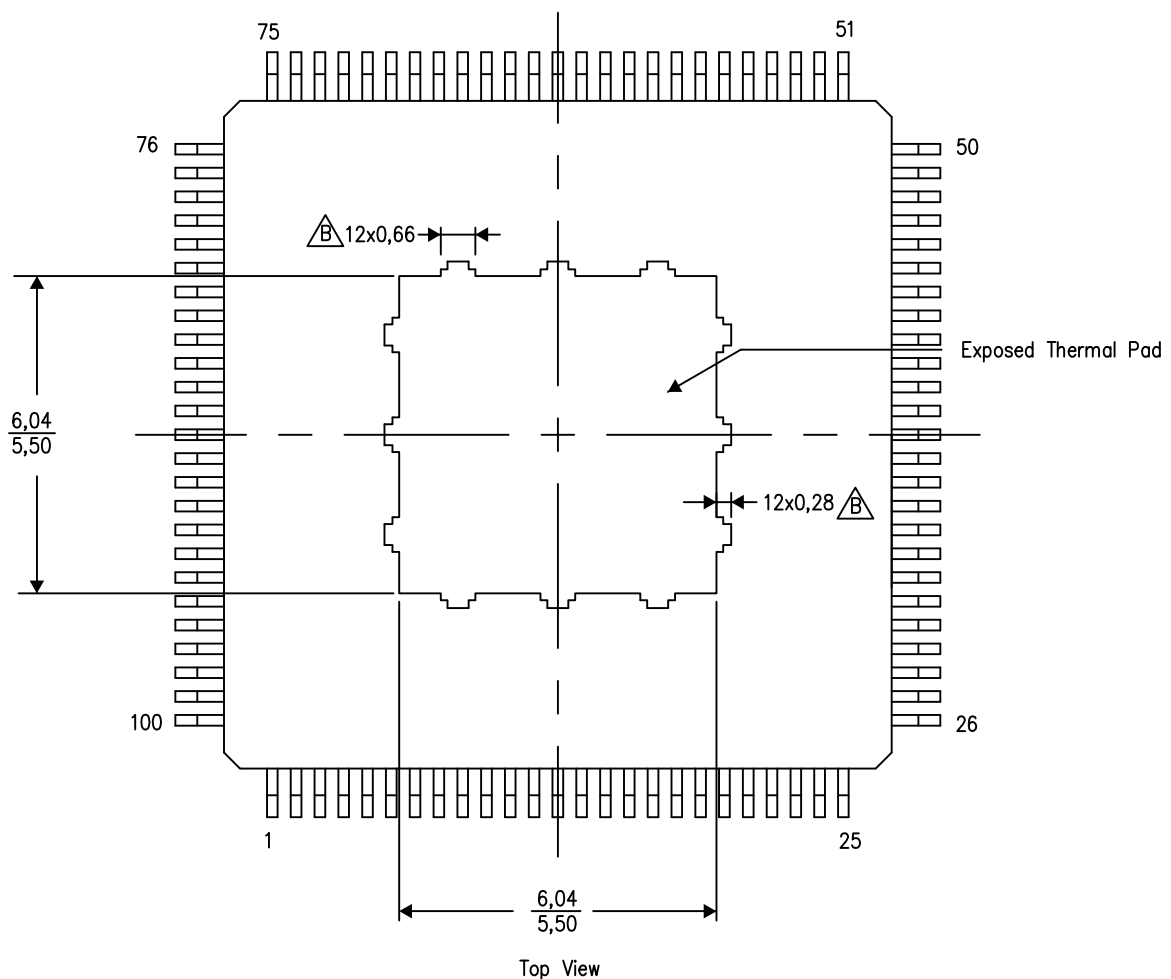

4211595-3/B 06/14

NOTE: A. All linear dimensions are in millimeters

 Tie strap features may not be present.

PowerPAD is a trademark of Texas Instruments

PFD (S-PQFP-G100)

PowerPAD™ PLASTIC QUAD FLATPACK

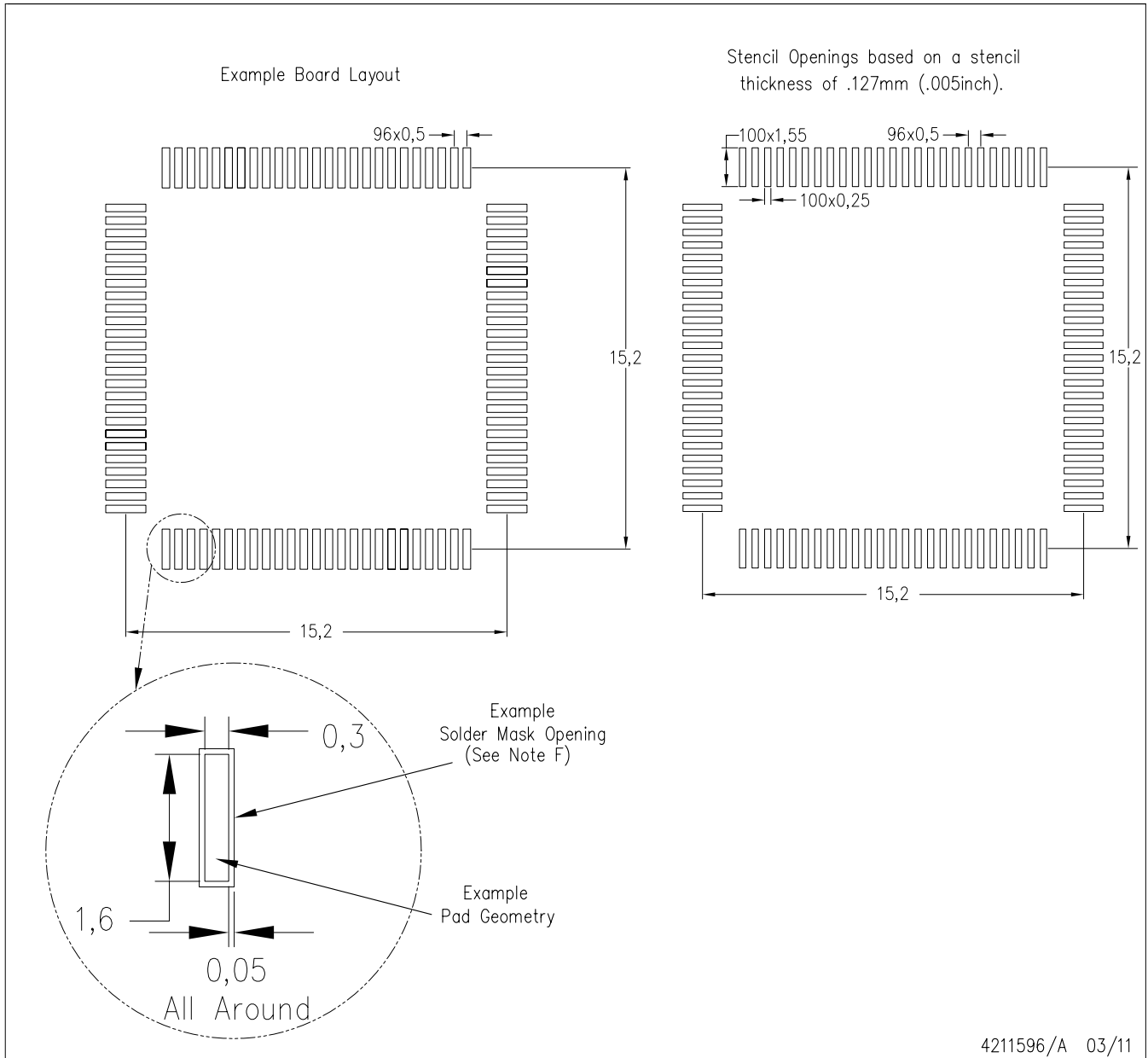

- NOTES:
- A. All linear dimensions are in millimeters.
 - B. This drawing is subject to change without notice.
 - C. Laser cutting apertures with trapezoidal walls and also rounding corners will offer better paste release. Customers should contact their board assembly site for stencil design recommendations. Example stencil design based on a 50% volumetric metal load solder paste. Refer to IPC-7525 for other stencil recommendations.
 - D. Customers should contact their board fabrication site for solder mask tolerances between and around signal pads.

IMPORTANT NOTICE AND DISCLAIMER

TI PROVIDES TECHNICAL AND RELIABILITY DATA (INCLUDING DATA SHEETS), DESIGN RESOURCES (INCLUDING REFERENCE DESIGNS), APPLICATION OR OTHER DESIGN ADVICE, WEB TOOLS, SAFETY INFORMATION, AND OTHER RESOURCES "AS IS" AND WITH ALL FAULTS, AND DISCLAIMS ALL WARRANTIES, EXPRESS AND IMPLIED, INCLUDING WITHOUT LIMITATION ANY IMPLIED WARRANTIES OF MERCHANTABILITY, FITNESS FOR A PARTICULAR PURPOSE OR NON-INFRINGEMENT OF THIRD PARTY INTELLECTUAL PROPERTY RIGHTS.

These resources are intended for skilled developers designing with TI products. You are solely responsible for (1) selecting the appropriate TI products for your application, (2) designing, validating and testing your application, and (3) ensuring your application meets applicable standards, and any other safety, security, regulatory or other requirements.

These resources are subject to change without notice. TI grants you permission to use these resources only for development of an application that uses the TI products described in the resource. Other reproduction and display of these resources is prohibited. No license is granted to any other TI intellectual property right or to any third party intellectual property right. TI disclaims responsibility for, and you will fully indemnify TI and its representatives against, any claims, damages, costs, losses, and liabilities arising out of your use of these resources.

TI's products are provided subject to [TI's Terms of Sale](#) or other applicable terms available either on [ti.com](https://www.ti.com) or provided in conjunction with such TI products. TI's provision of these resources does not expand or otherwise alter TI's applicable warranties or warranty disclaimers for TI products.

TI objects to and rejects any additional or different terms you may have proposed.

Mailing Address: Texas Instruments, Post Office Box 655303, Dallas, Texas 75265
Copyright © 2023, Texas Instruments Incorporated

Looking for pricing, stock, or lifecycle information?

Click below to explore more details on WIN SOURCE:

 [View DLPA3000DPFDR on WIN SOURCE](#)

 [Texas Instruments](#) Information

Optimize Your Supply Chain with WIN SOURCE Solutions

-  Global Sourcing Solution
-  Obsolete Management
-  Cost Control Management
-  Shortage Management
-  Alternative Solution
-  Excess Inventory Management