



**THE DATASHEET OF
FM28V020-TG**



256-Kbit (32K × 8) F-RAM Memory

Features

- 256-Kbit ferroelectric random access memory (F-RAM) logically organized as 32K × 8
 - High-endurance 100 trillion (10^{14}) read/writes
 - 151-year data retention (see [Data Retention and Endurance on page 8](#))
 - NoDelay™ writes
 - Page mode operation
 - Advanced high-reliability ferroelectric process
- SRAM compatible
 - Industry-standard 32K × 8 SRAM pinout
 - 70-ns access time, 140-ns cycle time
- Superior to battery-backed SRAM modules
 - No battery concerns
 - Monolithic reliability
 - True surface mount solution, no rework steps
 - Superior for moisture, shock, and vibration
 - Resistant to negative voltage undershoots
- Low power consumption
 - Active current 5 mA (typ)
 - Standby current 90 μA (typ)
- Low-voltage operation: $V_{DD} = 2.0\text{ V to }3.6\text{ V}$
- Industrial temperature: $-40\text{ °C to }+85\text{ °C}$

- Packages:
 - 28-pin small outline integrated circuit (SOIC) package
 - 28-pin thin small outline package (TSOP) Type I
 - 32-pin thin small outline package (TSOP) Type I
- Restriction of hazardous substances (RoHS) compliant

Functional Description

The FM28V020 is a 32K × 8 nonvolatile memory that reads and writes similar to a standard SRAM. A ferroelectric random access memory or F-RAM is nonvolatile, which means that data is retained after power is removed. It provides data retention for over 151 years while eliminating the reliability concerns, functional disadvantages, and system design complexities of battery-backed SRAM (BBSRAM). Fast write timing and high write endurance make the F-RAM superior to other types of memory.

The FM28V020 operation is similar to that of other RAM devices and therefore, it can be used as a drop-in replacement for a standard SRAM in a system. Read and write cycles may be triggered by CE or simply by changing the address. The F-RAM memory is nonvolatile due to its unique ferroelectric memory process. These features make the FM28V020 ideal for nonvolatile memory applications requiring frequent or rapid writes.

The device is available in a 28-pin SOIC, 28-pin TSOP I and 32-pin TSOP I surface mount packages. Device specifications are guaranteed over the industrial temperature range $-40\text{ °C to }+85\text{ °C}$.

For a complete list of related documentation, click [here](#).

Logic Block Diagram

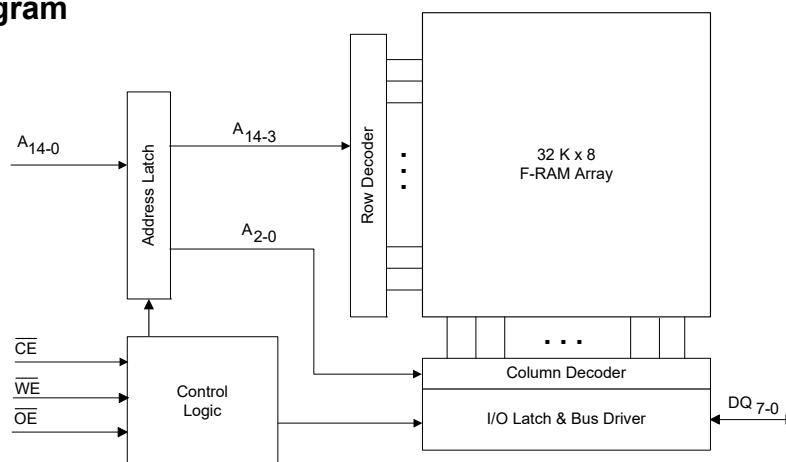

Contents

Pinouts	3	SRAM Write Cycle	10
Pin Definitions	4	Power Cycle Timing	13
Device Operation	5	Functional Truth Table	14
Memory Operation	5	Ordering Information	15
Read Operation	5	Ordering Code Definitions	15
Write Operation	5	Package Diagrams	16
Page Mode Operation	5	Acronyms	19
Pre-charge Operation	5	Document Conventions	19
SRAM Drop-In Replacement	6	Units of Measure	19
Endurance	6	Document History Page	20
Maximum Ratings	7	Sales, Solutions, and Legal Information	22
Operating Range	7	Worldwide Sales and Design Support	22
DC Electrical Characteristics	7	Products	22
Data Retention and Endurance	8	PSoC® Solutions	22
Capacitance	8	Cypress Developer Community	22
Thermal Resistance	8	Technical Support	22
AC Test Conditions	8		
AC Switching Characteristics	9		
SRAM Read Cycle	9		

Pinouts

Figure 1. 28-pin SOIC pinout

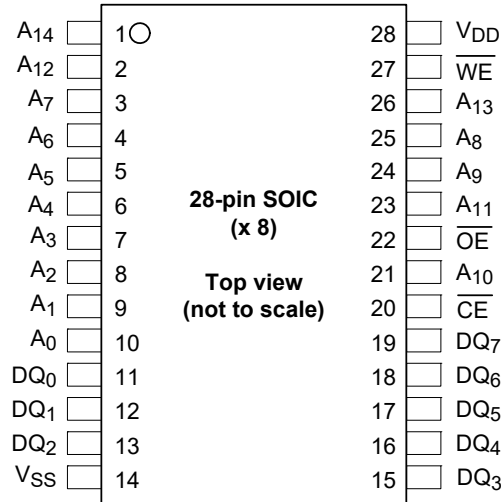

Figure 2. 28-pin TSOP I pinout

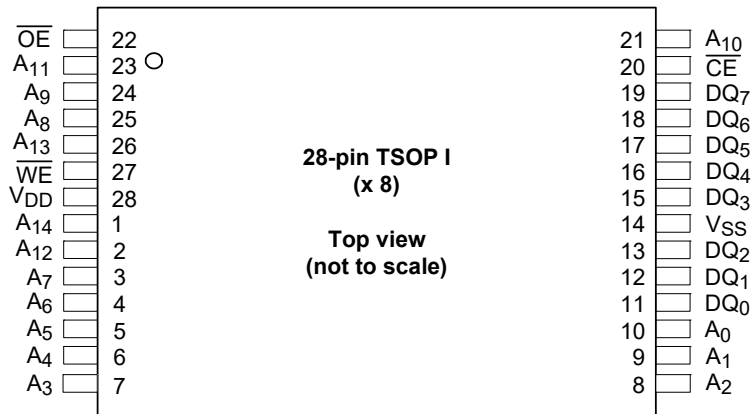
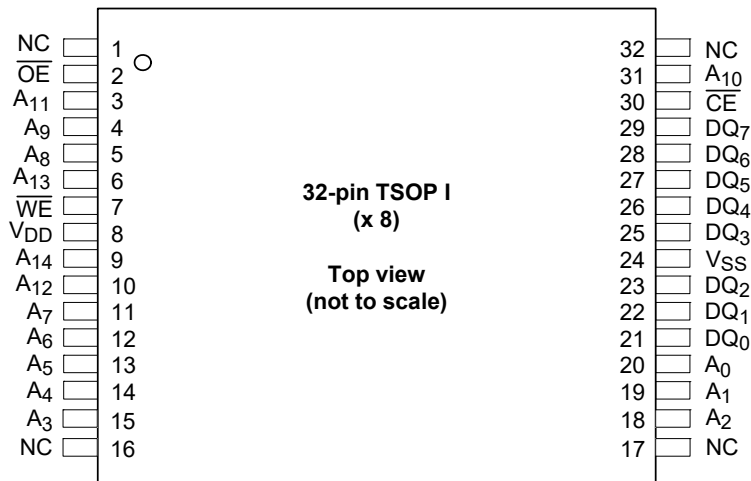

Figure 3. 32-pin TSOP I pinout



Pin Definitions

Pin Name	I/O Type	Description
$A_{14}-A_0$	Input	Address inputs: The 15 address lines select one of 32,768 bytes in the F-RAM array. The lowest two address lines A_2-A_0 may be used for page mode read and write operations.
DQ_7-DQ_0	Input/Output	Data I/O Lines: 8-bit bidirectional data bus for accessing the F-RAM array.
\overline{WE}	Input	Write Enable: A write cycle begins when \overline{WE} is asserted. The rising edge causes the FM28V020 to write the data on the DQ bus to the F-RAM array. The falling edge of \overline{WE} latches a new column address for page mode write cycles.
\overline{CE}	Input	Chip Enable: The device is selected and a new memory access begins on the falling edge of \overline{CE} . The entire address is latched internally at this point. Subsequent changes to the A_2-A_0 address inputs allow page mode operation.
\overline{OE}	Input	Output Enable: When \overline{OE} is LOW, the FM28V020 drives the data bus when the valid read data is available. Deasserting \overline{OE} HIGH tristates the DQ pins.
V_{SS}	Ground	Ground for the device. Must be connected to the ground of the system.
V_{DD}	Power supply	Power supply input to the device.
NC	No connect	No connect. This pin is not connected to the die.

Device Operation

The FM28V020 is a byte-wide F-RAM memory logically organized as 32,768 × 8 and accessed using an industry-standard parallel interface. All data written to the part is immediately nonvolatile with no delay. The device offers page mode operation, which provides high-speed access to addresses within a page (row). Access to a different page requires that either \overline{CE} transitions LOW or the upper address (A_{14} – A_3) changes. See the [Functional Truth Table on page 14](#) for a complete description of read and write modes.

Memory Operation

Users access 32,768 memory locations, each with 8 data bits through a parallel interface. The F-RAM array is organized as eight blocks, each having 512 rows. Each row has eight column locations, which allow fast access in page mode operation. When an initial address is latched by the falling edge of \overline{CE} , subsequent column locations may be accessed without the need to toggle \overline{CE} . When \overline{CE} is deasserted HIGH, a pre-charge operation begins. Writes occur immediately at the end of the access with no delay. The \overline{WE} pin must be toggled for each write operation. The write data is stored in the nonvolatile memory array immediately, which is a feature unique to F-RAM called NoDelay writes.

Read Operation

A read operation begins on the falling edge of \overline{CE} . The falling edge of \overline{CE} causes the address to be latched and starts a memory read cycle if \overline{WE} is HIGH. Data becomes available on the bus after the access time is met. When the address is latched and the access completed, a new access to a random location (different row) may begin while \overline{CE} is still LOW. The minimum cycle time for random addresses is t_{RC} . Note that unlike SRAMs, the FM28V020's \overline{CE} -initiated access time is faster than the address access time.

The FM28V020 will drive the data bus when \overline{OE} is asserted LOW and the memory access time is met. If \overline{OE} is asserted after the memory access time is met, the data bus will be driven with valid data. If \overline{OE} is asserted before completing the memory access, the data bus will not be driven until valid data is available. This feature minimizes supply current in the system by eliminating transients caused by invalid data being driven to the bus. When \overline{OE} is deasserted HIGH, the data bus will remain in a HI-Z state.

Write Operation

In the FM28V020, writes occur in the same interval as reads. The FM28V020 supports both \overline{CE} and \overline{WE} controlled write cycles. In both cases, the address is latched on the falling edge of \overline{CE} .

In a \overline{CE} -controlled write, the \overline{WE} signal is asserted before beginning the memory cycle. That is, \overline{WE} is LOW when the device is activated with the chip enable. In this case, the device begins the memory cycle as a write. The FM28V020 will not drive the data bus regardless of the state of \overline{OE} as long as \overline{WE} is LOW.

Input data must be valid when \overline{CE} is deasserted HIGH. In a \overline{WE} -controlled write, the memory cycle begins on the falling edge of \overline{CE} . The \overline{WE} signal falls some time later. Therefore, the memory cycle begins as a read. The data bus will be driven if \overline{OE} is LOW; however, it will be HI-Z when \overline{WE} is asserted LOW. The \overline{CE} and \overline{WE} controlled write timing cases are shown on the [Figure 9 on page 12](#). In [Figure 10 on page 12](#), the data bus is shown as a hi-Z condition while the chip is write-enabled and before the required setup time. Although this is drawn to look like a mid-level voltage, it is recommended that all DQ pins comply with the minimum V_{IH}/V_{IL} operating levels.

Write access to the array begins on the falling edge of \overline{WE} after the memory cycle is initiated. The write access terminates on the rising edge of \overline{WE} or \overline{CE} , whichever comes first. A valid write operation requires the user to meet the access time specification before deasserting \overline{WE} or \overline{CE} . The data setup time indicates the interval during which data cannot change before the end of the write access (rising edge of \overline{WE} or \overline{CE}).

Unlike other nonvolatile memory technologies, there is no write delay with F-RAM. Because the read and write access times of the underlying memory are the same, the user experiences no delay through the bus. The entire memory operation occurs in a single bus cycle. Data polling, a technique used with EEPROMs to determine if a write is complete, is unnecessary.

Page Mode Operation

The FM28V020 provides the user fast access to any data within a row element. Each row has eight column-address locations. Address inputs A_2 – A_0 define the column address to be accessed. An access can start anywhere within a row and other column locations may be accessed without the need to toggle the \overline{CE} pin. For fast access reads, after the first data byte is driven to the bus, the column address inputs A_2 – A_0 may be changed to a new value. A new data byte is then driven to the DQ pins. For fast access writes, the first write pulse defines the first write access. While \overline{CE} is LOW, a subsequent write pulse along with a new column address provides a page mode write access.

Pre-charge Operation

The pre-charge operation is an internal condition in which the memory state is prepared for a new access. Pre-charge is user-initiated by driving the \overline{CE} signal HIGH. It must remain HIGH for at least the minimum pre-charge time, t_{PC} .

Pre-charge is also activated by changing the upper addresses, A_{14} – A_3 . The current row is first closed before accessing the new row. The device automatically detects an upper order address change, which starts a pre-charge operation. The new address is latched and the new read data is valid within the t_{AA} address access time; see [Figure 6 on page 11](#). A similar sequence occurs for write cycles; see [Figure 11 on page 12](#). The rate at which random addresses can be issued is t_{RC} and t_{WC} , respectively.

SRAM Drop-In Replacement

The FM28V020 is designed to be a drop-in replacement for standard asynchronous SRAMs. The device does not require \overline{CE} to toggle for each new address. \overline{CE} may remain LOW indefinitely while V_{DD} is applied. While \overline{CE} is LOW, the device automatically detects address changes and a new access begins. It also allows page mode operation at speeds up to 15 MHz.

A typical application is shown in Figure 4. It shows a pull-up resistor on \overline{CE} , which will keep the pin HIGH during power cycles, assuming the MCU / MPU pin tristates during the reset condition. The pull-up resistor value should be chosen to ensure the \overline{CE} pin tracks V_{DD} to a high enough value, so that the current drawn when \overline{CE} is LOW is not an issue. A 10-k Ω resistor draws 330 μ A when \overline{CE} is LOW and $V_{DD} = 3.3$ V.

Figure 4. Use of Pull-up Resistor on \overline{CE}

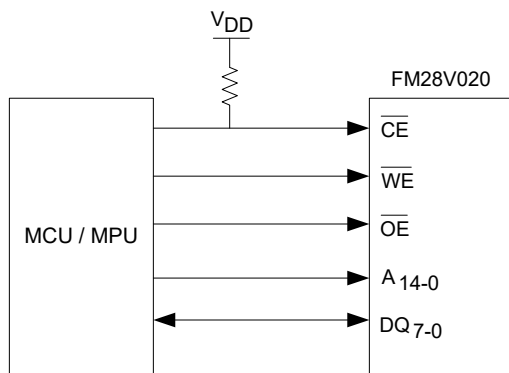

Note that if \overline{CE} is tied to ground, the user must be sure \overline{WE} is not LOW at power-up or power-down events. If \overline{CE} and \overline{WE} are both LOW during power cycles, data will be corrupted. Figure 5 shows a pull-up resistor on \overline{WE} , which will keep the pin HIGH during power cycles, assuming the MCU/MPU pin tristates during the reset condition. The pull-up resistor value should be chosen to ensure the \overline{WE} pin tracks V_{DD} to a high enough value, so that the current drawn when \overline{WE} is LOW is not an issue. A 10-k Ω resistor draws 330 μ A when \overline{WE} is LOW and $V_{DD} = 3.3$ V.

Figure 5. Use of Pull-up Resistor on \overline{WE}

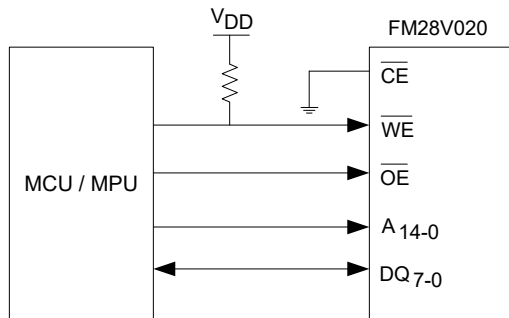

For applications that require the lowest power consumption, the \overline{CE} signal should be active only during memory accesses. Due to the external pull-up resistor, some supply current will be drawn while \overline{CE} is LOW. When \overline{CE} is HIGH, the device draws no more than the maximum standby current I_{SB} .

\overline{CE} toggling LOW on every address access is perfectly acceptable in FM28V020.

Endurance

The FM28V020 is capable of being accessed at least 10^{14} times – reads or writes. An F-RAM memory operates with a read and restore mechanism. Therefore, an endurance cycle is applied on a row basis. The F-RAM architecture is based on an array of rows and columns. Rows are defined by A_{14-3} and column addresses by A_2-A_0 . The array is organized as 4K rows of eight bytes each. The entire row is internally accessed once whether a single byte or all eight bytes are read or written. Each byte in the row is counted only once in an endurance calculation if the addressing is contiguous in nature.

The user may choose to write CPU instructions and run them from a certain address space. Table 1 shows endurance calculations for a 256-byte repeating loop, which includes a starting address, seven-page mode accesses, and a \overline{CE} pre-charge. The number of bus clock cycles needed to complete a eight-byte read transaction is 1 + 7 + 1 or 9 clocks. The entire loop causes each byte to experience only one endurance cycle. The F-RAM read and write endurance is virtually unlimited.

Table 1. Time to Reach 100 Trillion Cycles for Repeating 256-byte Loop

Bus Freq (MHz)	Bus Cycle Time (ns)	256-byte Transaction Time (μ s)	Endurance Cycles/sec	Endurance Cycles/yr	Years to Reach 10^{14} Cycles
10	100	28.8	34,720	1.09×10^{12}	91.7
5	200	57.6	17,360	5.47×10^{11}	182.8

Maximum Ratings

Exceeding maximum ratings may shorten the useful life of the device. These user guidelines are not tested.

Storage temperature	-65 °C to +125 °C
Maximum accumulated storage time	
At 125 °C ambient temperature	1000 h
At 85 °C ambient temperature	10 Years
Ambient temperature	
with power applied	-55 °C to +125 °C
Supply voltage on V_{DD} relative to V_{SS}	-1.0 V to + 4.5 V
Voltage applied to outputs	
in High Z state	-0.5 V to $V_{DD} + 0.5$ V
Input voltage	-1.0 V to + 4.5 V and $V_{IN} < V_{DD} + 1.0$ V
Transient voltage (< 20 ns)	
on any pin to ground potential	-2.0 V to $V_{CC} + 2.0$ V

Package power dissipation capability	
($T_A = 25$ °C)	1.0 W
Surface mount Pb soldering temperature	
(3 seconds)	+260 °C
DC output current	
(1 output at a time, 1s duration)	15 mA
Static discharge voltage	
Human Body Model (AEC-Q100-002 Rev. E)	2 kV
Charged Device Model (AEC-Q100-011 Rev. B) ..	1.25 kV
Machine Model (AEC-Q100-003 Rev. E)	200 V
Latch-up current	> 140 mA

Operating Range

Range	Ambient Temperature (T_A)	V_{DD}
Industrial	-40 °C to +85 °C	2.0 V to 3.6 V

DC Electrical Characteristics

Over the [Operating Range](#)

Parameter	Description	Test Conditions	Min	Typ ^[1]	Max	Unit
V_{DD}	Power supply voltage		2.0	3.3	3.6	V
I_{DD}	V_{DD} supply current	$V_{DD} = 3.6$ V, \overline{CE} cycling at min. cycle time. All inputs toggling at CMOS levels (0.2 V or $V_{DD} - 0.2$ V), all DQ pins unloaded.	-	5	8	mA
I_{SB}	Standby current	$V_{DD} = 3.6$ V, \overline{CE} at V_{DD} . All other pins are static and at CMOS levels (0.2 V or $V_{DD} - 0.2$ V)	-	90	150	μ A
I_{LI}	Input leakage current	V_{IN} between V_{DD} and V_{SS}	-	-	± 1	μ A
I_{LO}	Output leakage current	V_{OUT} between V_{DD} and V_{SS}	-	-	± 1	μ A
V_{IH}	Input HIGH voltage		$0.7 \times V_{DD}$	-	$V_{DD} + 0.3$	V
V_{IL}	Input LOW voltage		-0.3	-	$0.3 \times V_{DD}$	V
V_{OH1}	Output HIGH voltage	$I_{OH} = -1.0$ mA, $V_{DD} > 2.7$ V	2.4	-	-	V
V_{OH2}	Output HIGH voltage	$I_{OH} = -100$ μ A	$V_{DD} - 0.2$	-	-	V
V_{OL1}	Output LOW voltage	$I_{OL} = 1$ mA, $V_{DD} > 2.7$ V	-	-	0.4	V
V_{OL2}	Output LOW voltage	$I_{OL} = 150$ μ A	-	-	0.2	V

Note

1. Typical values are at 25 °C, $V_{DD} = V_{DD}(typ)$. Not 100% tested.

Data Retention and Endurance

Parameter	Description	Test condition	Min	Max	Unit
T _{DR}	Data retention	At +85 °C	10	–	Years
		At +75 °C	38	–	
		At +65 °C	151	–	
NV _C	Endurance	Over operating temperature	10 ¹⁴	–	Cycles

Capacitance

Parameter	Description	Test Conditions	Max	Unit
C _{I/O}	Input/Output capacitance (DQ)	T _A = 25 °C, f = 1 MHz, V _{DD} = V _{DD} (Typ)	8	pF
C _{IN}	Input capacitance		6	pF

Thermal Resistance

Parameter	Description	Test Conditions	28-pin SOIC	28-pin TSOP I	32-pin TSOP I	Unit
Θ _{JA}	Thermal resistance (junction to ambient)	Test conditions follow standard test methods and procedures for measuring thermal impedance, in accordance with EIA/JESD51.	59	108	84	°C/W
Θ _{JC}	Thermal resistance (junction to case)		30	29	26	°C/W

AC Test Conditions

Input pulse levels 0 V to 3 V
 Input rise and fall times (10%–90%) ≤ 3 ns
 Input and output timing reference levels 1.5 V
 Output load capacitance 30 pF

AC Switching Characteristics

Over the [Operating Range](#)

Parameters ^[2]		Description	Min	Max	Unit
Cypress Parameter	Alt Parameter				
SRAM Read Cycle					
t _{CE}	t _{ACE}	Chip enable access time	–	70	ns
t _{RC}	–	Read cycle time	140	–	ns
t _{AA}	–	Address access time	–	140	ns
t _{OH}	t _{OHA}	Output hold time	20	–	ns
t _{AAP}	–	Page mode address access time	–	40	ns
t _{OHP}	–	Page mode output hold time	3	–	ns
t _{CA}	–	Chip enable active time	70	–	ns
t _{PC}	–	Pre-charge time	70	–	ns
t _{AS}	t _{SA}	Address setup time (to \overline{CE} LOW)	0	–	ns
t _{AH}	t _{HA}	Address hold time (\overline{CE} Controlled)	70	–	ns
t _{OE} ^[3]	t _{DOE}	Output enable access time	–	20	ns
t _{HZ} ^[4, 5]	t _{HZCE}	Chip Enable to output HI-Z	–	10	ns
t _{OHZ} ^[4, 5]	t _{HZOE}	Output enable HIGH to output HI-Z	–	10	ns

Notes

- Test conditions assume a signal transition time of 3 ns or less, timing reference levels of $0.5 \times V_{DD}$, input pulse levels of 0 to 3 V, output loading of the specified I_{OL}/I_{OH} and load capacitance shown in [AC Test Conditions on page 8](#).
- For $V_{DD} < 2.7$ V, t_{OE} max is 25 ns.
- t_{HZ} and t_{OHZ} are specified with a load capacitance of 5 pF. Transition is measured when the outputs enter a high impedance state.
- This parameter is characterized but not 100% tested.

AC Switching Characteristics (continued)

Over the [Operating Range](#)

Parameters ^[2]		Description	Min	Max	Unit
Cypress Parameter	Alt Parameter				
SRAM Write Cycle					
t_{WC}	t_{WC}	Write cycle time	140	–	ns
t_{CA}	–	Chip enable active time	70	–	ns
t_{CW}	t_{SCE}	Chip enable to write enable HIGH	70	–	ns
t_{PC}	–	Pre-charge time	70	–	ns
t_{PWC}	–	Page mode write enable cycle time	35	–	ns
t_{WP}	t_{PWE}	Write enable pulse width	18	–	ns
t_{AS}	t_{SA}	Address setup time (to \overline{CE} LOW)	0	–	ns
t_{AH}	t_{HA}	Address hold time (\overline{CE} Controlled)	70	–	ns
t_{ASP}	–	Page mode address setup time (to \overline{WE} LOW)	5	–	ns
t_{AHP}	–	Page mode address hold time (to \overline{WE} LOW)	20	–	ns
t_{WLC}	t_{PWE}	Write enable LOW to chip disabled	25	–	ns
t_{WLA}	–	Write enable LOW to A_{14-3} change	25	–	ns
t_{AWH}	–	A_{14-3} change to write enable HIGH	140	–	ns
t_{DS}	t_{SD}	Data input setup time	15	–	ns
t_{DH}	t_{HD}	Data input hold time	0	–	ns
$t_{WZ}^{[6, 7]}$	t_{HZWE}	Write enable LOW to output HI-Z	–	10	ns
$t_{WX}^{[7]}$	–	Write enable HIGH to output driven	5	–	ns
$t_{WS}^{[7, 8]}$	–	Write enable to \overline{CE} LOW setup time	0	–	ns
$t_{WH}^{[7, 8]}$	–	Write enable to \overline{CE} HIGH hold time	0	–	ns

Notes

6. t_{WZ} is specified with a load capacitance of 5 pF. Transition is measured when the outputs enter a high impedance state.
7. This parameter is characterized but not 100% tested.
8. The relationship between \overline{CE} and \overline{WE} determines if a \overline{CE} or \overline{WE} controlled write occurs.

Figure 6. Read Cycle Timing 1 (\overline{CE} LOW, \overline{OE} LOW)

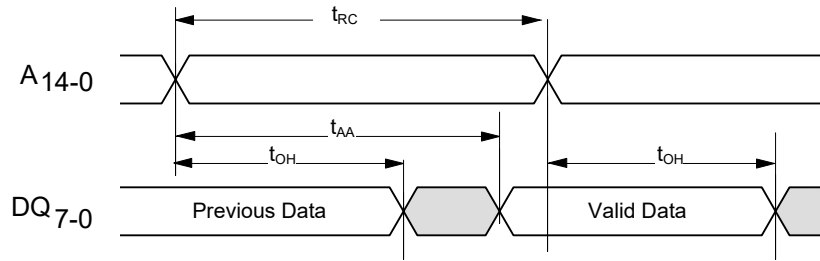

Figure 7. Read Cycle Timing 2 (\overline{CE} Controlled)

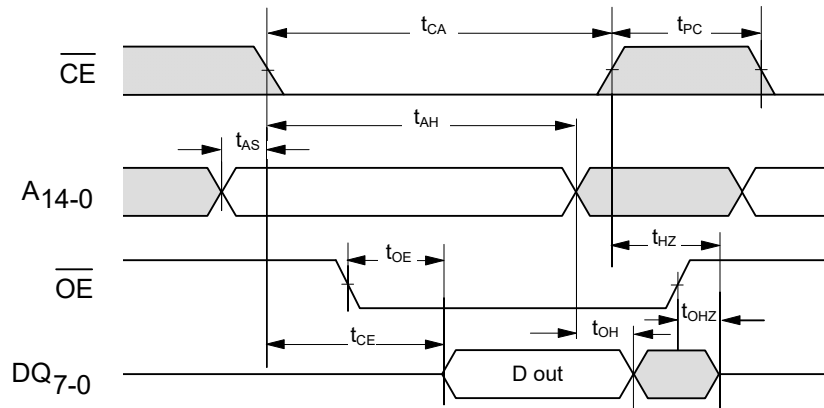
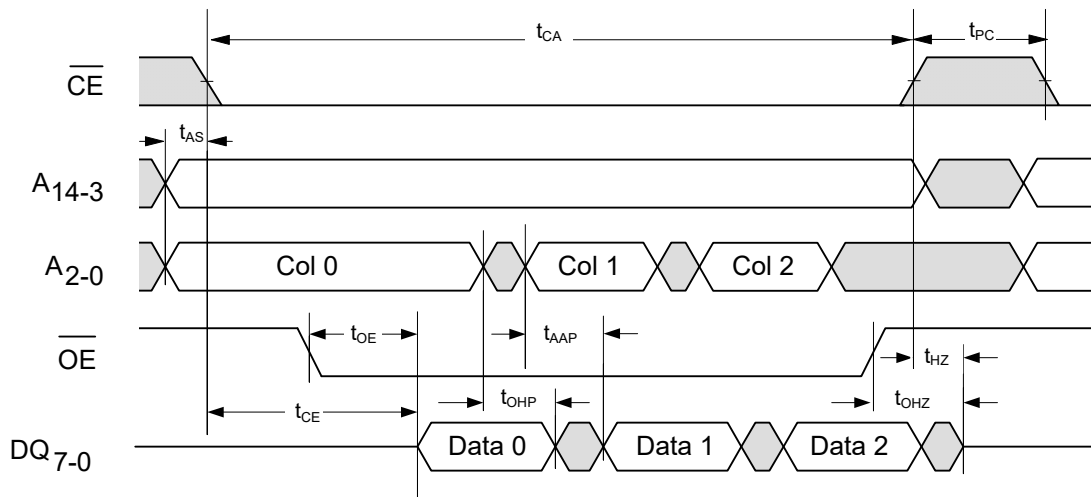

Figure 8. Page Mode Read Cycle Timing ^[9]



Note

9. Although sequential column addressing is shown, it is not required.

Figure 12. Page Mode Write Cycle Timing

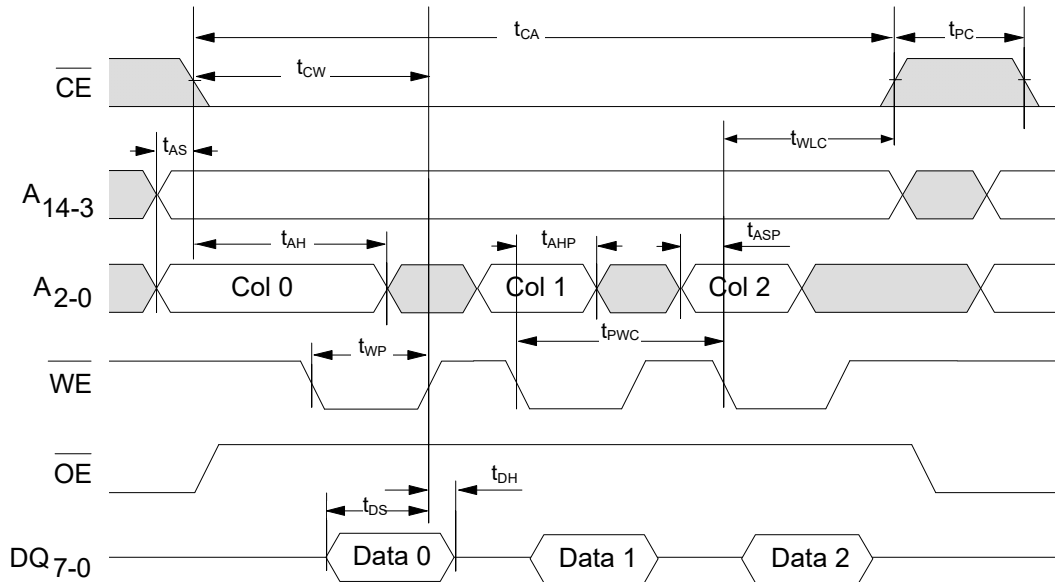

Power Cycle Timing

Over the [Operating Range](#)

Parameter	Description	Min	Max	Unit
t_{PU}	Power-up (after V_{DD} min. is reached) to first access time	250	–	μs
t_{PD}	Last write (\overline{WE} HIGH) to power down time	0	–	μs
$t_{VR}^{[11]}$	V_{DD} power-up ramp rate	50	–	$\mu s/V$
$t_{VF}^{[11]}$	V_{DD} power-down ramp rate	100	–	$\mu s/V$

Figure 13. Power Cycle Timing

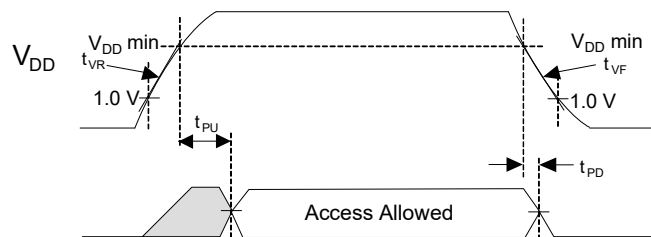

Note

11. Slope measured at any point on the V_{DD} waveform.

Functional Truth Table

\overline{CE}	\overline{WE}	$A_{14}-A_3$	A_2-A_0	Operation ^[12, 13]
H	X	X	X	Standby/Idle
↓ L	H H	V V	V V	Read
L	H	No Change	Change	Page Mode Read
L	H	Change	V	Random Read
↓ L	L L	V V	V V	\overline{CE} -Controlled Write ^[13]
L	↓	V	V	\overline{WE} -Controlled Write ^[13, 14]
L	↓	No Change	V	Page Mode Write ^[15]
↑ L	X X	X X	X X	Starts pre-charge

Notes

12. H = Logic HIGH, L = Logic LOW, V = Valid Data, X = Don't Care, ↓ = toggle LOW, ↑ = toggle HIGH.
 13. For write cycles, data-in is latched on the rising edge of \overline{CE} or \overline{WE} , whichever comes first.
 14. \overline{WE} -controlled write cycle begins as a Read cycle and then $A_{14}-A_3$ is latched.
 15. Addresses A_2-A_0 must remain stable for at least 15 ns during page mode operation.

Ordering Information

Access time (ns)	Ordering Code	Package Diagram	Package Type	Operating Range
70	FM28V020-SG	51-85026	28-pin SOIC	Industrial
	FM28V020-SGTR	51-85026	28-pin SOIC	
	FM28V020-T28G	001-91155	28-pin TSOP I	
	FM28V020-T28GTR	001-91155	28-pin TSOP I	
	FM28V020-TG	001-91156	32-pin TSOP I	
	FM28V020-TGTR	001-91156	32-pin TSOP I	

All the above parts are Pb-free.

Ordering Code Definitions

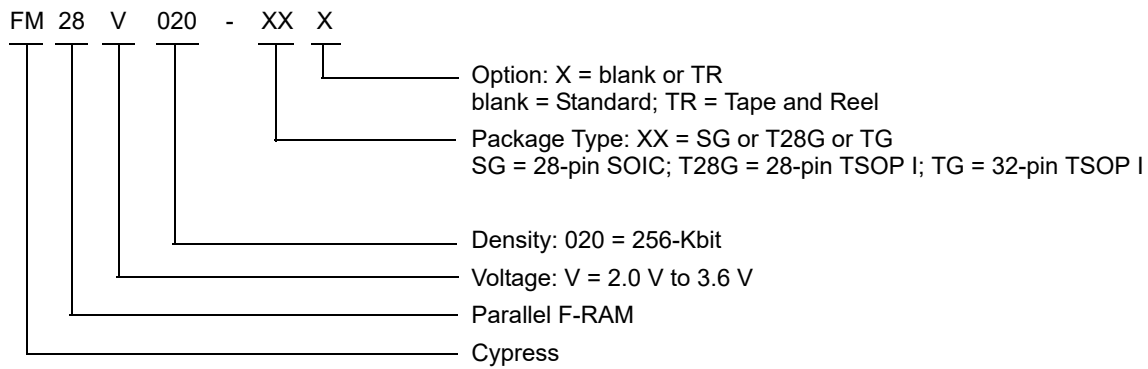

Package Diagrams

Figure 14. 28-pin SOIC Package Outline, 51-85026

NOTE :

1. JEDEC STD REF MO-119
2. BODY LENGTH DIMENSION DOES NOT INCLUDE MOLD PROTRUSION/END FLASH,BUT DOES INCLUDE MOLD MISMATCH AND ARE MEASURED AT THE MOLD PARTING LINE. MOLD PROTRUSION/END FLASH SHALL NOT EXCEED 0.010 in (0.254 mm) PER SIDE
3. DIMENSIONS IN INCHES MIN.
MAX.

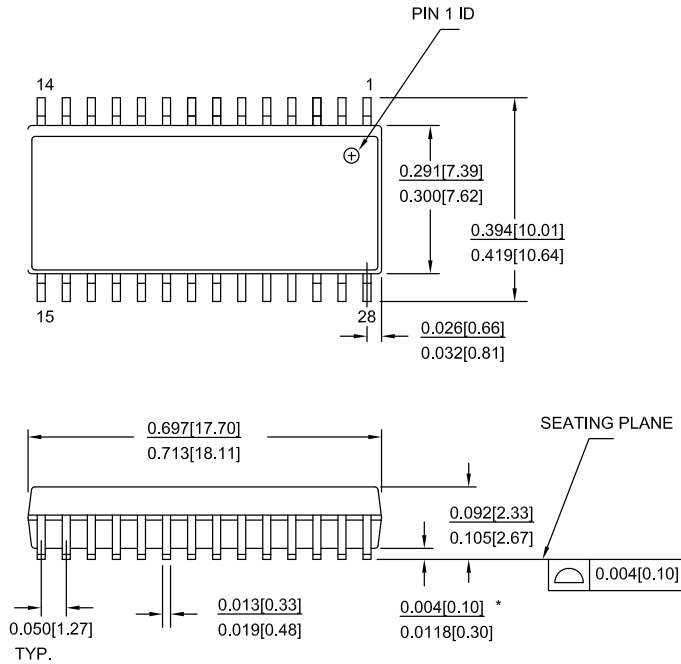

PART #	
S28.3	STANDARD PKG.
SZ28.3	LEAD FREE PKG.
SX28.3	LEAD FREE PKG.

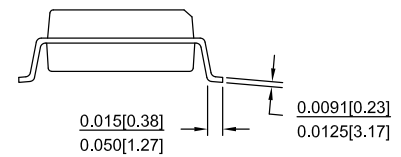

51-85026 *H

Package Diagrams (continued)

Figure 15. 28-pin TSOP I Package Outline, 001-91155

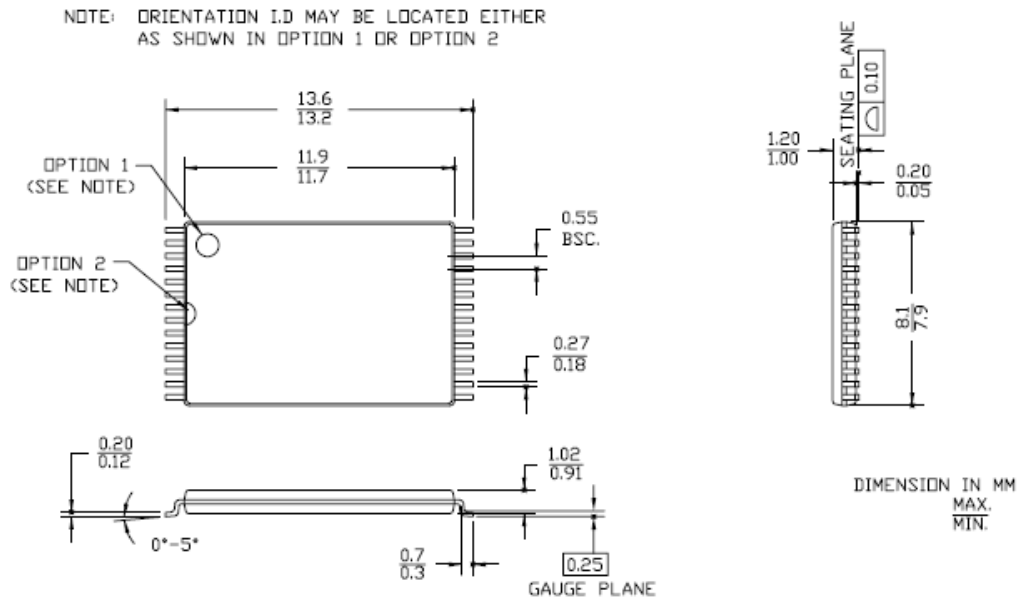

001-91155 **

Package Diagrams (continued)

Figure 16. 32-pin TSOP I Package Outline, 001-91156

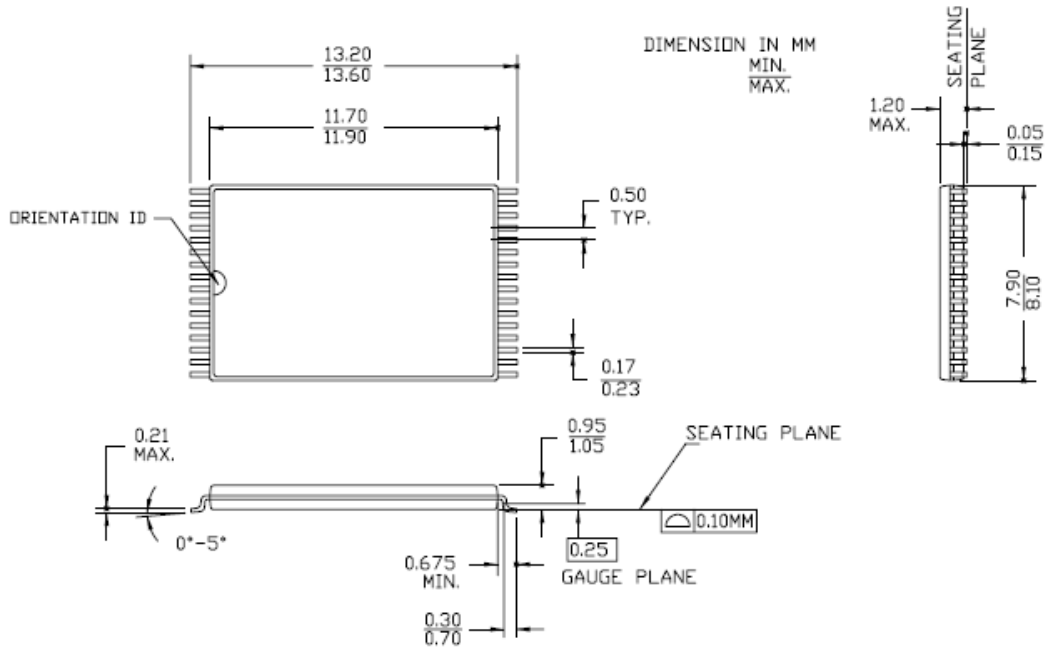

001-91156 **

Acronyms

Acronym	Description
CPU	Central Processing Unit
CMOS	Complementary Metal Oxide Semiconductor
JEDEC	Joint Electron Devices Engineering Council
JESD	JEDEC Standards
EIA	Electronic Industries Alliance
F-RAM	Ferroelectric Random Access Memory
I/O	Input/Output
MCU	Microcontroller Unit
MPU	Microprocessor Unit
RoHS	Restriction of Hazardous Substances
RW	Read and Write
SRAM	Static Random Access Memory
TSOP	Thin Small Outline Package

Document Conventions

Units of Measure

Symbol	Unit of Measure
°C	degree Celsius
Hz	hertz
kHz	kilohertz
kΩ	kilohm
MHz	megahertz
μA	microampere
μF	microfarad
μs	microsecond
mA	milliampere
ms	millisecond
MΩ	megaohm
ns	nanosecond
Ω	ohm
%	percent
pF	picofarad
V	volt
W	watt

Document History Page

Document Title: FM28V020, 256-Kbit (32K × 8) F-RAM Memory Document Number: 001-86204				
Rev.	ECN No.	Orig. of Change	Submission Date	Description of Change
**	3912932	GVCH	02/25/2013	New spec.
*A	3924836	GVCH	03/07/2013	<p>Changed to Production status</p> <p>Added 28-pin TSOP package related information in all instances across the document.</p> <p>Updated DC Electrical Characteristics:</p> <p>Changed typical value of I_{DD} parameter from 7 mA to 5 mA.</p> <p>Changed maximum value of I_{DD} parameter from 12 mA to 8 mA.</p> <p>Updated AC Switching Characteristics:</p> <p>SRAM Read Cycle:</p> <p>Changed maximum value of t_{AAP} parameter from 60 ns to 40 ns.</p> <p>Changed maximum value of t_{OE} parameter from 15 ns to 20 ns.</p> <p>SRAM Write Cycle:</p> <p>Changed minimum value of t_{PWC} parameter from 30 ns to 35 ns.</p> <p>Changed minimum value of t_{AHP} parameter from 15 ns to 20 ns.</p> <p>Updated Ordering Information:</p> <p>Updated part numbers</p>
*B	4000965	GVCH	05/15/2013	Added Appendix A - Errata for FM28V020.
*C	4045491	GVCH	06/30/2013	All errata items are fixed and the errata is removed.
*D	4274812	GVCH	03/11/2014	<p>Updated Maximum Ratings:</p> <p>Added "Maximum Junction Temperature" and its corresponding details.</p> <p>Added "DC voltage applied to outputs in High-Z state" and its corresponding details.</p> <p>Added "Transient voltage (< 20 ns) on any pin to ground potential" and its corresponding details.</p> <p>Added "Package power dissipation capability (T_A = 25 °C)" and its corresponding details.</p> <p>Added "DC output current (1 output at a time, 1s duration)" and its corresponding details.</p> <p>Added "Latch-up Current" and its corresponding details.</p> <p>Removed "Package Moisture Sensitivity Level" and its corresponding details.</p> <p>Updated Data Retention and Endurance:</p> <p>Removed existing details of T_{DR} parameter.</p> <p>Added details of T_{DR} parameter corresponding to "T_A = 85 °C", "T_A = 75 °C" and "T_A = 65 °C".</p> <p>Added NV_C parameter and its corresponding details.</p> <p>Added Thermal Resistance.</p> <p>Updated Package Diagrams:</p> <p>Removed Package Marking Scheme (top mark).</p> <p>Removed "Ramtron Revision History".</p> <p>Updated to Cypress template.</p> <p>Completing Sunset Review.</p>

Document History Page (continued)

Document Title: FM28V020, 256-Kbit (32K × 8) F-RAM Memory Document Number: 001-86204				
Rev.	ECN No.	Orig. of Change	Submission Date	Description of Change
*E	4582540	GVCH	11/28/2014	Updated Functional Description : Added "For a complete list of related documentation, click here ." at the end. Updated Pinouts : Updated Figure 3 : Fixed typo (Replaced V _{DD} with NC for pin 32). Updated Package Diagrams : spec 51-85026 – Changed revision from *G to *H.
*F	4881722	ZSK / PSR	08/12/2015	Updated Maximum Ratings : Removed "Maximum junction temperature" and its corresponding details. Added "Maximum accumulated storage time" and its corresponding details. Added "Ambient temperature with power applied" and its corresponding details. Updated to new template.
*G	5718305	AESATMP7	04/28/2017	Updated Cypress Logo and Copyright.
*H	6389368	GVCH	11/20/2018	Updated Maximum Ratings : Replaced "-55 °C to +125 °C" with "-65 °C to +125 °C" in ratings corresponding to "Storage temperature". Updated to new template.

Sales, Solutions, and Legal Information

Worldwide Sales and Design Support

Cypress maintains a worldwide network of offices, solution centers, manufacturer's representatives, and distributors. To find the office closest to you, visit us at [Cypress Locations](#).

Products

Arm [®] Cortex [®] Microcontrollers	cypress.com/arm
Automotive	cypress.com/automotive
Clocks & Buffers	cypress.com/clocks
Interface	cypress.com/interface
Internet of Things	cypress.com/iot
Memory	cypress.com/memory
Microcontrollers	cypress.com/mcu
PSoC	cypress.com/psoc
Power Management ICs	cypress.com/pmic
Touch Sensing	cypress.com/touch
USB Controllers	cypress.com/usb
Wireless Connectivity	cypress.com/wireless

PSoC[®] Solutions

[PSoC 1](#) | [PSoC 3](#) | [PSoC 4](#) | [PSoC 5LP](#) | [PSoC 6 MCU](#)

Cypress Developer Community

[Community](#) | [Projects](#) | [Video](#) | [Blogs](#) | [Training](#) | [Components](#)

Technical Support

cypress.com/support

All other trademarks or registered trademarks referenced herein are the property of their respective owners.



© Cypress Semiconductor Corporation, 2013–2018. This document is the property of Cypress Semiconductor Corporation and its subsidiaries, including Spansion LLC ("Cypress"). This document, including any software or firmware included or referenced in this document ("Software"), is owned by Cypress under the intellectual property laws and treaties of the United States and other countries worldwide. Cypress reserves all rights under such laws and treaties and does not, except as specifically stated in this paragraph, grant any license under its patents, copyrights, trademarks, or other intellectual property rights. If the Software is not accompanied by a license agreement and you do not otherwise have a written agreement with Cypress governing the use of the Software, then Cypress hereby grants you a personal, non-exclusive, nontransferable license (without the right to sublicense) (1) under its copyright rights in the Software (a) for Software provided in source code form, to modify and reproduce the Software solely for use with Cypress hardware products, only internally within your organization, and (b) to distribute the Software in binary code form externally to end users (either directly or indirectly through resellers and distributors), solely for use on Cypress hardware product units, and (2) under those claims of Cypress's patents that are infringed by the Software (as provided by Cypress, unmodified) to make, use, distribute, and import the Software solely for use with Cypress hardware products. Any other use, reproduction, modification, translation, or compilation of the Software is prohibited.

TO THE EXTENT PERMITTED BY APPLICABLE LAW, CYPRESS MAKES NO WARRANTY OF ANY KIND, EXPRESS OR IMPLIED, WITH REGARD TO THIS DOCUMENT OR ANY SOFTWARE OR ACCOMPANYING HARDWARE, INCLUDING, BUT NOT LIMITED TO, THE IMPLIED WARRANTIES OF MERCHANTABILITY AND FITNESS FOR A PARTICULAR PURPOSE. No computing device can be absolutely secure. Therefore, despite security measures implemented in Cypress hardware or software products, Cypress does not assume any liability arising out of any security breach, such as unauthorized access to or use of a Cypress product. In addition, the products described in these materials may contain design defects or errors known as errata which may cause the product to deviate from published specifications. To the extent permitted by applicable law, Cypress reserves the right to make changes to this document without further notice. Cypress does not assume any liability arising out of the application or use of any product or circuit described in this document. Any information provided in this document, including any sample design information or programming code, is provided only for reference purposes. It is the responsibility of the user of this document to properly design, program, and test the functionality and safety of any application made of this information and any resulting product. Cypress products are not designed, intended, or authorized for use as critical components in systems designed or intended for the operation of weapons, weapons systems, nuclear installations, life-support devices or systems, other medical devices or systems (including resuscitation equipment and surgical implants), pollution control or hazardous substances management, or other uses where the failure of the device or system could cause personal injury, death, or property damage ("Unintended Uses"). A critical component is any component of a device or system whose failure to perform can be reasonably expected to cause the failure of the device or system, or to affect its safety or effectiveness. Cypress is not liable, in whole or in part, and you shall and hereby do release Cypress from any claim, damage, or other liability arising from or related to all Unintended Uses of Cypress products. You shall indemnify and hold Cypress harmless from and against all claims, costs, damages, and other liabilities, including claims for personal injury or death, arising from or related to any Unintended Uses of Cypress products.

Cypress, the Cypress logo, Spansion, the Spansion logo, and combinations thereof, WICED, PSoC, CapSense, EZ-USB, F-RAM, and Traveo are trademarks or registered trademarks of Cypress in the United States and other countries. For a more complete list of Cypress trademarks, visit cypress.com. Other names and brands may be claimed as property of their respective owners.

Looking for pricing, stock, or lifecycle information?

Click below to explore more details on WIN SOURCE:

-  [View FM28V020-TG on WIN SOURCE](#)
-  [Cypress Semiconductor Corp](#) Information

Optimize Your Supply Chain with WIN SOURCE Solutions

-  Global Sourcing Solution
-  Obsolete Management
-  Cost Control Management
-  Shortage Management
-  Alternative Solution
-  Excess Inventory Management