



THE DATASHEET OF PGA281AIPWR



Precision, Zero-Drift, High-Voltage, Programmable Gain Instrumentation Amplifier

Check for Samples: [PGA281](#)

FEATURES

- **Wide Input Range:** $\pm 15.5\text{ V}$ at $\pm 18\text{ V}$ Supply
- **Binary Gain Steps:** 128 V/V to $\frac{1}{8}\text{ V/V}$
- **Additional Scaling Factor:** 1 V/V and $1\frac{1}{2}\text{ V/V}$
- **Low Offset Voltage:** 5 μV at $G = 128$
- **Near-Zero Long-Term Drift of Offset Voltage**
- **Near-Zero Gain Drift:** 0.5 ppm/ $^{\circ}\text{C}$
- **Excellent Linearity:** 1.5 ppm
- **Excellent CMRR:** 140 dB
- **High Input Impedance**
- **Very Low 1/f Noise**
- **Differential Signal Output**
- **Overload Detection**
- **TSSOP-16 Package**

APPLICATIONS

- **High-Precision Signal Instrumentation**
- **Multiplexed Data Acquisition**
- **Medical Instrumentation**
- **Test and Measurement Equipment**
- **Differential or Single-Ended ADC Drivers**
- **Strain Gauge Amplifiers**
- **Industrial Process Control**

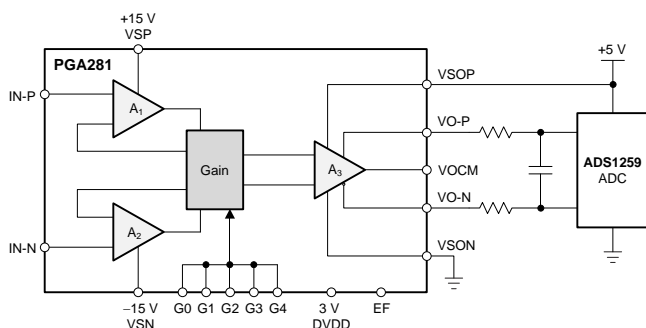

DESCRIPTION

The PGA281 is a high-precision instrumentation amplifier with a digitally-controllable gain and signal-integrity test capability. This device uses proprietary autozeroing techniques to offer low offset voltage, near-zero offset and gain drift, excellent linearity, and nearly no 1/f noise.

The PGA281 is optimized to provide an excellent common-mode rejection of greater than 110 dB ($G = 1$) over a wide frequency range. Superior common-mode and supply rejection supports high-resolution, precise measurement. The 36-V supply capability and wide, high-impedance input range comply with requirements for universal signal measurement.

The PGA281 offers multiple internal gain options from $\frac{1}{8}\text{ V/V}$ (attenuation) to 176 V/V, making this a universal, high-performance, analog front-end suitable for a wide variety of applications. The fully differential, rail-to-rail output is designed to easily interface a wide range of input signals to the low-voltage domain of high-resolution analog-to-digital converters (ADCs).

The PGA281 is available in a TSSOP-16 package and is specified over a temperature range of -40°C to $+105^{\circ}\text{C}$.

RELATED PRODUCTS

PRODUCT	FEATURES
ADS1259	23-bit resolution, $\Delta\Sigma$ analog-to-digital converter
INA333	Chopper-stabilized instrumentation amplifier, RR I/O, 5-V single supply
PGA204	High-precision PGA; $G = 1, 10, 100,$ and 1000
PGA280	Zero-Drift, 36-V, PGA, SPI, GPIOs, input switch matrix



Please be aware that an important notice concerning availability, standard warranty, and use in critical applications of Texas Instruments semiconductor products and disclaimers thereto appears at the end of this data sheet.

TINA-TI is a trademark of Texas Instruments.

Bluetooth is a registered trademark of Bluetooth SIG, Inc.

All other trademarks are the property of their respective owners.



This integrated circuit can be damaged by ESD. Texas Instruments recommends that all integrated circuits be handled with appropriate precautions. Failure to observe proper handling and installation procedures can cause damage.

ESD damage can range from subtle performance degradation to complete device failure. Precision integrated circuits may be more susceptible to damage because very small parametric changes could cause the device not to meet its published specifications.

PACKAGE INFORMATION⁽¹⁾

- (1) For the most current package and ordering information see the Package Option Addendum at the end of this document, or visit the device product folder at www.ti.com.

ABSOLUTE MAXIMUM RATINGS⁽¹⁾

Over operating free-air temperature range, unless otherwise noted.

		VALUE	UNIT
Supply voltage	VSN to VSP	40	V
	VSON to VSOP, and VSON to DVDD	6	V
Signal input terminals, voltage ⁽²⁾		VSN – 0.5 to VSP + 0.5	V
Signal input terminals, current ⁽²⁾		±10	mA
Output short-circuit ⁽³⁾		Continuous	
Operating temperature		–55 to +140	°C
Storage temperature		–65 to +150	°C
Junction temperature		+150	°C
Electrostatic discharge (ESD) ratings	Human body model (HBM)	2000	V

- (1) Stresses above these ratings may cause permanent damage. Exposure to absolute maximum conditions for extended periods may degrade device reliability. These are stress ratings only, and functional operation of the device at these or any other conditions beyond those specified is not implied.
- (2) Terminals are diode-clamped to the power-supply (VON and VOP) rails. Signals that can swing more than 0.5 V beyond the supply rails must be current-limited.
- (3) Short-circuit to VSON or VSOP, respectively, VSON or DVDD.

THERMAL INFORMATION

THERMAL METRIC ⁽¹⁾		PGA281	UNITS
		PW (TSSOP)	
		16 PINS	
θ_{JA}	Junction-to-ambient thermal resistance	92.6	°C/W
θ_{JCTop}	Junction-to-case (top) thermal resistance	23.7	
θ_{JB}	Junction-to-board thermal resistance	37.9	
Ψ_{JT}	Junction-to-top characterization parameter	1.0	
Ψ_{JB}	Junction-to-board characterization parameter	37.3	
θ_{JCbott}	Junction-to-case (bottom) thermal resistance	N/A	

- (1) For more information about traditional and new thermal metrics, see the *IC Package Thermal Metrics* application report, [SPRA953](http://www.ti.com/lit/zip/spra953).

ELECTRICAL CHARACTERISTICS

At $T_A = +25^\circ\text{C}$, $V_{SP} = +15\text{ V}$, $V_{SN} = -15\text{ V}$, $V_{SON} = 0\text{ V}$, $V_{SOP} = 5\text{ V}$, $DVDD = +3\text{ V}$, $R_L = 2.5\text{ k}\Omega$ to $V_{SOP} / 2 = V_{OCM}$, $G = 1\text{ V/V}$, $V_{CM} = 0\text{ V}$, and differential output, unless otherwise noted.

PARAMETER	TEST CONDITIONS	PGA281			UNIT
		MIN	TYP	MAX	
INPUT					
V_{OS}	Offset voltage, RTI ⁽¹⁾	All gains	$\pm(5 + 45/G)$	$\pm(20 + 235/G)$	μV
dV_{OS}/dT	vs temperature ⁽²⁾	All gains	$\pm(0.03 + 0.18/G)$	$\pm(0.17 + 0.45/G)$	$\mu\text{V}/^\circ\text{C}$
PSR	vs power supply, RTI	$V_{SP} - V_{SN} = 10\text{ V}$ and 36 V , gain = 1 V/V , 128 V/V	± 0.3	± 3	$\mu\text{V/V}$
	Long-term stability ⁽³⁾	Gain = 128 V/V	3.5		nV/month
	Input impedance	Single-ended (SE) and differential	>1		G Ω
	Input capacitance	SE	12		pF
	Input voltage range	$T_A = -40^\circ\text{C}$ to $+105^\circ\text{C}$	$(V_{SN}) + 2.5$	$(V_{SP}) - 2.5$	V
CMR	Common-mode rejection, RTI	Gain = 1 V/V , $T_A = -40^\circ\text{C}$ to $+105^\circ\text{C}$	110	130	dB
		Gain = 128 V/V	121	142	dB
		Gain = 128 V/V , $T_A = -40^\circ\text{C}$ to $+105^\circ\text{C}$	116	140	dB
SINGLE-ENDED OUTPUT CONNECTION ⁽⁴⁾					
V_{OS}	Offset voltage, RTI, SE	Gain = 1 V/V , 1.375 V/V	± 120		μV
		Gain = 64 V/V	± 3		μV
dV_{OS}/dT	vs temperature, SE	Gain = 1 V/V , $T_A = -40^\circ\text{C}$ to $+105^\circ\text{C}$	0.6		$\mu\text{V}/^\circ\text{C}$
		Gain = 64 V/V , $T_A = -40^\circ\text{C}$ to $+105^\circ\text{C}$	0.05		$\mu\text{V}/^\circ\text{C}$
INPUT BIAS CURRENT ⁽⁵⁾					
I_B	Bias current	Gain = 1 V/V	± 0.3	± 1	nA
		Gain = 128 V/V	± 0.8	± 2	nA
		Gain = 1 V/V , gain = 128 V/V , $T_A = -40^\circ\text{C}$ to $+105^\circ\text{C}$	± 0.6	± 2	nA
I_{OS}	Offset current	Gain = 1 V/V , gain = 128 V/V	± 0.1	± 0.5	nA
		Gain = 1 V/V , gain = 128 V/V , $T_A = -40^\circ\text{C}$ to $+105^\circ\text{C}$	± 0.9	± 2	nA
NOISE					
e_{NI}	Voltage noise, RTI; target	f = 0.01 Hz to 10 Hz , gain = 128 V/V	420		nV _{PP}
		f = 1 kHz , gain = 128 V/V	22		nV/ $\sqrt{\text{Hz}}$
		f = 0.01 Hz to 10 Hz , gain = 1 V/V	4.5		μV_{PP}
		f = 1 kHz , gain = 1 V/V	240		nV/ $\sqrt{\text{Hz}}$
I_N	Current noise, RTI	f = 0.01 Hz to 10 Hz , gain = 128 V/V	1.7		pA _{PP}
		f = 1 kHz , gain = 128 V/V	90		fA/ $\sqrt{\text{Hz}}$

(1) RTI: Referred to input.

(2) Specified by design; not production tested.

(3) 300-hour life test at $+150^\circ\text{C}$ demonstrated randomly distributed variation in the range of measurement limits.

(4) For single-ended (SE) output mode, see [Application Information](#) section and [Typical Characteristic](#) graphs; signal between VOP and VOCM.

(5) See [Application Information](#) section and [Typical Characteristic](#) graphs.

ELECTRICAL CHARACTERISTICS (continued)

At $T_A = +25^\circ\text{C}$, $V_{SP} = +15\text{ V}$, $V_{SN} = -15\text{ V}$, $V_{SON} = 0\text{ V}$, $V_{SOP} = 5\text{ V}$, $DVDD = +3\text{ V}$, $R_L = 2.5\text{ k}\Omega$ to $V_{SOP} / 2 = \text{VOCM}$, $G = 1\text{ V/V}$, $V_{CM} = 0\text{ V}$, and differential output, unless otherwise noted.

PARAMETER	TEST CONDITIONS	PGA281			UNIT
		MIN	TYP	MAX	
GAIN (Output Swing = $\pm 4.5\text{ V}^{(6)}$)					
Range of input gain		$\frac{1}{8}$		128	V/V
Output gain			1 or 1%		V/V
Gain error, all binary steps	All gains		$\pm 0.03\%$	$\pm 0.15\%$	
	$T_A = -40^\circ\text{C}$ to $+105^\circ\text{C}$, no load, all gains except gain = $128\text{ V/V}^{(7)(8)}$		-0.5	± 2	ppm/ $^\circ\text{C}$
	$T_A = -40^\circ\text{C}$ to $+105^\circ\text{C}$, no load, gain = $128\text{ V/V}^{(7)(8)}$		-1	± 3	ppm/ $^\circ\text{C}$
Gain step matching ⁽⁹⁾ (gain to gain)	No load, all gains	See Typical Characteristics			
Nonlinearity	No load, all gains ⁽¹⁰⁾		1.5	10	ppm
	No load, all gains, $T_A = -40^\circ\text{C}$ to $+105^\circ\text{C}^{(7)}$		3		ppm
OUTPUT					
Voltage output swing from rail ⁽⁹⁾	$V_{SOP} = 5\text{ V}$, load current 2 mA $T_A = -40^\circ\text{C}$ to $+105^\circ\text{C}$		40	100	mV
	$V_{SOP} = 2.7\text{ V}$, load current 1.5 mA $T_A = -40^\circ\text{C}$ to $+105^\circ\text{C}$			100	mV
Capacitive load drive			500		pF
I_{SC} Short-circuit current	To $V_{SOP} / 2$, gain = 1.375 V/V	7	15	25	mA
Output resistance	Both VOP and VON outputs		200		m Ω
VOCM					
Voltage range for VOCM	$V_{SP} - 2\text{ V} > \text{VOCM}$, $T_A = -40^\circ\text{C}$ to $+105^\circ\text{C}$	$(V_{SON}) + 0.1$		$(V_{SOP}) - 0.1$	V
$I_{B(\text{VOCM})}$ Bias current into VOCM			3	100	nA
VOCM input resistance			1		G Ω
FREQUENCY RESPONSE					
GBP Gain bandwidth product ⁽⁹⁾	Gain $> 4\text{ V/V}$		6		MHz
SR Slew rate ⁽⁹⁾	Gain = 1 V/V , $4\text{-}V_{PP}$ output step, $C_L = 100\text{ pF}$		1		V/ μs
	Gain = 8 V/V , $4\text{-}V_{PP}$ output step, $C_L = 100\text{ pF}$		2		V/ μs
	Gain = 128 V/V , $4\text{-}V_{PP}$ output step, $C_L = 100\text{ pF}$		1		V/ μs
t_s Settling time ⁽⁹⁾	To 0.01%, gain = 8 V/V , $V_O = 8\text{-}V_{PP}$ step		20		μs
	To 0.001%, gain = 8 V/V , $V_O = 8\text{-}V_{PP}$ step		30		μs
	To 0.01%, gain = 128 V/V , $V_O = 8\text{-}V_{PP}$ step		30		μs
	To 0.001%, gain = 128 V/V , $V_O = 8\text{-}V_{PP}$ step		40		μs
Overload recovery, input ⁽⁹⁾	0.5 V over supply, gain = $\frac{1}{8}\text{ V/V}$ to 128 V/V		8		μs
Overload recovery, output ⁽⁹⁾	$\pm 5.5\text{-}V_{PP}$ input, gain = 1 V/V		6		μs

(6) Gains smaller than $\frac{1}{2}$ are measured with smaller output swing.

(7) Specified by design; not production tested.

(8) See [Figure 10](#) for typical gain error drift of various gain settings.

(9) See [Application Information](#) section and [Typical Characteristic](#) graphs.

(10) Only gain = 1 is production tested.

ELECTRICAL CHARACTERISTICS (continued)

At $T_A = +25^\circ\text{C}$, $V_{SP} = +15\text{ V}$, $V_{SN} = -15\text{ V}$, $V_{SON} = 0\text{ V}$, $V_{SOP} = 5\text{ V}$, $DVDD = +3\text{ V}$, $R_L = 2.5\text{ k}\Omega$ to $V_{SOP} / 2 = V_{OCM}$, $G = 1\text{ V/V}$, $V_{CM} = 0\text{ V}$, and differential output, unless otherwise noted.

PARAMETER	TEST CONDITIONS	PGA281			UNIT
		MIN	TYP	MAX	
DIGITAL I/O (Supply = 2.7 V to 5.5 V)					
G4:G0 pin input	Logic low threshold	0.1		0.2(DVDD)	V
	Logic high threshold	0.8(DVDD)		DVDD	V
G4:G0 pin input current			0.2		μA
Error flag (EF pin) output	Logic low, disable			0.7	V
	Logic high, alarm	DVDD – 0.5			V
Error flag (EF pin) delay	Alarm → disable (recovery)		5		μs
	Disable → alarm (response)		30		μs
POWER SUPPLY: Input Stage (VSP – VSN)					
Specified voltage range	$T_A = -40^\circ\text{C}$ to $+105^\circ\text{C}$	10 (± 5)		36 (± 18)	V
Operating voltage range		10 (± 5)		38 (± 19)	V
$I_{Q(VSP)}$ Quiescent current, VSP pin	$T_A = -40^\circ\text{C}$ to $+105^\circ\text{C}$		2.4	3	mA
$I_{Q(VSN)}$ Quiescent current, VSN pin	$T_A = -40^\circ\text{C}$ to $+105^\circ\text{C}$		2.1	3	mA
POWER SUPPLY: Output Stage (VSOP – VSON)					
Specified voltage range	$V_{SP} - 1.5\text{ V} \geq V_{SOP}$, $T_A = -40^\circ\text{C}$ to $+105^\circ\text{C}$	2.7		5.5	V
Voltage range for VSOP, upper limit	$(V_{SP} - 2\text{ V}) > V_{OCM}$, $(V_{SP} - 5\text{ V}) > V_{SON}$		(VSP)		V
Voltage range for VSON	$(V_{SP} - 2\text{ V}) > V_{OCM}$, $V_{SP} \geq V_{SOP}$	(VSN)		(VSP) – 5	V
$I_{Q(VSOP)}$ Quiescent current, VSOP pin	$T_A = -40^\circ\text{C}$ to $+105^\circ\text{C}$		0.75	1	mA
POWER SUPPLY: Digital (DVDD – VSON)					
Specified voltage range	$T_A = -40^\circ\text{C}$ to $+105^\circ\text{C}$	2.7		5.5	V
Voltage range for DVDD, upper limit			(VSP) – 1		V
Voltage range for VSON, lower limit			(VSN)		V
$I_{Q(DVDD)}$ Quiescent current ⁽¹¹⁾	Static condition, no external load, $DVDD = 3\text{ V}$, $T_A = -40^\circ\text{C}$ to $+105^\circ\text{C}$		0.07	0.13	mA
TEMPERATURE					
Specified range		–40		+105	$^\circ\text{C}$
Operating range		–55		+140	$^\circ\text{C}$

(11) See [Application Information](#) section and [Typical Characteristic](#) graphs.

PIN CONFIGURATION

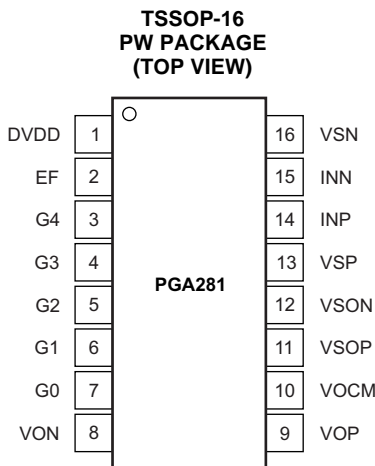

PIN DESCRIPTIONS

PIN		DESCRIPTION	PIN		DESCRIPTION
NAME	NUMBER		NAME	NUMBER	
DVDD	1	Digital supply	INN	15	Signal input, inverting
EF	2	Error flag (output)	INP	14	Signal input, noninverting
VSON	12	Negative output-stage low-voltage supply and negative digital supply	VOCM	10	Signal input, output common-mode voltage
G0	7	Gain option 1 (see Table 1)	VON	8	Inverting signal output
G1	6	Gain option 2 (see Table 1)	VOP	9	Noninverting signal output
G2	5	Gain option 3 (see Table 1)	VSOP	11	Positive output-stage low-voltage supply
G3	4	Gain option 4 (see Table 1)	VSN	16	Negative high-voltage supply
G4	3	Gain option 5 (see Table 1)	VSP	13	Positive high-voltage supply

Table 1. Gain Control

G3:G0	G4 = 0	G4 = 1
0000	0.125	0.172
0001	0.25	0.344
0010	0.5	0.688
0011	1	1.375
0100	2	2.75
0101	4	5.5
0110	8	11
0111	16	22
1000	32	44
1001	64	88
1010	128	176
1011	Reserved ⁽¹⁾ (0.125)	Reserved ⁽¹⁾ (0.172)
1100	Reserved ⁽¹⁾ (0.125)	Reserved ⁽¹⁾ (0.172)
1101	Reserved ⁽¹⁾ (0.125)	Reserved ⁽¹⁾ (0.172)
1110	Reserved ⁽¹⁾ (0.125)	Reserved ⁽¹⁾ (0.172)
1111	Reserved ⁽¹⁾ (0.125)	Reserved ⁽¹⁾ (0.172)

(1) Reserved for test-modes. Default gain in parenthesis.

TYPICAL CHARACTERISTICS

At $T_A = +25^\circ\text{C}$, $V_{SP} = +15\text{ V}$, $V_{SN} = -15\text{ V}$, $V_{SON} = 0\text{ V}$, $V_{SOP} = 5\text{ V}$, $DV_{DD} = +3\text{ V}$, $R_L = 2.5\text{ k}\Omega$ to $V_{SOP}/2 = V_{OCM}$, gain = 1 V/V , $V_{CM} = 0\text{ V}$, and differential input and output, unless otherwise noted.

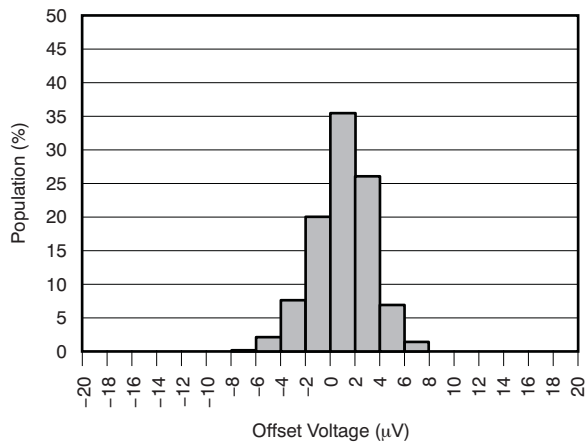

Figure 1. OFFSET VOLTAGE PRODUCTION DISTRIBUTION (G = 128)

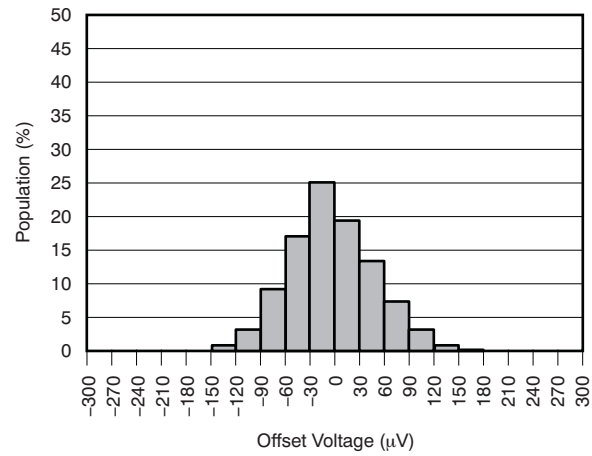

Figure 2. OFFSET VOLTAGE PRODUCTION DISTRIBUTION (G = 1)

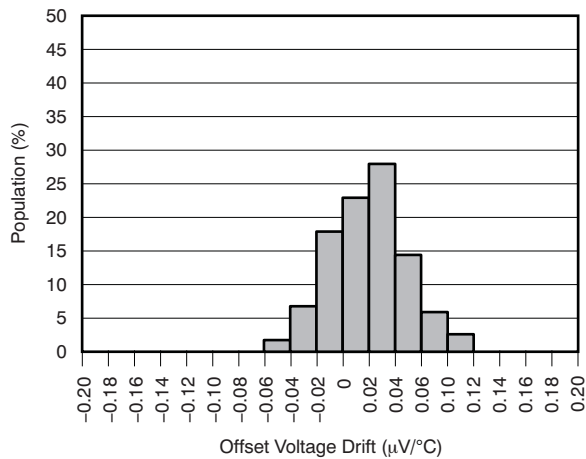

Figure 3. OFFSET VOLTAGE DRIFT DISTRIBUTION (G = 128)

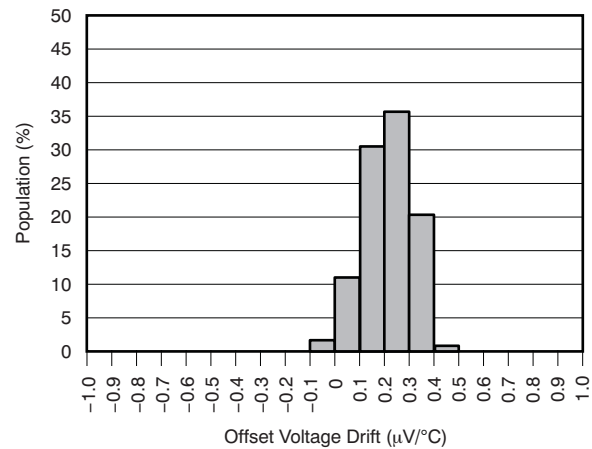

Figure 4. OFFSET VOLTAGE DRIFT DISTRIBUTION (G = 1)

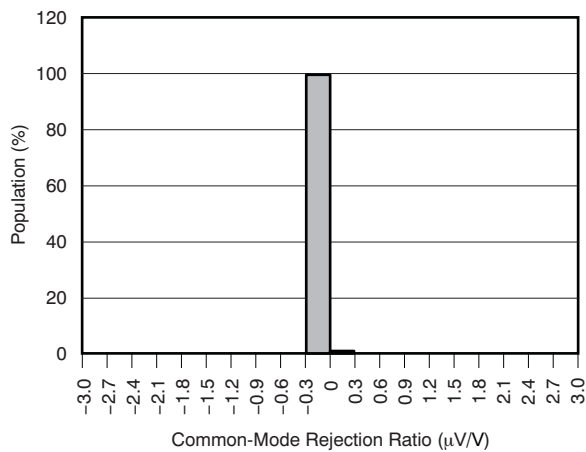

Figure 5. COMMON-MODE REJECTION DISTRIBUTION (G = 128)

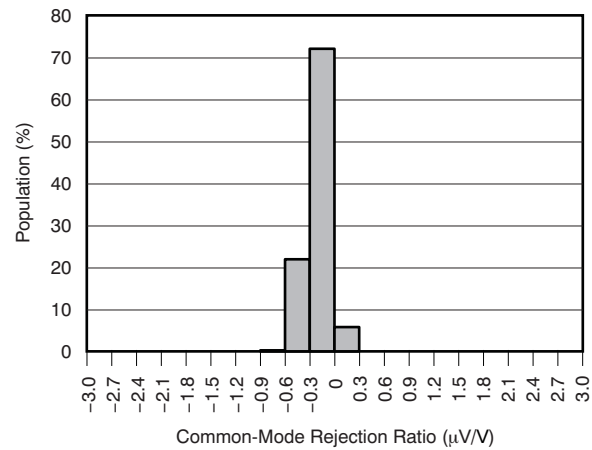

Figure 6. COMMON-MODE REJECTION DISTRIBUTION (G = 1)

TYPICAL CHARACTERISTICS (continued)

At $T_A = +25^\circ\text{C}$, $V_{SP} = +15\text{ V}$, $V_{SN} = -15\text{ V}$, $V_{SON} = 0\text{ V}$, $V_{SOP} = 5\text{ V}$, $DV_{DD} = +3\text{ V}$, $R_L = 2.5\text{ k}\Omega$ to $V_{SOP}/2 = V_{OCM}$, gain = 1 V/V , $V_{CM} = 0\text{ V}$, and differential input and output, unless otherwise noted.

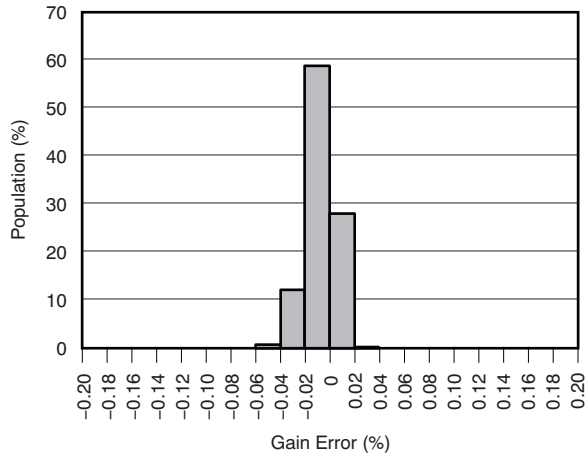

Figure 7. GAIN ERROR DISTRIBUTION (G = 128)

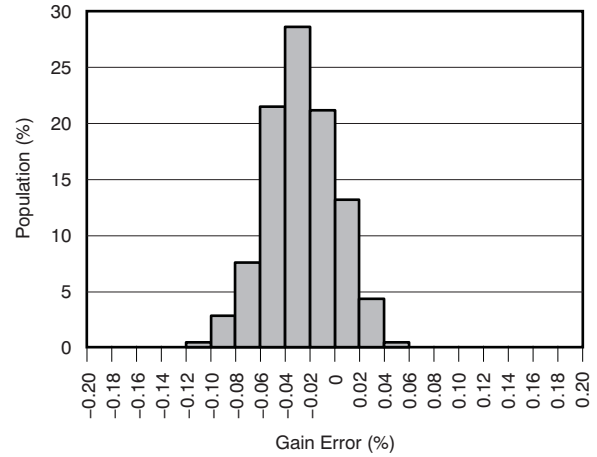

Figure 8. GAIN ERROR DISTRIBUTION (G = 1)

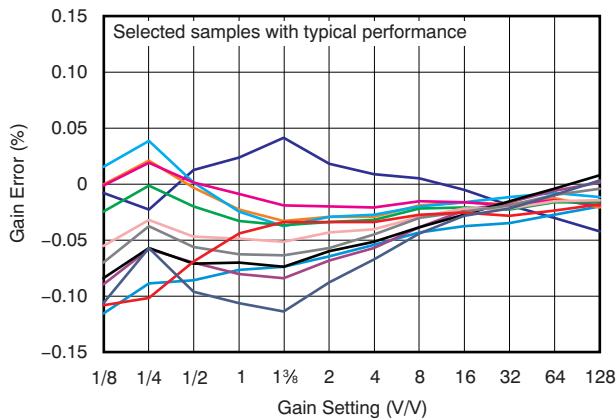

Figure 9. GAIN ERROR vs GAIN SETTING

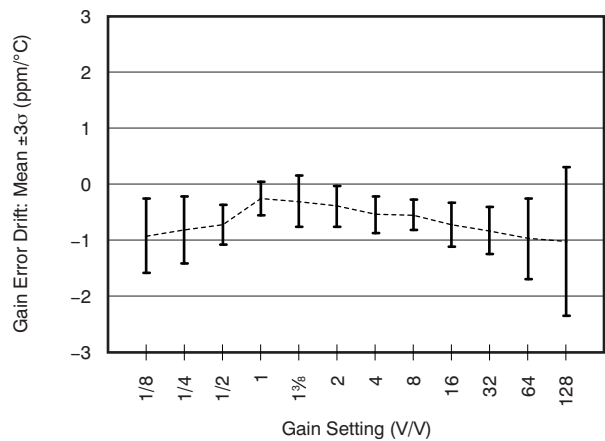

Figure 10. GAIN ERROR DRIFT DISTRIBUTION vs GAIN SETTING (Mean with $\pm 3\sigma$)

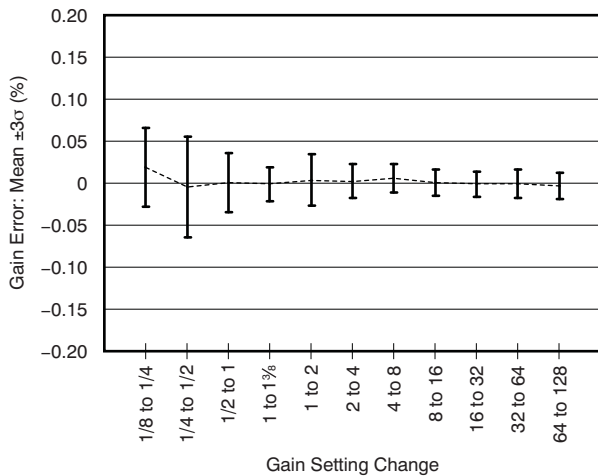

Figure 11. MAXIMUM GAIN ERROR DEVIATION BETWEEN SEQUENTIAL GAIN SETTINGS (Mean with $\pm 3\sigma$)

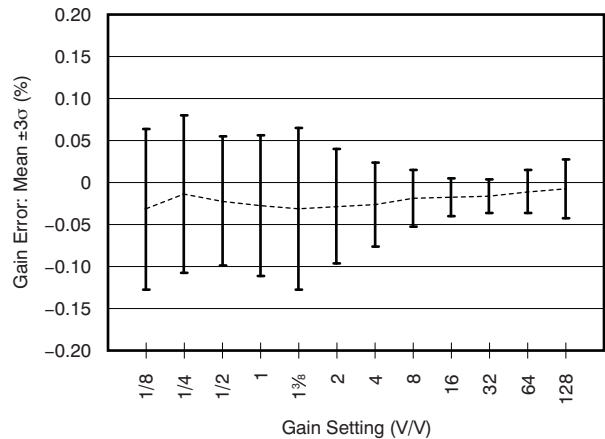

Figure 12. GAIN ERROR DISTRIBUTION vs GAIN SETTING (MEAN with $\pm 3\sigma$)

TYPICAL CHARACTERISTICS (continued)

At $T_A = +25^\circ\text{C}$, $V_{SP} = +15\text{ V}$, $V_{SN} = -15\text{ V}$, $V_{SON} = 0\text{ V}$, $V_{SOP} = 5\text{ V}$, $DV_{DD} = +3\text{ V}$, $R_L = 2.5\text{ k}\Omega$ to $V_{SOP}/2 = V_{OCM}$, gain = 1 V/V , $V_{CM} = 0\text{ V}$, and differential input and output, unless otherwise noted.

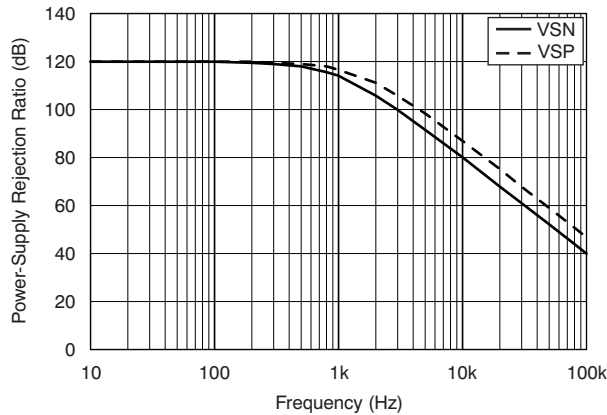

Figure 13. POWER-SUPPLY REJECTION vs FREQUENCY

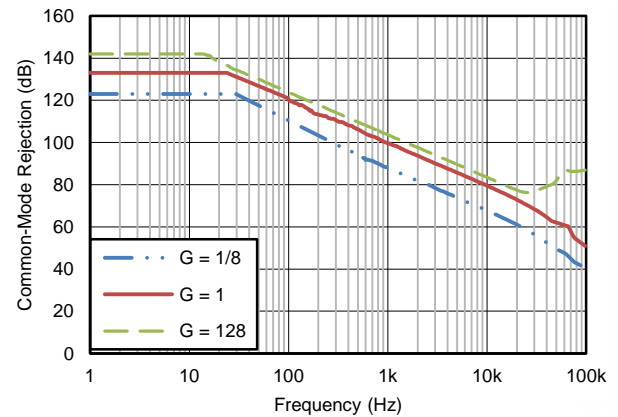

Figure 14. COMMON-MODE REJECTION vs FREQUENCY

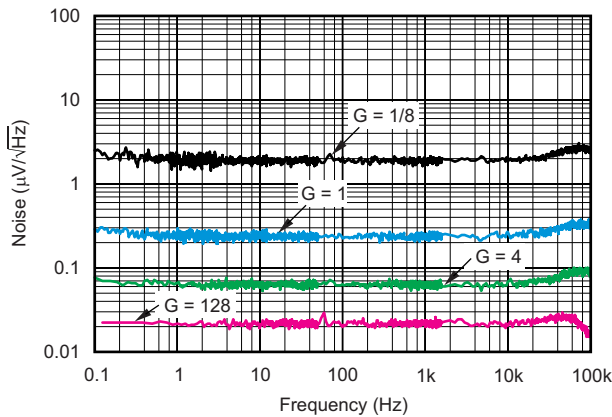

Figure 15. INPUT-REFERRED NOISE SPECTRUM

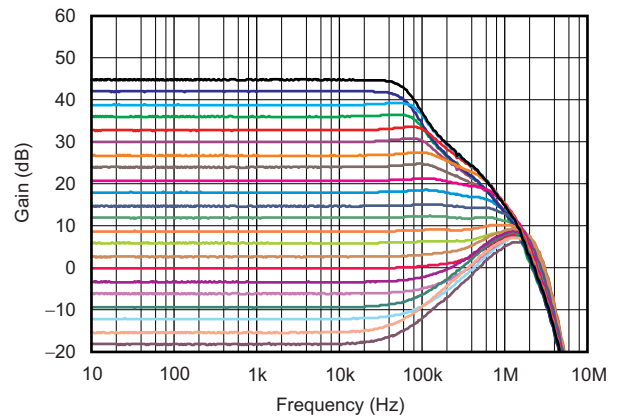

Figure 16. SMALL-SIGNAL GAIN vs FREQUENCY

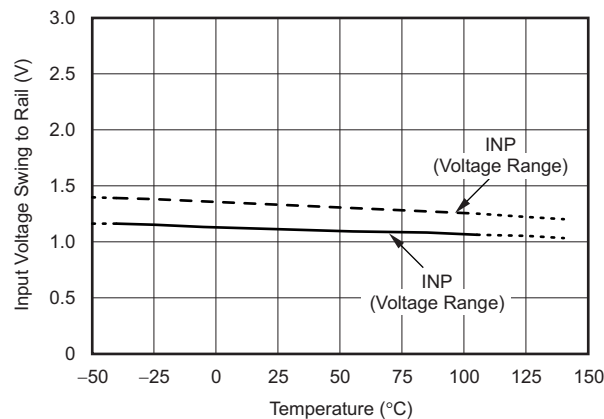

Figure 17. INPUT VOLTAGE RANGE LIMITS vs TEMPERATURE

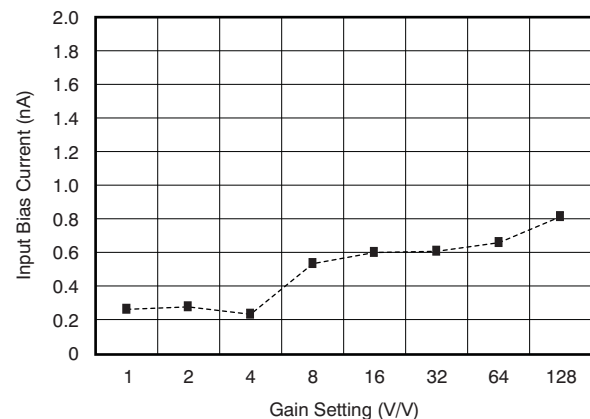

Figure 18. BIAS CURRENT vs GAIN SETTING

TYPICAL CHARACTERISTICS (continued)

At $T_A = +25^\circ\text{C}$, $V_{SP} = +15\text{ V}$, $V_{SN} = -15\text{ V}$, $V_{SON} = 0\text{ V}$, $V_{SOP} = 5\text{ V}$, $DV_{DD} = +3\text{ V}$, $R_L = 2.5\text{ k}\Omega$ to $V_{SOP}/2 = V_{OCM}$, gain = 1 V/V , $V_{CM} = 0\text{ V}$, and differential input and output, unless otherwise noted.

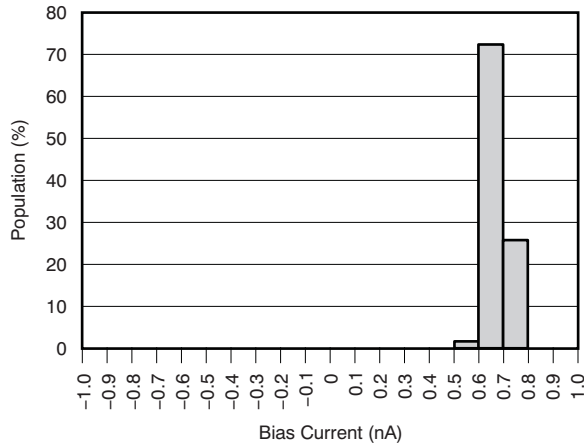

Figure 19. INPUT BIAS CURRENT DISTRIBUTION (G = 128)

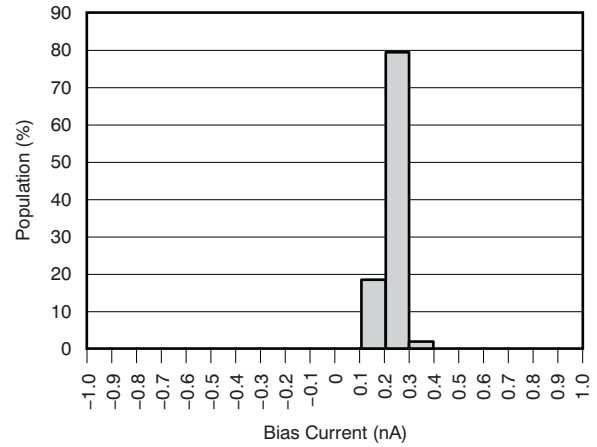

Figure 20. INPUT BIAS CURRENT DISTRIBUTION (G = 1)

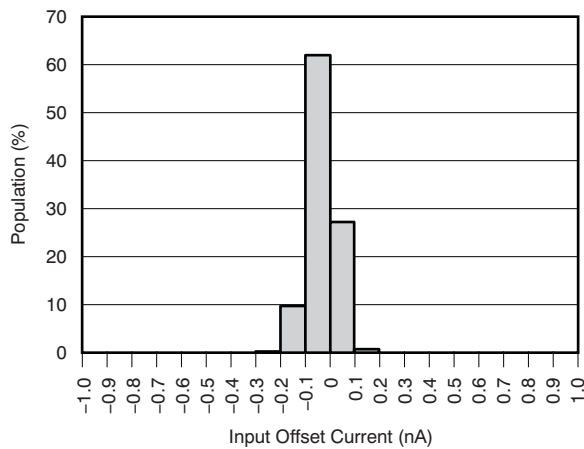

Figure 21. INPUT OFFSET CURRENT DISTRIBUTION (G = 1, G = 128)

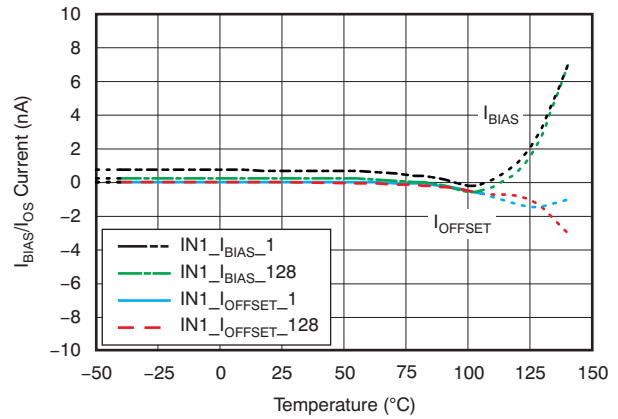

Figure 22. INPUT BIAS CURRENT AND INPUT OFFSET CURRENT vs TEMPERATURE

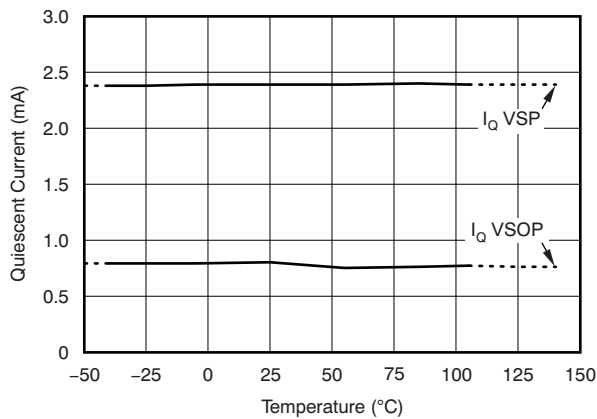

Figure 23. QUIESCENT CURRENT FROM SUPPLIES (VSP AND VSOP) vs TEMPERATURE

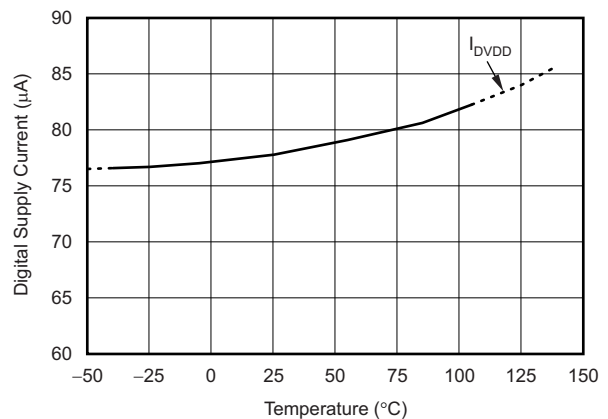

Figure 24. DIGITAL SUPPLY CURRENT vs TEMPERATURE

TYPICAL CHARACTERISTICS (continued)

At $T_A = +25^\circ\text{C}$, $V_{SP} = +15\text{ V}$, $V_{SN} = -15\text{ V}$, $V_{SON} = 0\text{ V}$, $V_{SOP} = 5\text{ V}$, $DV_{DD} = +3\text{ V}$, $R_L = 2.5\text{ k}\Omega$ to $V_{SOP}/2 = V_{OCM}$, gain = 1 V/V , $V_{CM} = 0\text{ V}$, and differential input and output, unless otherwise noted.

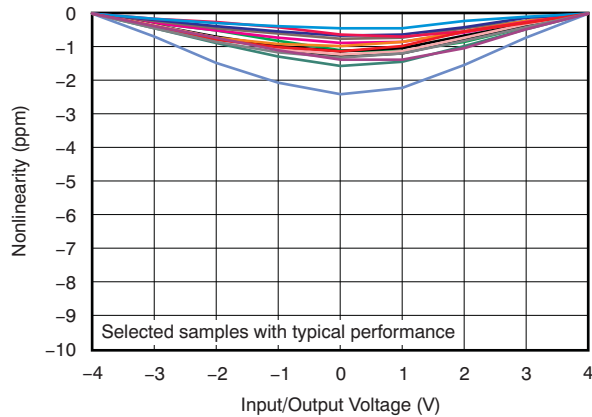

Figure 25. GAIN NONLINEARITY WITH END-POINT CALIBRATION (G = 1)

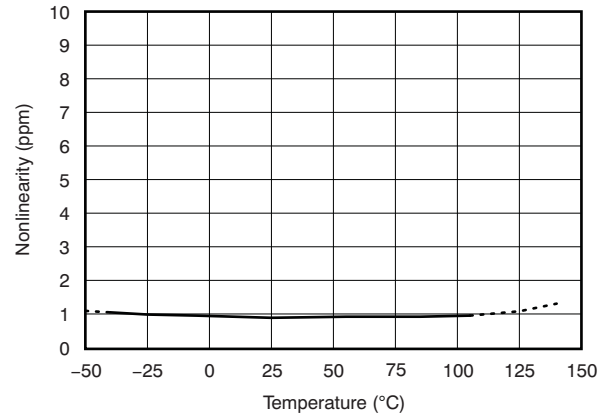

Figure 26. GAIN NONLINEARITY vs TEMPERATURE

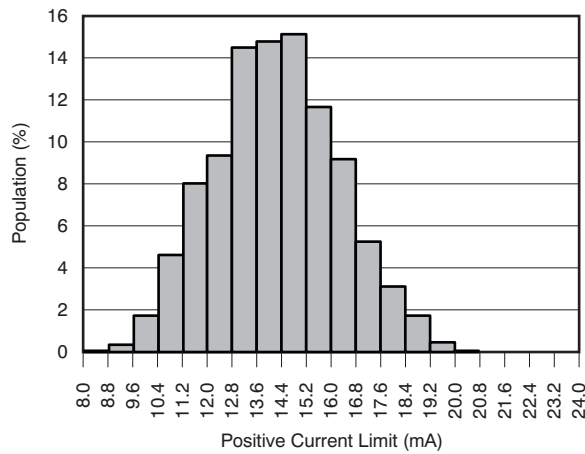

Figure 27. POSITIVE OUTPUT CURRENT LIMIT DISTRIBUTION

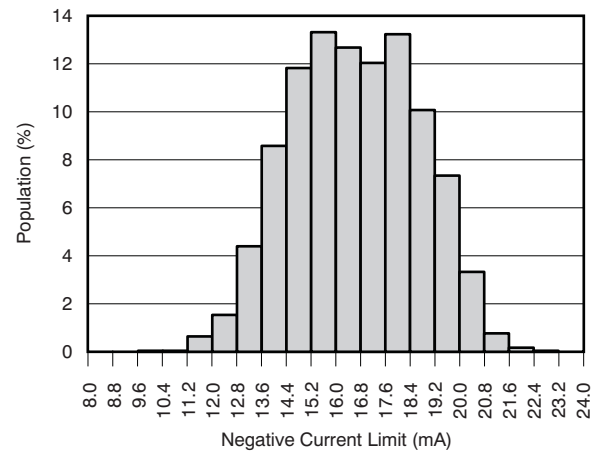

Figure 28. NEGATIVE OUTPUT CURRENT LIMIT DISTRIBUTION

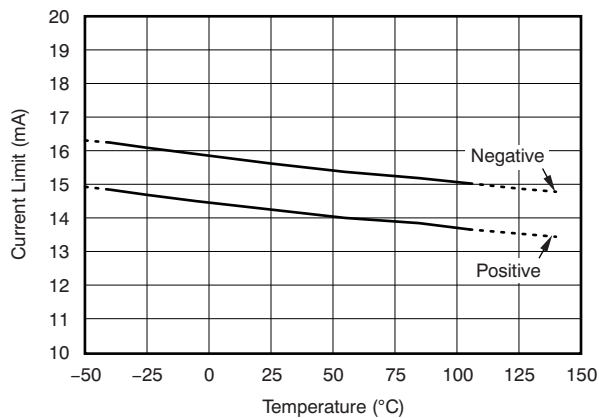

Figure 29. OUTPUT CURRENT LIMIT vs TEMPERATURE

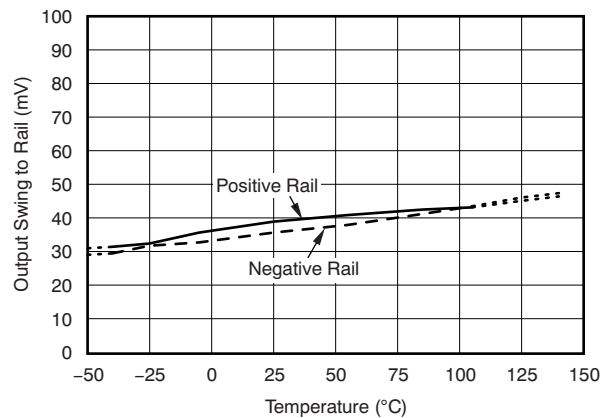

Figure 30. OUTPUT SWING TO RAIL vs TEMPERATURE (VSOP - VSON = 5 V)

TYPICAL CHARACTERISTICS (continued)

At $T_A = +25^\circ\text{C}$, $V_{SP} = +15\text{ V}$, $V_{SN} = -15\text{ V}$, $V_{SON} = 0\text{ V}$, $V_{SOP} = 5\text{ V}$, $DV_{DD} = +3\text{ V}$, $R_L = 2.5\text{ k}\Omega$ to $V_{SOP}/2 = V_{OCM}$, gain = 1 V/V , $V_{CM} = 0\text{ V}$, and differential input and output, unless otherwise noted.

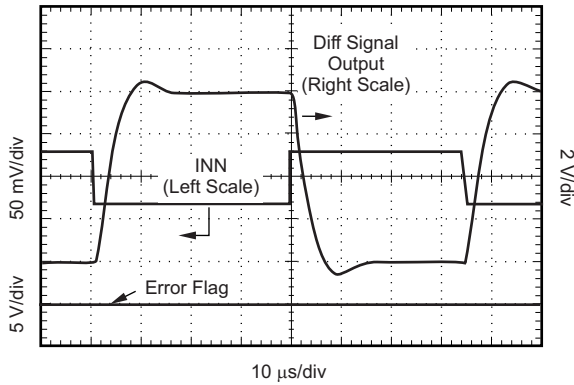

Figure 31. STEP RESPONSE (G = 128)

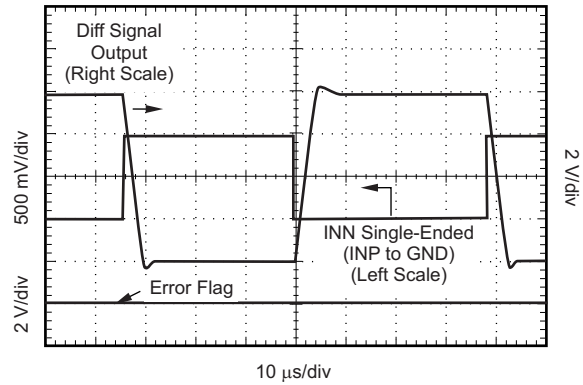

Figure 32. STEP RESPONSE (G = 8)

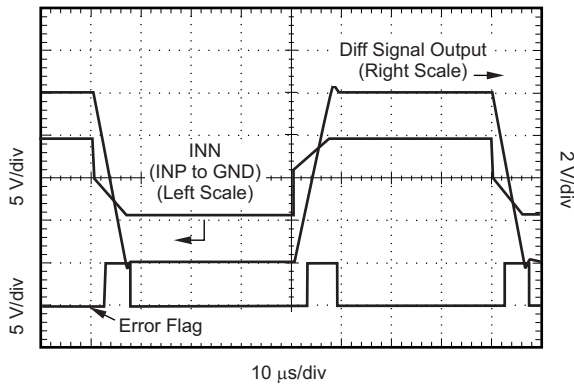

Figure 33. STEP RESPONSE (G = 1)

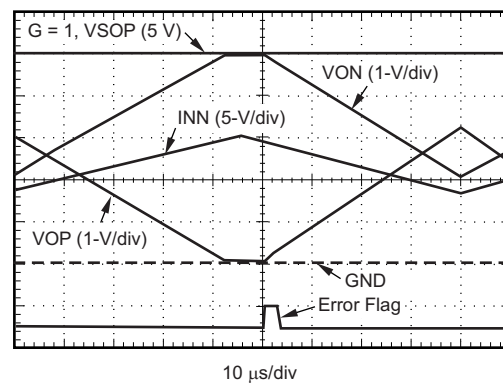

Figure 34. OUTPUT OVERLOAD RECOVERY

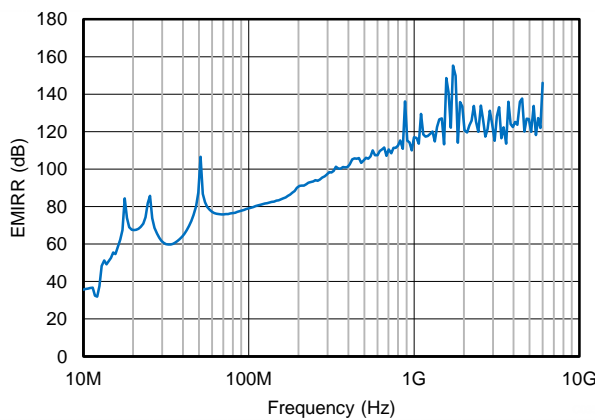

Figure 35. COMMON MODE EMIRR

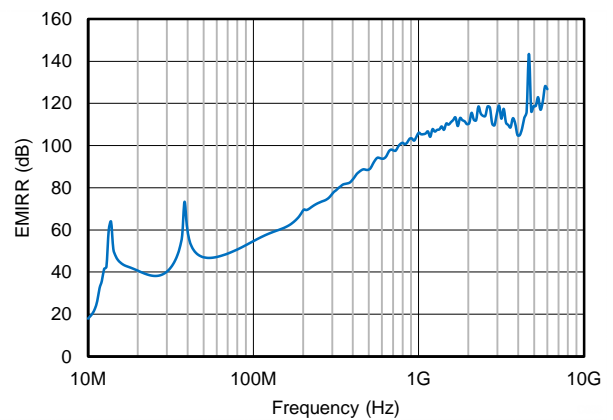

Figure 36. DIFFERENTIAL MODE EMIRR

APPLICATION INFORMATION

DESCRIPTION

The PGA281 is a universal high-voltage instrumentation amplifier with digital gain control. It offers excellent dc precision and long-term stability using modern chopper technology with internal filters that minimize chopper-related noise. The input gain extends from $\frac{1}{8}$ V/V (attenuation) to 128 V/V in binary steps. The output stage offers a gain multiplying factor of 1 V/V or $1\frac{3}{8}$ V/V for optimal gain adjustment. The output stage connects to the low-voltage (for example: 5 V or 3 V) supply. [Figure 37](#) shows a block diagram of the PGA281.

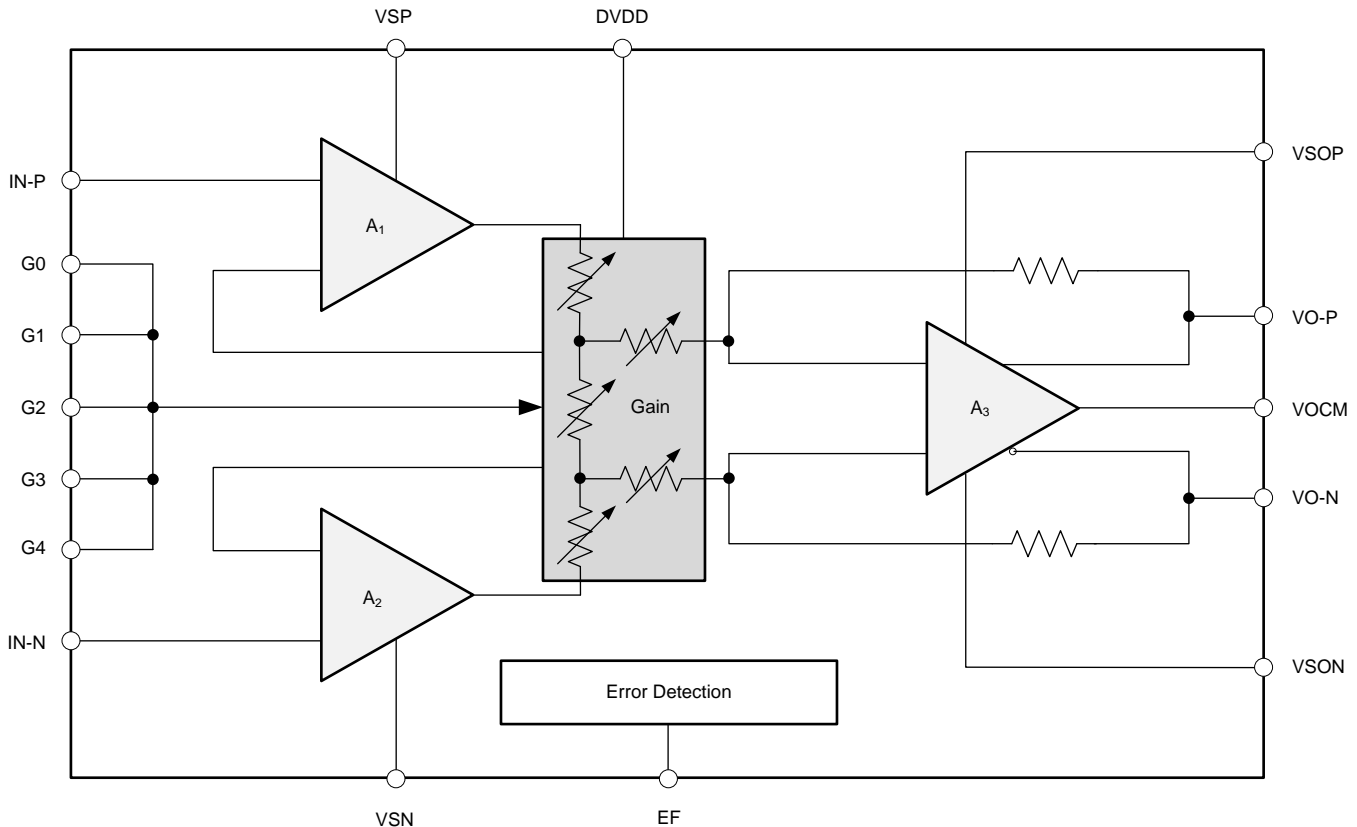

Figure 37. Block Diagram

The supply voltage of up to ± 18 V offers a wide common-mode range with high input impedance; therefore, large common-mode noise signals and offsets can be suppressed.

The fully differential signal output is compatible with the inputs of modern high-resolution and high-accuracy analog-to-digital converters (ADCs), including delta-sigma ($\Delta\Sigma$) as well as successive-approximation register (SAR) converters. The supply voltage for the output stage is normally connected to the converter supply, thus preventing signal overloads from the high-voltage analog supply.

Internal error detection in the input and output stage monitors signal integrity and provides information about the input signal condition on the EF pin output.

The gain is set using digital inputs G4:G0 (pins 3, 4, 5, 6, and 7). Select the desired gain according to the settings in [Table 1](#). Logic high and low levels are with respect to the voltage on DVDD (pin 1) and VSON (pin 12). The limits are specified in the *Digital I/O* section of the [Electrical Characteristics](#).

FUNCTIONAL BLOCKS

The PGA281 has two high-impedance input amplifiers (see [Figure 37](#), A_1 and A_2) that are symmetrical and low noise, with excellent dc precision. These amplifiers are connected to a resistor network and provide a gain range from 128 V/V down to an attenuation of $\frac{1}{8}$ V/V. The PGA281 architecture rejects common-mode offsets and noise over a wide bandwidth.

The signal inputs are diode-clamped to the supply rails. To provide overvoltage protection, place external resistors in series to the inputs. Limit current into the input pins to ≤ 10 mA.

The output stage (A_3) provides a fully-differential symmetrical signal around the output reference pin, VOCM. The VOCM pin is a high-impedance input and must be driven with an external voltage, typically close to midsupply. The 3-V or 5-V supply of the converter or amplifier, following the PGA281 outputs, is normally connected to VSOP and VSON; this configuration shares a common supply voltage and protects the circuit from overloads. The fully-differential signal avoids coupling of noise and errors from the supply and ground, and allows large signal swing without the risk of nonlinearities that arise when driving near the supply rails.

The PGA281 signal path has several internal nodes monitored for critical overload conditions. The input amplifiers detect signal overvoltage and overload as a result of high gain. The output stage also detects clipping.

Input Amplifiers and Gain Network

The high-precision input amplifiers present very low dc error and drift as a result of a modern chopper technology with an embedded synchronous filter that removes nearly all chopping noise. This topology reduces flicker ($1/f$) noise to a minimum, and therefore enables the precise measurement of small dc-signals with high resolution, accuracy, and repeatability. The chopping frequency of 250 kHz is derived from an internal 1-MHz clock.

The gain network for the binary gain steps connects to the input amplifiers, thus providing the best possible signal-to-noise ratio (SNR) and dc accuracy up to the highest gains. Gain is digitally programmable by pins G4:G0. The input stage provides selectable gains (in V/V): 128, 64, 32, 16, 8, 4, 2, 1, $\frac{1}{2}$, $\frac{1}{4}$, and $\frac{1}{8}$. The G4 pin provides an additional gain multiplication factor on the output stage of 1 V/V or $1\frac{3}{8}$ V/V. This allows for optimal gain fine-tuning, and increases the maximum gain of the PGA281 to 176 V/V.

Programmable gain amplifiers such as the PGA281 use internal resistors to set the gain. Consequently, quiescent current is increased by the current that passes through these resistors. The largest amplitude may increase the supply current by ± 0.4 mA. For example, in a maximum overload condition, with a gain of 128 V/V, and with each of the inputs connected to the opposite supply voltage, a current of approximately 27 mA is measured. External resistors in series with the input pins are normally present and help to avoid this extreme condition. This current is only limited by the internal 600 Ω .

Digital Inputs

Digital inputs G0, G1, G2, G3, and G4, select the gain according to the settings shown in [Table 1](#). Logic high and low levels are with respect to the voltage on DVDD (pin 1) and VSON (pin 12). The logic limits are specified in the *Digital I/O* section of the [Electrical Characteristics](#). Approximately 0.2 μ A flows out of the digital input pins when a logic '0' is applied. Logic input current is nearly zero with a logic '1' input.

Digital inputs G4:G0 are not latched; a change in logic inputs immediately selects a new gain. Switching time of the logic is approximately 1 μ s. The time to respond to gain change is effectively the time it takes the amplifier to settle to a new output voltage in the newly selected gain (see the settling times specified in the *Frequency Response* section of the [Electrical Characteristics](#)). Many applications use an external logic latch to access gain control data from a high-speed data bus. Using an external latch isolates the high-speed digital bus from sensitive analog circuitry. Place the latch circuitry as far as practical from analog circuitry.

Output Stage

The output stage power supply is usually connected to the low-voltage supply (normally 3 V or 5 V) that is used by the subsequent signal path of the system. This design prevents overloading of the low-voltage signal path.

The output signal is fully differential around the common-mode voltage (VOCM). The VOCM input pin is typically connected to the midsupply voltage in order to offer the widest signal amplitude range. VOCM is a high-impedance input that requires an external connection to a voltage within the supply boundaries. If the VOCM pin is left floating, the output common-mode voltage is undefined, and the amplifier will not operate properly. The usable voltage range for the VOCM input is specified in the [Electrical Characteristics](#) and must be observed.

The output stage can be set to a gain of 1V/V or 1½V/V with the G4 pin logic level. This option allows for additional gain fine tuning.

Figure 38 shows how signal outputs VOP and VON swing symmetrically around VOCM. The signal is represented as the voltage between the two outputs and does not require an accurate VOCM. Therefore, the signal output does not include ground noise or grounding errors. Noise or drift on VOCM is normally rejected by the common-mode rejection capability of the subsequent signal stage. By using a differential output stage, the PGA281 achieves large voltage swings on a single 3-V or 5-V supply.

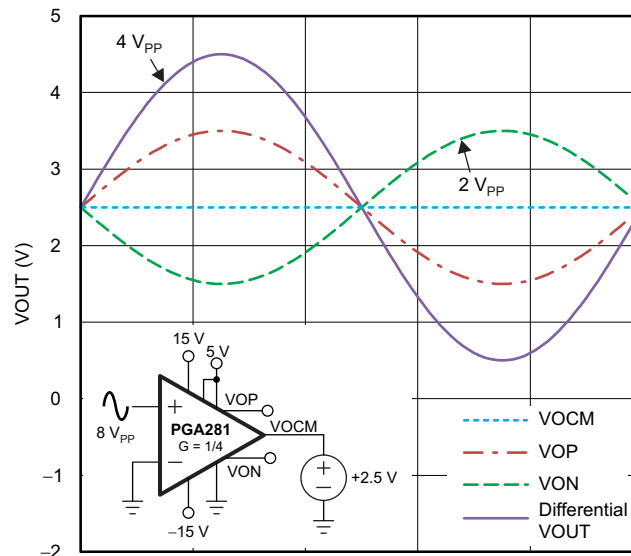

Figure 38. Differential Output Voltage

The output signal is internally monitored for two error conditions: clipping of the signal to the supply rail and overcurrent. In fault conditions, an error flag bit is set high until the fault is removed.

Electrical Overstress

Designers often ask questions about the capability of an amplifier to withstand electrical overstress. These questions tend to focus on the device inputs, but may involve the supply voltage pins or even the output pin. Each of these different pin functions have electrical stress limits determined by the voltage breakdown characteristics of the particular semiconductor fabrication process and specific circuits connected to the pin. Additionally, internal ESD protection is built into these circuits to protect them from accidental ESD events both before and during product assembly.

Having a good understanding of this basic ESD circuitry and its relevance to an electrical overstress event is helpful. [Figure 39](#) illustrates the ESD circuits contained in the PGA281. The ESD protection circuitry involves several current-steering diodes connected from the input and output pins and routed back to the internal power-supply lines. This protection circuitry is intended to remain inactive during normal circuit operation.

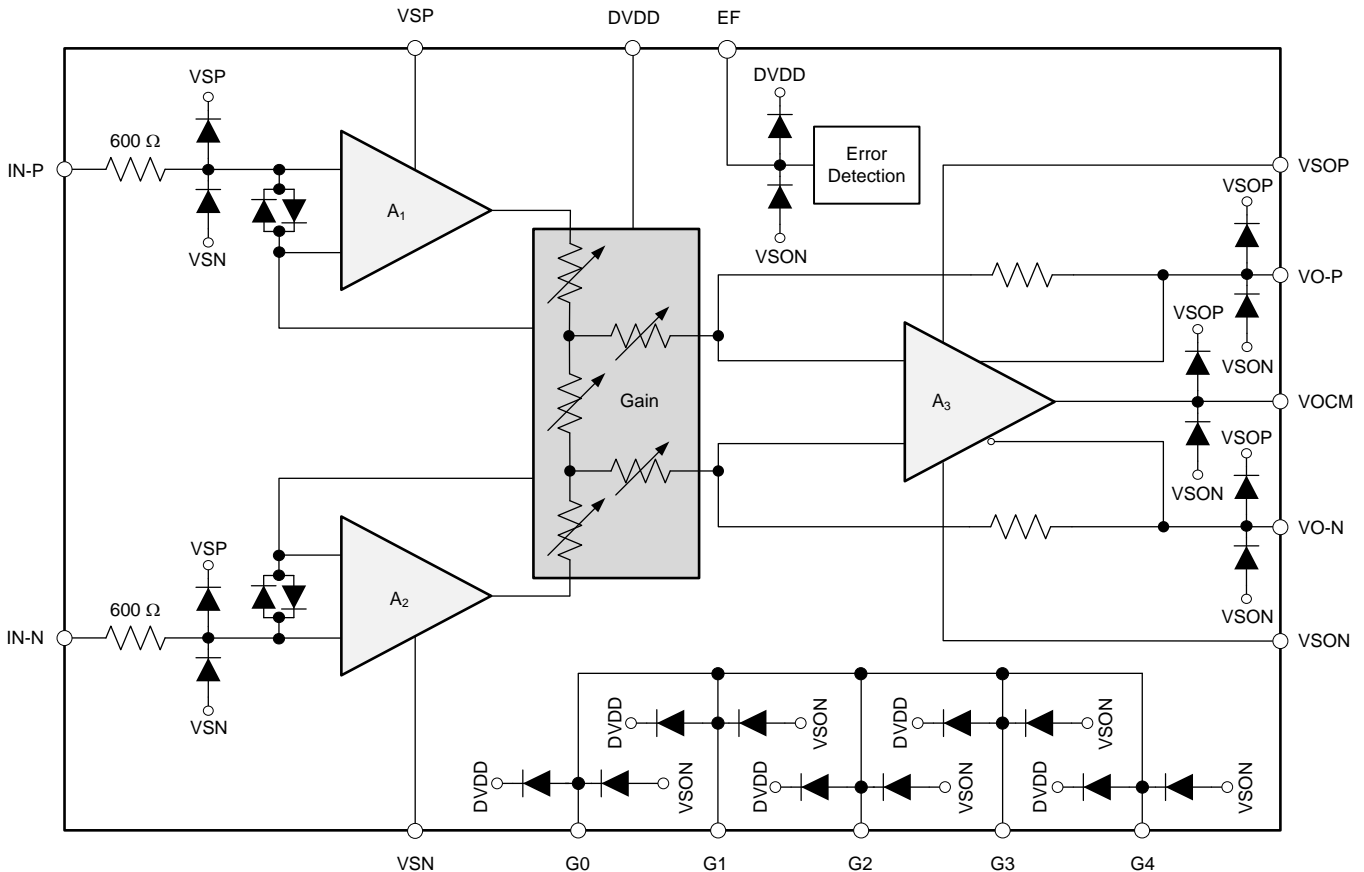

Figure 39. Equivalent Internal ESD Circuitry

The PGA281 input terminals are protected with internal diodes connected to VSP and VSN. If the input signal voltage exceeds the power-supply voltage (VSP and VSN), limit the current to less than 10 mA to protect the internal clamp diodes. This current-limiting can usually be accomplished with a series input resistor.

EMI Rejection

The PGA281 uses integrated electromagnetic interference (EMI) filtering to reduce the effects of EMI from sources such as wireless communications, and densely-populated boards with a mix of analog signal chain and digital components. The PGA281 is specifically designed to minimize susceptibility to EMI by incorporating an internal low-pass filter. Depending on the end-system requirements, additional EMI filters may be required near the signal inputs of the system, as well as incorporating known good practices such as using short traces, low-pass filters, and damping resistors combined with parallel and shielded signal routing. Texas Instruments developed a method to accurately measure the immunity of an amplifier over a broad frequency spectrum, extending from 10 MHz to 6 GHz. This method uses EMI rejection ratio (EMIRR) to quantify the PGA281 ability to reject EMI. [Figure 40](#) and [Figure 41](#) show the PGA281 EMIRR graph for both differential and common-mode EMI rejection across this frequency range. [Table 2](#) shows the EMIRR values for the PGA281 at frequencies commonly encountered in real-world applications. Applications listed in [Table 2](#) may be centered on or operated near the particular frequency shown.

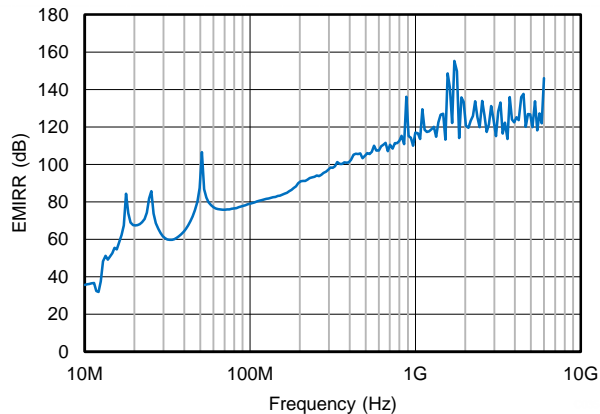

Figure 40. Common Mode EMIRR Testing

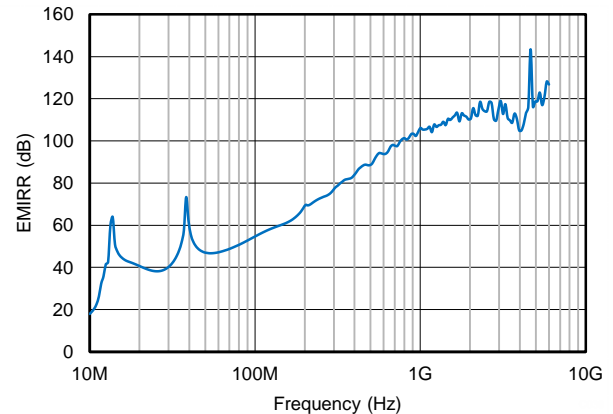

Figure 41. Differential Mode (IN-P) EMIRR Testing

Table 2. PGA281 EMIRR for Frequencies of Interest

FREQUENCY	APPLICATION OR ALLOCATION	DIFFERENTIAL (IN-P) EMIRR	COMMON-MODE EMIRR
400 MHz	Mobile radio, mobile satellite, space operation, weather, radar, ultra-high frequency (UHF) applications	84.3 dB	101.8 dB
900 MHz	Global system for mobile communications (GSM) applications, radio communication, navigation, GPS (to 1.6 GHz), GSM, aeronautical mobile, UHF applications	103.3 dB	125.6 dB
1.8 GHz	GSM applications, mobile personal communications, broadband, satellite, L-band (1 GHz to 2 GHz)	112.5 dB	131.8 dB
2.4 GHz	802.11b, 802.11g, 802.11n, Bluetooth®, mobile personal communications, industrial, scientific and medical (ISM) radio band, amateur radio and satellite, S-band (2 GHz to 4 GHz)	114.6 dB	122.4 dB
3.6 GHz	Radiolocation, aero communication and navigation, satellite, mobile, S-band	108.9 dB	113.5 dB
5.0 GHz	802.11a, 802.11n, aero communication and navigation, mobile communication, space and satellite operation, C-band (4 GHz to 8 GHz)	118.7 dB	123.3 dB

Output Filter

The PGA281 uses a chopper-stabilized architecture for excellent dc stability over temperature and life of operation. The device also removes 1/f frequency (flicker) noise, and therefore enables both high resolution and high repeatability for dc measurements. Although the chopper noise components are internally filtered, a minimal residual amount of high-frequency switching noise appears at the signal outputs. Placing an external, passive, low-pass filter after the output stage is recommended to remove this switching noise; Figure 42 shows two examples. This filter can also be used to isolate or decouple the charge switching pulses of an ADC input.

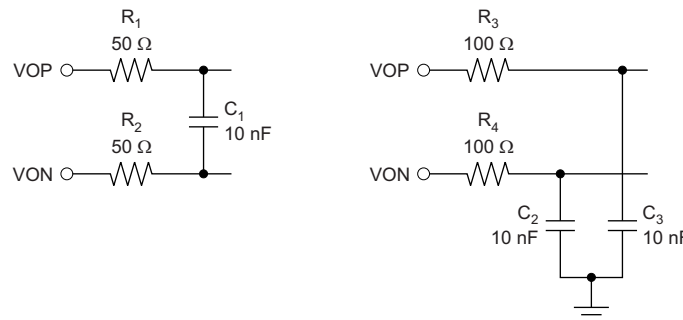

Figure 42. Typical Examples of Recommended Output Filters

Single-Ended Output

The output stage of the PGA281 is designed for highest precision. The fully-differential output avoids grounding errors and noise, and delivers twice the signal amplitude compared to single-ended signals. However, if desired, a single-ended output (VOP or VON) can be measured, referred to the voltage at the V_{OCM} pin. The output stage errors now relate to half the signal amplitude and half the signal gain. Figure 43 shows how the unused output is unconnected, but not disconnected from error detection. The usable voltage range for the V_{OCM} input is specified in the [Electrical Characteristics](#) and must be observed; that is, the output swing (of both outputs) should not saturate to the supply. Separate specifications for offset voltage and drift indicate higher offset voltage at lower gains because some error sources are not cancelled in the output stage connected in single-ended mode. Note that the gain is one-half of the gain set in reference to the gain table (see [Table 1](#)).

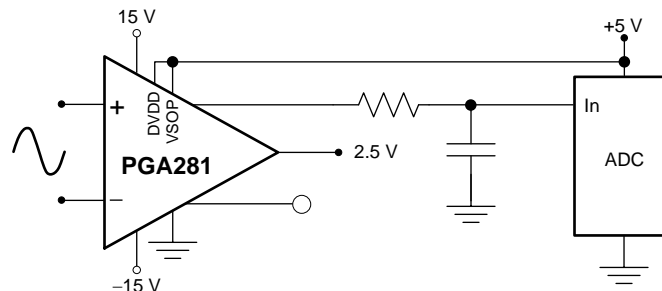

Figure 43. Single-Ended Connection Example

ERROR INDICATORS

Error Flag Detection

The PGA281 is designed for high dc precision and universal use, but it also allows monitoring of signal integrity. This error flag pin (EF, pin 2) alerts if an error is detected in one of the diagnostic areas specified in Figure 44. The error flag is a logic low during normal operation, but alarms to a logic high level when in an error state. The pin returns to normal operation (logic low) after the error state is removed. This added feature supports fully automated system setup and diagnostic capability while maintaining signal integrity. Figure 44 illustrates the diagnostic points available for error detection in the device architecture.

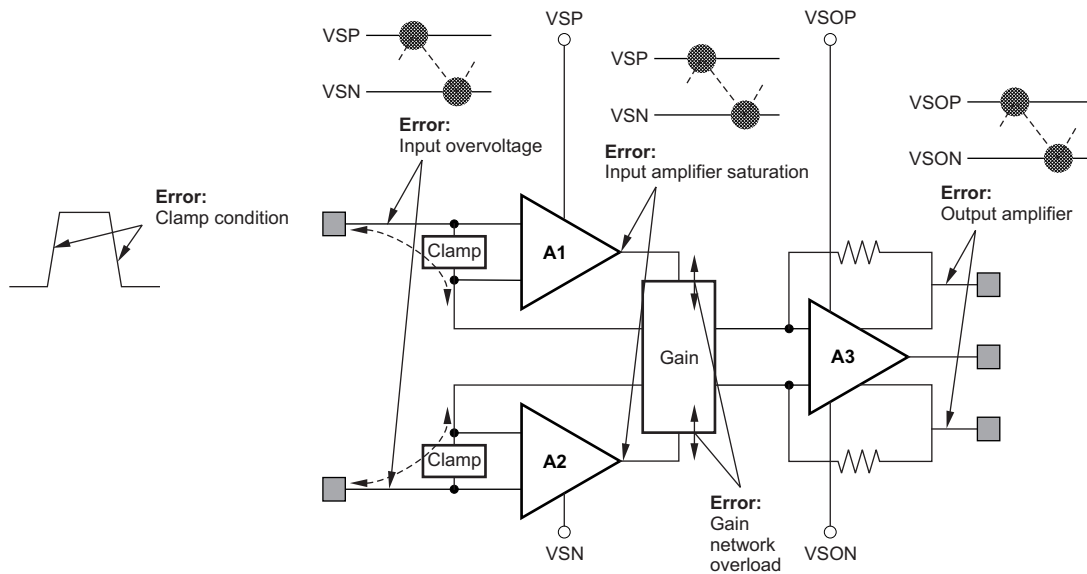

Figure 44. Diagnostic Points for Error Detection

Input Clamp Conduction

The input clamp protects the precision input amplifier from large voltages between the inputs caused by a fast signal slew rate in the input. This clamp circuit conducts current from the input pins during overload. Current flowing through the clamp can influence the signal source and cause long settling delays on passive input signal filters. The current is limited by internal resistors of approximately 600 Ω . Note that dynamic overload can result from the difference signal as well as the common-mode signal.

The input clamp turns on when the input signal slew rate is greater than ± 1 V/ μ s and faster than the amplifier slew rate (specified in the *Frequency Response* section of the [Electrical Characteristics](#)). Appropriate input filtering avoids input clamp activation.

Input Overvoltage

The input amplifier can only operate at high performance within a certain input voltage range inside the supply rail. The error flag (EF pin) alarm indicates a loss of performance as a result of the input voltage or the amplifier output approaching the rail.

Gain Network Overload

The gain setting network is protected against overcurrent conditions that occur because of an improper gain setting. The current into the resistors is proportional to the voltage between both inputs and the internal resistor; a low resistor value results in high gains. The error flag alarms if such an overload condition results from an improper gain setting.

Output Amplifier

The output stage is monitored for signal clipping to the supply rail and for overcurrent conditions.

POWER SUPPLY

The PGA281 requires three supply voltages: the high-voltage analog supply, the low-voltage output amplifier supply, and the digital I/O supply. This architecture allows an optimal interface (level-shift) to the different supply domains.

The high-voltage analog supplies, VSP and VSN, power the high-voltage input stage section. The substrate of the device is connected to VSN; therefore, it must be connected to the most negative potential.

The low-voltage analog output supplies, VSOP and VSON, operate within the high-voltage supply boundaries with two minimal limitations:

1. The usable range for VSON is from a minimum 5 V below VSP to as low as VSN. This 5 V provides the headroom for the output supply voltage of +2.7 V to +5 V. Even with less than a 5-V supply, this voltage difference is required for proper operation.
2. The common-mode control input, VOXM, requires a voltage at least 2 V less than VSP in order to support internal rail-to-rail performance.

These limitations are applicable when using a minimum supply or an extremely asymmetrical high-voltage supply. In most practical cases, VSON is connected to the ground of the system 3-V or 5-V supply.

VSOP can be turned on first or can be higher than VSP without harm, but operation fails if VSP and VSN are not present.

Observe the maximum voltage applied between VSOP and VSON because there is no internal protection.

Positive digital supply DVDD and digital ground VSON can also be set within the boundaries of VSP and VSN. However, DVDD must be 1 V less than VSP. DVDD can be turned on without the analog supply being present and is operational. Observe the maximum supply voltage because there is no internal protection. VSOP can be connected with DVDD if desired.

The negative digital supply is connected to the VSON pin. Take care if using split supplies on the VSOP and VSON pin because the logic low and high thresholds are determined by DVDD and VSON. In normal operation, VSON is connected to the system ground.

VSN is connected to the substrate; therefore, the voltage at VSON must not turn on the substrate diode to VSN. Use external Schottky diodes from VSON to VSN to prevent this condition.

The PGA281 uses an internal chopper-stabilized architecture, and requires good supply decoupling. RC decoupling using series resistors in the supply is recommended. Series resistors can be in the range of 15 Ω to 22 Ω . RC decoupling also prevents a very fast rise time of the supply voltage, thus avoiding parasitic currents in the device. Connecting supply wires into an already turned-on supply (very fast rise time) without such a filter can damage the device as a result of voltage overshoot and parasitic charge currents. Figure 45 shows an example of a supply connection using RC bypass filters. DVDD may not need decoupling, but if the digital supply is noisy, a filter is recommended.

NOTE

Rise and fall times for the high-voltage supplies must be slower than 1 V/ μ s.

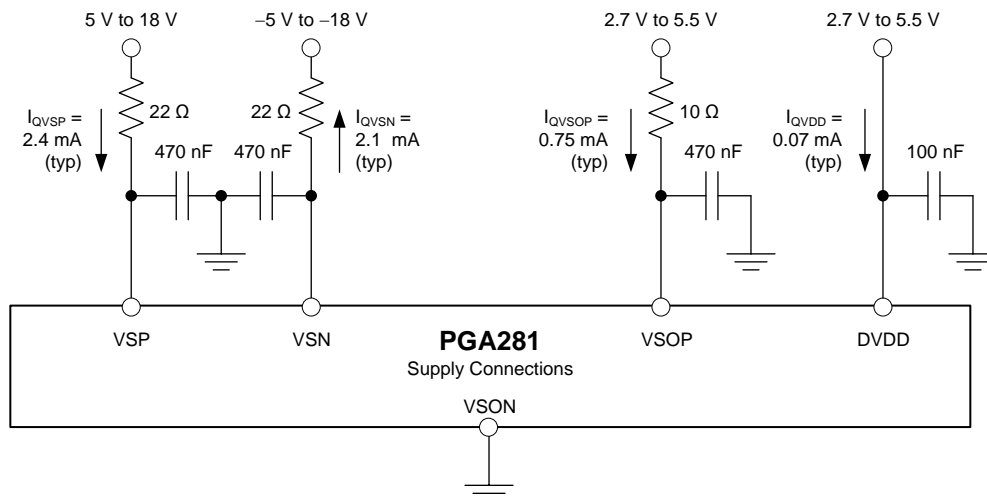

NOTE: The supply voltages shown are only example values.

Figure 45. Supply Connection Example Using RC Bypass Filters for Good Decoupling

Quiescent Current

The PGA281 uses internal resistor networks and switches to set the signal gain. Consequently, the current through the resistor network may vary with the gain and signal amplitude. Under normal operation, the gain-related current is low (less than 400 μ A). However, in signal overload conditions while a high gain is selected, this amount of current may increase.

Settling Time

The PGA281 provides very low drift and low noise, and therefore allows repeatable settling to a precise value. Signal-related load and power-dissipation variables have minimal effect on device accuracy.

Overload Recovery

Overload conditions can vary widely and there are multiple points in an instrumentation amplifier that can be overloaded. During input overload, the PGA281 folds the output signal partially back as a result of the differential signal structure and summing, but the error flag indicates such fault conditions. The amplifier recovers safely after removing the overload condition, as long as it is within the specified operating range as shown in [Figure 46](#).

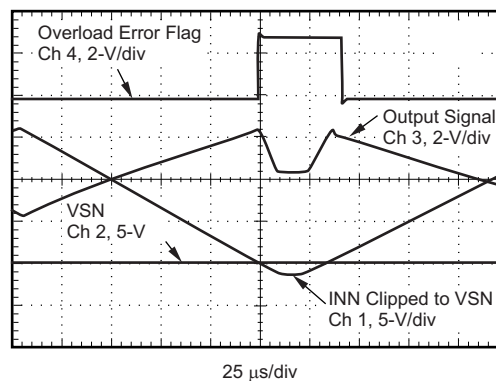

Figure 46. Input Clipping: Negative Side

Avoid dynamic overload by using adequate signal filtering that reduces the input slew rate to the slew rate of the amplifier.

Input Bias Current Return Path

The input impedance of the PGA281 is extremely high; greater than 1 GΩ. However, make sure to provide a path for the input bias current of both inputs. This input bias current is typically 300 pA. A high input impedance means that this input bias current changes very little with varying input voltage.

Input circuitry must provide a path for this input bias current for proper operation. Figure 47 shows various provisions for an input bias current path. Without a bias current path, the inputs float to a potential that exceeds the common-mode range of the PGA281, and the input amplifiers saturate. If the differential source resistance is low, connect the bias current return path to one input (as shown in the thermocouple example in Figure 47). With higher source impedance, using two equal resistors provides a balanced input with the possible advantage of lower input offset voltage as a result of bias current and better high-frequency common-mode rejection.

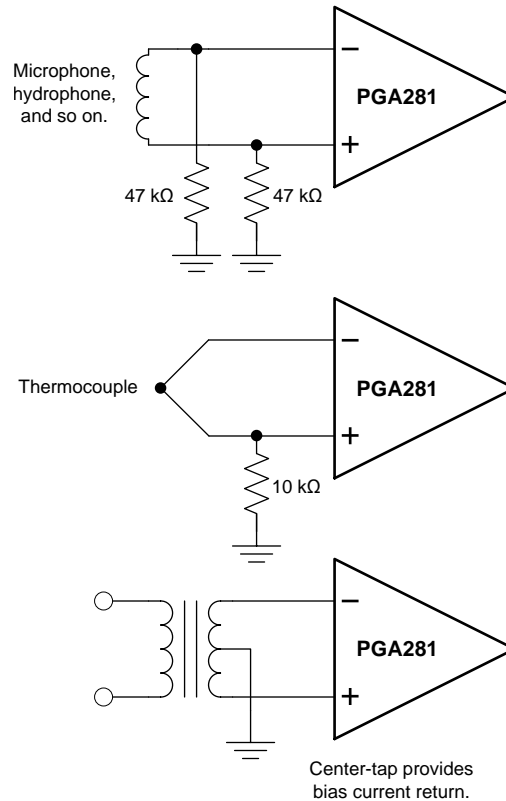

Figure 47. Providing an Input Common-Mode Current Path

Application Examples

Multiplexed Data Acquisition

Figure 48 shows the PGA281 used in a multiplexed data-acquisition application.

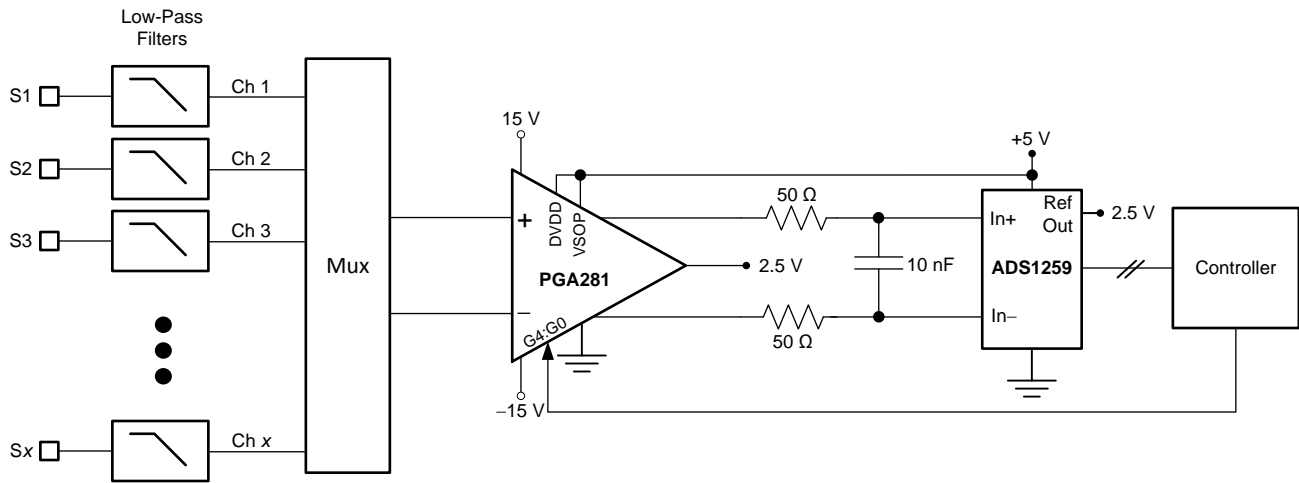

Figure 48. Typical Block Diagram for Multiplexed Data Acquisition

Programmable Logic Controller (PLC) Input

An example of the PGA281 used in a programmable logic controller (PLC) input application is shown in Figure 49 .

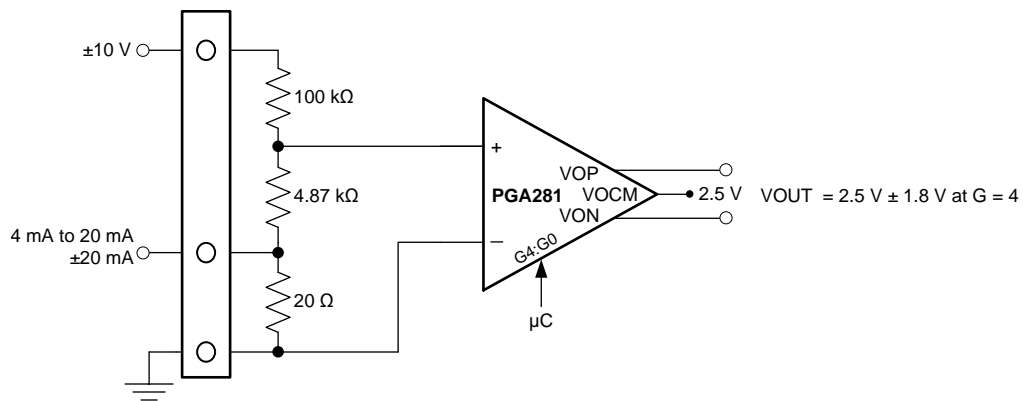

Figure 49. ±10-V, 4-mA to 20-mA PLC Input

SAR ADC Driver

An example of the PGA281 used as a SAR ADC driver with the [THS4031](#) used as input buffers to maximize SNR and THD is shown in [Figure 50](#).

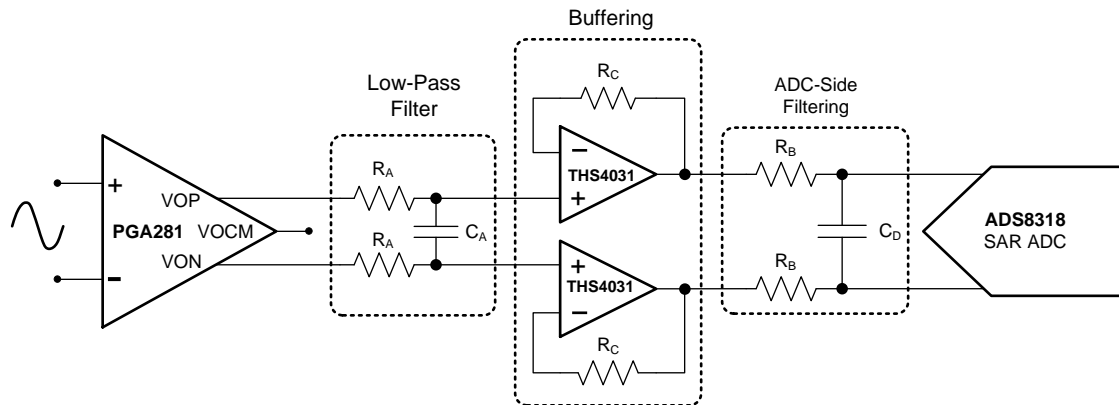

Figure 50. SAR Driver with Input Buffer

Using TINA-TI™ SPICE-Based Analog Simulation Program with the PGA281

TINA is a simple, powerful, and easy-to-use circuit simulation program based on a SPICE engine. TINA-TI is a free, fully functional version of the TINA software, preloaded with a library of macromodels in addition to a range of both passive and active models. It provides all the conventional dc, transient, and frequency-domain analysis of SPICE, as well as additional design capabilities.

Available as a [free download from the Analog eLab Design Center](#), TINA-TI offers extensive post-processing capability that allows users to format results in a variety of ways.

Virtual instruments offer users the ability to select input waveforms and probe circuit nodes, voltages, and waveforms, creating a dynamic quick-start tool.

NOTE

NOTE: These files require that either the TINA software (from DesignSoft) or TINA-TI software be installed. Download the free TINA-TI software from the [TINA-TI folder](#).

Two-Terminal Programmable Logic Controller

The circuit in [Figure 51](#) is used to convert inputs of ± 10 V, ± 5 V, or ± 20 mA to an output voltage range from 0 V to 5 V. The input selection depends on the settings of the switch and the PGA281 gain. Further explanation, as well as the TINA-TI simulation circuit, is provided in the compressed file that can be downloaded at the following link: [PGA281 PLC Circuit](#).

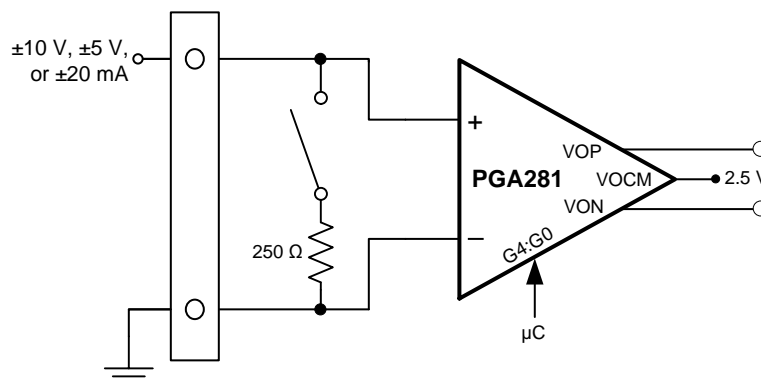

Figure 51. Two-Terminal, Programmable Logic Controller (PLC) Input

RTD Amplifier

An example of the PGA281 used in an RTD-amplification application is shown in [Figure 52](#). Click the following link to download the TINA-TI file: [PGA281 RTD](#).

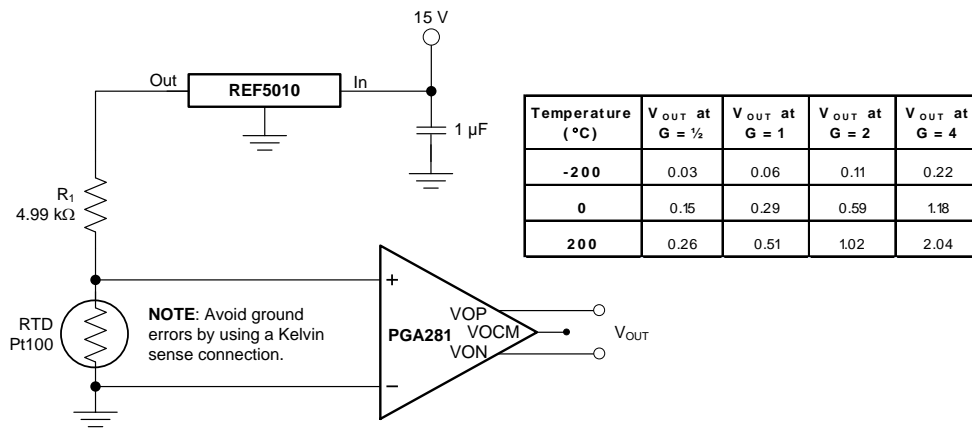

Figure 52. RTD Amplifier

High-Side Current Sensing

[Figure 53](#) shows an example of how the PGA281 can be used for high-side current sensing. The load current (I_{LOAD}) creates a voltage drop across the shunt resistor (R_{SHUNT}). This voltage can be amplified or attenuated by the PGA281. The wide gain options and excellent common-mode rejection of the PGA281 make it ideal for this type of application. Click the following link to download the TINA-TI file: [PGA281 Current Sense](#).

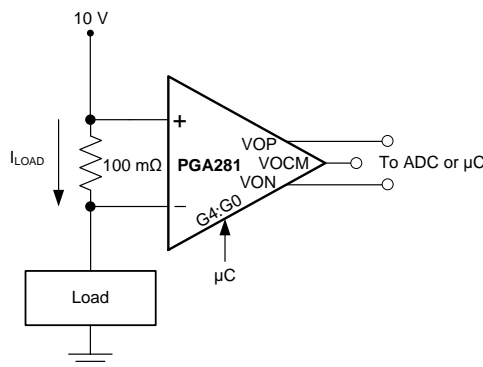

Figure 53. High-Side Current Sensing

Bridge Amplifier

An example of the PGA281 used in a bridge or strain gauge amplification application is shown in [Figure 54](#). Click the following link to download the TINA-TI file: [PGA281 Bridge Amplifier](#).

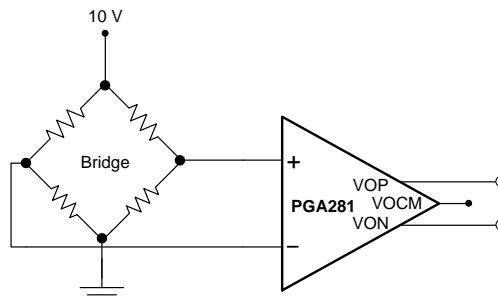

Figure 54. Programmable Bridge Amplifier

Evaluation Module

The PGA281EVM provides basic functional evaluation of the PGA281. A picture of the PGA281EVM is provided in [Figure 55](#).

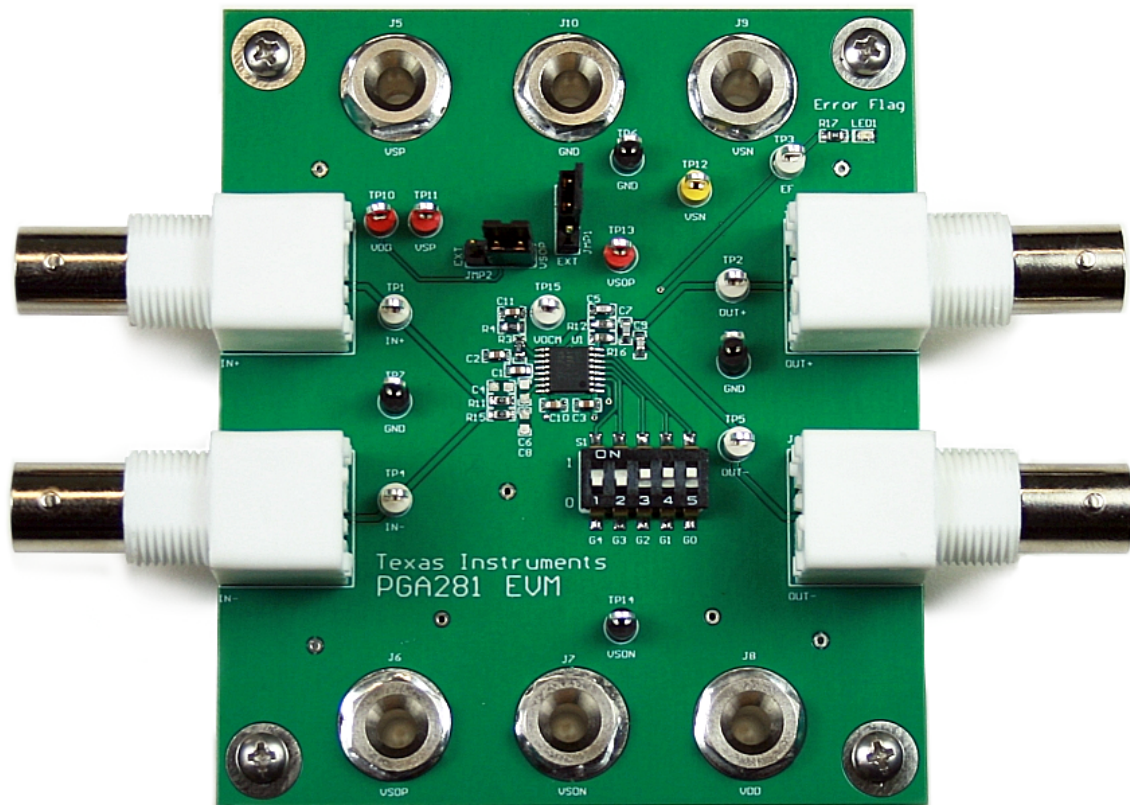



Figure 55. PGA281 Evaluation Module

The PGA281 evaluation module provides the following features:

- Easy access to nodes with surface-mount test points
- Convenient input and output filtering
- Simple gain setting and error flag indication

The [PGA281EVM User Guide \(SBOU130\)](#), available for download at www.ti.com provides instructions on how to set up the device for evaluation. The user guide also includes schematics, layout, and a bill of materials (BOM).

PACKAGING INFORMATION

Orderable Device	Status (1)	Package Type	Package Drawing	Pins	Package Qty	Eco Plan (2)	Lead finish/ Ball material (6)	MSL Peak Temp (3)	Op Temp (°C)	Device Marking (4/5)	Samples
PGA281AIPW	ACTIVE	TSSOP	PW	16	90	RoHS & Green	NIPDAU	Level-2-260C-1 YEAR	-40 to 125	PGA 281	
PGA281AIPWR	ACTIVE	TSSOP	PW	16	2000	RoHS & Green	NIPDAU	Level-2-260C-1 YEAR	-40 to 125	PGA 281	

(1) The marketing status values are defined as follows:

ACTIVE: Product device recommended for new designs.

LIFEBUY: TI has announced that the device will be discontinued, and a lifetime-buy period is in effect.

NRND: Not recommended for new designs. Device is in production to support existing customers, but TI does not recommend using this part in a new design.

PREVIEW: Device has been announced but is not in production. Samples may or may not be available.

OBSOLETE: TI has discontinued the production of the device.

(2) **RoHS:** TI defines "RoHS" to mean semiconductor products that are compliant with the current EU RoHS requirements for all 10 RoHS substances, including the requirement that RoHS substance do not exceed 0.1% by weight in homogeneous materials. Where designed to be soldered at high temperatures, "RoHS" products are suitable for use in specified lead-free processes. TI may reference these types of products as "Pb-Free".

RoHS Exempt: TI defines "RoHS Exempt" to mean products that contain lead but are compliant with EU RoHS pursuant to a specific EU RoHS exemption.

Green: TI defines "Green" to mean the content of Chlorine (Cl) and Bromine (Br) based flame retardants meet JS709B low halogen requirements of <=1000ppm threshold. Antimony trioxide based flame retardants must also meet the <=1000ppm threshold requirement.

(3) MSL, Peak Temp. - The Moisture Sensitivity Level rating according to the JEDEC industry standard classifications, and peak solder temperature.

(4) There may be additional marking, which relates to the logo, the lot trace code information, or the environmental category on the device.

(5) Multiple Device Markings will be inside parentheses. Only one Device Marking contained in parentheses and separated by a "~" will appear on a device. If a line is indented then it is a continuation of the previous line and the two combined represent the entire Device Marking for that device.

(6) Lead finish/Ball material - Orderable Devices may have multiple material finish options. Finish options are separated by a vertical ruled line. Lead finish/Ball material values may wrap to two lines if the finish value exceeds the maximum column width.

Important Information and Disclaimer: The information provided on this page represents TI's knowledge and belief as of the date that it is provided. TI bases its knowledge and belief on information provided by third parties, and makes no representation or warranty as to the accuracy of such information. Efforts are underway to better integrate information from third parties. TI has taken and continues to take reasonable steps to provide representative and accurate information but may not have conducted destructive testing or chemical analysis on incoming materials and chemicals. TI and TI suppliers consider certain information to be proprietary, and thus CAS numbers and other limited information may not be available for release.

In no event shall TI's liability arising out of such information exceed the total purchase price of the TI part(s) at issue in this document sold by TI to Customer on an annual basis.

TAPE AND REEL INFORMATION

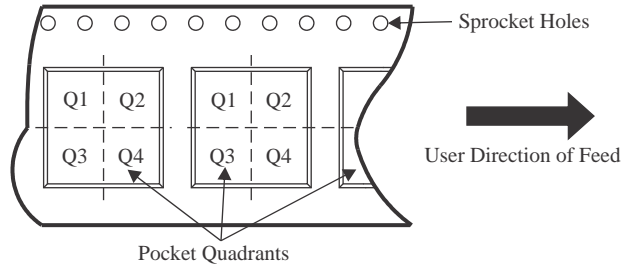
QUADRANT ASSIGNMENTS FOR PIN 1 ORIENTATION IN TAPE

*All dimensions are nominal

Device	Package Type	Package Drawing	Pins	SPQ	Reel Diameter (mm)	Reel Width W1 (mm)	A0 (mm)	B0 (mm)	K0 (mm)	P1 (mm)	W (mm)	Pin1 Quadrant
PGA281AIPWR	TSSOP	PW	16	2000	330.0	12.4	6.9	5.6	1.6	8.0	12.0	Q1

TAPE AND REEL BOX DIMENSIONS

*All dimensions are nominal

Device	Package Type	Package Drawing	Pins	SPQ	Length (mm)	Width (mm)	Height (mm)
PGA281AIPWR	TSSOP	PW	16	2000	356.0	356.0	35.0

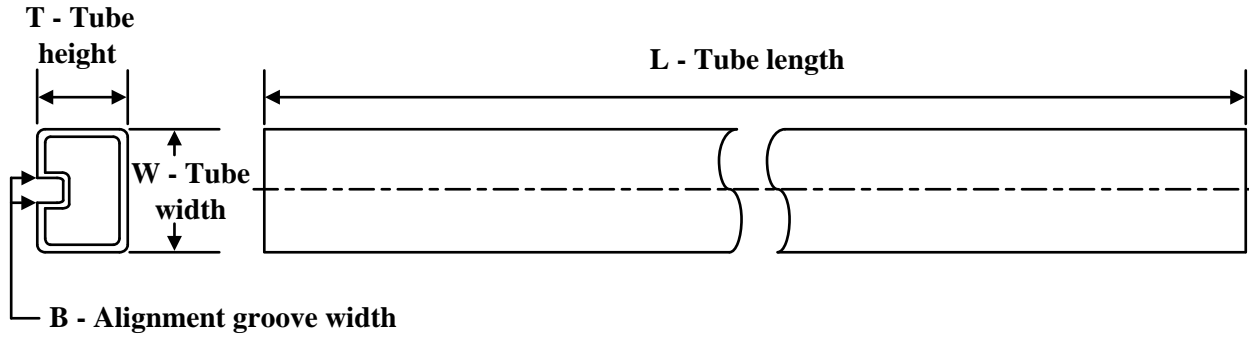
TUBE

*All dimensions are nominal

Device	Package Name	Package Type	Pins	SPQ	L (mm)	W (mm)	T (μm)	B (mm)
PGA281AIPW	PW	TSSOP	16	90	530	10.2	3600	3.5



4220204/A 02/2017

NOTES:

1. All linear dimensions are in millimeters. Any dimensions in parenthesis are for reference only. Dimensioning and tolerancing per ASME Y14.5M.
2. This drawing is subject to change without notice.
3. This dimension does not include mold flash, protrusions, or gate burrs. Mold flash, protrusions, or gate burrs shall not exceed 0.15 mm per side.
4. This dimension does not include interlead flash. Interlead flash shall not exceed 0.25 mm per side.
5. Reference JEDEC registration MO-153.

EXAMPLE BOARD LAYOUT

PW0016A

TSSOP - 1.2 mm max height

SMALL OUTLINE PACKAGE



LAND PATTERN EXAMPLE
EXPOSED METAL SHOWN
SCALE: 10X



SOLDER MASK DETAILS

4220204/A 02/2017

NOTES: (continued)

- 6. Publication IPC-7351 may have alternate designs.
- 7. Solder mask tolerances between and around signal pads can vary based on board fabrication site.

EXAMPLE STENCIL DESIGN

PW0016A

TSSOP - 1.2 mm max height

SMALL OUTLINE PACKAGE

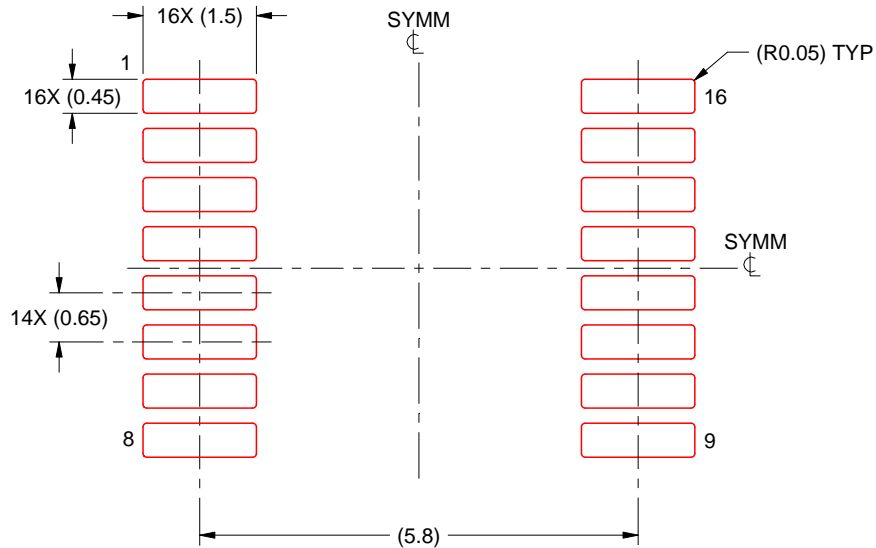

SOLDER PASTE EXAMPLE
BASED ON 0.125 mm THICK STENCIL
SCALE: 10X

4220204/A 02/2017

NOTES: (continued)

8. Laser cutting apertures with trapezoidal walls and rounded corners may offer better paste release. IPC-7525 may have alternate design recommendations.
9. Board assembly site may have different recommendations for stencil design.

IMPORTANT NOTICE AND DISCLAIMER

TI PROVIDES TECHNICAL AND RELIABILITY DATA (INCLUDING DATA SHEETS), DESIGN RESOURCES (INCLUDING REFERENCE DESIGNS), APPLICATION OR OTHER DESIGN ADVICE, WEB TOOLS, SAFETY INFORMATION, AND OTHER RESOURCES "AS IS" AND WITH ALL FAULTS, AND DISCLAIMS ALL WARRANTIES, EXPRESS AND IMPLIED, INCLUDING WITHOUT LIMITATION ANY IMPLIED WARRANTIES OF MERCHANTABILITY, FITNESS FOR A PARTICULAR PURPOSE OR NON-INFRINGEMENT OF THIRD PARTY INTELLECTUAL PROPERTY RIGHTS.

These resources are intended for skilled developers designing with TI products. You are solely responsible for (1) selecting the appropriate TI products for your application, (2) designing, validating and testing your application, and (3) ensuring your application meets applicable standards, and any other safety, security, regulatory or other requirements.

These resources are subject to change without notice. TI grants you permission to use these resources only for development of an application that uses the TI products described in the resource. Other reproduction and display of these resources is prohibited. No license is granted to any other TI intellectual property right or to any third party intellectual property right. TI disclaims responsibility for, and you will fully indemnify TI and its representatives against, any claims, damages, costs, losses, and liabilities arising out of your use of these resources.

TI's products are provided subject to [TI's Terms of Sale](#) or other applicable terms available either on [ti.com](https://www.ti.com) or provided in conjunction with such TI products. TI's provision of these resources does not expand or otherwise alter TI's applicable warranties or warranty disclaimers for TI products.

TI objects to and rejects any additional or different terms you may have proposed.

Mailing Address: Texas Instruments, Post Office Box 655303, Dallas, Texas 75265
Copyright © 2023, Texas Instruments Incorporated

Looking for pricing, stock, or lifecycle information?

Click below to explore more details on WIN SOURCE:

 [View PGA281AIPWR](#) on WIN SOURCE

 [Texas Instruments](#) Information

Optimize Your Supply Chain with WIN SOURCE Solutions

-  Global Sourcing Solution
-  Obsolete Management
-  Cost Control Management
-  Shortage Management
-  Alternative Solution
-  Excess Inventory Management